

GROUP 6 TROUBLESHOOTING

1. WHEN STARTING SWITCH IS TURNED ON, CLUSTER LAMP DOES NOT LIGHT UP

- Before carrying out below procedure, check all the related connectors are properly inserted and the fuse No.2 is not blown out and ON/OFF of bulb.
- After checking, connect the disconnected connectors again immediately unless otherwise specified.

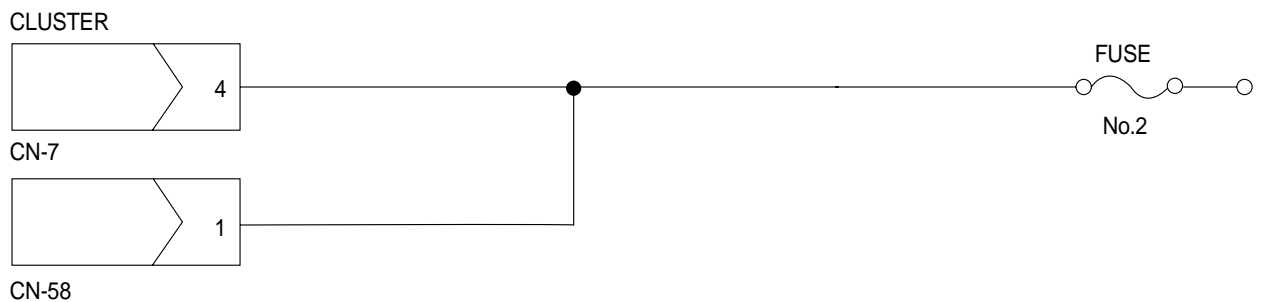
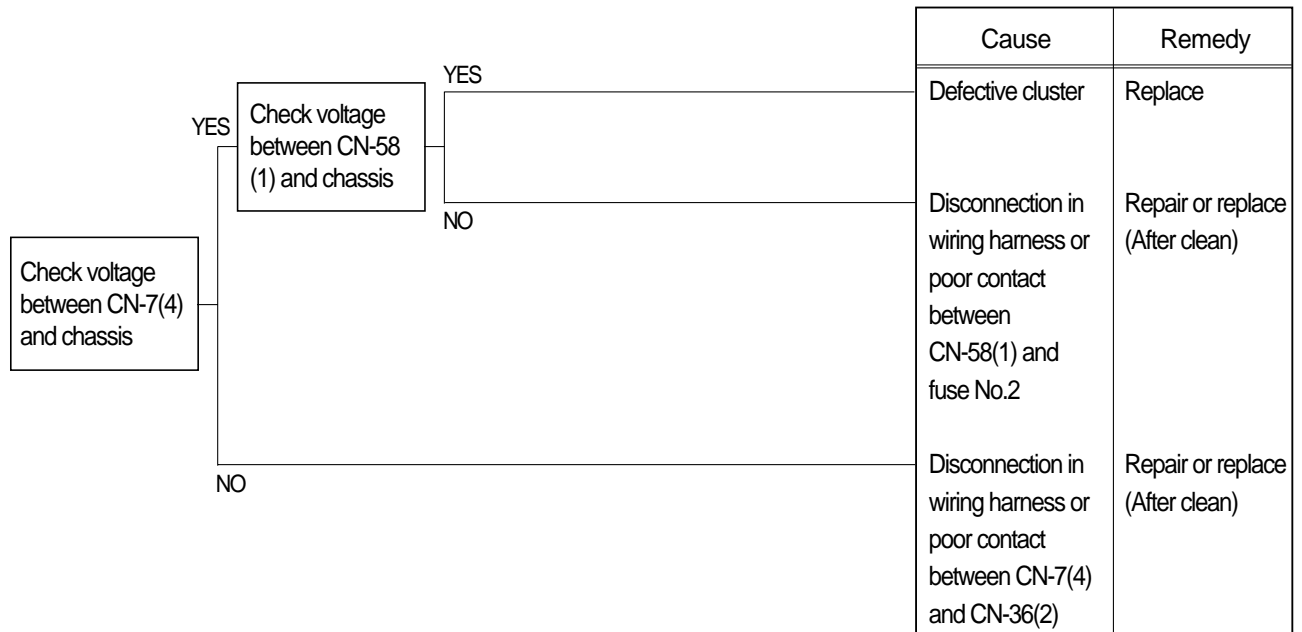

Check voltage

YES	20 ~ 30V
NO	0V

2. WHEN COOLANT OVERHEAT LAMP LIGHTS UP (Engine is started)

- Before carrying out below procedure, check all the related connectors are properly inserted.
- After checking, connect the disconnected connectors again immediately unless otherwise specified.

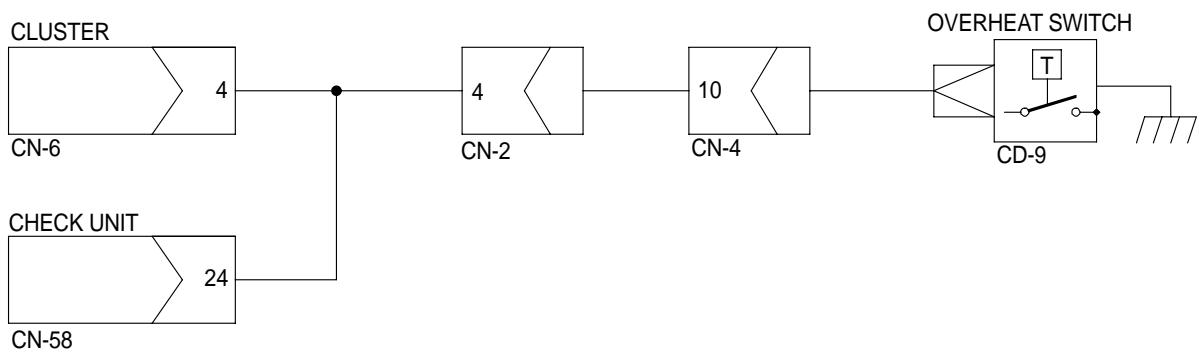
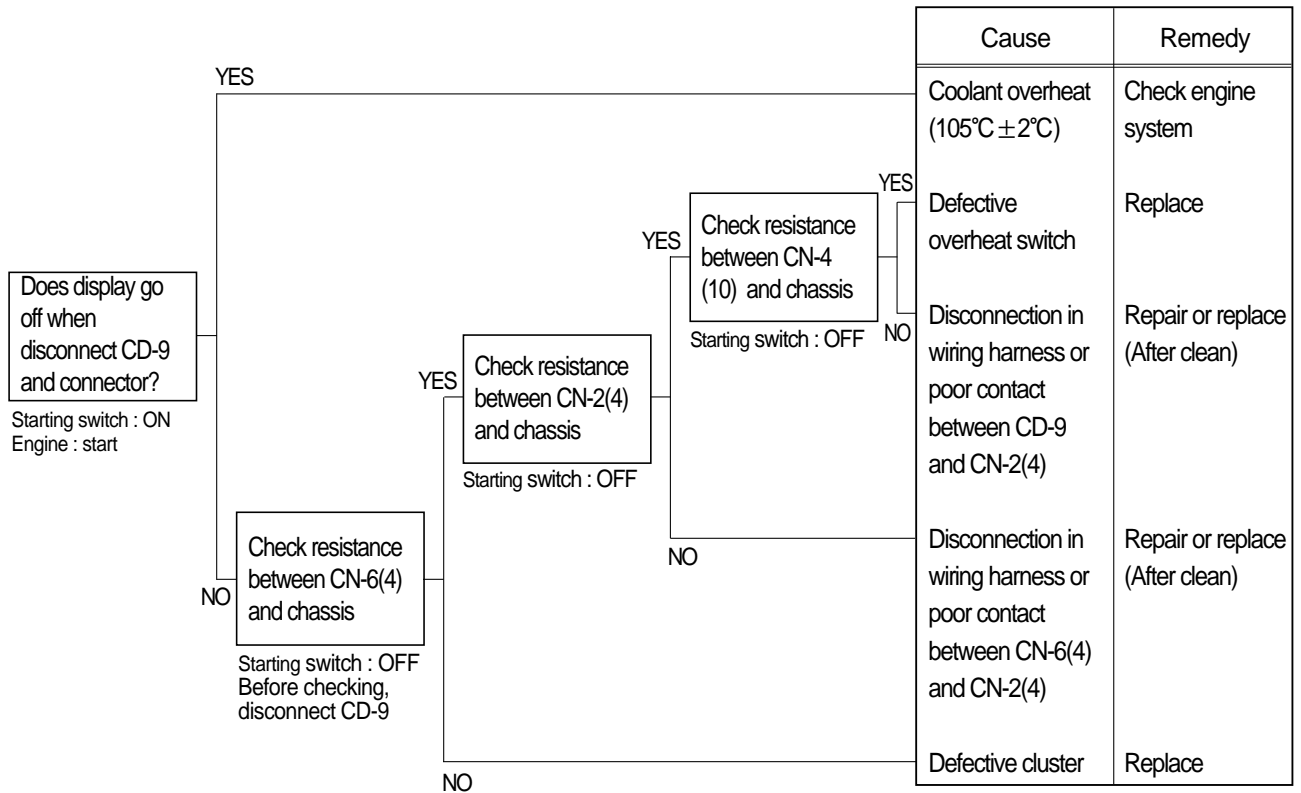

Check resistance

YES	MAX 1 Ω
NO	MIN 1M Ω

3. WHEN AIR CLEANER LAMP LIGHTS UP(Engine is started)

- Before carrying out below procedure, check all the related connectors are properly inserted.
- After checking, connect the disconnected connectors again immediately unless otherwise specified.

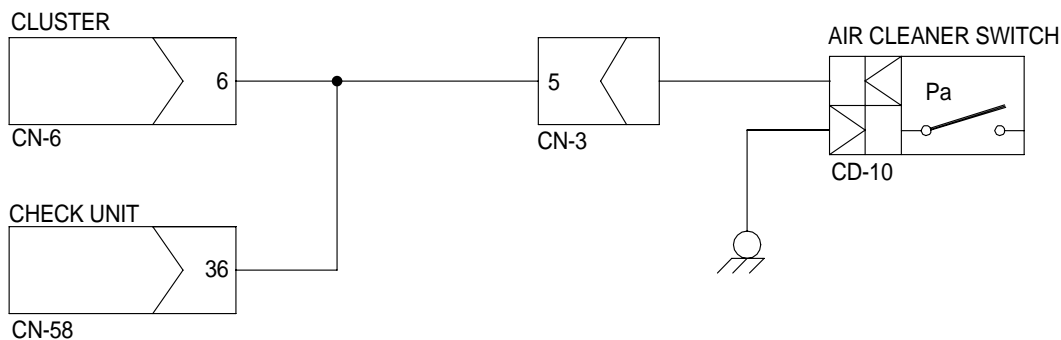
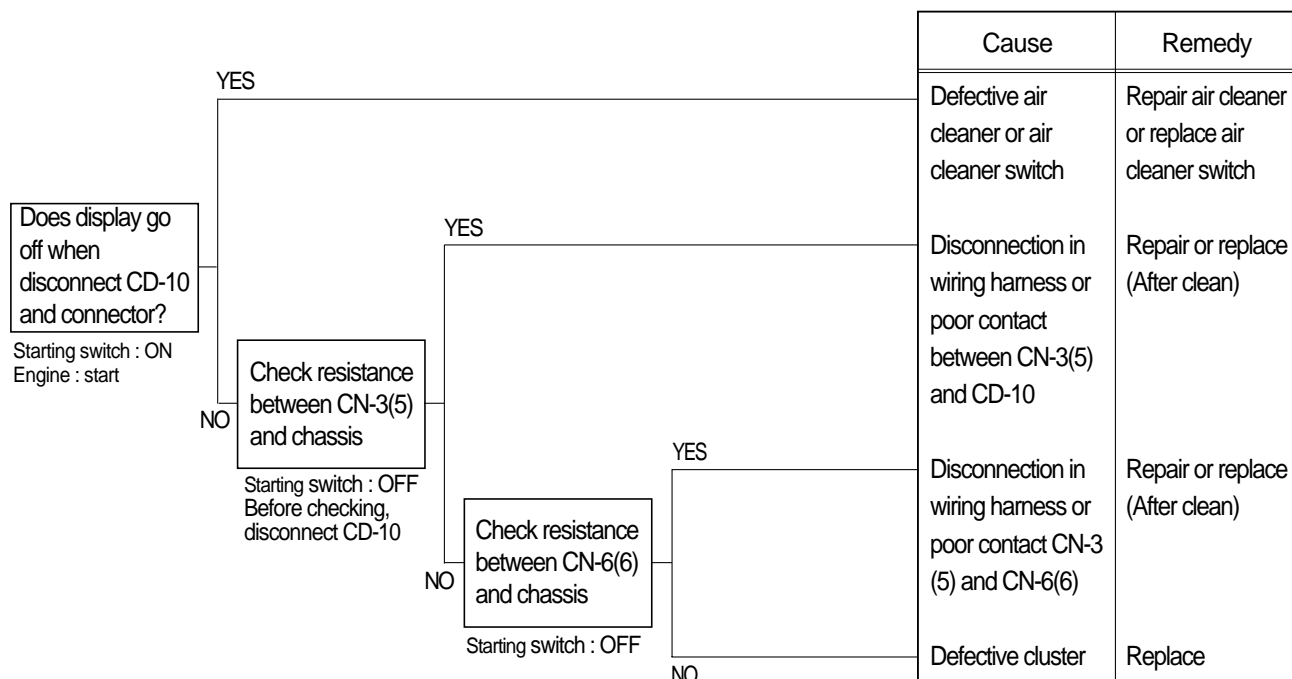

Check resistance

YES	MAX 1 Ω
NO	MIN 1M Ω

4. WHEN ENGINE OIL PRESSURE LAMP LIGHTS UP(Engine is started)

- Before carrying out below procedure, check all the related connectors are properly inserted.
- After checking, connect the disconnected connectors again immediately unless otherwise specified.

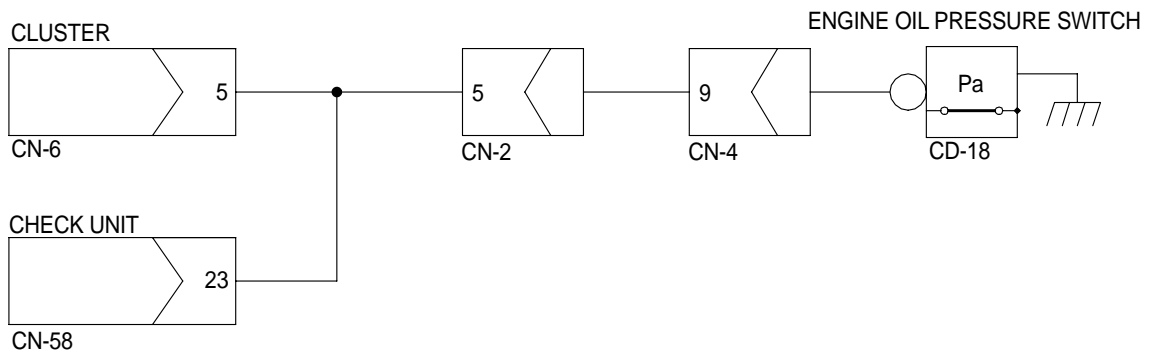
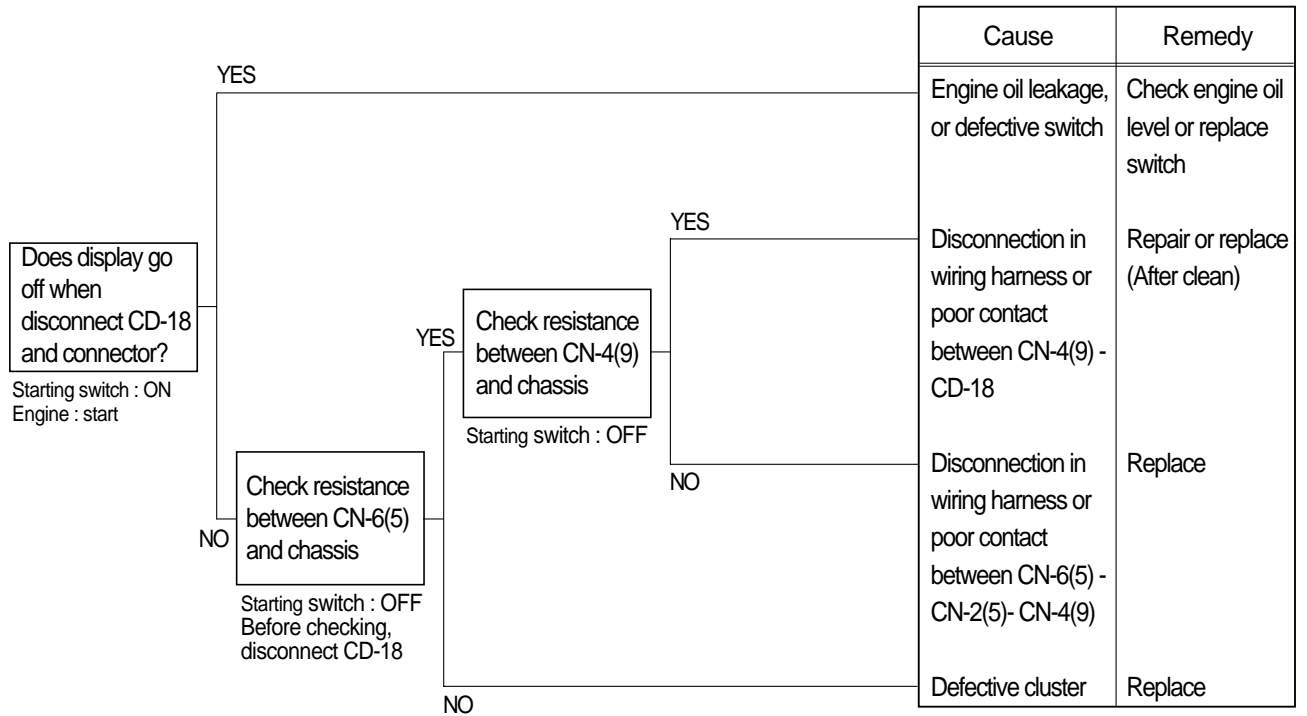

Check resistance

YES	MAX 1 Ω
NO	MIN 1M Ω

5.  **WHEN HYDRAULIC OIL TEMPERATURE LAMP LIGHTS UP**(Engine is started)

- Before carrying out below procedure, check all the related connectors are properly inserted.
- After checking, connect the disconnected connectors again immediately unless otherwise specified.

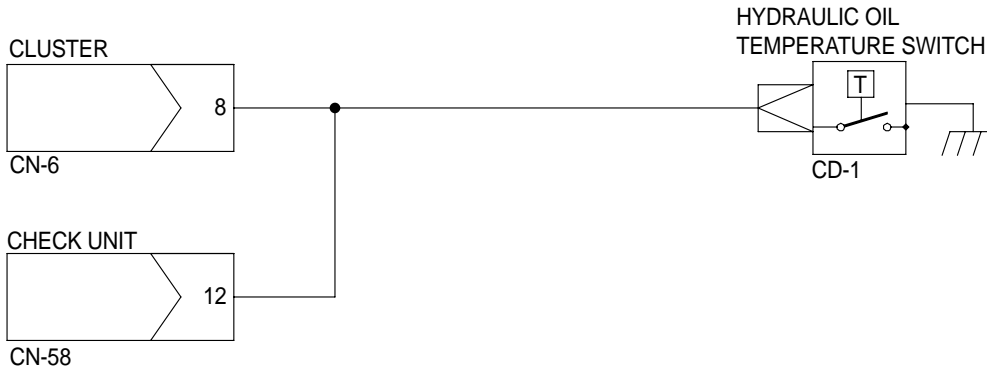
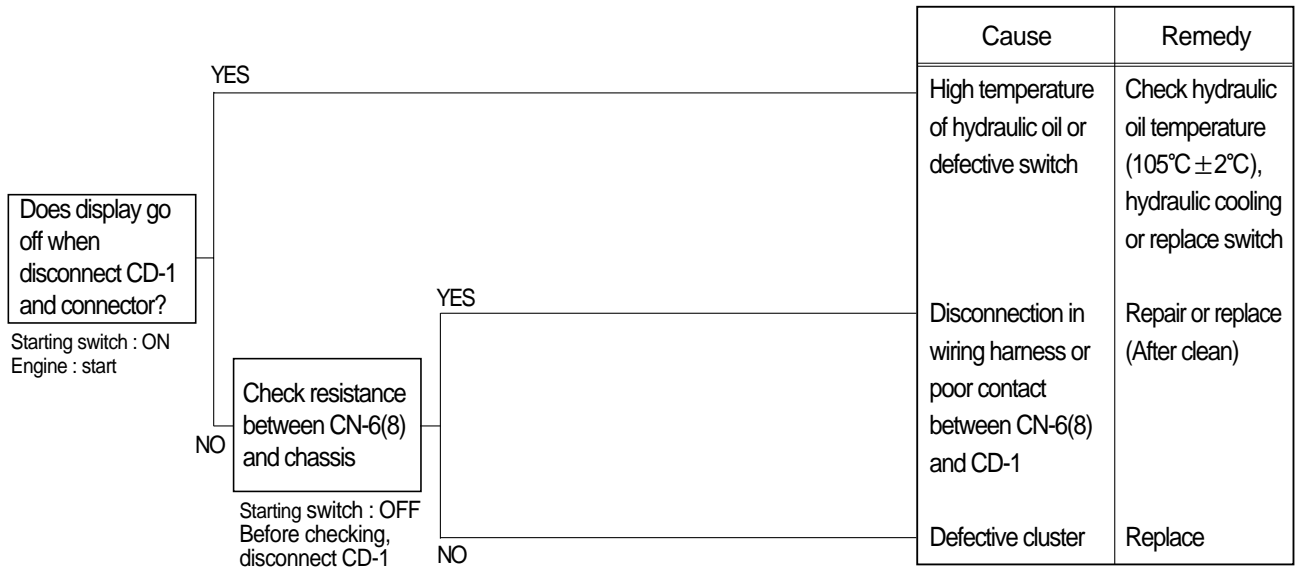

Check resistance

YES	MAX 1 Ω
NO	MIN 1M Ω

6. WHEN TORQUE CONVERTER OIL TEMPERATURE GAUGE DOES NOT OPERATE

(Check torque converter oil temperature lamp ON/OFF)

- Before carrying out below procedure, check all the related connectors are properly inserted.
- After checking, connect the disconnected connectors again immediately unless otherwise specified.

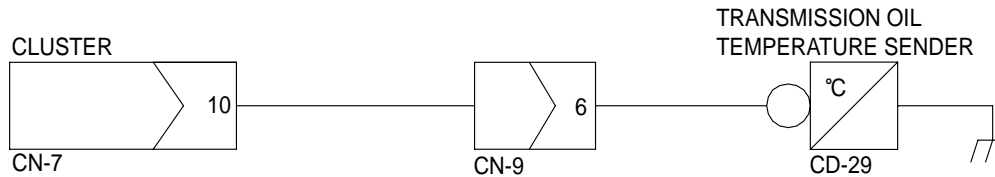
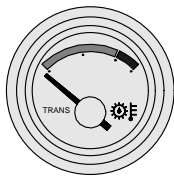
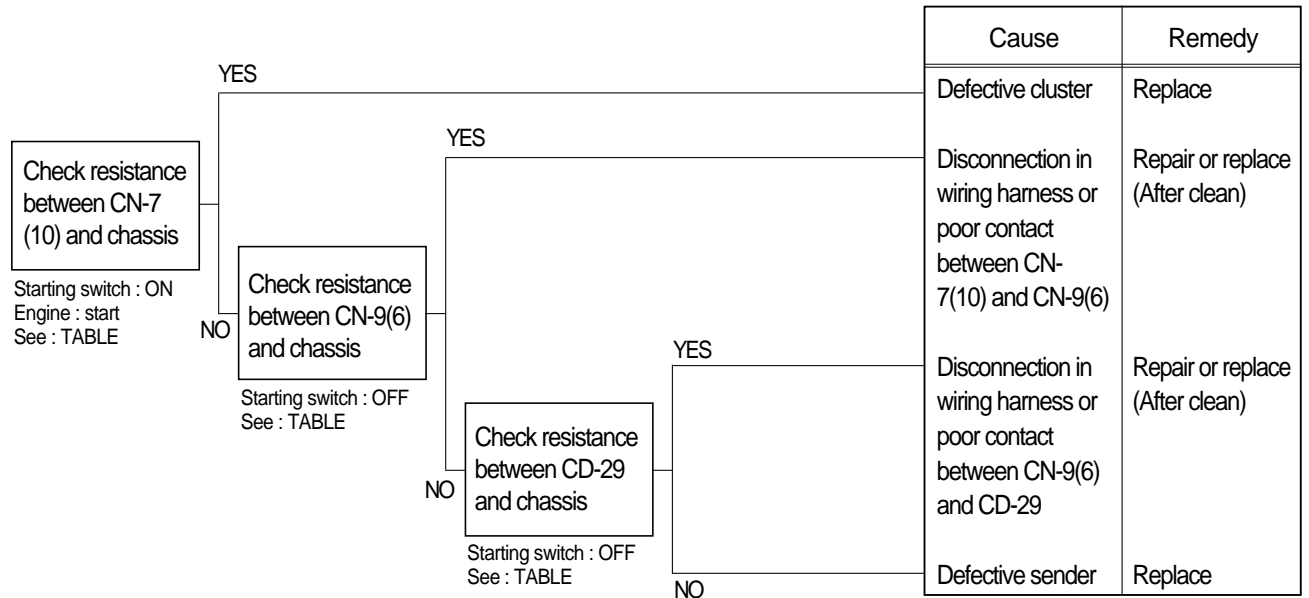

Check resistance

YES	MAX 1 Ω
NO	MIN 1M Ω

Check table

Temperature Item	50°C	92°C	120°C	130°C
Unit resistance(Ω)	168.7	(34)	19.5	12.4
Tolerance	0° ~ -10°	(-)	±3°	+10° ~ 0°
Angle	-30°	-8°	+27°	+30°

7. WHEN COOLANT TEMPERATURE GAUGE DOES NOT OPERATE

(Check coolant temperature lamp ON/OFF)

- Before carrying out below procedure, check all the related connectors are properly inserted.
- After checking, connect the disconnected connectors again immediately unless otherwise specified.

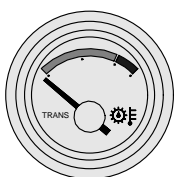
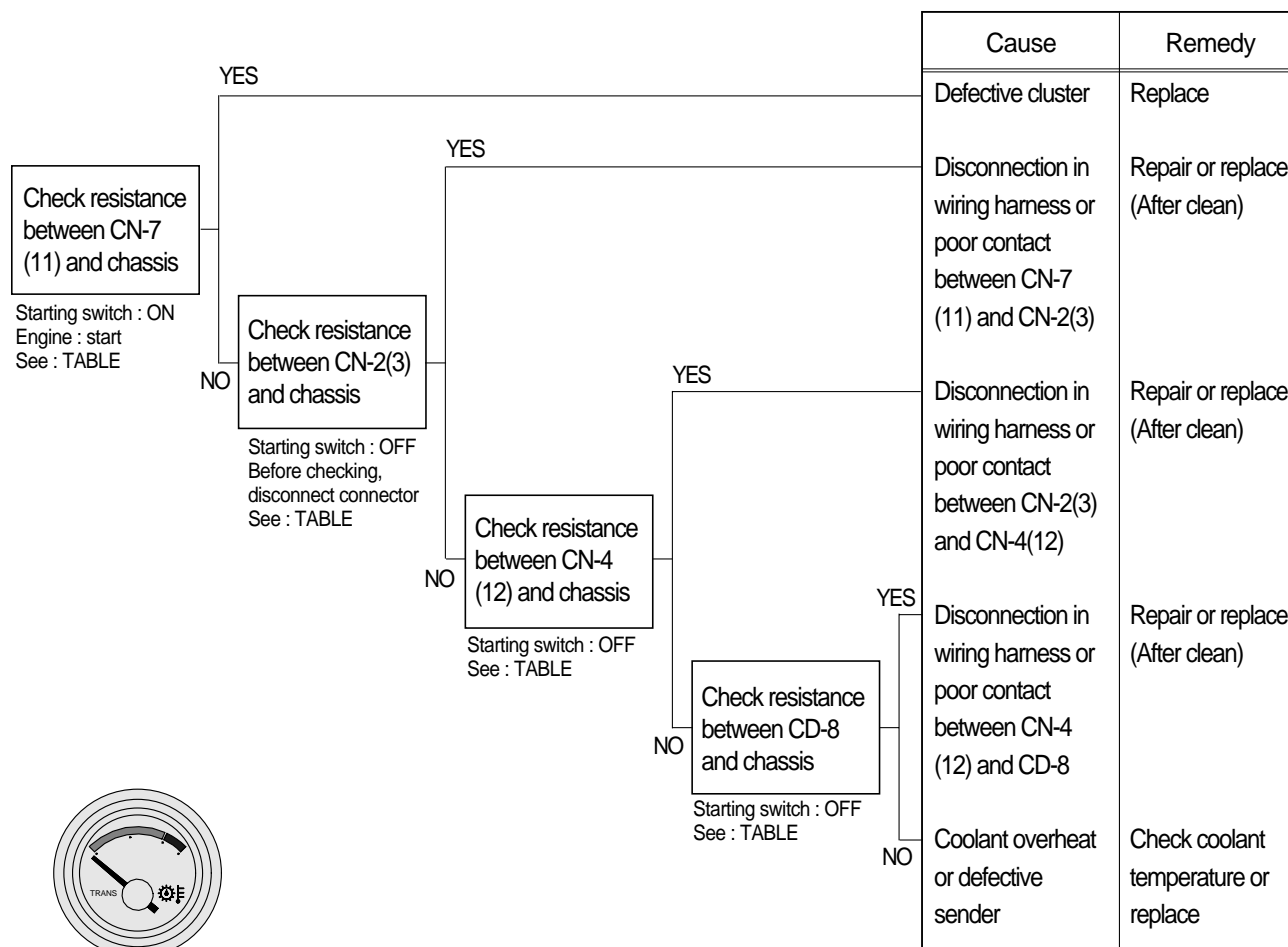

CLUSTER

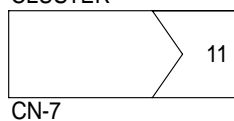

CN-7

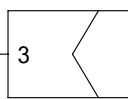

CN-2

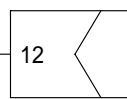

CN-4

WATER TEMPERATURE SENDER

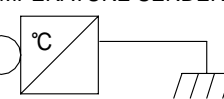

CD-8

Check resistance

YES	MAX 1 Ω
NO	MIN 1M Ω

Check table

Temperature Item	(40°C)	91°C	105°C	120°C
Unit resistance(Ω)	222	(41.3)	28	19.2
Tolerance	$\pm 5^\circ$	(-)	± 4.5	(-)
Angle	-30°	0°	+13°	+30°

8. WHEN FUEL GAUGE DOES NOT OPERATE (Check warning lamp ON/OFF)

- Before carrying out below procedure, check all the related connectors are properly inserted.
- After checking, connect the disconnected connectors again immediately unless otherwise specified.

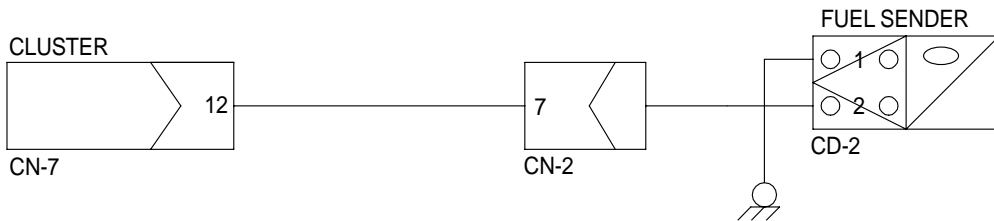
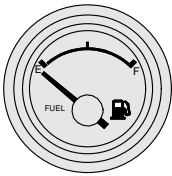
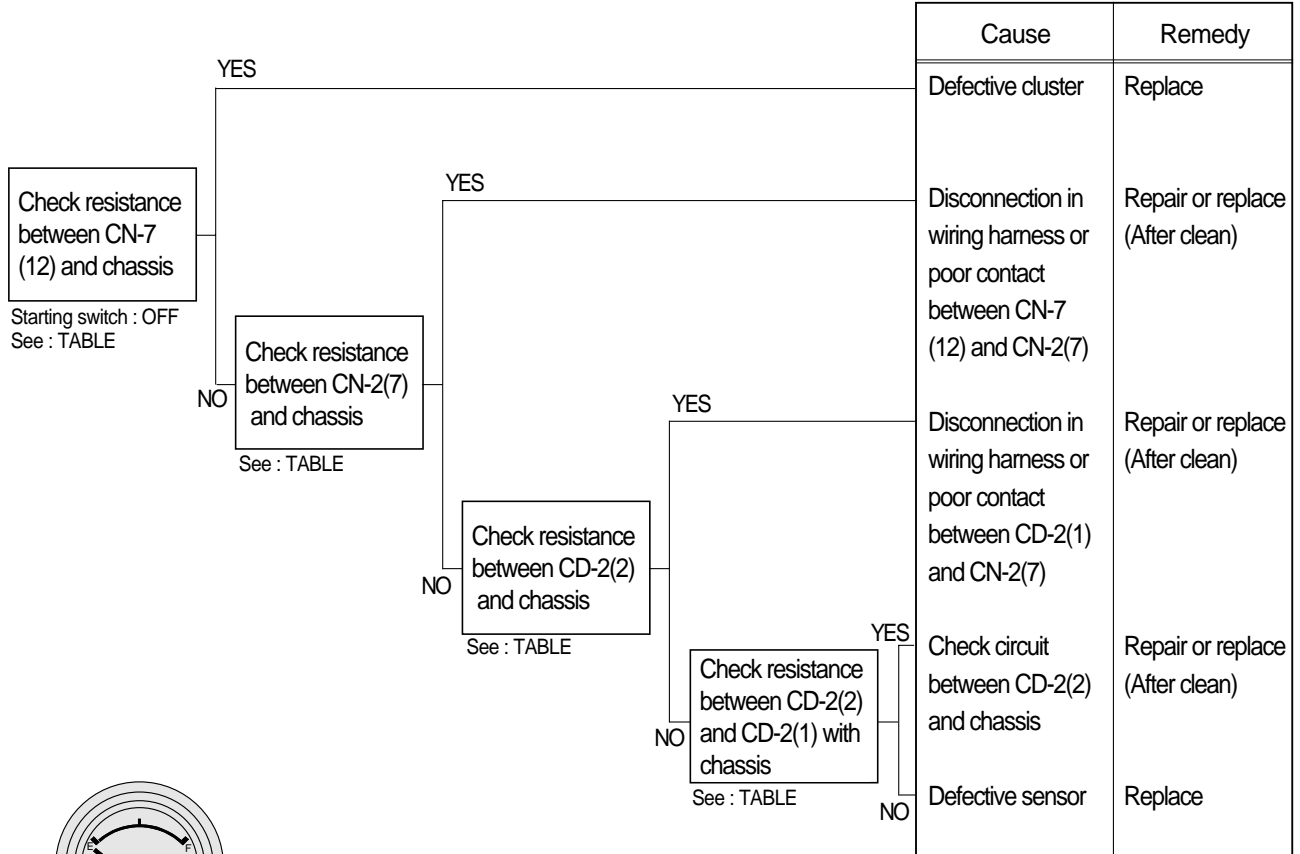

Check resistance

YES	MAX 1 Ω
NO	MIN 1M Ω

Check table

Temperature Item	Empty	(1/2)	Full
Unit resistance(Ω)	95	(32.5)	7
Tolerance	±2.5°	±5°	±2.5°
Angle	-30°	0°	+30°

9. WHEN GAUGES OF FUEL, HYDRAULIC OIL AND COOLANT INDICATE HIGH OR FULL

- Before carrying out below procedure, check all the related connectors are properly inserted.
- After checking, connect the disconnected connectors again immediately unless otherwise specified.

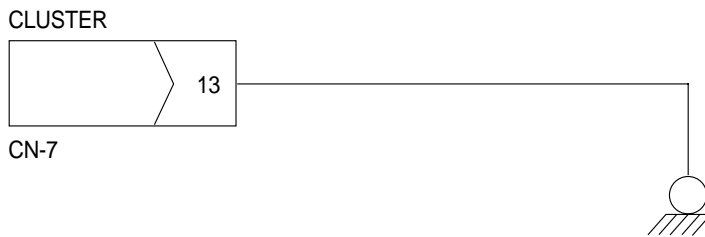
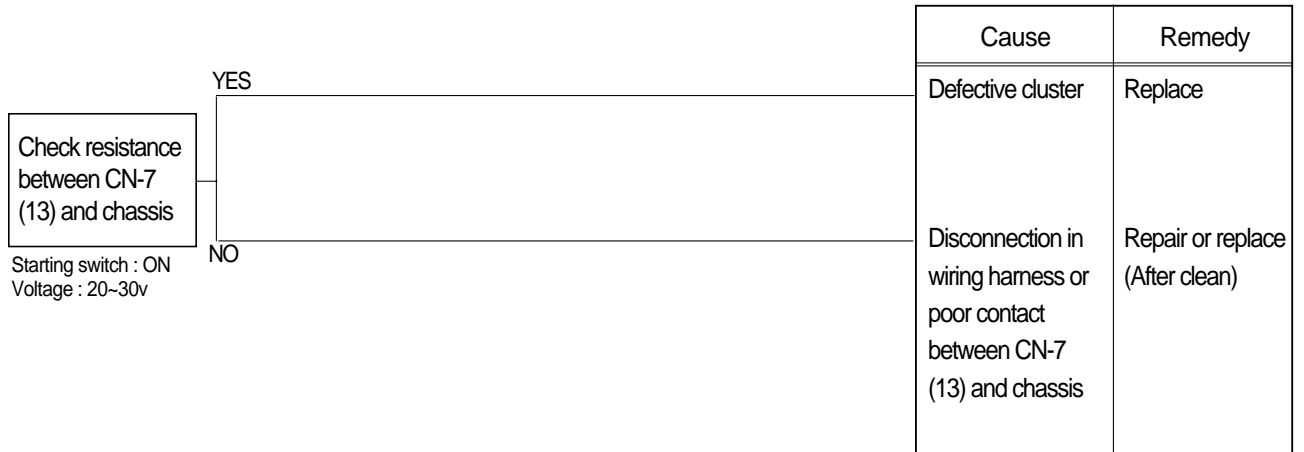

Check resistance

YES	MAX 1 Ω
NO	MIN 1M Ω

10.  **WHEN BATTERY LAMP LIGHTS UP**(Engine is started)

- Before carrying out below procedure, check all the related connectors are properly inserted.
- After checking, connect the disconnected connectors again immediately unless otherwise specified.

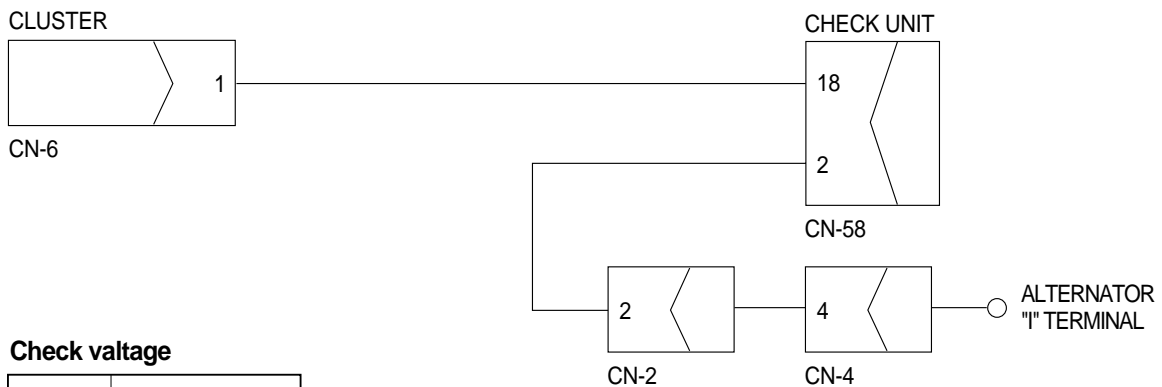
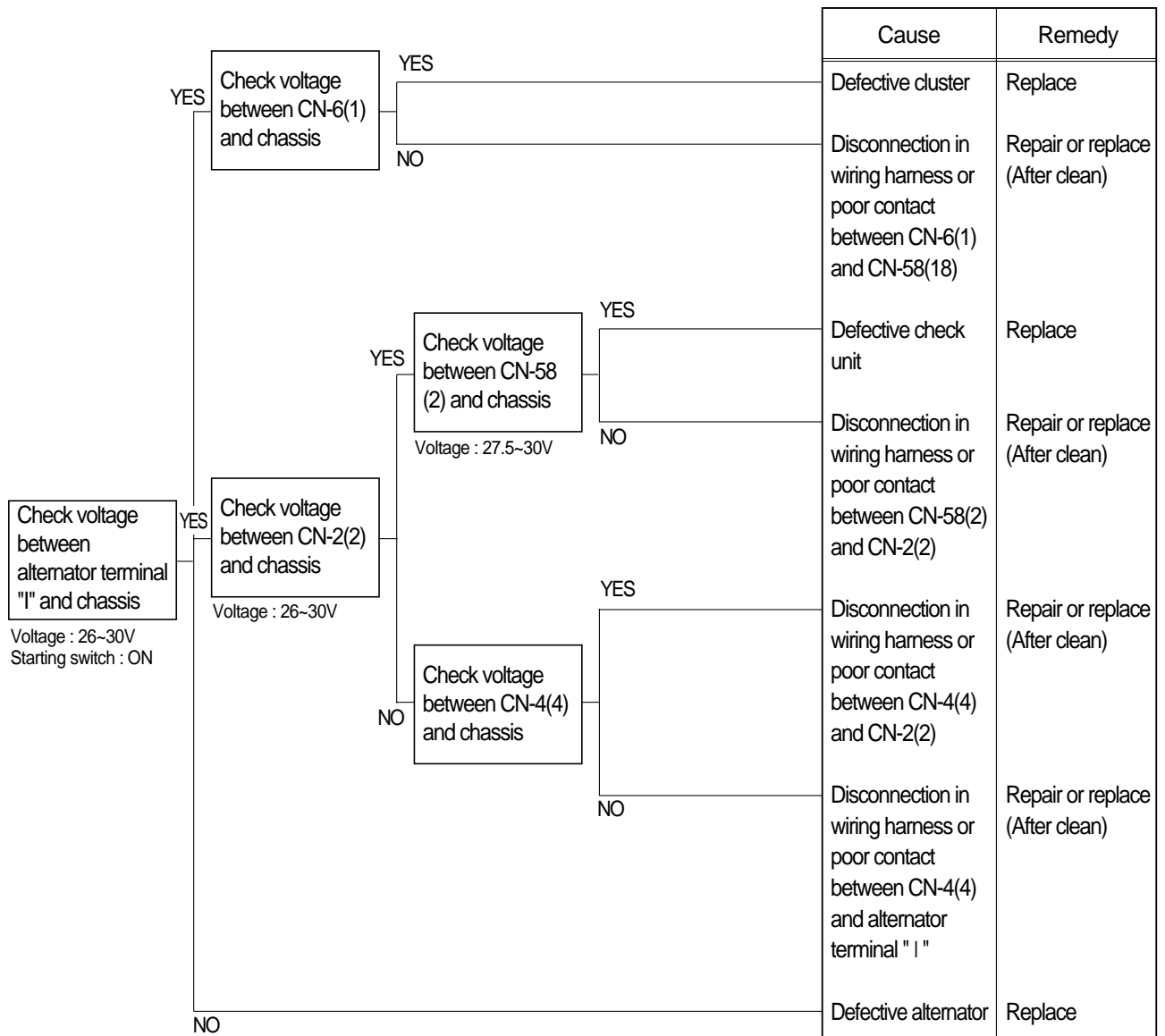

Check voltage

YES	20 ~ 30V
NO	0V

11. WHEN PARKING SOLENOID DOES NOT WORK

- Before carrying out below procedure, check all the related connectors are properly inserted and the fuse No.6 is not blown out.
- After checking, connect the disconnected connectors again immediately unless otherwise specified.

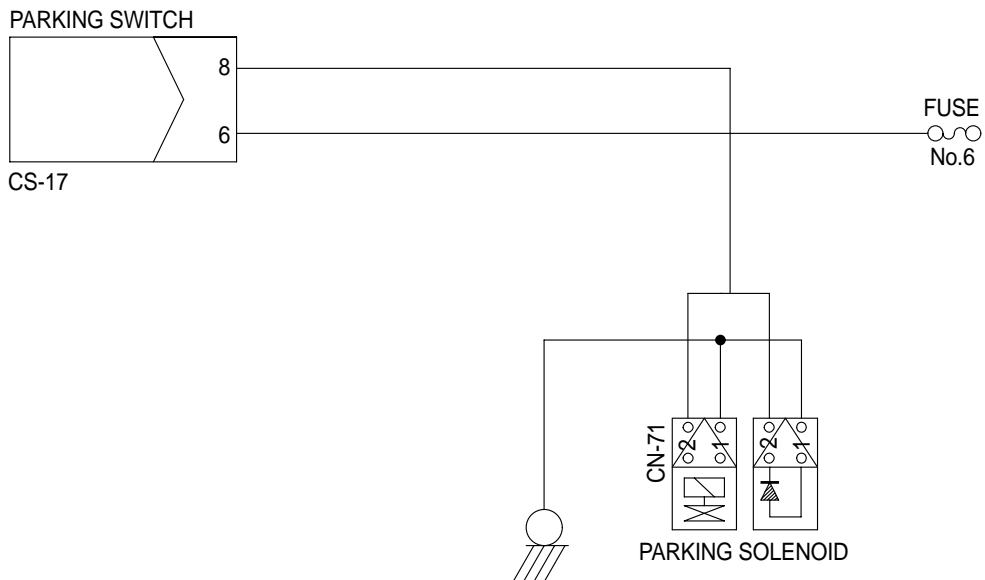
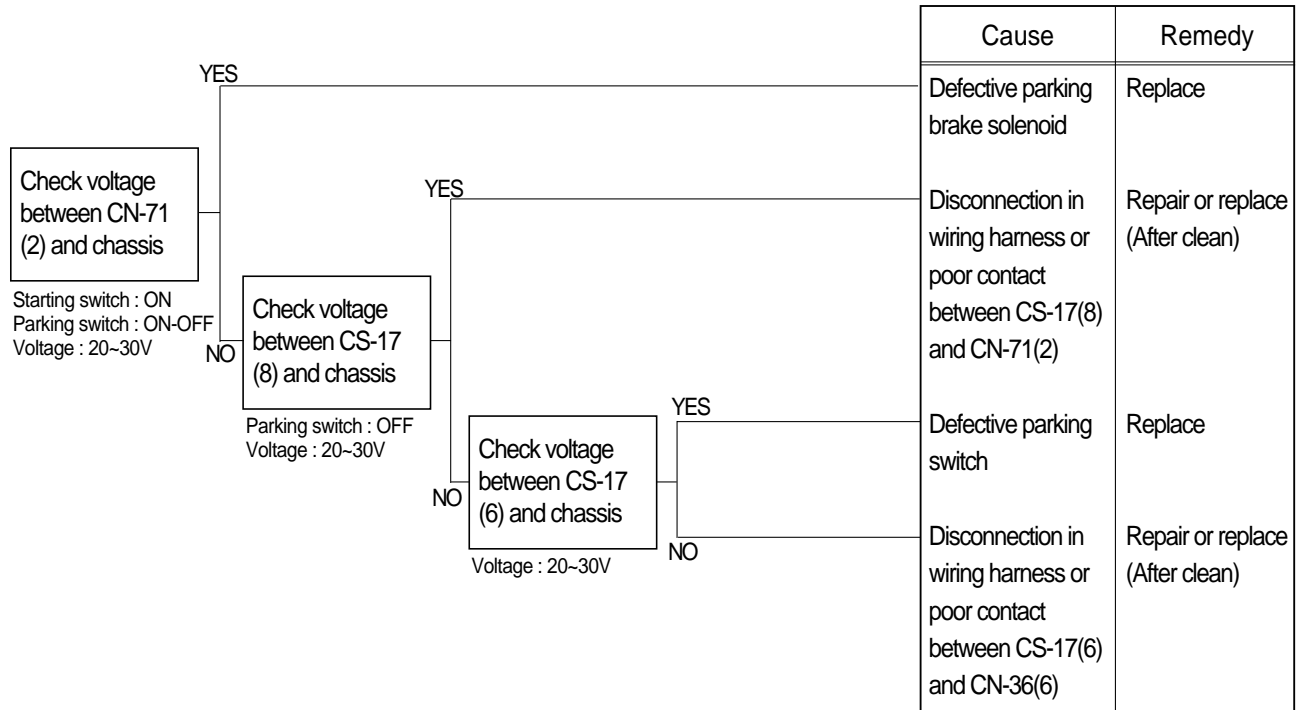

12. TRANSMISSION IS NOT RETURNED TO NEUTRAL WHEN PARKING BRAKE IS APPLIED

- Before carrying out below procedure, check all the related connectors are properly inserted and the fuse No.1(Transmission controller) and No.6 are not blown out.
- After checking, connect the disconnected connectors again immediately unless otherwise specified.

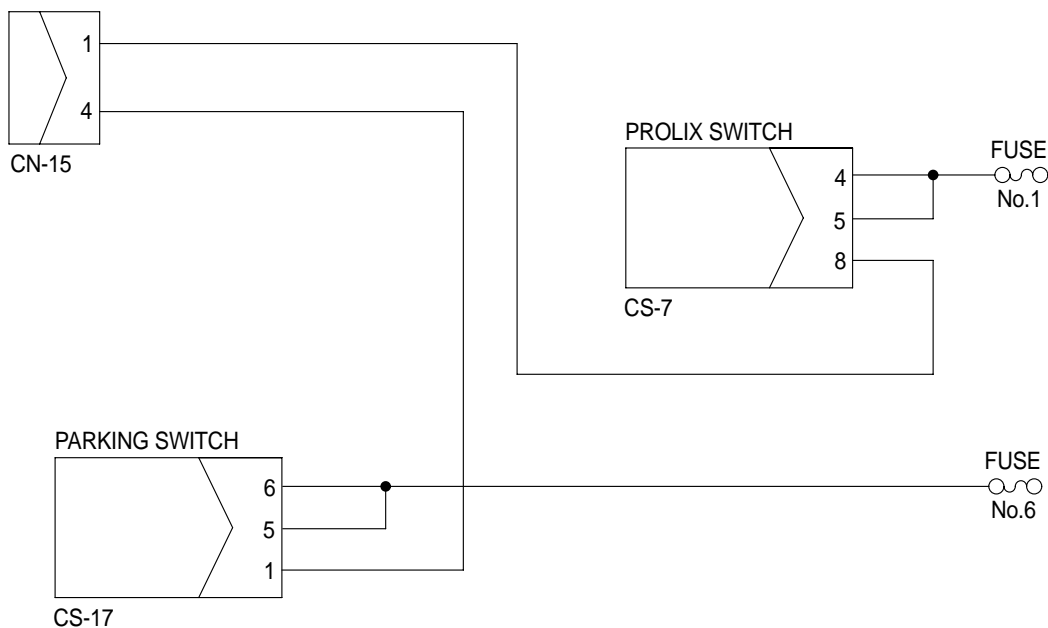
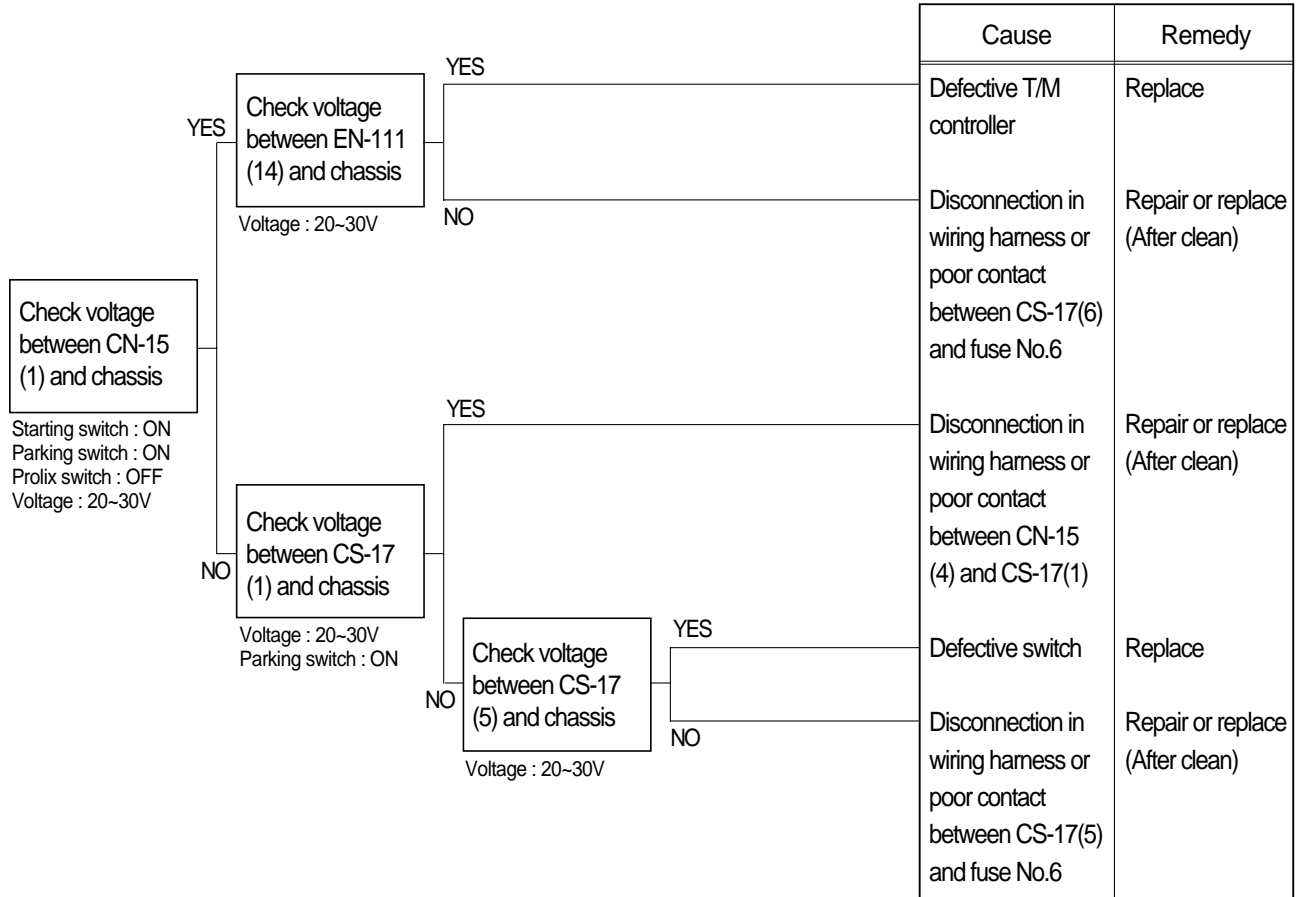

13. MACHINE DOES NOT TRAVEL

- Before carrying out below procedure, check all the related connectors are properly inserted and the fuse No.1(Transmission controller) is not blown out.
- After checking, connect the disconnected connectors again immediately unless otherwise specified.
- Wiring diagram : **See page 7-17.**

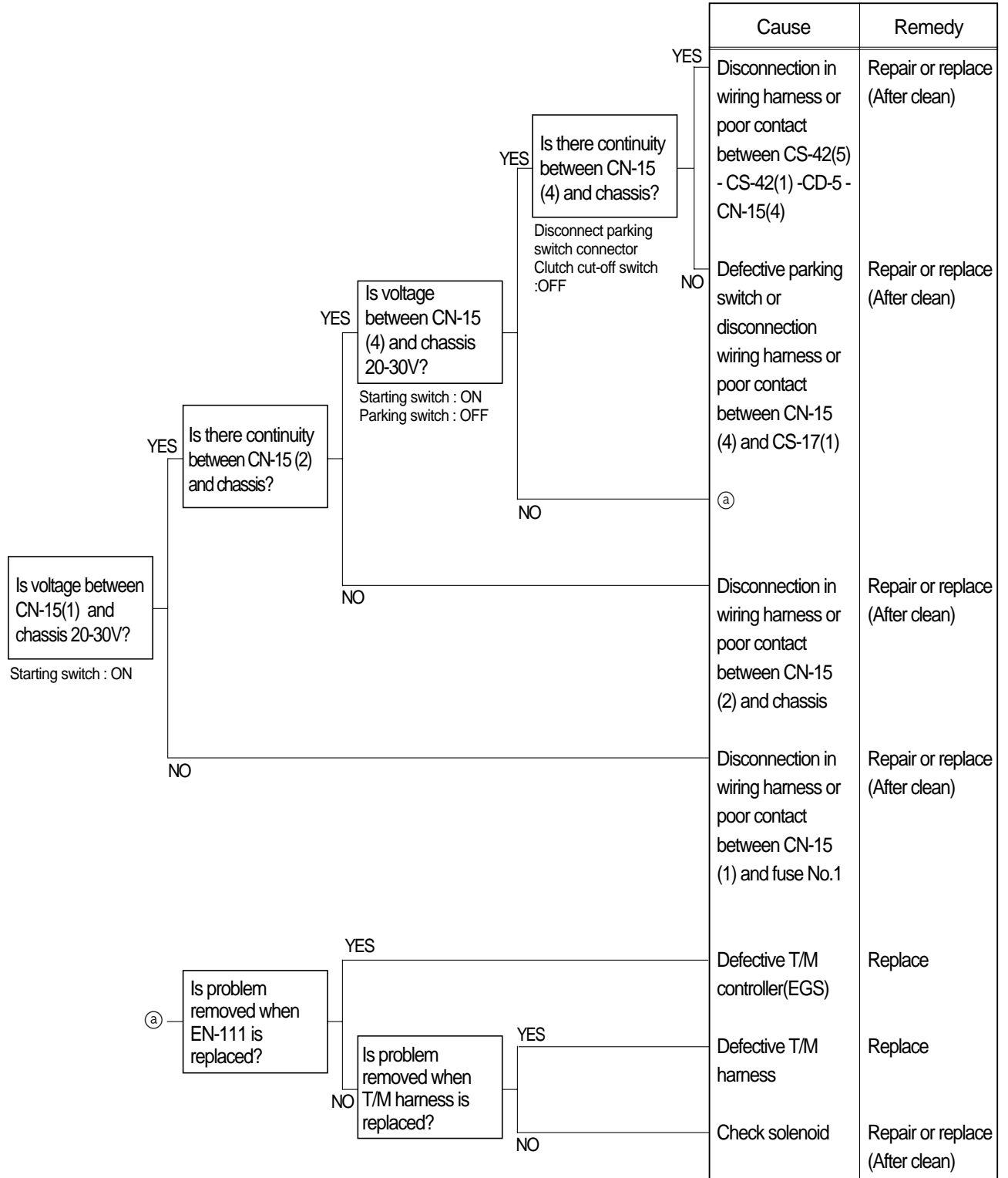

14. WHEN STARTING SWITCH IS TURNED ON, HEAD LAMP DOES NOT LIGHTS UP

- Before carrying out below procedure, check all the related connectors are properly inserted and the fuse No.19 is not blown out and ON/OFF of bulb.
- After checking, connect the disconnected connectors again immediately unless otherwise specified.

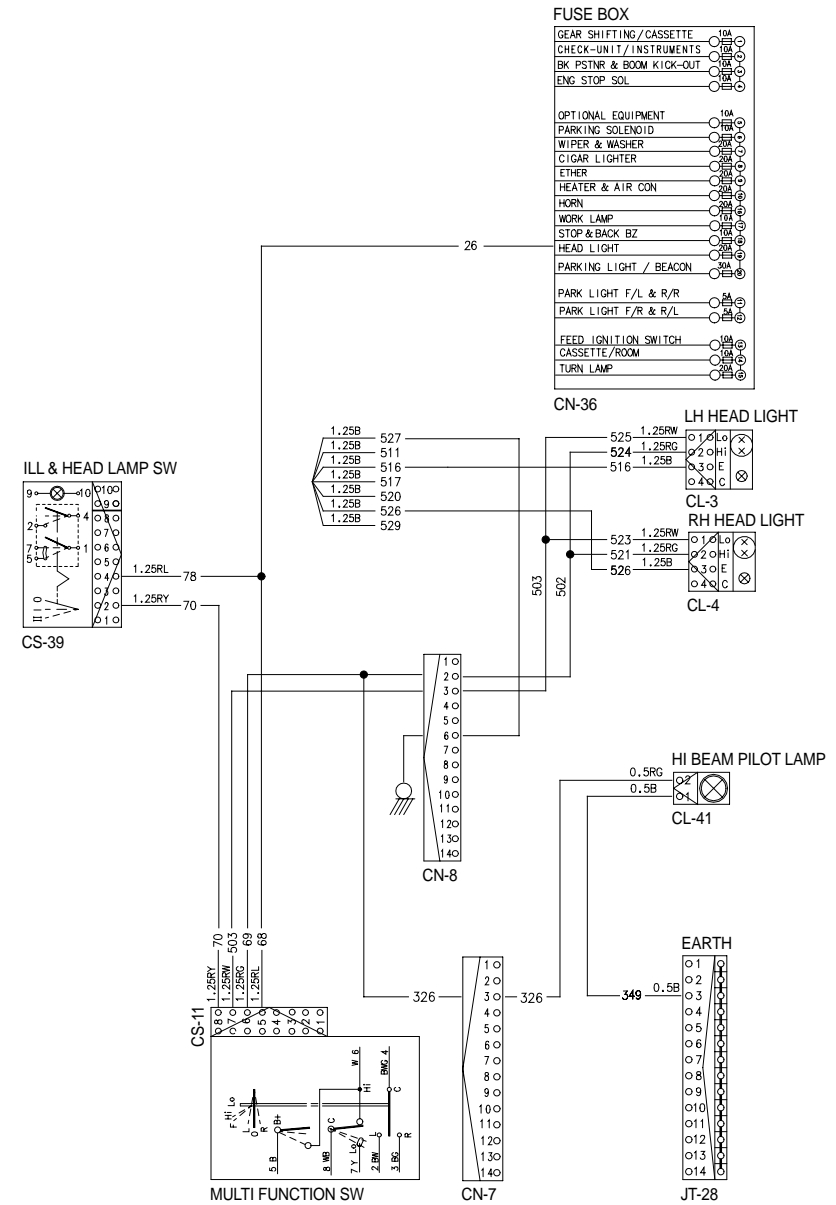
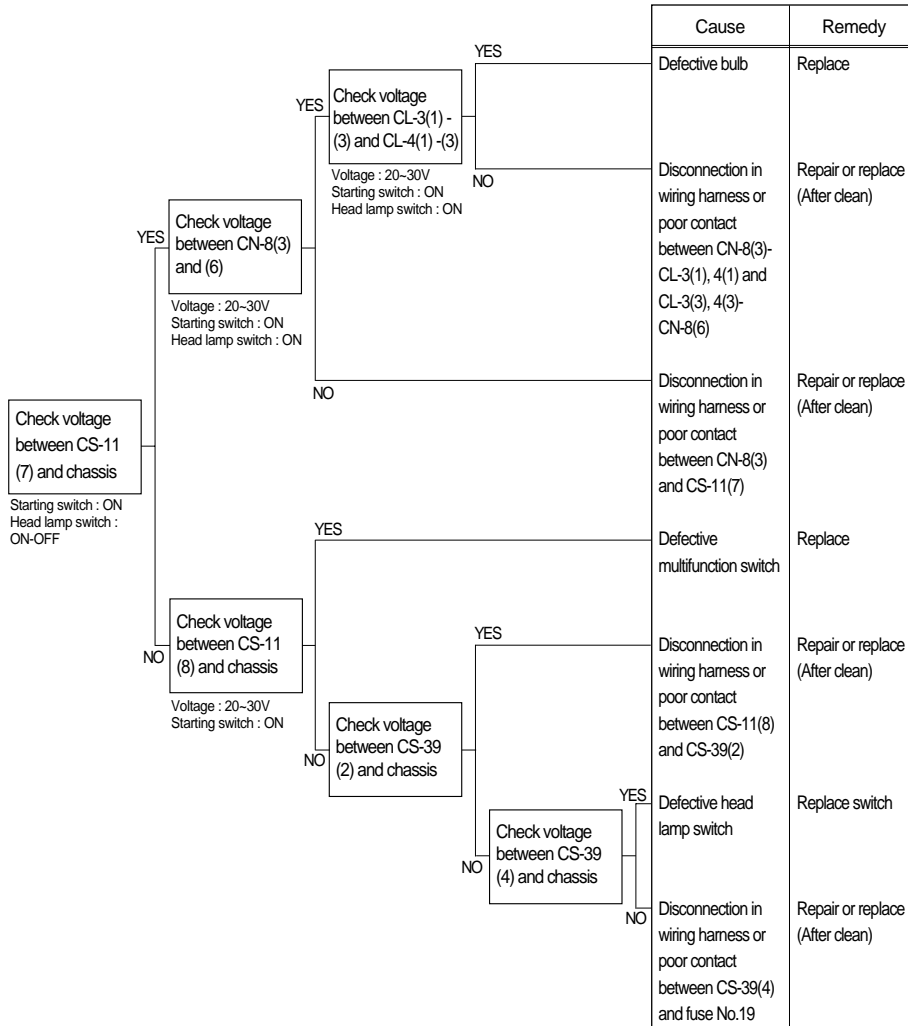

15. WHEN STARTING SWITCH IS TURNED ON, WIPER MOTOR DOES NOT OPERATE

- Before carrying out below procedure, check all the related connectors are properly inserted and the fuse No.7 is not blown out.
- After checking, connect the disconnected connectors again immediately unless otherwise specified.

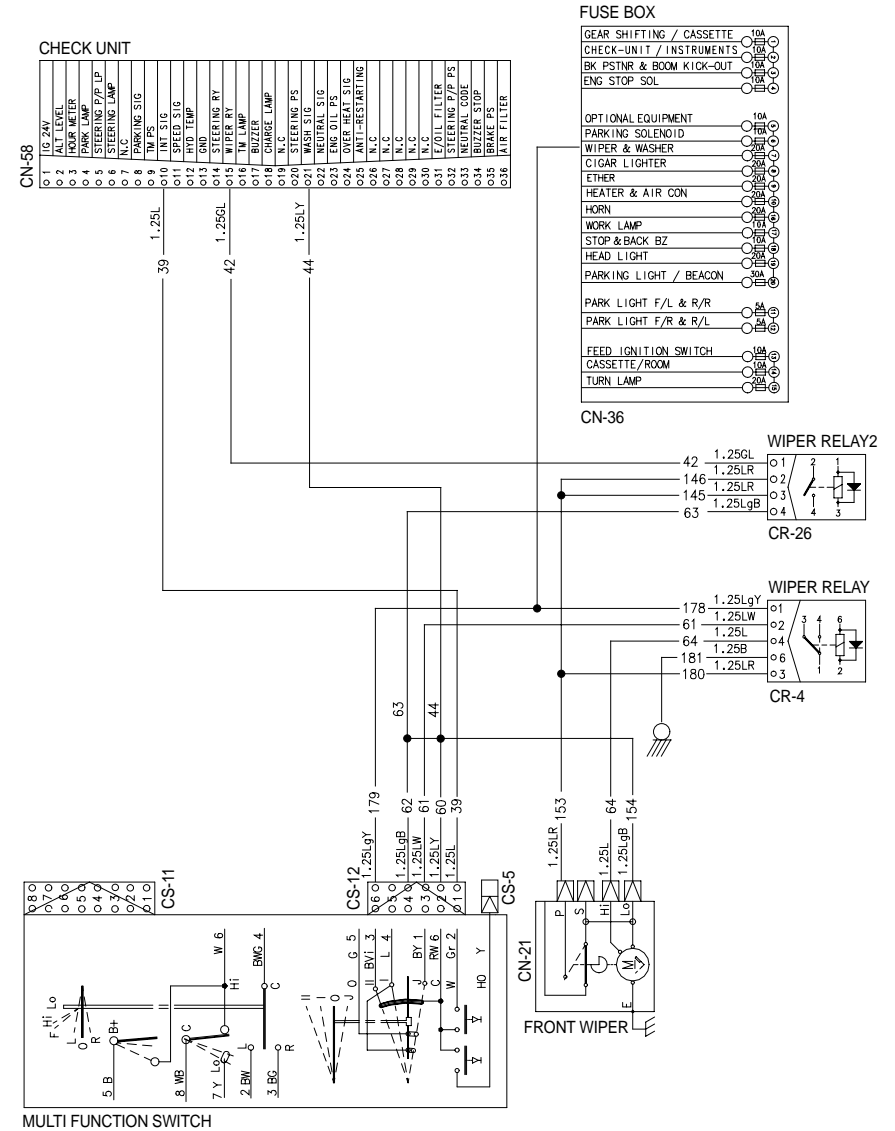
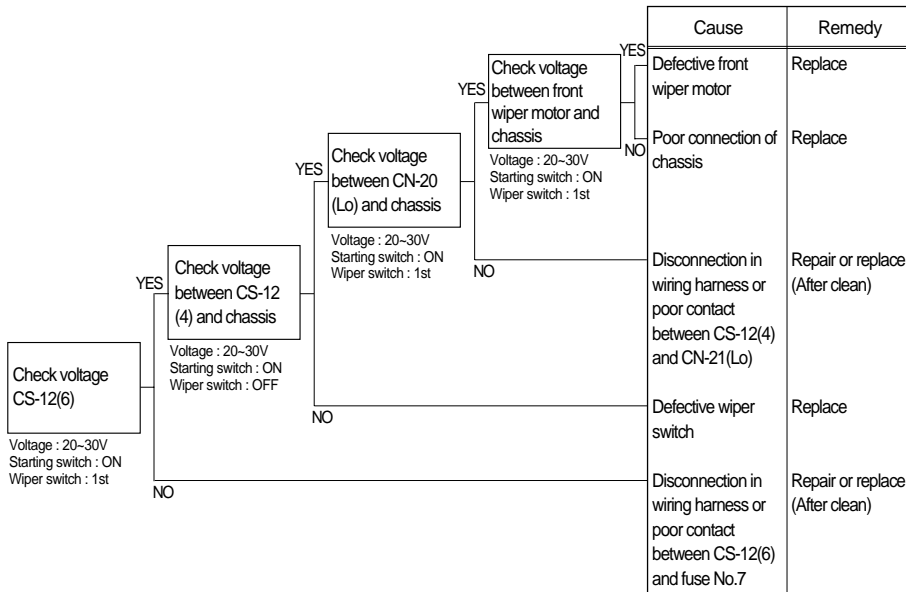

16. WHEN STARTING SWITCH ON DOES NOT OPERATE

- Before carrying out below procedure, check all the related connectors are properly inserted and and the fuse No.15 is not blown out.
- After checking, connect the disconnected connectors again immediately unless otherwise specified.

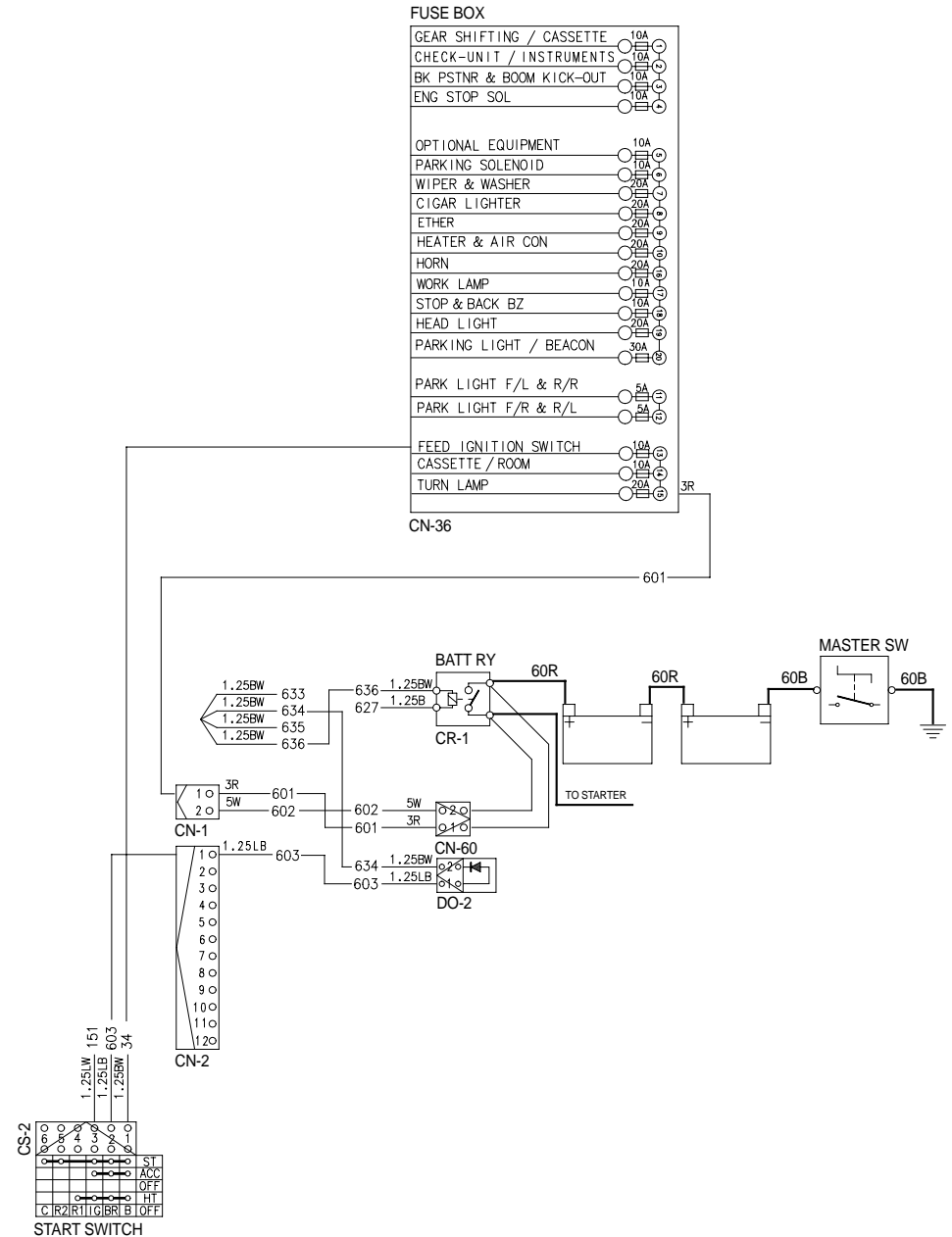
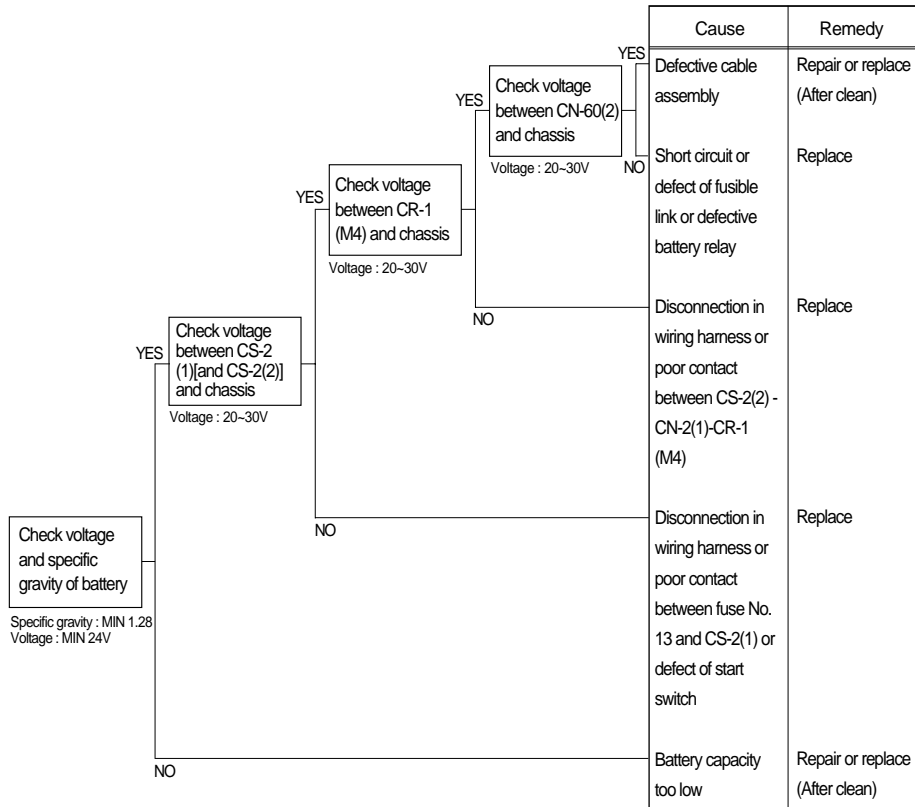

17. WHEN STARTING SWITCH IS TURNED ON, WORK LAMP DOES NOT LIGHTS UP

- Before carrying out below procedure, check all the related connectors are properly inserted, and the fuse No.16 is not blown out.
- After checking, connect the disconnected connectors again immediately unless otherwise specified.

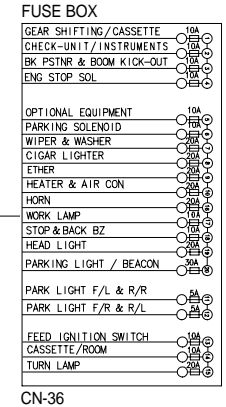
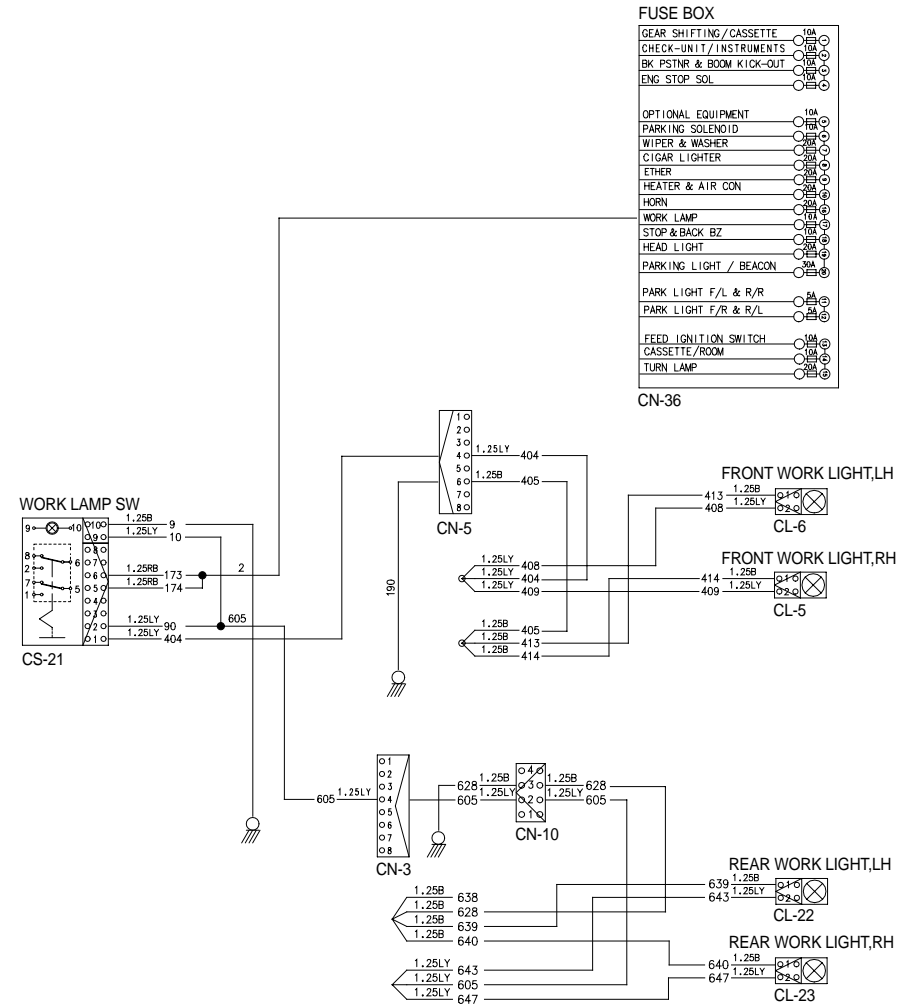
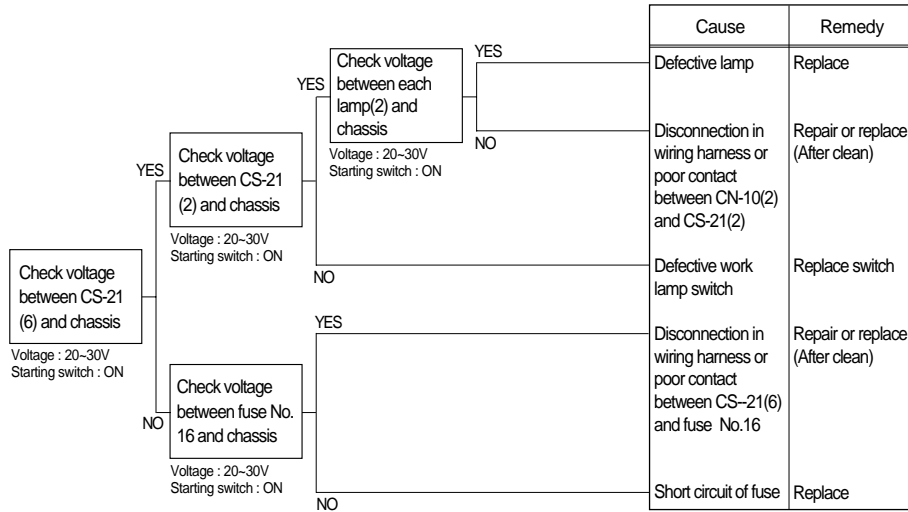

18. WHEN ENGINE DOES NOT START

- Check supply of the power at engine stop solenoid while starting switch is ON.
- Before carrying out below procedure, check all the related connectors are properly inserted.
- After checking, connect the disconnected connectors again immediately unless other wise specified.
- Check forward reverse switch at neutral position.

