

SECTION 6 WORK EQUIPMENT

GROUP 1 STRUCTURE AND FUNCTION

1. HYDRAULIC SYSTEM OUTLINE

The loader hydraulic system is a pilot operated, open center system which is supplied with flow from the fixed displacement main hydraulic pump.

The pilot control system is a low pressure, closed center hydraulic system which is supplied with flow from the first(Steering) pump.

The loader system components are :

- Main pump
- Main control valve
- Bucket cylinder
- Boom cylinders
- Pilot supply unit
- Remote control valve(Pilot control valve)
- Safety valve

The pilot supply unit consists of the pressure reducing valve, relief valve and accumulator.

Flow from the main hydraulic pump not used by the steering system leaves the priority valve EF port. It flows to the inlet port plate of a mono block type main control valve.

The main control valve is a tandem version spool type, open center valve which routes flow to the boom, bucket or auxiliary cylinders(Not shown) when the respective spools are shifted.

Flow from the steering pump(The first pump) is routed to the pilot supply unit where the steering pump outlet pressure is reduced to pilot circuit pressure. The pilot supply unit flow to the remote control valve.

The remote control valve routed flow to either end of each spool valve section in the main control valve to control spool stroke.

A accumulator mounted on pilot supply unit supplies a secondary pressure source to operated remote control valve so the boom can be lowered if the engine is off.

The return circuit for the main hydraulic system have return filter inside the hydraulic tank. The return filter uses a filter element and a bypass valve. The bypass valve is located in the upside of filter.

2. HYDRAULIC CIRCUIT

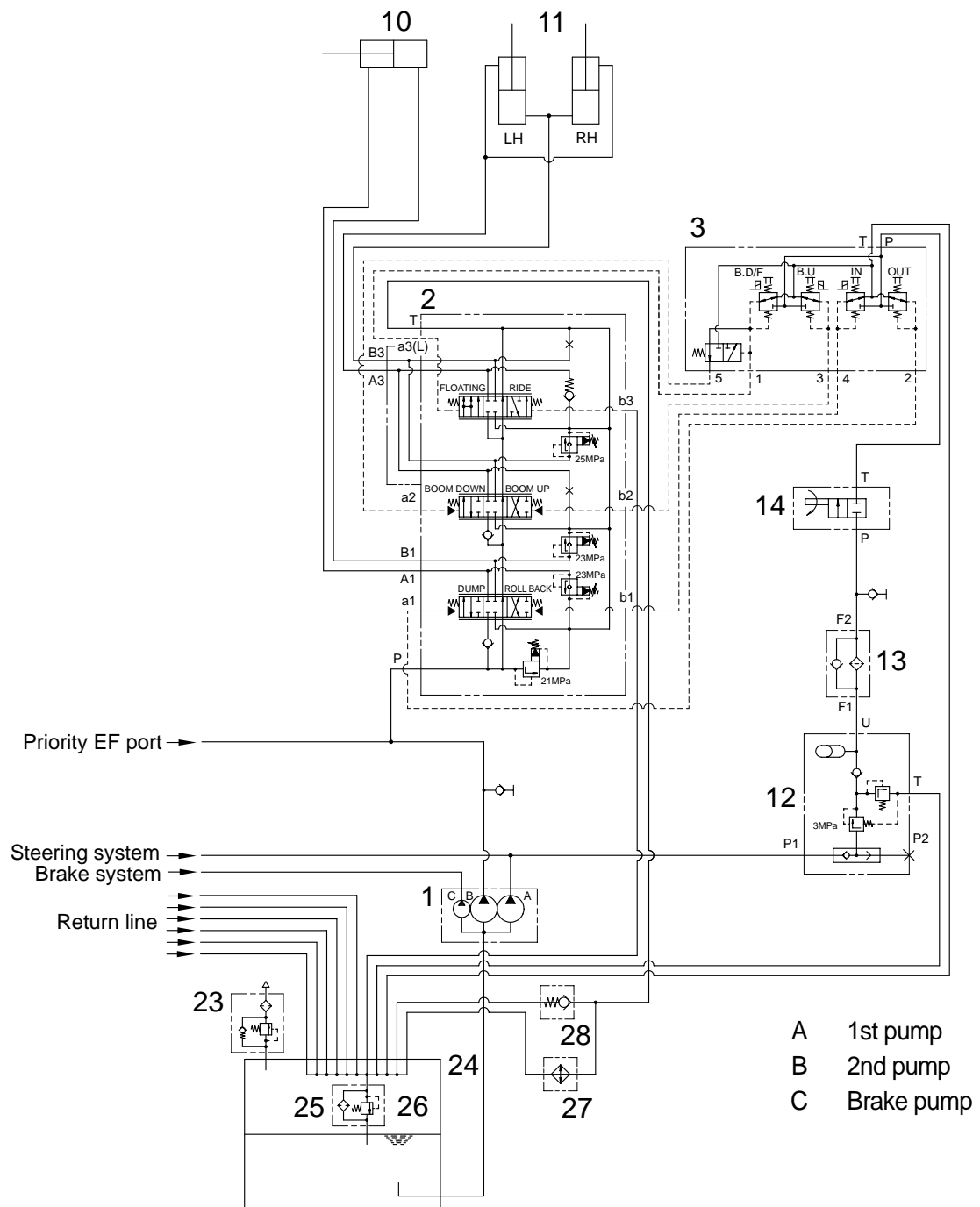

- | | | | | | |
|----|----------------------|----|-------------------|----|-----------------------|
| 1 | Main pump | 12 | Pilot supply unit | 25 | Return filter |
| 2 | Main control valve | 13 | Line filter | 26 | Bypass valve |
| 3 | Remote control valve | 14 | Safety valve | 27 | Oil cooler(Optional) |
| 10 | Bucket cylinder | 23 | Air breather | 28 | Check valve(Optional) |
| 11 | Boom cylinder | 24 | Hydraulic tank | | |

1) WHEN THE RCV LEVER IS IN THE RAISE POSITION

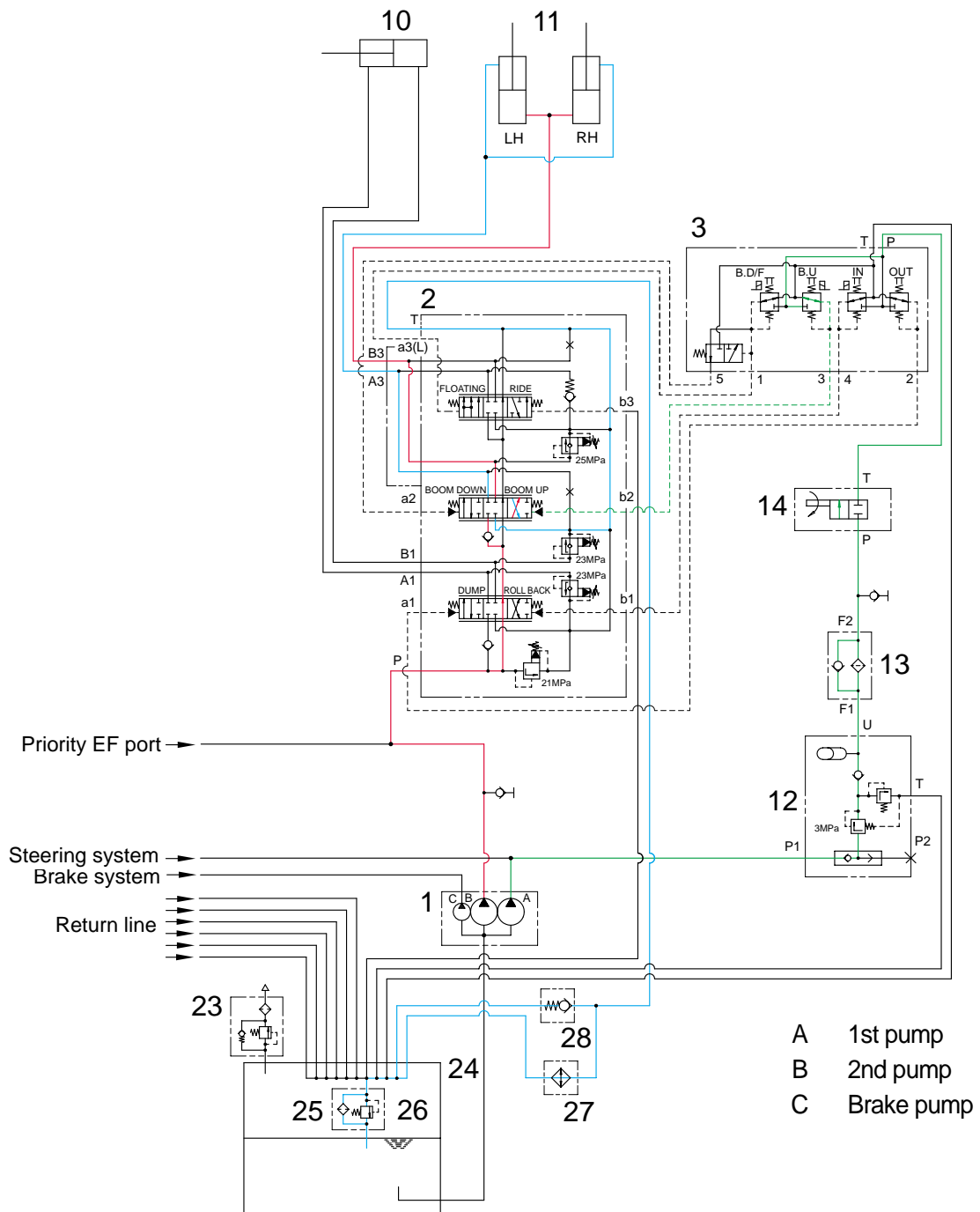

- When the RCV lever(3) is pulled back, the boom spool on the second block is moved to raise position by pilot oil pressure from port 3 of RCV.
- The oil from main pump(1) flows into main control valve(2) and then goes to the large chamber of boom cylinder (11) by pushing the load check valve of the boom spool through center bypass circuit of the bucket spool.
- The oil from the small chamber of boom cylinder(11) returns to hydraulic oil tank(24) through the boom spool at the same time.
- When this happens, the boom goes up.

2) WHEN THE RCV LEVER IS IN THE LOWER POSITION

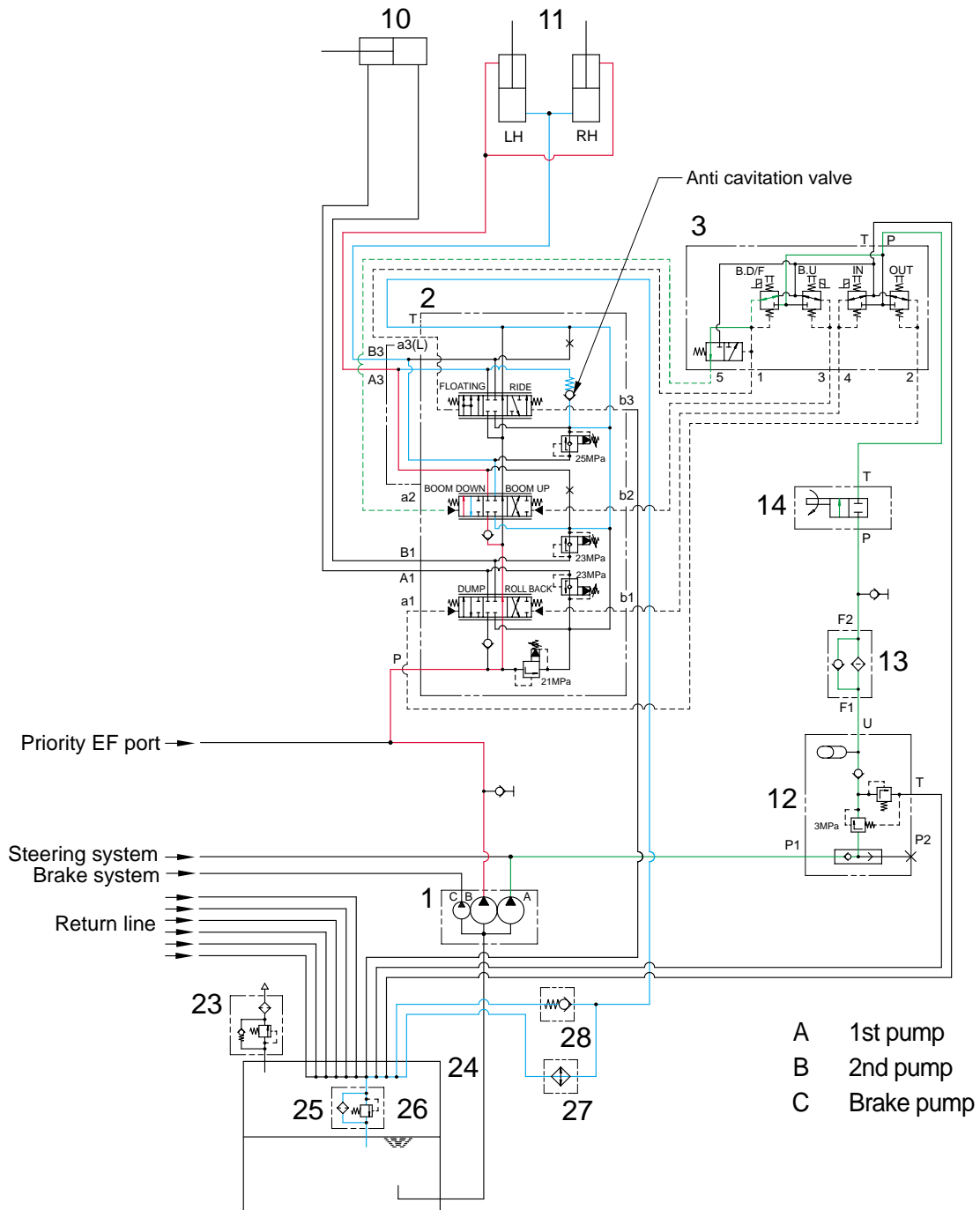

- When the RCV lever(3) is pushed forward, the boom spool on the second block is moved to lower position by pilot pressure from port 5 of RCV.
- The oil from main pump(1) flows into main control valve and then goes to small chamber of boom cylinder(11) by pushing the load check valve of the boom spool through center bypass circuit of the bucket spool.
- The oil returned from large chamber of boom cylinder(11) returns to hydraulic tank(24) through the boom spool at the same time.
- When the lowering speed of boom is faster, the return oil from the large chamber of boom cylinder combines with the oil from the pump through the anti cavitation valve, and flows into the small chamber of the cylinder. This prevents cylinder cavitation by the negative pressure when the pump flow cannot match the boom down speed.

5) WHEN THE RCV LEVER IS IN THE ROLL BACK(retract) POSITION

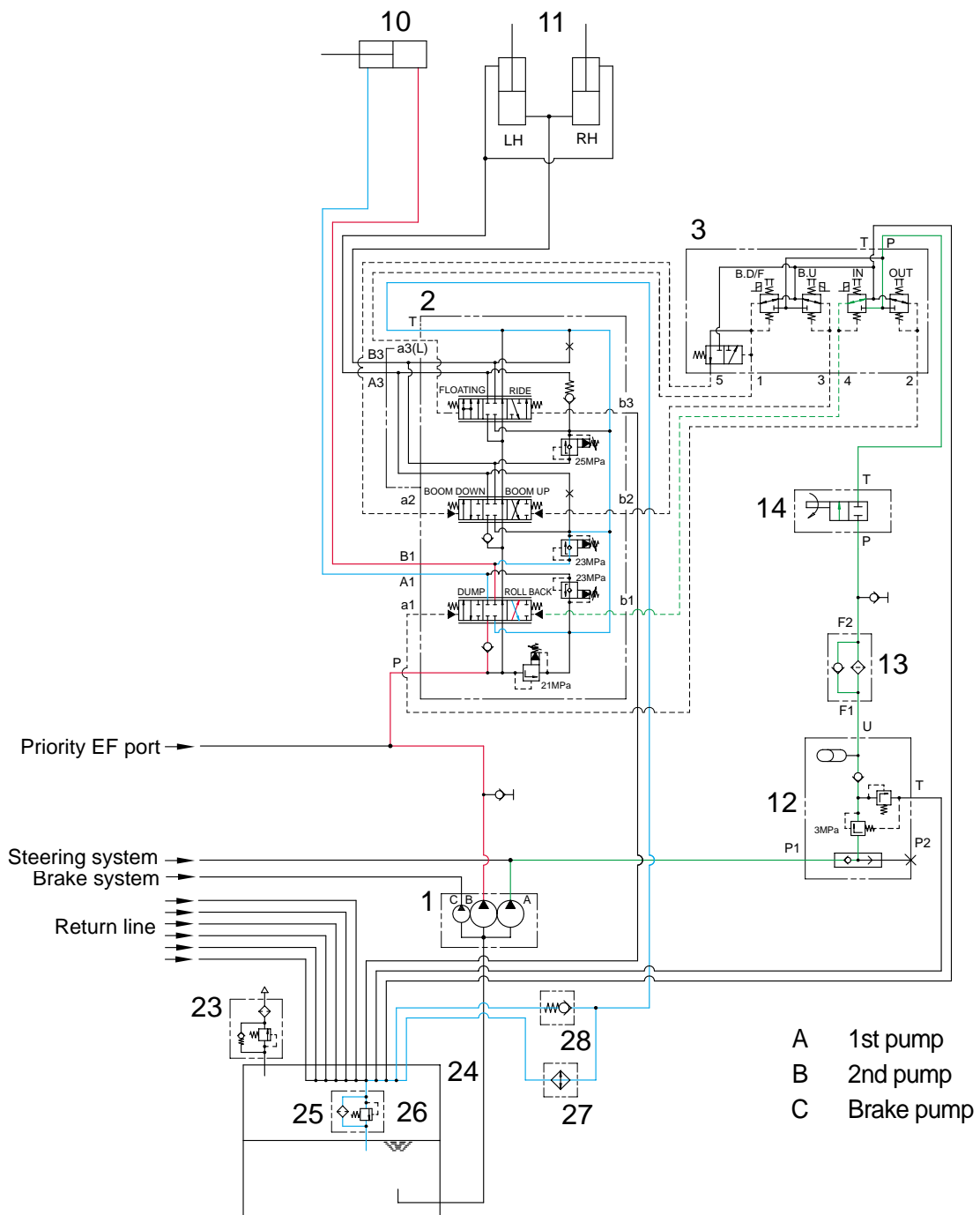

- If the RCV lever(3) is pulled left, the bucket spool on the first block is moved to roll back position by pilot oil pressure from port 4 of RCV.
- The oil from main pump(1) flows into main control valve(2) and then goes to the large chamber of bucket cylinder by pushing the load check valve of the bucket spool.
- The oil at the chamber of bucket cylinder(10) returns to hydraulic tank(24) through the bucket spool.
- When this happens, the bucket roll back.
- When the rolling speed of bucket is faster, the return oil from the small chamber of bucket cylinder combines with the oil from the pump, and flows into the large chamber of the cylinder. This prevents cylinder cavitation by the negative pressure when the pump flow cannot match the bucket rolling speed.

3. MAIN PUMP OPERATION

1) STRUCTURE

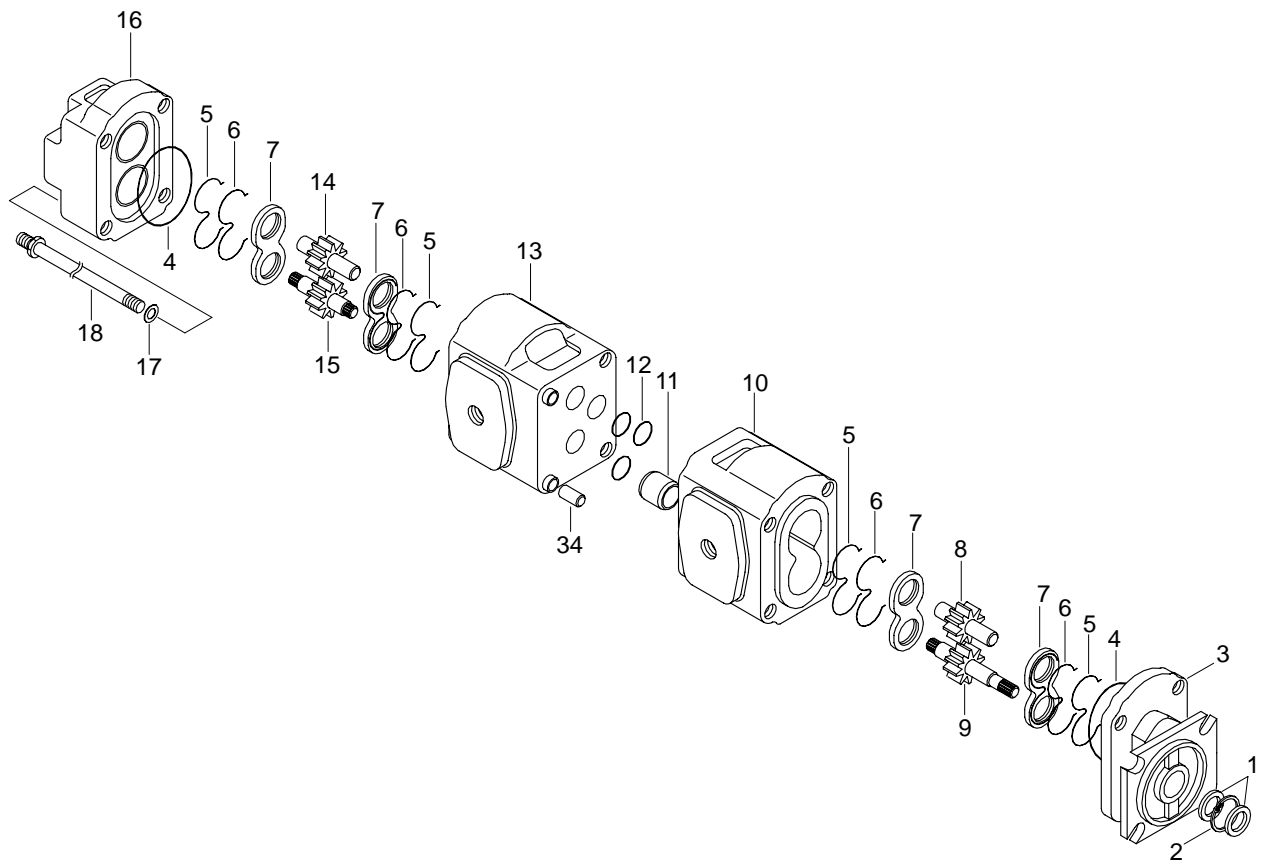

- | | | | | | |
|---|---------------|----|------------------|----|-------------|
| 1 | Shaft seal | 8 | Driven gear | 14 | Driven gear |
| 2 | Circlip | 9 | Drive gear | 15 | Drive shaft |
| 3 | Flange | 10 | Front body | 16 | Cover |
| 4 | O-ring | 11 | Splined coupling | 17 | Washer |
| 5 | Seal | 12 | O-ring | 18 | Stud assy |
| 6 | Seal | 13 | Center body | 34 | Dowel |
| 7 | Balance plate | | | | |

2) OPERATION

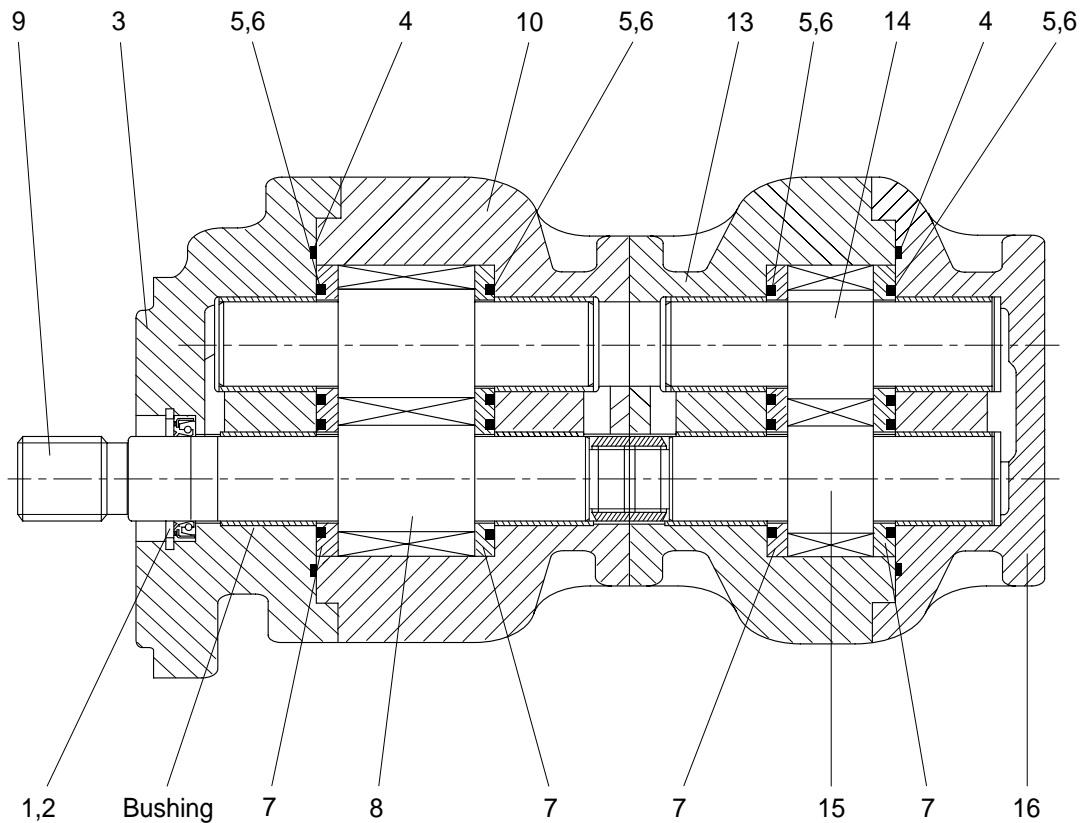

The main hydraulic pump is a fixed displacement gear type pump. The pump is drive at engine speed by the transmission. The pump shafts are supported by bushings in the flange assembly(3), front body(10), rear body(13) and cover(16).

As the drive gear(9) and shaft(15) turns the idler gears(8, 14), the gear teeth come out of mesh. Oil flows from the hydraulic tank through the inlet into the cavity between the gear teeth. As the gears continue to rotate, the oil becomes trapped between the gear teeth and the balance plates(7).

The trapped oil is then carried to the pump outlet. Oil is forced out the outlet to supply the hydraulic function. As the gears re-mesh, they form a seal to prevent oil from flowing between the gears and back to the inlet.

The pump uses outlet pressure oil to load the balance plates(7) against the gear faces. This controls internal leakage to maintain pump displacement.

Outlet pressure fills the area bounded by the seals(5, 6) to force the pressure plate against the high pressure area or the gear faces. Pump shaft lubrication is achieved by routing outlet pressure oil into the area between the gear shafts and the bushings. The oil is collected at the end of the shafts in the hollow areas in the port and flange plates and routed back to return.

4. REMOTE CONTROL VALVE

1) STRUCTURE (1/3)

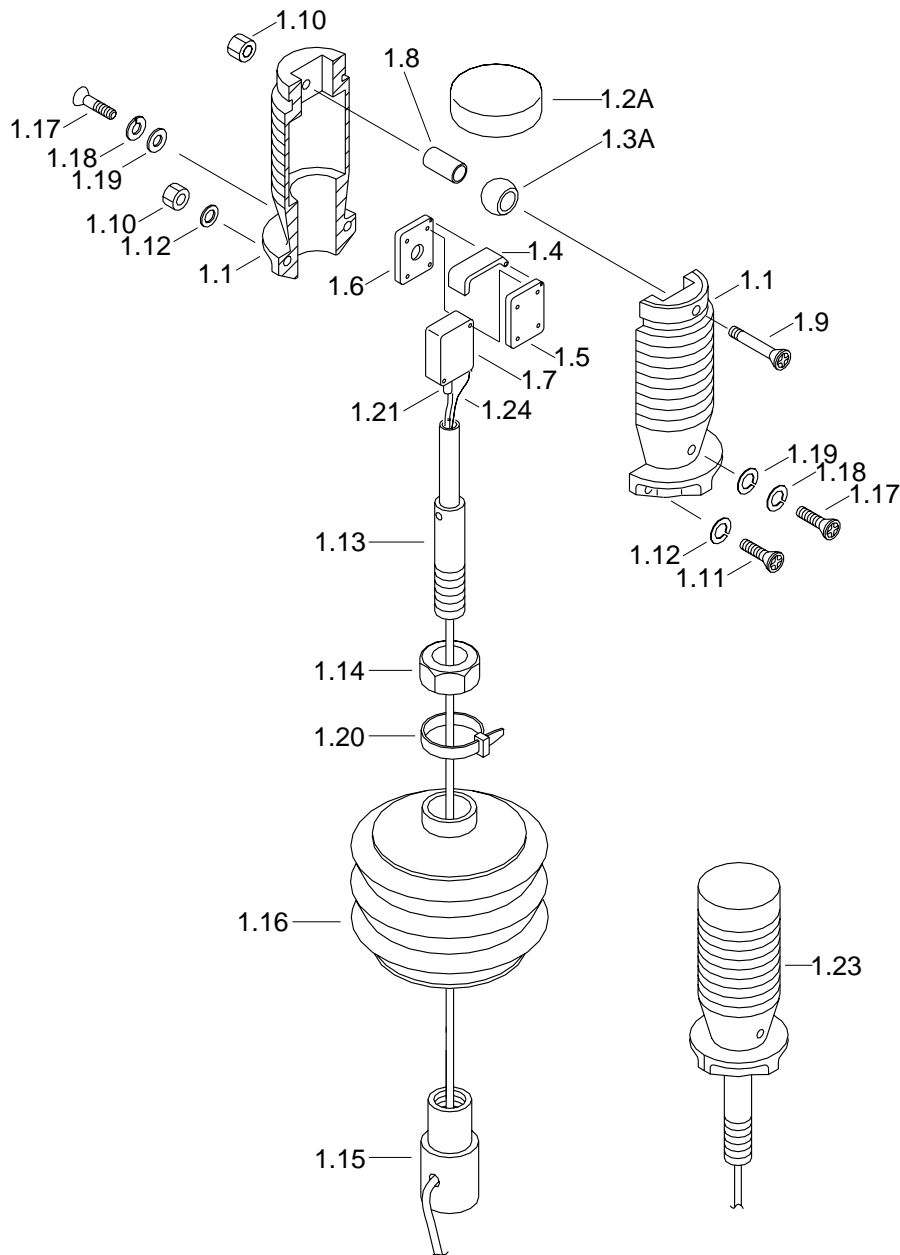

1.1	Half handle	1.9	Screw	1.17	Screw
1.2A	Insulation cap	1.10	Self locking nut	1.18	Lock washer
1.3A	Pusher	1.11	Screw	1.19	Belleville washer
1.4	Rocker arm	1.12	Washer	1.20	Fitting clamp
1.5	Spacer	1.13	Hollow lever	1.21	Thimble
1.6	Spacer	1.14	Nut	1.23	Complete handle
1.7	Contact switch	1.15	Nut	1.24	Cable
1.8	Spacer	1.16	Bellows		

STRUCTURE (2/3)

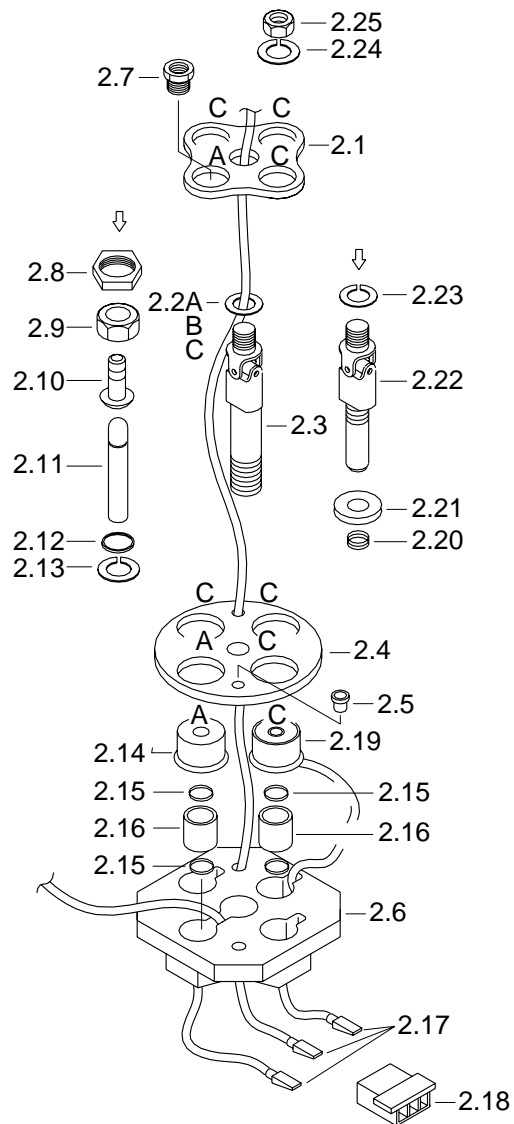

2.1	Bracket	2.8	Counter nut	2.17	Connector blade
2.2A	Shim	2.9	Nut	2.18	Junction box
2.2B	Shim	2.10	Press screw	2.19	Complete solenoid
2.2C	Shim	2.11	Plunger	2.20	Spring ring
2.3	Joint	2.12	Circlip	2.21	Armature
2.4	Flange	2.13	Shim	2.22	Joint
2.5	Plug	2.14	Plunger guide	2.23	Friction washer
2.6	Electric bracket	2.15	O-ring	2.24	Friction washer

STRUCTURE (3/3)

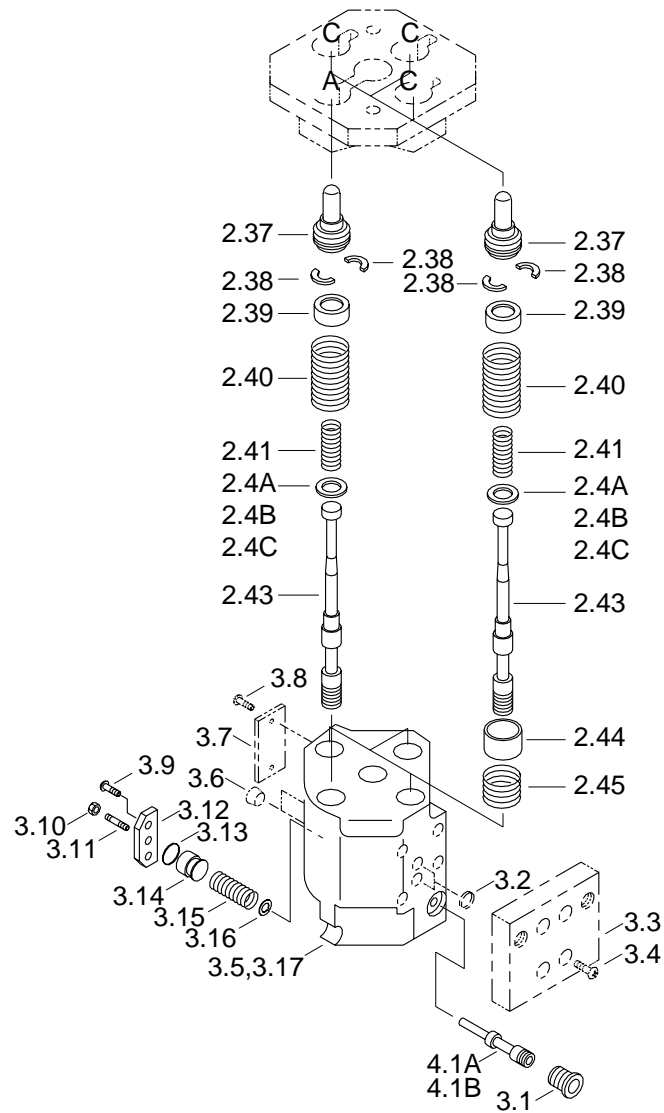

2.37	Complete plunger	2.45	Spring	3.10	Nut
2.38	1/2 Washer	3.1	Plug	3.11	Screw
2.39	Spring retainer	3.2	O-ring	3.12	Plate
2.40	Spring	3.3	Intermediate plate	3.13	O-ring
2.41	Spring	3.4	Screw	3.14	Piston
2.4A	Shim	3.5	Housing	3.15	Spring
2.4B	Shim	3.6	Plug	3.16	Washer
2.4C	Shim	3.7	Identification plate	3.17	Housing
2.43	Spool	3.8	Pin	4.1A	Spool
2.44	Socket	3.9	Screw	4.2A	Spool

2) OPERATION

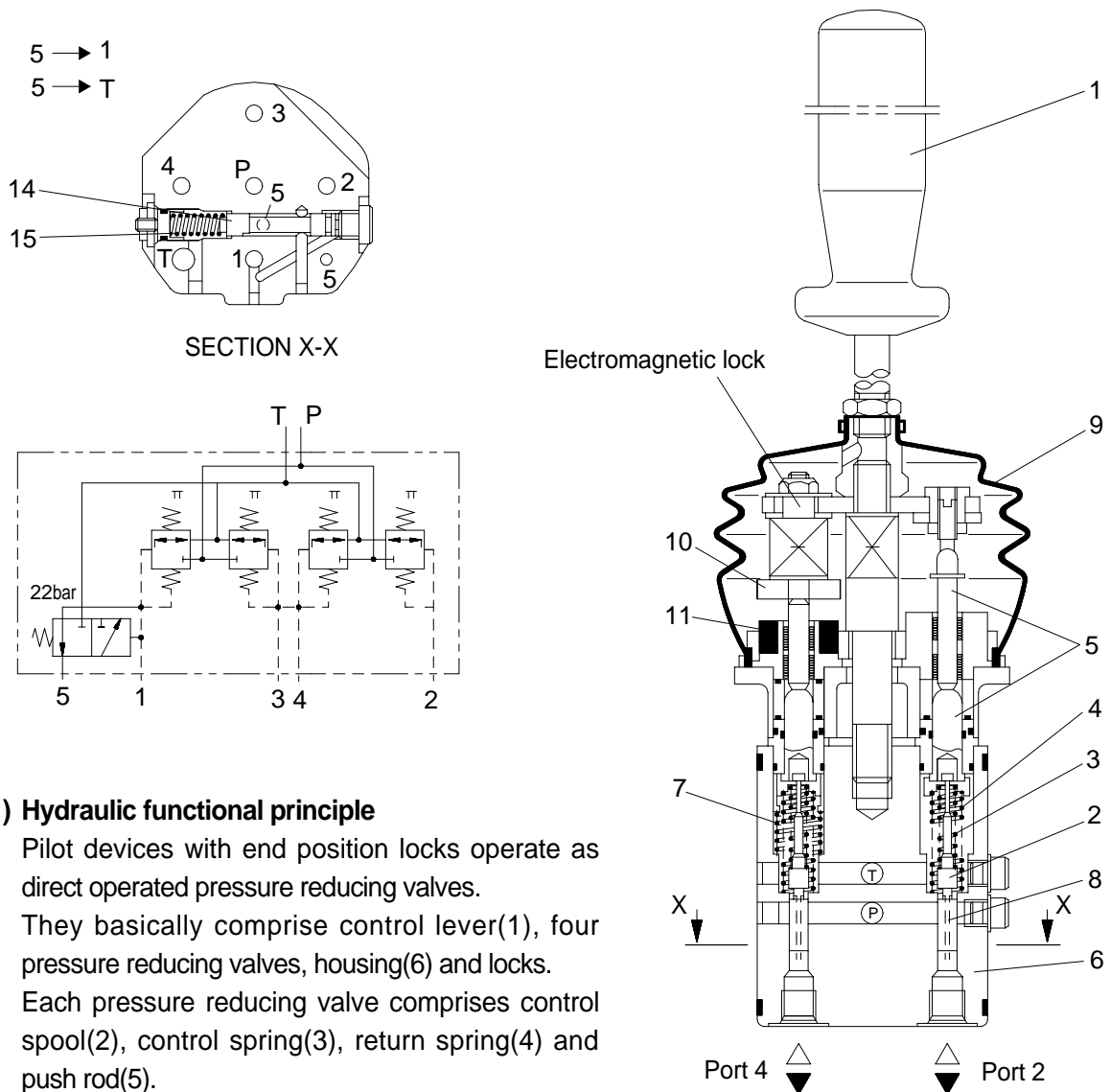

(1) Hydraulic functional principle

Pilot devices with end position locks operate as direct operated pressure reducing valves.

They basically comprise control lever(1), four pressure reducing valves, housing(6) and locks.

Each pressure reducing valve comprises control spool(2), control spring(3), return spring(4) and push rod(5).

At rest control lever(1) is held in its neutral position by return springs(4). Ports(1, 2, 3, 4) are connected to tank port T via bore(8).

When control lever(1) is deflected push rod(5) is pressed against return spring(4) and control spring(3).

Control spring(3) initially moves control spool(2) downwards and closes the connection between the relevant port and tank port T. At the same time the relevant port is connected to port P via bore(8). The closed loop control phase starts, as soon as control spool(2) finds its balance between the force from control spring(3) and the force, which results from the hydraulic pressure in the relevant port(port 1, 2, 3 or 4).

Due to the interaction between control spool(2) and control spring(3) the pressure in the relevant port is proportional to the stroke of push rod(5) and hence to the position of control lever(1).

This closed loop pressure control dependent on the position of the control lever and the characteristics of the control spring permits the proportional hydraulic control of the main directional valve.

Rubber sleeve(9) protects the mechanical components in the housing from contamination.

(2) End position lock

Only those control ports, for which it is necessary to hold the control lever in a deflected position are equipped with end position locks.

Electromagnetic lock

An additional spring(7) under push rod(5) warns, due to the increase in force which is required to keep this spring compressed, that the stroke of push rod(5) and control lever(1) is nearly at its end.

Once this point has been exceeded ring(10) is placed in contact with solenoid armature(11).

If the solenoid is energized, control lever(1) is held in its end position by means of the electromagnetic force.

The lock is released automatically when the solenoid is deenergized.

(3) Fifth control port

This remote control valve is equipped with a fifth control port, which is used to control the boom floating function. This function may be operated by moving spool(14) against spring(15) under the influence of the pressure acting in port 1.

As soon as this pressure reaches 22bar, control port 5 is connected with T.

5. MAIN CONTROL VALVE

1) STRUCTURE

11	Housing	79.1	O-ring	90	Compression spring
13	Short cover	80	Port relief valve	91	Compression spring
18	Long cover	80.1	Lock nut seal	92	Compression spring
40	Spool	80.2	Piston seal	98	Compression spring
41	Spool	80.3	O-ring	99	Bleed screw
45	Spring retainer	80.4	O-ring	104	Snap ring
54	Bleed screw	82	Main relief valve	107	Seal ring
56	Locking screw	82.1	O-ring	124	O-ring
57	Cone	82.2	O-ring	300	Plate
59	Locking screw	82.3	Thrust ring	301	Bolt
78	Locking screw	82.4	O-ring	302	O-ring
79	Check valve	88	compression spring	303	Locking screw

STRUCTURE

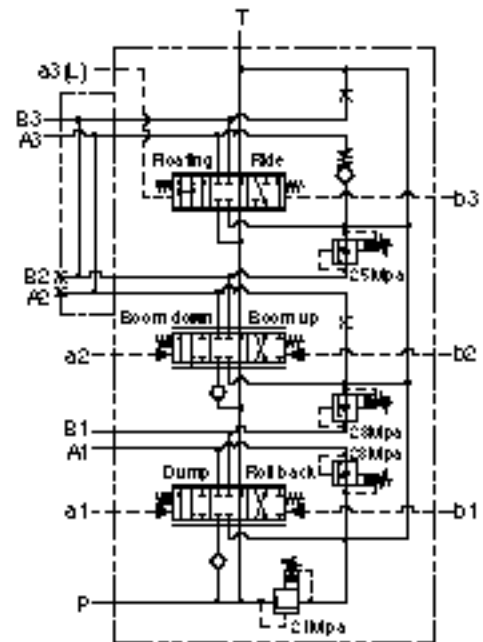
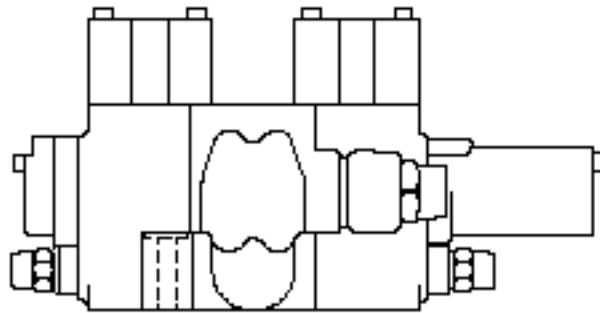
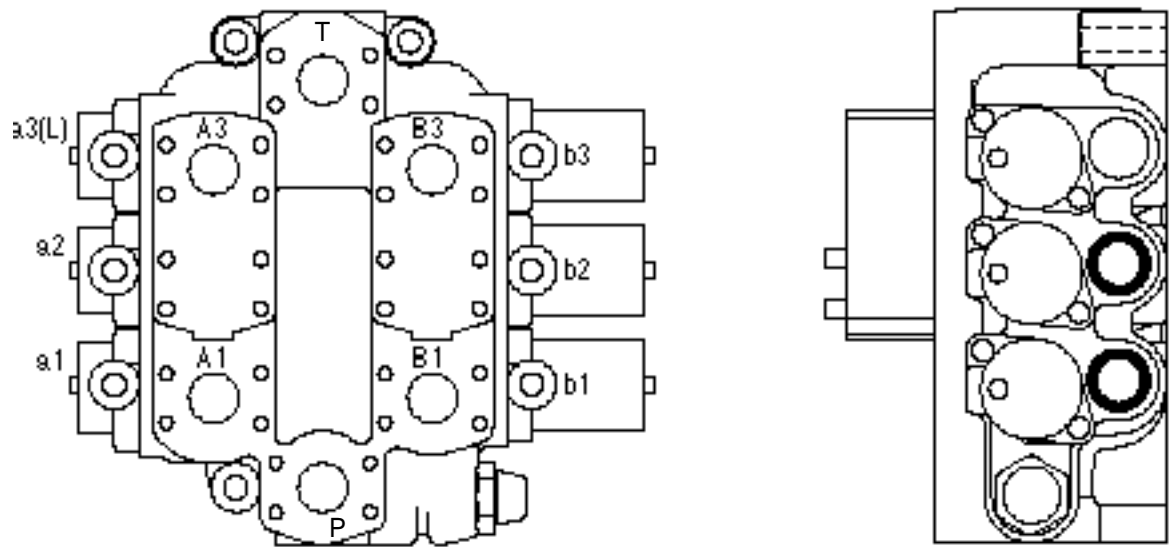

Port	Port name	Port size
P	From main pump	SAE 6000psi 3/4"
T	To hydraulic tank	SAE 6000psi 1"
A1, B1	To bucket cylinder port	SAE 6000psi 3/4"
A3, B3	To boom cylinder port	SAE 6000psi 3/4"
a1, b1	Bucket pilot port	PF 1/4
a2, a3, b2, b3	Boom pilot port	PF 1/4

2) BOOM SECTION OPERATION

(1) Spool in neutral

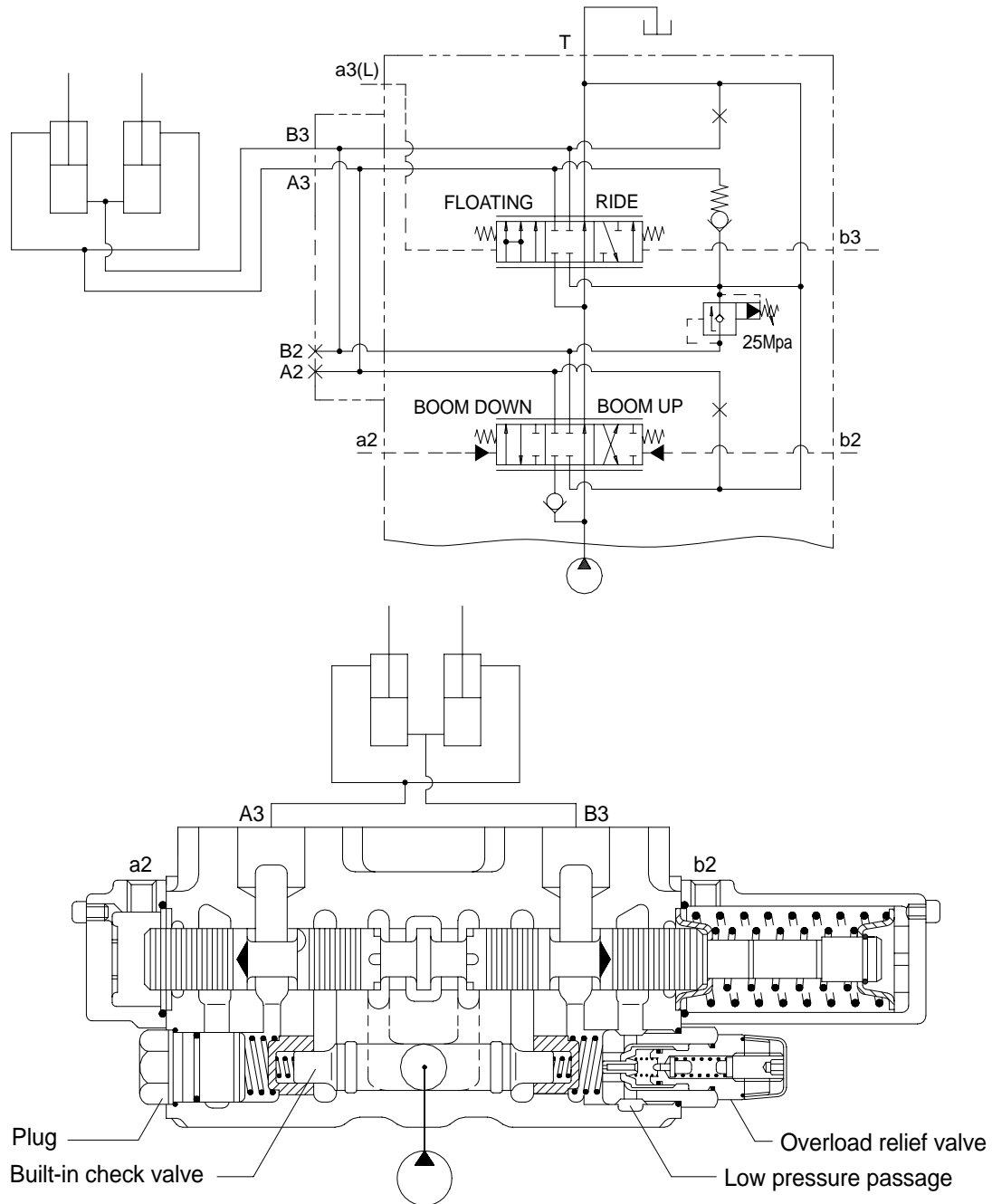

If the remote control valve is not operated, the oil supplied from the pump port passes through the neutral passage to the low pressure passage at the outlet section, and then returns to the tank port.

(2) Boom raise position

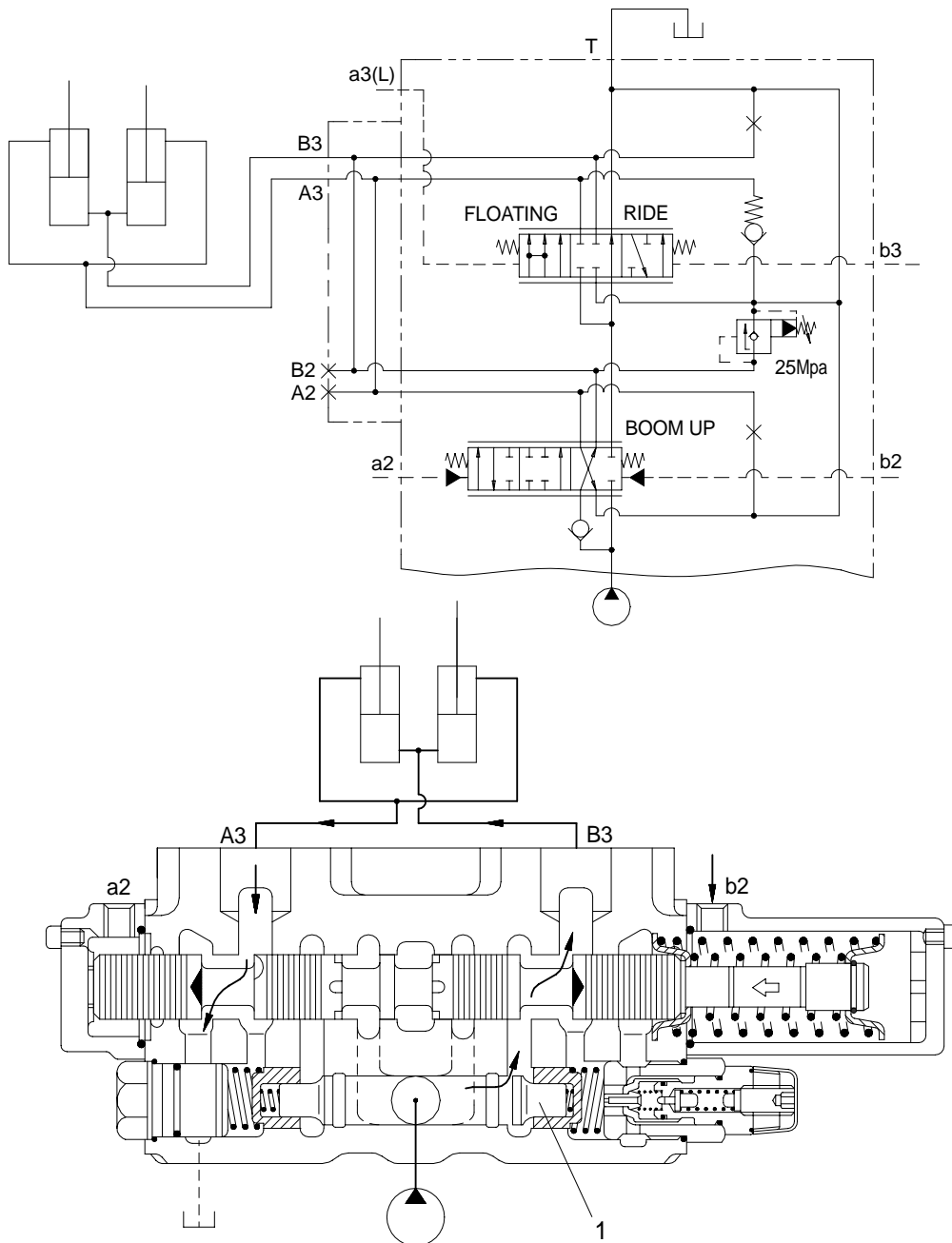

When the pilot pressure from remote control valve is supplied to the pilot port(b2), the spool moves to the left and the neutral passage is closed.

The oil supplied from the pump pushes up the load check valve(1) and flow into boom cylinder port(B3).

The pump pressure reaches proportionally the load of cylinder and fine control finished by shut off of the neutral passage.

The return oil from cylinder port(A3) flows into the tank via the low pressure passage.

(3) Boom lower position

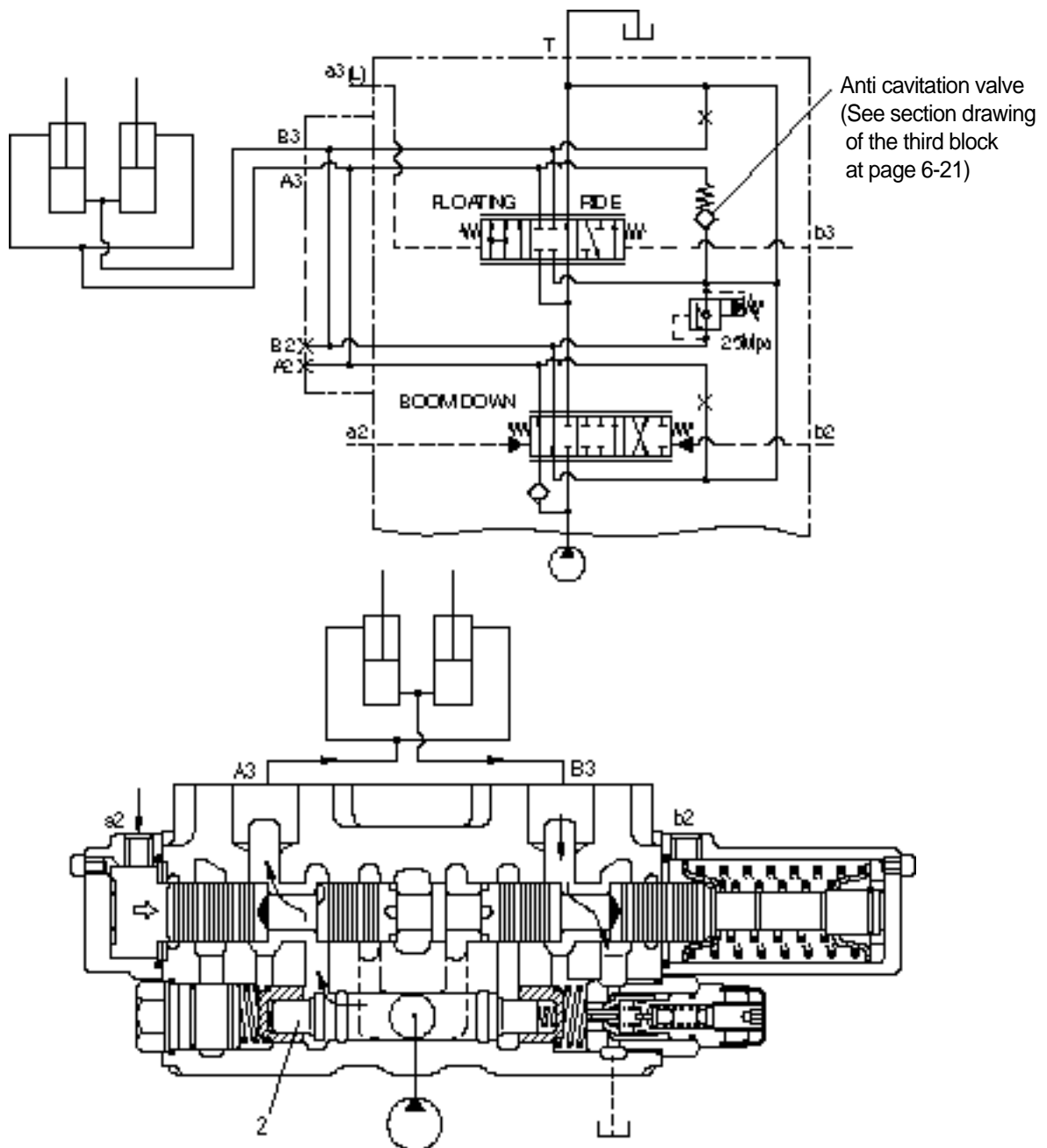

When the pilot pressure from remote control valve is supplied to the pilot port(a2), the spool moves to the right and the neutral passage is closed.

The oil supplied from the pump pushes up the load check valve(2) and flow into boom cylinder port(A3). The pump pressure reaches proportionally the load of cylinder and fine control finished by shut off of the neutral passage.

The return oil from cylinder port(B3) flows into the tank via the low pressure passage.

When the lowering speed of boom is faster, the return oil from the large chamber of boom cylinder combines with the oil from the pump through the anti cavitation valve, and flows into the small chamber of cylinder. This prevents cylinder cavitation by the negative pressure when the pump flow cannot match the boom lowering speed.

(4) Boom float position

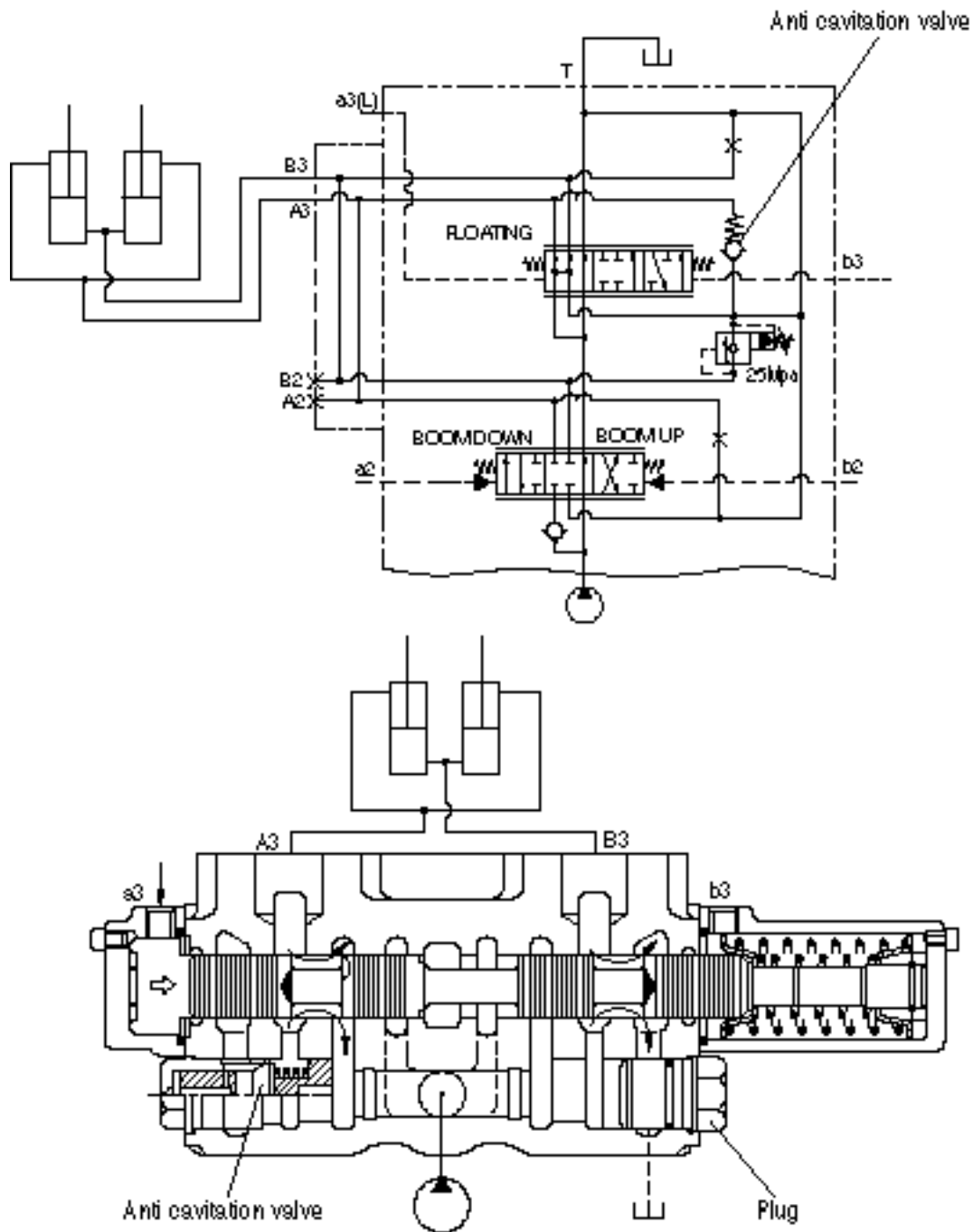

If the operator overrides the additional spring(7) in the RCV lower position, the pilot pressure from remote control valve rises further and then the boom float spool is pushed to the end position, opening up the neutral passage to tank and simultaneously(A3), (B3) → T.

Parallel the boom down spool will be released to neutral, because of moving spool in the remote control valve at 22bar(Refer to page 6-14).

In float position the boom drops quickly due to its own weight.

When the bucket touches the ground and the wheeled loader is moving, the bucket raised or lowered following the unevenness of the ground due to the (A3), (B3) → T connecting.

3) BUCKET SECTION OPERATION

(1) Spool in neutral

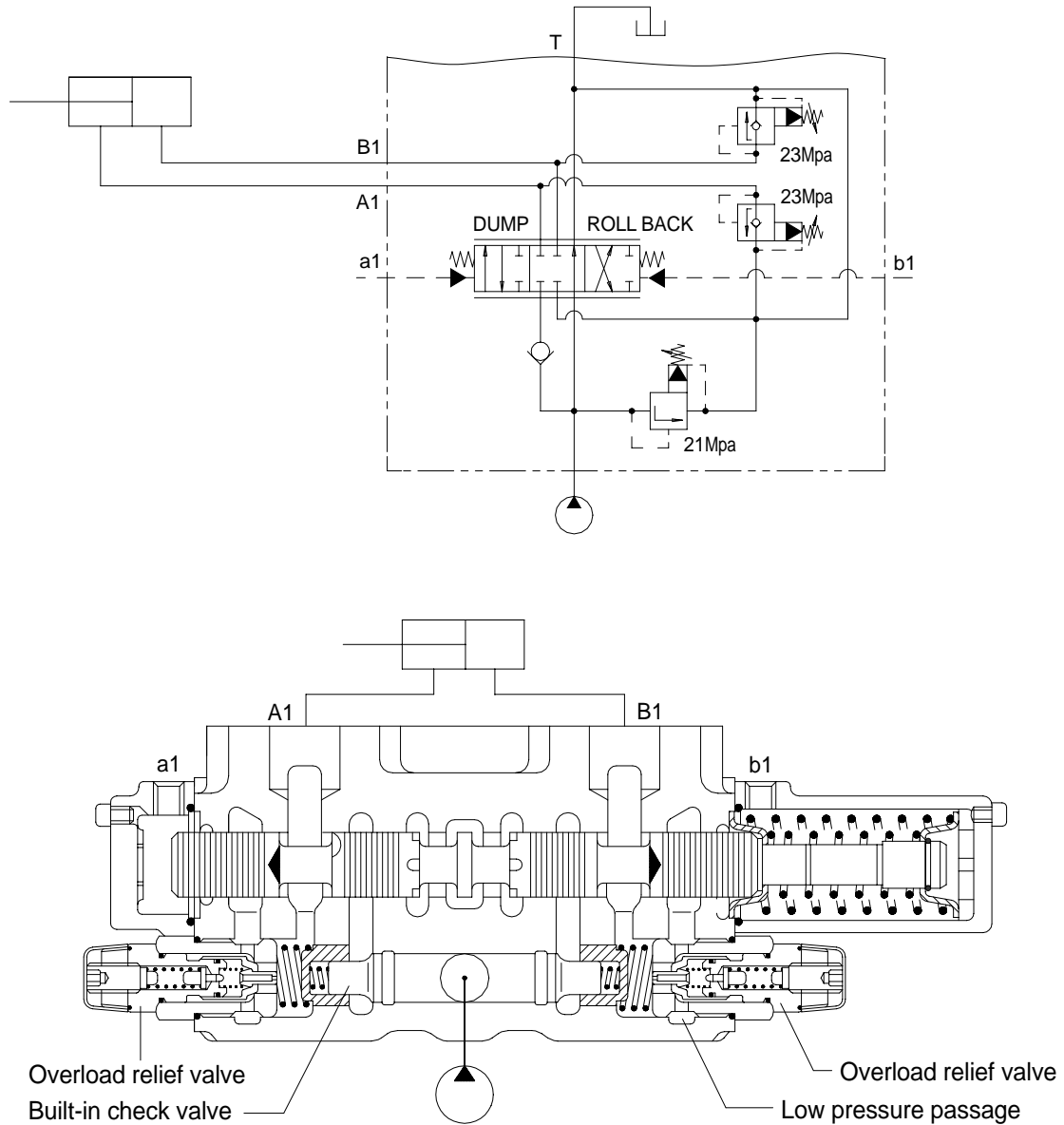

If the remote control valve is not operated, the oil supplied from the pump port passage through the neutral passage to the low pressure passage at the outlet section, and then return to the tank port.

(2) Retract(roll back) position

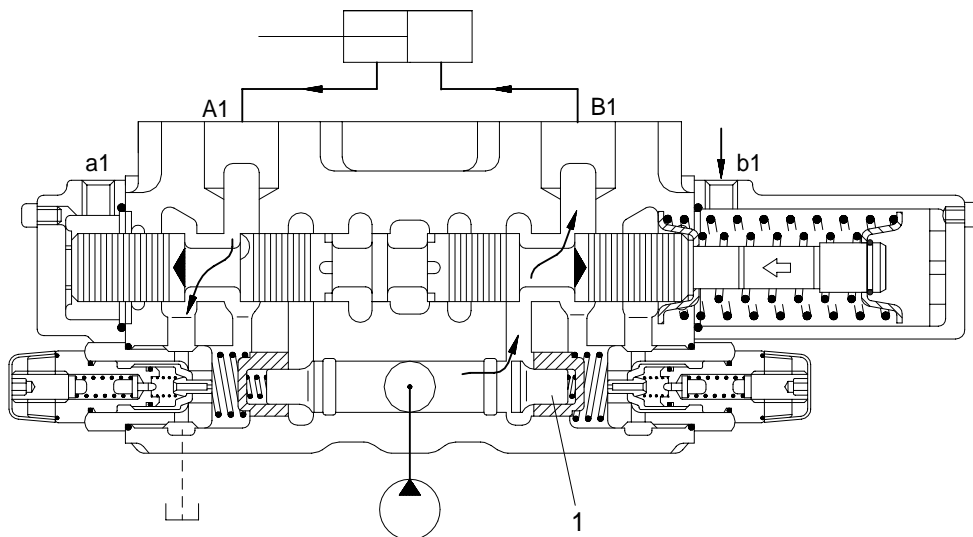
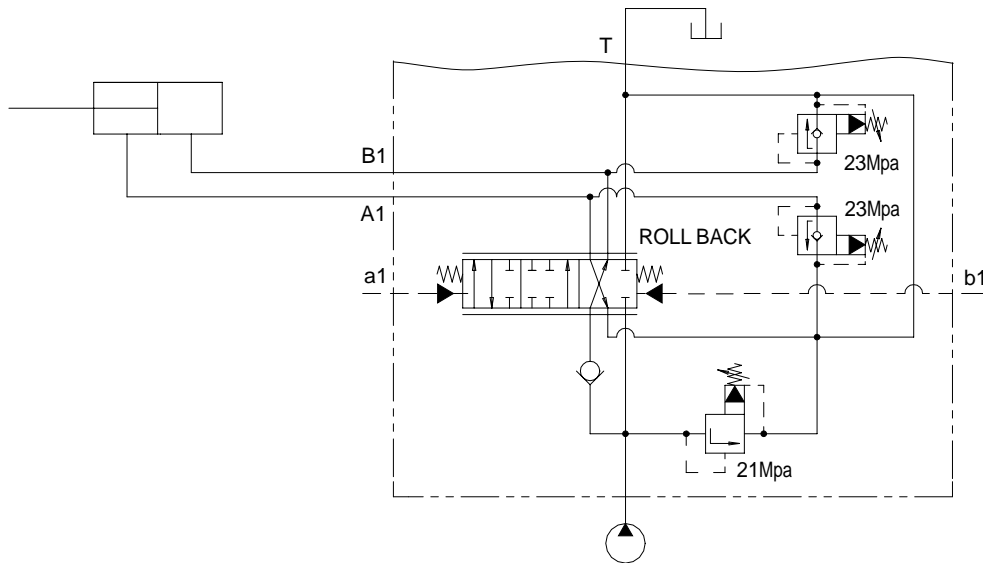

When the pilot pressure from remote control valve is supplied to the pilot port(b1), the spool moves to the left and the neutral passage is closed.

The oil supplied from the pump pushes up the load check valve(1) and flow into boom cylinder port(B1).

The pump pressure reaches proportionally the load of cylinder and fine control finished by shut off of the neutral passage.

The return oil from cylinder port(A1) flows into the tank via the low pressure passage.

(3) Dump position

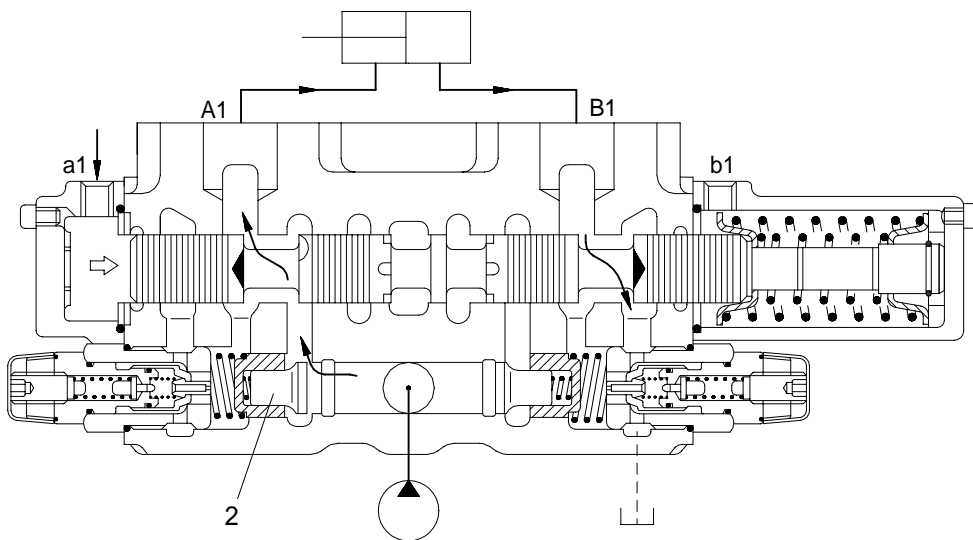
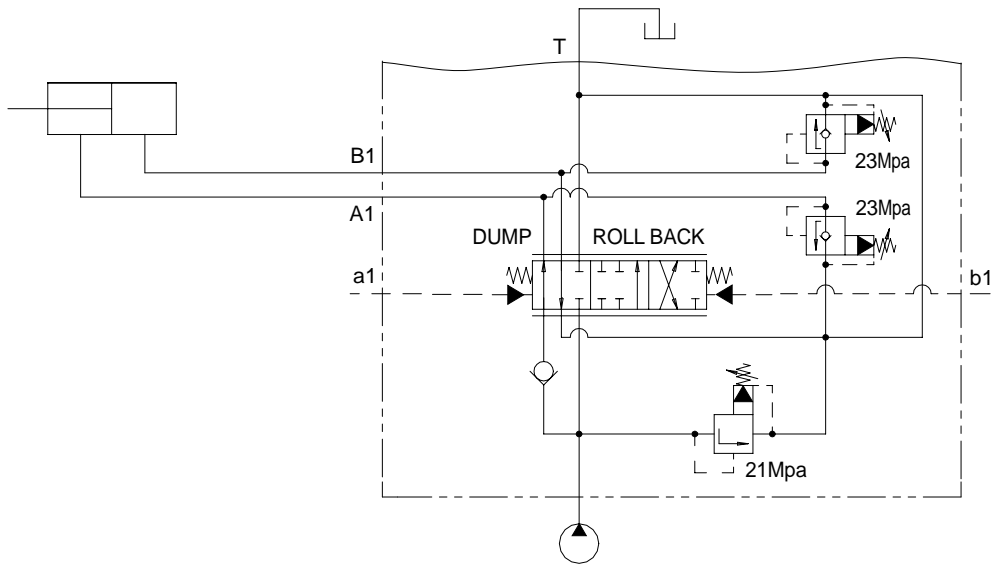

When the pilot pressure from remote control valve is supplied to the pilot port(a1), the spool moves to the right and the neutral passage is closed.

The oil supplied from the pump pushes up the load check valve(2) and flow into boom cylinder port(A1). The pump pressure reaches proportionally the load of cylinder and fine control finished by shut off of the neutral passage.

The return oil from cylinder port(B1) flows into the tank via the low pressure passage.

3) MAIN RELIEF VALVE

- The main relief valve is installed at the inlet of the main control valve. When the oil goes above the set pressure, the relief valve drains the oil to the tank. In this way, it sets the maximum pressure in the hydraulic circuit and protects the circuit.
- The valve poppet(C) is connected via the throttle drillings(D1) and (D2) with the P port. If static pressure increases above the set pressure value, the valve poppet(C) opens and allows oil to flow freely to tank(Y). This oil generates a pressure drop in the spring chamber of the main poppet, the closing force of the spring(Z) is cancelled, and the main poppet(A) opens to allow the pump flow to flow to tank(T). Damped opening and closing is obtained by the throttled volumetric change.
- The set pressure can be varied by changing the tension of pressure spring(F). To change the set pressure, remove cap nut, loosen lock nut and turn adjustments screw(E) and follows.

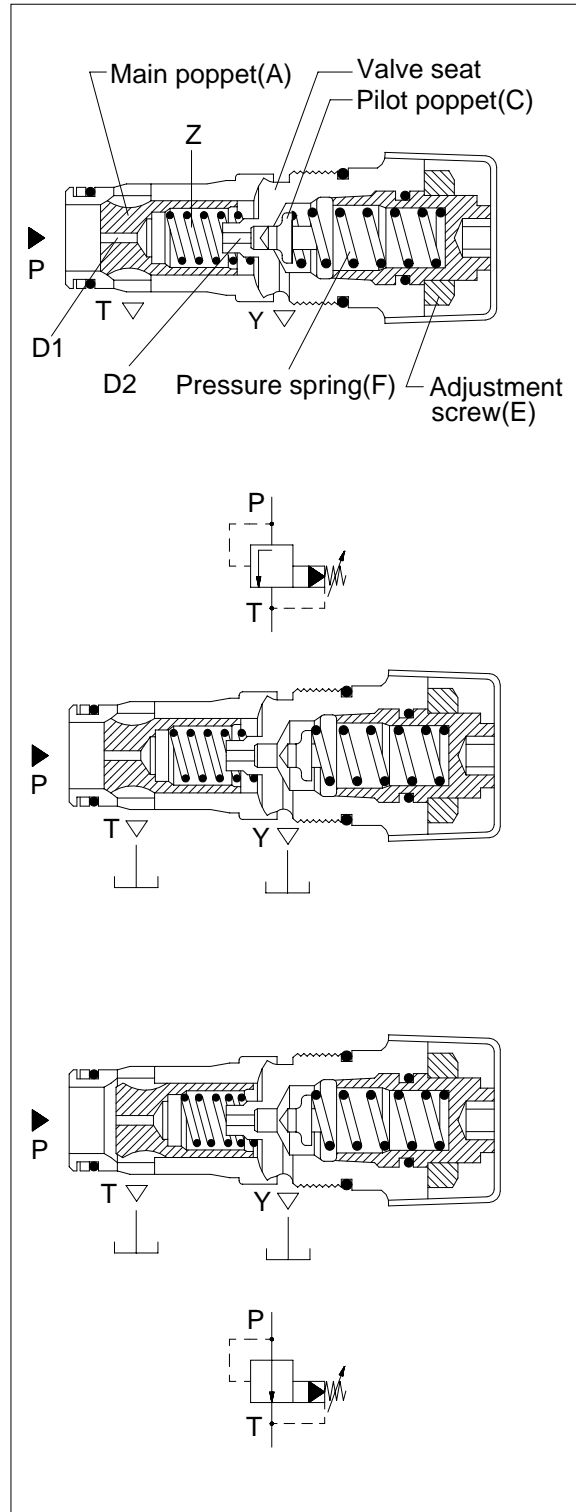

4) OVERLOAD RELIEF VALVE

- The overload relief valve (Combined relief/ anticavitation valve) is in the boom cylinder and bucket cylinder circuit in the main control valve.

If shock causes any abnormally high pressure in the cylinder when the main valves is at neutral, the overload relief valve releases the abnormal pressure and protects the cylinder from damage.

- During normal operation, the poppet(2) is positioned against the body(1) to seal the workport(A) oil from the return(T) passage.
- As the circuit pressure approach the relief pressure setting, the pressure forces the pilot poppet(3) off its seat and allows oil to flow freely via the annular passage to tank. This oil generates a pressure drop in the spring chamber of the main poppet(2), the closing force of the spring(4) is cancelled. The main poppet(2) opens to allow flow from P to T.
- If cavitation in the workport occurs, the oil pressure in the workport drop below return pressure. Tank line return pressure oil works against the shoulder(A3) of the poppet to force it open against the spring and the workport pressure at (A2)-(A1).

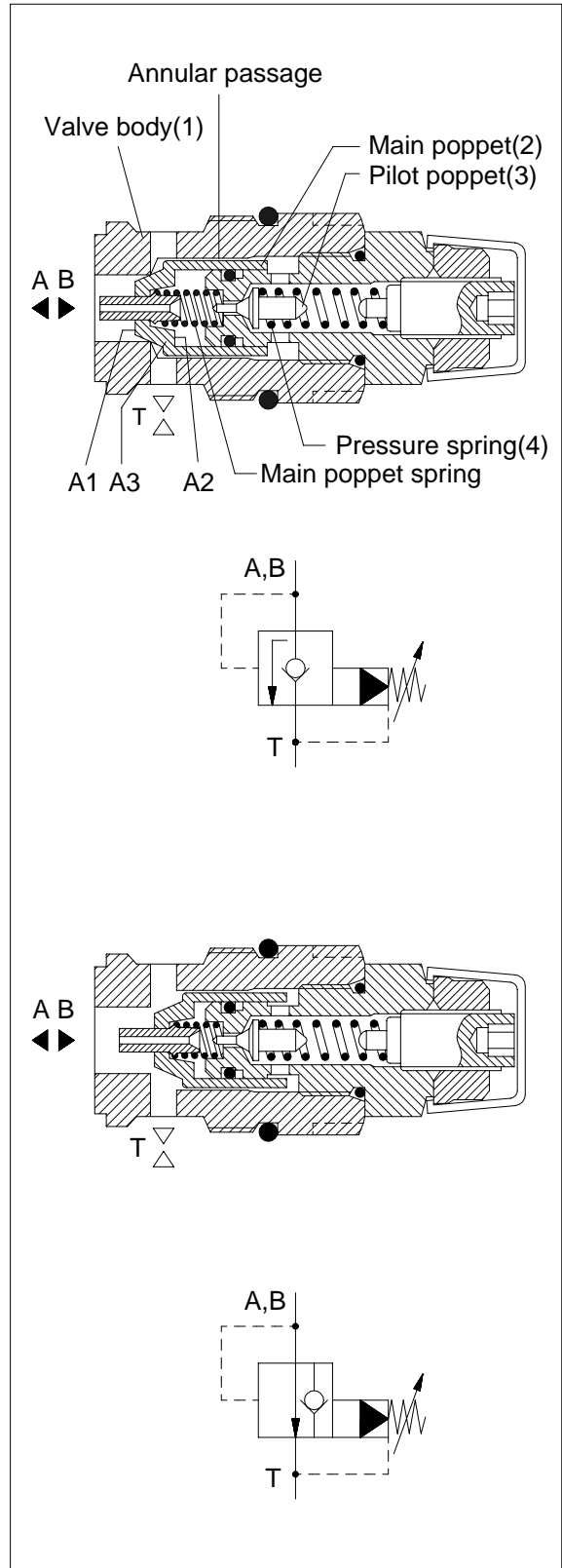

6. PILOT OIL SUPPLY UNIT

1) STRUCTURE

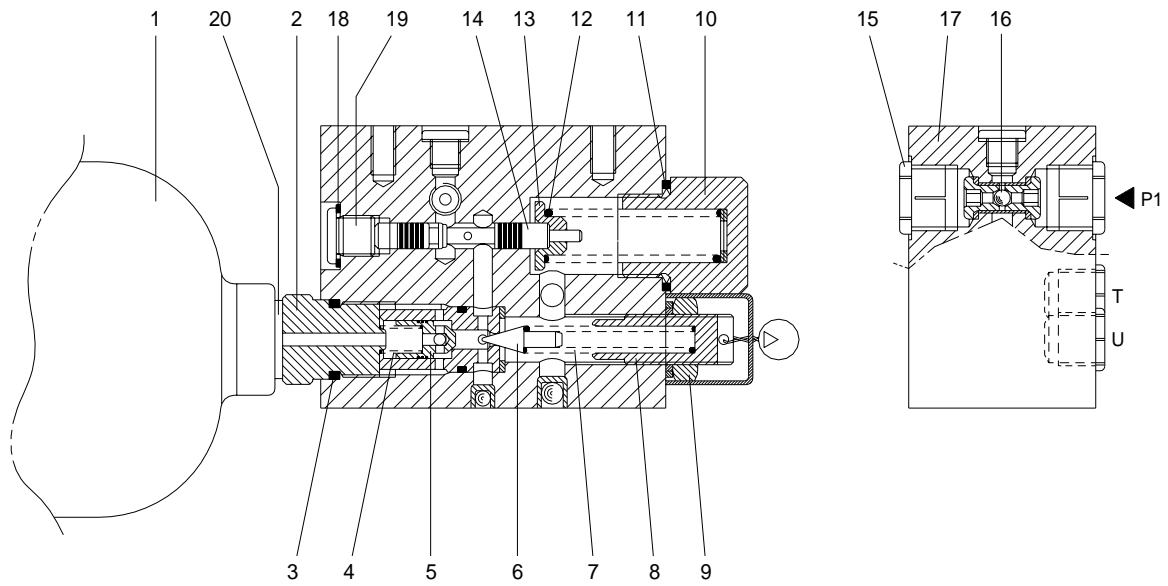

Port	Size
P1, P2	3/4" UNF
U, T	9/16" UND

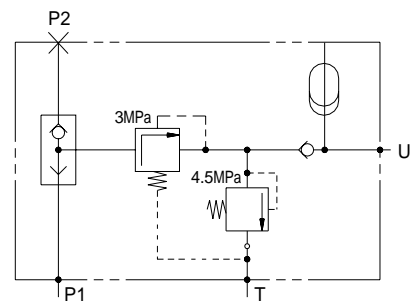

CIRCUIT DIAGRAM

- | | | | | | |
|---|-------------|----|-----------------|----|---------------|
| 1 | Accumulator | 8 | Plug | 15 | Plug |
| 2 | Connector | 9 | Nut | 16 | Shuttle valve |
| 3 | O-ring | 10 | Plug | 17 | Housing |
| 4 | Spring | 11 | Seal | 18 | O-ring |
| 5 | Valve | 12 | Spring | 19 | Plug |
| 6 | Valve | 13 | Spring retainer | 20 | Washer |
| 7 | Spring | 14 | Spool | | |

(2) OPERATION

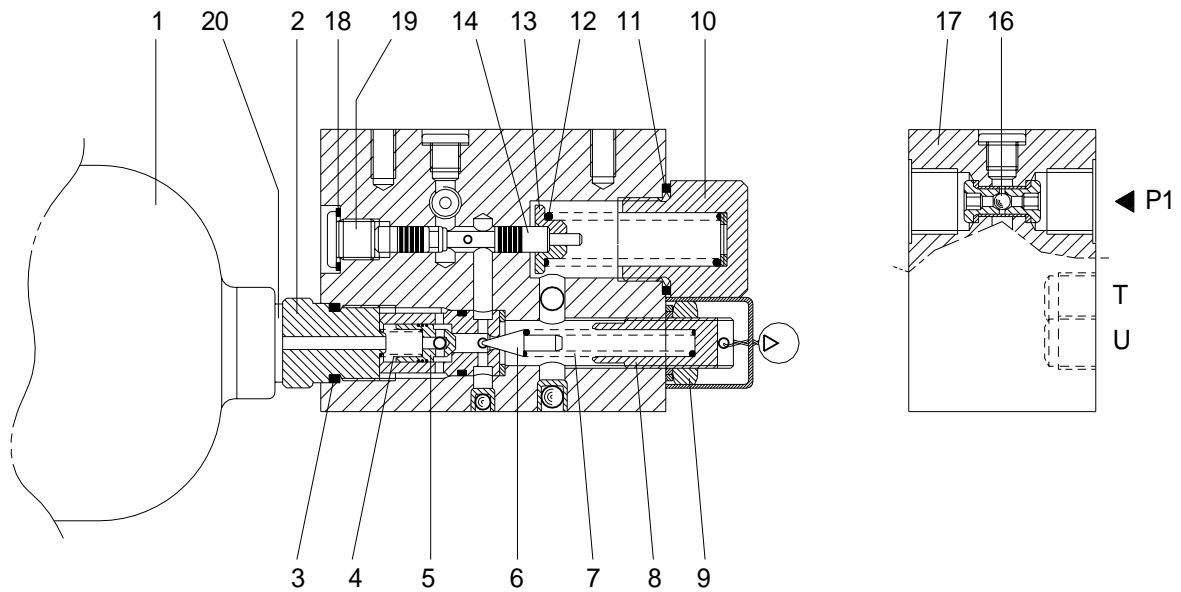

Pilot oil supply units are a combination of valves which reduce the pressure of medium and high pressure circuits in order to supply remote control valves with a low pressure supply of oil. They basically consist of the accumulator(1), the housing(17), a shuttle valve(16), a direct operated pressure relief valve(6) and a check valve(5).

Fluid flows from the high pressure via the shuttle valve(16) through port P1 into the unit and then to the secondary circuit. The pressure is reduced to the required level by means of spool(14) and passes via the check valve(5) into the accumulator(1) thus ensuring through port U greater control power and when necessary-emergency operation should the main circuit be switched off or become defective.

Pressure relief valve(6) protects the pilot circuit should the spool(14) fail to operate. Check valve(5) prevents the accumulator emptying into the primary circuit.

Accumulator satisfies short term peak power demands and is a source of emergency power should the main circuit pressure fail.

7. SAFETY VALVE UNIT

1) STRUCTURE

The safety valve locks or permits pilot oil flow to the main control valve operation.

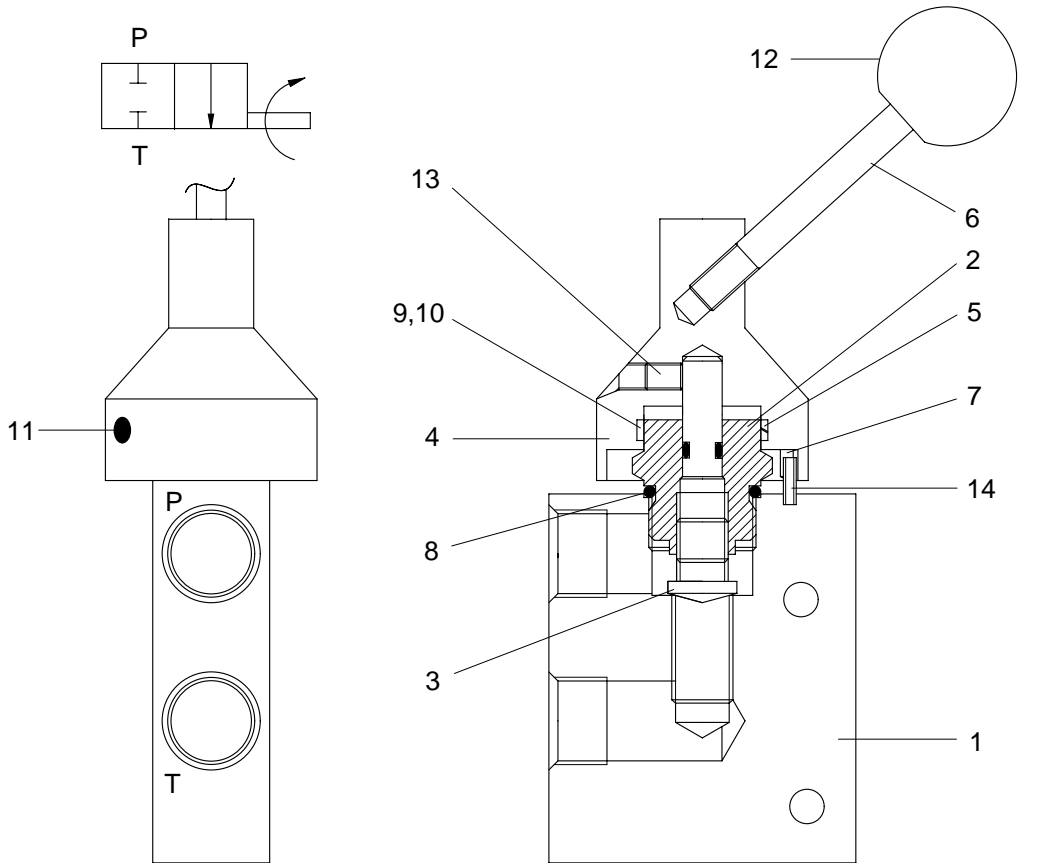

- | | | | | | |
|---|-------------|----|--------------|----|------------------|
| 1 | Body | 6 | Handle | 11 | Spring plunger |
| 2 | Retainer | 7 | Spring ring | 12 | Knob |
| 3 | Adjust stem | 8 | O-ring | 13 | Socket set screw |
| 4 | Housing | 9 | O-ring | 14 | Spring pin |
| 5 | Clutch ring | 10 | Back up ring | | |

8. BOOM AND BUCKET CYLINDER

The boom cylinders are two unit and the bucket cylinder is one unit. They use a bolt on rod guide.

The piston(12) threads on to the rod(2) and is retained by a nut(17) and set screw(18).

The piston seals against the tube(1) with piston seal(14). Two wear rings(15) are located on each side of the piston seal.

The gland(3, the rod guide) seals against the tube with an O-ring(10). The cylinder thread seals against the rod with a lip type buffer ring(7) and a rod seal(5). A dust wiper(8) cleans the rod when it is retracted.

1) BOOM CYLINDER

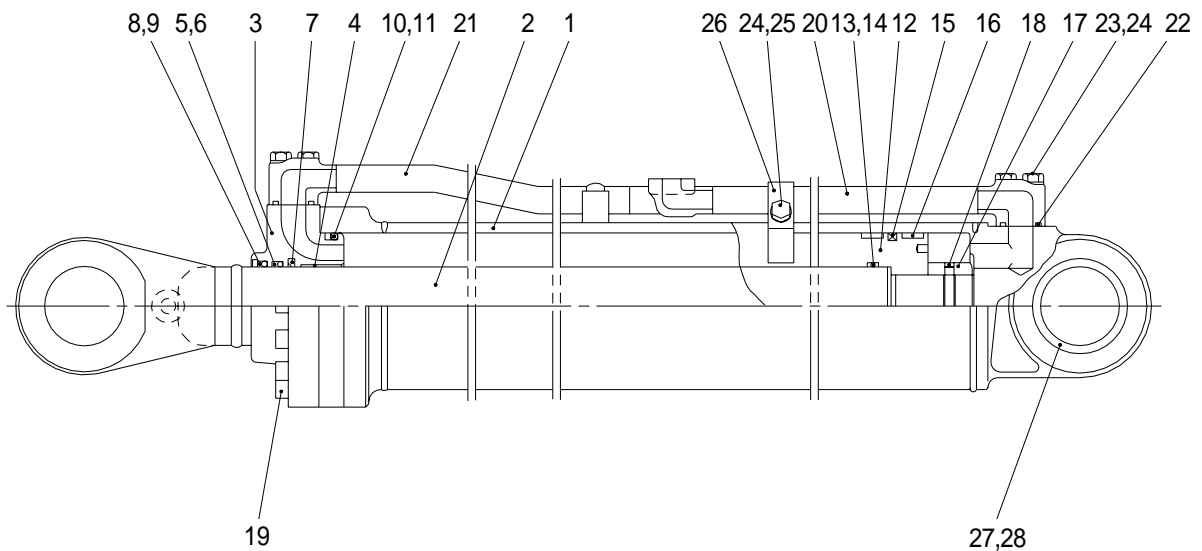

1	Tube assy	11	Back up ring	21	Pipe assy
2	Rod assy	12	Piston	22	O-ring
3	Gland	13	O-ring	23	Bolt
4	Bushing	14	Back up ring	24	Spring washer
5	Rod seal	15	Piston seal	25	Bolt
6	Back up ring	16	Wear ring	26	Band
7	Buffer ring	17	Piston nut	27	Bushing
8	Dust wiper	18	Screw	28	Dust seal
9	Snap ring	19	Bolt		
10	O-ring	20	Pipe assy		

2) BUCKET CYLINDER

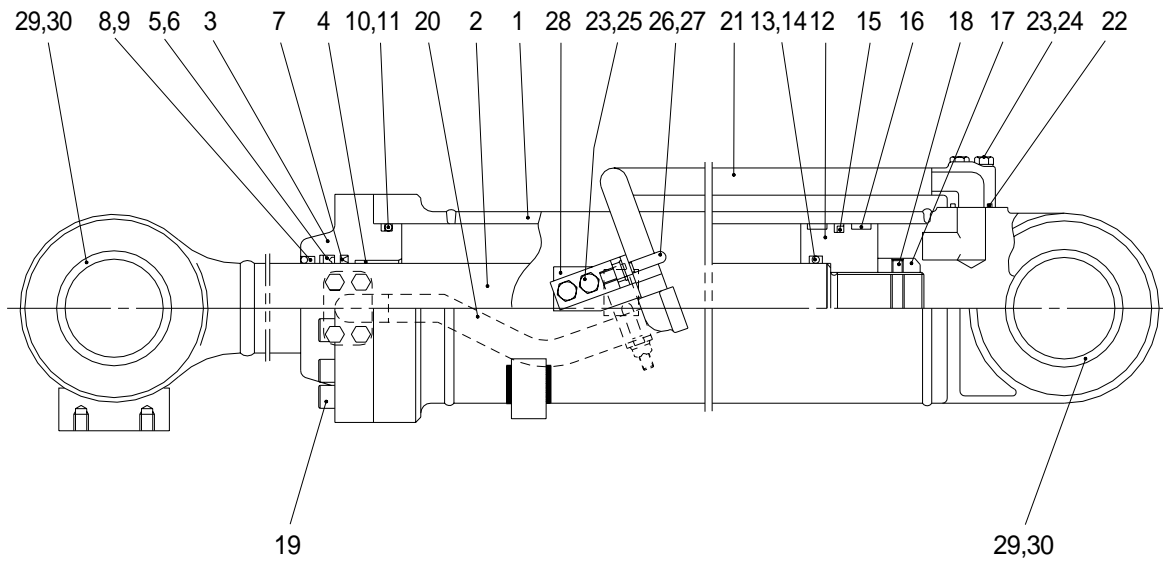

1	Tube assy	11	Back up ring	21	Pipe assy
2	Rod assy	12	Piston	22	O-ring
3	Gland	13	O-ring	23	Bolt
4	Bushing	14	Back up ring	24	Spring washer
5	Rod seal	15	Piston seal	25	Bolt
6	Back up ring	16	Wear ring	26	U-bolt
7	Buffer ring	17	Piston nut	27	Nut
8	Dust wiper	18	Screw	28	Bracket
9	Snap ring	19	Bolt	29	Bushing
10	O-ring	20	Pipe assy	30	Dust seal

9. HYDRAULIC OIL TANK

1) STRUCTURE

- The oil from the hydraulic tank is sent from the pump through control valve to the cylinders. In the return circuit, the oil from various parts merges.
- A part of oil is cooled in the oil cooler, passes through the hydraulic filter and returns to the hydraulic tank(1).
- If the hydraulic return oil filter becomes clogged, return filter bypass valve(3) acts to allow the oil to return directly to the hydraulic tank(1). This prevents damage to the hydraulic filter(2). The bypass valve(3) is also actuated when negative pressure is generated in the circuit.

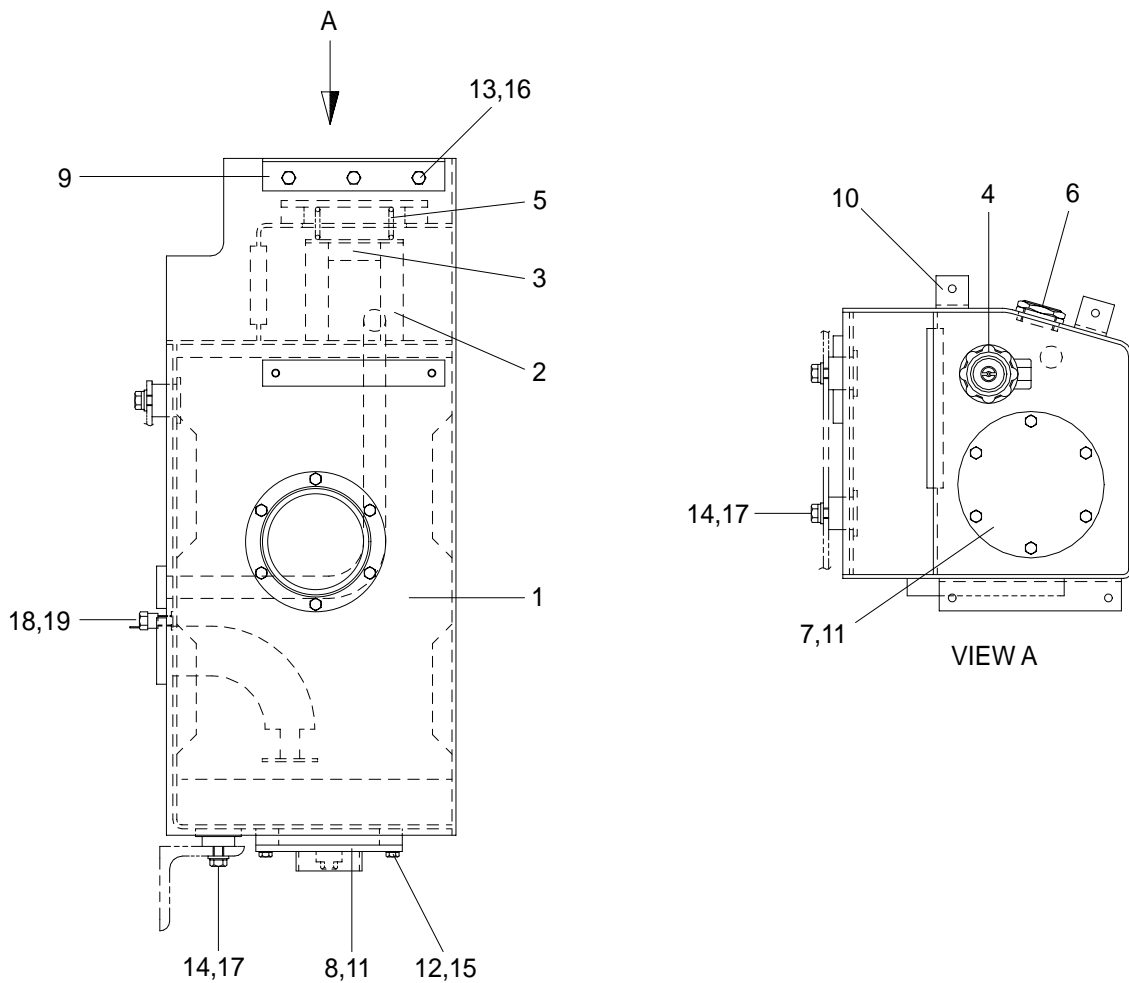

1	Hydraulic tank	8	Cover	15	Spring washer
2	Element	9	Plate	16	Hardened washer
3	Bypass valve	10	Plate	17	Hardened washer
4	Air breather	11	O-ring	18	Overheat switch
5	Spring	12	Bolt	19	O-ring
6	Sight gauge	13	Bolt		
7	Cover	14	Bolt		

2) RETURN OIL FILTER BYPASS VALVE

(1) When the filter is clogged

Bypass valve(1) is opened and the oil returns directly to the tank without passing through the filter.

Bypass valve set pressure : 1.36kg/cm²
(19.3psi)

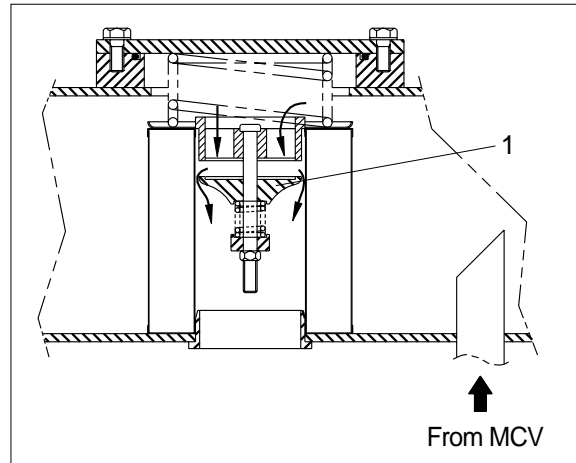

3) AIR BREATHER

The air breather is equipped with the capacity to perform three functions simultaneously-as an air filter, breathing valve, and as a lubrication opening.

(1) Preventing negative pressure inside the tank

The tank is a pressurized sealed type, so negative pressure is formed inside the hydraulic tank when the oil level drops during operations. When this happens, the difference in pressure between the tank and the outside atmospheric pressure opens the poppet in the breather, and air from the outside is let into the tank or prevent negative pressure.

(2) Preventing excessive pressure inside the tank

When the hydraulic cylinder is being used, the oil level in the hydraulic system increases and as temperature rises. If the hydraulic pressure rises above the set pressure, breather is actuated to release the hydraulic pressure inside the tank.

(3) Specification

Description		Spec
Exhaust side setting pressure		0.5kg/cm ² (7.1 psi)
Intake side setting pressure		0.05kg/cm ² (0.7psi)
Filtration rating	Element	10μm
	Strainer	40μm

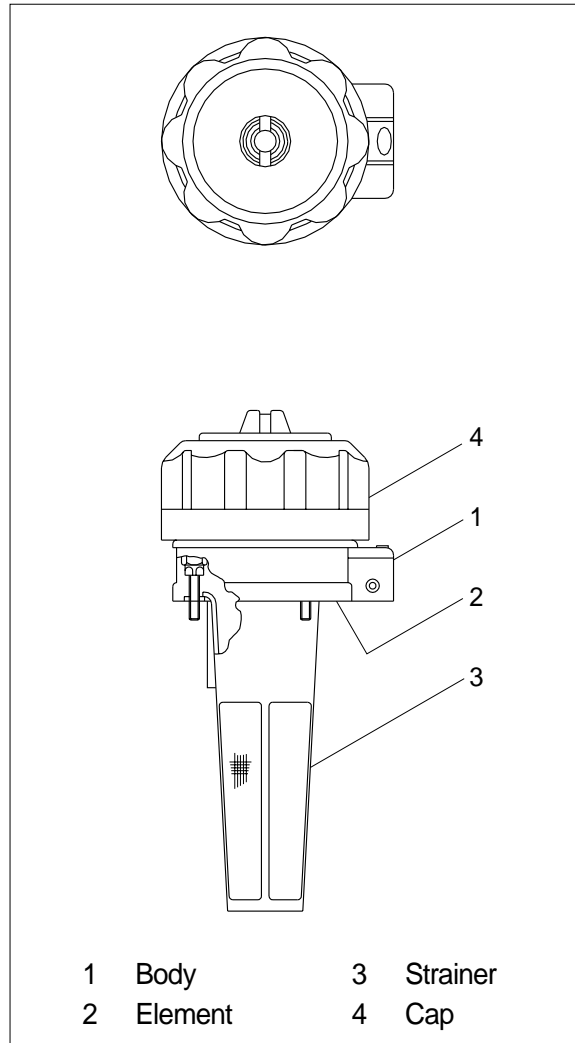

10. ACCUMULATOR

The accumulator is installed at the pilot oil supply unit. When the boom is left the raised position, and the control levers are operated with the engine stopped the pressure of the compressed nitrogen gas inside the accumulator sends pilot pressure to the control valve to actuate it and allow the boom and bucket to come down under their own weight.

Type of gas	Nitrogen gas(N ₂)
Volume of gas	0.75 l (0.2 U.S.gal)
Charging pressure of gas	16kg/cm ² (228psi)
Max actuating pressure	30kg/cm ² (427psi)

