

GROUP 4 DISASSEMBLY AND ASSEMBLY

1. MAIN PUMP

1) STRUCTURE

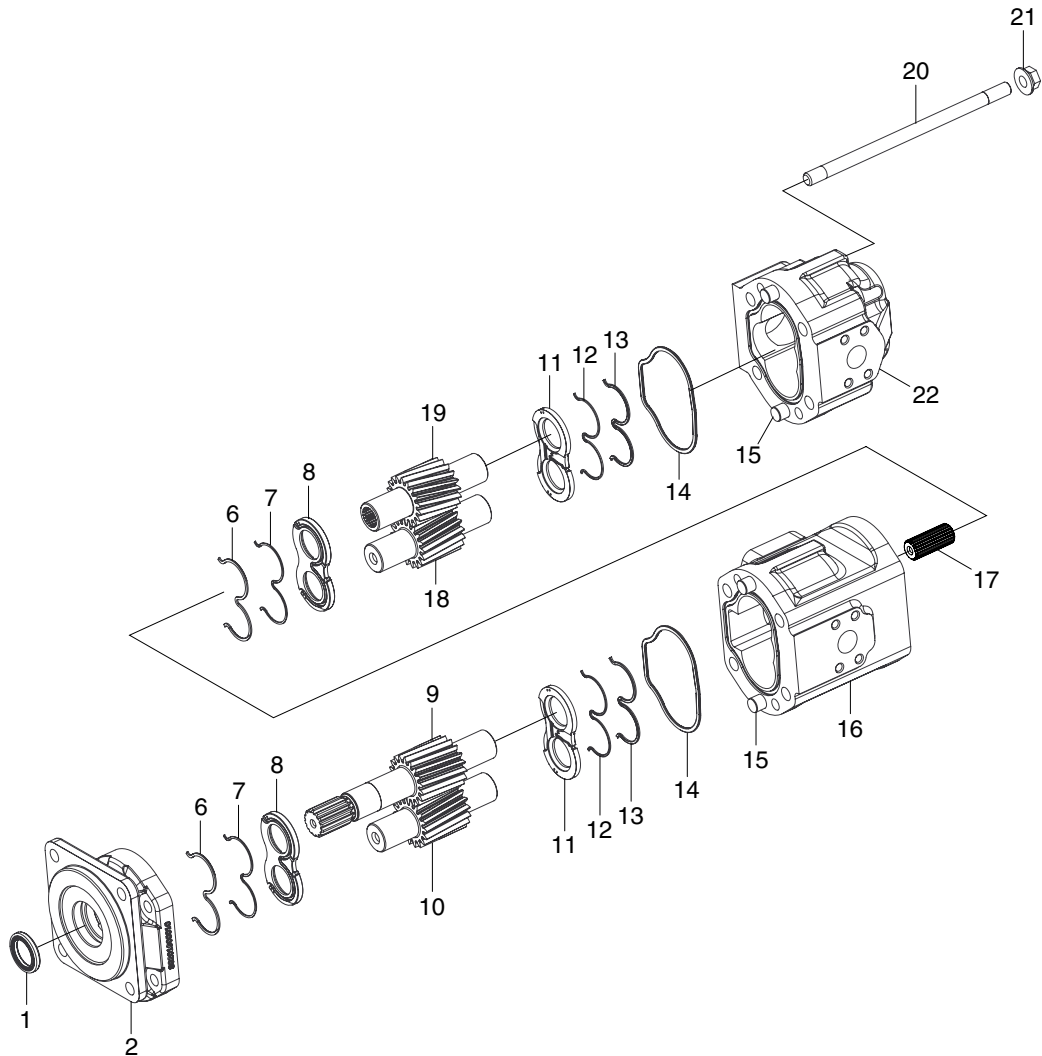

7407WE12

- | | | | | | |
|----|-------------------|----|----------------|----|------------------|
| 1 | Shaft seal | 11 | Wearplate | 17 | Spline coupling |
| 2 | Adapter | 12 | O-ring seal | 18 | Rear driven gear |
| 6 | Back up seal | 13 | Back up seal | 19 | Rear drive gear |
| 7 | O-ring seal | 14 | Interface seal | 20 | Stud |
| 8 | Wearplate | 15 | Dowel | 21 | Flanged nut |
| 9 | Front drive gear | 16 | Front body | 22 | Rear body |
| 10 | Front driven gear | | | | |

2) DISASSEMBLY

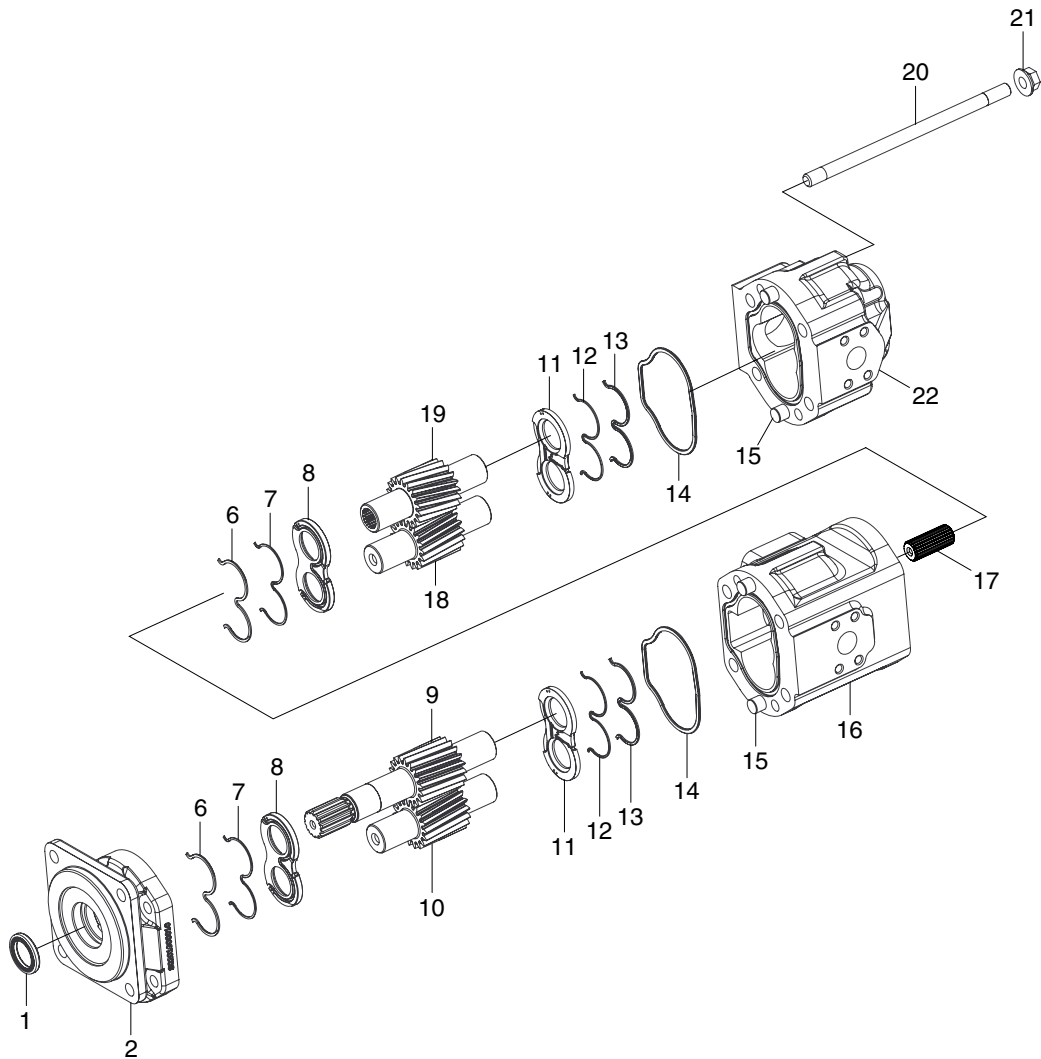

7407WE12

- ※ Plug all ports prior to cleaning and disassembling pump to prevent ingress of debris or contamination.
 - ※ Clean the pump thoroughly with a solvent, ensuring no loose debris or contamination remains on the unit.
 - ※ Mark each interface and then separate into individual pump sections.
- (1) Securely clamp pump horizontally on one port face, ensuring that no damage is sustained to the port face and remove the stud(20) and nut(21).
 - (2) Remove the front adaptor(2) from the body(16) using a pulling tool centred on the drive shaft(9).
- ※ Under **NO** circumstances attempt to prise or chisel cover from body as such action could damage the machined sealing faces.
- (3) Remove and discard the shaft seal(1) from adaptor making sure that no damage is sustained to the surface of the seal bore.
 - (4) Unclamp pump and place it vertically with drive shaft up.
 - (5) Before removing wearplate from the body mark it using a soft pencil or a felt-tip pen to ensure correct reassembly. Remove wearplate(8) complete with O-ring seal(7) and back up seal(6).

DISASSEMBLY

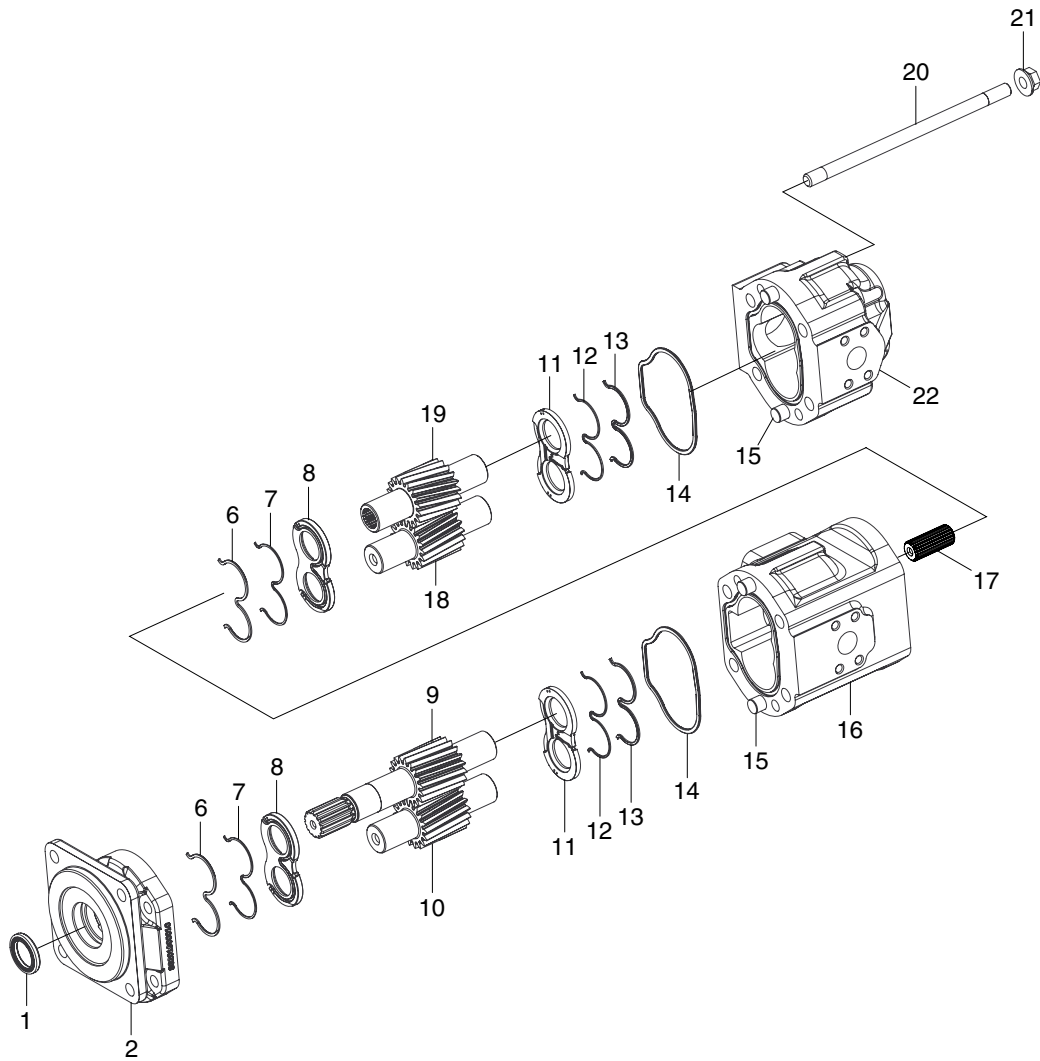

7407WE12

- (6) Mark the gears using a soft pencil or felt-tip pen to ensure assembly in the same relative position, see figure on the right, then withdraw the drive shaft/gear(9) and driven gear(10) separately to prevent jamming.
- (7) Again, to ensure correct assembly, mark remaining wearplate(11) using a soft pencil or a felt-tip pen. Remove wearplate from body complete with O-ring seal(12) and back up seal(13).
- (8) Discard interface seal(14).
- (9) Having separated into individual pumps, proceed as per paragraph (1)~(7).



7607WE34

3) MANDATORY REPLACEMENT PARTS

Discard all seals including interface seals, shaft seals, wear plate seals and back up seals. Fit new seals on reassembly. Wearplates should also be replaced with new items from seal kit.

4) HANDLING/STORAGE

While disassembling pump, ensure no surfaces are scored or marked in any way. A rubber surfaced table will be beneficial. All components must be placed in a clean, dry and safe area. Leakage will be created by scratches on components. If parts are to be left for any period ensure they are not exposed to dirt, dust and corrosion. Keep gears separate from each other in protective boxes.

5) INSPECTION OF PARTS

Wash all parts in a solvent and dry.

(1) Adaptor housing and cover

The pump must be replaced if the damage listed is present.

Feature	Damage
Surfaces	Corrosion, nicks or burrs(slight burrs can be removed using and india stone)
Machined sealing interfaces	Scores, cracks or corrosion
Bearing	Loose

(2) Gears

The pump must be replaced if the damage listed is present.

Feature	Damage
Surfaces	Corrosion, nicks or burrs(slight burrs can be removed using an India stone). Wear due to seal(s)
Journals	Pitting, wear, sufficient wear to change outside diameter
Tooth	Cracks or heavy scoring or chipped
Splines/keyways	Distortion of wear
End faces	Wear, cracks

(3) Floating wear plates

The pump must be replaced if the damage listed is present.

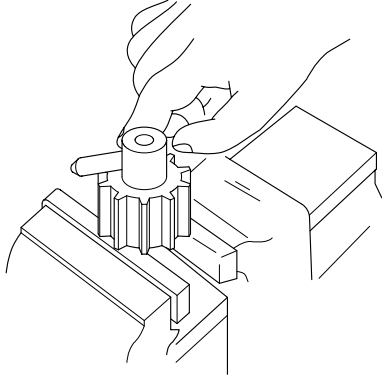
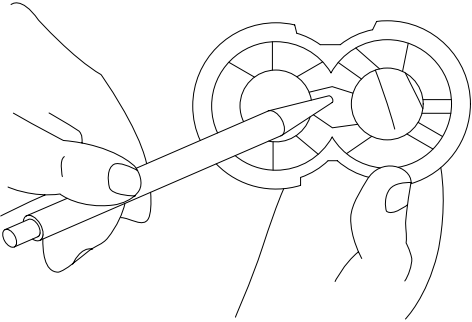
Feature	Damage
Surfaces	Corrosion, nicks or burrs, amounts of scoring, erosion or any cracks, discoloration caused by overheating
 <p>Removing burrs or minor scoring from end faces and teeth of the gears.</p>	 <p>Scoring of wear plate.</p>

(4) Bolts/Studs

The pump should be replaced if the damage listed is present.

Feature	Damage
Surfaces	Corrosion, nicks or burrs (slight burrs can be removed using an India stone), cracks or scoring, distortion or damage to thread form

(5) Plain bearings

The pump must be replaced if the damage listed is present.

Feature	Damage
Surfaces	Cracks or scoring
PTEF Coating	Worn-bronze, sub-layer showing
Bearing	Loose in housing/cover

(6) Coupling

This must be replaced if damage listed is present.

Feature	Damage
Surfaces	Corrosion, nicks or burrs, erosion, cracks or pitting
Splines	Distorted or badly worn

6) ASSEMBLY

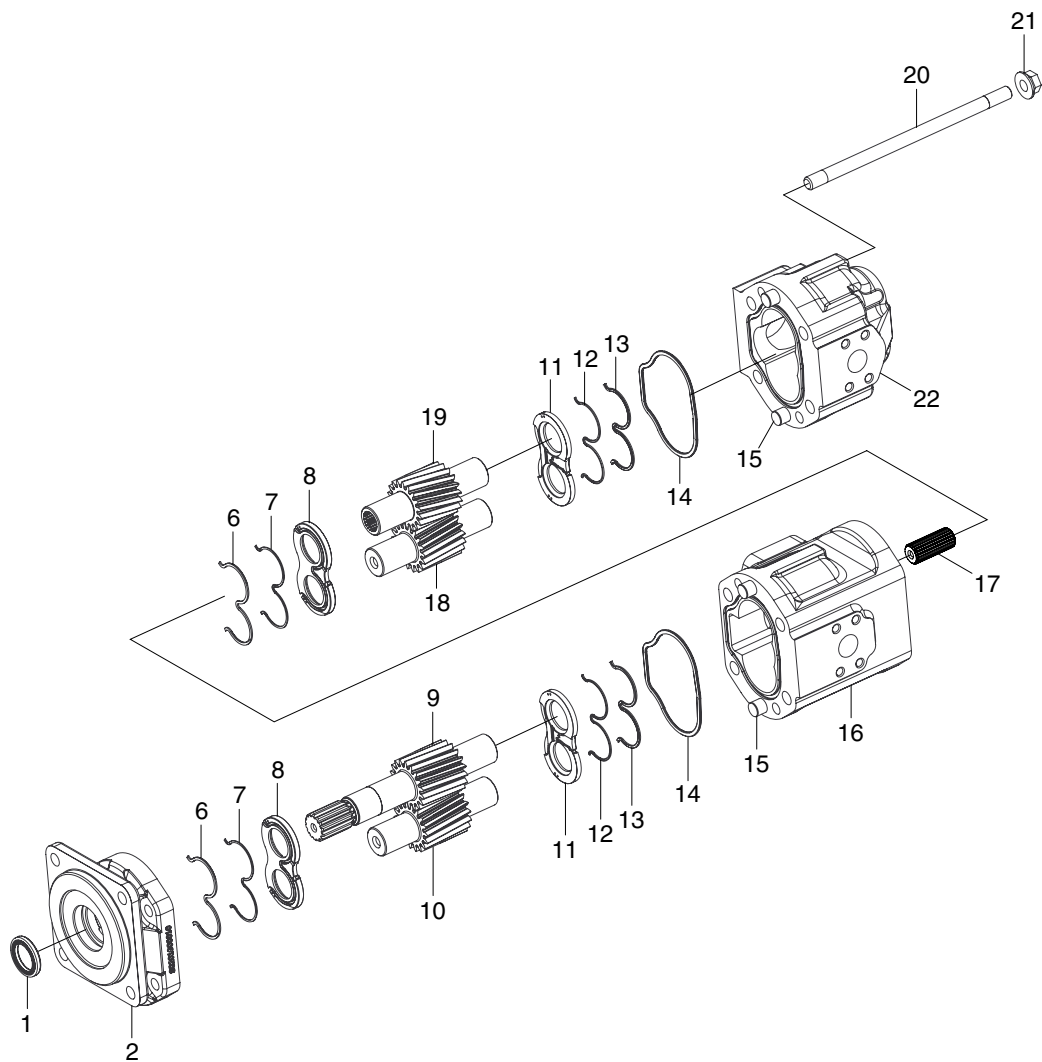

7407WE12

- ※ It is critical that the wearplates are assembled into the pump with regard to the following:
 - The seal side of the wearplate must be adjacent to the adaptor or body.
 - The high pressure side of the wearplate must be adjacent to the outlet port.
- ※ This must take place in a clean dry area, ensuring that all parts are clean and free from contamination or loose particles. Lightly oil all surfaces.
- (1) Place body vertically with gear pockets upper most.
- (2) Slide wearplate(11) complete with O-ring seal(12) and back up seal(13) down through the housing to the bottom of the gear pockets.
- ※ Be sure to refit the wearplate the same as that marked from this position during disassembly.
- (3) Fit the gears(18,19) within the housing taking care to replace as marked, with the teeth reassembled to their original related position.
- (4) Fit the wearplate(8) complete with O-ring seal(7) and back up seal(6).
- ※ Be sure to refit the wearplate the same as that marked from this position during disassembly.

ASSEMBLY

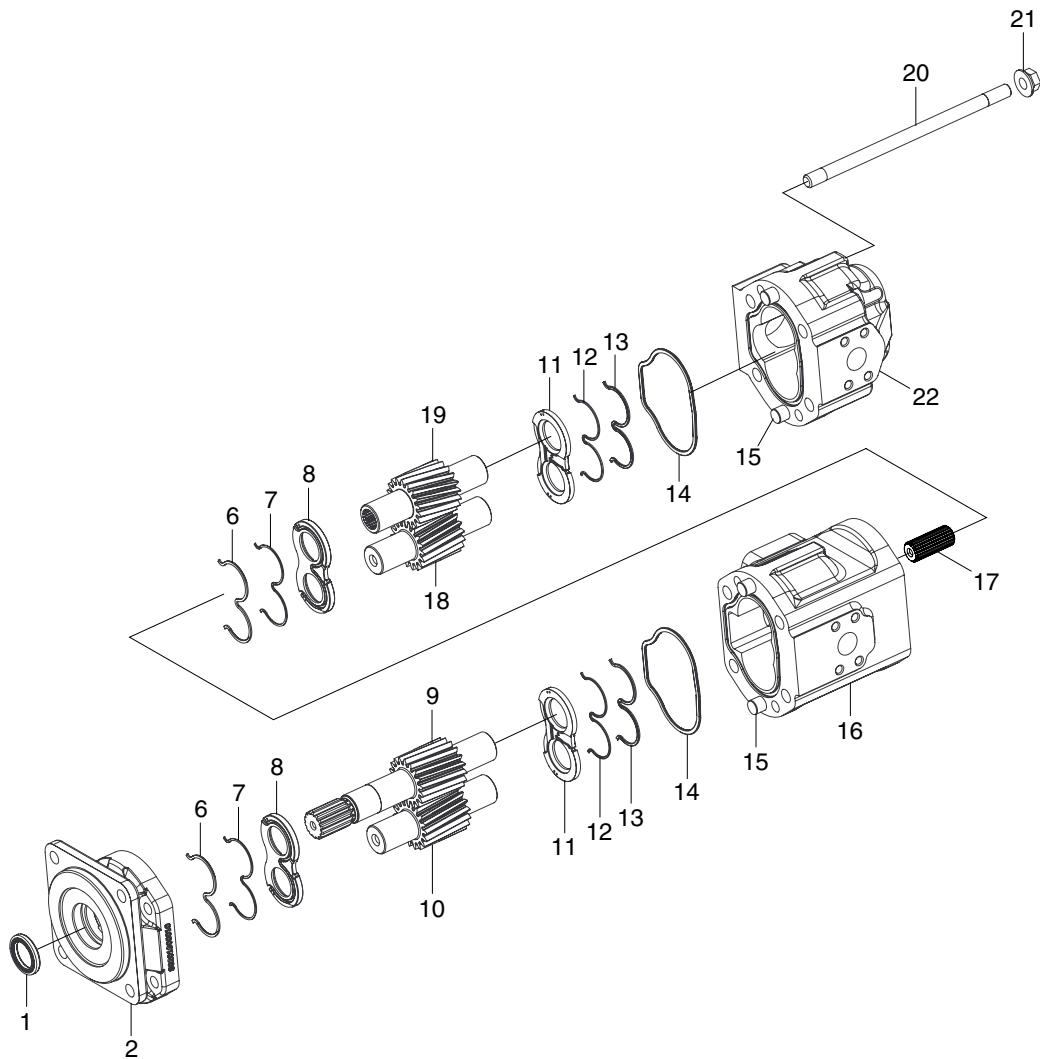

7407WE12

- (5) Fit new interface seal(14) into groove in body.
- (6) Proceed as per paragraph(1)~(5).
- (7) Fit adaptor(2) over the drive gear(9) and fit stud(22).
- (8) Securely clamp unit and tighten nut(21) to half torque and then full torque.
 - Tightening torque : 23.2kgf · m(168lbf · ft)
- (9) Fit shaft seal(1) using appropriate tooling, in correct position and orientation.
- (10) Pour a little clean hydraulic oil into the ports.

2. REMOTE CONTROL VALVE

1) STRUCTURE

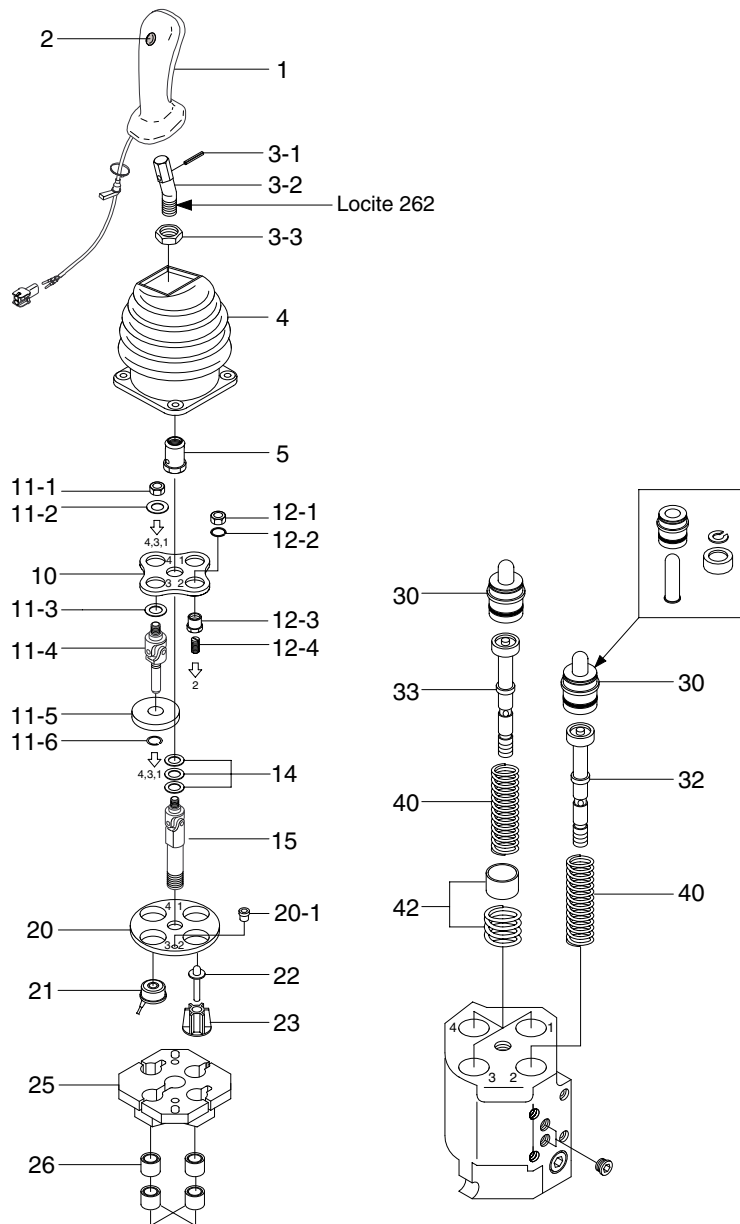

7707WE64

1	Handle	11-4	Cardan	21	Solenoid
2	Push button	11-5	Armature	22	Intermediary plunger kit
3-1	Locking pin	11-6	Spring ring	23	Intermediary plunger guide
3-2	Bent lever	12-1	Counter nut	25	Electric bracket
3-3	Nut	12-2	Spring ring	26	Bushing
4	Rubber boot	12-3	Switch plate screw	30	Plunger kit
5	Locking nut	12-4	Press screw	32	Regulation unit
10	Cardan bracket	14	Shims(0.1, 0.2, 0.5mm)	33	Regulation unit
11-1	Self-locking nut	15	Cardan	40	Return spring
11-2	Washer	20	Flange	42	Prefeeling point kit
11-3	Washer				

2) DISASSEMBLY AND ASSEMBLY

(1) PUSH BUTTEN

- ※ The remote control valve does not need to be removed from the machine to perform this operation.
Remove worn pushbutton using a small screwdriver.
The installation of new elements is performed without any special tools; the parts are simply pressed into place.

(2) RUBBER BOOT

- ① Remove the remote control valve from the machine or free the valve by unscrewing the 4 screws fixing the plate in order to release the electrical cable.
 - Assembly
Torque : 1.02kgf · m(7.4lbf · ft)Hold the remote control valve using a vice or a vice-grip wrench(clamp onto the body).
- ※ The pilot unit does not need to be removed from the machine to release the cable. However, it is recommended to lift the control unit by undoing the 4 fixing screws on the arm rest.
- ※ It is unnecessary to remove the units with no electrical functions.
- ② Lift and turn the boot inside out.
- ③ Remove the grommet(7) from its emplacement to free the cable.
- ④ Loosen the handle mounting nut(3-3) using a 19mm open-end wrench.
 - Assembly : torque 4.08kgf · m(29.5lbf · ft)
- ⑤ Unscrew and remove the handle(1).
 - Assembly
- Add loctite 262 onto the lever thread
- Torque : 4.08kgf · m(29.5lbf · ft)
- ⑥ Replace the faulty rubber boot(4) with a new one.
- ⑦ Replace the handle(1) following the disassembly instructions in reverse order.

(3) HANDLE

- ① Clamp the threaded section of the lever(3-2) in a vice fitted with V-shaped vice clamp.
- ② Remove the pin(3-1) using a 5mm pin driver.
- ③ Replace the lever(3-2) onto the new handle(1) and secure it with the pin(3-1) using a 5mm pin driver.
- ※ Respect the position of the curved lever to ensure that the handle is correctly oriented as indicated by the machine's technical specifications.
- ④ Replace the nut(3-3) on the threaded section and replace the boot(4).

(4) DETENT CARDAN BRACKET KIT

- ※ Remove the 2 grommets(20-1) from the flange (20).
- ※ Place centering sleeves V & W to avoid damaging the cardan knuckles while loosening the nuts.
- ※ Unscrew the locking nut(5) using a 23mm open-end wrench.
 - Assembly : Torque $4.08 \pm 0.4 \text{kgf} \cdot \text{m}$
($29.5 \pm 2.9 \text{lb} \cdot \text{ft}$)

- ① Unscrew the self-locking nut(11-1) using a 13mm open-end wrench.
 - Assembly
 - Torque $1.02 \text{kgf} \cdot \text{m}$ ($7.4 \text{lb} \cdot \text{ft}$)
 - Place centering sleeves(V-W) to avoid damaging the cardan knuckles while screwing the nuts.
- ② Remove : - Friction washer(11-2)
 - Friction washer(11-3)
 - Cardan/armature assembly (11-4 ~ 11-6)

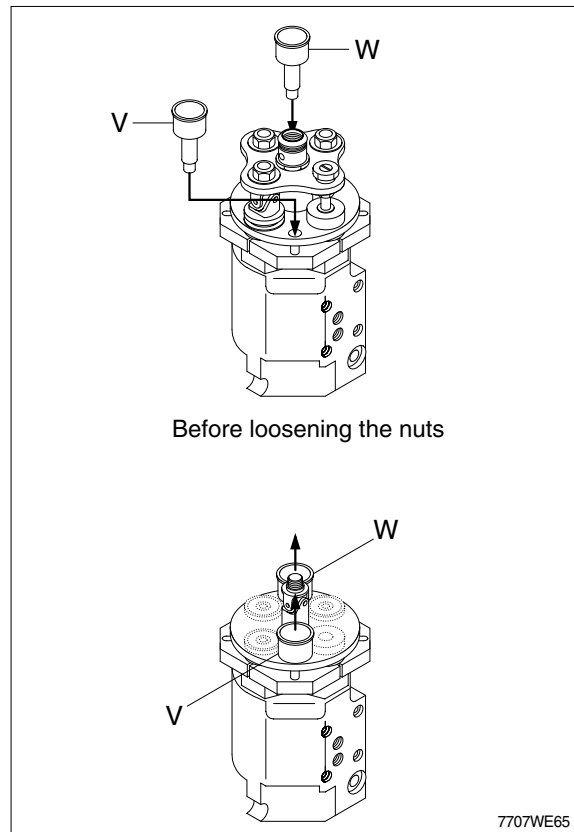

(5) NON-DETENT PLUNGER KIT

- ① Unscrew the self-locking nut(12-1) using a 13mm open-end wrench.
 - Reassembly : - Torque $1.02 \text{kgf} \cdot \text{m}$ ($7.4 \text{lb} \cdot \text{ft}$)
 - Place centering sleeves(V-W) to avoid damaging the cardan knuckles while screwing the nuts.
- ② Undo the snap ring(12-2) using a flat-end screwdriver.
- ③ Remove the screw assembly(12-3, 12-4)

(6) CARDAN

- ① Remove the centering sleeves **V** & **W**.
- ② Remove the cardan bracket(10) and the shims(14).
- ③ Unscrew the cardan(15) using a 17mm open-end wrench.
 - Reassembly : - Ungrease the cardan threads
 - Add loctite 262 onto the cardan threads(both end)
 - Torque $4.08 \text{kgf} \cdot \text{m}$ ($29.5 \text{lb} \cdot \text{ft}$)

(7) SOLENOID AND CONNECTOR

- ※ It is advised to mount the connector onto the solenoid cable once the remote control valve is assembled.
- ① Remove the flange(20) and the electrical bracket(25),
 - ② Remove the protecting bushes(26) from the electrical bracket(25).
 - ③ Undo the solenoid(21) from the electric bracket(25).
 - ④ Replace the solenoid.
 - ※ Clean the polar face using a piece of cloth and pay attention not to hit them.
 - ⑤ Assembly : Place the solenoid cable in its emplacement on the electric bracket before fitting the protection bushes.

(8) INTERMEDIARY PLUNGER KIT

- ① Undo the intermediary plunger guide(23).
- ② Remove and replace the intermediary plunger kit assembly(22).

(9) GUIDE / PLUNGER AND REGULATION UNIT

- ※ Beware of the plungers that might jump out due to the spring return.
- ① Remove : - Guide/plunger assembly(30).
 - Regulation unit(32/33).
 - Return spring(40).
 - Pre-feeling point kit(42).
 - ② The remote control valve is now totally disassembled.
Assemble in reverse order following the torque specification.

3. MAIN CONTROL VALVE

1) Lay out valve components on a clean, flat working surface. The inlet assembly will include an O-ring, and the spool section(s) include an O-ring, a load check poppet and a load check spring. Tools required for basic valve assembly include 3/4 and 11/16 open or box end wrenches and a torque wrench with thin wall sockets.

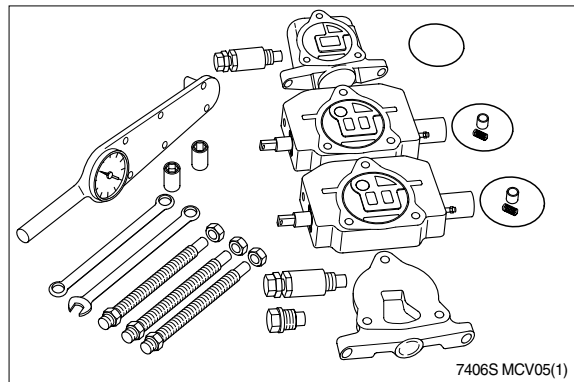

2) Assemble tie rod nuts to one end of each tie rod with one or two threads showing. Insert tie rods through tie rod holes of inlet(Large tie rod at top). Lay inlet on end with tie rods up, place O-ring into position.

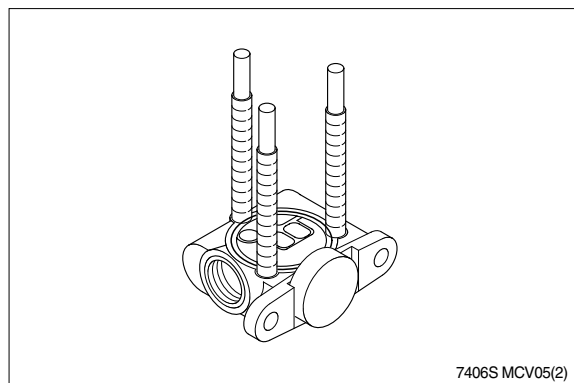

3) Place first spool section(O-ring side up) on inlet section, position O-ring and insert load check poppet(Nose down) and spring(Behind poppet) into load check cavity as shown. Repeat this procedure for each spool section ; The load check springs are compressed by the following sections during assembly.

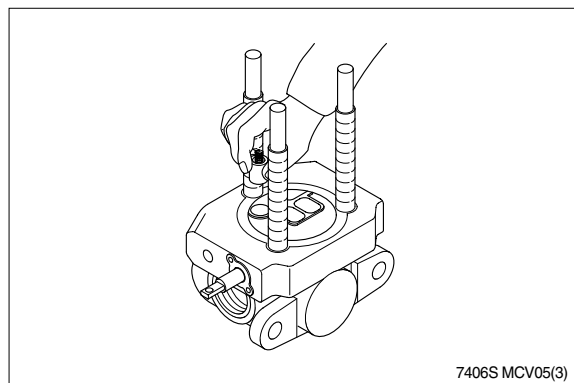

4) Position end section on last spool section as shown and hand tighten tie rod nuts. The end section on picture is a "turn around" section without ports. Universal outlet/power beyond section and power beyond and closed center sections are also used as end sections. These end sections do not have O-ring grooves.

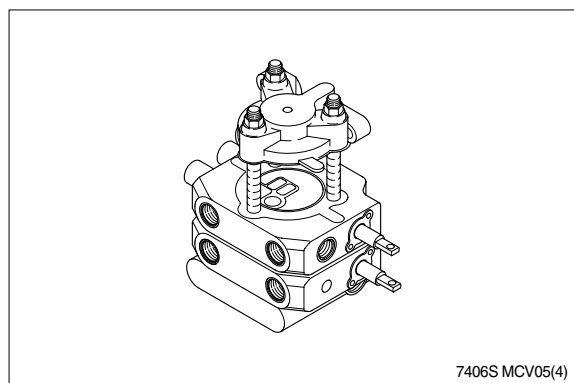

- 5) Position valve assembly with the mounting pads of the end sections on a flat surface. To obtain proper alignment of end sections relative to the spool sections apply downward pressure to the end sections ; Snug tie rod nuts to about 10lbf · ft. Final torque the two 11/16 nuts to 48 ± 5 lbf · ft ; Final torque the 3/4 nut to 74 ± 8 lbf · ft. Check for proper spool movement.

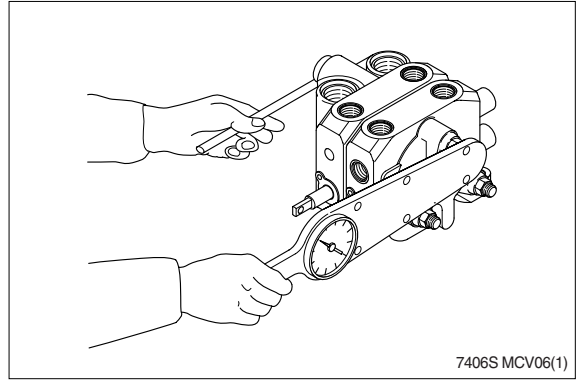

- 6) Install auxilliary valves and plugs and torque to proper specifications.
- ※ **General assembly notes :**
- A. Lever assemblies can be installed on section before or after complete valve assembly.
 - B. The load check and spring may be omitter from assembly in certain circuit conditions(i.e., motor spools).

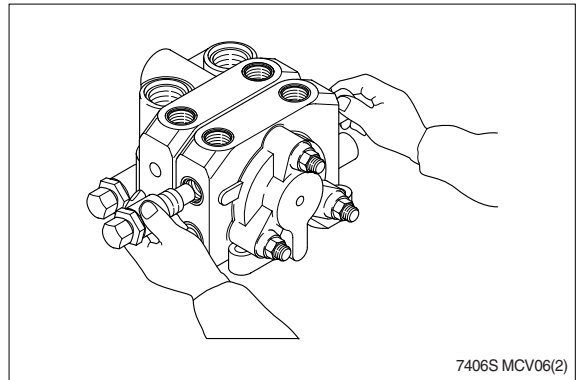

4. BOOM AND BUCKET CYLINDER

1) BOOM CYLINDER

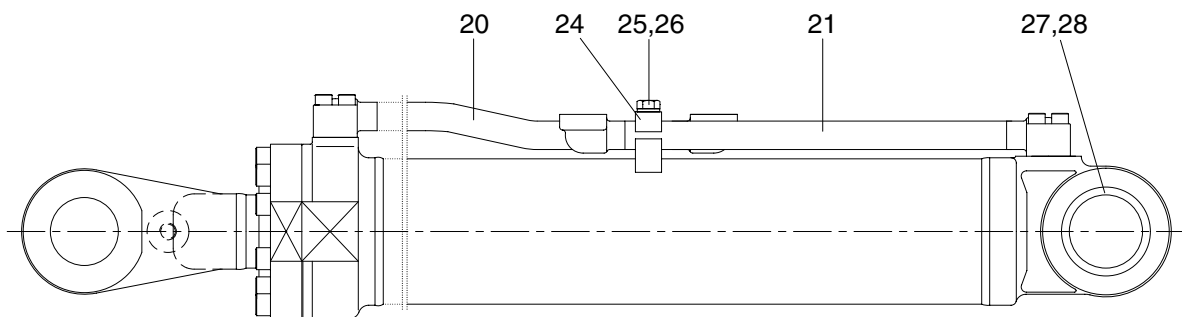
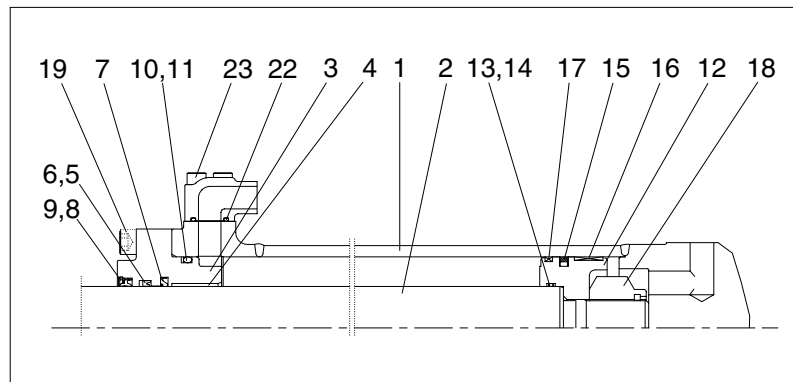

7407WE10

- | | | | | | |
|----|--------------|----|--------------|----|---------------|
| 1 | Tube assy | 11 | Back up ring | 21 | Pipe assy |
| 2 | Rod assy | 12 | Piston | 22 | O-ring |
| 3 | Gland | 13 | O-ring | 23 | Socket bolt |
| 4 | Bushing | 14 | Back up ring | 24 | Pipe clamp |
| 5 | Rod seal | 15 | Piston seal | 25 | Hexagon bolt |
| 6 | Back up ring | 16 | Wear ring | 26 | Spring washer |
| 7 | Buffer ring | 17 | Dust ring | 27 | Bushing |
| 8 | Dust wiper | 18 | Nylon nut | 28 | Dust seal |
| 9 | Snap ring | 19 | Socket bolt | | |
| 10 | O-ring | 20 | Pipe assy | | |

2) BUCKET CYLINDER

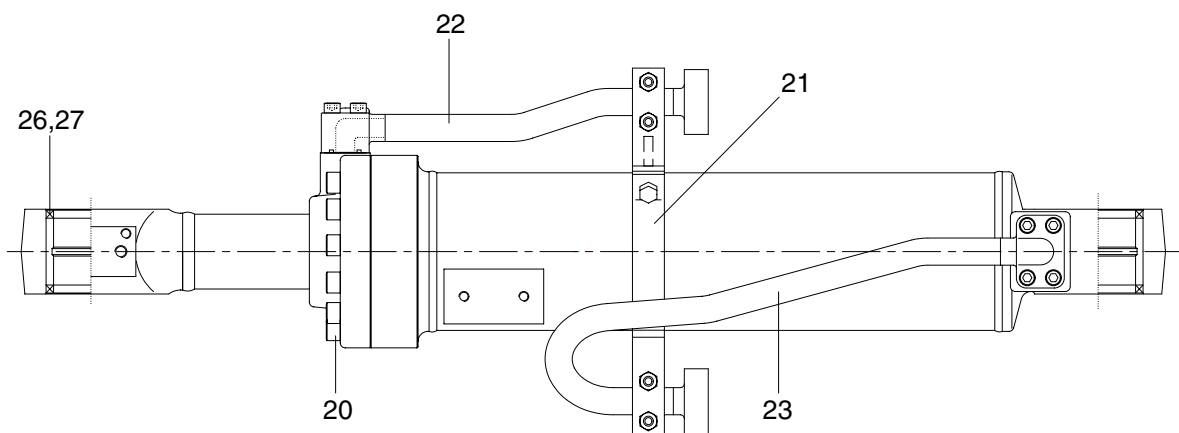
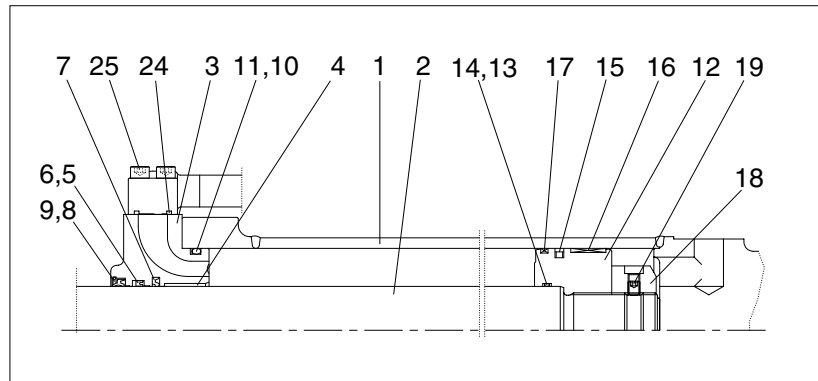

7407WE11

- | | | | | | |
|---|--------------|----|--------------|----|-------------|
| 1 | Tube assy | 10 | O-ring | 19 | Set screw |
| 2 | Rod assy | 11 | Back up ring | 20 | Socket bolt |
| 3 | Gland | 12 | Piston | 21 | Band assy |
| 4 | Bushing | 13 | O-ring | 22 | Pipe assy |
| 5 | Rod seal | 14 | Back up ring | 23 | Pipe assy |
| 6 | Back up ring | 15 | Piston seal | 24 | O-ring |
| 7 | Buffer ring | 16 | Wear ring | 25 | Socket bolt |
| 8 | Dust wiper | 17 | Dust ring | 26 | Bushing |
| 9 | Snap ring | 18 | Nylon nut | 27 | Dust seal |

3) TOOLS AND TIGHTENING TORQUE

(1) Tools

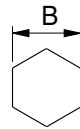
Tool name	Remark	
Allen wrench	8	
	12	
Spanner	19	
(-) Driver	Small and large sizes	
Torque wrench	Capable of tightening with the specified torques	

(2) Tightening torque

Part name		Item	Size	Torque	
				kgf · m	lbf · ft
Socket head bolt	Bucket cylinder	20	M14 × 2.0 × 55	15 ± 2	108 ± 14.5
	Boom cylinder	19			
	Bucket cylinder	25	M10 × 1.5 × 45	5.4 ± 0.5	39 ± 3.6
	Boom cylinder	23			
Nylon nut	Bucket cylinder	18	M64 × 3.0	150 ± 15	1085 ± 108
	Boom cylinder		M48 × 2.0	250 ± 25	1808 ± 181
Hex head bolt	Boom cylinder	25	M12 × 1.75 × 40	5.5 ± 0.6	40 ± 4.3

4) DISASSEMBLY

(1) Remove gland and piston rod

- ① Hold the clevis section of the tube in a vise. Use mouth pieces so as not to damage the machined surface of the cylinder tube. Do not make use of the outside piping as a locking means.

- ② Pull out piston rod(2) about 200mm (7.8 in). Because the piston rod is rather heavy, finish extending it with air pressure after the oil draining operation.

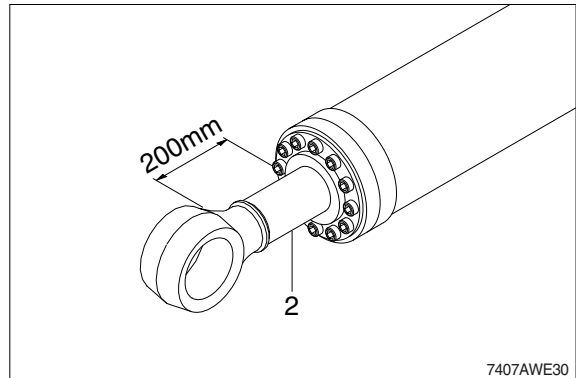

- ③ Loosen and remove socket bolts(19) of the gland(3) in sequence.
* Cover the extracted piston rod(2) with rag to prevent it from being accidentally damaged during operation.

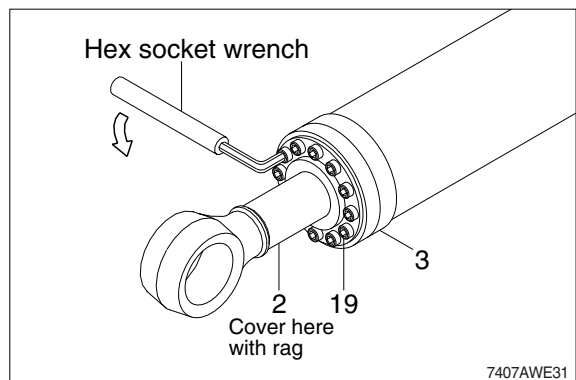

- ④ Draw out gland(3) and piston rod (2) assembly together from cylinder tube(1).
* Since the piston rod assembly is heavy in this case, lift the tip of the piston rod(2) with a crane or some means and draw it out. However, when piston rod(2) has been drawn out to approximately two thirds of its length, lift it in its center to draw it completely.

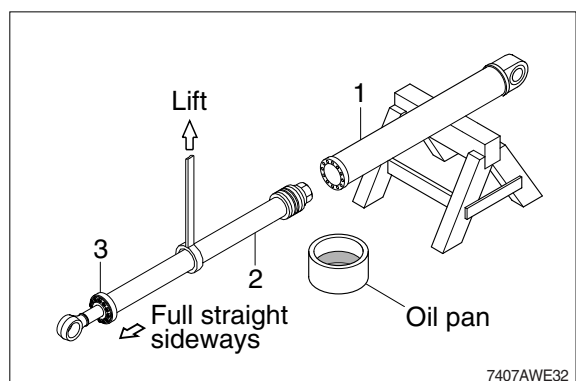

- ※ Note that the plated surface of piston rod(2) is to be lifted. For this reason, do not use a wire sling and others that may damage it, but use a strong cloth belt or a rope.

- ⑤ Place the removed piston rod assembly on a wooden V-block that is set level.
- ※ Cover a V-block with soft rag.

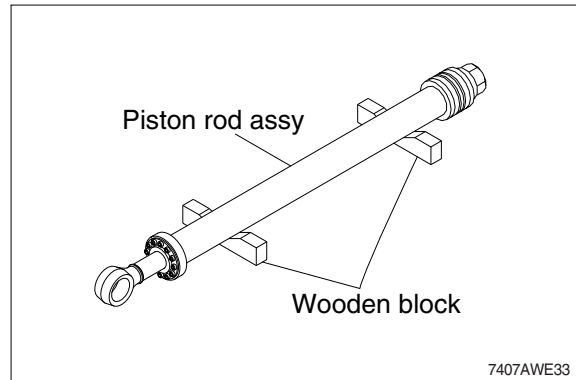

(2) Remove piston and gland assembly

- ① Remove the nylon nut(18).
- ② Remove piston assembly(12) and O-ring (13), back up ring(14).

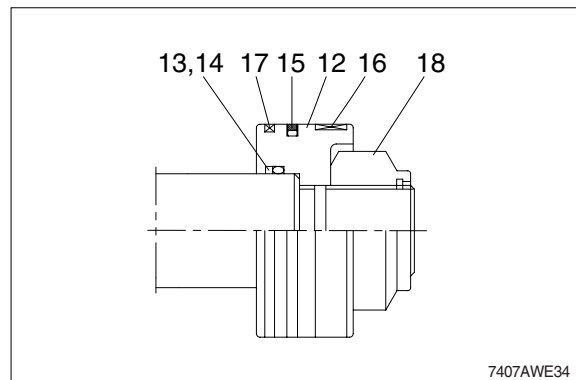

- ③ Remove the gland assembly from piston rod(2).
 - ※ If is too heavy to move, move it by striking the flanged part of gland(3) with a plastic hammer.
 - ※ Pull it straight with gland assembly lifted with a crane.
- Exercise care so as not to damage the lip of rod bushing(4) and packing(5, 6, 7, 8, 9) by the threads of piston rod(2).

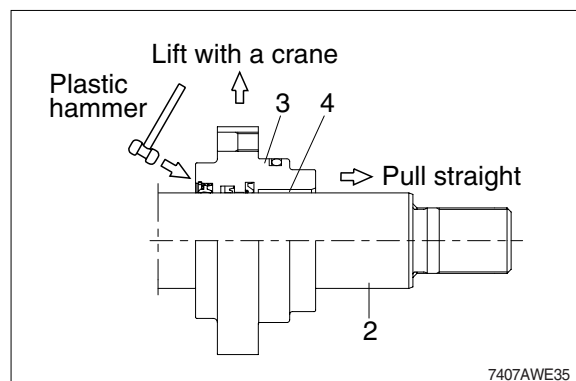

(3) Disassemble the piston assembly

- ① Remove wear ring(16), dusting(17), and piston seal (15).
- ※ Exercise care in this operation not to damage the grooves.

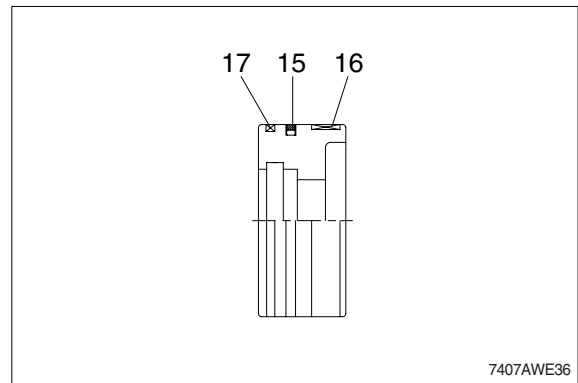

(4) Disassemble gland assembly

- ① Remove back up ring(11) and O-ring (10).
 - ② Remove snap ring(9) and dust wiper(8).
 - ③ Remove back up ring(6), rod seal(5) and buffer ring(7).
- ※ Exercise care in this operation not to damage the grooves.
- ※ Do not remove seal and ring, if does not damaged.

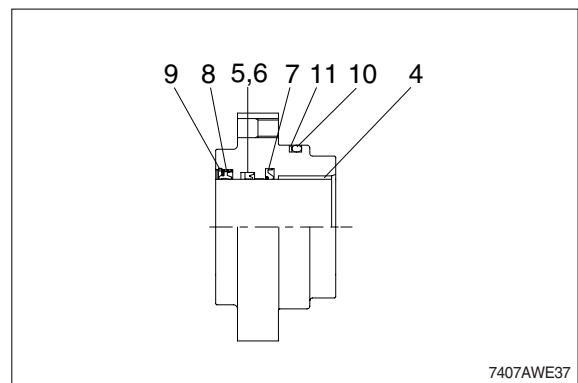

5) ASSEMBLY

(1) Assemble gland assembly

※ Check for scratches or rough surfaces if found smooth with an oil stone.

- ① Coat the inner face of gland(3) with hydraulic oil.

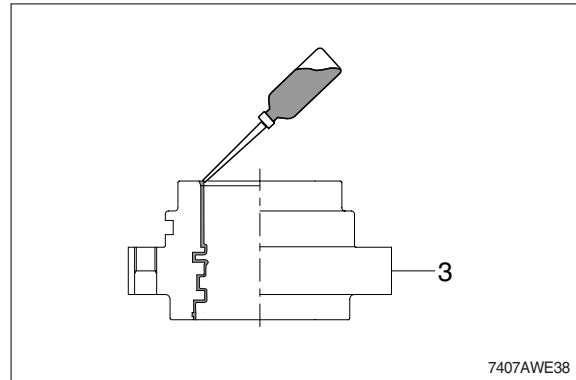

- ② Coat dust wiper(8) with grease and fit dust wiper(8) to the bottom of the hole of dust wiper.

- ③ At this time, press a pad metal to the metal ring of dust seal.
Fit snap ring(9) to the stop face.

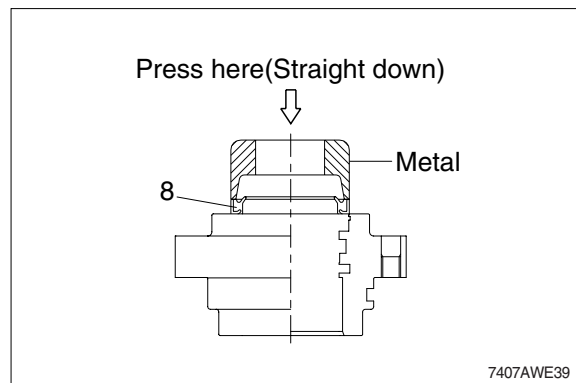

- ④ Fit back up ring(6), rod seal(5) and buffer ring(7) to corresponding grooves, in that order.

- ※ Coat each packing with hydraulic oil before fitting it.
- ※ Insert the backup ring until outside of it is inserted into groove.

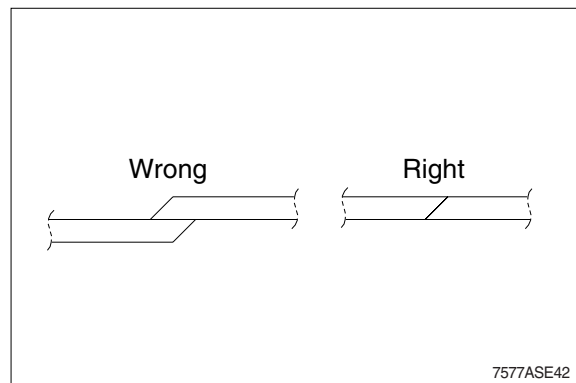

- ※ Rod seal(5) has its own fitting direction. Therefore, confirm it before fitting them.
- ※ Fitting rod seal(5) up side down may damage its lip. Therefore check the correct direction that is shown in fig.

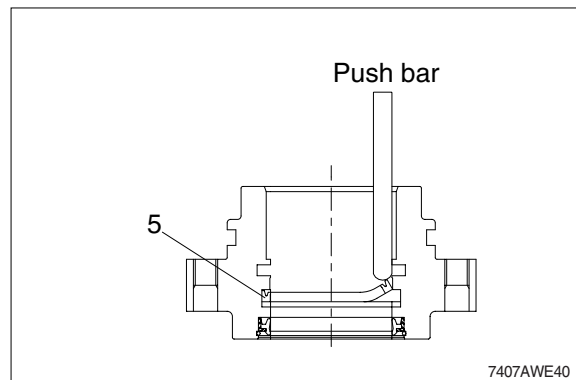

- ⑤ Fit back up ring(11) to gland(3).
- ※ Put the backup ring in the warm water of 30~50°C.
- ⑥ Fit O-ring(10) to gland(3).

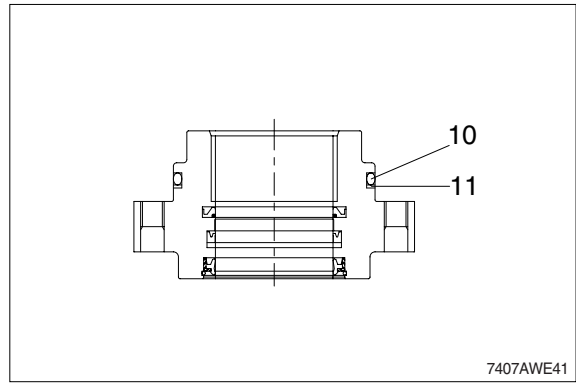

(2) Assemble piston assembly

- ※ Check for scratches or rough surfaces if found smooth with an oil stone.
- ① Coat the outer face of piston(12) with hydraulic oil.

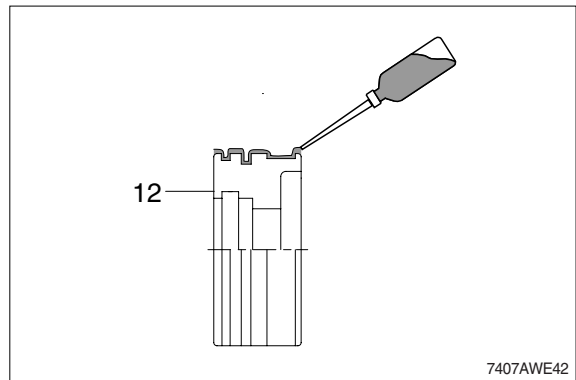

- ② Fit piston seal(15) to piston
- ※ Put the piston seal in the warm water of 60~100°C for more than 5 minutes.
- ※ After assembling the piston seal, press its outer diameter to fit in.

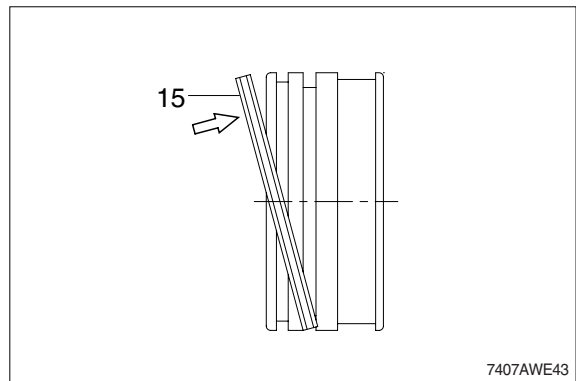

- ③ Fit wear ring(16), dust ring(17) to piston(12).
- ④ Fit O-ring(13) and backup ring(14) to piston(12).

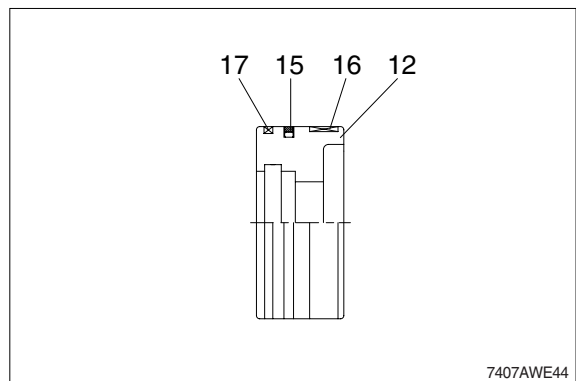

(3) Install piston and gland assembly

- ① Fix the piston rod assembly to the work bench.
- ② Apply hydraulic oil to the outer surface of piston rod(2), the inner surface of piston and gland.
- ③ Insert gland assembly to piston rod(2).

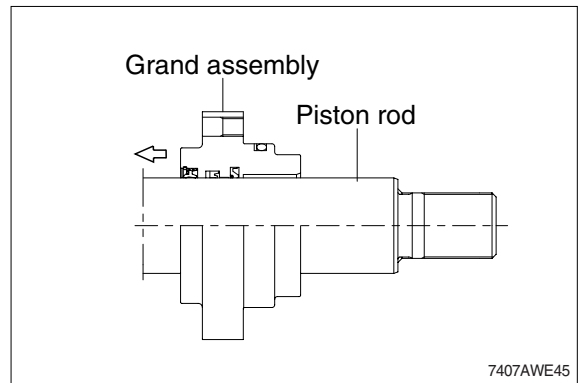

- ④ Fit piston assembly to piston rod.

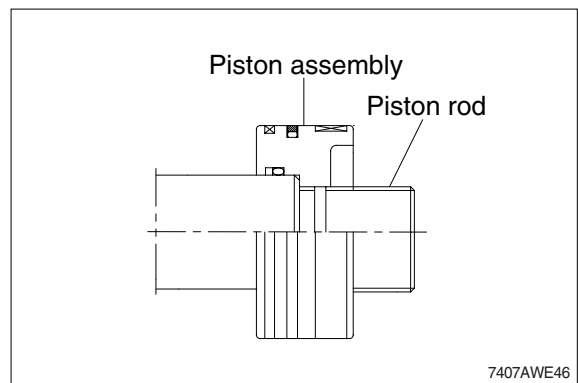

- ⑤ Tighten nylon nut(18) to piston rod(2)
 - Tightening torque : $250 \pm 25 \text{ kgf} \cdot \text{m}$
($1808 \pm 181 \text{ lbf} \cdot \text{ft}$)

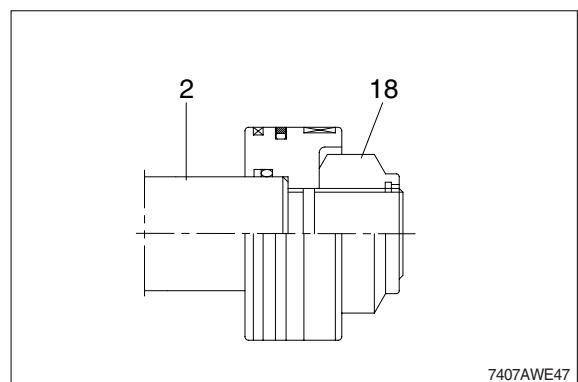

(4) Overall assemble

- ① Place a V-block on a rigid work bench.
Mount the cylinder tube assembly(1) on it and fix the assembly by passing a bar through the clevis hole to lock the assembly.
- ② Insert the piston rod assembly in to the cylinder tube assembly, while lifting and moving the piston rod assembly with a crane.
 - ※ Be careful not to damage piston seal by thread of cylinder tube.
- ③ Match the bolts holes in the cylinder head flange to the tapped holes in the cylinder tube assembly and tighten socket bolts to a specified torque.
 - ※ Refer to the table of tightening torque.

