

## GROUP 6 TROUBLESHOOTING

### 1. WHEN STARTING SWITCH IS TURNED ON, CLUSTER LAMP DOES NOT LIGHT UP

- Before carrying out below procedure, check all the related connectors are properly inserted and the fuse No.26 is not blown out and ON/OFF of bulb.
- After checking, connect the disconnected connectors again immediately unless otherwise specified.

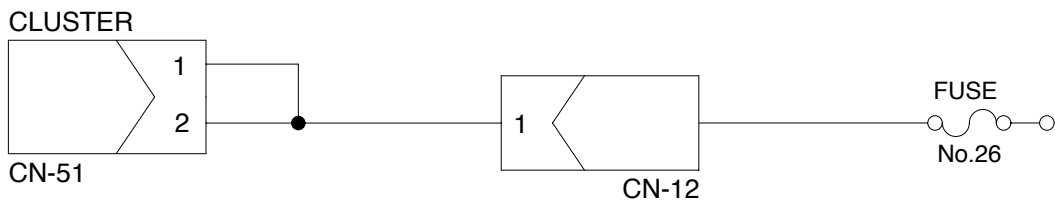
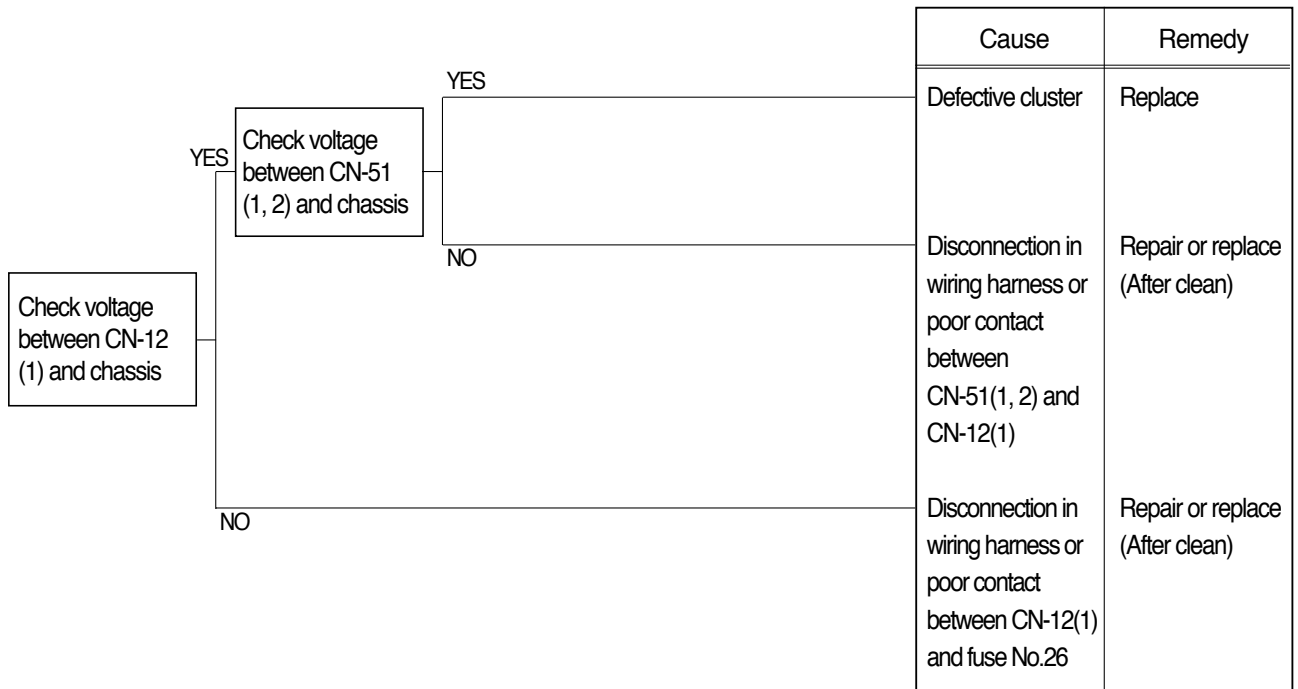

#### Check voltage

YES	20 ~ 30V
NO	0V

7607EL14

## 2. WHEN BATTERY LAMP LIGHTS UP (Engine is started)

- Before carrying out below procedure, check all the related connectors are properly inserted.
- After checking, connect the disconnected connectors again immediately unless otherwise specified.

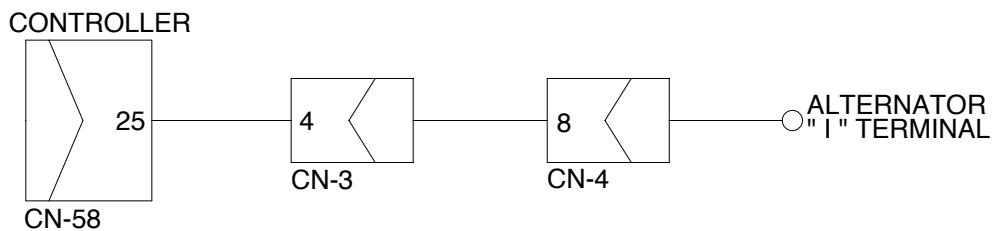
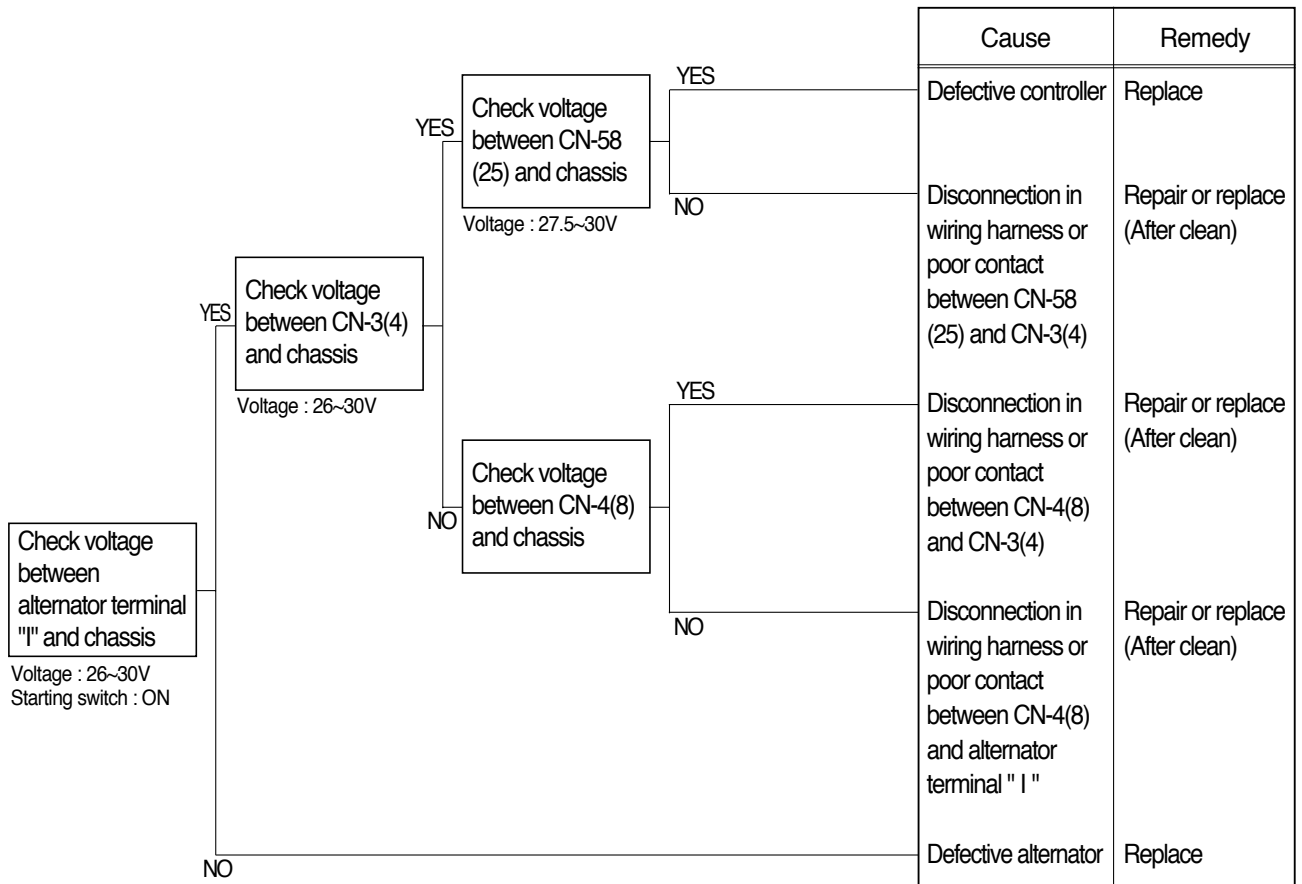

### Check voltage

YES	20 ~ 30V
NO	0V

7707EL23

### 3. WHEN PARKING SOLENOID DOES NOT WORK

- Before carrying out below procedure, check all the related connectors are properly inserted and the fuse No.8 is not blown out.
- After checking, connect the disconnected connectors again immediately unless otherwise specified.

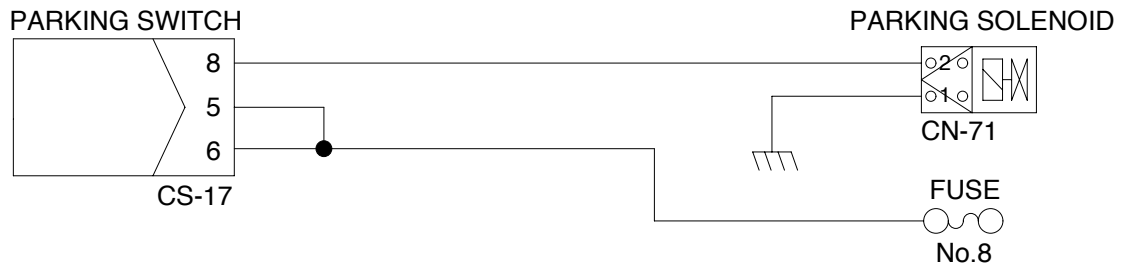
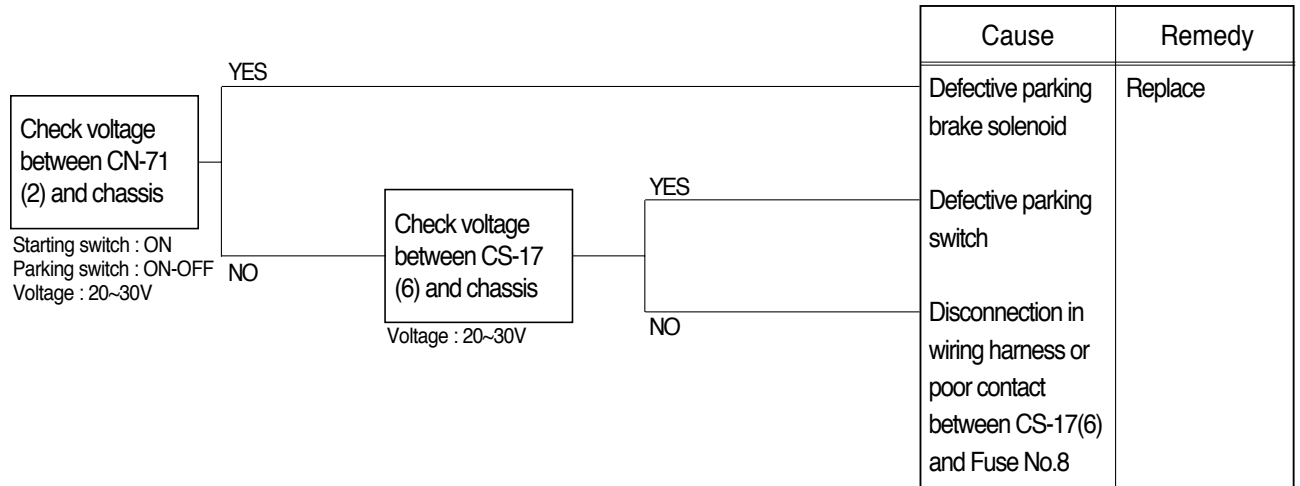

7407EL24

#### 4. TRANSMISSION IS NOT RETURNED TO NEUTRAL WHEN PARKING BRAKE IS APPLIED

- Before carrying out below procedure, check all the related connectors are properly inserted and the fuse No.17(T/M controller) and No.8 are not blown out.
- After checking, connect the disconnected connectors again immediately unless otherwise specified.

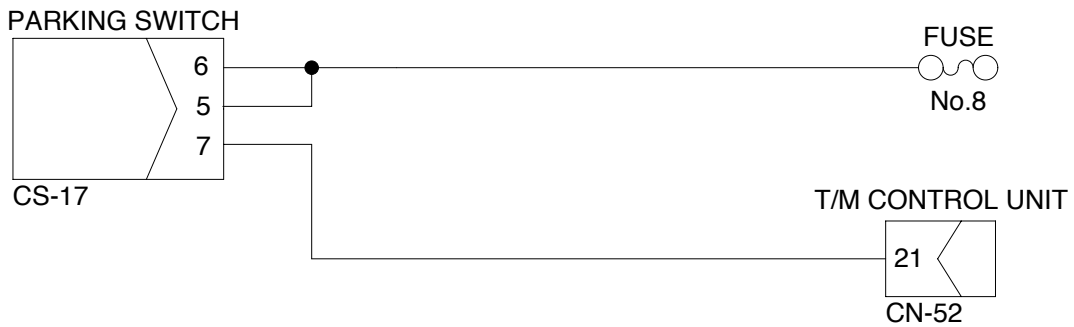
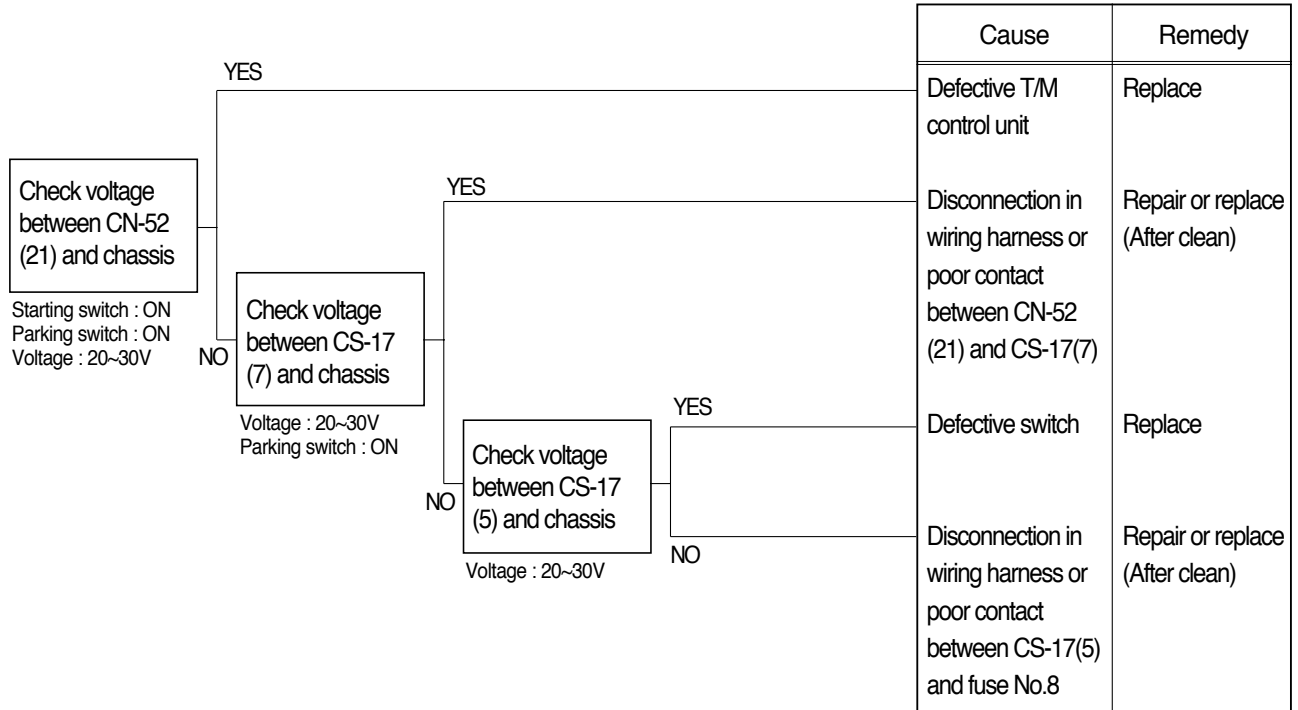

#### Check resistance

YES	MAX 1
NO	MIN 1M

## 5. MACHINE DOES NOT TRAVEL

- Before carrying out below procedure, check all the related connectors are properly inserted and the fuse No.17(Transmission control unit) is not blown out.
- After checking, connect the disconnected connectors again immediately unless otherwise specified.
- Wiring diagram : **See page 7-16.**

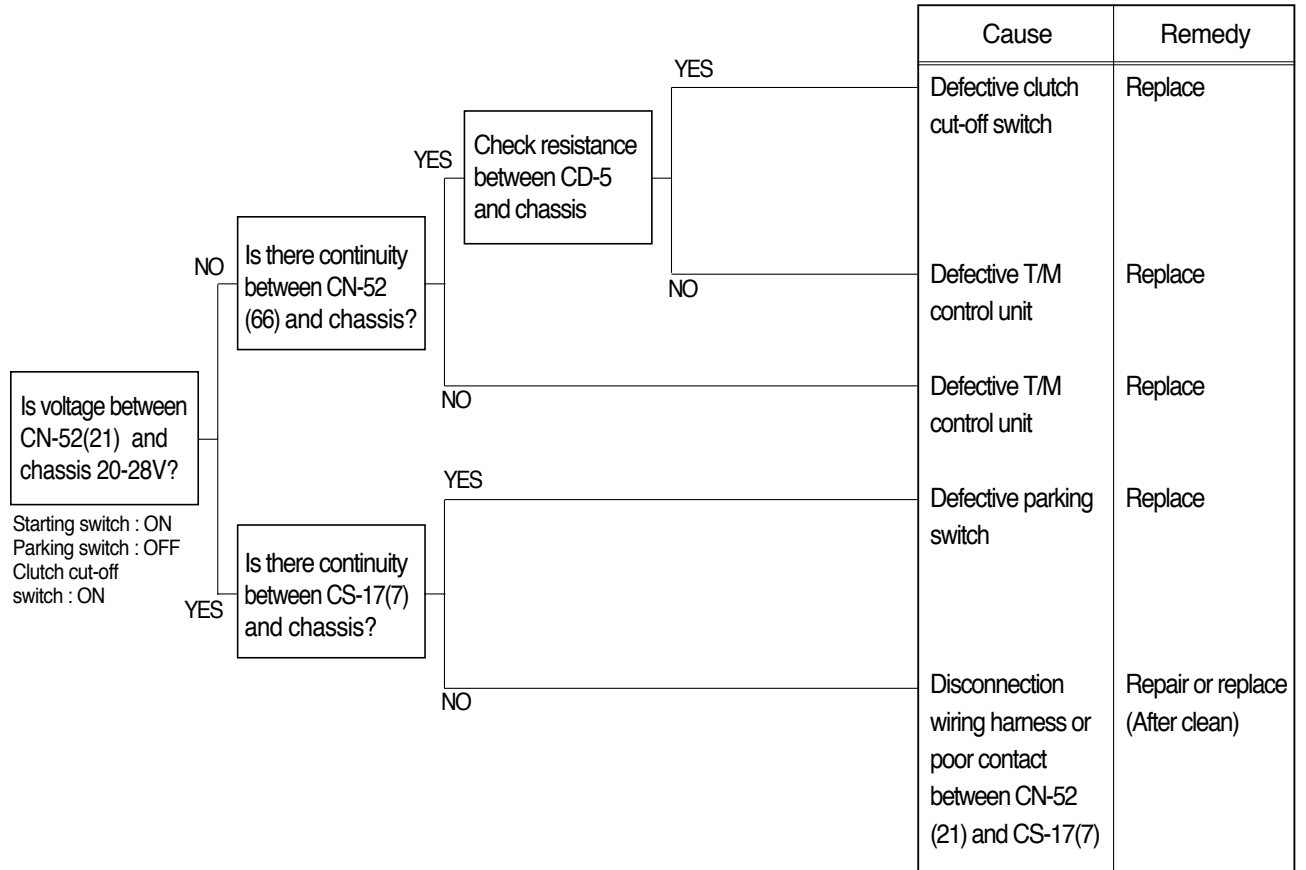

### Check resistance

YES	MAX 1
NO	MIN 1M

## 6. WHEN STARTING SWITCH IS TURNED ON, WIPER MOTOR DOES NOT OPERATE

- Before carrying out below procedure, check all the related connectors are properly inserted and the fuse No.9 is not blown out.
- After checking, connect the disconnected connectors again immediately unless otherwise specified.

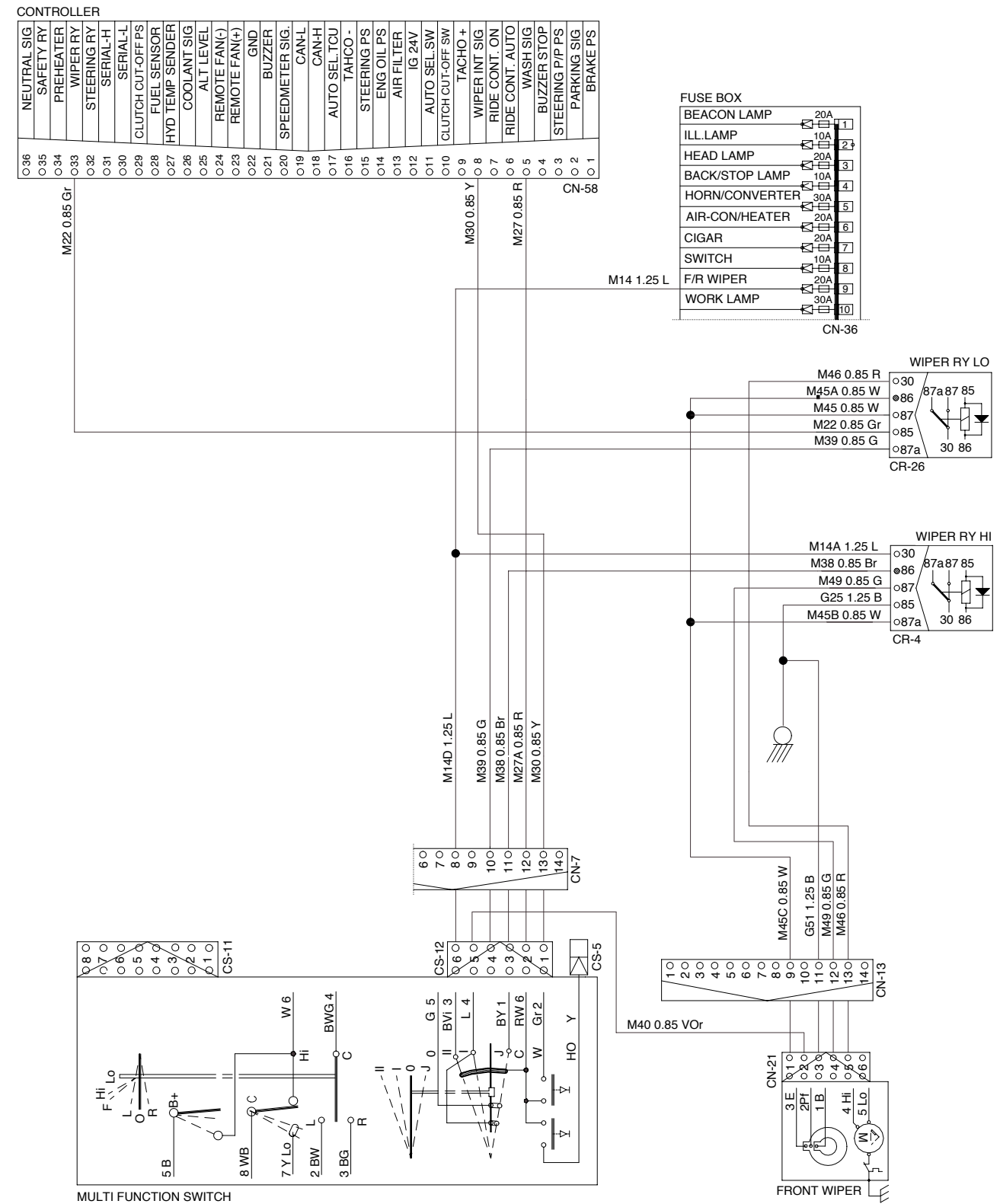
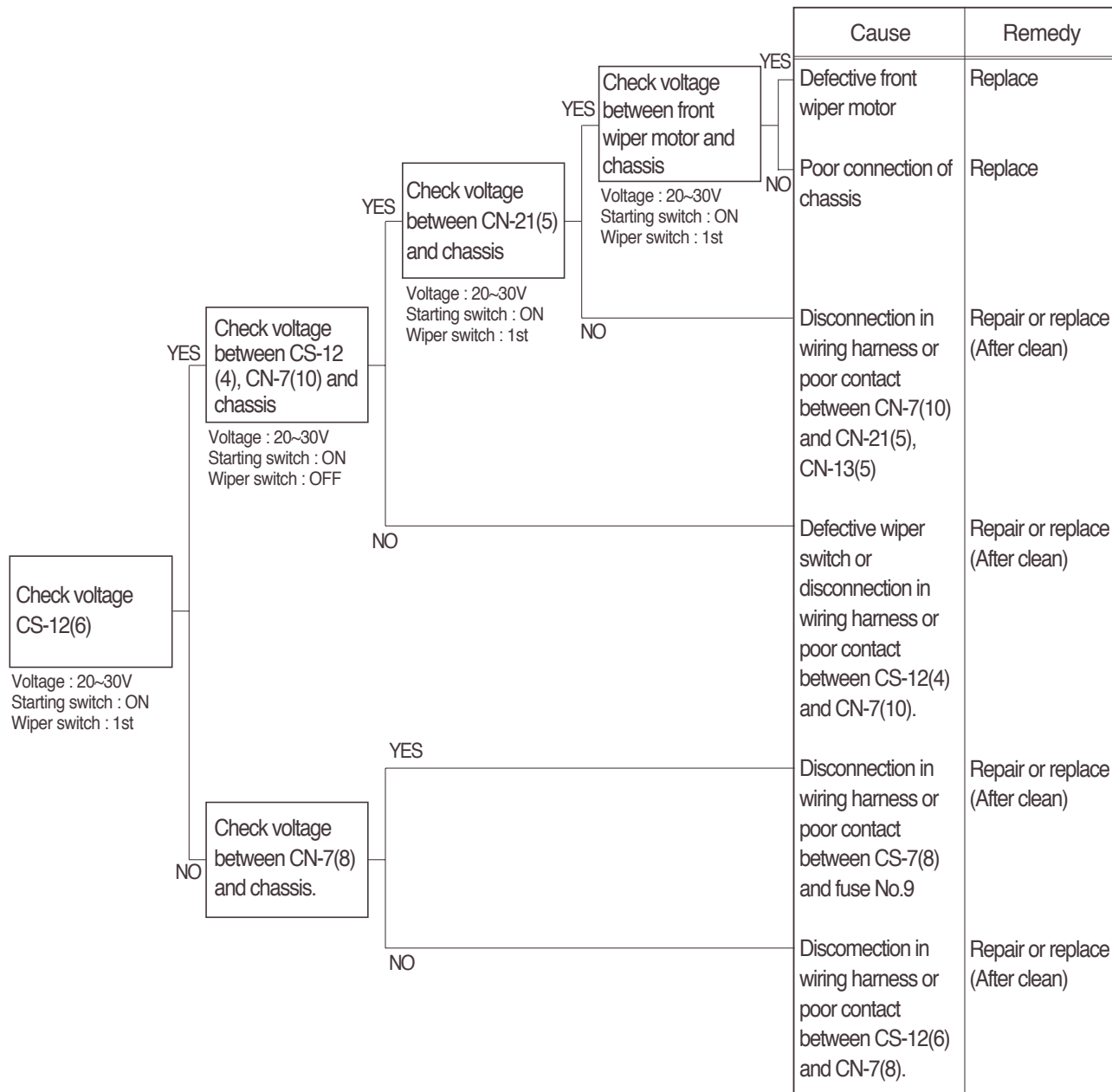

## 7. WHEN STARTING SWITCH "ON" DOES NOT OPERATE

- Before carrying out below procedure, check all the related connectors are properly inserted and and the fuse No.16 is not blown out.
- After checking, connect the disconnected connectors again immediately unless otherwise specified.

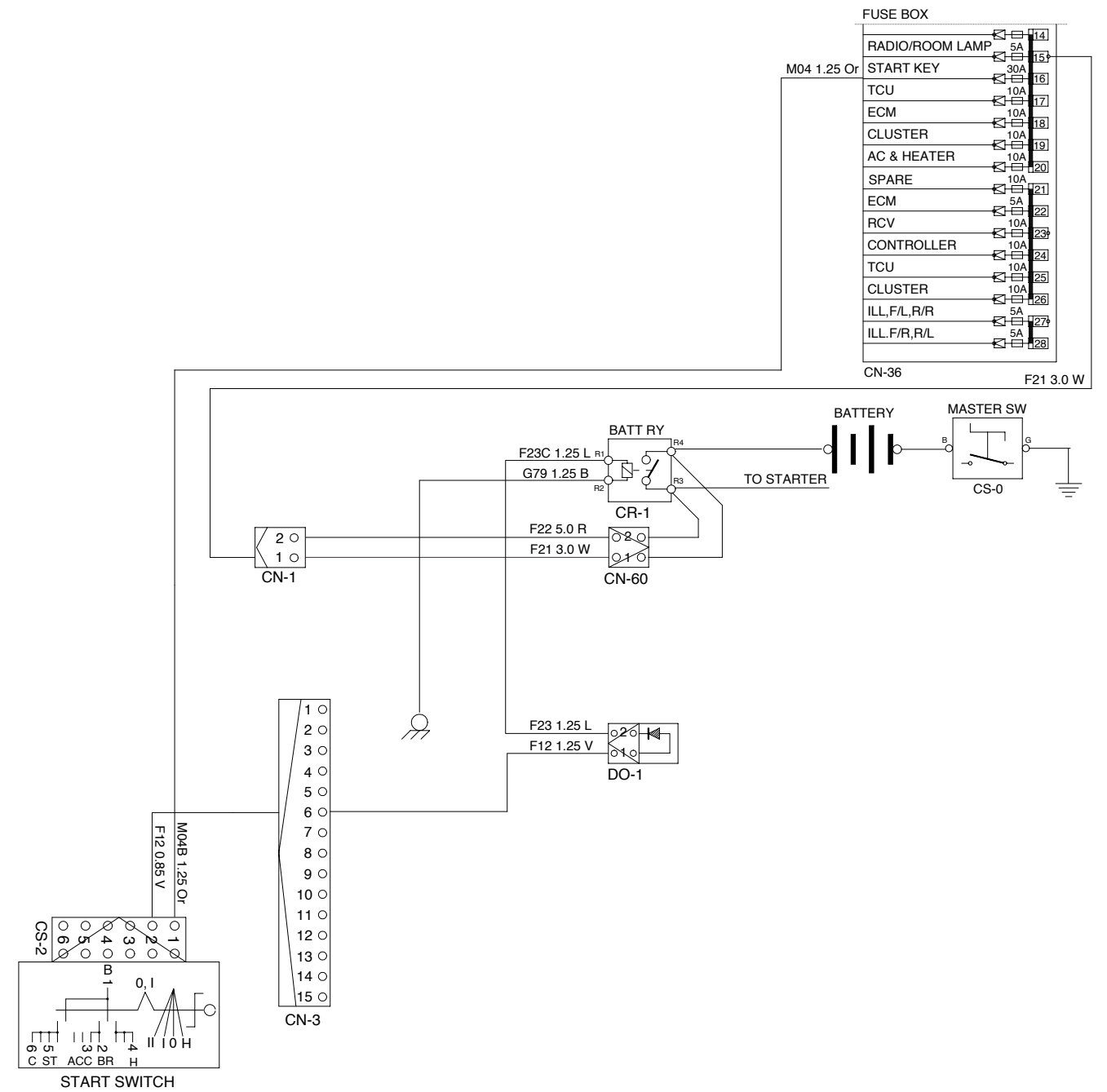
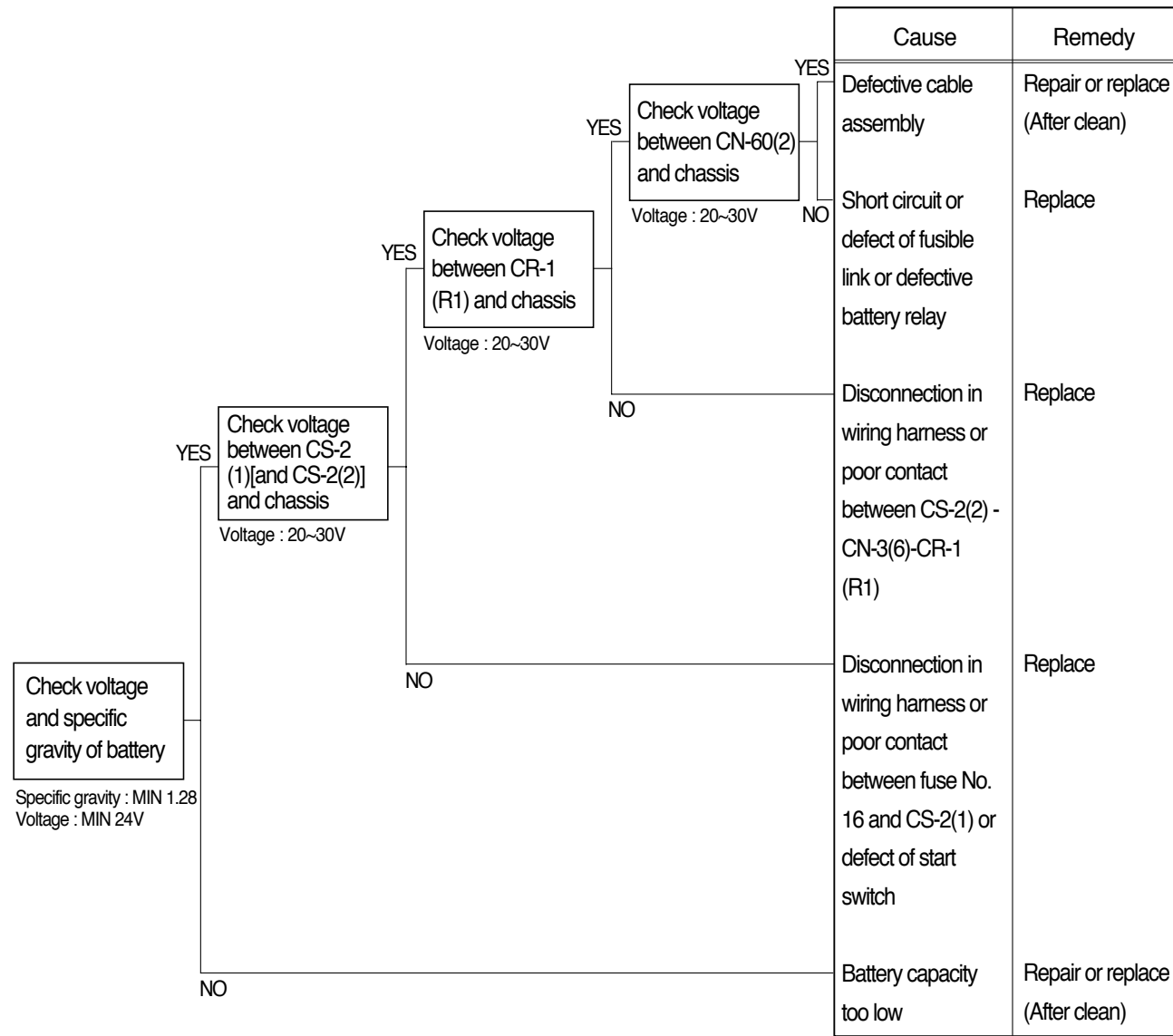

## 8. WHEN STARTING SWITCH IS TURNED ON, WORK LAMP DOES NOT LIGHTS UP

- Before carrying out below procedure, check all the related connectors are properly inserted, and the fuse No.10 is not blown out.
- After checking, connect the disconnected connectors again immediately unless otherwise specified.

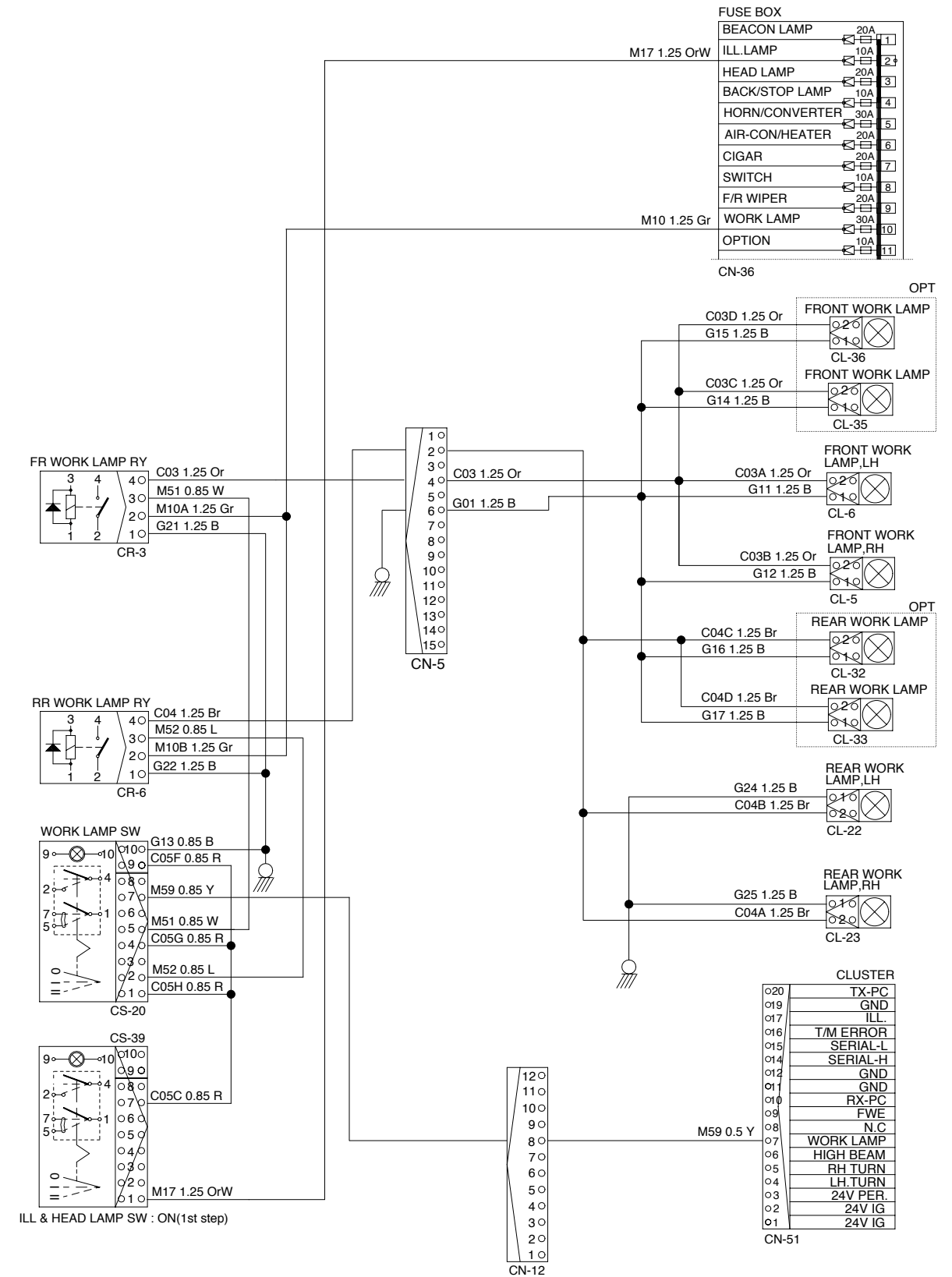
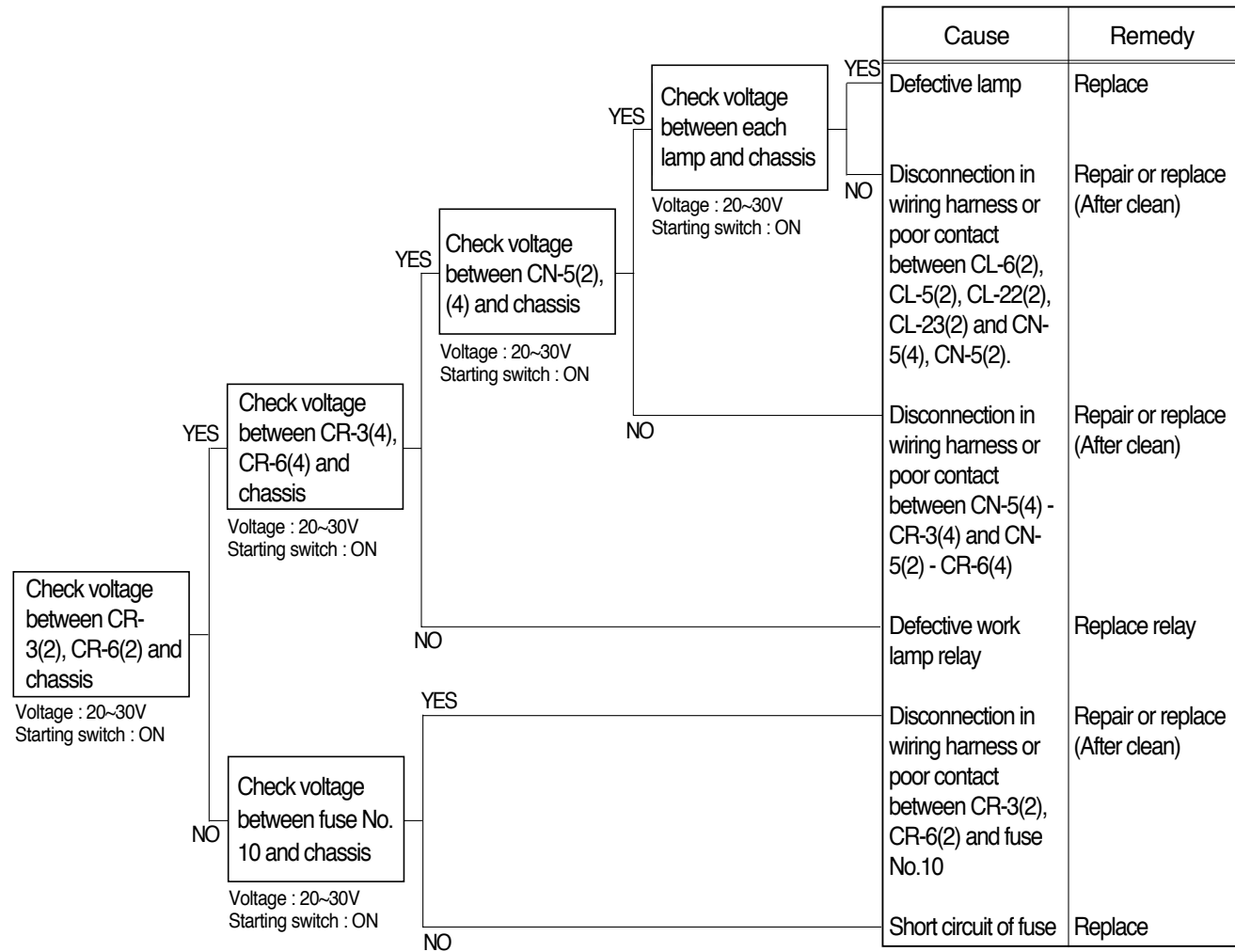



## 9. WHEN ENGINE DOES NOT START

- Check supply of the power at engine stop solenoid while starting switch is ON.
- Before carrying out below procedure, check all the related connectors are properly inserted.
- After checking, connect the disconnected connectors again immediately unless other wise specified.
- Check forward reverse switch at neutral position.

