

SECTION 6 WORK EQUIPMENT

Group 1	Structure and Function	6-1
Group 2	Operational Checks and Troubleshooting	6-40
Group 3	Tests and Adjustments	6-51
Group 4	Disassembly and Assembly	6-67

SECTION 6 WORK EQUIPMENT

GROUP 1 STRUCTURE AND FUNCTION

1. HYDRAULIC SYSTEM OUTLINE

The loader hydraulic system is a pilot operated, open center system which is supplied with flow from the fixed displacement main hydraulic pump.

The pilot control system is a low pressure, closed center hydraulic system which is supplied with flow from the first(Steering) pump.

The loader system components are :

- Main pump
- Main control valve
- Bucket cylinder
- Boom cylinders
- Pilot supply unit
- Remote control valve(Pilot control valve)
- Safety valve

The pilot supply unit consists of the pressure reducing valve, relief valve and accumulator.

Flow from the main hydraulic pump not used by the steering system leaves the priority valve EF port. It flows to the inlet port plate of four blocks type main control valve.

The main control valve is a tandem version spool type, open center valve which routes flow to the boom, bucket or auxiliary cylinders(Not shown) when the respective spools are shifted.

Flow from the steering pump(The first pump) is routed to the pilot supply unit where the steering pump outlet pressure is reduced to pilot circuit pressure. The pilot supply unit flow to the remote control valve.

The remote control valve routed flow to either end of each spool valve section in the main control valve to control spool stroke.

A accumulator mounted on pilot supply unit supplies a secondary pressure source to operated remote control valve so the boom can be lowered if the engine is off.

The return circuit for the main hydraulic system have return filter inside the hydraulic tank. The return filter uses a filter element and a bypass valve. The bypass valve is located in the upside of filter.

2. HYDRAULIC CIRCUIT(HL740-7)

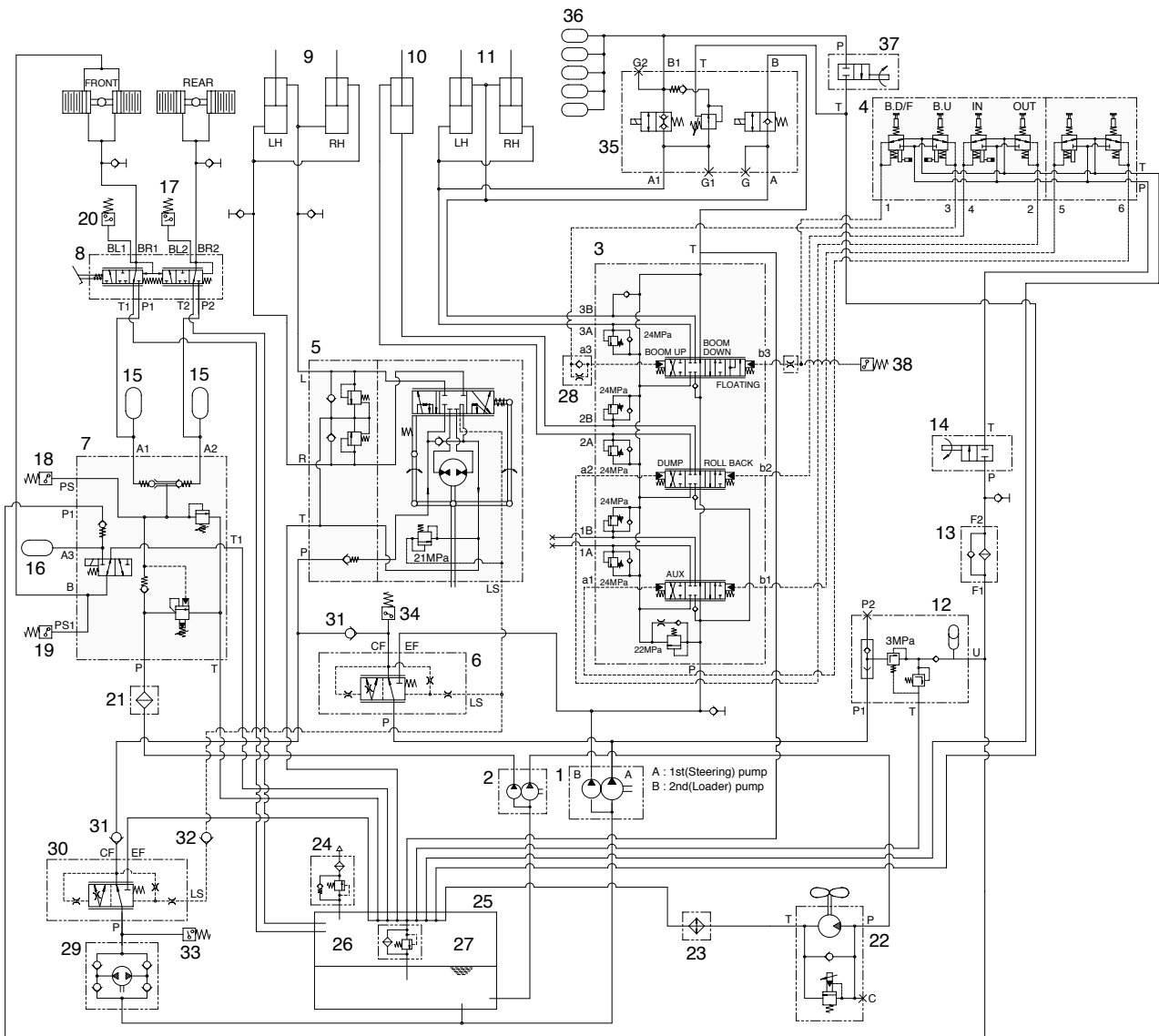

7407WE01

- | | | | | | |
|----|----------------------|----|-----------------|----|------------------------------|
| 1 | Main pump | 14 | Safety valve | 27 | By pass valve |
| 2 | Fan+Brake pump | 15 | Accumulator | 28 | Shockless valve |
| 3 | Main control valve | 16 | Accumulator | 29 | Emergency pump kit(Optional) |
| 4 | Remote control valve | 17 | Pressure switch | 30 | Priority valve(Optional) |
| 5 | Steering unit | 18 | Pressure switch | 31 | Check valve(Optional) |
| 6 | Priority valve | 19 | Pressure switch | 32 | Check valve(Optional) |
| 7 | Cut off valve | 20 | Pressure switch | 33 | Pressure switch(Optional) |
| 8 | Brake valve | 21 | Line filter | 34 | Pressure switch(Optional) |
| 9 | Steering cylinder | 22 | Fan drive motor | 35 | Ride control valve(Optional) |
| 10 | Bucket cylinder | 23 | Oil cooler | 36 | Accumulator(Optional) |
| 11 | Boom cylinder | 24 | Air breather | 37 | Safety valve(Optional) |
| 12 | Pilot supply unit | 25 | Hydraulic tank | 38 | Pressure switch(Optional) |
| 13 | Line filter | 26 | Return filter | | |

HYDRAULIC CIRCUIT(HL740TM-7)

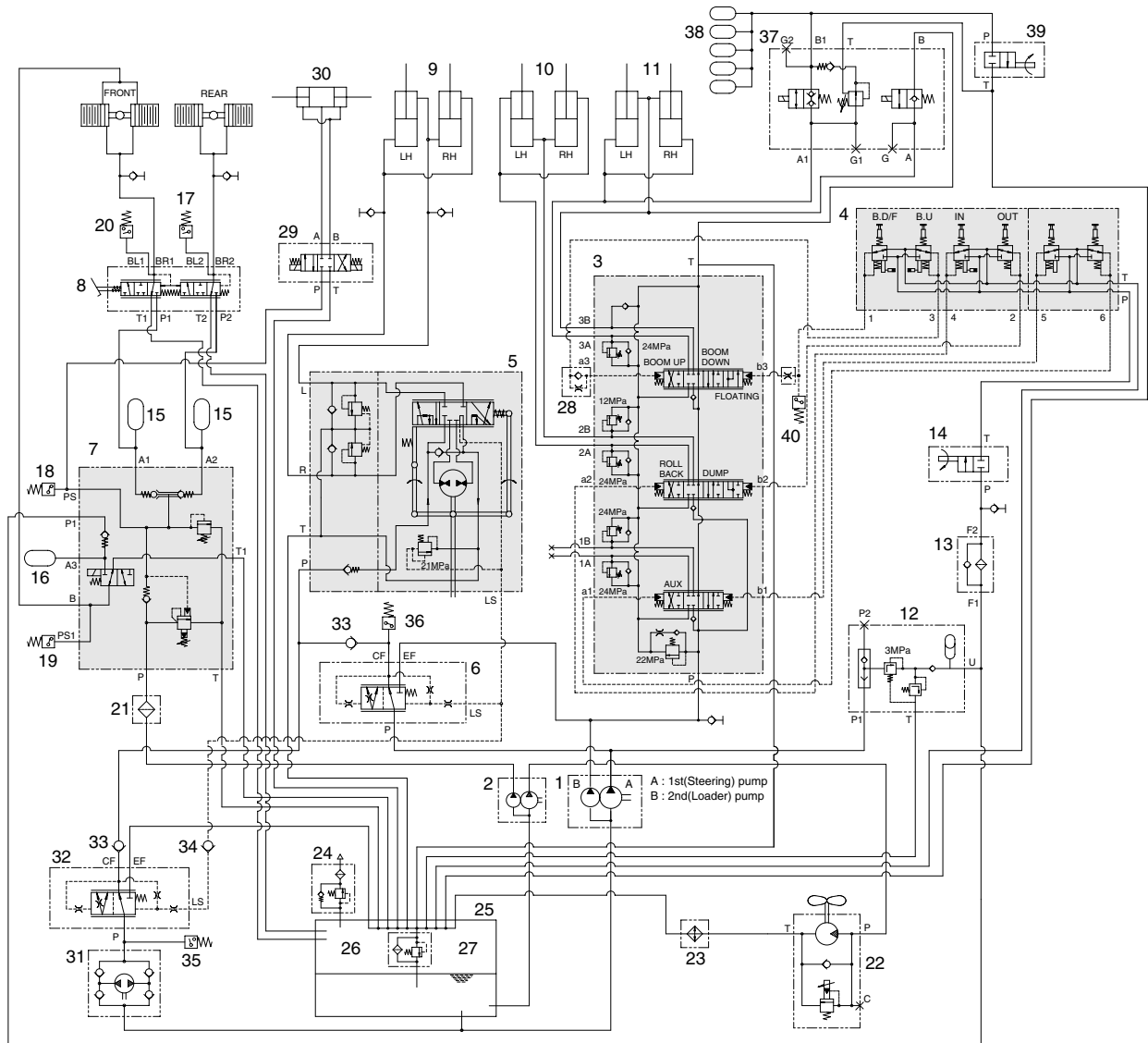

7407WE02

- | | | | | | |
|----|----------------------|----|-----------------|----|------------------------------|
| 1 | Main pump | 15 | Accumulator | 28 | Shockless valve |
| 2 | Fan+Brake pump | 16 | Accumulator | 29 | Solenoid valve |
| 3 | Main control valve | 17 | Pressure switch | 30 | Quick coupler cylinder |
| 4 | Remote control valve | 18 | Pressure switch | 31 | Emergency pump kit(Optional) |
| 5 | Steering unit | 19 | Pressure switch | 32 | Priority valve(Optional) |
| 6 | Priority valve | 20 | Pressure switch | 33 | Check valve(Optional) |
| 7 | Cut off valve | 21 | Line filter | 34 | Check valve(Optional) |
| 8 | Brake valve | 22 | Fan motor | 35 | Pressure switch(Optional) |
| 9 | Steering cylinder | 23 | Oil cooler | 36 | Pressure switch(Optional) |
| 10 | Bucket cylinder | 24 | Air breather | 37 | Ride control valve(Optional) |
| 11 | Boom cylinder | 25 | Hydraulic tank | 38 | Accumulator(Optional) |
| 12 | Pilot supply unit | 26 | Return filter | 39 | Safety valve(Optional) |
| 13 | Line filter | 27 | By pass valve | 40 | Pressure switch(Optional) |
| 14 | Safety valve | | | | |

3. WORK EQUIPMENT HYDRAULIC CIRCUIT

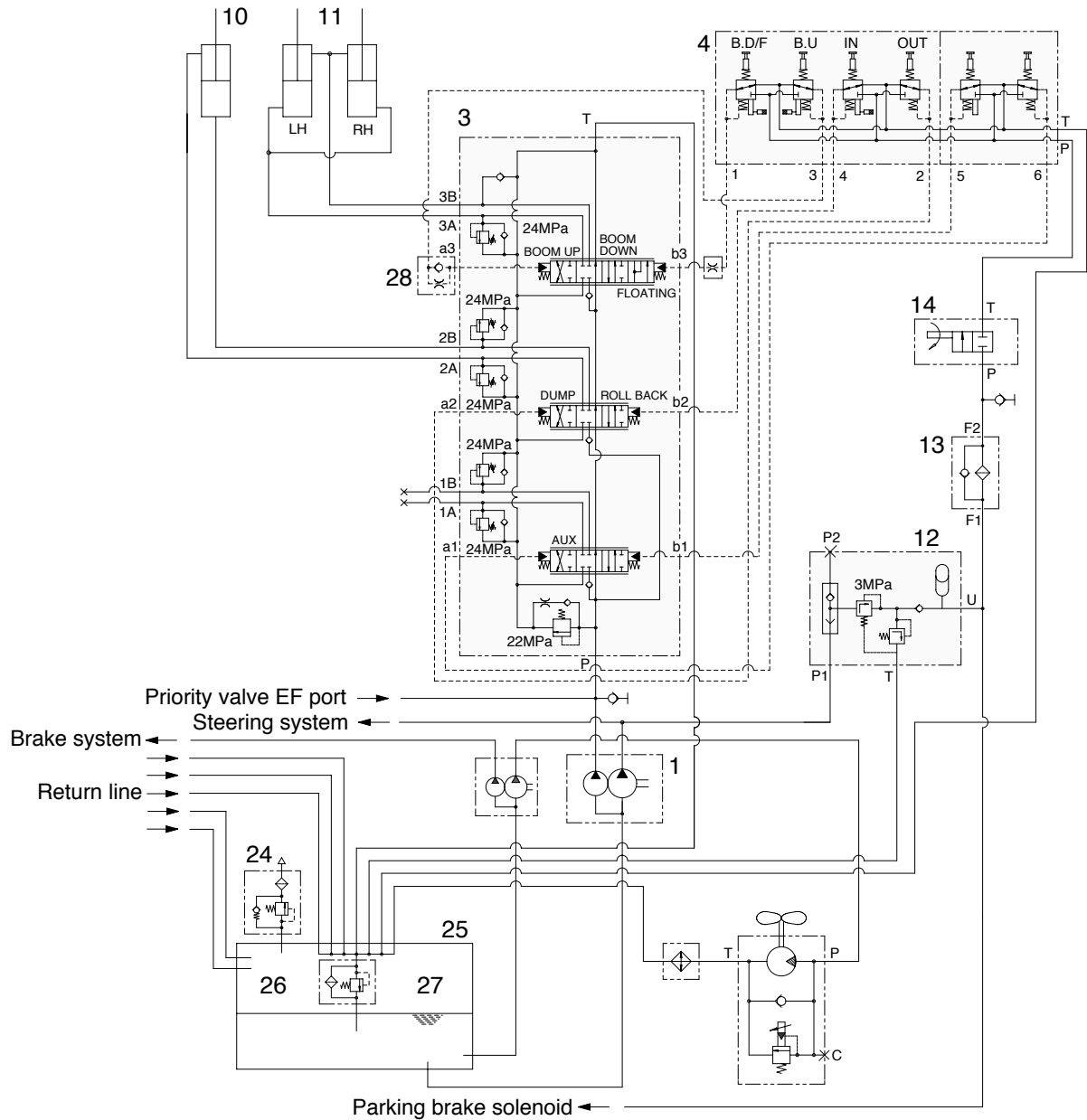

7407WE03

- | | | | | | |
|----|----------------------|----|-------------------|----|-----------------|
| 1 | Main pump | 12 | Pilot supply unit | 25 | Hydraulic tank |
| 3 | Main control valve | 13 | Line filter | 26 | Return filter |
| 4 | Remote control valve | 14 | Safety valve | 27 | Bypass valve |
| 10 | Bucket cylinder | 24 | Air breather | 28 | Shockless valve |
| 11 | Boom cylinder | | | | |

1) WHEN THE RCV LEVER IS IN THE RAISE POSITION

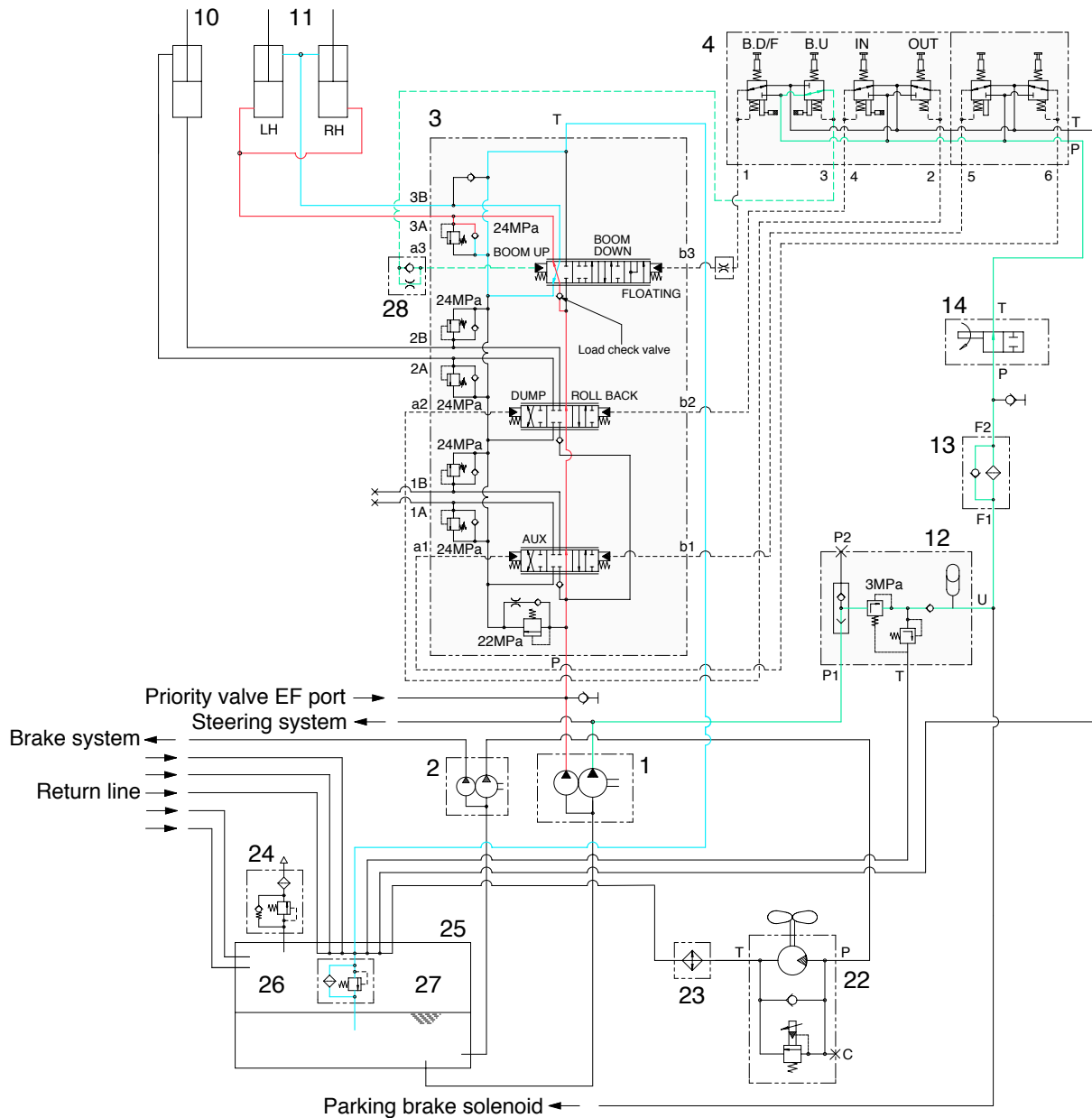

7407WE04

When the RCV lever(4) is pulled back, the boom spool is moved to raise position by pilot oil pressure from port 3 of RCV through shockless valve(28).

The oil from main pump(1) flows into main control valve(3) and then goes to the large chamber of boom cylinder (11) by pushing the load check valve of the boom spool through center bypass circuit of the bucket spool.

The oil from the small chamber of boom cylinder(11) returns to hydraulic oil tank(25) through the boom spool at the same time.

When this happens, the boom goes up.

2) WHEN THE RCV LEVER IS IN THE LOWER POSITION

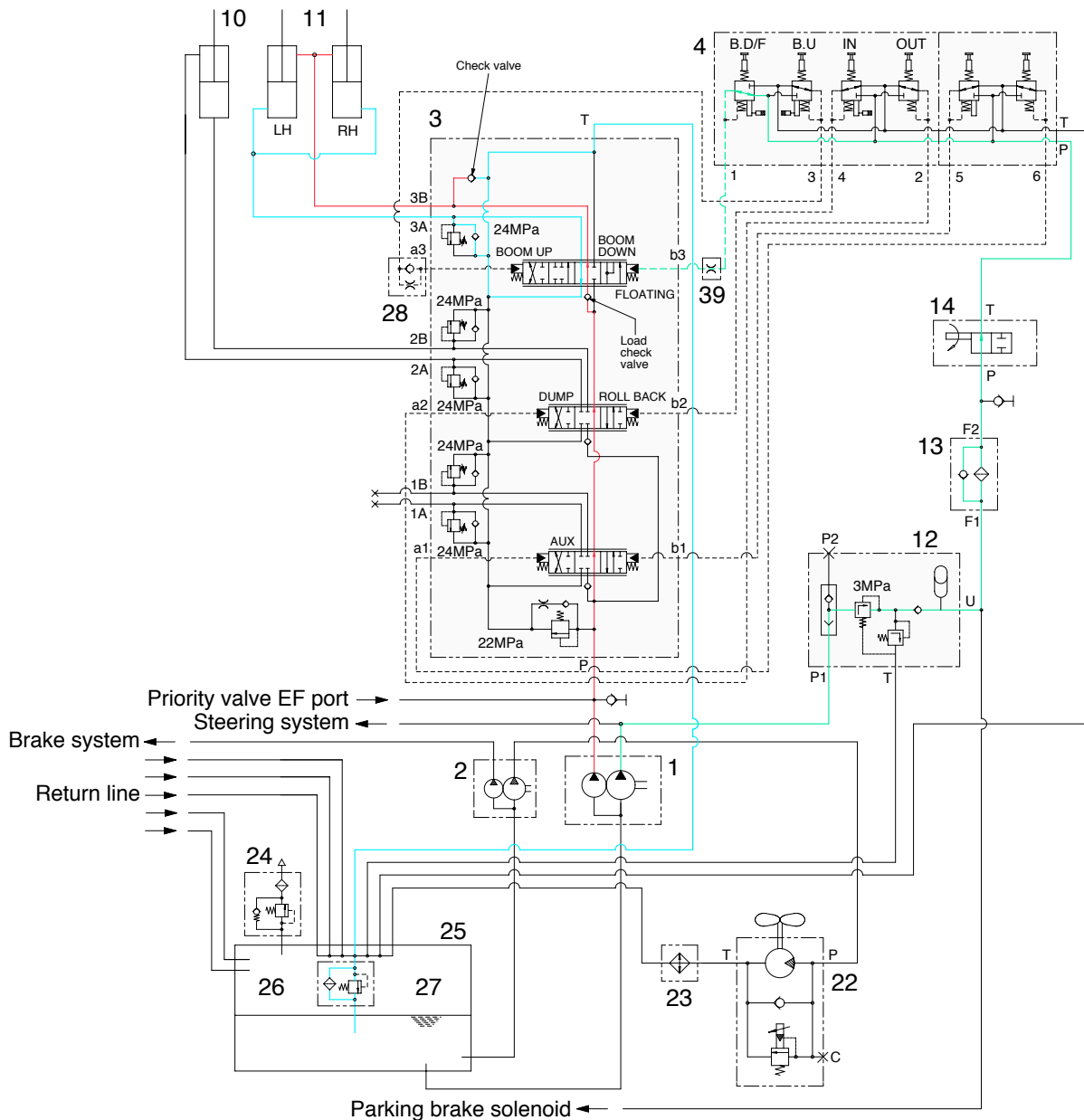

7407WE05

When the RCV lever(3) is pushed forward, the boom spool is moved to lower position by pilot pressure from port 1 of RCV through orifice connector(39).

The oil from main pump(1) flows into main control valve and then goes to small chamber of boom cylinder(11) by pushing the load check valve of the boom spool through center bypass circuit of the bucket spool.

The oil returned from large chamber of boom cylinder(11) returns to hydraulic tank(25) through the boom spool at the same time.

When the lowering speed of boom is faster, the return oil from the large chamber of boom cylinder combines with the oil from the pump through the check valve, and flows into the small chamber of the cylinder.

This prevents cylinder cavitation by the negative pressure when the pump flow cannot match the boom down speed.

3) WHEN THE RCV LEVER IS IN THE FLOAT POSITION

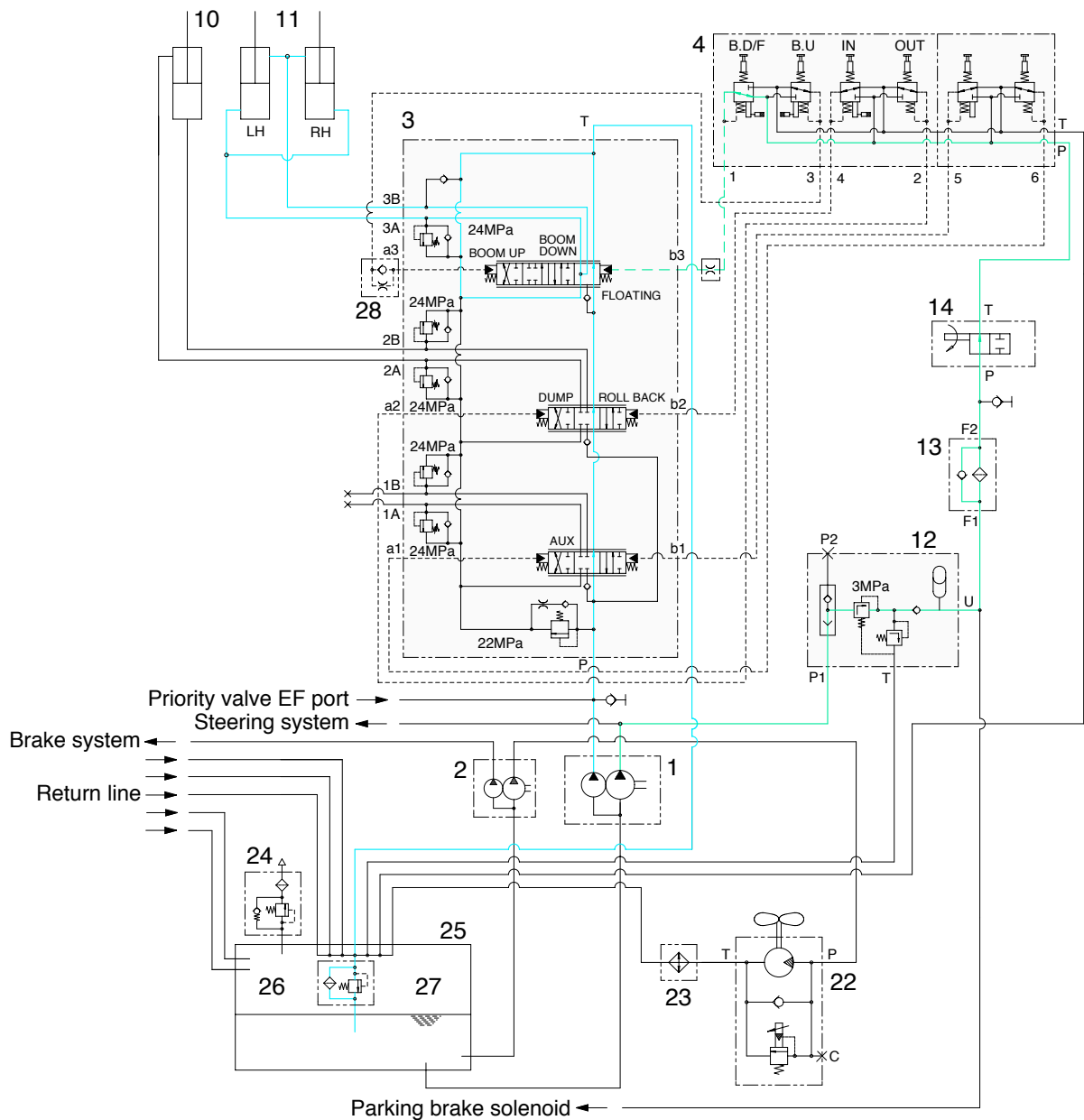

7407WE06

When the RCV lever(4) is pushed further forward from the lower position, the pilot pressure reaches to 13-15 bar, then the boom spool is moved to floating position.

The work ports(3A), (3B) and the small chamber and the large chamber are connected to the return passage, so the boom will be lowered due to it's own weight.

In this condition, when the bucket is in contact with the ground, it can be move up and down in accordance with the shape of the ground.

4) WHEN THE RCV LEVER IS IN THE DUMP POSITION

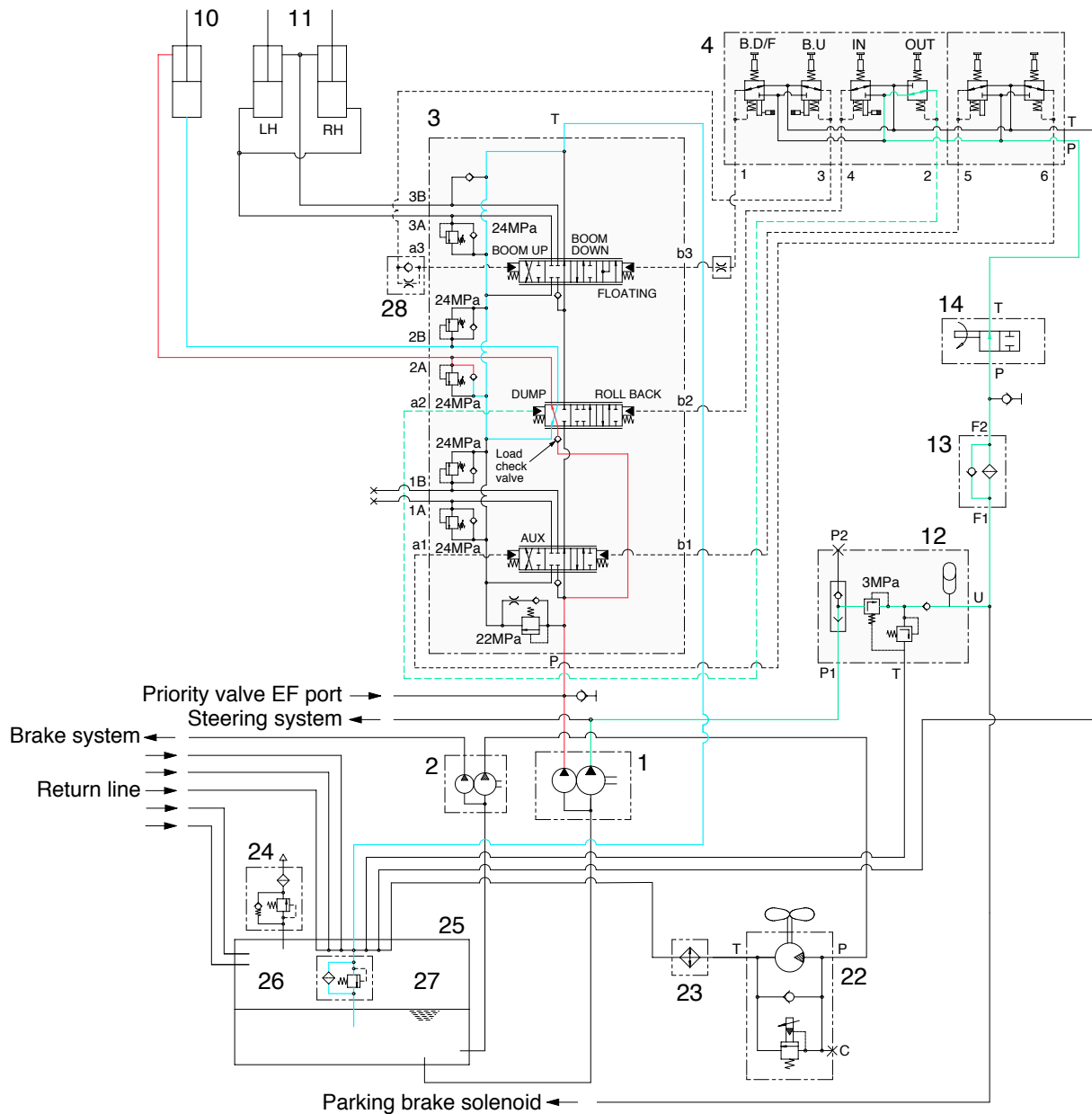

7407WE07

If the RCV lever(4) is pushed right, the bucket spool is moved to dump position by pilot oil pressure from port 2 of RCV.

The oil from main pump(1) flows into main control valve(3) and then goes to the small chamber of bucket cylinder(10) by pushing the load check valve of the bucket spool.

The oil at the large chamber of bucket cylinder(10) returns to hydraulic tank(25) through the bucket spool.

When this happens, the bucket is dumped.

When the dumping speed of bucket is faster, the oil returned from the large chamber of bucket cylinder combines with the oil from the pump, and flows into the small chamber of the cylinder.

This prevents cylinder cavitation by the negative pressure when the pump flow cannot match the bucket dump speed.

5) WHEN THE RCV LEVER IS IN THE ROLL BACK(retract) POSITION

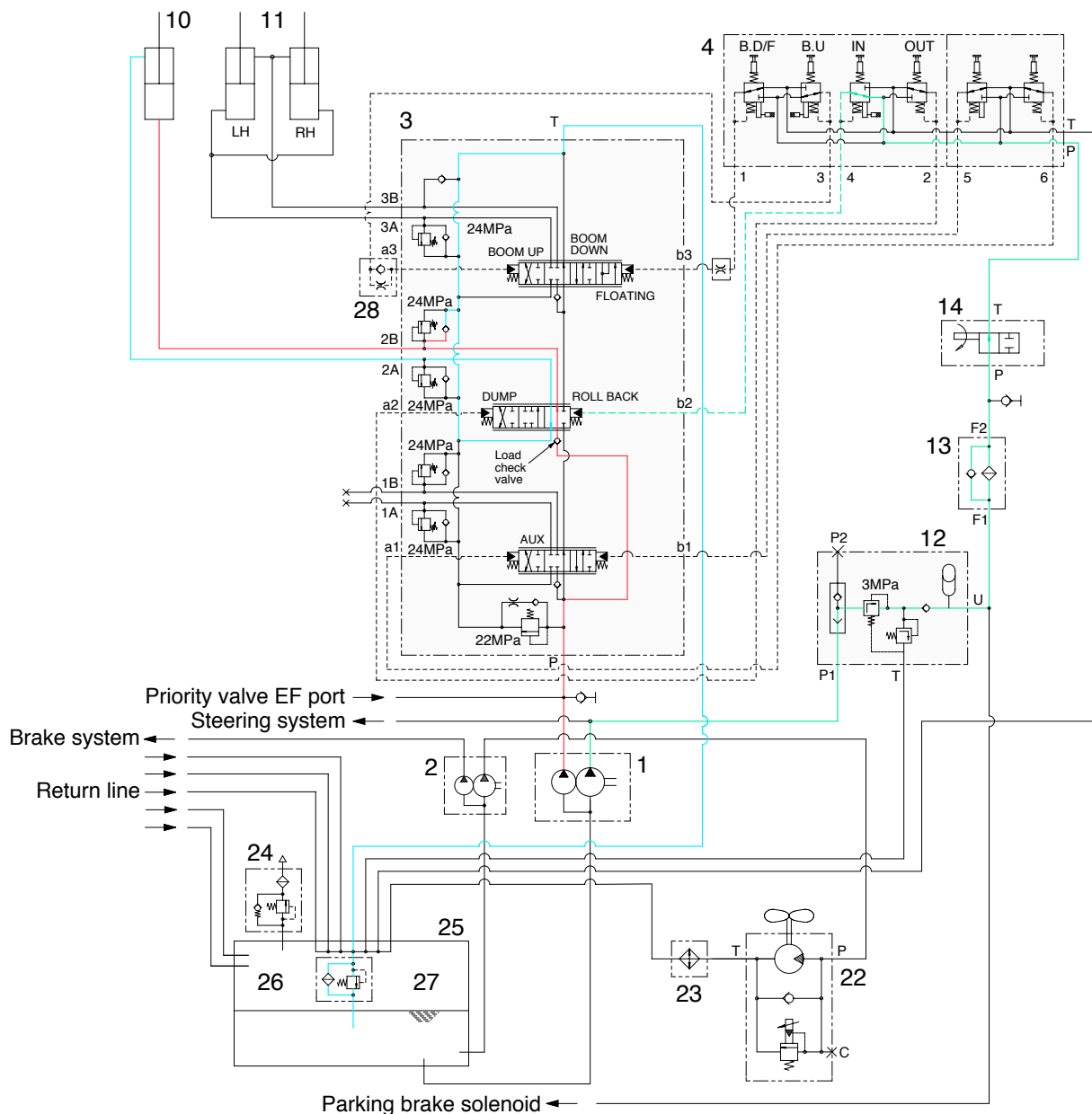

7407WE08

If the RCV lever(4) is pulled left, the bucket spool is moved to roll back position by pilot oil pressure from port 4 of RCV.

The oil from main pump(1) flows into main control valve(3) and then goes to the large chamber of bucket cylinder by pushing the load check valve of the bucket spool.

The oil at the chamber of bucket cylinder(10) returns to hydraulic tank(25) through the bucket spool. When this happens, the bucket roll back.

When the rolling speed of bucket is faster, the return oil from the small chamber of bucket cylinder combines with the oil from the pump, and flows into the large chamber of the cylinder.

This prevents cylinder cavitation by the negative pressure when the pump flow cannot match the bucket rolling speed.

6) WHEN THE RCV LEVER IS IN THE HOLD POSITION

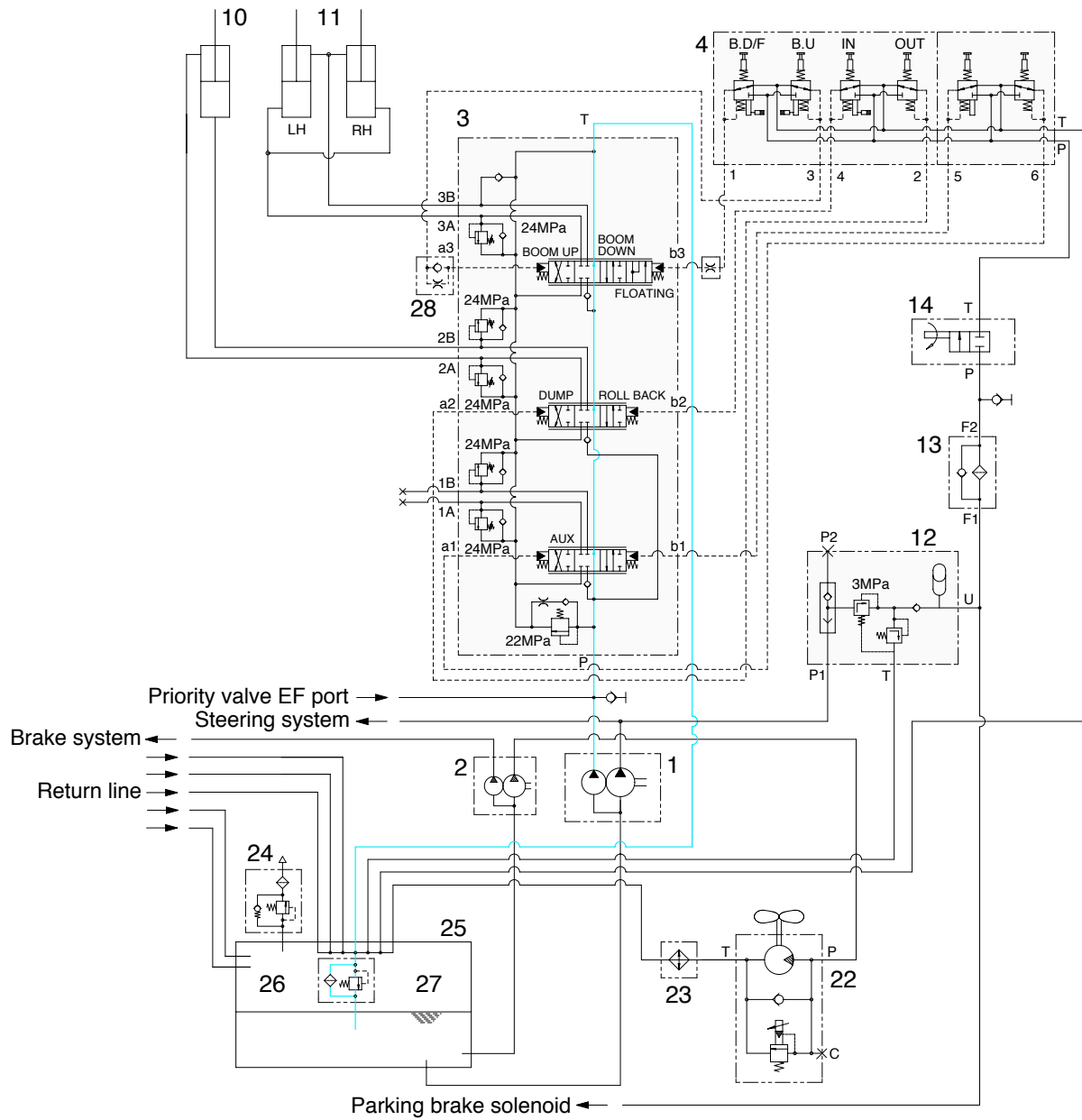

7407WE09

The oil from main pump(1) flows into main control valve(3).

In this time, the bucket spool and the boom spool are in neutral position, then the oil supplied to main control valve(3) returns into hydraulic tank(25) through center bypass circuit of each spool.

In this condition, each cylinder keeps the neutral position, so the boom and the bucket is held.

4. MAIN PUMP OPERATION

1) STRUCTURE

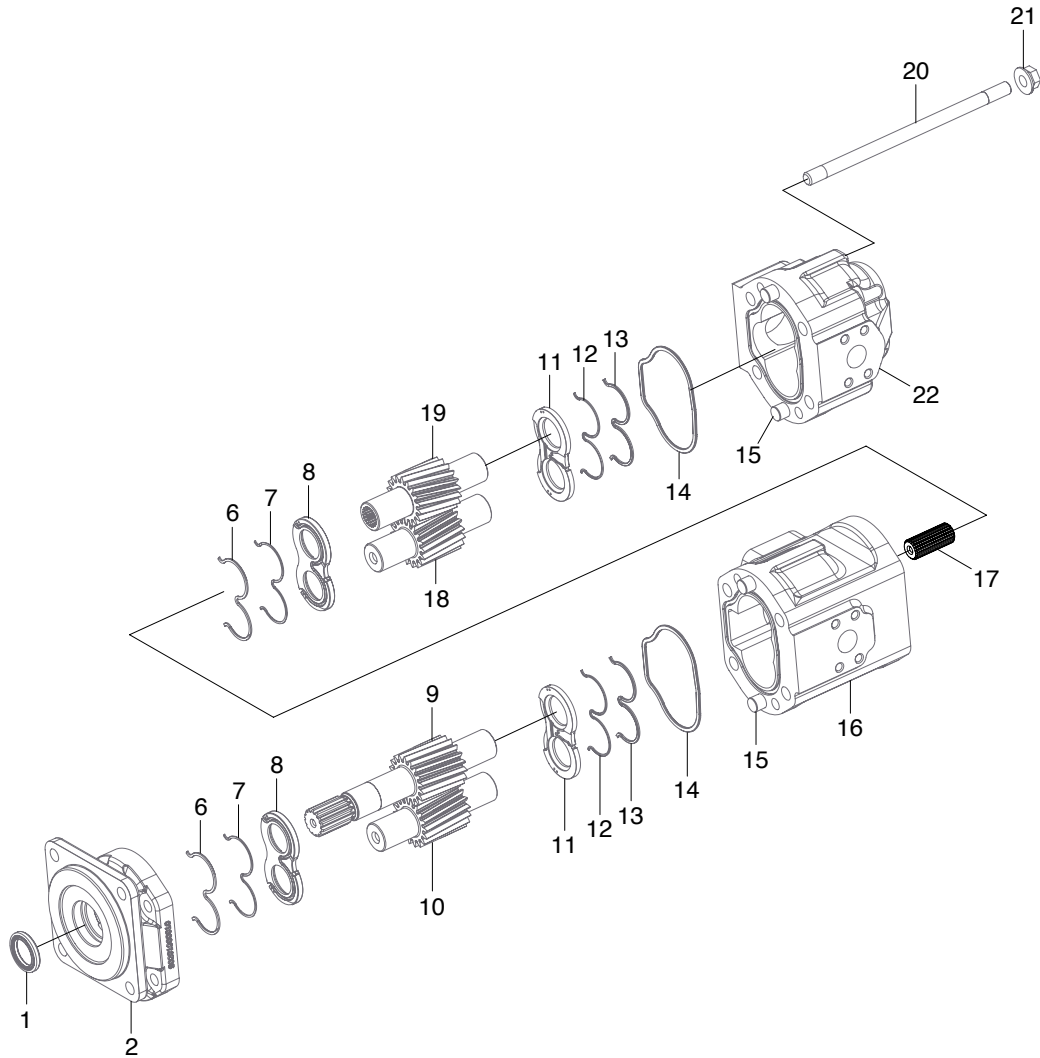

7407WE12

- | | | | | | |
|----|-------------------|----|----------------|----|------------------|
| 1 | Shaft seal | 11 | Wearplate | 17 | Spline coupling |
| 2 | Adapter | 12 | O-ring seal | 18 | Rear driven gear |
| 6 | Back up seal | 13 | Back up seal | 19 | Rear drive gear |
| 7 | O-ring seal | 14 | Interface seal | 20 | Stud |
| 8 | Wearplate | 15 | Dowel | 21 | Flanged nut |
| 9 | Front drive gear | 16 | Front body | 22 | Rear body |
| 10 | Front driven gear | | | | |

2) OPERATION

The main hydraulic pump is a fixed displacement helical gear type pump. The pump is drive at engine speed by the transmission. The pump shafts are supported by shaft seal(1) adapter(2), front body(16) and rear body(22). The wearplate(8, 11) are located between the gear surface and adapter(1), rear body(22) and front body(16).

As the drive gear(9) and (19) turns the idler gears(10, 18), the gear teeth come out of mesh. Oil flows from the hydraulic tank through the inlet into the cavity between the gear teeth. As the gears continue to rotate, the oil becomes trapped between the gear teeth and front body(16).

The trapped oil is the oil is then carried to the pump outlet. Oil is forced out the outlet to supply the hydraulic function. As the gears re-mesh, they form a seal to prevent oil from flowing between the gears and back to the inlet.

The pump uses outlet pressure oil to load the wearplate(8, 11) against the gear faces. This controls internal leakage to maintain pump displacement.

Outlet pressure fills the area bounded by the pressure balance moulded seals(6, 7) to force the wearplate against the high pressure area or the gear faces.

5. REMOTE CONTROL VALVE

1) STRUCTURE

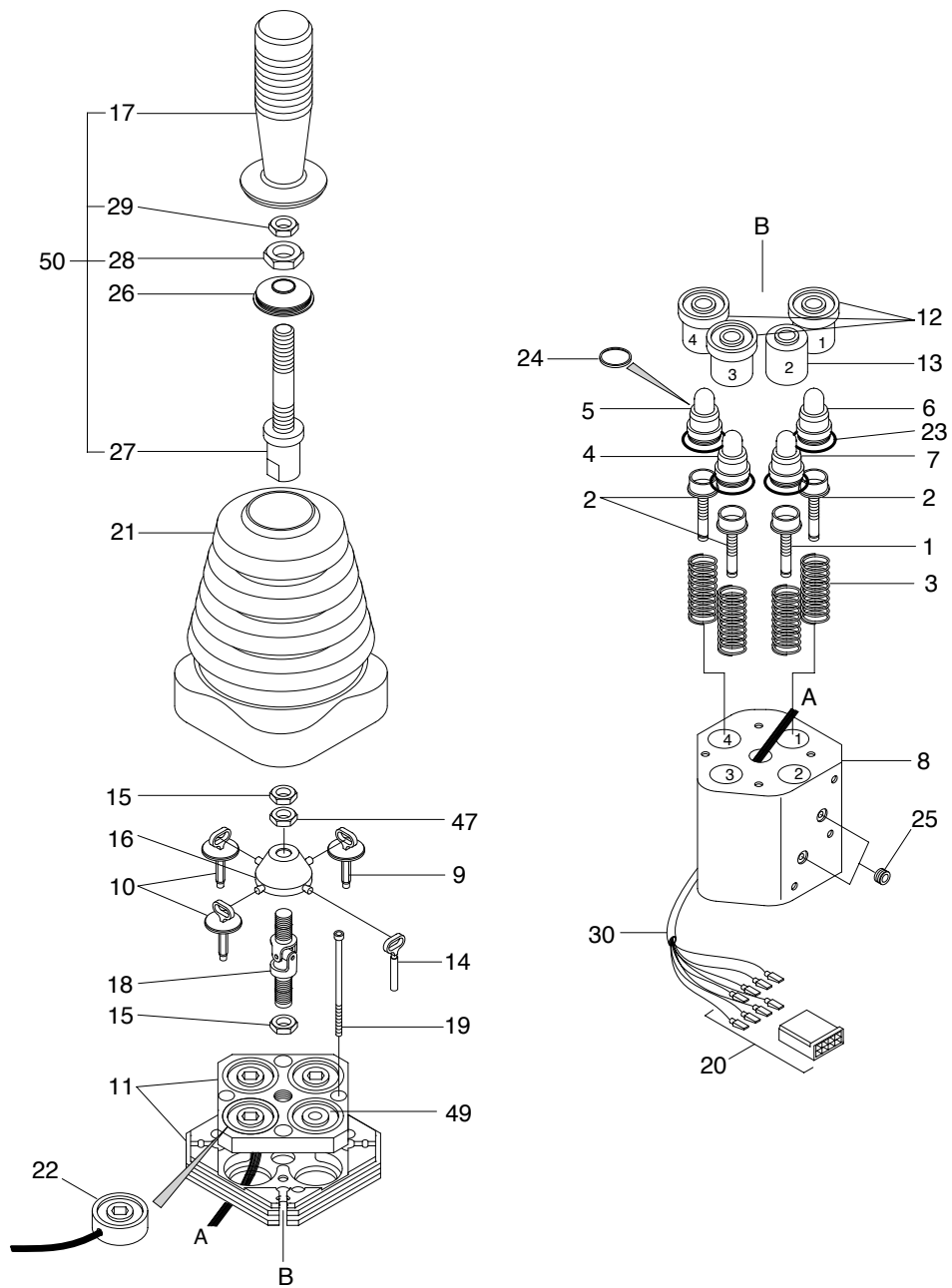

- | | | | | | |
|----|--------------|----|----------------------|----|-----------------|
| 1 | Spring pack | 12 | Prefeel cage assy | 23 | O-ring |
| 2 | Spring pack | 13 | Spindle retainer | 24 | Wiper seal |
| 3 | Spring | 14 | Spindle | 25 | Plug |
| 4 | Plunger assy | 15 | Nut | 26 | Collar |
| 5 | Plunger assy | 16 | Lever assy | 27 | Handle adapter |
| 6 | Plunger assy | 17 | Handle | 28 | Nut |
| 7 | Plunger assy | 18 | Universal joint assy | 29 | Nut |
| 8 | Body | 19 | Screw | 30 | Insulation tube |
| 9 | Prefeel kit | 20 | Connector assy | 47 | Nut |
| 10 | Prefeel kit | 21 | Rubber boot | 49 | Spacer |
| 11 | Prefeel kit | 22 | Solenoid | 50 | Handle assy |

7403AWE11

2) OPERATION

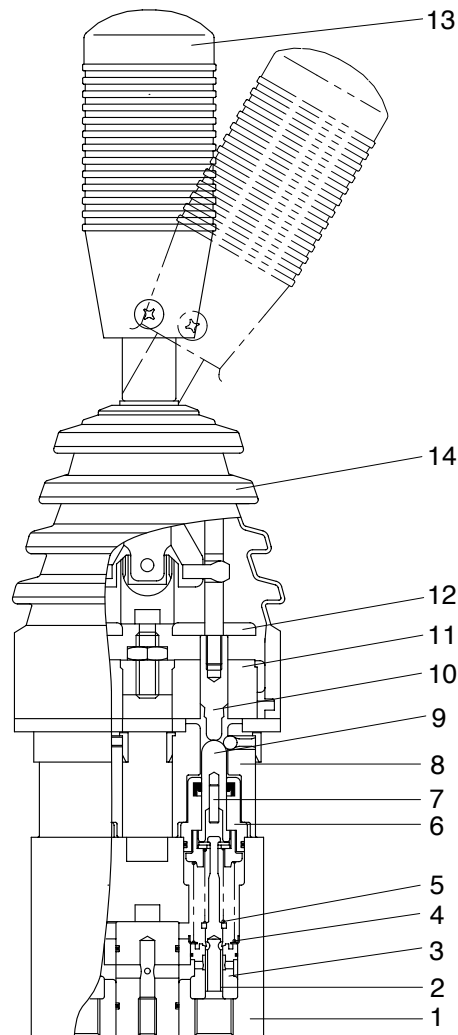

7406S 6-14A

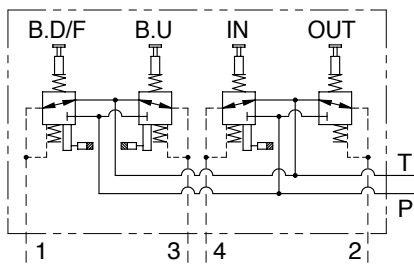

HYDRAULIC CIRCUIT

Port	Port name	Port size
1	Boom down	1/4 BSPP
2	Bucket dump	1/4 BSPP
3	Boom raise	1/4 BSPP
4	Bucket crowd	1/4 BSPP
P	Supply pressure	1/4 BSPP
T	Tank	1/4 BSPP

- | | | | | | |
|---|-------------------------|----|----------------------|----|----------------|
| 1 | Aluminum body | 6 | Plunger guide | 11 | Hold coil |
| 2 | Pressure reducing spool | 7 | Roll pin | 12 | Armature plate |
| 3 | Pressure reducing body | 8 | Prefeel ball carrier | 13 | Control lever |
| 4 | Return spring | 9 | Plunger | 14 | Rubber boot |
| 5 | Metering spring | 10 | Prefeel spindle | | |

(1) Neutral position

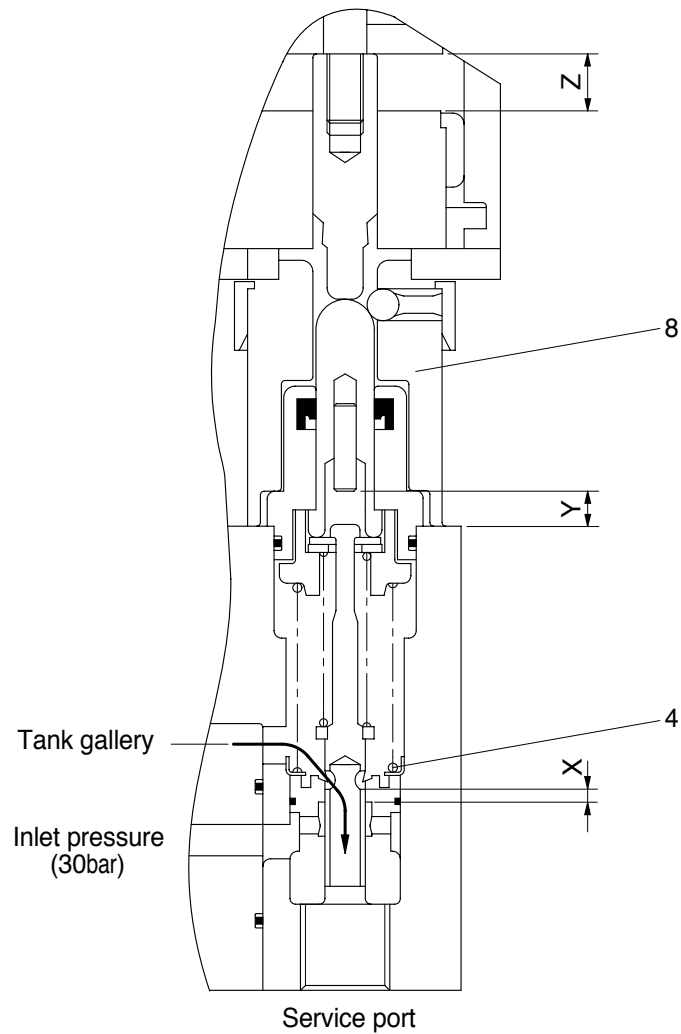

(740-3A) RCV01

The rubber boot(14) fitted between the control lever(13) and the valve protects the working parts from external contamination. The return spring(4) holds the plunger(8) in its most upwardly position keeping the lever vertical. In this position all four service ports are connected to the tank gallery and hence to the tank port.

(2) Metering position

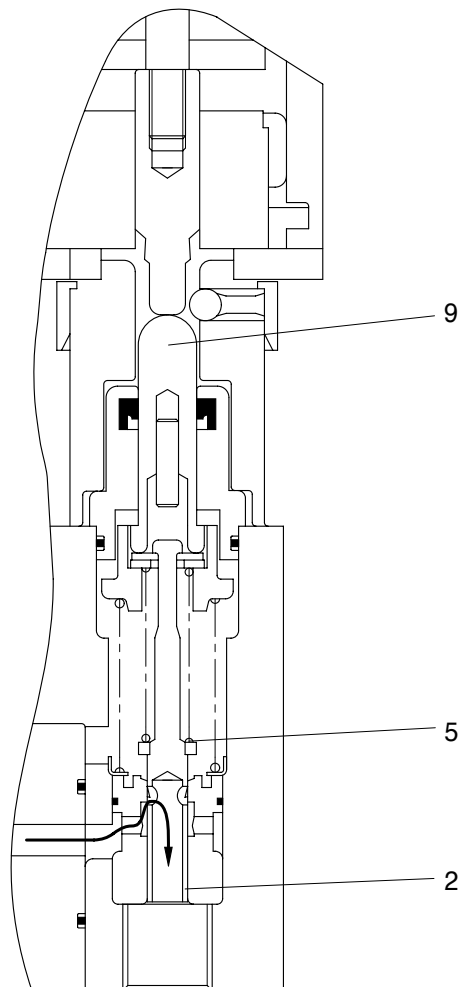

(740-3A) RCV03

By selecting the control lever(13) the plunger(9) is progressively selected until the spool(2) dead band X is taken up. During this interval the service port is still connected to the tank gallery. Any further selection of the control lever(13) will ;

Cause the four metering holes in the spool(2) to open slightly, allowing pressure to be raised at the service port. This increase in pressure then counteracts the load produced by the metering spring(5) closing off the opening until an equilibrium is maintained. The pressure raised at the service port is proportional to the rate of the metering spring. The initial jump in pressure is caused by the preload in the metering spring(5) and can be altered as required simply by adjusting the shimming.

Cause the service port to shut off to the rank gallery.

(3) End of metering

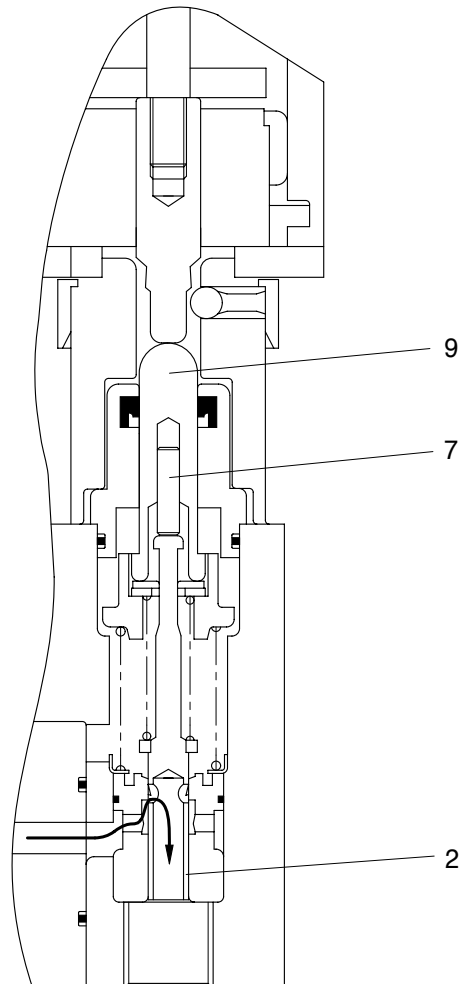

(740-3A) RCV04

After the plunger(9) has been displaced a distance of $X+Y$, the plunger roll pin(7) is just contacting the top of the spool(2). Any further selection of the control lever(13) will cause the four metering holes in the spool(2) to open independently of the pressure.

Thus any selection of the control lever(13) past $X+Y$ will cause the service pressure to increase immediately to inlet pressure.

(4) Fully selected

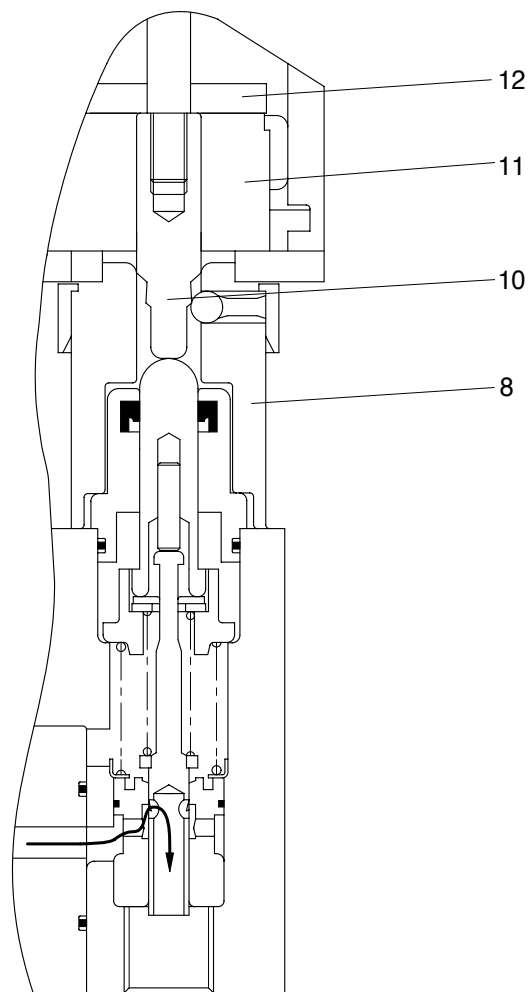

(740-3A) RCV05

Selecting the control lever(13) now will maintain the service port pressure at inlet until the armature plate(12) contacts on the hold coil(11). However, just prior to this, the ramp on the prefeel spindle(10) reacts against the three springs in the prefeel ball carrier(8).

This produces a sharp increase in operator load(Prefeel), ensuring that the service is not accidentally selected through to detent.

6. MAIN CONTROL VALVE

1) STRUCTURE

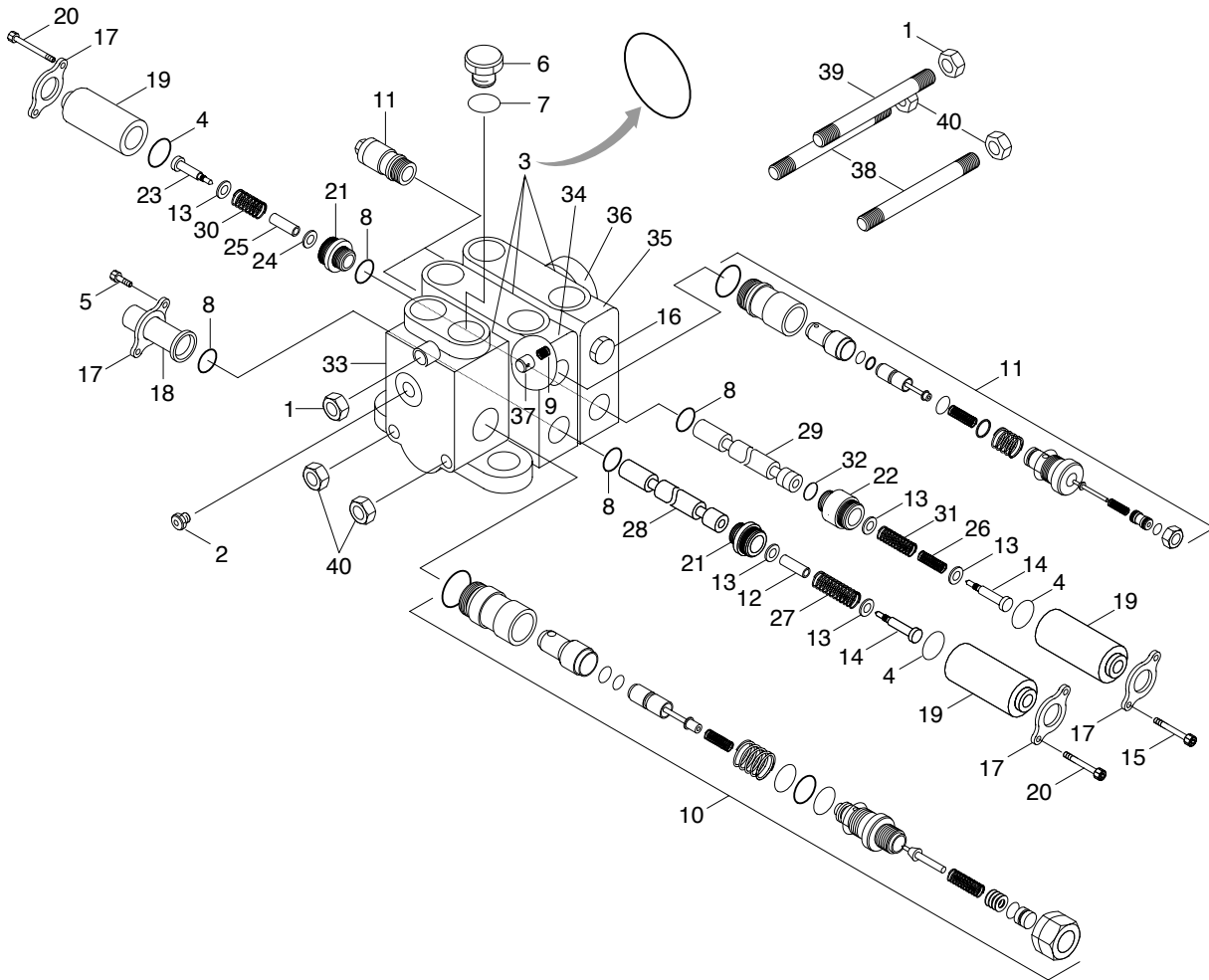

7403AWE12

1	Special nut	15	Cap screw	29	Spool
2	Plug	16	Anti void assy	30	Spring
3	O-ring	17	Retainer	31	Spring
4	O-ring	18	Spool cap	32	Back up ring
5	Cap screw	19	Spool cap	33	Inlet housing
6	Plug	20	Cap screw	34	Housing
7	O-ring	21	Retainer	35	Housing
8	O-ring	22	Retainer	36	Outlet housing
9	Spring	23	Shoulder screw	37	Poppet
10	Main relief valve	24	Flat washer	38	Tie rod
11	Port relief valve	25	Spacer	39	Tie rod
12	Spacer	26	Spring	40	Special nut
13	Flat washer	27	Spring		
14	Shoulder screw	28	Spool		

STRUCTURE

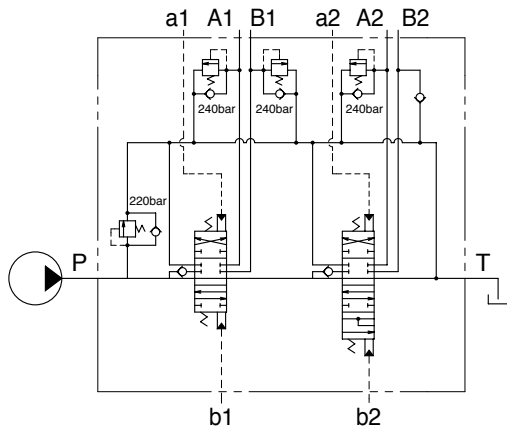
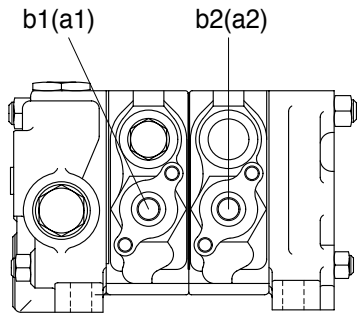
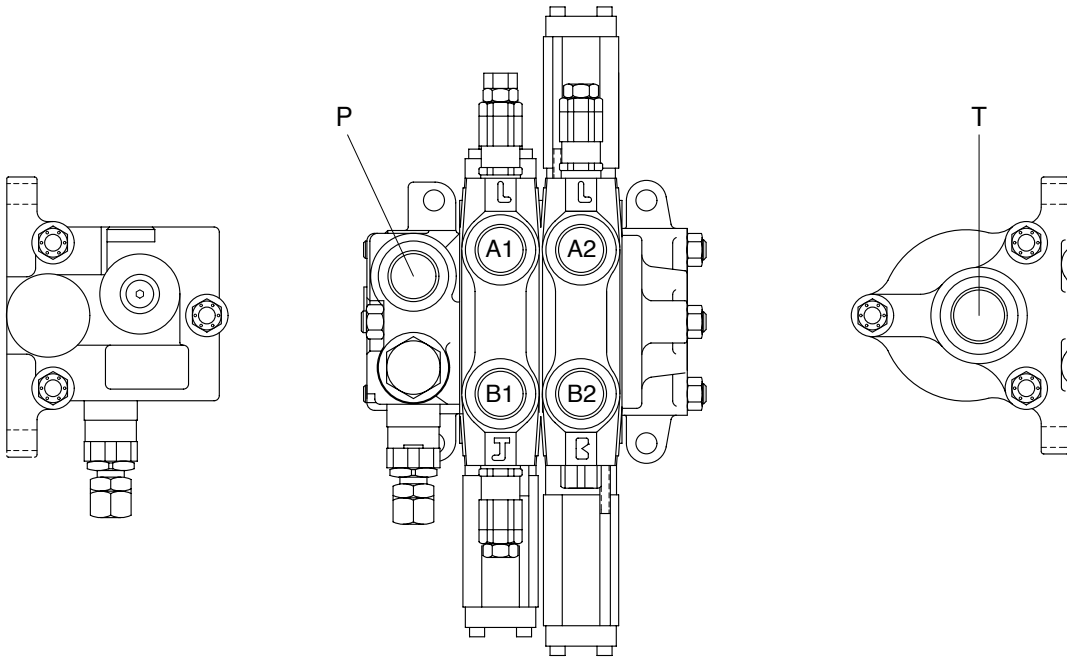

HYDRAULIC CIRCUIT

Port	Port name	Port size
P	From main pump	1 3/16-12UN
T	To hydraulic tank	1 5/16-12UN
A1, B1	To bucket cylinder port	1 3/16-12UN
A2, B2	To boom cylinder port	1 3/16-12UN
a1, b1	Bucket pilot port	9/16-18UNF
a2, b2	Boom pilot port	9/16-18UNF

2) BOOM SECTION OPERATION

(1) Spool in neutral

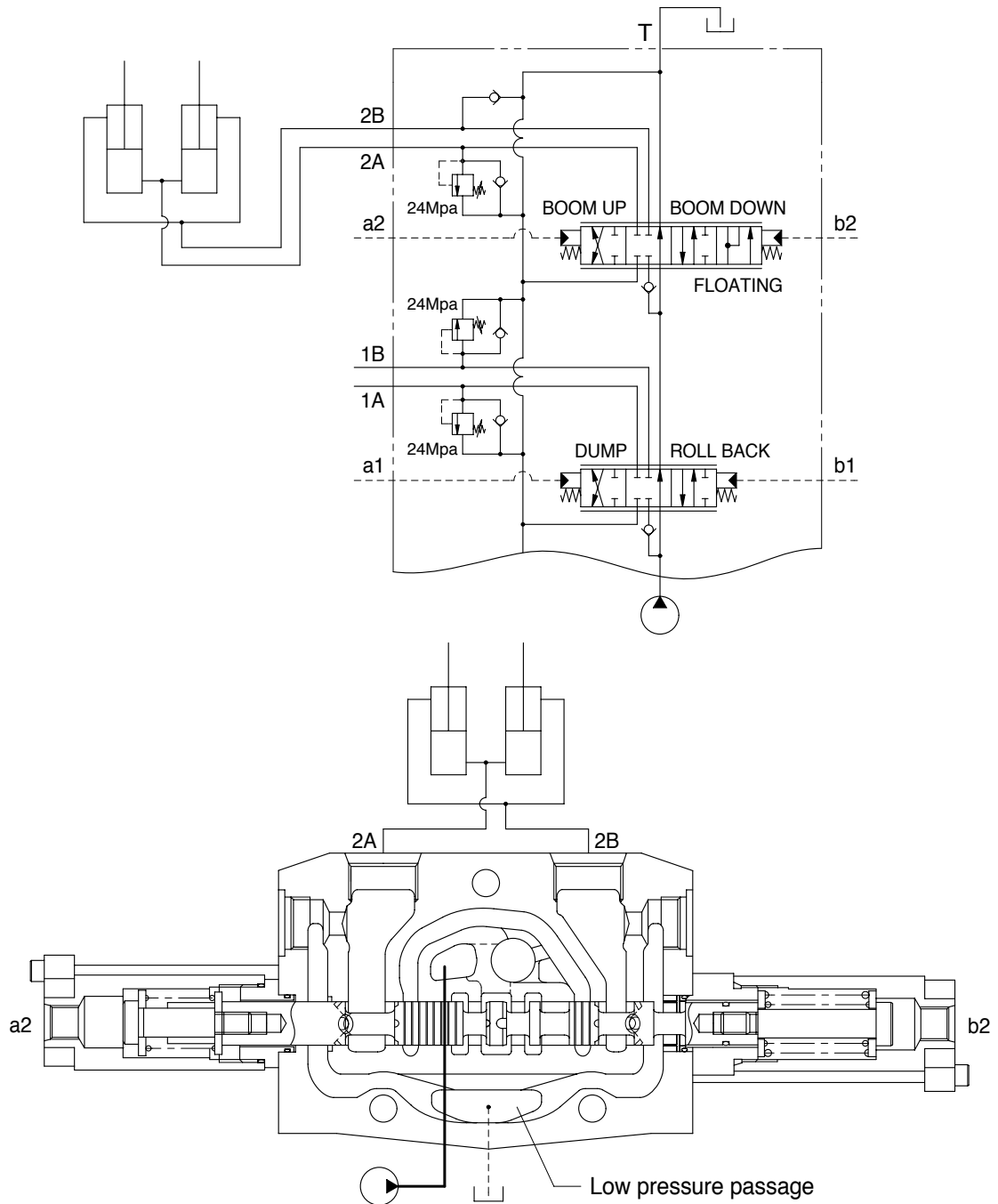

7406S6-18 21

If the remote control valve is not operated, the oil supplied from the pump port passes through the neutral passage to the low pressure passage at the outlet section, and then returns to the tank port.

(2) Boom raise position

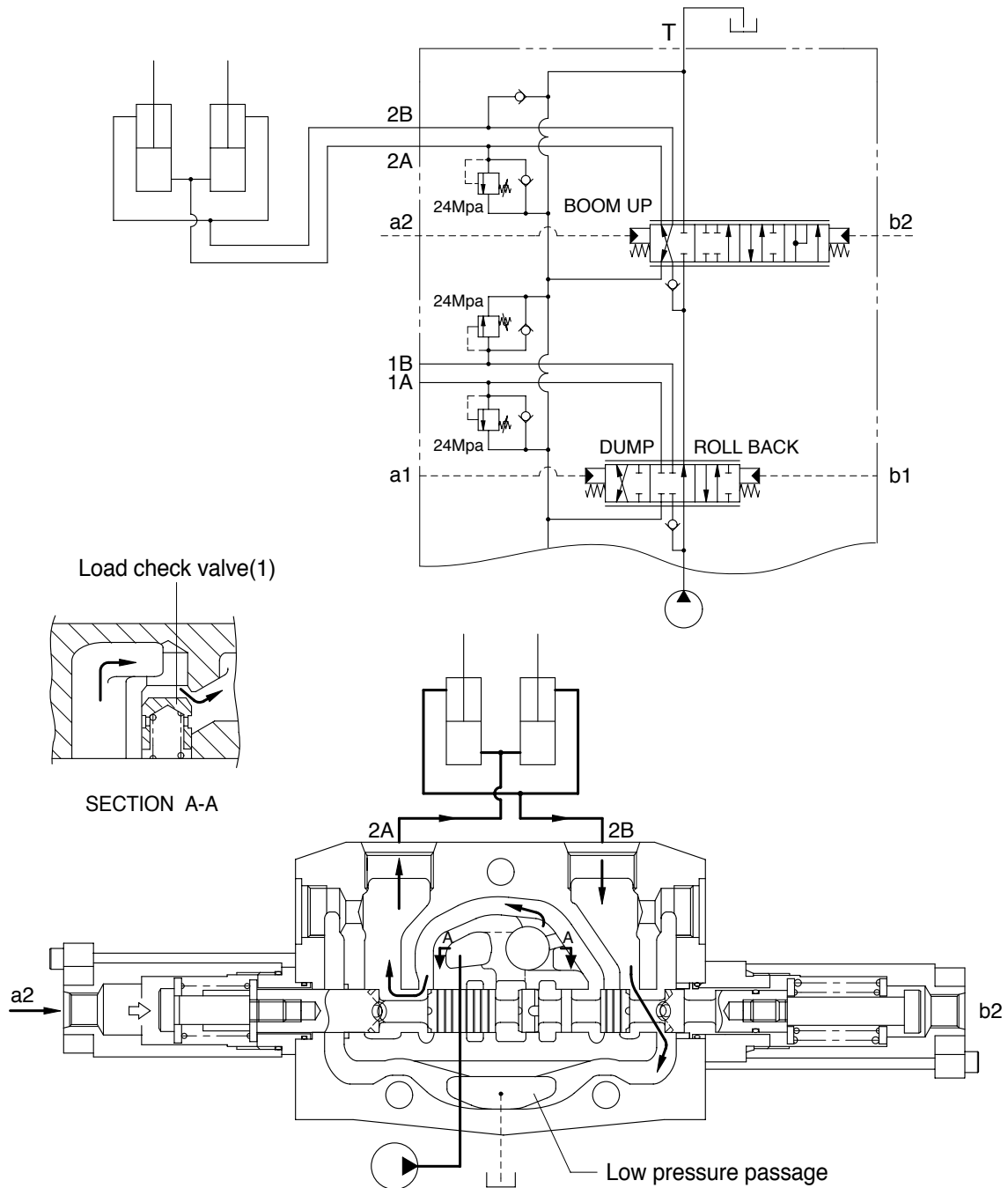

7406S6-19 22

When the pilot pressure from remote control valve is supplied to the pilot port(a2), the spool moves to the right and the neutral passage is closed.

The oil supplied from the pump pushes up the load check valve(1) and flow into boom cylinder port(2A). The pump pressure reaches proportionally the load of cylinder and fine control finished by shut off of the neutral passage.

The return oil from cylinder port(2B) flows into the tank via the low pressure passage.

(3) Boom lower position

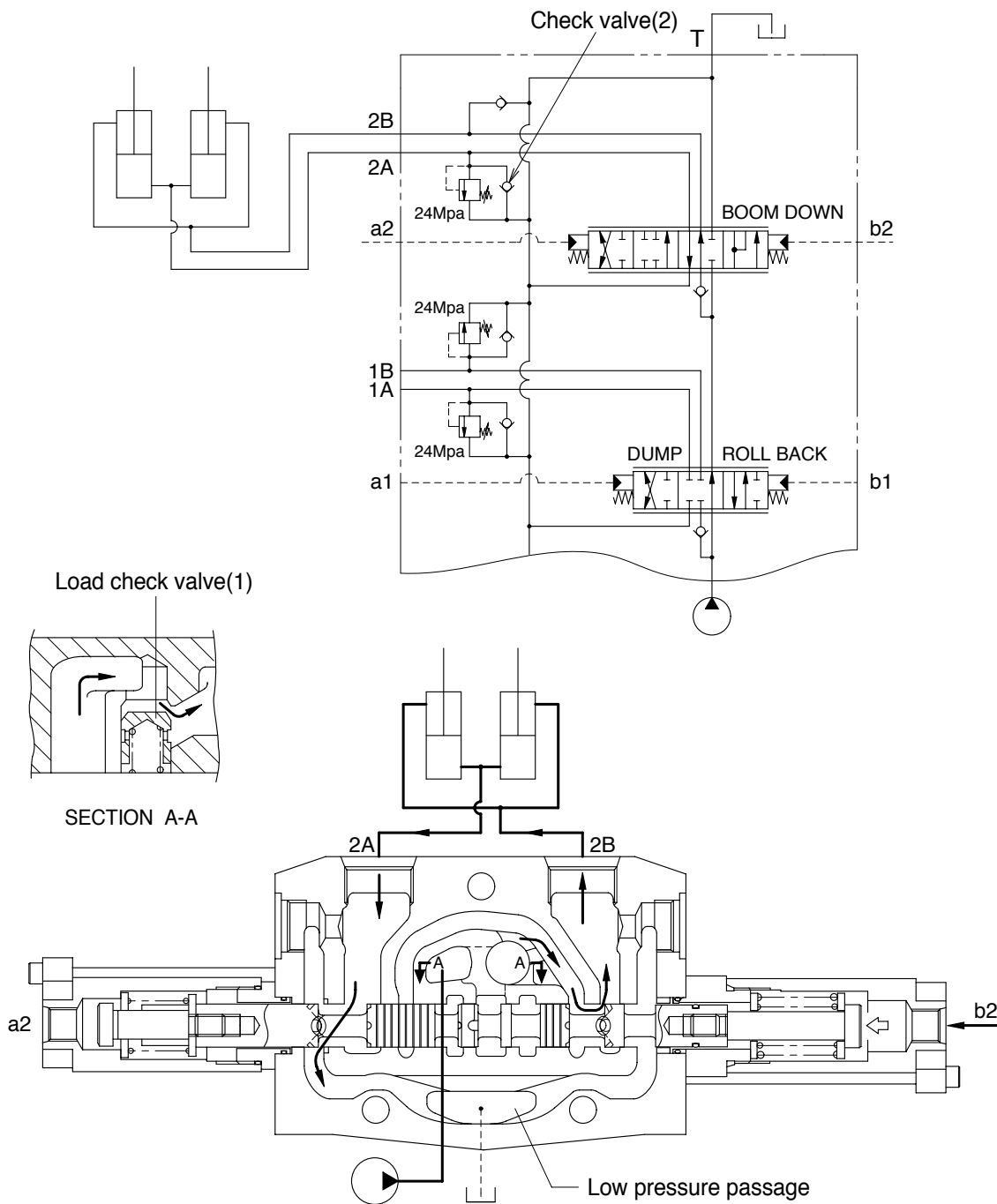

7406S6-20 23

When the pilot pressure from remote control valve is supplied to the pilot port(b2), the spool moves to the left and the neutral passage is closed.

The oil supplied from the pump pushes up the load check valve(1) and flow into boom cylinder port(2B). The pump pressure reaches proportionally the load of cylinder and fine control finished by shut off of the neutral passage.

The return oil from cylinder port(2A) flows into the tank via the low pressure passage.

When the lowering speed of boom is faster, the return oil from the large chamber of boom cylinder combines with the oil from the pump through the check valve(2), and flows into the small chamber of cylinder. This prevents cylinder cavitation by the negative pressure when the pump flow cannot match the boom lowering speed.

(4) Boom float position

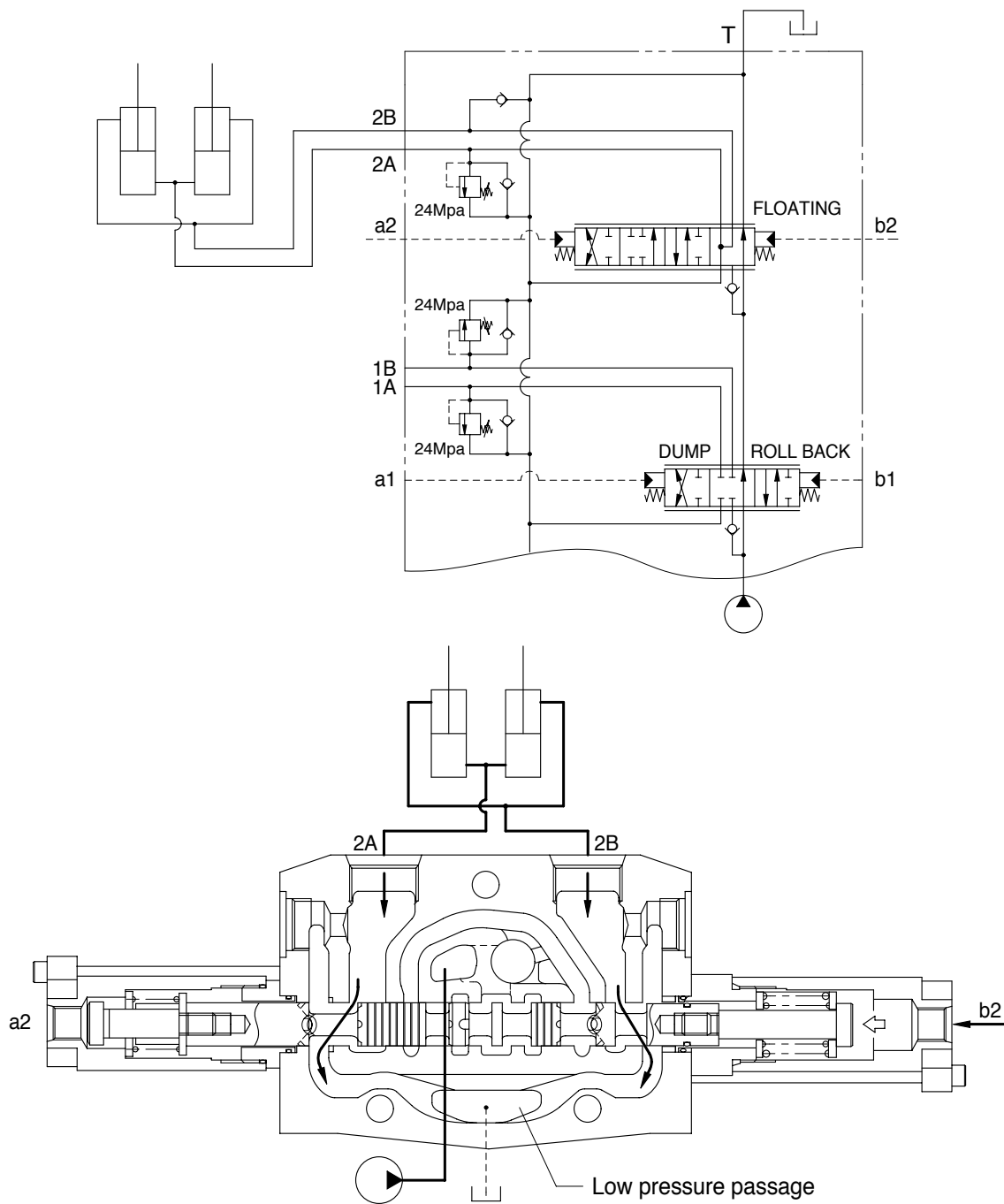

7406S6-21 24

If the remote control lever pushes further more, the pilot pressure from remote control valve rises over 13-15bar and then the boom lowering spool is pushed to the boom floating position, opening up the neutral passage to tank and simultaneously (2A), (2B) \uparrow T.

In float position the boom drops quickly due to its own weight.

When the bucket touches the ground and the wheeled loader is moving, the bucket raised or lowered following the unevenness of the ground due to the (2A), (2B) \uparrow T connecting.

3) BUCKET SECTION OPERATION

(1) Spool in neutral

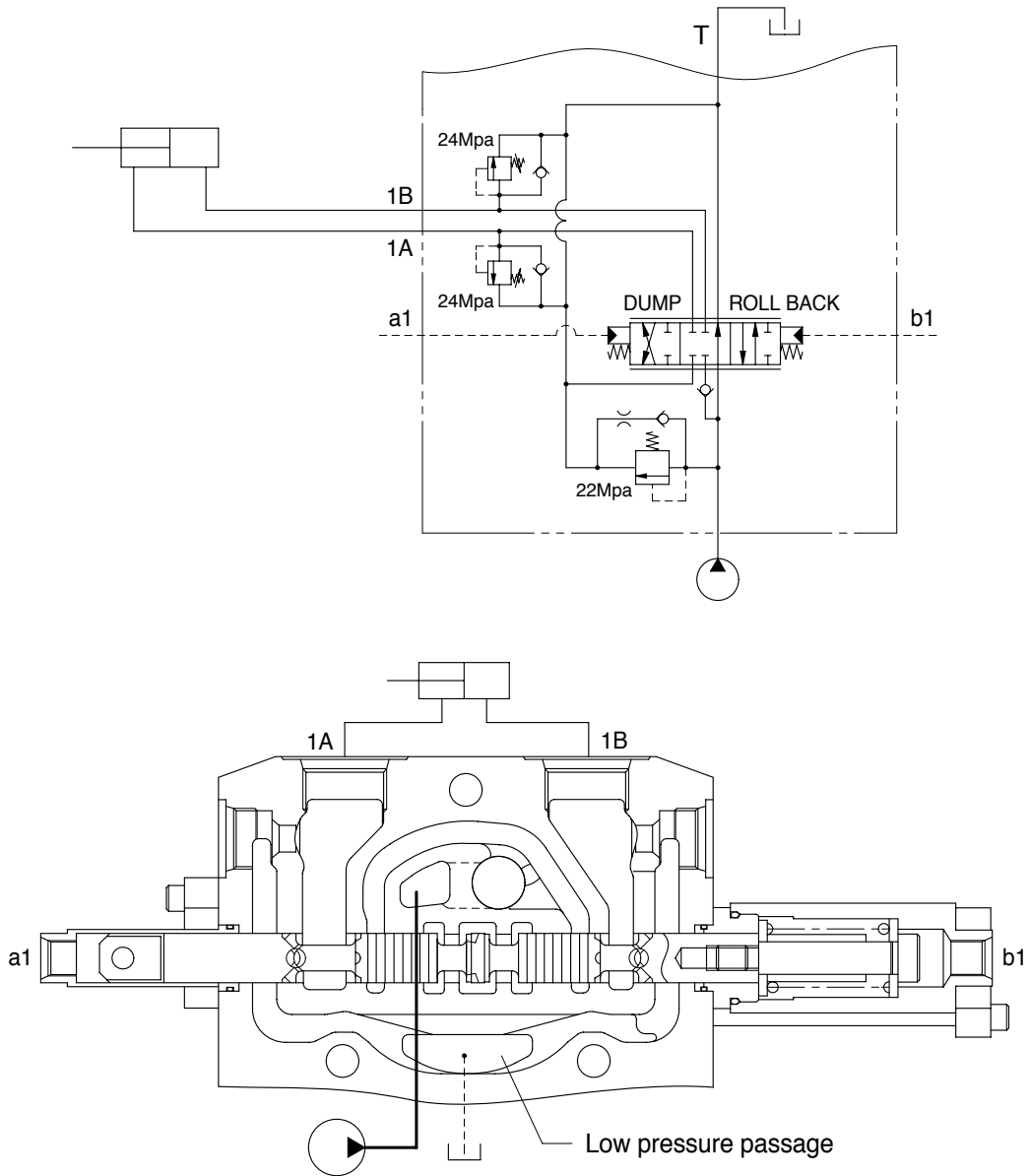

7406S 6-22 25

If the remote control valve is not operated, the oil supplied from the pump port passage through the neutral passage to the low pressure passage at the outlet section, and then return to the tank port.

(2) Retract(Roll back) position

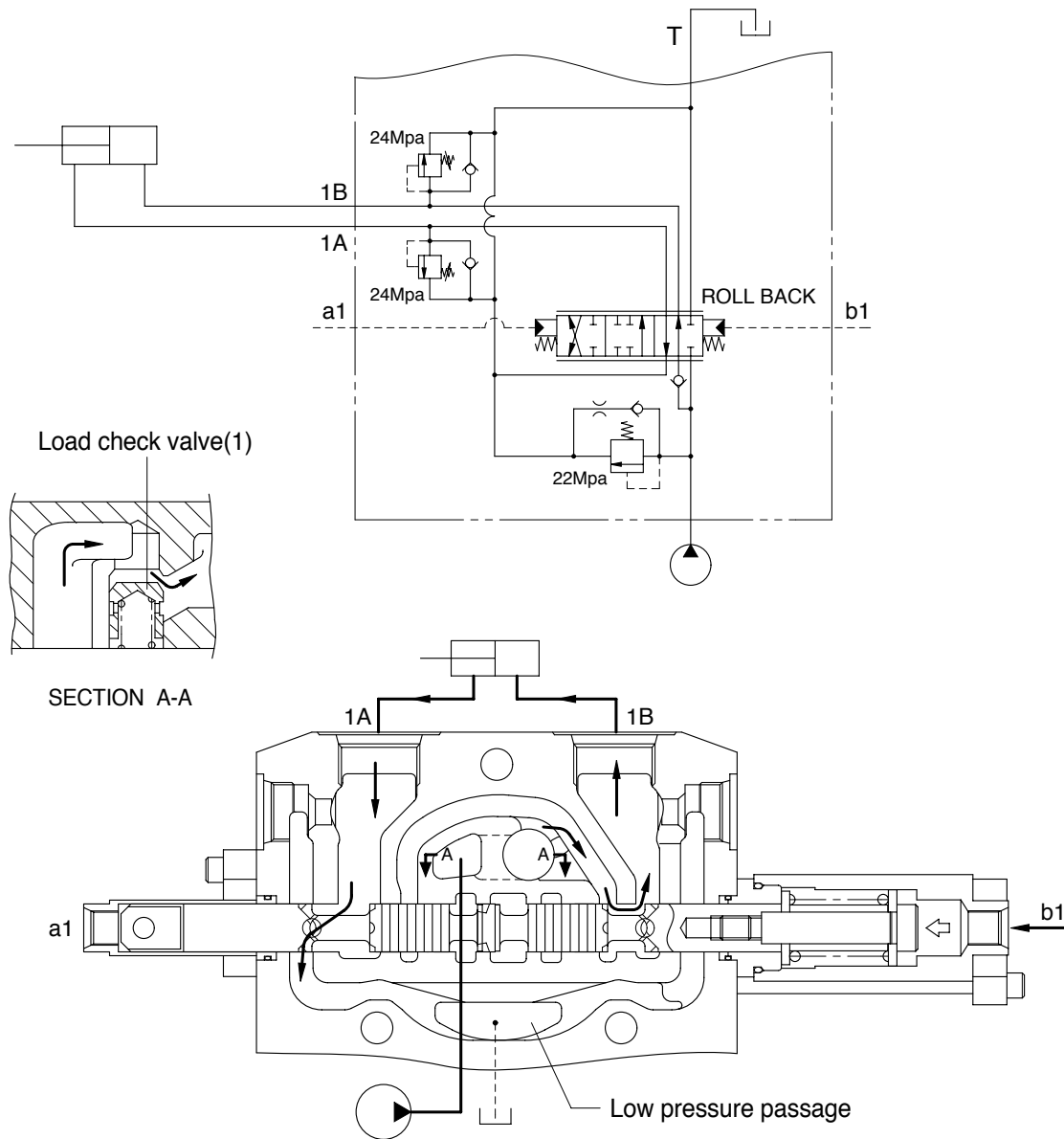

7406S6-23 26

When the pilot pressure from remote control valve is supplied to the pilot port(b1), the spool moves to the left and the neutral passage is closed.

The oil supplied from the pump pushes up the load check valve(1) and flow into bucket cylinder port(1B).

The pump pressure reaches proportionally the load of cylinder and fine control finished by shut off of the neutral passage.

The return oil from cylinder port(1A) flows into the tank via the low pressure passage.

(3) Dump position

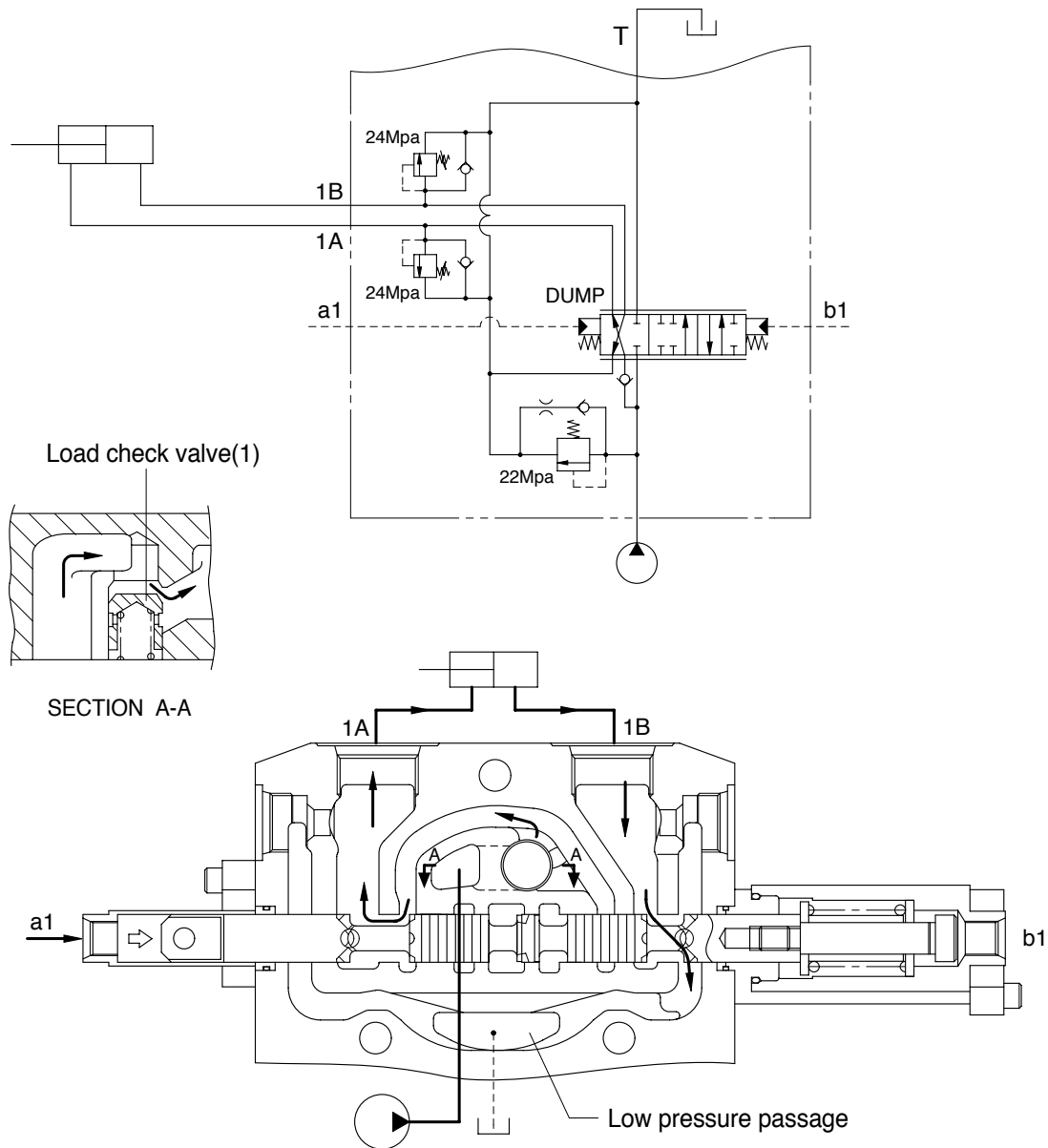

7406S 6-24

When the pilot pressure from remote control valve is supplied to the pilot port(a1), the spool moves to the right and the neutral passage is closed.

The oil supplied from the pump pushes up the load check valve(1) and flow into bucket cylinder port(1A).

The pump pressure reaches proportionally the load of cylinder and fine control finished by shut off of the neutral passage.

The return oil from cylinder port(1B) flows into the tank via the low pressure passage.

4) PRESSURE SETTING

A good pressure gage must be installed in the line which is in communication with the work port relief. A load must be applied in a manner to reach the set pressure of the relief unit.

(1) Main relief valve

Loosen lock nut.

Set adjusting nut to desired pressure setting.

If desired pressure setting cannot be achieved, add or remove shims as required.

Tighten lock nut.

Retest in similar manner as above.

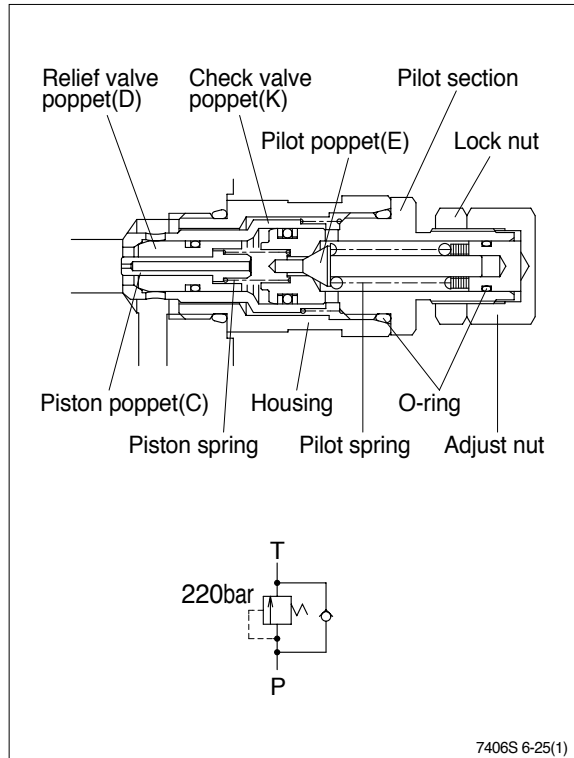

7406S 6-25(1)

(2) Port relief valve

Loosen lock nut.

Set adjusting screw to desired pressure setting.

Tighten lock nut.

Retest in similar manner as above.

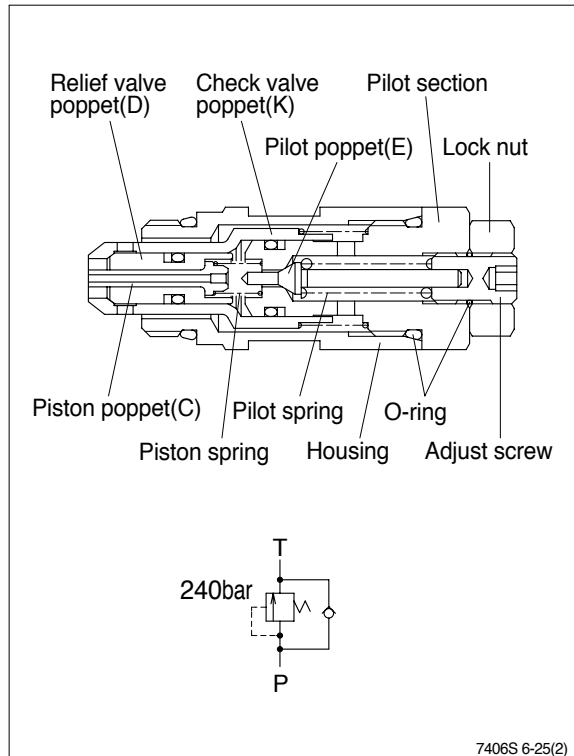

7406S 6-25(2)

5) MAIN RELIEF VALVE

(1) As relief

The relief valve is in communication between the high pressure port HP and low pressure LP. Oil is admitted through the hole in poppet C and because of the differential area between diameters A and B relief valve poppet D and check valve poppet K are tightly seated as shown in the first step.

The oil pressure in the high pressure port HP has reached the setting of the pilot poppet spring force and unseats the pilot poppet E and oil flows around the poppet through the cross drilled holes and to the low pressure area LP.

The loss of oil behind poppet C, effected by the opening of pilot poppet E, causes poppet C to move back and seat against pilot poppet E. This shuts off the oil flow to the area behind relief valve poppet D, and causes a low pressure area internally.

The imbalance of pressure on the inside as compared to that of the high pressure port HP, forces the relief valve poppet D to open and relieve the oil directly to the low pressure chamber LP in the valve.

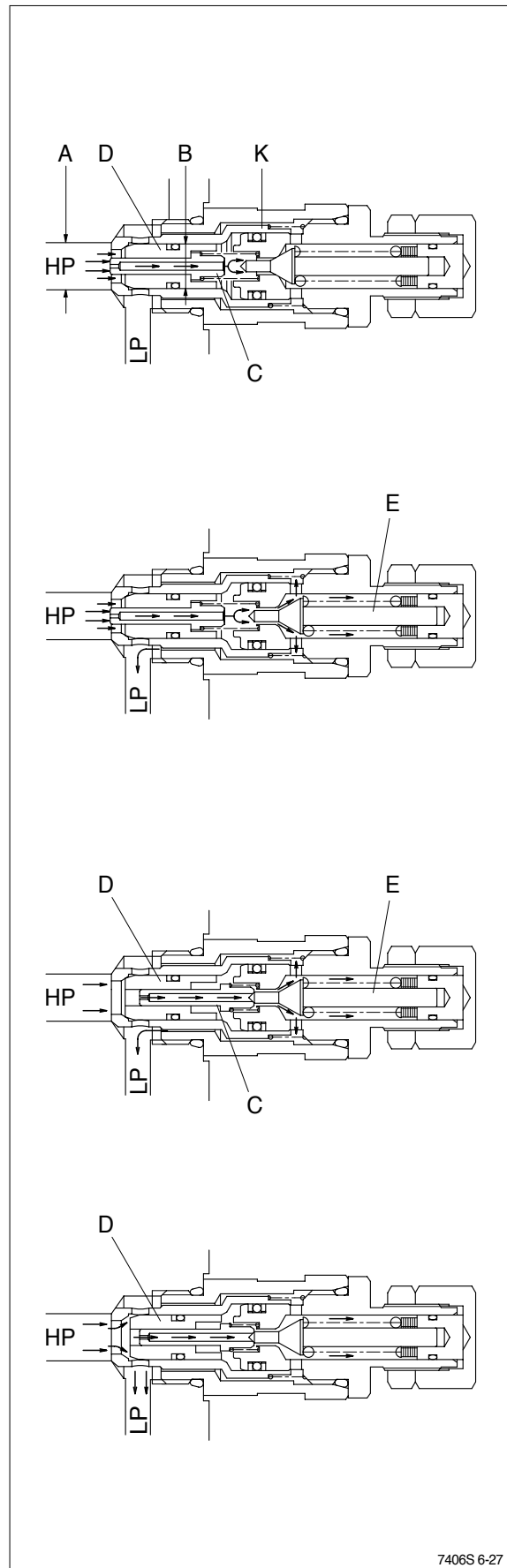

(2) As anti void

The anti-void unit supplies oil to the high pressure port HP when cavitation has occurred. A lower pressure exists in the port HP compared to the low pressure chamber LP. The difference between the effective area of diameter A and G causes imbalance of the check valve poppet K which unseats, thus allowing oil from the low pressure chamber LP to enter the port HP and fill the void.

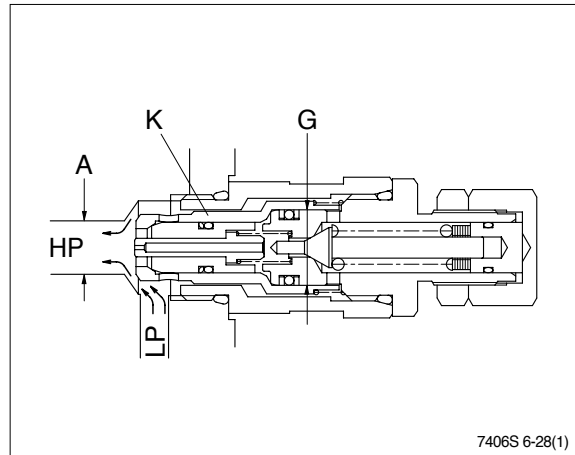

(3) As separate anti void

The anti-void check valve opens when cavitation occurs in the high pressure port HP and supplies oil from the reservoir LP to help fill this void. The poppet M is held on its seat by the port pressure HP, acting on the larger area behind the O-ring. When pressure HP drops below atmosphere, the tank pressure LP operating on the annular area A1-A2 will overcome the port pressure HP and the spring force to open the poppet. When the void is eliminated the spring will return the poppet which will then be tightly seated by the port pressure HP.

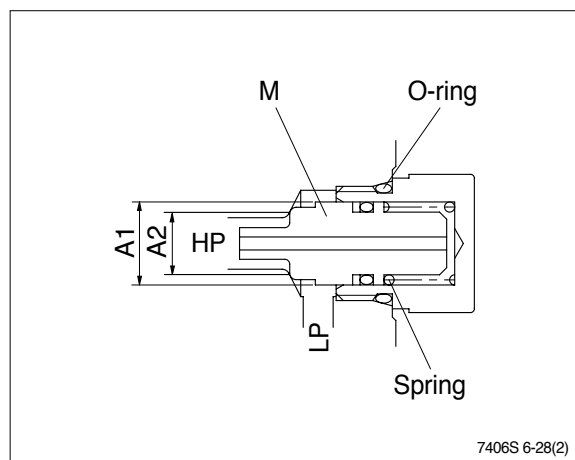

6) PORT RELIEF VALVE

(1) As relief

The relief valve is in communication between the high pressure port HP and low pressure LP. Oil is admitted through the hole in poppet C and because of the differential area between diameters A and B relief valve poppet D and check valve poppet K are tightly seated as shown in the first step.

The oil pressure in the high pressure port HP has reached the setting of the pilot poppet spring force and unseats the pilot poppet E and oil flows around the poppet through the cross drilled holes and to the low pressure area LP.

The loss of oil behind poppet C, effected by the opening of pilot poppet E, causes poppet C to move back and seat against pilot poppet E. This shuts off the oil flow to the area behind relief valve poppet D, and causes a low pressure area internally.

The imbalance of pressure on the inside as compared to that of the high pressure port HP, forces the relief valve poppet D to open and relieve the oil directly to the low pressure chamber LP in the valve.

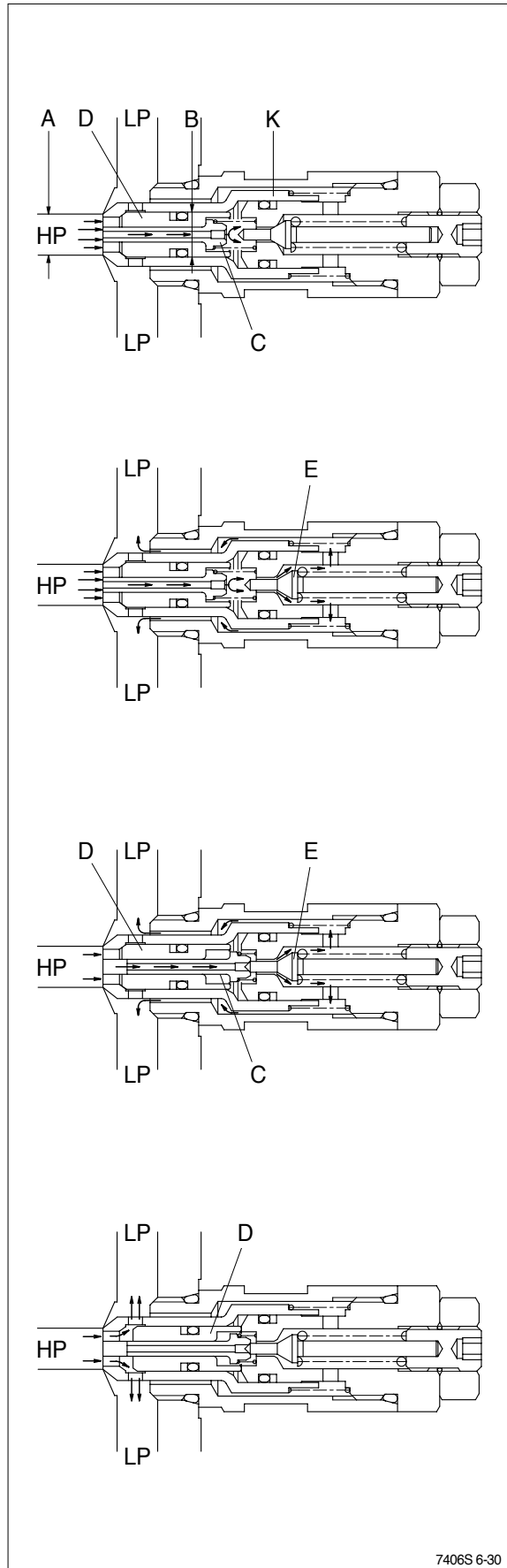

(2) As anti void

The anti-void unit supplies oil to the high pressure port HP when cavitation has occurred. A lower pressure exists in the port HP compared to the low pressure chamber LP. The difference between the effective area of diameter A and G causes imbalance of the check valve poppet K which unseats, thus allowing oil from the low pressure chamber LP to enter the port HP and fill the void.

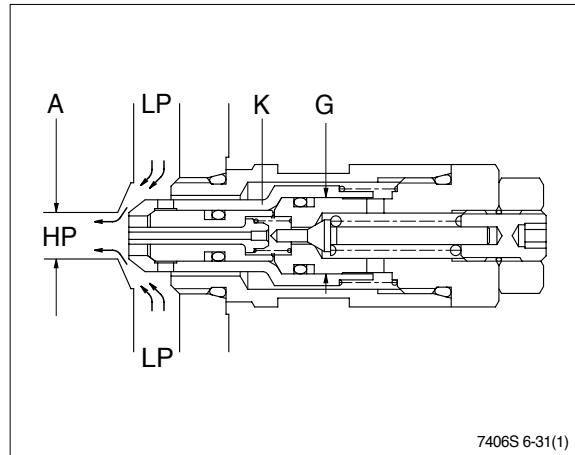

(3) As separate anti void

The anti-void check valve opens when cavitation occurs in the high pressure port HP and supplies oil from the reservoir LP to help fill this void. The poppet M is held on its seat by the port pressure HP, acting on the larger area behind the O-ring. When pressure HP drops below atmosphere, the tank pressure LP operating on the annular area A1-A2 will overcome the port pressure HP and the spring force to open the poppet. When the void is eliminated the spring will return the poppet which will then be tightly seated by the port pressure HP.

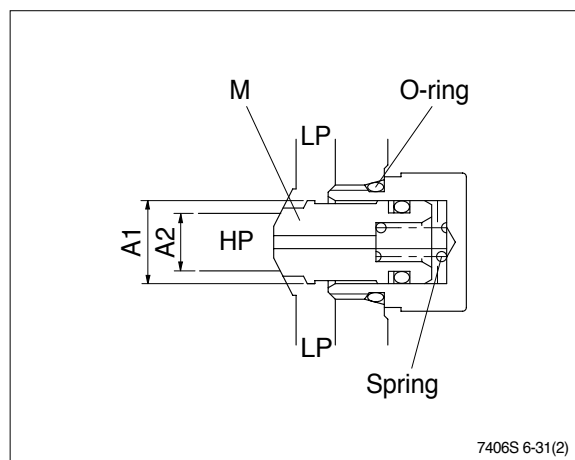

7. PILOT OIL SUPPLY UNIT

1) STRUCTURE

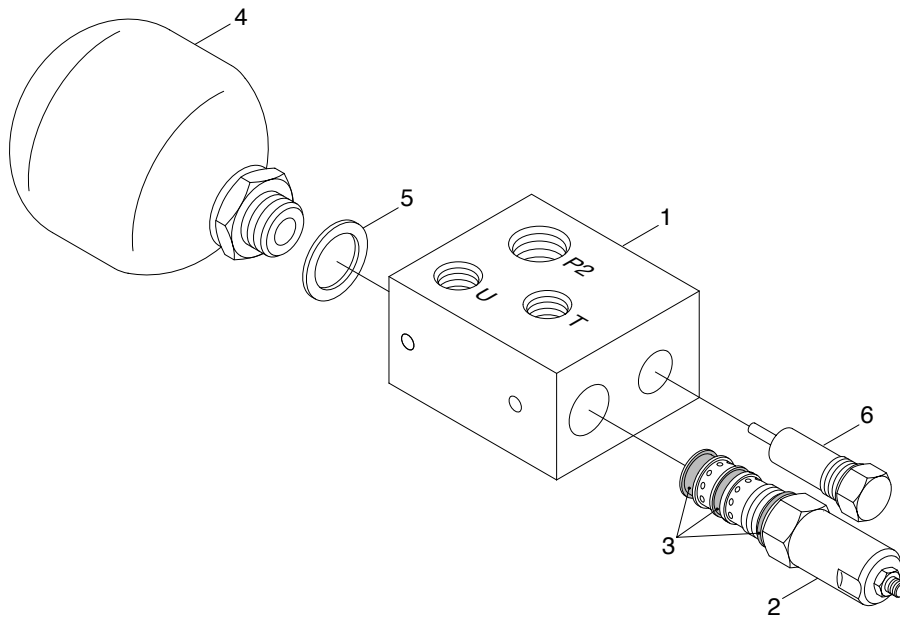

(740-3A) PILOT SUPPLY UNIT

- | | | | |
|---|-------------------|---|--------------|
| 1 | Manifold complete | 4 | Accumulator |
| 2 | Reducing valve | 5 | Gasket |
| 3 | Seal kit | 6 | Relife valve |

2) OPERATION

The pilot supply manifold reduces the pressure from the high pressure circuit to a low pressure circuit in order to supply the remote control valve.

The accumulator satisfies short term peak power demands and is a source of emergency power in case of main circuit pressure failures.

The unit consists of the housing, the accumulator(4), the relief valve(6), the check valve and the reducing valve(2).

The flow path is from the high pressure circuit through port P2 to the pressure reducing valve(2). The pressure is reduced in the reducing valve(2) and oil passes the check valve into the accumulator(4) and to the port U, which is connected with the remote control valve.

The pressure relief valve(6) protects the pilot circuit in case of the reducing valve(2) failures or external increase of pressure.

8. BOOM AND BUCKET CYLINDER

The boom cylinders are two unit and the bucket cylinder is one unit. They use a bolt on rod guide.

The piston(12) threads on to the rod(2) and is retained by a nylon nut(18).

The piston seals against the tube(1) with piston seal(15). Two wear rings(16) are located on each side of the piston seal.

The gland(3, the rod guide) seals against the tube with an O-ring(10). The cylinder thread seals against the rod with a lip type buffer ring(7) and a rod seal(5). A dust wiper(8) cleans the rod when it is retracted.

1) BOOM CYLINDER

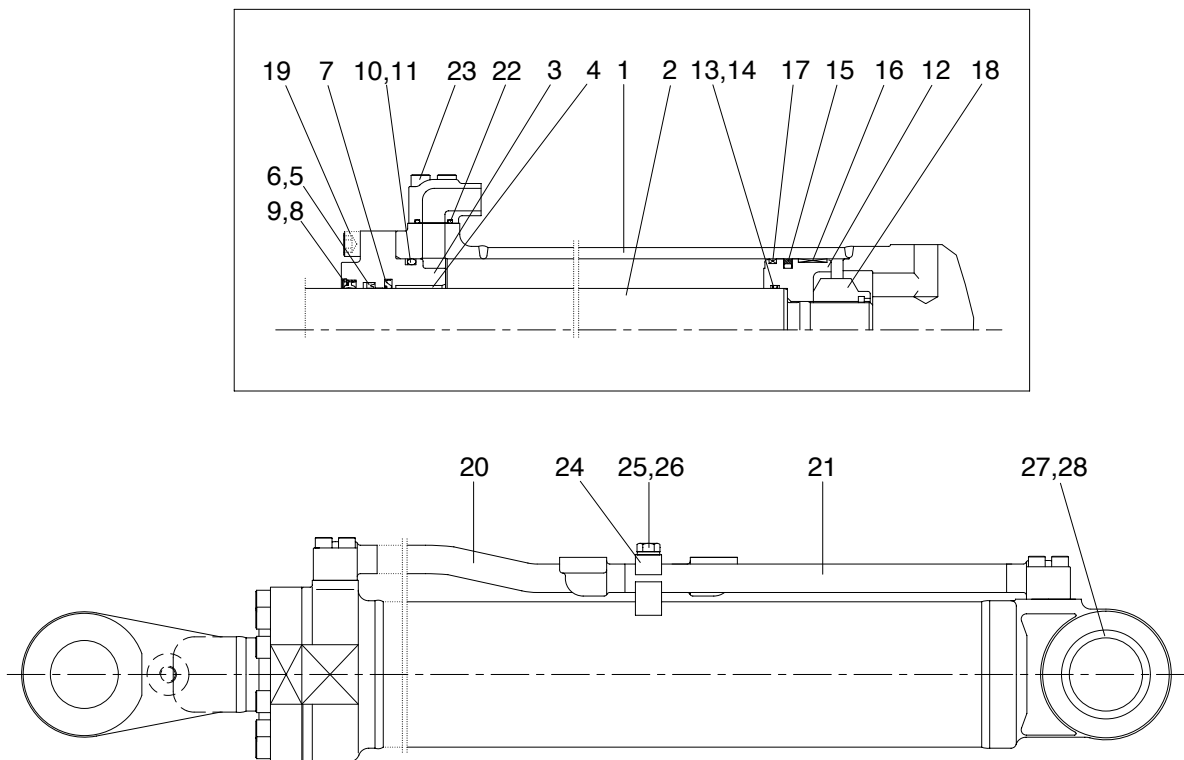

7407WE10

1	Tube assy	11	Back up ring	21	Pipe assy
2	Rod assy	12	Piston	22	O-ring
3	Gland	13	O-ring	23	Socket bolt
4	Bushing	14	Back up ring	24	Pipe clamp
5	Rod seal	15	Piston seal	25	Hexagon bolt
6	Back up ring	16	Wear ring	26	Spring washer
7	Buffer ring	17	Dust ring	27	Bushing
8	Dust wiper	18	Nylon nut	28	Dust seal
9	Snap ring	19	Socket bolt		
10	O-ring	20	Pipe assy		

2) BUCKET CYLINDER

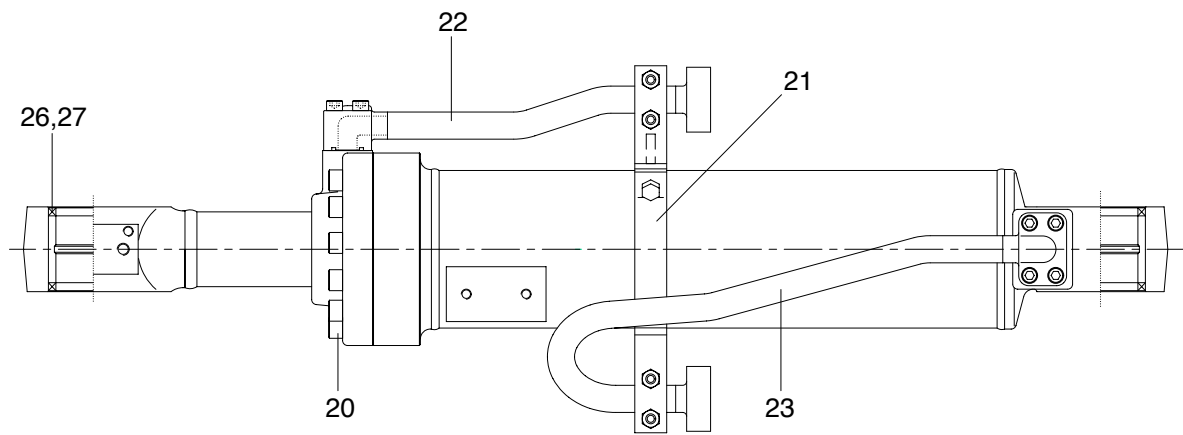
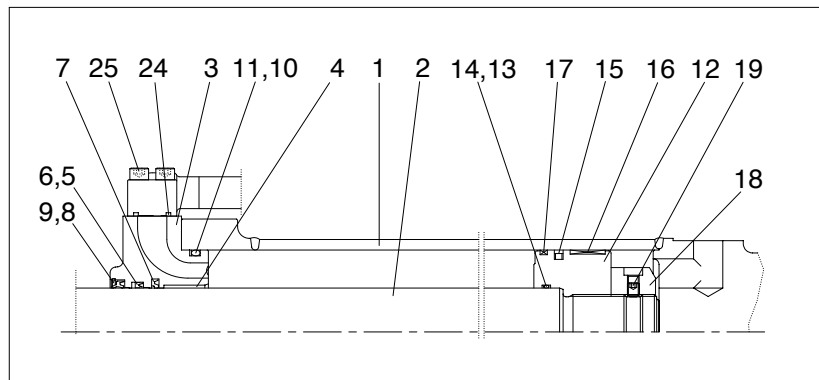

7407WE11

- | | | | | | |
|---|--------------|----|--------------|----|-------------|
| 1 | Tube assy | 10 | O-ring | 19 | Set screw |
| 2 | Rod assy | 11 | Back up ring | 20 | Socket bolt |
| 3 | Gland | 12 | Piston | 21 | Band assy |
| 4 | Bushing | 13 | O-ring | 22 | Pipe assy |
| 5 | Rod seal | 14 | Back up ring | 23 | Pipe assy |
| 6 | Back up ring | 15 | Piston seal | 24 | O-ring |
| 7 | Buffer ring | 16 | Wear ring | 25 | Socket bolt |
| 8 | Dust wiper | 17 | Dust ring | 26 | Bushing |
| 9 | Snap ring | 18 | Nylon nut | 27 | Dust seal |

9. HYDRAULIC OIL TANK

1) STRUCTURE

- The oil from the hydraulic tank is sent from the pump through main control valve to the cylinders. In the return circuit, the oil from various parts merges.
- A part of oil is cooled in the oil cooler(If equipped), passes through the hydraulic filter and returns to the hydraulic tank(1).
- If the hydraulic return oil filter becomes clogged, return filter bypass valve(6) acts to allow the oil to return directly to the hydraulic tank(1). This prevents damage to the hydraulic filter(5). The bypass valve(6) is also actuated when negative pressure is generated in the circuit.

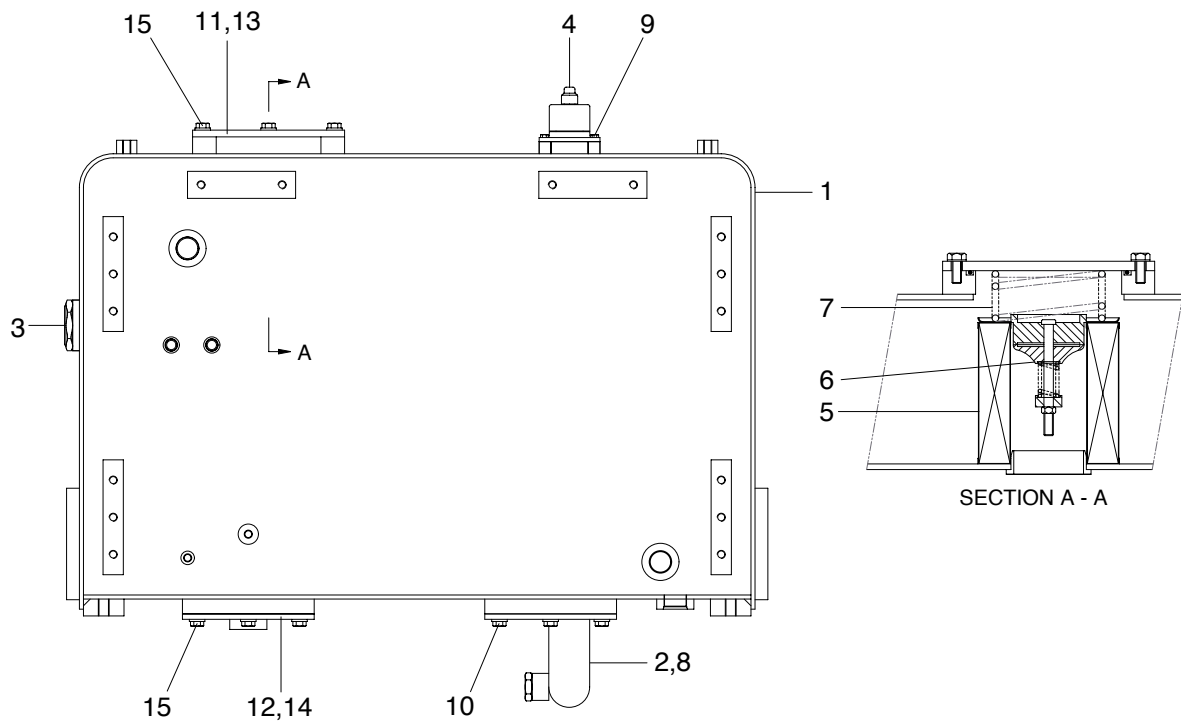

7407WE13

1	Hydraulic tank	6	By pass valve	11	Cover
2	Pipe assy	7	Spring	12	Cover
3	Sight gauge	8	O-ring	13	O-ring
4	Air breather	9	Socket bolt	14	O-ring
5	Element assy	10	Bolt	15	Bolt

2) RETURN OIL FILTER BYPASS VALVE

(1) When the filter is clogged

Bypass valve(1) is opened and the oil returns directly to the tank without passing through the filter.

Bypass valve set pressure : 1.36kg/cm²
(19.3psi)

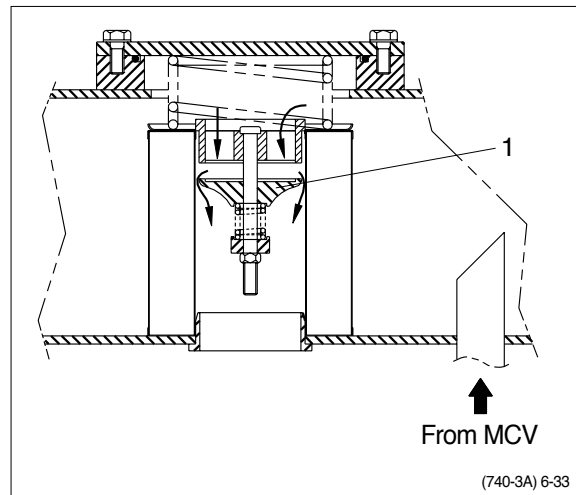

3) AIR BREATHER

The air breather is equipped with the capacity to perform three functions simultaneously-as an air filter, breathing valve, and as a lubrication opening.

(1) Preventing negative pressure inside the tank

The tank is a pressurized sealed type, so negative pressure is formed inside the hydraulic tank when the oil level drops during operations. When this happens, the difference in pressure between the tank and the outside atmospheric pressure opens the poppet in the breather, and air from the outside is let into the tank or prevent negative pressure.

(2) Preventing excessive pressure inside the tank

When the hydraulic cylinder is being used, the oil level in the hydraulic system increases and as temperature rises. If the hydraulic pressure rises above the set pressure, breather is actuated to release the hydraulic pressure inside the tank.

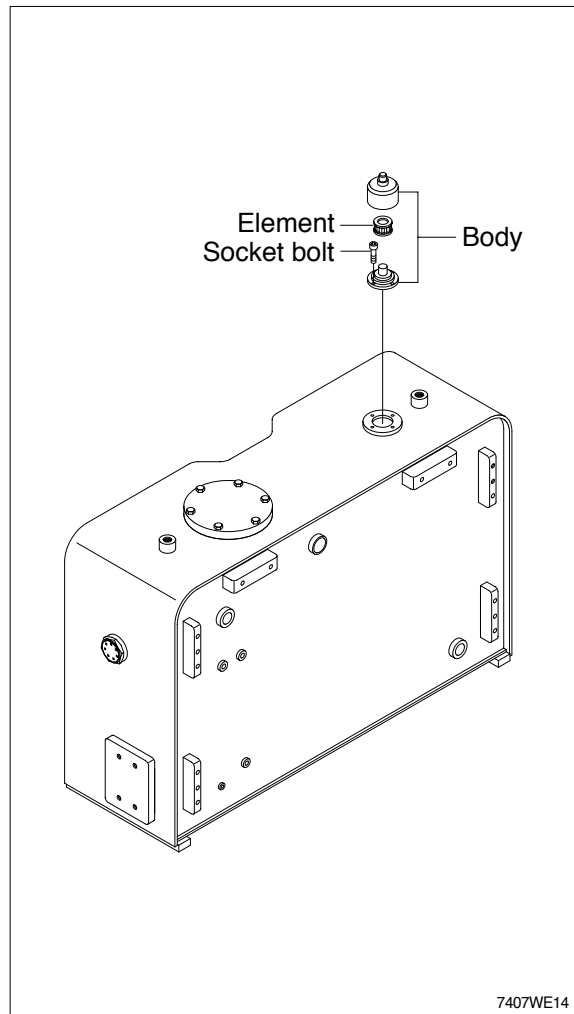

10. ACCUMULATOR

The accumulator is installed at the pilot oil supply unit. When the boom is left the raised position, and the control levers are operated with the engine stopped the pressure of the compressed nitrogen gas inside the accumulator sends pilot pressure to the control valve to actuate it and allow the boom and bucket to come down under their own weight.

Type of gas	Nitrogen gas(N ₂)
Volume of gas	0.75 (0.2 U.S.gal)
Charging pressure of gas	16kg/cm ² (228psi)
Max actuating pressure	30kg/cm ² (427psi)

