

GROUP 2 ELECTRICAL CIRCUIT

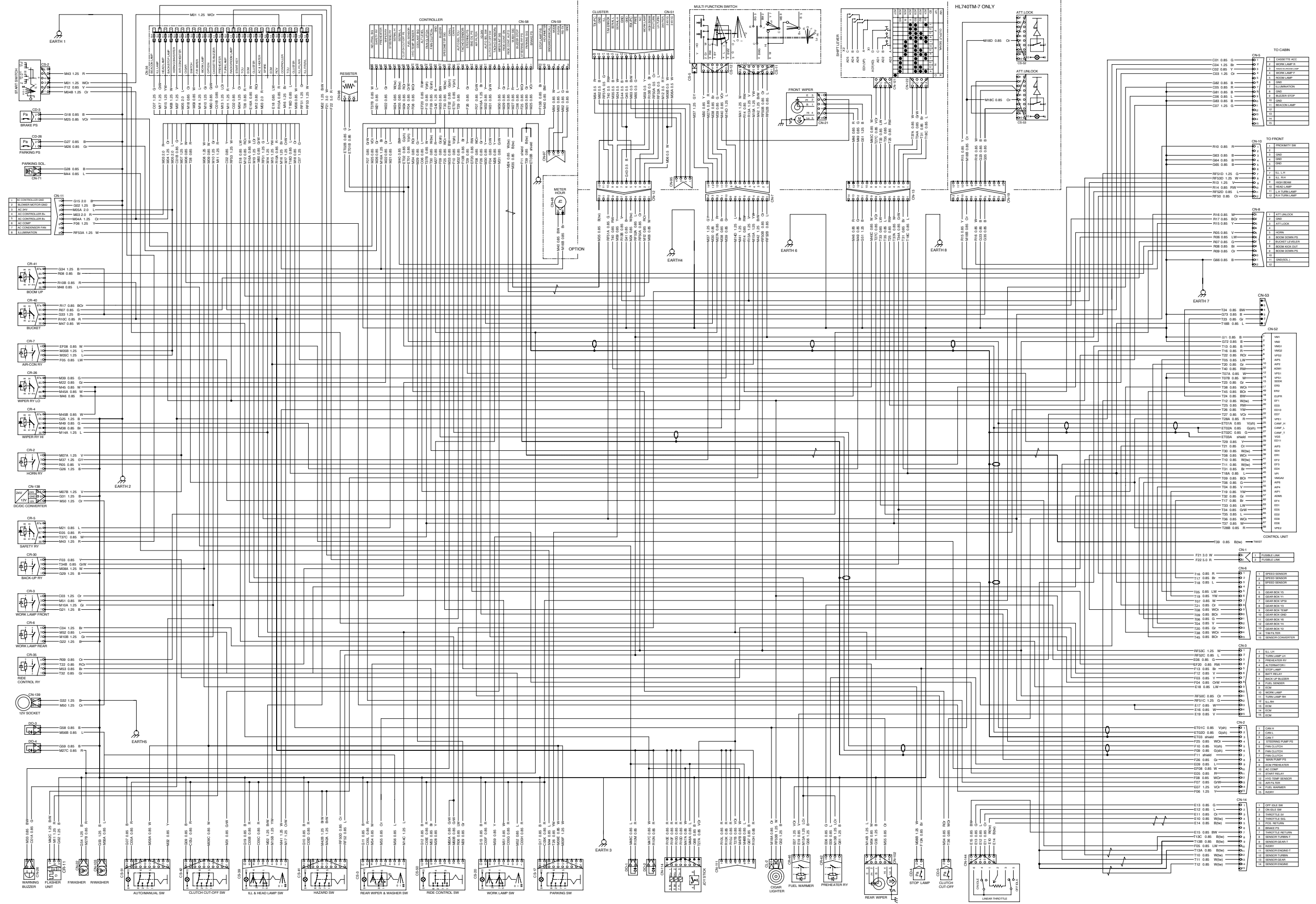

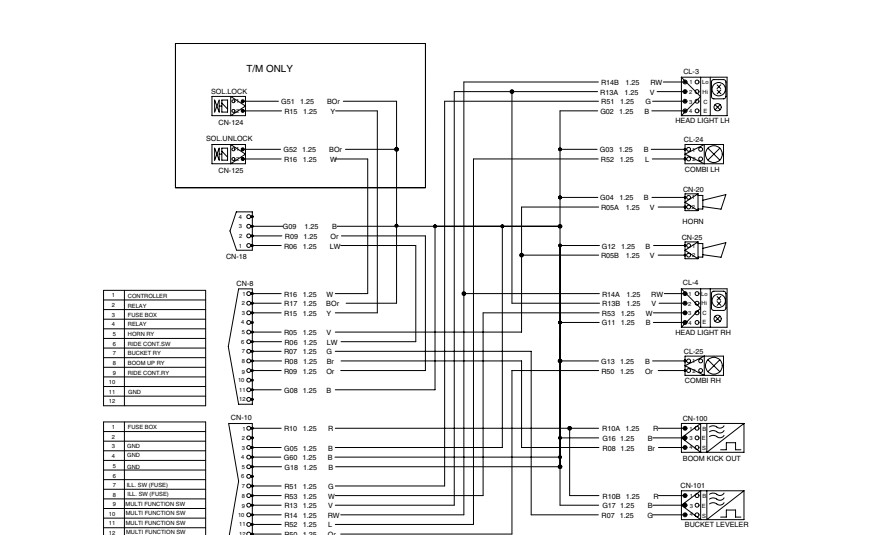

FRONT SIDE

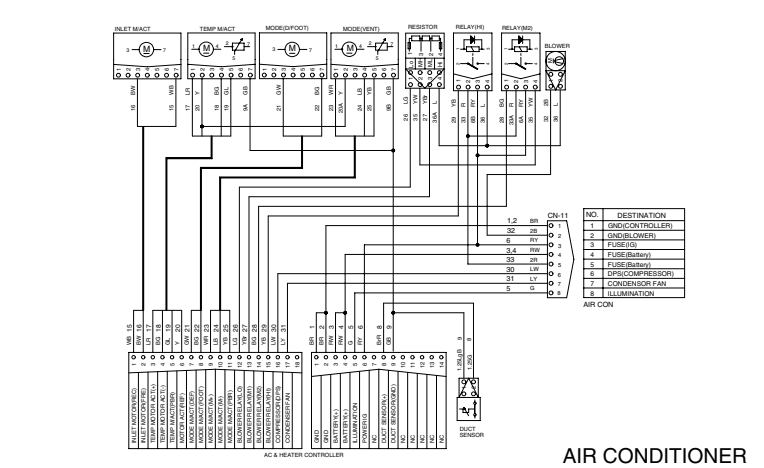

AIR CONDITIONER

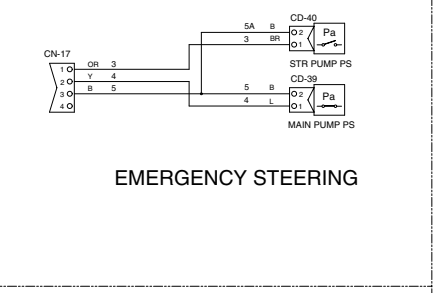

EMERGENCY STEERING

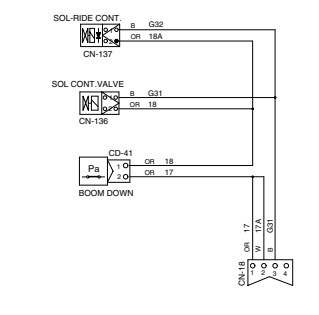

RIDE CONTROL

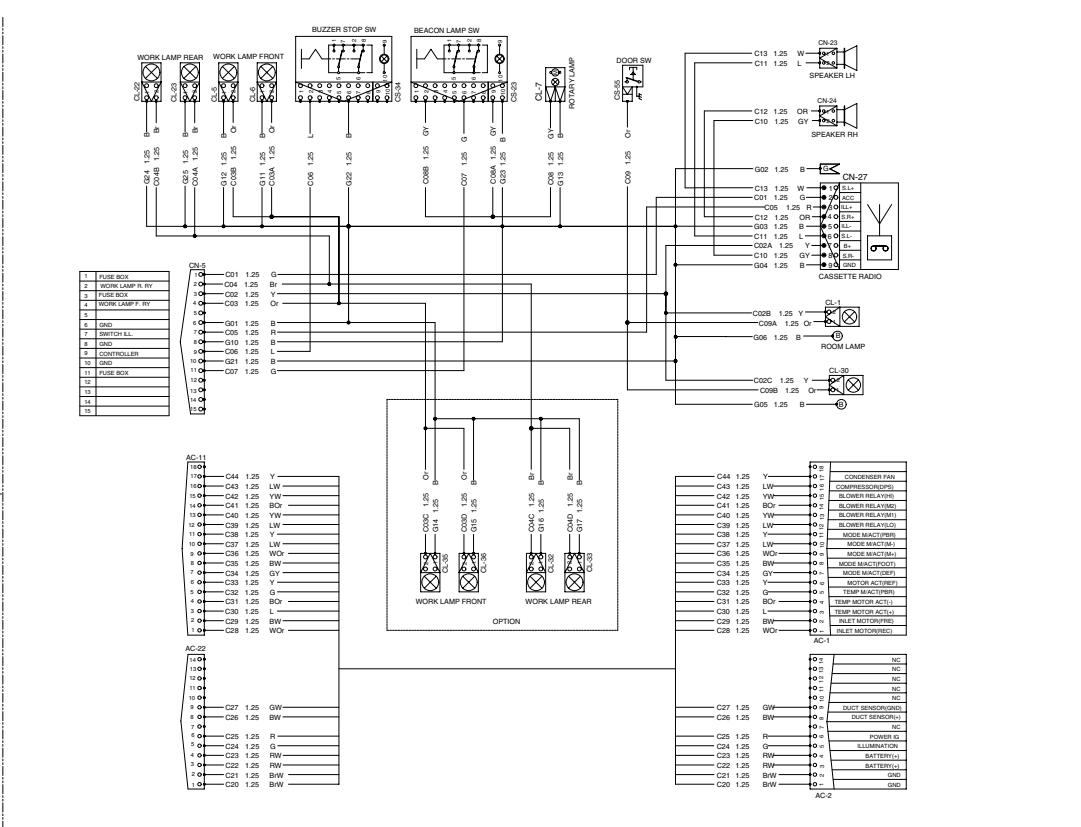

CAB SIDE

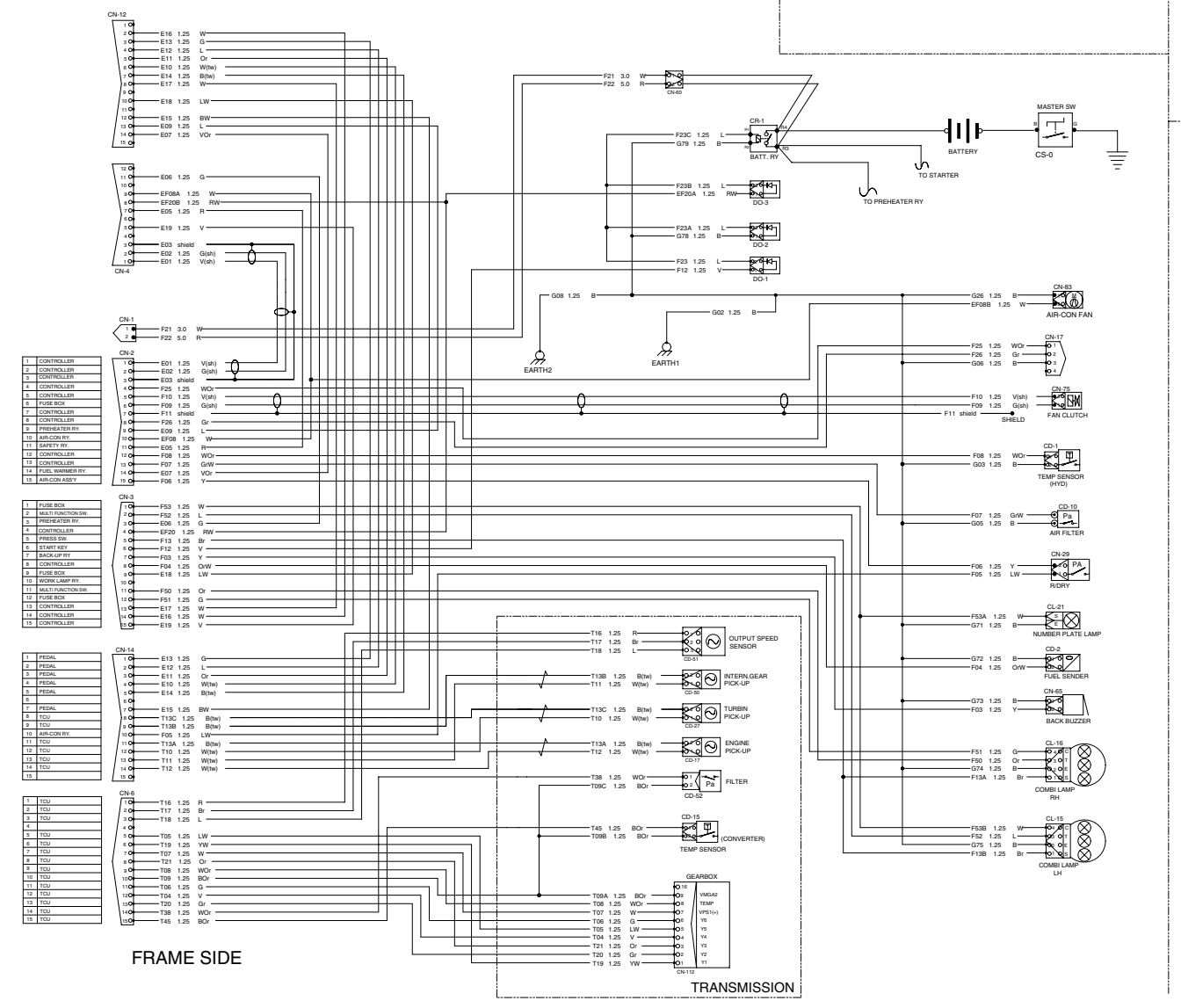

FRAME SIDE

TRANSMISSION

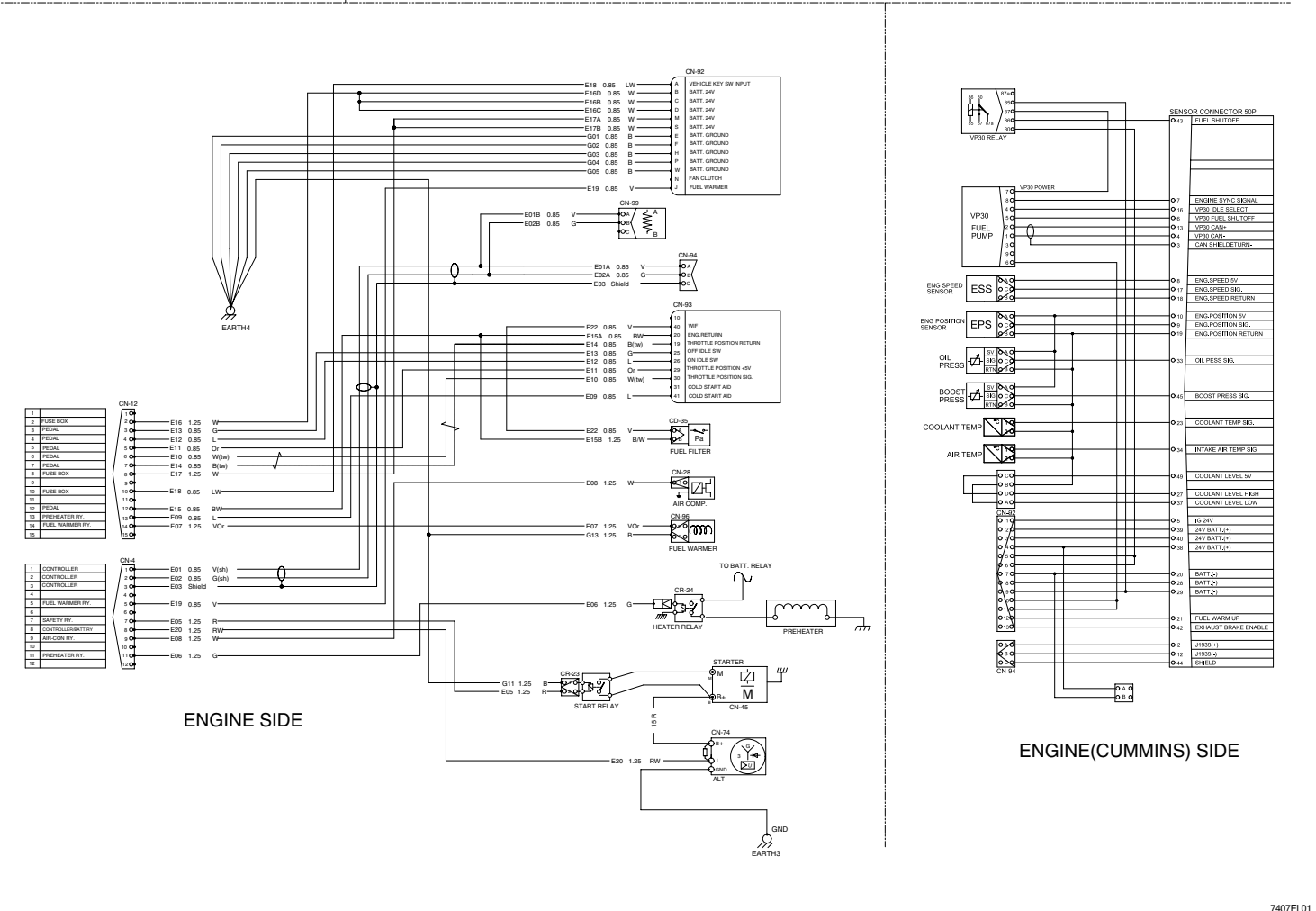

ENGINE SIDE

ENGINE(CUMMINS) SIDE

# 1. ILLUMINATION CIRCUIT

## 1) OPERATING FLOW

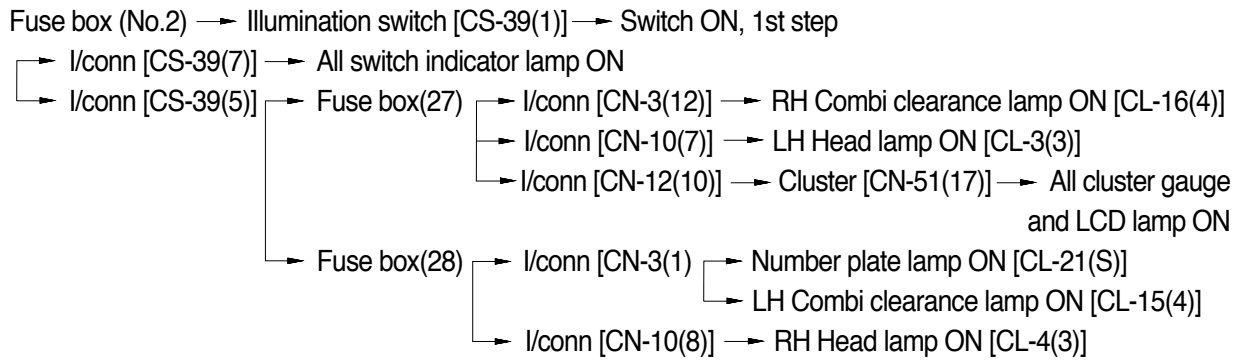

## 2) CHECK POINT

Engine	Key switch	Check point	Voltage
OFF	ON	- GND (Switch input) - GND (Switch output) - GND (To light) - GND (To cluster)	20~25V

GND : Ground

# ILLUMINATION CIRCUIT

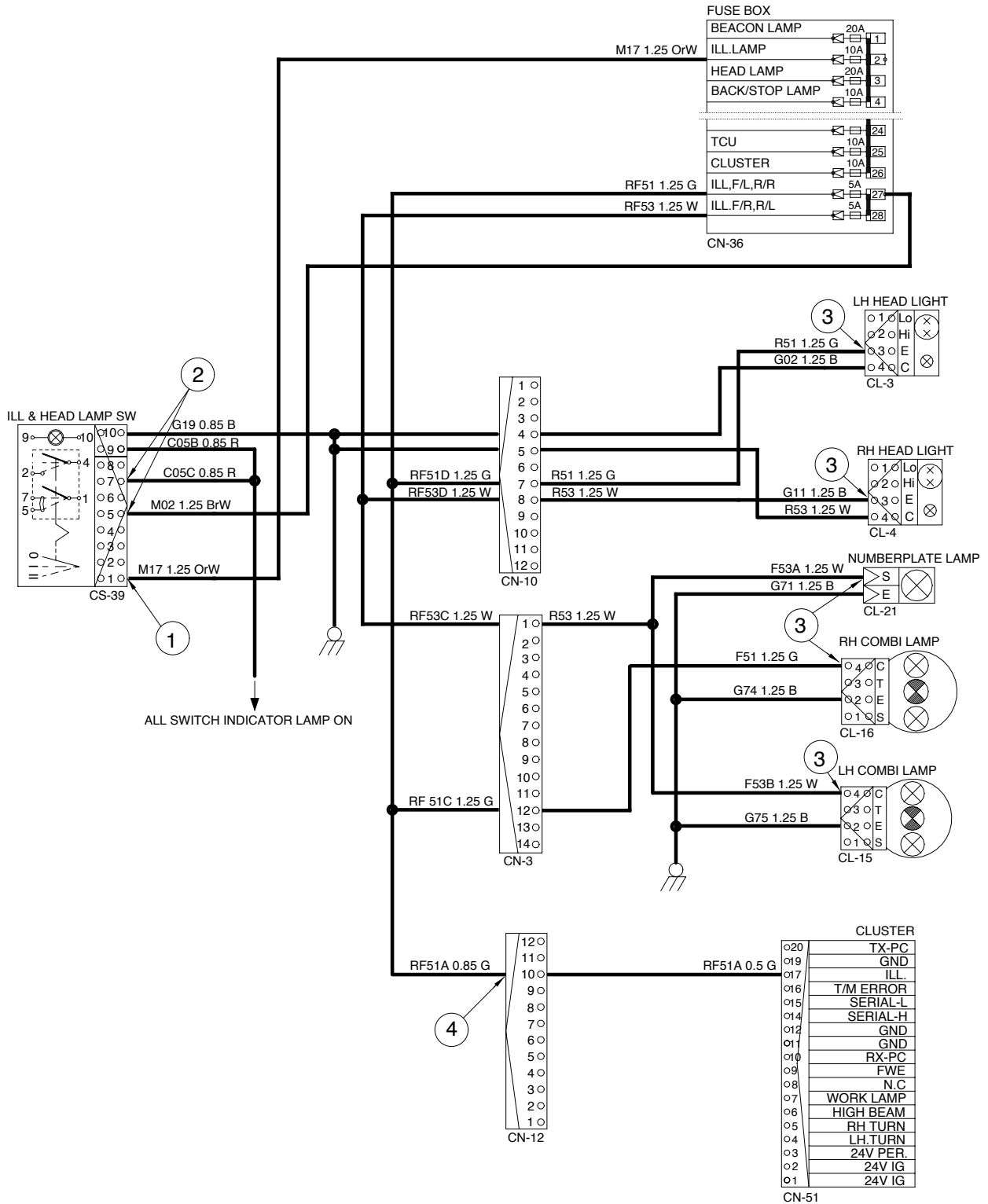

## 2. HEAD LIGHT CIRCUIT

### 1) OPERATING FLOW

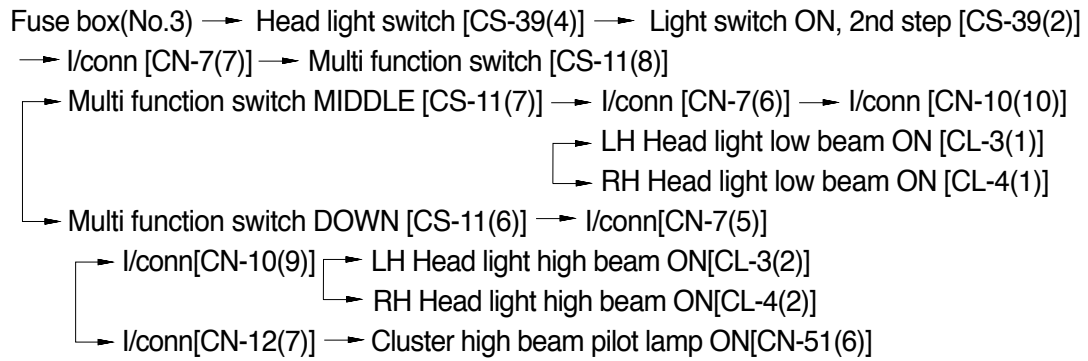

### 2) CHECK POINT

Engine	Key switch	Check point	Voltage
OFF	ON	- GND (Switch input) - GND (Switch output) - GND (Multi function input) - GND (Multi function output) - GND (Multi function output) - GND (Low beam) - GND (High beam) - GND (Passing B+)	20~25V

GND : Ground

# HEAD LIGHT CIRCUIT

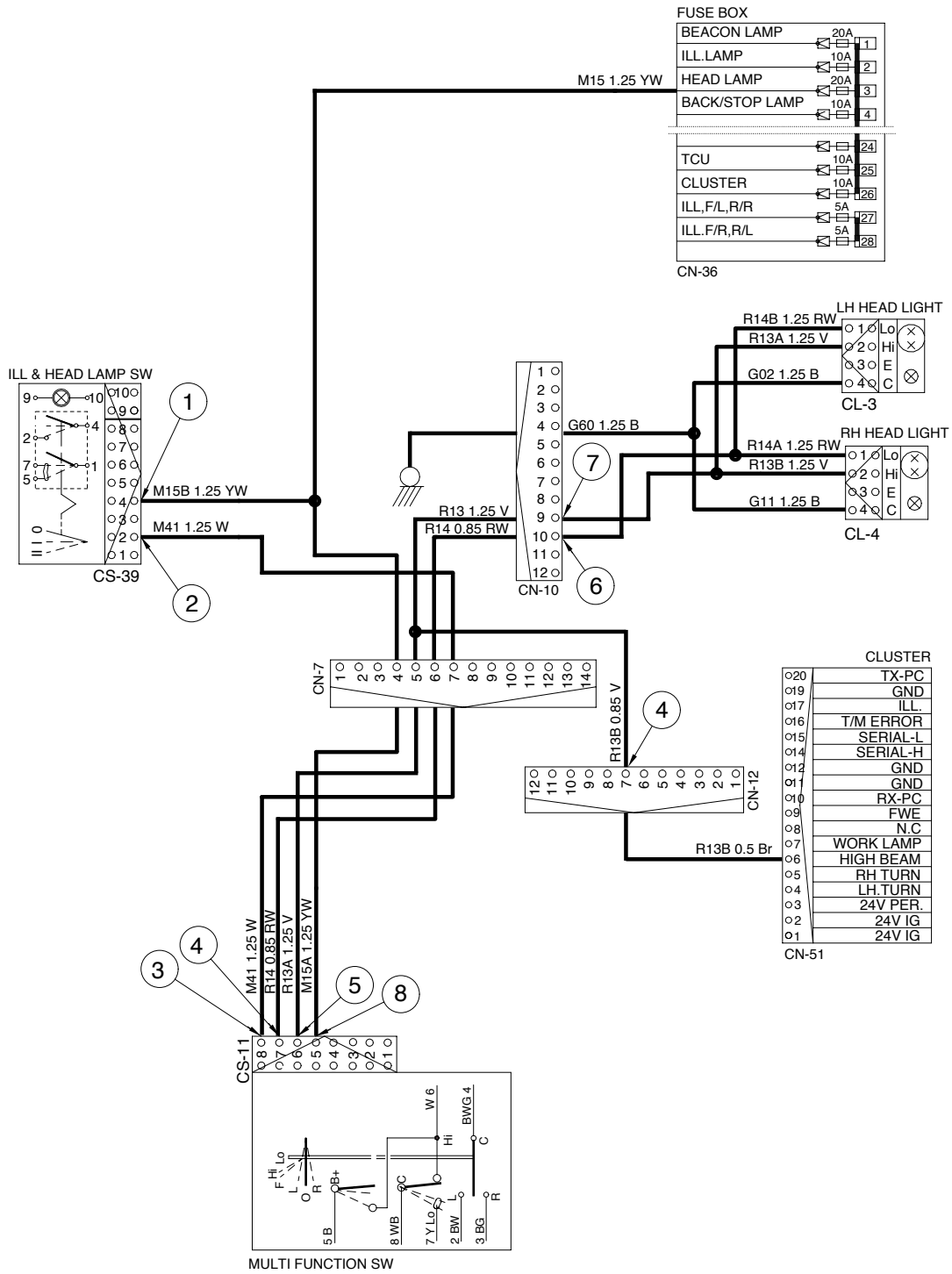

7407EL04

### 3. WORK LIGHT CIRCUIT

#### 1) OPERATING FLOW

Illumination switch : ON position

##### (1) Work lamp switch ON (1st step)

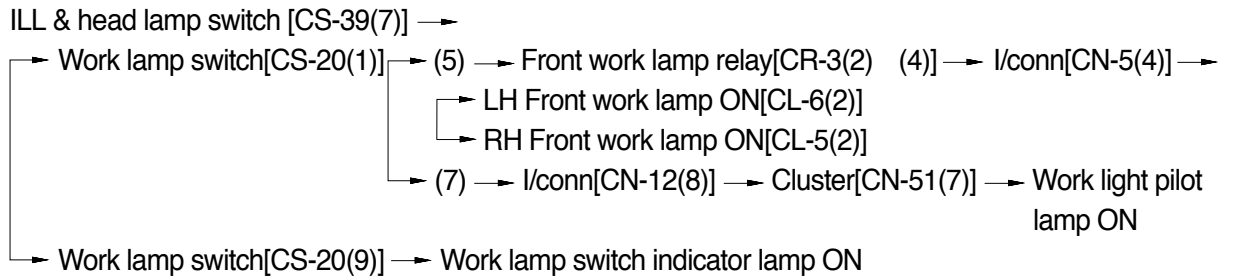

##### (2) Work lamp switch (2nd step)

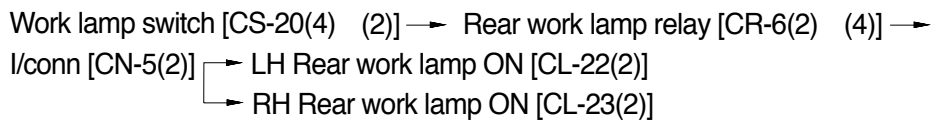

#### 2) CHECK POINT

Engine	Key switch	Check point	Voltage
OFF	ON	<ul style="list-style-type: none"> <li>- GND (Work lamp power input)</li> <li>- GND (Work lamp power output)</li> <li>- GND (Front work lamp)</li> <li>- GND (Rear work lamp)</li> </ul>	20~25V

GND : Ground

# WORK LIGHT CIRCUIT

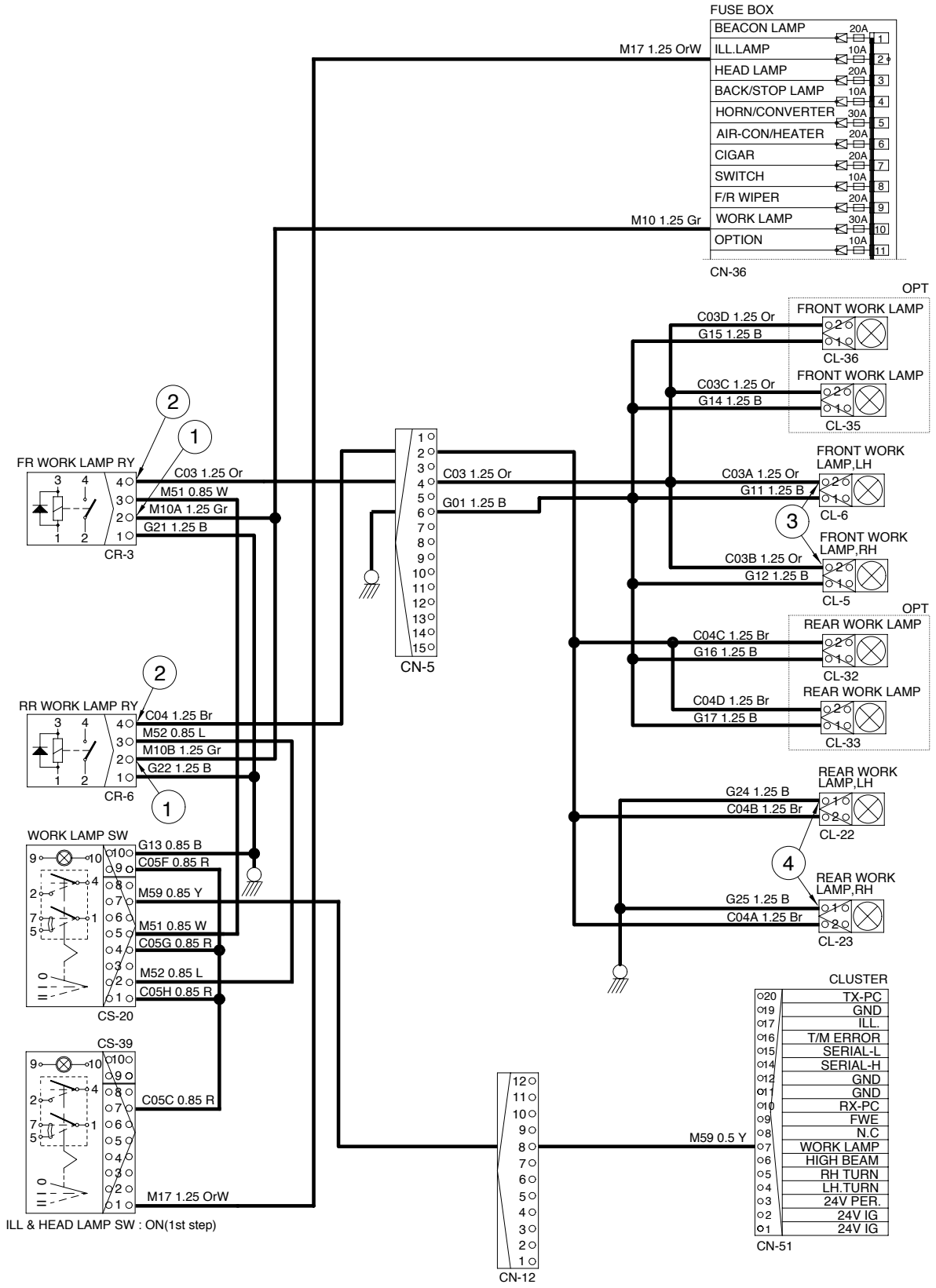

7407EL05



#### 4. CHARGING CIRCUIT

When the starter is activated and the engine is started, the operator releases the key switch to the ON position.

Charging current generated by operating alternator flows into the battery through the battery relay (CR-1).

The current also flows from alternator to each electrical component and controller through the fuse box.

##### 1) OPERATING FLOW

###### (1) Warning flow

Alternator [CN-74(1)] → I/conn [CN-4(8)] → I/conn [CN-3(4)] → Controller [CN-58(25)]  
 → Cluster charge warning lamp ON

###### (2) Charging flow

Alternator → Starter [CN-45(B<sup>+</sup>)] → Battery relay [CR-1]  
 ↳ Battery(+) terminal → Charging  
 ↳ I/conn [CN-60(1),(2)] → I/conn [CN-1(1),(2)] → Fuse box

##### 2) CHECK POINT

Engine	Key switch	Check point	Voltage
Running	ON	- GND (Battery) - GND (Battery relay) - GND (ALT B <sup>+</sup> ) - GND (ALT I) - GND (Controller) - GND (Fuse box)	20~28V

GND : Ground

# CHARGING CIRCUIT

CONTROLLER

036	NEUTRAL SIG
035	SAFETY RY
034	PREHEATER
033	WIPER RY
032	STEERING RY
031	SERIAL-H
030	SERIAL-L
029	CLUTCH CUT-OFF PS
028	FUEL SENSOR
027	HYD TEMP SENDER
026	COOLANT SIG
025	ALT LEVEL
024	REMOTE FAN(-)
023	REMOTE FAN(+)
022	GND
021	BUZZER
020	SPEEDMETER SIG.
019	CAN-L
018	CAN-H
017	AUTO SEL.TCU
016	TAHCO SENSOR -
015	STEERING PS
014	ENG OIL PS
013	AIR FILTER
012	IG 24V
011	AUTO SEL.SW
010	CLUTCH CUT-OFF SW
009	TACHO SENSOR+
008	WIPER INT SIG
007	RIDE CONT. ON
006	RIDE CONT. AUTO
005	WASH SIG
004	BUZZER STOP
003	STEERING PIP PS
002	PARKING SIG
001	BRAKE PS

CN-58

EF20 0.85 RW

5

FUSE BOX

1	BEACON LAMP	20A
2	ILL. LAMP	10A
3	HEAD LAMP	20A
4	BACK/STOP LAMP	10A
5	HORN/CONVERTER	30A
6	AIR-CON/HEATER	20A
7	CIGAR	20A
8	SWITCH	10A
9	F/R WIPER	20A
10	WORK LAMP	30A
11	OPTION	10A
12	CASSETTE/BUZZER	5A
13	PREHEATER	30A
14	TURN LAMP	20A
15	RADIO/ROOM LAMP	5A
16	START KEY	30A
17	TCU	10A
18	ECM	10A
19	CLUSTER	10A
20	AC & HEATER	10A
21	SPARE	10A
22	ECM	5A
23	RCV	10A
24	CONTROLLER	10A
25	TCU	10A
26	CLUSTER	10A
27	ILL. F/L,R/R	5A
28	ILL. F/R,R/L	5A

CN-36

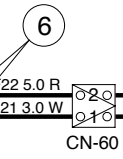

1

2

3

4

EF20 0.85 RW

EF20 1.25 RW

E20 1.25 RW

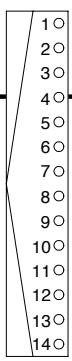

CN-3

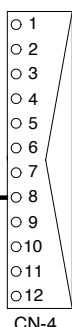

CN-4

## 5. STARTING CIRCUIT

### 1) OPERATING FLOW

Battery(+) terminal → Battery relay(R4 terminal) → Fusible link [CN-60(1)]  
 → I/conn [CN-1(1)] → Fuse box (No.15) → Start switch [CS-2(1)]

The gear selector lever is neutral position. It is necessary condition before the starting.

The gear selector has an output signal which is activated whenever the shift lever is in the neutral position. This signal can be used to control a relay and prevent engine from starting whenever the shift lever is not in the neutral position.

#### (1) When start key switch is in ON position

Start switch ON → Start switch [CS-2(2)] → I/conn [CN-3(6)] → Battery relay [CR-1]  
 → Battery relay operating(All power is supplied with the electric component)  
 → Start switch [CS-2(3)] → Fuse box [No.23] → Fuse box (No.22) →  
 I/conn [CN-3(9)] → I/conn [CN-12(10)] → ECM[CN-92(A)]

#### (2) When start key switch is in START position

Start switch START [CS-2(5)] → Start safety relay [CR-5(30)] → Start safety relay [CR-5(87)]  
 → I/conn [CN-2(11)] → [CN-4(7)] → Start relay [CR-23(2)] →  
 Starter(Terminal B<sup>+</sup> and M connector of start motor)

### 2) CHECK POINT

Engine	Key switch	Check point	Voltage
Running	ON	- GND (Battery B <sup>+</sup> ) - GND (Fusible link) - GND (Start key B terminal) - GND (Start key BR terminal) - GND (I/conn CN-3(6)) - GND (Start key ST terminal) - GND (Start safety relay output) - GND (Controller) - GND (Start key ACC terminal)	20~25V

GND : Ground

ECM : Electronic control module

# STARTING CIRCUIT

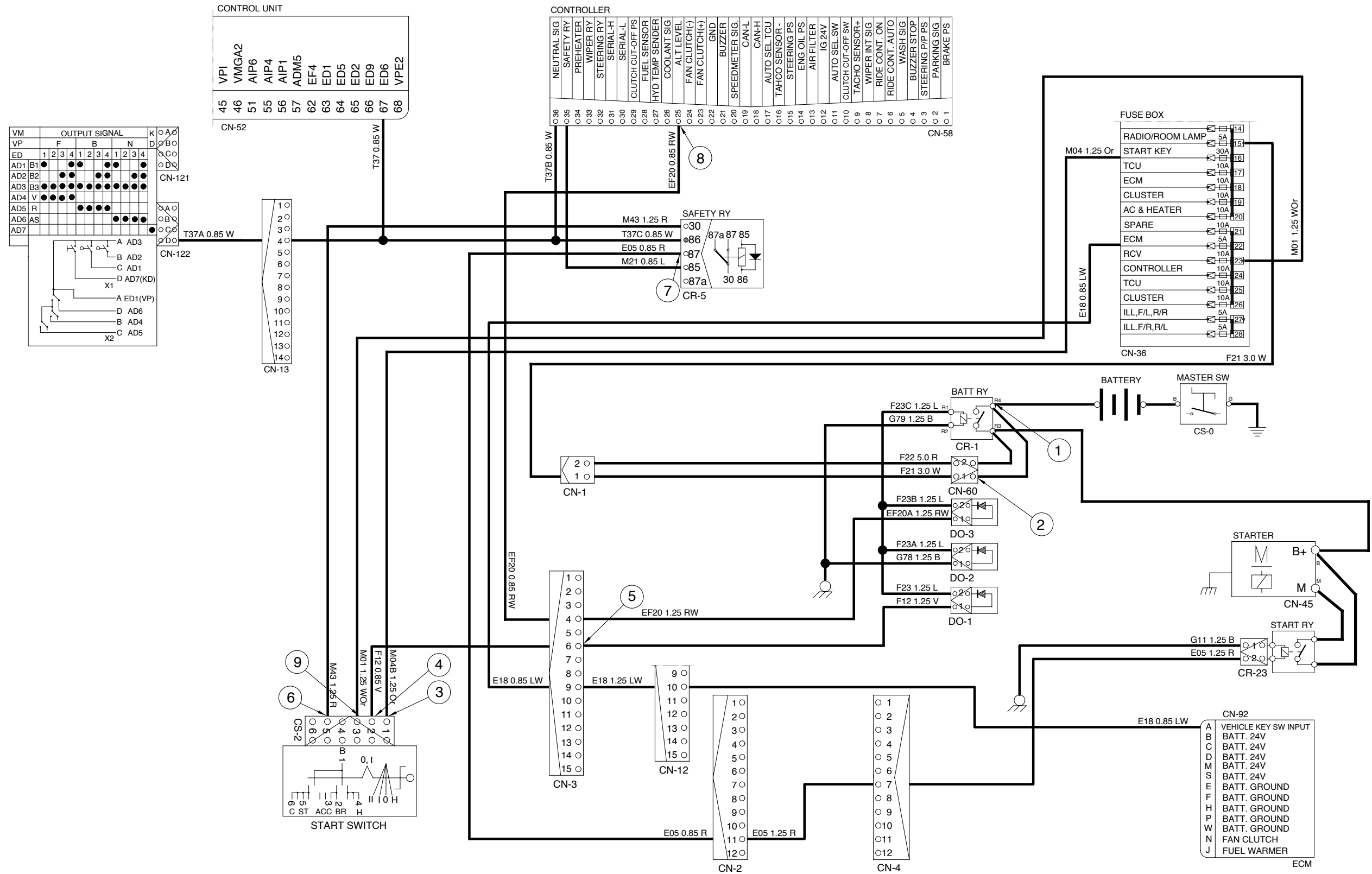

## 6. ELECTRIC PARKING, DECLUTCH CIRCUIT

### 1) OPERATING FLOW

#### (1) Parking OFF

Fuse box (No.8) → Parking switch OFF [CS-17(6)‡ (8)] → Parking solenoid ON (Activated)  
 → Parking brake released (By hydraulic pressure)

#### (2) Parking ON

Fuse box (No.8) → Parking switch ON

- Parking solenoid [CN-71] OFF
  - Parking brake applied [By spring force]
- [CS-17(5)‡ (7)] → T/M control unit [CN-52(21)]
  - T/M declutch

#### (3) Declutch ON

Fuse box (No.8) → Clutch cut-off switch ON → Clutch cut-off switch [CS-42(5) ‡ (1)] →  
 → Controller [CN-58(10)‡ (29)] → Service brake applied → Service brake pressure switch  
 ON [CD-5] → T/M control unit [CN-52(66)] → Declutch

### 2) CHECK POINT

Engine	Key switch	Check point	Voltage
Running	ON	<ul style="list-style-type: none"> <li>- GND (Parking switch input)</li> <li>- GND (Parking switch output)</li> <li>- GND (Parking switch input)</li> <li>- GND (Parking switch output)</li> <li>- GND (Parking solenoid)</li> <li>- GND (Pressure switch clutch cut-off)</li> </ul>	20~25V

GND : Ground

# ELECTRIC PARKING, DECLUTCH CIRCUIT

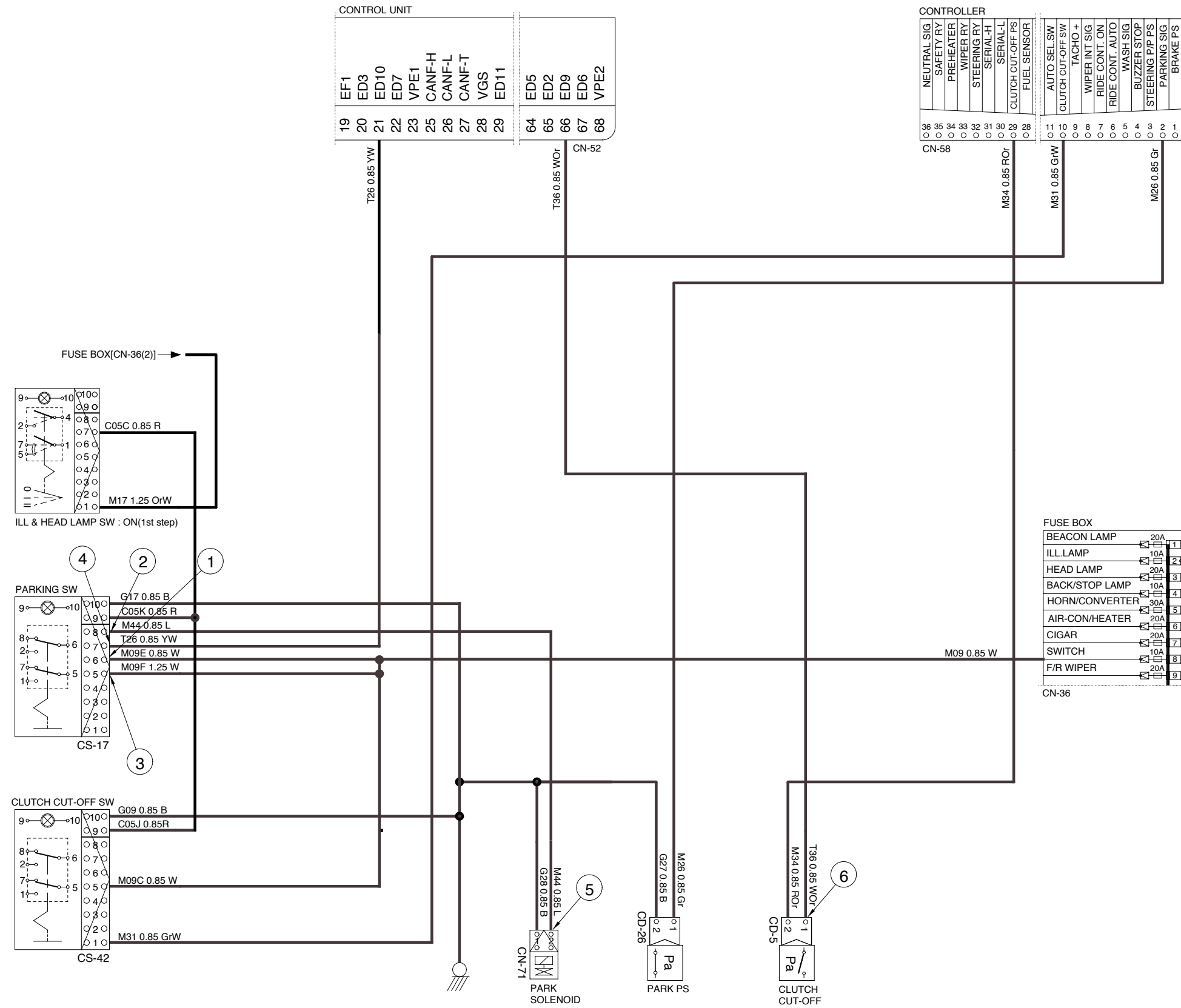

## 7. WIPER AND WASHER CIRCUIT

### 1) OPERATING FLOW

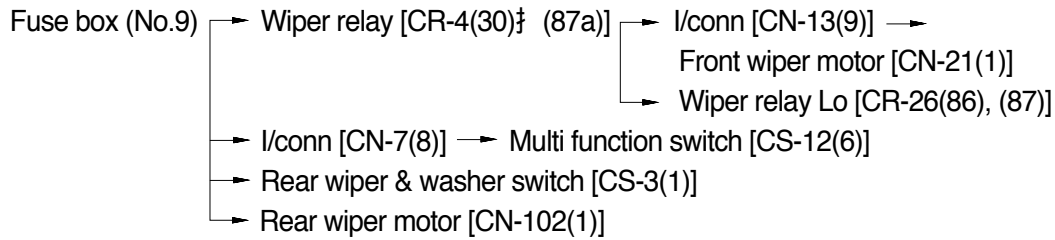

#### (1) Front washer switch ON

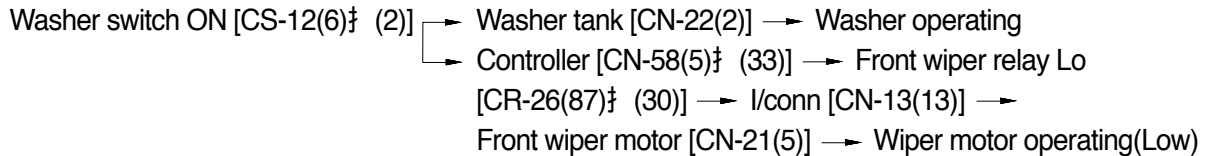

#### (2) Front wiper switch ON

##### INT position

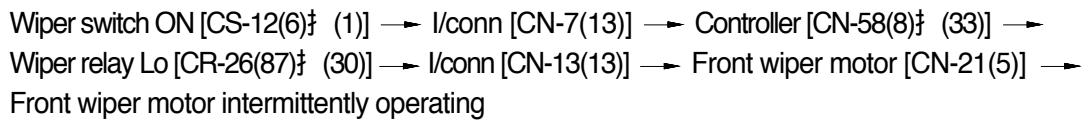

##### Lo position

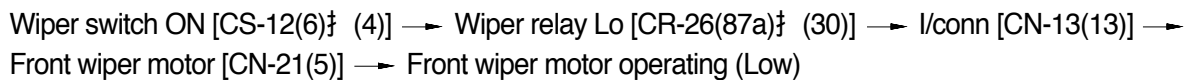

##### Hi position

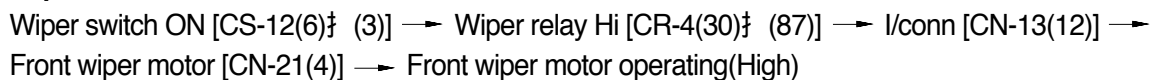

#### (3) Auto-parking(When switch OFF)

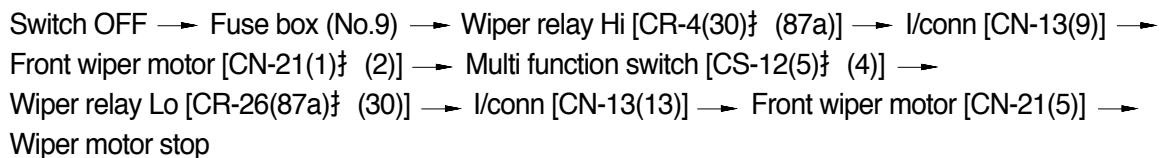

#### (4) Rear wiper and washer switch

##### Wiper switch ON(1st step)

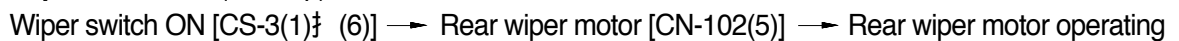

##### Washer switch ON(2nd step)



## 2) CHECK POINT

Engine	Key switch	Check point	Voltage
Stop	ON	<ul style="list-style-type: none"><li>- GND (Front wiper switch power input)</li><li>- GND (Rear wiper switch power input)</li><li>- GND (Wiper relay power input)</li><li>- GND (Front wiper motor Lo power input)</li><li>- GND (Front wiper motor High power input)</li><li>- GND (Wiper relay power input)</li><li>- GND (Front washer power output)</li><li>- GND (Rear washer power output)</li><li>- GND (Front wiper motor power output)</li><li>- GND (Rear wiper motor power output)</li></ul>	20~25V

GND : Ground



# WIPER AND WASHER CIRCUIT

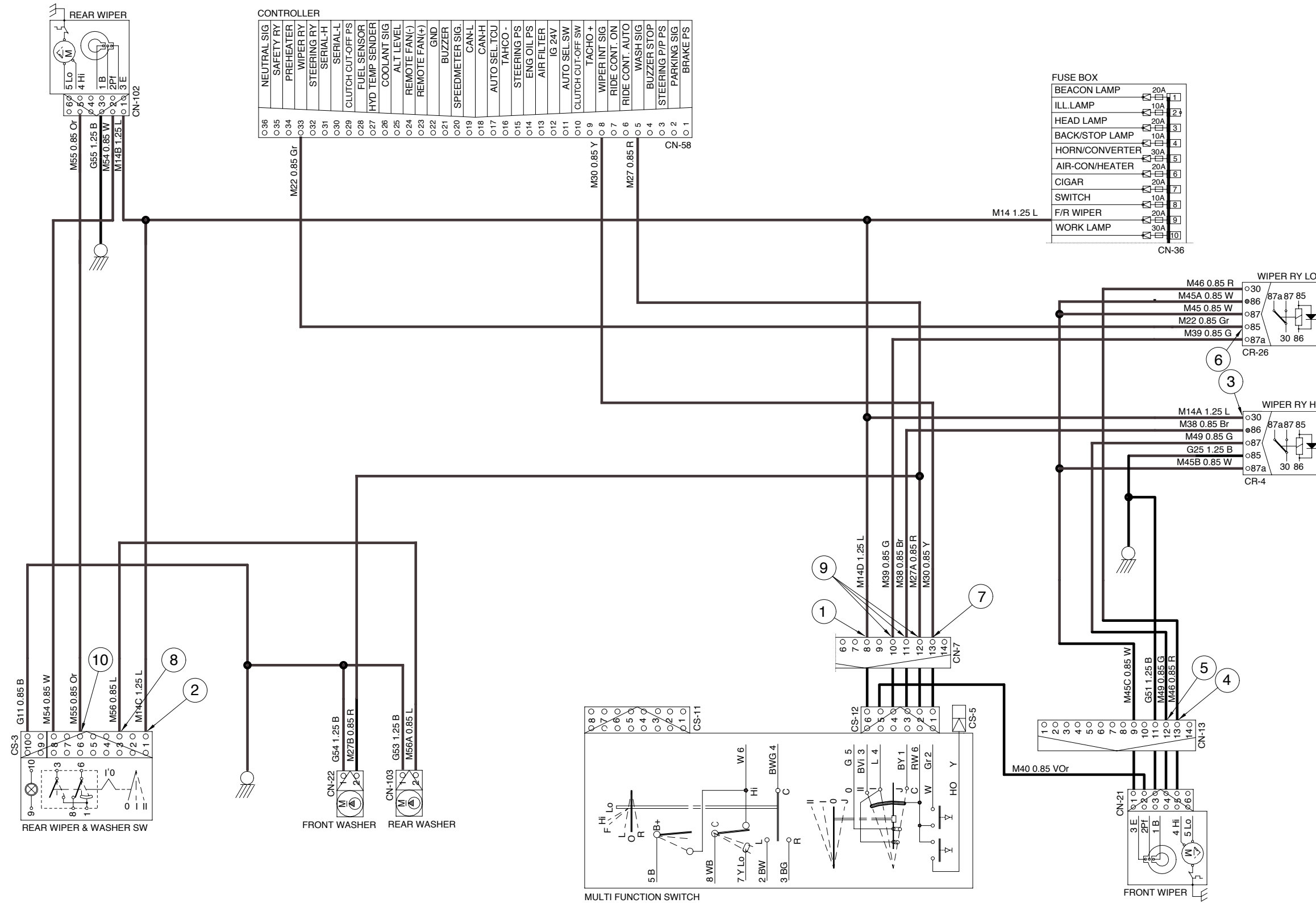

# HAZARD, TURN AND ROTARY CIRCUIT

