

SECTION 3 POWER TRAIN SYSTEM

GROUP 1 STRUCTURE AND FUNCTION

1. POWER TRAIN COMPONENT OVERVIEW

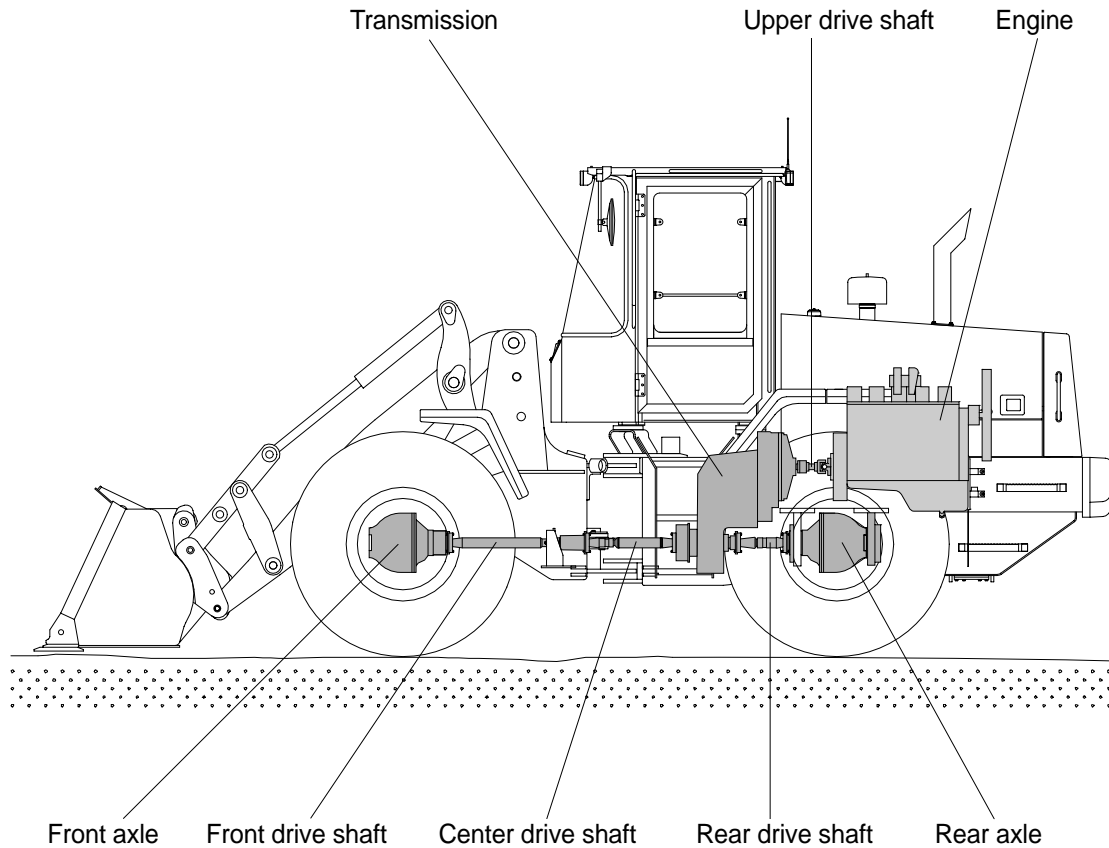

The power train consists of the following components :

- Transmission
- Front, upper, center and rear drive shafts
- Front and rear axles

Engine power is transmitted to the transmission through the torque converter.

The transmission is a hydraulically engaged four speed forward, three speed reverse countershaft type power shift transmission. A disk type parking brake is located on the front of the transmission housing.

The transmission outputs through universal joints to three drive shaft assemblies. The front drive shaft is a telescoping shaft which drives the front axle. The front axle is mounted directly to the loader frame. The front axle is equipped with limited slip differential.

The rear axle is mounted on an oscillating pivot. The rear axle is equipped with limited slip differential.

The power transmitted to front axle and rear axle is reduced by the pinion gear and ring gear of differential. It then passes from the differential to the sun gear shaft(Axle shaft) of final drive.

The power of the sun gear is reduced by a planetary mechanism and is transmitted through the planetary hub to the wheel.

1) HYDRAULIC SCHEMATIC

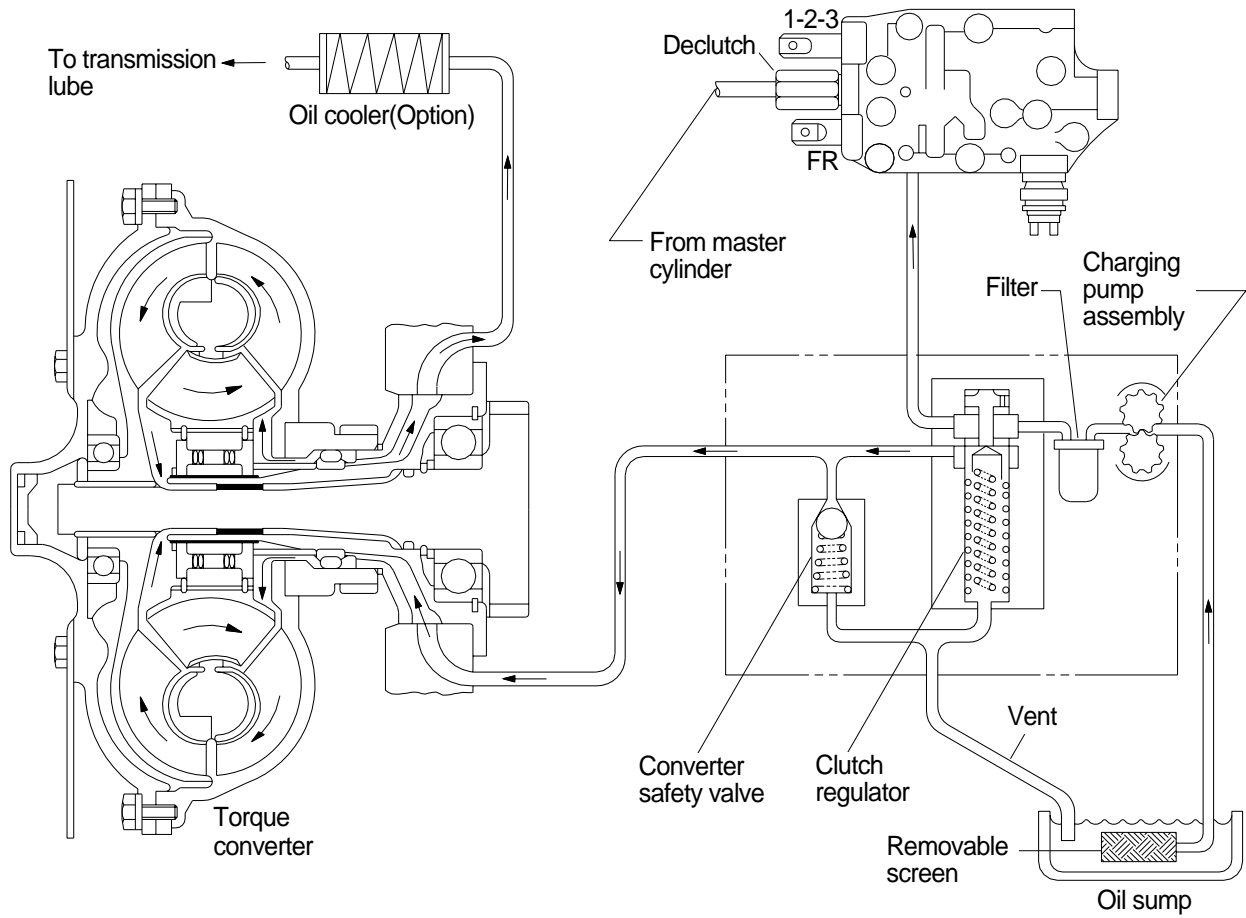

2) HYDRAULIC CIRCUIT

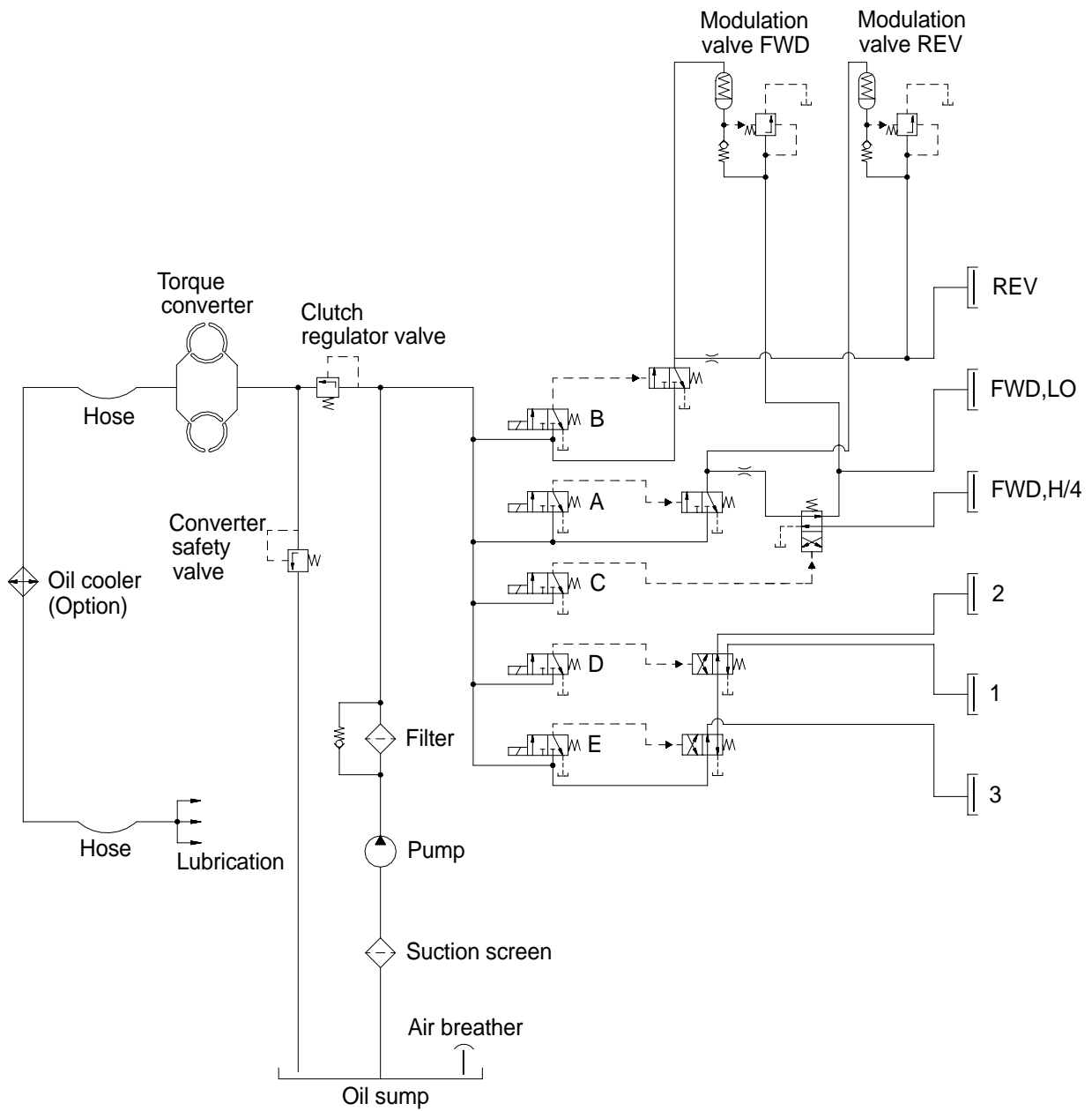

Speed	Forward				Reverse			Neutral		
	1	2	3	4	1	2	3	1	2	3
B					X	X	X			
C				X						
A	X	X	X	X						
E	X	X			X	X		X	X	
D	X				X			X		

X : Solenoid activated

2. TRANSMISSION

1) STRUCTURE

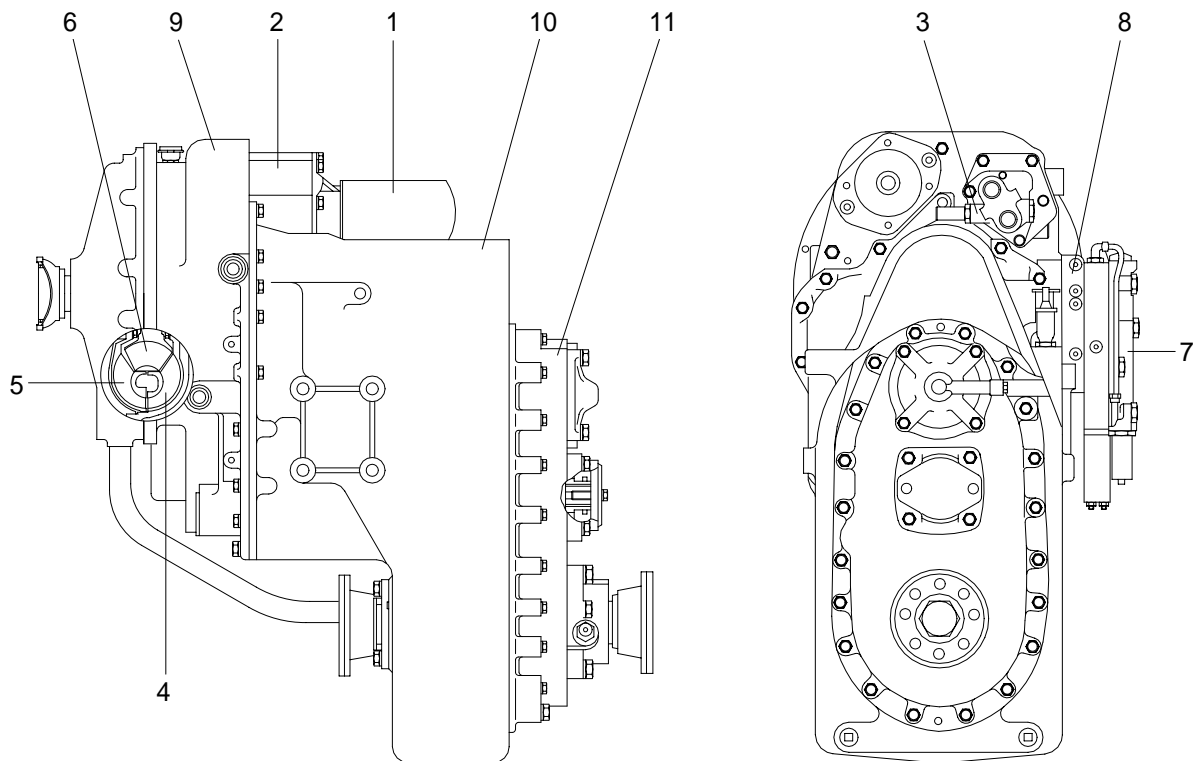

- | | | | | | |
|---|------------------|---|-------------------------|----|-------------------|
| 1 | Filter | 5 | Turbine | 9 | Converter housing |
| 2 | Charging pump | 6 | Stator(Reaction member) | 10 | Transmission case |
| 3 | Regulating valve | 7 | Control valve | 11 | Rear cover |
| 4 | Impeller | 8 | Modulator valve | | |

The transmission is a mid-mount torque converter and transmission assembly connected to the engine by means of a drive shaft.

The control valve assembly(7) mounted directly on the side of the converter housing(9).

The function of the control valve assembly is to direct oil under pressure to the desired directional and speed clutch. A provision is made to neutralize the transmission when the brakes are applied. This is accomplished through use of a brake actuated shutoff valve. The speed and direction clutch assemblies are mounted inside the transmission case(10) and are connected to the output shaft of the converter either by direct gearing or drive shaft. The purpose of the speed or directional clutches is to direct the power flow through the gear train to provide the desired speed range and direction.

2) OPERATION

With the engine running, the converter charging pump(2) draws oil from the transmission sump through the removable oil suction screen and directs it through the oil filter and the pressure regulating valve(3).

The pressure regulating valve maintains pressure to the transmission control cover for actuating the direction and speed clutches. This requires a small portion of the total volume of oil used in the system. The remaining volume of oil is directed through the torque converter circuit to the oil cooler and returns to the transmission for positive lubrication. This regulator valve consists of a hardened valve spool operating in a closely fitted bore. The valve spool is spring loaded to hold the valve in a closed position. When a specific pressure is achieved, the valve spool works against the spring until a port is exposed along the side of the bore. This sequence of events provides the proper system pressure.

After entering the converter housing the oil is directed through the stator support to the converter blade cavity and exits in the passage between the turbine shaft and converter support. The oil then flows out of the converter to the oil cooler. After leaving the cooler, the oil is directed to a lubricating fitting on the transmission and through a series of tubes and passages lubricates the transmission bearings and clutches. The oil then gravity drains to the transmission sump.

The hydraulic torque converter consists basically of three elements and their related parts to multiply engine torque. The engine power is transmitted from the engine flywheel to the impeller element through the impeller cover. This element is the pump portion of the hydraulic torque converter and is the primary component which starts the oil flowing to the other components which results in torque multiplication. This element can be compared to a centrifugal pump in that it picks up fluid at its center and discharges at its outer diameter.

The torque converter turbine(5) is mounted opposite the impeller(4) and is connected to the output shaft of the torque converter. This element receives fluid at its outer diameter and discharges at its center. Fluid directed by the impeller out into the particular design of blading in the turbine and reaction member(6) is the means by which the hydraulic torque converter multiplies torque.

The reaction member of the torque converter is located between and at the center or inner diameters of the impeller and turbine elements. Its function is to take the fluid which is exhausting from the inner portion of the turbine and change its direction to allow correct entry for recirculation into the impeller element.

The torque converter will multiply engine torque to its designed maximum multiplication ratio when the output shaft is at zero RPM. Therefore, we can say that as the output shaft is decreasing in speed the torque multiplication is increasing.

The control valve assembly consists of a valve body with selector valve spools. A detent ball and spring in the selector spool provides one position for each speed range. A detent ball and spring in the direction spool provides three position, one each for forward, neutral and reverse.

With the engine running and the directional control lever in neutral position, oil pressure from the regulating valve is blocked at the control valve, and the transmission is in neutral. Movement of the forward and reverse spool will direct oil, under pressure to either the forward or reverse direction clutch as desired. When either directional clutch is selected the opposite clutch is relieved of pressure and vents back through the direction selector spool. The same procedure is used in the speed selector.

The direction or speed clutch assembly consists of a drum with internal splines and a bore to receive a hydraulically actuated piston. The piston is "**oil tight**" by the use of sealing rings. A steel disc with external splines is inserted into the drum and rests against the piston. Next, a friction disc with splines at the inner diameter is inserted. Discs are alternated until the required total is achieved. A heavy back-up plate is then inserted and secured with a snap ring. A hub with outer diameter splines is inserted into the splines of discs with teeth on the inner diameter. The discs and hub are free to increase in speed or rotate in the opposite direction as long as no pressure is present in that specific clutch.

To engage the clutch, as previously stated, the control valve is placed in the desired position. This allows oil under pressure to flow from the control valve, through a passageway, to a chosen clutch shaft. This shaft has a drilled passageway for oil under pressure to enter the shaft. Oil pressure sealing rings are located on the clutch shaft. These rings direct oil under pressure to a desired clutch. Pressure of the oil forces the piston and discs against the heavy back-up plate. The discs, with teeth on the outer diameter, clamping against discs with teeth on the inner diameter, enables the hub and clutch shaft to be locked together and allows them to drive as a unit.

There are bleed balls or bleed orifices, in the clutch piston which allow quick escape for oil when the pressure to the piston is released.

3. TRANSMISSION

1) TYPICAL CROSS SECTION

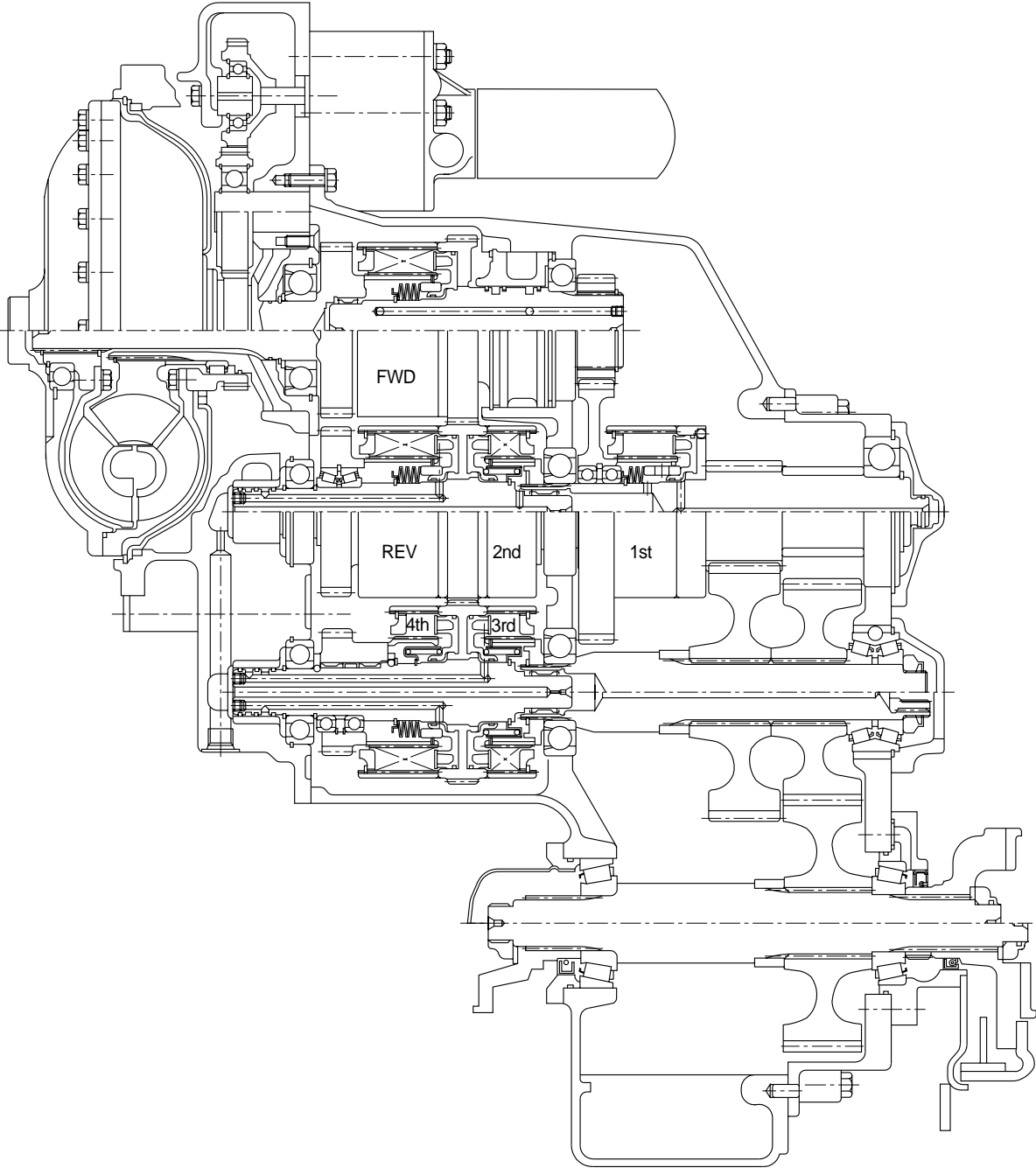

2) TRANSMISSION LAYOUT

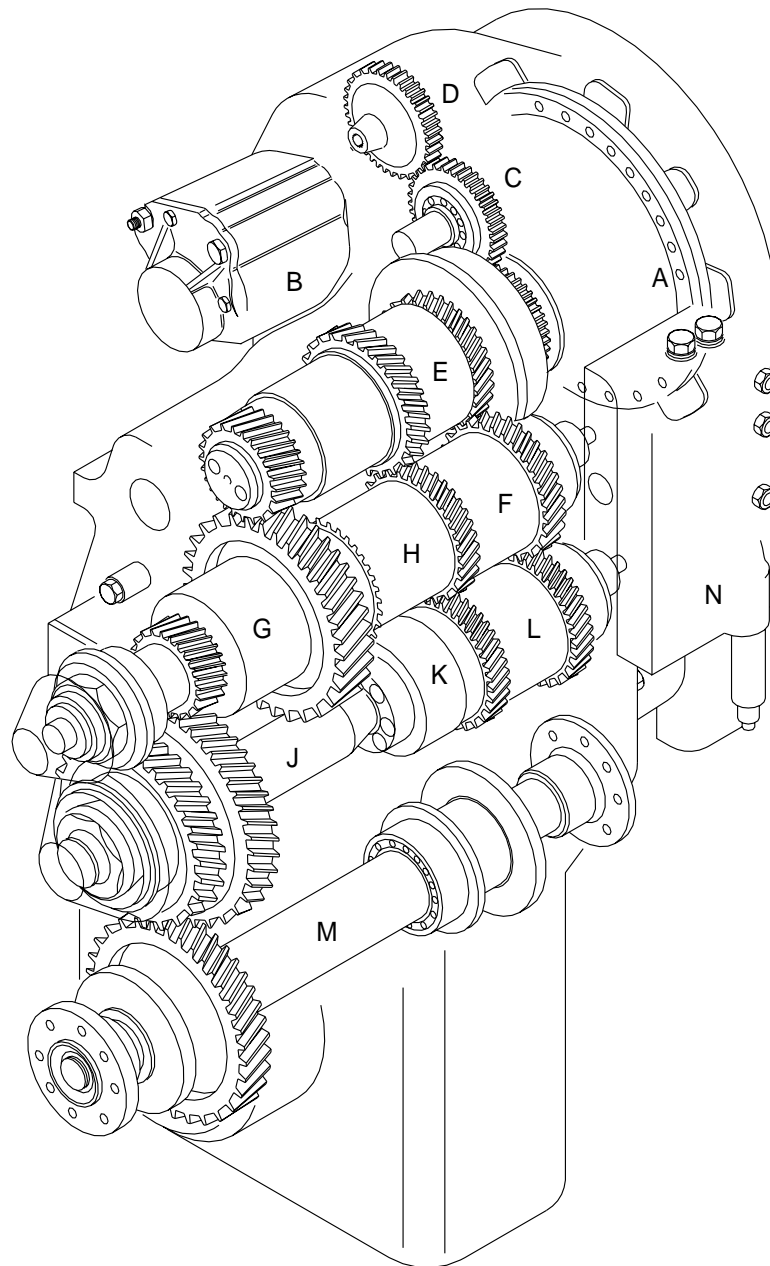

- | | | | | | |
|---|-----------------------|---|----------------|---|------------------------|
| A | Torque converter | F | Reverse clutch | K | 3rd clutch |
| B | Charge pump assembly | G | 1st clutch | L | 4th clutch |
| C | Pump drive idler gear | H | 2st clutch | M | Output shaft |
| D | Pump drive gear | J | Idler shaft | N | Solenoid control valve |
| E | Forward clutch | | | | |

3) OPERATION OF TRANSMISSION

(1) Forward

① Forward 1st

In 1st forward, forward clutch and 1st clutch are engaged.

Forward clutch and 1st clutch are actuated by the hydraulic pressure applied to the clutch piston.

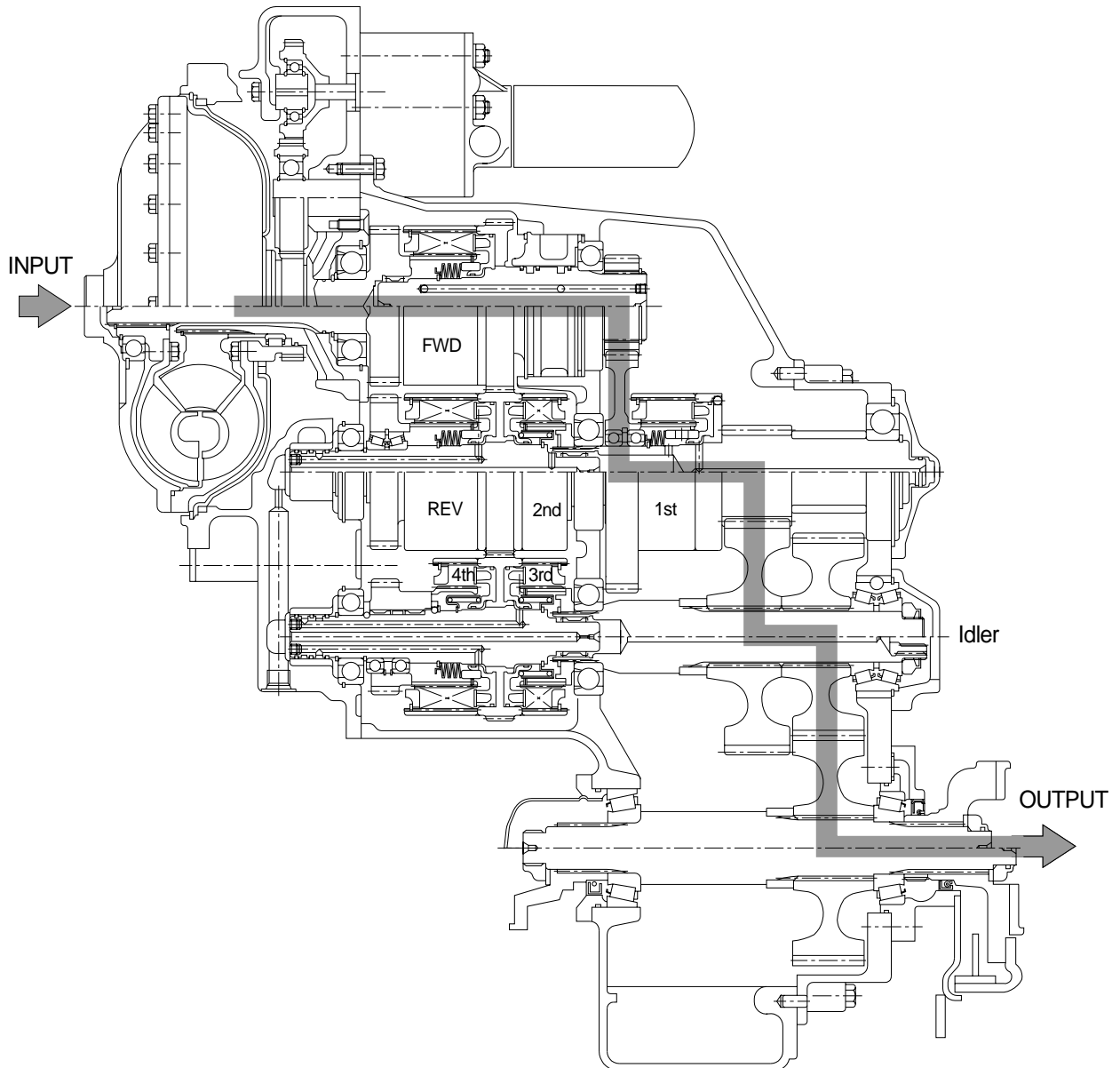

② Forward 2nd

In 2nd forward, forward clutch and 2nd clutch are engaged.

Forward clutch and 2nd clutch are actuated by the hydraulic pressure applied to the clutch piston.

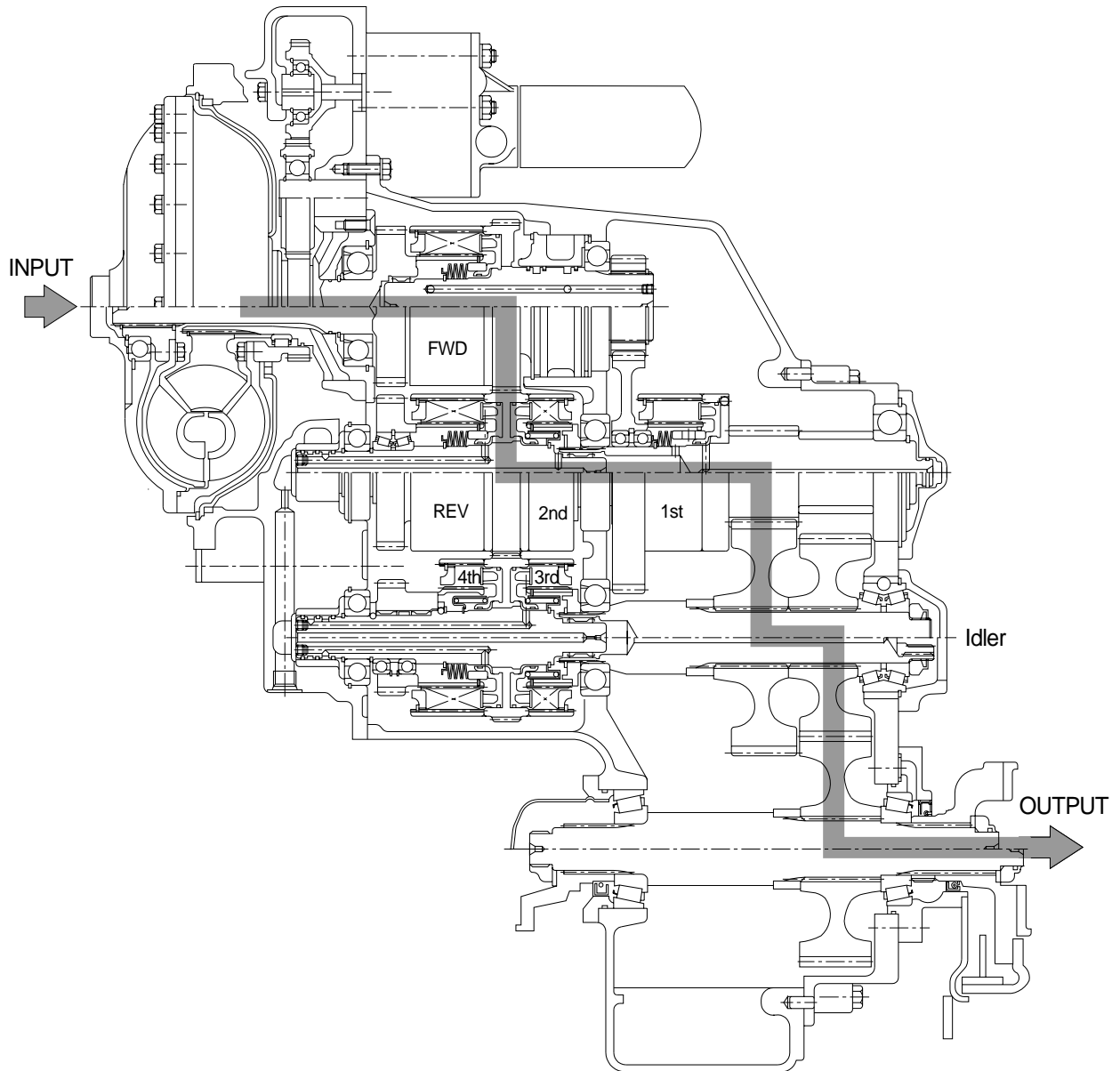

④ Forward 4th

In 4th forward, 4th clutch and 3rd clutch are engaged.

4th clutch and 3rd clutch are actuated by the hydraulic pressure applied to the clutch piston.

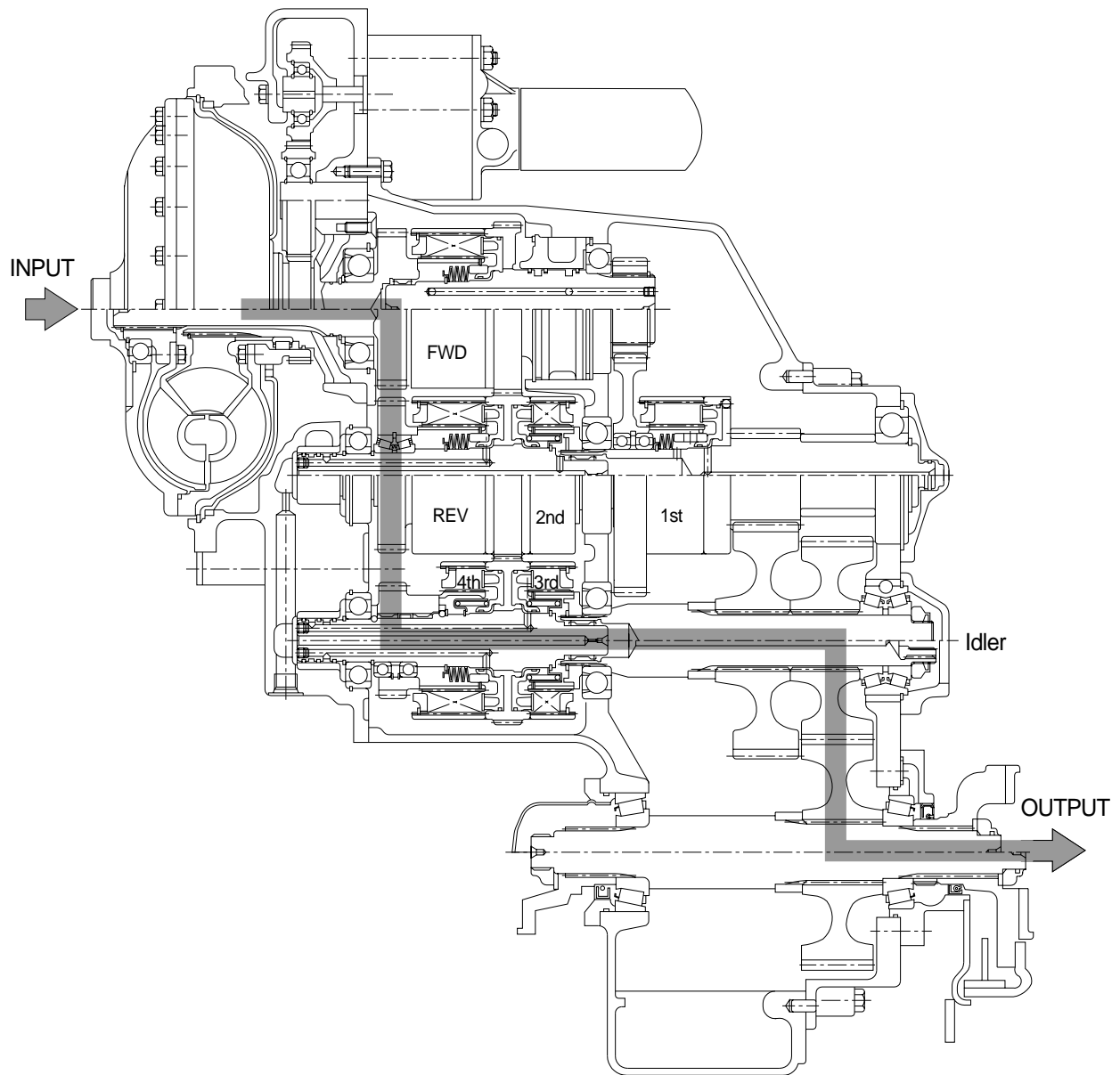

(2) Reverse

① Reverse 1st

In 1st reverse, reverse clutch and 1st clutch are engaged.

Reverse clutch and 1st clutch are actuated by the hydraulic pressure applied to the clutch piston.

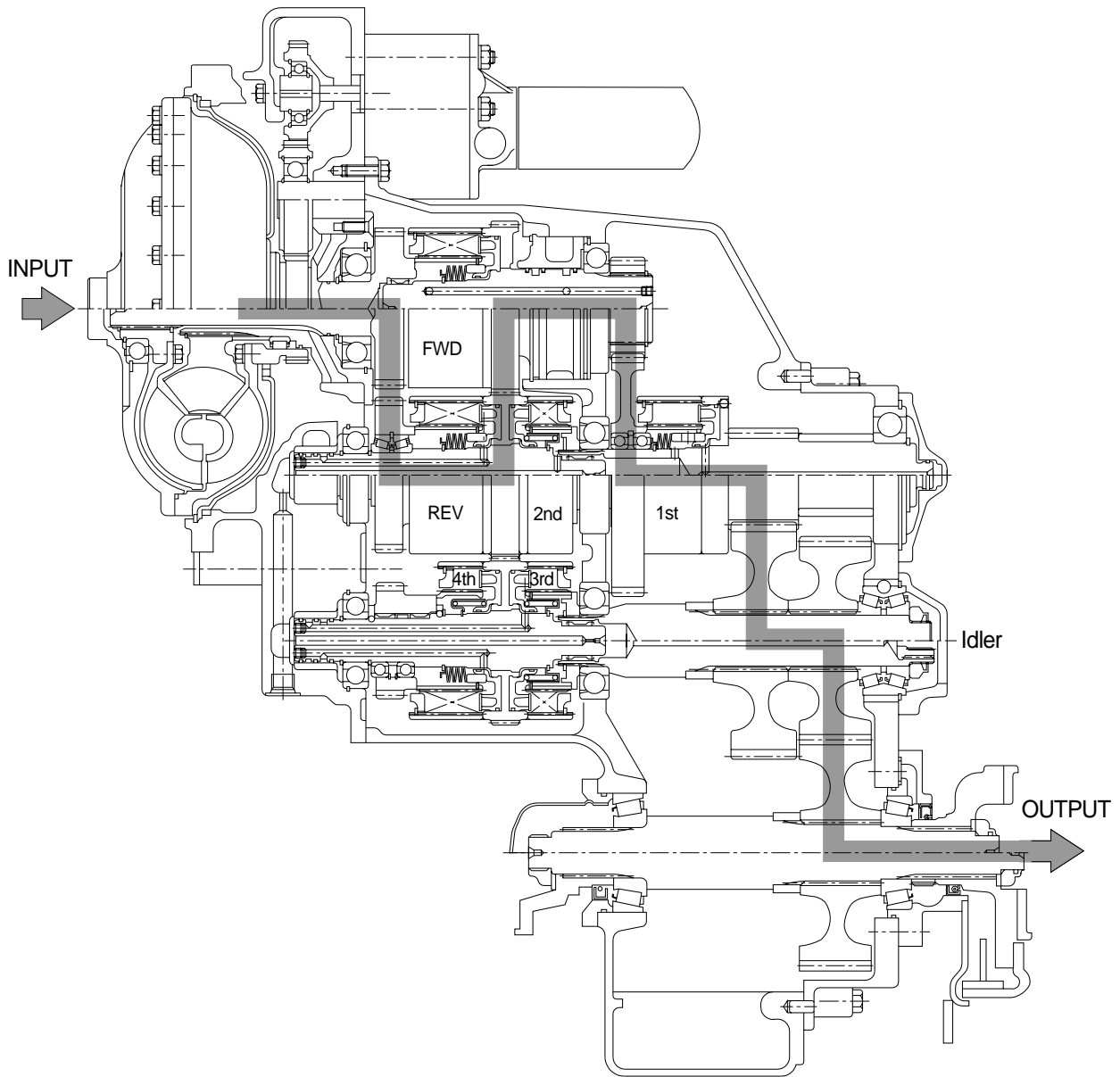

② Reverse 2nd

In 2nd reverse, reverse clutch and 2nd clutch are engaged.

Reverse clutch and 2nd clutch are actuated by the hydraulic pressure applied to the clutch piston.

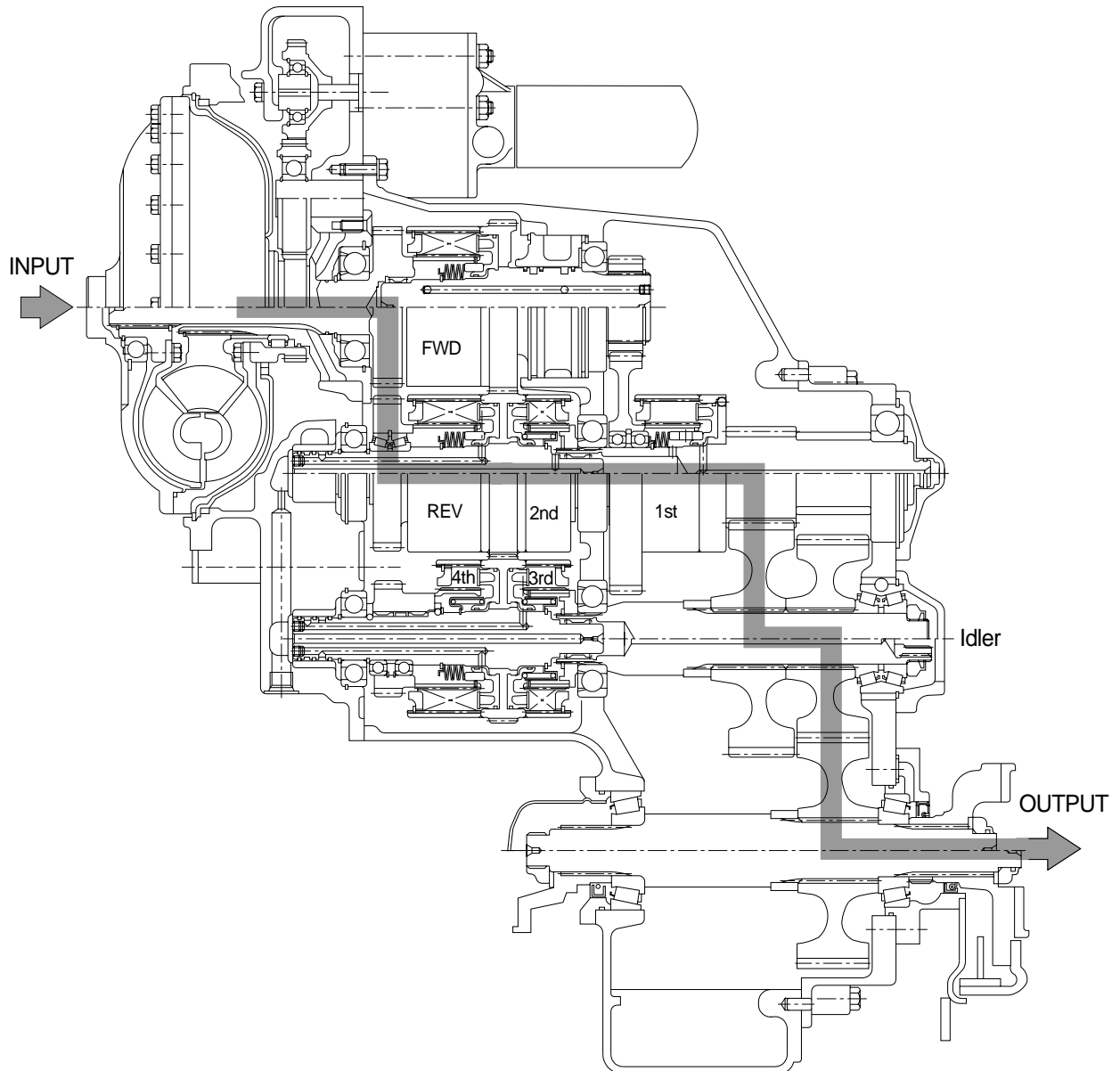

③ Reverse 3rd

In 3rd reverse, reverse clutch and 3rd clutch are engaged.

Reverse clutch and 3rd clutch are actuated by the hydraulic pressure applied to the clutch piston.

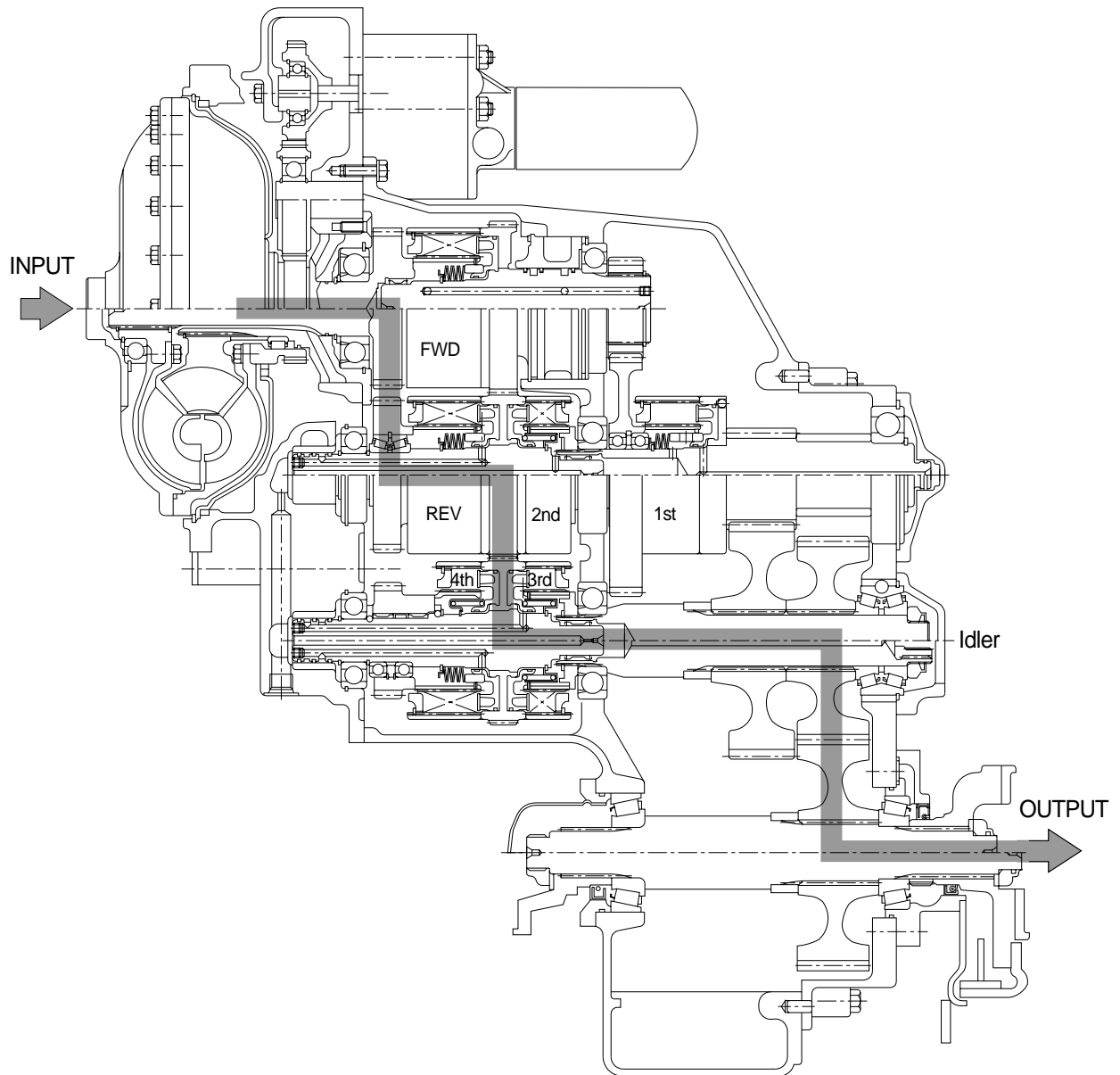

4) ELECTRIC SOLENOID CONTROL VALVE

Direction & speed	Solenoids energized	Clutches pressurized
Forward 1st	V X Y	Forward & 1st
Forward 2nd	V X	Forward & 2nd
Forward 3rd	V	Forward & 3rd
Forward 4th	V Z	4th & 3rd
Reverse 1st	W X Y	Reverse & 1st
Reverse 2nd	W X	Reverse & 2nd
Reverse 3rd	W	Reverse & 3rd

Pilot and clutch pressure check points

1P	1st pilot
2P	2nd pilot
2C	2nd clutch
4P(FHP)	4th clutch
RP	Reverse pilot
RC	Reverse clutch

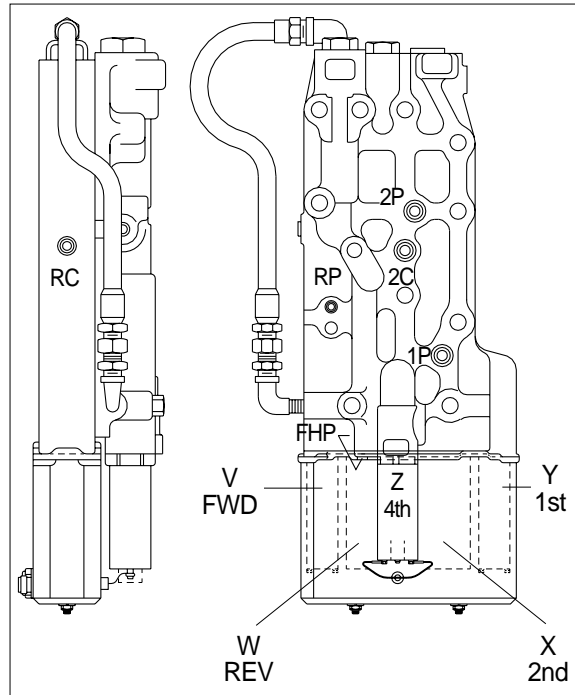

Energized

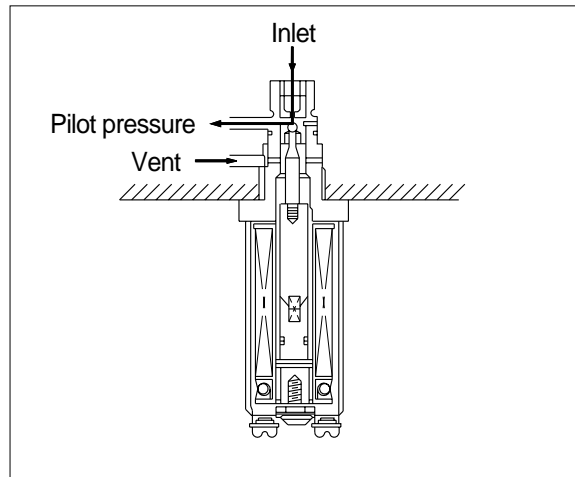

De-energized

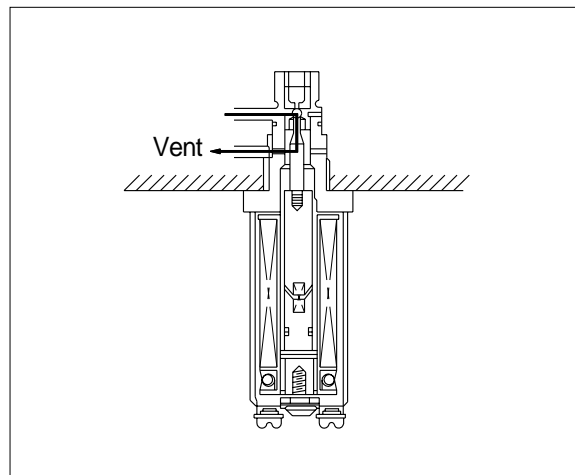

4. EGS LEVER

1) SHIFT LEVER OPERATION

EGS lever applications share the principle of selecting direction and gear positions.

Direction is selected by placing the lever in **one of three detented positions**(Neutral, Forward or Reverse).

Gear shifts are made by bringing the lever either in the **upshift position** or in the **downshift position**. These positions are **spring returned**.

With the EGS, shifts are made **relative** to the previous position : The EGS **remembers** the selected gear position and shifts either to a higher gear or to a lower gear.

The EGS display always shows the selected shift lever position, the selected direction, the gear position and the gear direction.

This operating principle accounts for the flexibility of the EGS system : It makes possible to control any(Electric) powershift transmission with the same shift lever, provided the correct **software**(A program for the EGS computer) is installed.

It also facilitates features such as kickdown, automatic powerup in neutral, preset gear selection after a direction change, etc..

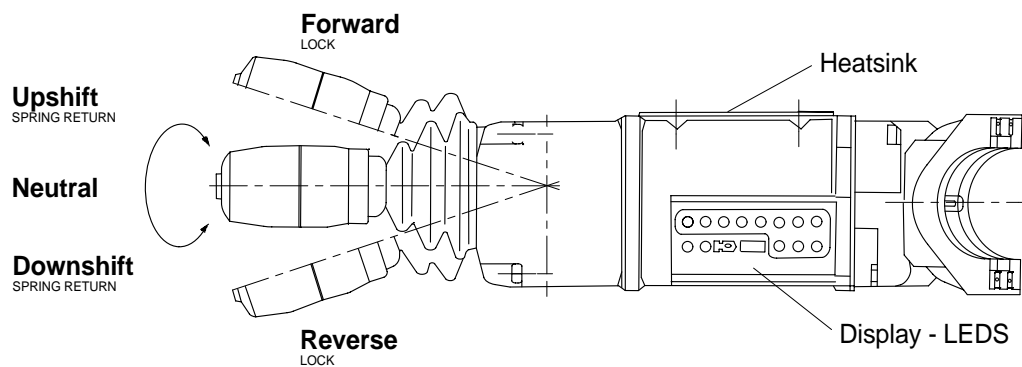

The **forward** driving direction is selected by pushing the lever away from the driver(This usually corresponds with pushing it to the normal driving direction).

The **reverse** driving direction is selected by pulling the lever towards the driver.

The **neutral** can be selected by placing the lever into its central detented position.

An **upshift** is requested by rotating the shift lever counter clockwise.

A **downshift** is requested by rotating the shift lever clockwise.

2) FUNCTIONAL DESCRIPTION

(1) Automatic powerup in neutral

When power is first applied to the EGS, **neutral** is always selected.

This is **regardless** of the position of the shift lever(It can be in either forward, neutral or reverse position).

In order to start driving, the driver first has to place the shift lever into the neutral(Central detented) position before a specific direction can be selected.

(2) Neutral start protection

Each EGS can have an output signal, which is deactivated whenever the shift lever is in the neutral position.

This signal can be used to control a normal closed relay preventing engine start up whenever the shift lever is **not** in the neutral detented position.

If during powerup the shiftlever is in forward or in reverse, the neutral start protection will not be activated(Due to the function **automatic powerup in neutral**). Only after leaving this function **automatic powerup in neutral** the neutral start protection will be activated.

(3) Kickdown

This EGS lever is also available with a shift lever integrated **push button**, which is used for the kickdown function.

Usually it's used for requesting a downshift from 2nd to 1st gear, which is dropped after a direction change : **F2→Kickdown→F1→R2**

This is called kickdown.

If however the speed is too high, the kickdown request is stored for a certain time. If during this time the speed has not slowed down sufficiently, the request is dropped.

3) DISPLAY FUNCTION

The EGS has an internal bicolor LED display for displaying the selected shiftablever position, the selected shiftablever direction, the transmission position and the transmission direction.

Application specific details are described in a separate document : EGS functional description.

This EGS functional description can be requested for each EGS unit. This description overrules the below description wherever applicable.

(1) Displayed information

Typically four types of information about the EGS and the transmission can be of interest to the driver :

Selected shiftablever position and transmission position

Selected shiftablever direction and transmission direction

Application specific information

Diagnostic information

① Selected position and direction

The difference between shift lever position and transmission position might not be immediately clear, but when one remembers that the EGS can protect the transmission(Example : By not allowing a downshift), it becomes clear that the **requested** position(The shift lever position) can be different from the **actual engaged** position(The position of the transmission).

Both shift lever position and transmission position can be divided in two subcategories:

Gear position (1st, 2nd, 3rd, 4th)

Driving direction (Forward, neutral, reverse)

Application specific information

This can be anything(Whatever the customer wants to see).

As an example : On an EGS automatically controlling the lockup clutch, it's interesting to see whether or not the converter is in lockup. This can be indicated on the EGS display by using the LED 7-yellow.

② Diagnostic information

Two types of diagnostic information are considered :

ON LINE diagnostics

This information is given during normal driving when something special happens.

In most applications, the LED 8 is used to indicate standstill. This helps to spot problems with the speed sensor in an early stage before the lack of protection resulting from the failure can produce damaged to the drivetrain.

Which **on line** diagnostic functions are provided is detailed in the application specific EGS Functional description.

OFF LINE diagnostics

There are three selftest modes built into the EGS. Details about their function and usage are described in clause 5), **Selftest functions**.

(2) Display layout

The EGS uses LED's(Light Emmitting Diodes) to give information to the driver.

It consists of eight multicolor LED's :

Labelled 1 to 8 and can light up in **red, green** and **yellow**.

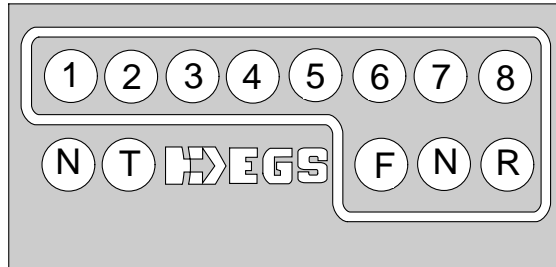

These numbered LED's are used for displaying both the shift lever selection and the transmission engagement.

They also used to indicate diagnostic information in the different test modes.

The **red** LED is labelled **N** and when this lights up it indicates that the transmission is placed in neutral(This is possible even while the shift lever is not in neutral).

The **yellow** LED is labelled **T** which stands for troubleshooting. This LED is ON while working in one of the three selftest modes described in clause 5), **Selftest function**.

(3) Display method

Basically the **gear position** is shown by turning ON the LED that corresponds with the selected position. In 1st gear, LED 1 is ON, in 2nd gear, LED 2 is ON etc..

The selected direction is shown with the **color** of the LED :

Red	Indicates	Neutral
Green	Indicates	Forward
Yellow	Indicates	Reverse

Additionally LED **N**(Red) is ON while the transmission is in neutral.

The position shown is **always** the selected **shiftlever** position. Most of the time, the actual transmission position will be the same as the shown one, and in that case that's all there is.

However if, because of an active protection or because of some internally generated delay, there is a discrepancy between transmission position and shift lever position, a 2nd LED will indicate the transmission position(Color indicates direction).

To let the driver know the difference between both indications, the transmission LED blinks while the shift lever LED stays ON all the time.

While this may seem a bit confusing at first, it's very easy to understand the shown information in reality.

Example : Driving in 4th gear forward at high speed.

→ LED 4 - Green

When the driver is making a downshift, but due to a too high speed the EGS will protect the transmission and will not allow the requested downshift. Thus the transmission will stay in 4th gear forward, while the shiftlever is in 3rd gear forward.

→ LED 3 - Green &
LED 4 - Blinking green

4) CONNECTOR PIN DESIGNATIONS

Below table lists the function of each EGS connector pin for the transmission :

Pin	Comment
1	Battery plus
2	Battery ground
3	Neutral start signal
4	CV Solenoid 1
5	CV Solenoid 2
6	CV Forward solenoid
7	CV Reverse solenoid
8	Null
9	Speed 5km/hr
10	Speed sensor input HOT
11	Speed sensor input GND
12	Travel speed signal
13	CV High / Low solenoid
14	Declutch
15	Extension kick down
16	Shield ground(Internally connected to wire 2)

CV stands for control valve.

5) SELFTEST FUNCTIONS

The EGS has special circuitry to help verifying its operation.

Three selftest modes are built into the EGS control programs :

Input test

Speed sensor test + Lamptest

Output test

The EGS furthermore has the ability to check for possible problems while driving(**On line** diagnostics).

As described in clause(2), Display layout at page 3-18, the **T** LED is used for identifying different troubleshooting modes. This is done in combination with the status of the **N** LED.

(1) Operation of the N and T LED's

① Overview

Situation	LED
In normal situations(Driving, no problems)	T LED is always OFF
When error is detected	T LED is ON or BLINKING
In selftest mode	T LED is always ON

② Detailed operation

Situation	N LED	T LED
Normal operation	On when transmission neutral	OFF
Internal fault	ON	Blinking SLOWLY
Input test	Blinking SLOWLY	ON
Output test	Blinking FAST	ON
Speed sensor test	OFF	ON

(2) Selftest operation

Selftest modes can only be started **while powering up** the EGS.

Invocation of a certain mode is done by moving the shift lever to a specific position while switching on the power of the EGS.

Leaving the selftest mode is done by switching OFF the power of the EGS.

① Selftest mode invocation

Below table lists what conditions must be satisfied during **powerup** to get into a specific selftest mode :

Selftest mode	To enter mode
Input test	FWD & UP
Speed sensor test	REV & UP
Output test	FWD & DOWN

② Input test

When EGS shiftlever is held in the **forward up** position while power is applied, **input test** mode is activated.

In this mode, driving is not possible, since all EGS outputs remain OFF until the testmode is left.

This test is used to verify operation of the shiftlever and its inputs.

The LED's(Gear position indicators) on the EGS top cover are used to display test information :

Shift lever position	LED Color	LED Number
Neutral	RED	4
UP	RED	5
DOWN	RED	3
FWD	GREEN	4
FWD & UP	GREEN	5
FWD & DOWN	GREEN	3
REV	YELLOW	4
REV & UP	YELLOW	5
REV & DOWN	YELLOW	3
Wire 14 = GROUND	RED	1 (Together with above LED)
Wire 15 = GROUND	GREEN	1 (Together with above LED)

※ If wire 14 and wire 15 are grounded simultaneously LED 1 lights up **yellow**.

③ Speed sensor test

When EGS is held in the reverse up position while power is applied, **speed sensor test** mode is activated.

In this mode, driving is possible.

The test begins with a **lamp test** and then displays the speed sensor information.

④ Speed display

The LED corresponding with below table burns to indicate converter turbine speed :

Turbine rpm	LED Number(Green)
0	1 BLINKS
0 - 249	1 ON
250 - 499	2 ON
500 - 749	3 ON
750 - 999	4 ON
1000 -1249	5 ON
1250 - 1499	6 ON
1500 - 1749	7 ON
1750 -1999	8 ON
Above 2000	8 BLINKS

② Output test

When EGS is held in the forward down position while power is applied, **output test** mode is activated.

In this mode, driving is not possible, since all EGS outputs remain OFF until the testmode is left.

LED's 1 - 8 light up sequentially during output test :

First LED 1 is switched on shortly, then LED 2 etc..

When LED 8 is switched off, LED 1 is again switched on and so on.

The color of the LED indicates its status :

Color	Status
GREEN	Output OK
YELLOW	Output NOT connected or shorted to battery plus
RED	Output shorted to ground(or to another output)

The LED numbers correspond to output wires as follows :

LED Number	Output wire
1	6
2	7
3	4
4	5
5	9
6	13
7	8
8	3

※ To find the function of the corresponding output wires - See EGS functional description

6) REPLACING OF EP-ROM

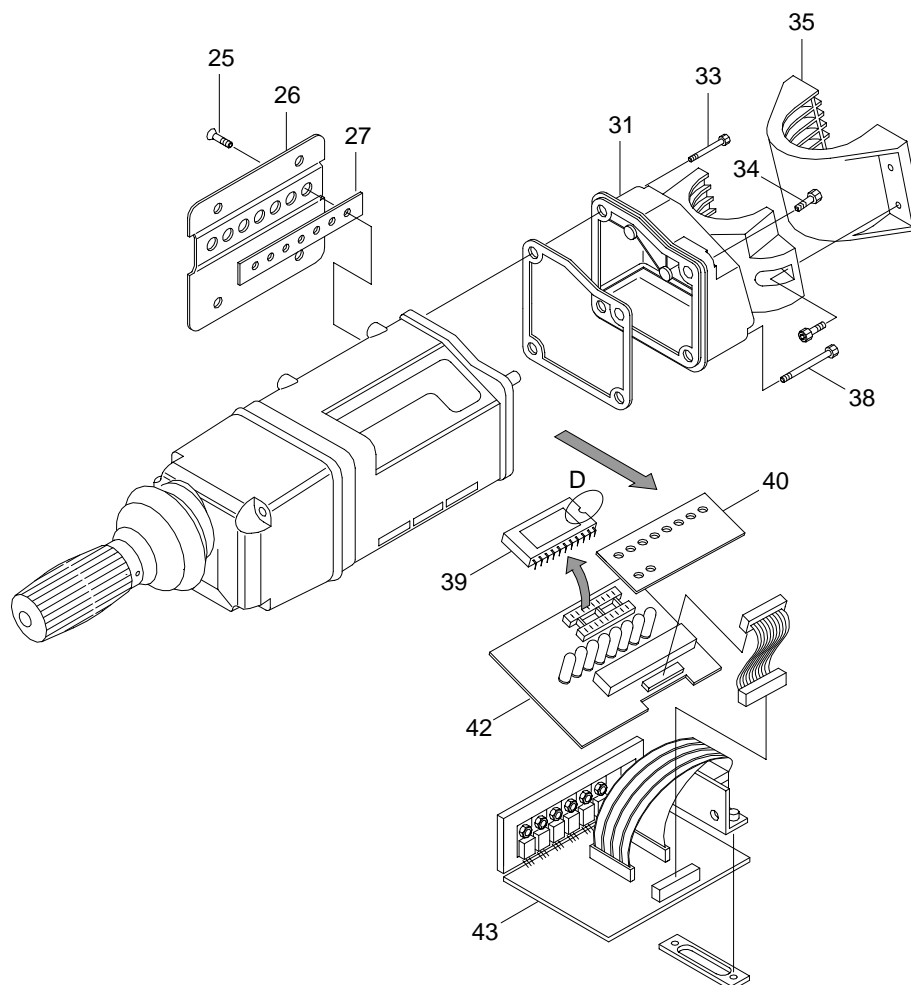

- (1) Remove screw(33).
- (2) Remove screw(38).
- (3) Remove screw(34).
- (4) Remove screw(25).
- (5) Remove plate(26) and seal(27).
- (6) Slide the PCB's(42, 43) out of the housing, with rear cover connected(31, 35).
- (7) Remove plastic cover(40).
- (8) Replace EP-ROM(39).
- ※ **Notice the correct position of the mark on the EP-ROM (See D).**
- (9) Reassemble the EGS.
- ※ **Notice the correct slots for the different ports.**

See on the right figure.

- A : Slots for cover(40)
- B : Slots for PCB(42)
- C : Slots for PCB(43)

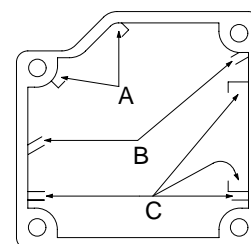

2) SECTION OF FRONT AXLE DIFFERENTIAL

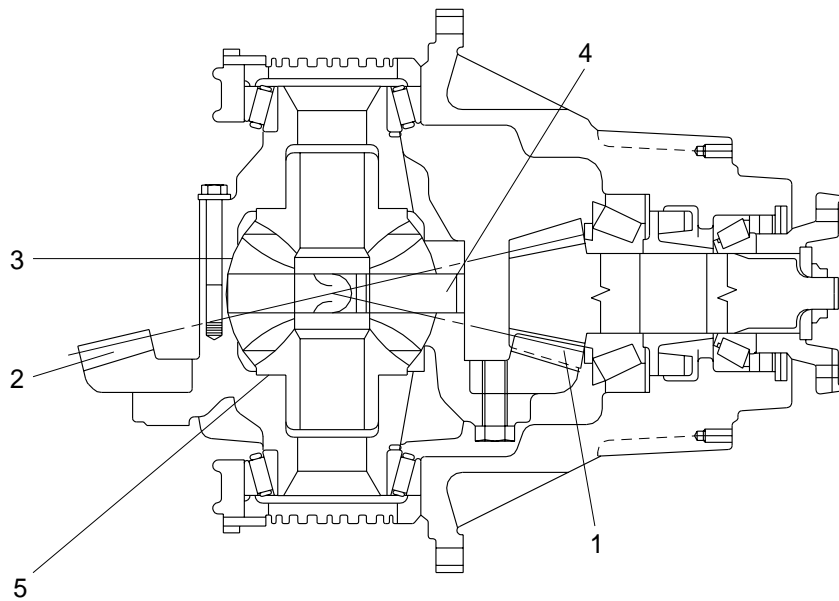
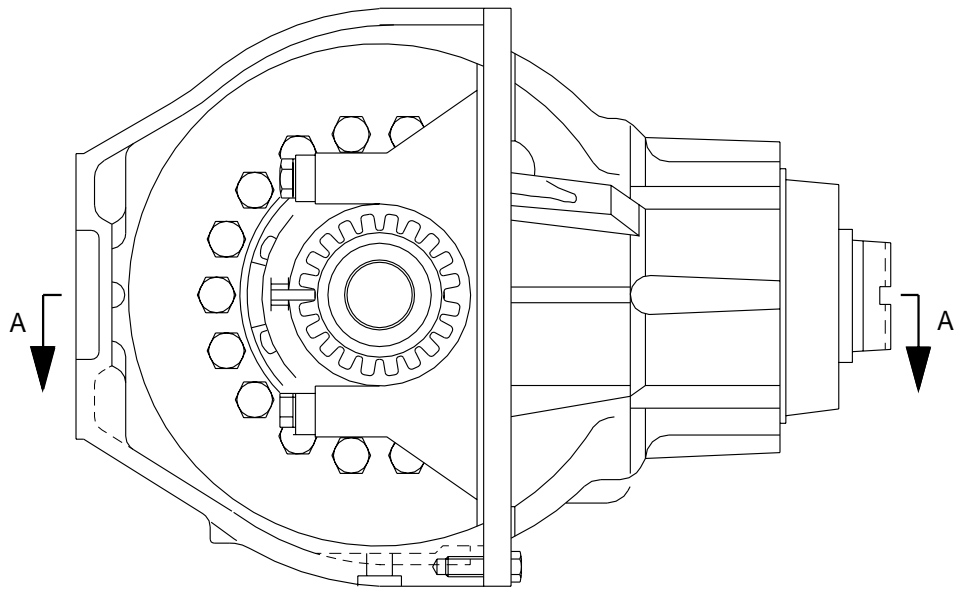

1 Bevel pinion
2 Bevel gear

3 Sun gears
4 Shaft

5 Side gear(Differential)

3) SECTION OF REAR AXLE DIFFERENTIAL

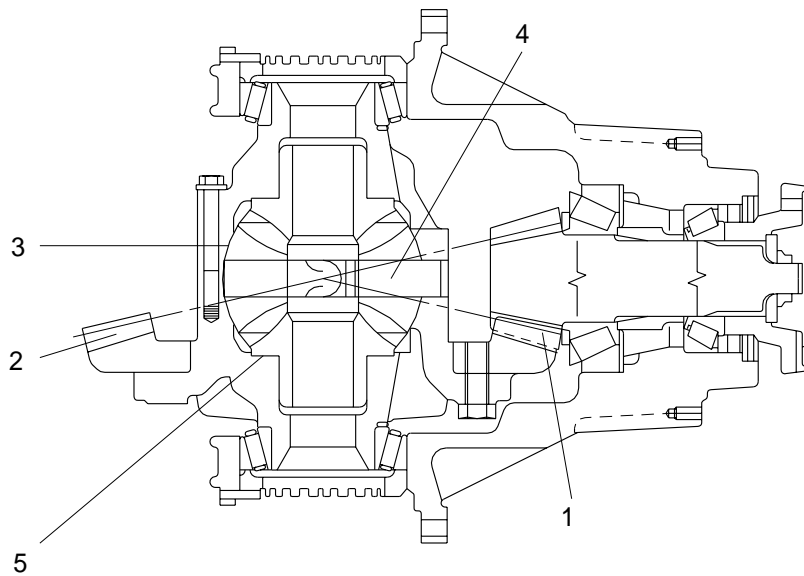
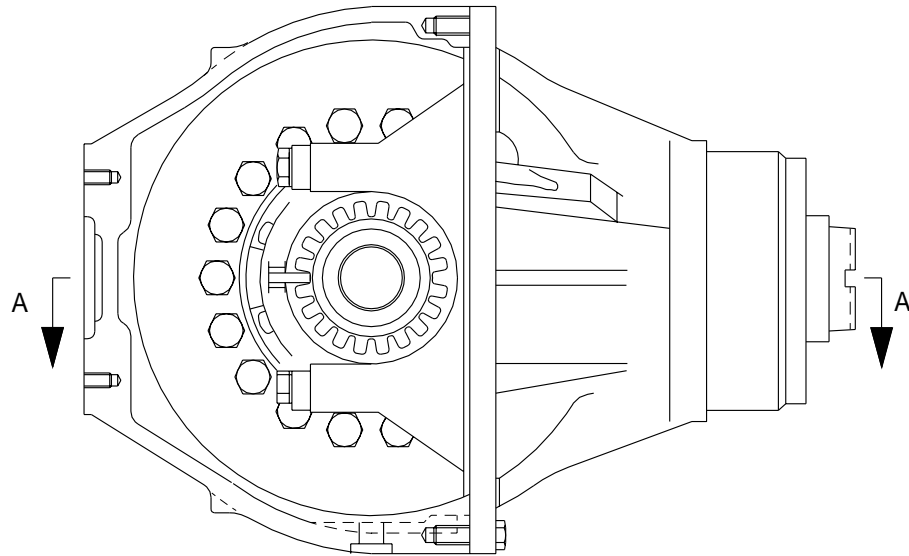

- | | | | | | |
|---|--------------|---|----------|---|-------------------------|
| 1 | Bevel pinion | 3 | Sun gear | 5 | Side gear(Differential) |
| 2 | Bevel gear | 4 | Shaft | | |

4) DIFFERENTIAL

(1) Description

When the machine makes a turn, the outside wheel must rotate faster than the inside wheel. A differential is a device which continuously transmits power to the right and left wheels while allowing them to turn at different speeds, during a turn.

The power from the drive shaft passes through bevel pinion(1) and is transmitted to the bevel gear(2). The bevel gear changes the direction of the motive force by 90°, and at the same time reduces the speed.

It then transmits the motive force through the differential(3) to the axle gear shaft(4).

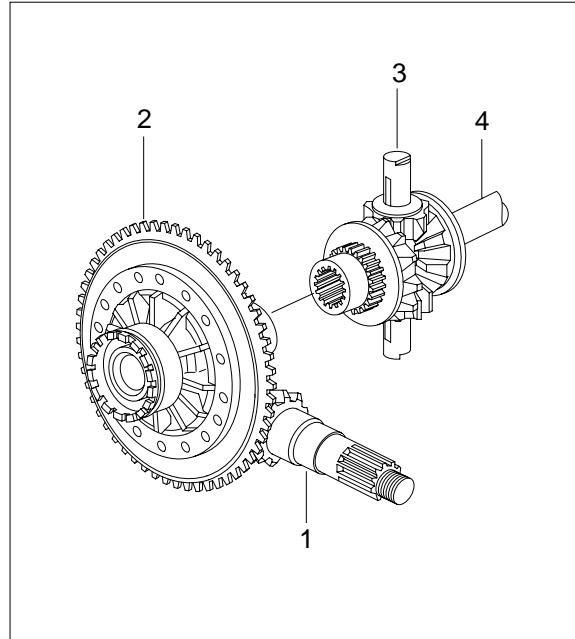

(2) When driving straight forward

When the machine is being driven straight forward and the right and left wheels are rotating at the same speed, so the pinion gear inside the differential assembly do not rotate. The motive force of the carrier is sent through the pinion gear and the side gear, therefore the power is equally transmitted to the left and right axle gear shaft.

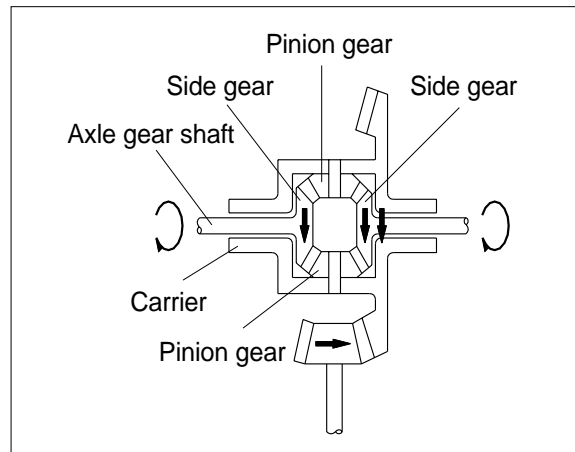

(3) When turning

When turning, the rotating speed of the left and right wheels is different, so the pinion gear and side gear inside the differential assembly rotate in accordance with the difference between the rotating speed of the left and right wheels.

The power of the carrier is then transmitted to the axle gear shafts.

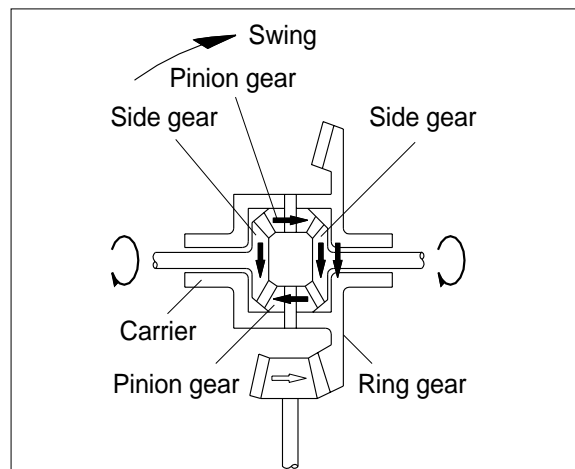

5) TORQUE PROPORTIONING DIFFERENTIAL

(1) Function

① Because of the nature of their work, 4-wheel-drive loaders have to work in places where the road surface is bad.

In such places, if the tires slip, the ability to work as a loader is reduced, and also the life of the tire is reduced.

The torque proportioning differential is installed to overcome this problem.

In structure it resembles the differential of an automobile, but the differential pinion gear has an odd number of teeth. Because of the difference in the resistance from the road surface, the position of meshing of the pinion gear and side gear changes, and this changes the traction of the left and right tires.

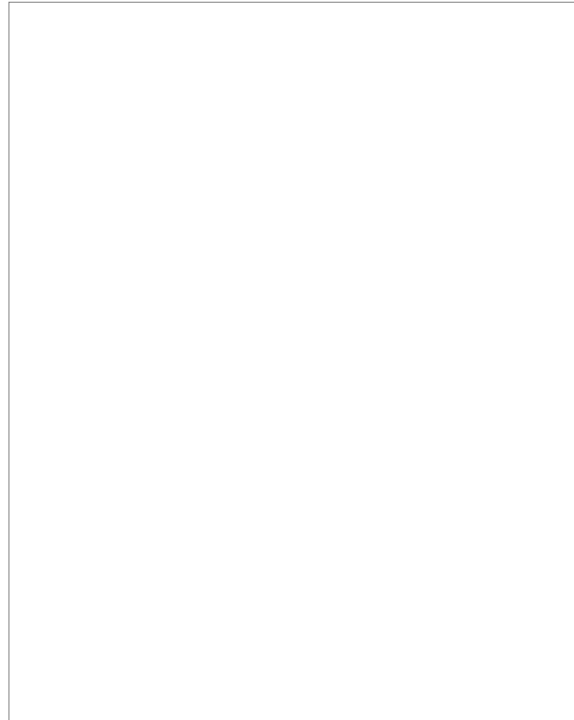

(2) Operation

① **When travelling straight**(Equal resistance from road surface to left and right tires)

Under this condition, the distances involving the engaging points between right and left side gears and pinion-a and b-are equal and the pinion is balanced as $FL \times a = FR \times b$. Thus, $FL = FR$, and the right and left side gears are driven with the same force.

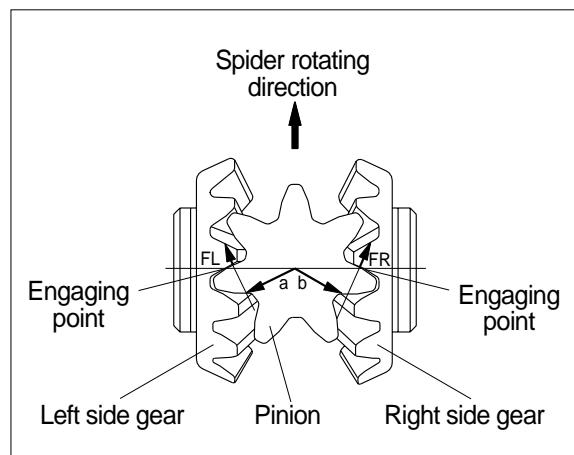

② **When travelling on soft ground**

(Resistance from road surface to left and right tires is different)

If the road resistance to the left wheel is smaller, the left side gear tends to rotate forward, and this rotation changes the engaging points between the side gears and pinion. As a result, the distances involving the engaging points becomes $a > b$. The pinion now is balanced as $FL \times a = FR \times b$, where $FL > FR$. The right side gear is driven with a greater force than the left side gear. The torque can be increased by up to about 30% for either side gear.

The pinion therefore does not run idle and driving power is transmitted to both side gears until the difference between road resistance to the right and left wheels reaches about 30%.

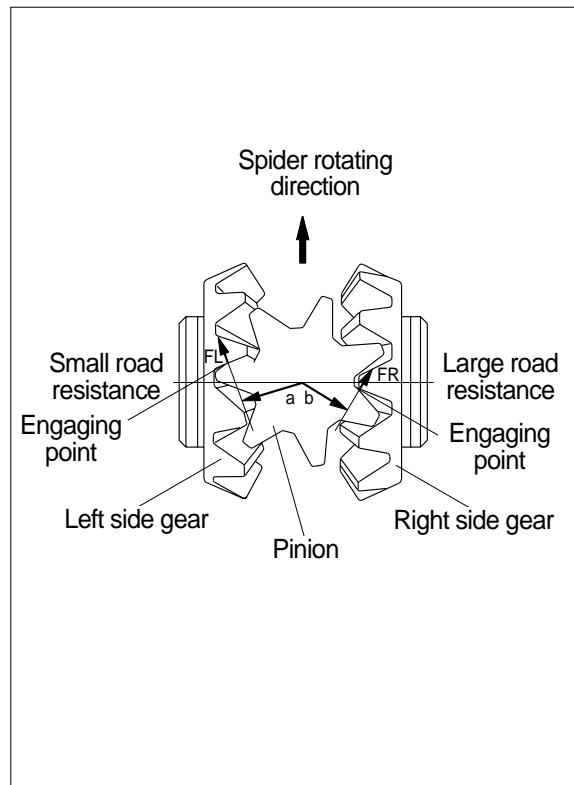

6) FINAL DRIVE(Front & rear)

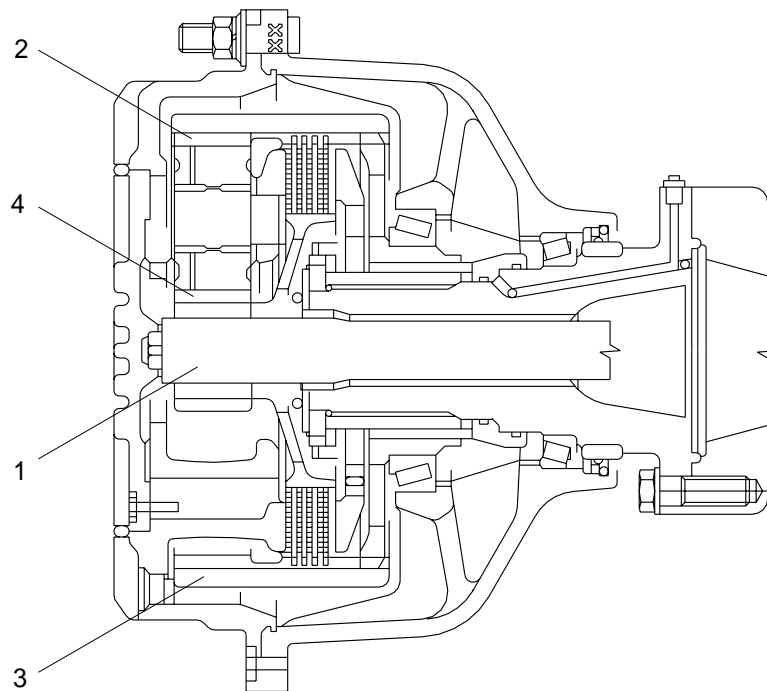

1 Axle shaft

3 Ring gear

4 Sun gear

2 Planetary gear

- (1) To gain a large drive force, the final drive uses a planetary gear system to reduce the speed and send drive force to the tires.
- (2) The power transmitted from the differential through axle shaft(1) to sun gear(4) is transmitted to planetary gear(2). The planetary gear rotates around the inside of a fixed ring gear(3) and in this way transmits rotation at a reduced speed to the planetary carrier. This power is then sent to the wheels which are installed to the planetary carriers.

6. TIRE AND WHEEL

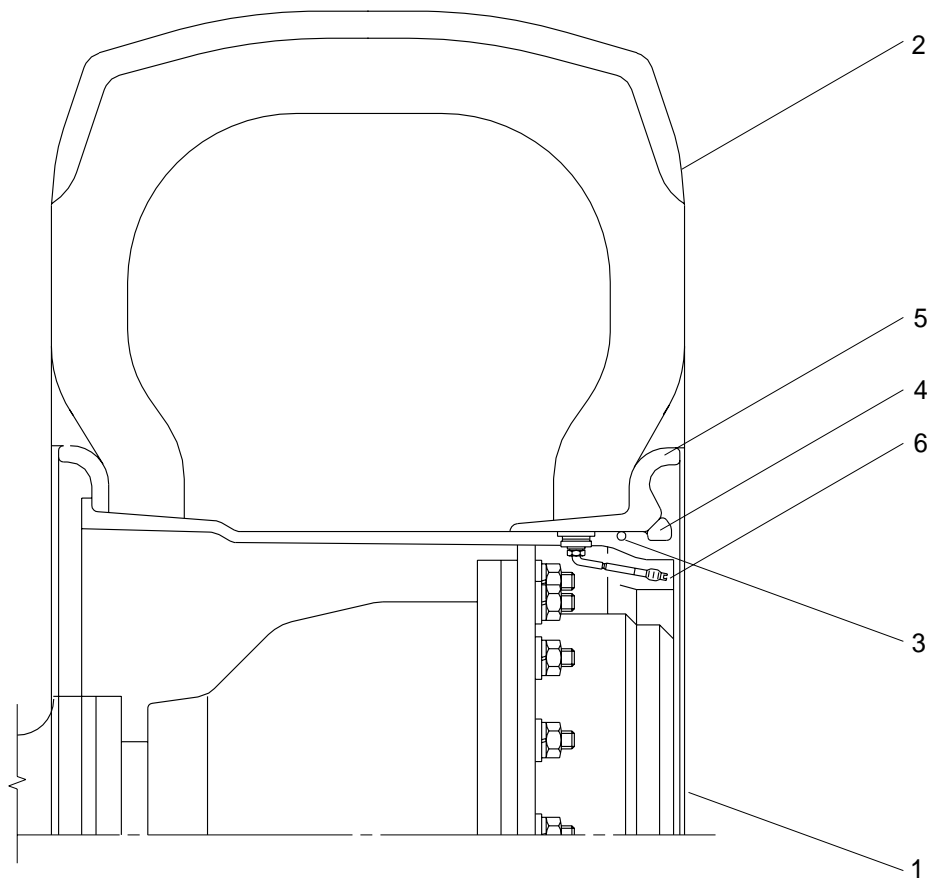

1 Wheel rim
2 Tire

3 O-ring
4 Lock ring

5 Side ring
6 Valve assembly

- 1) The tire acts to absorb the shock from the ground surface to the machine, and at the same time they must rotate in contact with the ground to gain the power which drives the machine.
- 2) Various types of tires are available to suit the purpose. Therefore it is very important to select the correct tires for the type of work and bucket capacity.