

GROUP 4 DISASSEMBLY AND ASSEMBLY

1. MAIN PUMP

1) STRUCTURE

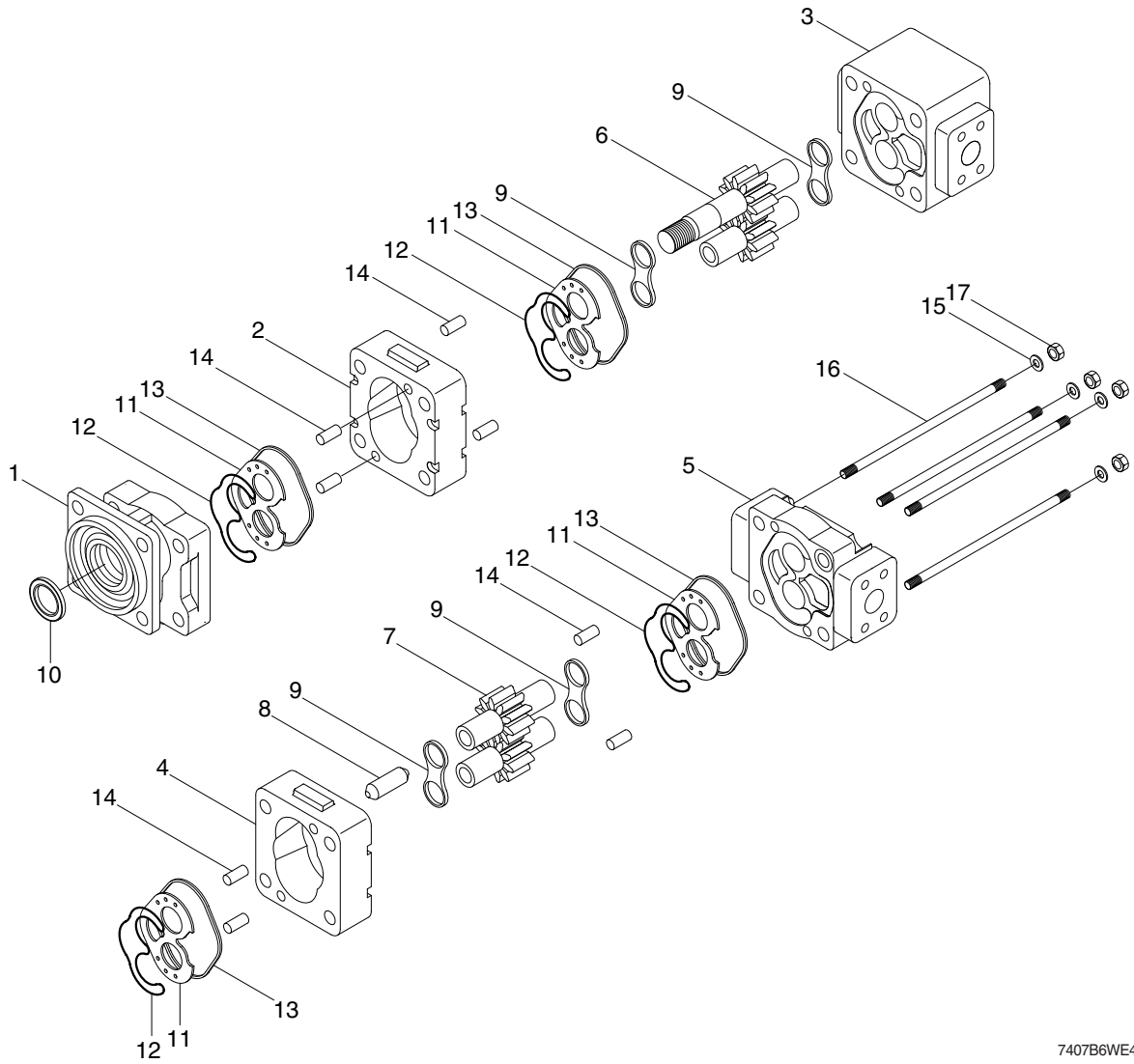

7407B6WE48

- | | | | | | |
|---|----------------|----|-----------------|----|-------------|
| 1 | Front cover | 7 | Driven gear set | 13 | Square seal |
| 2 | Housing | 8 | Connector shaft | 14 | Dowel pin |
| 3 | Carrier | 9 | Thrust plate | 15 | Washer |
| 4 | Housing | 10 | Lip seal | 16 | Stud bolt |
| 5 | Rear cover | 11 | Rubber seal | 17 | Hex nut |
| 6 | Drive gear set | 12 | Back up seal | | |

2) MANDATORY REPLACEMENT PARTS

Discard all seals including square seals, lip seals, rubber seals and back up seals. Fit new seals on reassembly. Thrust plates should also be replaced with new items from seal kit.

3) HANDLING/STORAGE

While disassembling pump, ensure no surfaces are scored or marked in any way. A rubber surfaced table will be beneficial. All components must be placed in a clean, dry and safe area.

Leakage will be created by scratches on components. If parts are to be left for any period ensure they are not exposed to dirt, dust and corrosion. Keep gears separate from each other in protective boxes.

4) INSPECTION OF PARTS

Wash all parts in a solvent and dry.

(1) Cover, housing and carrier

The pump must be replaced if the damage listed is present.

Feature	Damage
Surfaces	Corrosion, nicks or burrs (slight burrs can be removed using an India stone)
Machined sealing Interfaces	Scores, cracks or corrosion

(2) Gears

The pump must be replaced if the damage listed is present.

Feature	Damage
Surfaces	Corrosion, nicks or burrs (slight burrs can be removed using an India stone). Wear due to seal (s)
Journals	Pitting, wear, sufficient wear to change outside diameter
Tooth	Cracks or heavy scoring or chipped
Splines/keyways	Distortion or wear
End faces	Wear, cracks

(3) Bolts/studs

The pump should be replaced if the damage listed is present.

Feature	Damage
Surfaces	Corrosion, nicks or burrs (slight burrs can be removed using an India stone), cracks or scoring, distortion or damage to thread form

5) ASSEMBLY

(1) Prepare sub assembled parts (front and rear cover, carrier, housing, thrust plate).

※ Grease must be spreaded slightly on each seal.



(2) Put section sub assembly on the assembly table.

Assemble dowel pins.



(3) Assembly gear housing and thrust plate.

※ Check the contact status of square seal.



(4) Mount a jig on the shaft end to protect lip seal.

Assemble drive gear.



- (5) Assemble driven gear.
Spread hydraulic fluid around gear set.



- (6) Assemble thrust plate.
Rotate the shaft gear and check status of gear set.
Assemble dowel pins and connector shaft.



- (7) Assemble sub assy of carrier.
Inlet hole is located on the right side.
※ Outlet drill hole is located at the bottom of carrier. Sub assy of piggy back type carrier is the same.



- (8) Assemble gear housing and thrust plate.
※ Check the contact status of square seal.



- (9) Assemble drive gear set.
Spread hydraulic fluid around gear set.



- (10) Assemble thrust plate.
Rotate the shaft gear and check status of gear set.
Assemble dowel pins and connector shaft.



- (11) Assemble the rear cover.
Check the contact status of square seal.



- (12) Assemble stud bolt and washer.
※ Washer : smooth - convex side up
※ Keep bolts in dry condition after washing.



(13) Nuts are pre-assemble by hand.



(14) Use air impact to assemble nuts.
At this time, assemble nuts diagonally.



(15) Use torque wrench to assemble.
· Tightening torque : 15 kgf · m
(108 lbf · ft)



2. MAIN CONTROL VALVE

1) STRUCTURE

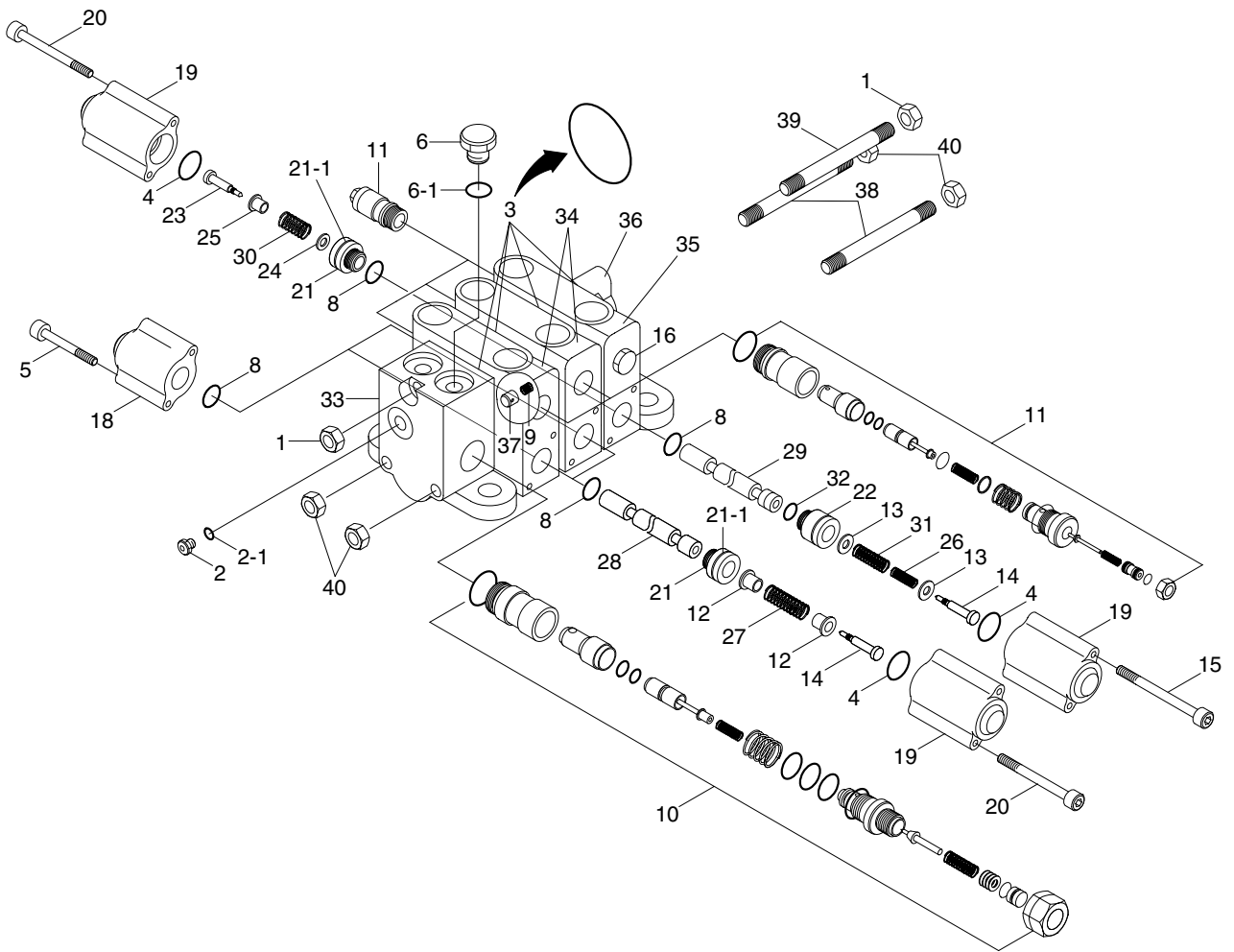

7407B6WE45

1	Nut	14	Screw	28	Spool
2	Plug	15	Screw	29	Spool
2-1	O-ring	16	Anti void assy	30	Spring
3	O-ring	18	Spool cap	31	Spring
4	O-ring	19	Spool cap	32	Back up ring
5	Cap screw	20	Cap screw	33	Inlet section assy
6	Plug	21	Spool retainer	34	Spool section assy
6-1	O-ring	21-1	Back up ring	35	Spool section assy
8	O-ring	22	Spool retainer	36	Outlet section assy
9	Spring	23	Screw	37	Poppet
10	Main relief valve	24	Washer	38	Tie rod
11	Port relief valve	25	Spacer	39	Tie rod
12	Spring seat	26	Spring	40	Nut
13	Washer	27	Spring		

2) ASSEMBLY AND DISASSEMBLY

(1) Lay out valve components on a clean, flat working surface. The inlet assembly will include an O-ring, and the spool section(s) include an O-ring, a load check poppet and a load check spring. Tools required for basic valve assembly include 3/4 and 11/16 open or box end wrenches and a torque wrench with thin wall sockets.

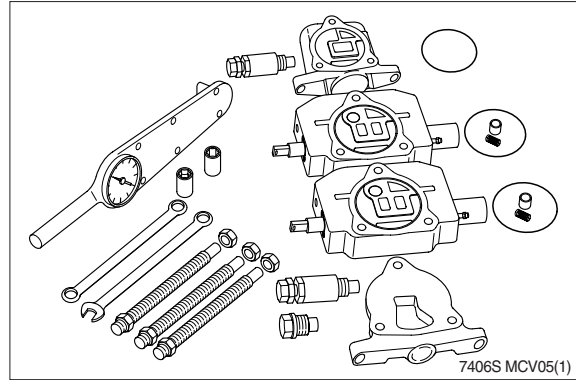

(2) Assemble tie rod nuts to one end of each tie rod with one or two threads showing. Insert tie rods through tie rod holes of inlet (large tie rod at top). Lay inlet on end with tie rods up, place O-ring into position.

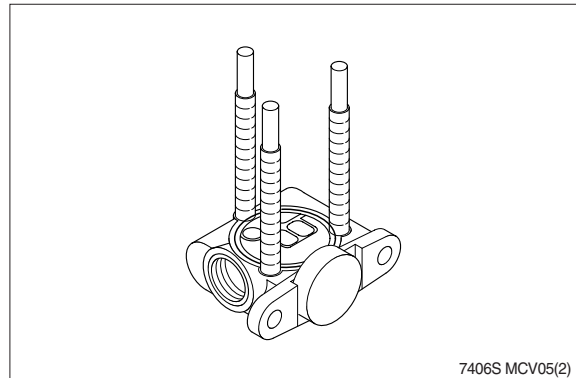

(3) Place first spool section (O-ring side up) on inlet section, position O-ring and insert load check poppet (nose down) and spring (behind poppet) into load check cavity as shown. Repeat this procedure for each spool section ; The load check springs are compressed by the following sections during assembly.

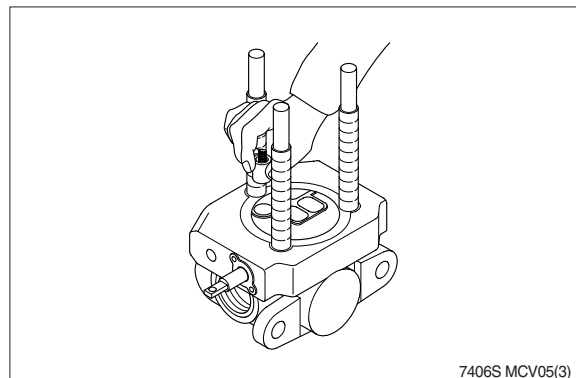

(4) Position end section on last spool section as shown and hand tighten tie rod nuts. The end section on picture is a "turn around" section without ports. Universal outlet/power beyond section and power beyond and closed center sections are also used as end sections. These end sections do not have O-ring grooves.

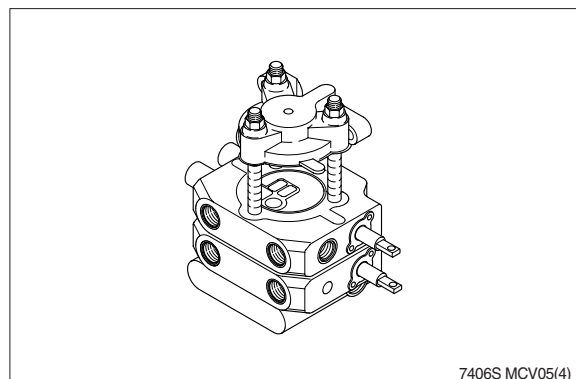

- (5) Position valve assembly with the mounting pads of the end sections on a flat surface. To obtain proper alignment of end sections relative to the spool sections apply downward pressure to the end sections ; Snug tie rod nuts to about 10 lbf · ft.
Final torque the two 11/16 nuts to 48 ± 5 lbf · ft ; Final torque the 3/4 nut to 74 ± 8 lbf · ft. Check for proper spool movement.

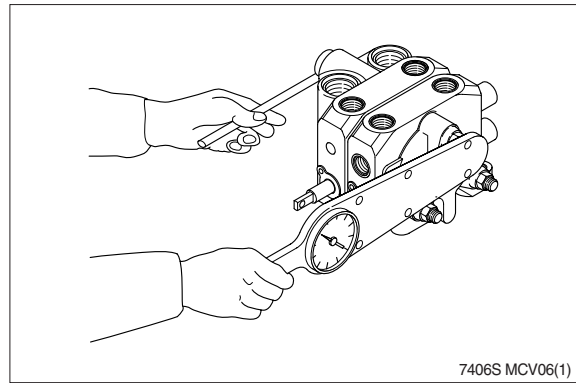

- (6) Install auxilliary valves and plugs and torque to proper specifications.
General assembly notes :
A. Lever assemblies can be installed on section before or after complete valve assembly.
B. The load check and spring may be ommitter from assembly in certain circuit conditions (i.e., motor spools).

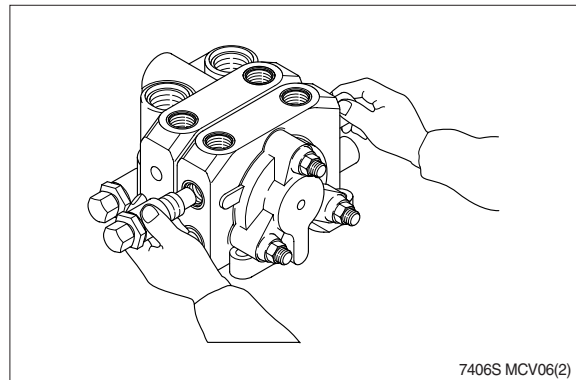

3. REMOTE CONTROL VALVE

1) STRUCTURE

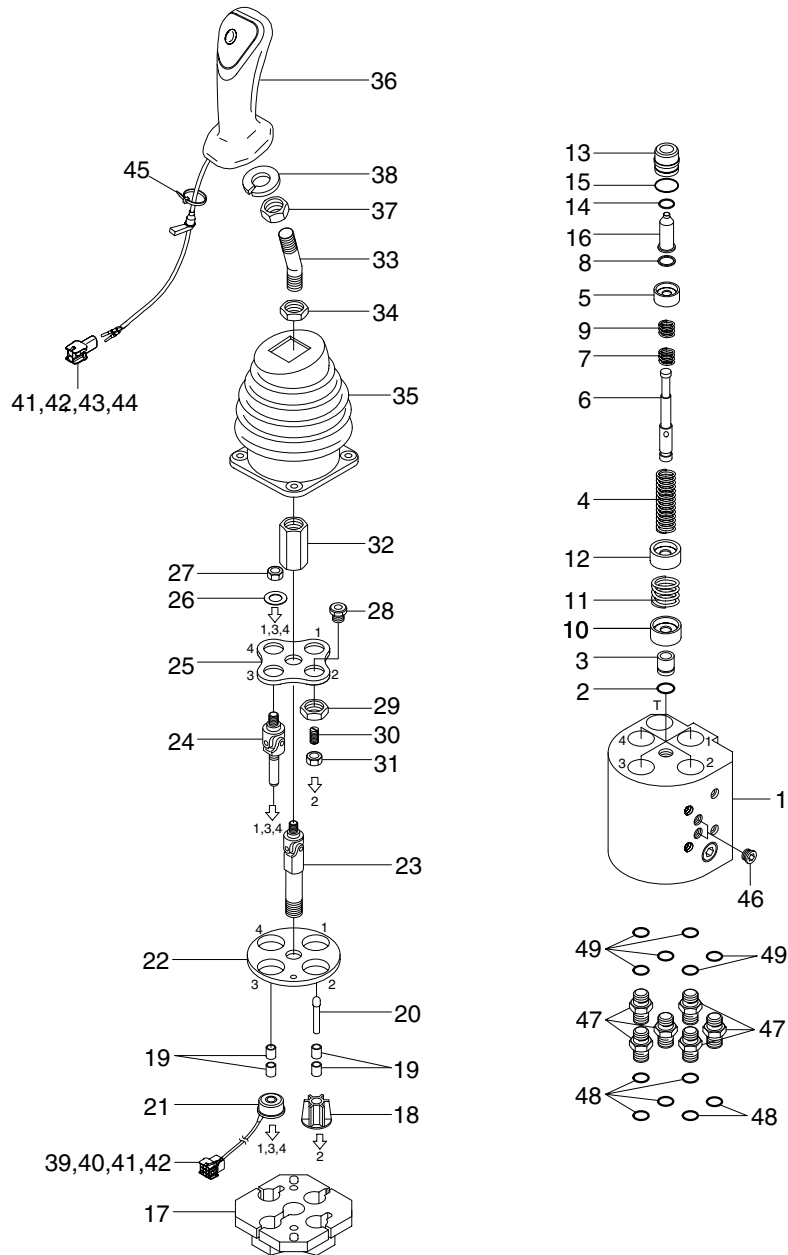

7407S6WE48

1	Body	14	Rod seal	27	Nut	40	Rear holder
2	O-ring	15	O-ring	28	Plug	41	Terminal
3	Plug	16	Push rod	29	Nut	42	Seal wire
4	Spring	17	Plate	30	Set screw	43	Housing
5	Spring seat	18	Rod stopper	31	Nut	44	Rear holder
6	Spool	19	Bushing	32	Nut	45	Clip band
7	Spring seat	20	Rod	33	Handle bar	46	Plug
8	Stopper	21	Magnet	34	Nut	47	Connector
9	Spring	22	Plate	35	Boot	48	O-ring
10	Spring seat	23	Joint assy	36	Handle assy	49	O-ring
11	Spring	24	Joint assy	37	Nut		
12	Spring seat	25	Plate	38	Spring washer		
13	Plug	26	Washer	39	Housing		

2) DISASSEMBLY

(1) Remove the boot (35) and loosen nut (34).

- Tool : spanner 19 mm



7607BRCV01



7607BRCV02

(2) Remove nut (32).



7607BRCV03

(3) Disassemble plate kit.

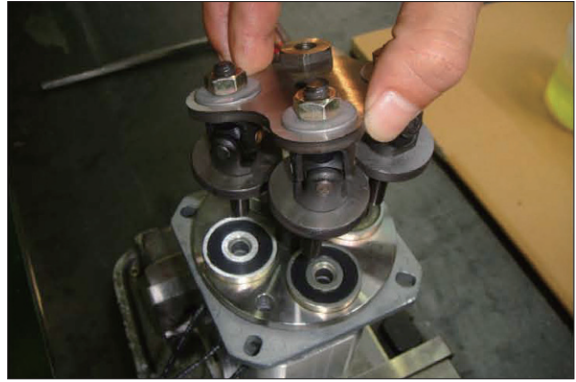

7607BRCV04

(4) Remove rod (20).



7607BRCV05

(5) Remove joint assembly (23).

· Tool : spanner 17 mm



7607BRCV06

(6) Disassemble plate (22).



7607BRCV07

(7) Disassemble magnet (21) and rod stopper (18).

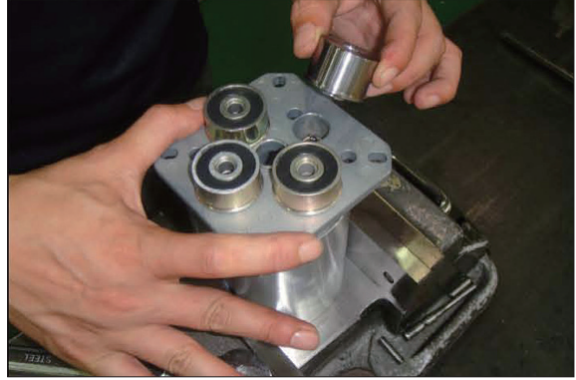

7607BRCV08

(8) Disassemble plate (17).

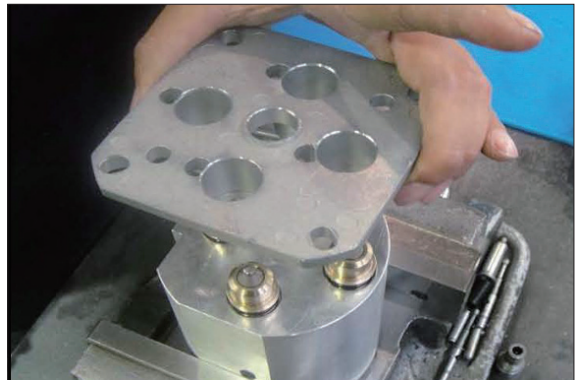

7607BRCV09

(9) Disassemble plug kit.

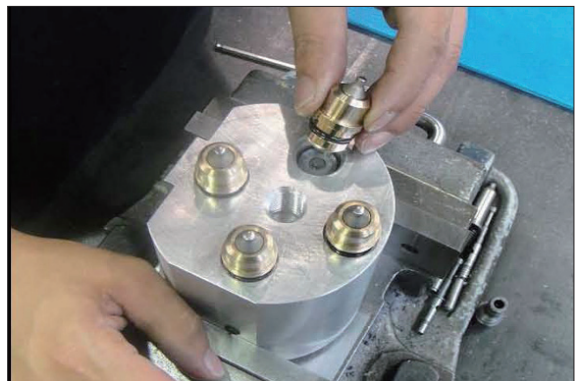

7607BRCV10

(10) Disassemble spring (4) and spool kit.

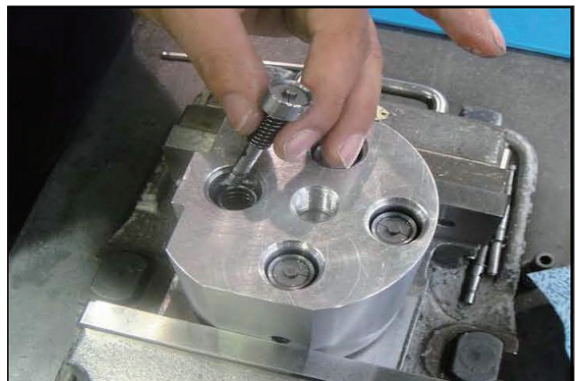

7607BRCV11

- (11) Disassemble plug (2).
- Tool : wrench 10 mm



7607BRCV12

3) ASSEMBLY

- (1) Coat oil on O-ring and mount plug (3) into body assembly (1).

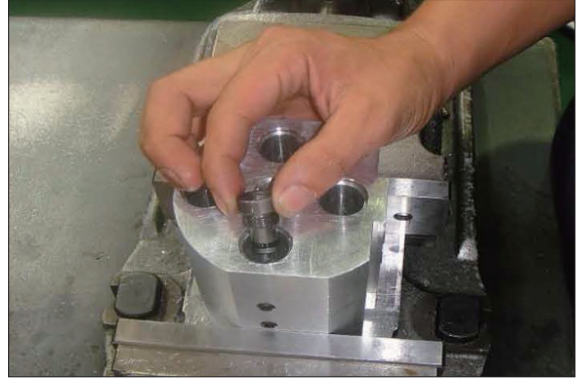

7607BRCV13

- (2) Tighten the plug (3).

- Tool : wrench 10 mm
- Tightening torque (M14) :
 $30 \pm 3 \text{ kgf} \cdot \text{m}$ ($217 \pm 21.7 \text{ lbf} \cdot \text{ft}$)



7607BRCV14

- (3) Assemble spring (4).



7607BRCV15

- (4) Assemble spool kit.

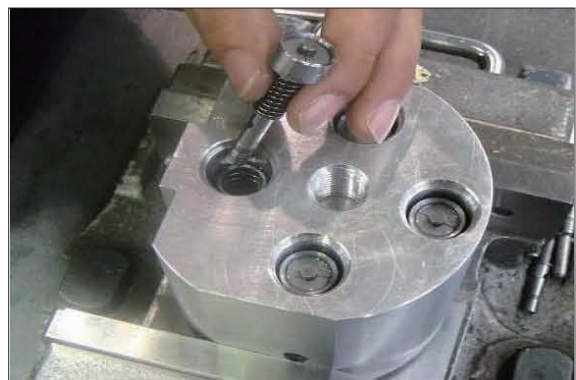

7607BRCV16

(5) Assemble plug kit.

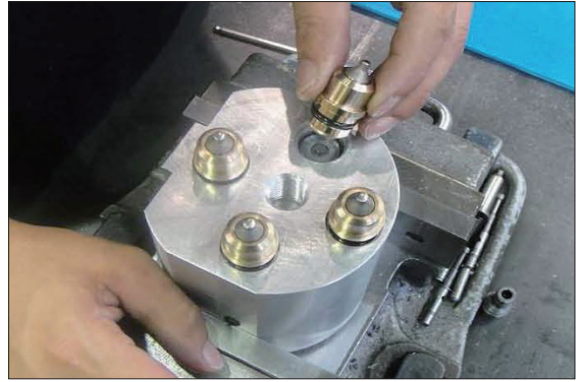

7607BRCV17

(6) Assemble plate (17).

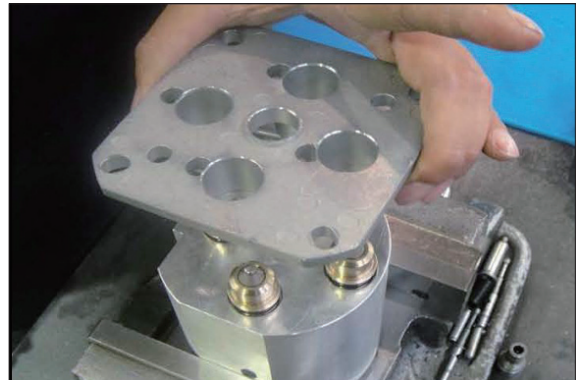

7607BRCV09

(7) Assemble magnet (21) at port 1, 3 and 4.
Assemble rod stopper (18) at port 2.

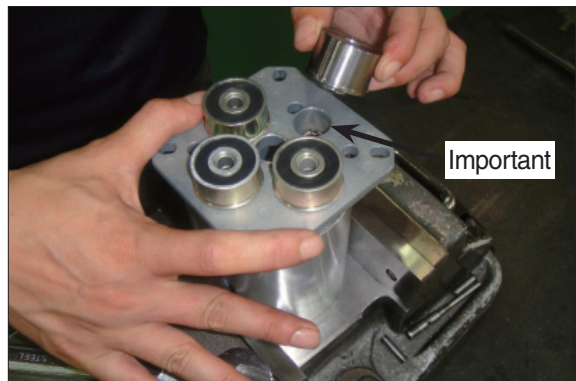

7607BRCV19

(8) Confirm port 2 on the bottom of the body.

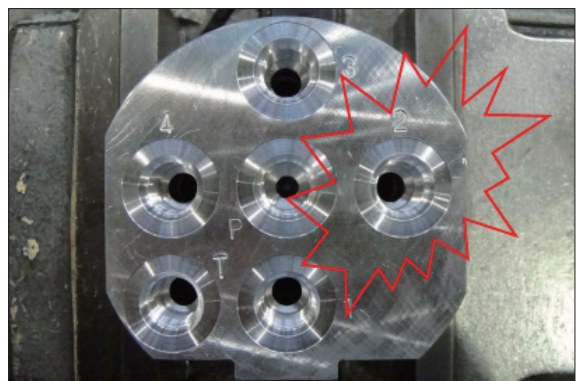

7607BRCV20

(9) Assemble plate (22).

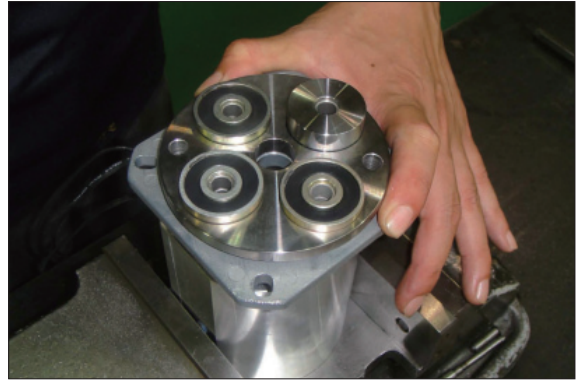

7607BRCV21

(10) Assemble joint assembly (23) and put grease on joint pin lightly.

- Tools : spanner 17 mm
- Tightening torque (M16) :
 $45 \pm 4.5 \text{ kgf} \cdot \text{m}$ ($325 \pm 32.5 \text{ lbf} \cdot \text{ft}$)



7607BRCV22



7607BRCV23

(11) Assemble rod (20).



7607BRCV24

(12) Assemble plate kit.

Put a bit of grease on rod (20) and Joint (24).



7607BRCV04

(13) Assemble nut (32).

- Tool : spanner 17 mm
- Tightening torque (M12) :
 $40 \pm 4 \text{ kgf} \cdot \text{m}$ ($289 \pm 28.9 \text{ lbf} \cdot \text{ft}$)



7607BRCV03



7607BRCV02

(14) Assemble nut (34).

- Tool : spanner 19 mm
- Tightening torque (M12) :
 $40 \pm 4 \text{ kgf} \cdot \text{m}$ ($28 \pm 28.9 \text{ lbf} \cdot \text{ft}$)



7607BRCV01

(15) Assemble the boot (35).



7607BRCV25