

Cap type (1/2, opt)

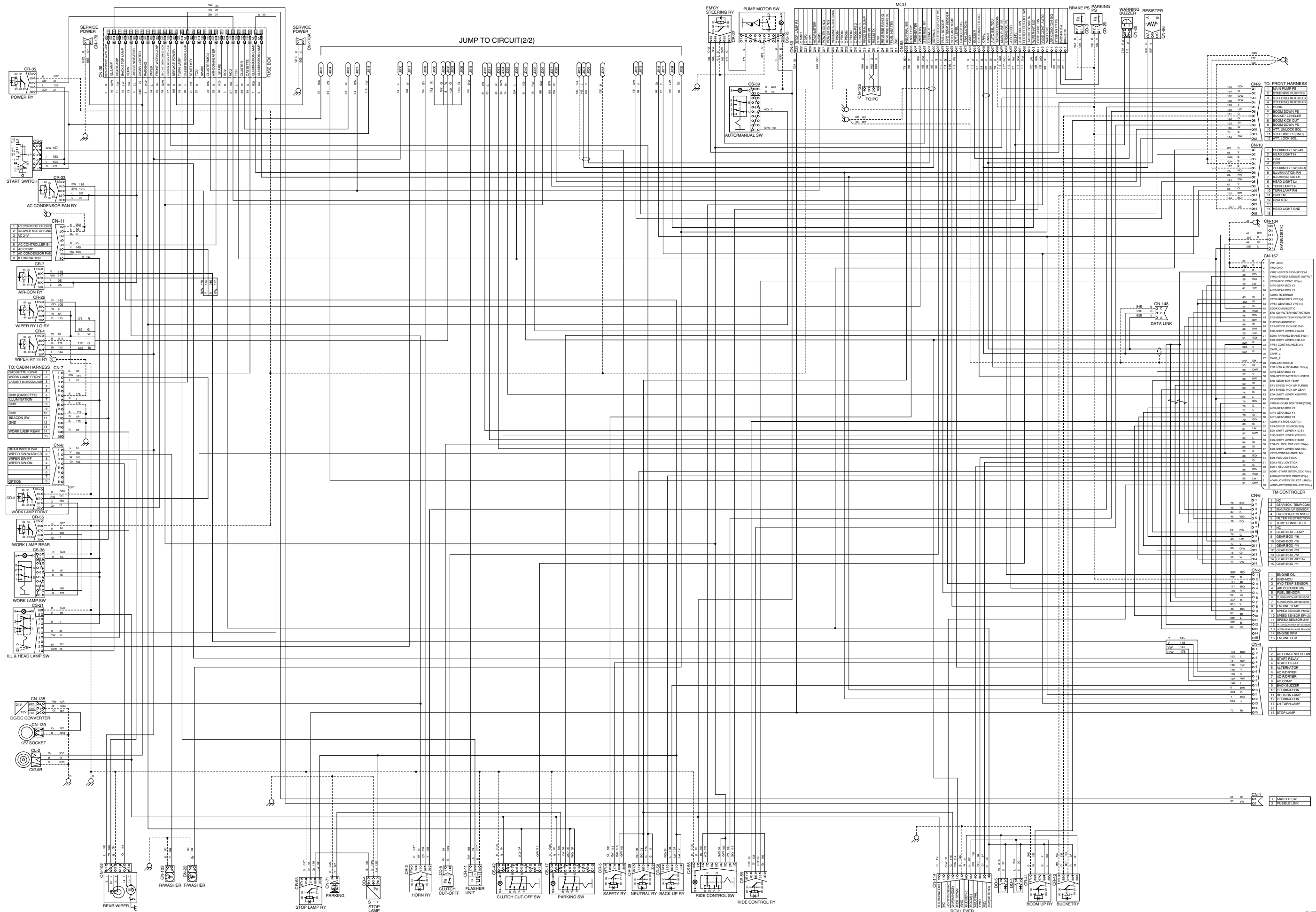



1. ILLUMINATION CIRCUIT

1) OPERATING FLOW

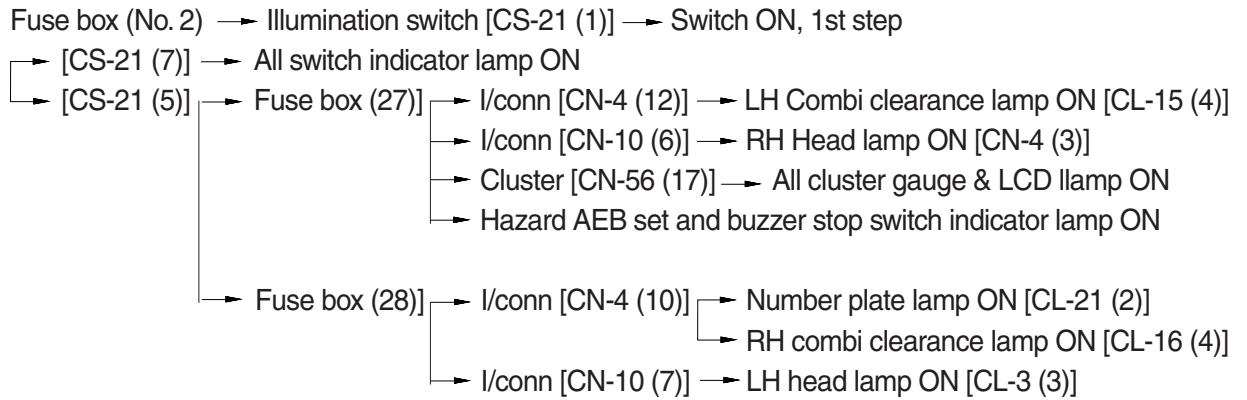

2) CHECK POINT

Engine	Key switch	Check point	Voltage
OFF	ON	① - GND (switch input) ② - GND (switch output) ③ - GND (to light) ④ - GND (to cluster)	20~25V

※ GND : Ground

ILLUMINATION CIRCUIT

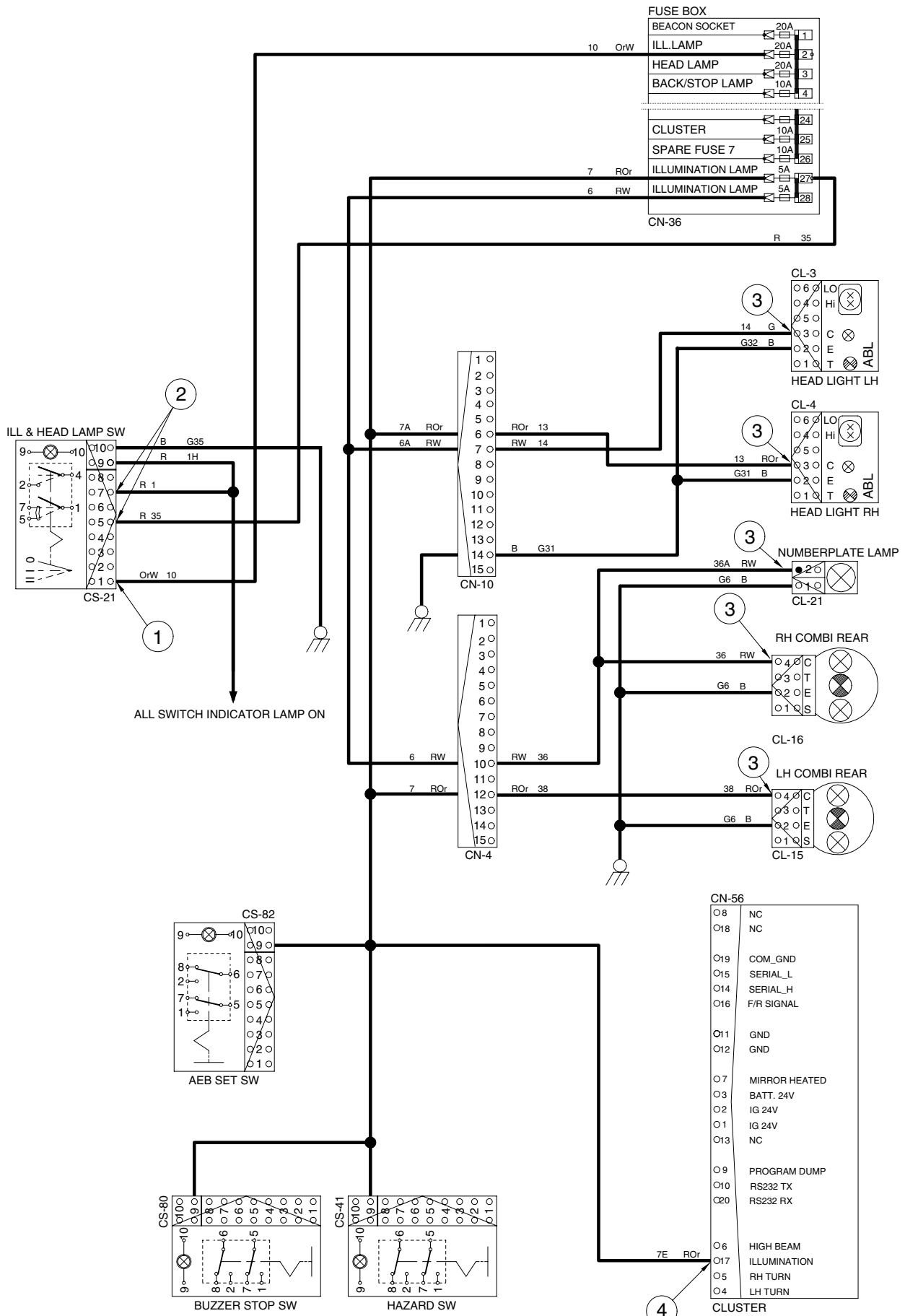

CN-56

08	NC
018	NC
019	COM_GND
015	SERIAL_L
014	SERIAL_H
016	F/R SIGNAL
011	GND
012	GND
07	MIRROR HEATED
03	BATT. 24V
02	IG 24V
01	IG 24V
013	NC
09	PROGRAM DUMP
010	RS232 TX
020	RS232 RX
06	HIGH BEAM ILLUMINATION
017	RH TURN
05	LH TURN
04	CLUSTER

7607S7EL03

2. HEAD LIGHT CIRCUIT

1) OPERATING FLOW

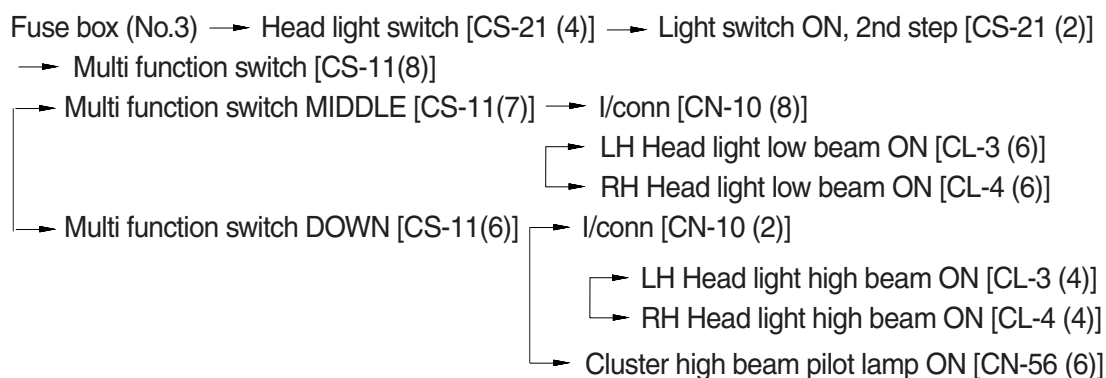

2) CHECK POINT

Engine	Key switch	Check point	Voltage
OFF	ON	① - GND (switch input) ② - GND (switch output) ③ - GND (multi function input) ④ - GND (multi function output) ⑤ - GND (multi function output) ⑥ - GND (low beam) ⑦ - GND (high beam) ⑧ - GND (passing B ⁺)	20~25V

※ GND : Ground

HEAD LIGHT CIRCUIT

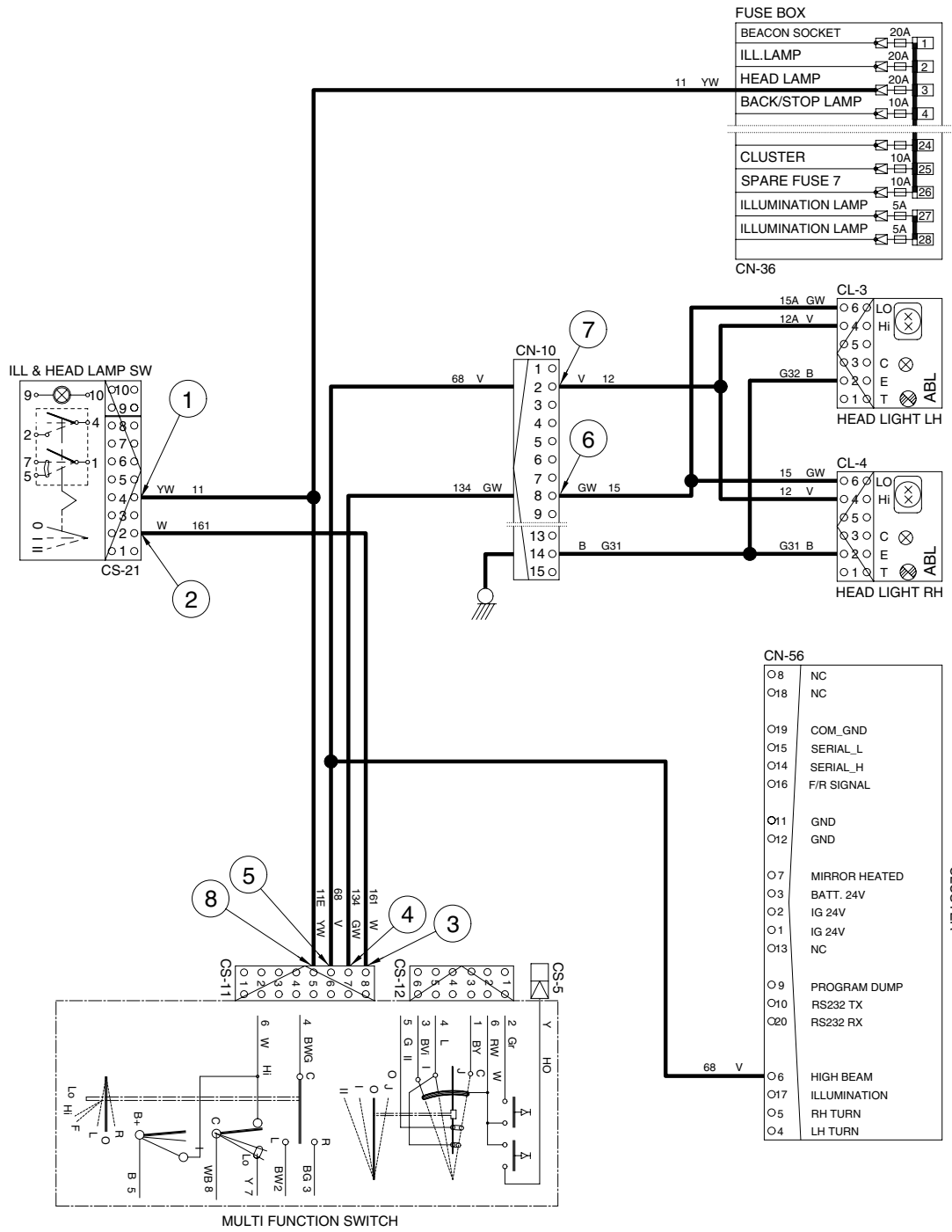

7607B7EL04

3. WORK LIGHT CIRCUIT

1) OPERATING FLOW

※ Illumination switch : ON position

(1) Work lamp switch ON

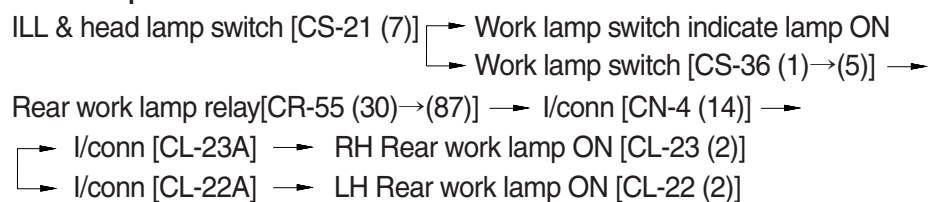

2) CHECK POINT

Engine	Key switch	Check point	Voltage
OFF	ON	① - GND (work lamp power input) ② - GND (work lamp power output) ③ - GND (rear work lamp)	20~25V

※ GND : Ground

WORK LIGHT CIRCUIT

• Canopy type

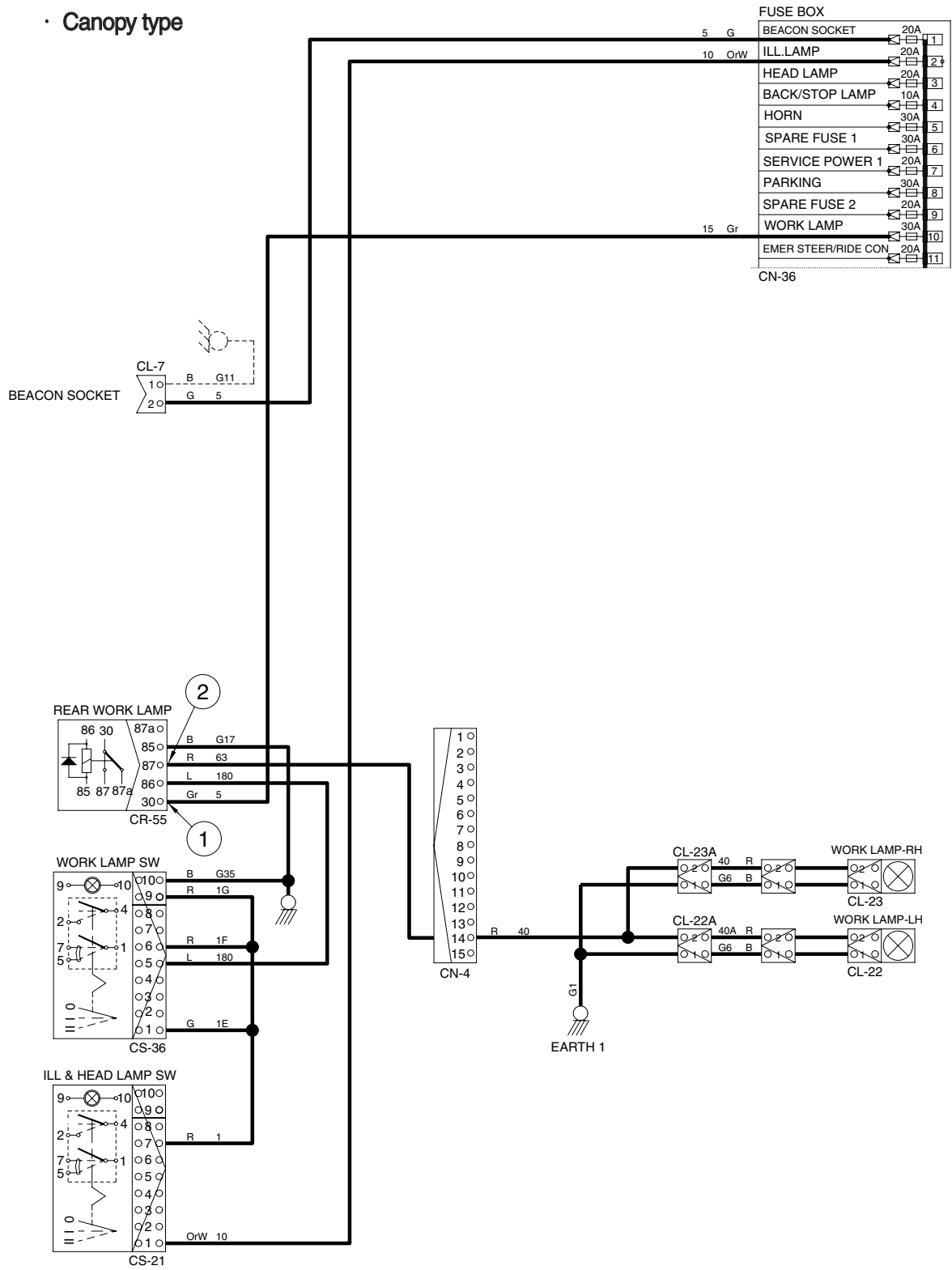

WORK LIGHT CIRCUIT

· Cab type (opt)

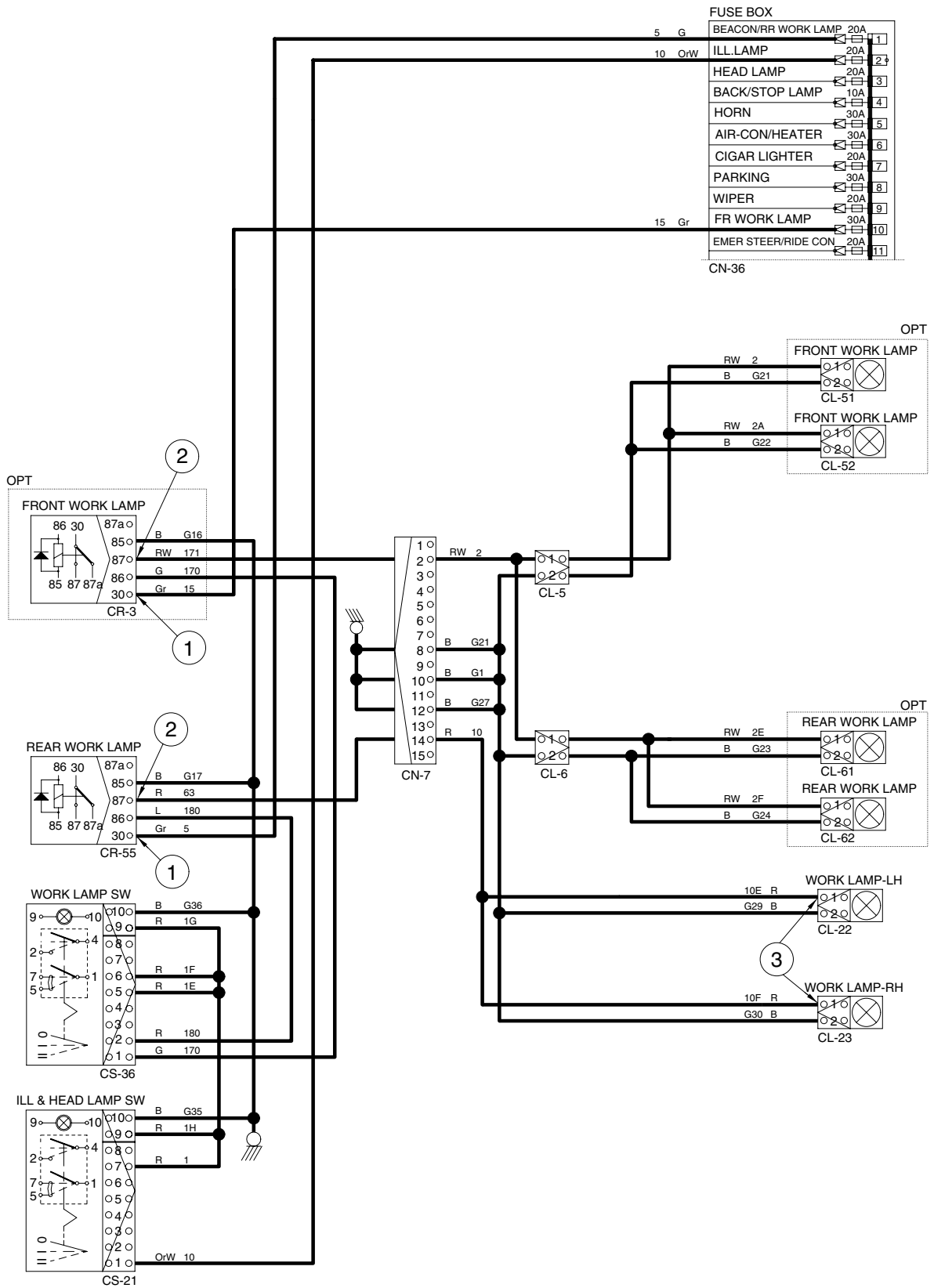

4. STARTING CIRCUIT

1) OPERATING FLOW

Battery(+) terminal → Fusible link [CN-60 (1)]
 → I/conn [CN-1 (1)] → Fuse box (No.15) → Start switch [CS-2(1)]
 → Power relay [CR-35(30)]

※ The gear selector lever is neutral position. It is necessary condition before the starting.
 The gear selector has an output signal which is activated whenever the shift lever is in the neutral position. This signal can be used to control a relay and prevent engine from starting whenever the shift lever is not in the neutral position.

(1) When start key switch is in ON position

Start switch ON → Start switch [CS-2(2)] → I/conn [CN-4(3)]
 → I/conn [CN-13(11)] → Engine stop solenoid [CN-79(A)]
 → Battery relay [CR-1]
 → Battery relay operating(All power is supplied with the electric component)
 → Start switch [CS-2 (3)] → Power relay [CR-35(30)→(87)]
 → Fuse box (No.23) → MCU [CN-58(12)]

(2) When start key switch is in START position

Start switch START [CS-2 (5)] → Start safety relay [CR-5 (30)→(87)] → I/conn [CN-4 (4)]
 → I/conn[CN-13 (7)] → Start relay [CR-23] → Starter (terminal B⁺ and M connector of start motor)

2) CHECK POINT

Engine	Key switch	Check point	Voltage
Running	ON	① - GND (battery B ⁺) ② - GND (fusible link) ③ - GND (start key B terminal) ④ - GND (start key BR terminal) ⑤ - GND (i/conn CN-4 (3)) ⑥ - GND (start key ST terminal) ⑦ - GND (start safety relay output) ⑧ - GND (start key ACC terminal)	20~25 V

※ GND : Ground

※ MCU : Machine control unit

5. CHARGING CIRCUIT

When the starter is activated and the engine is started, the operator releases the key switch to the ON position.

Charging current generated by operating alternator flows into the battery through the battery relay (CR-1).

The current also flows from alternator to each electrical component and controller through the fuse box.

1) OPERATING FLOW

(1) Warning flow

Alternator [CN-74 (L)] → I/conn [CN-13 (8)] → I/conn [CN-4 (5)] → MCU [CN-58 (25)]
 → Cluster charge warning lamp ON

(2) Charging flow

Alternator → Starter [CN-45 (B⁺)] → Battery relay [CR-1]
 ↳ Battery(+) terminal → Charging
 ↳ Fusible link [CN-60 (1)] → I/conn [CN-1 (1)] → Fuse box

2) CHECK POINT

Engine	Key switch	Check point	Voltage
OFF	ON	① - GND (battery) ② - GND (battery relay) ③ - GND (alternator B ⁺) ④ - GND (alternator D ⁺) ⑤ - GND (MCU) ⑥ - GND (fuse box)	20~28V

※ GND : Ground

※ MCU : Machine control unit

CHARGING CIRCUIT

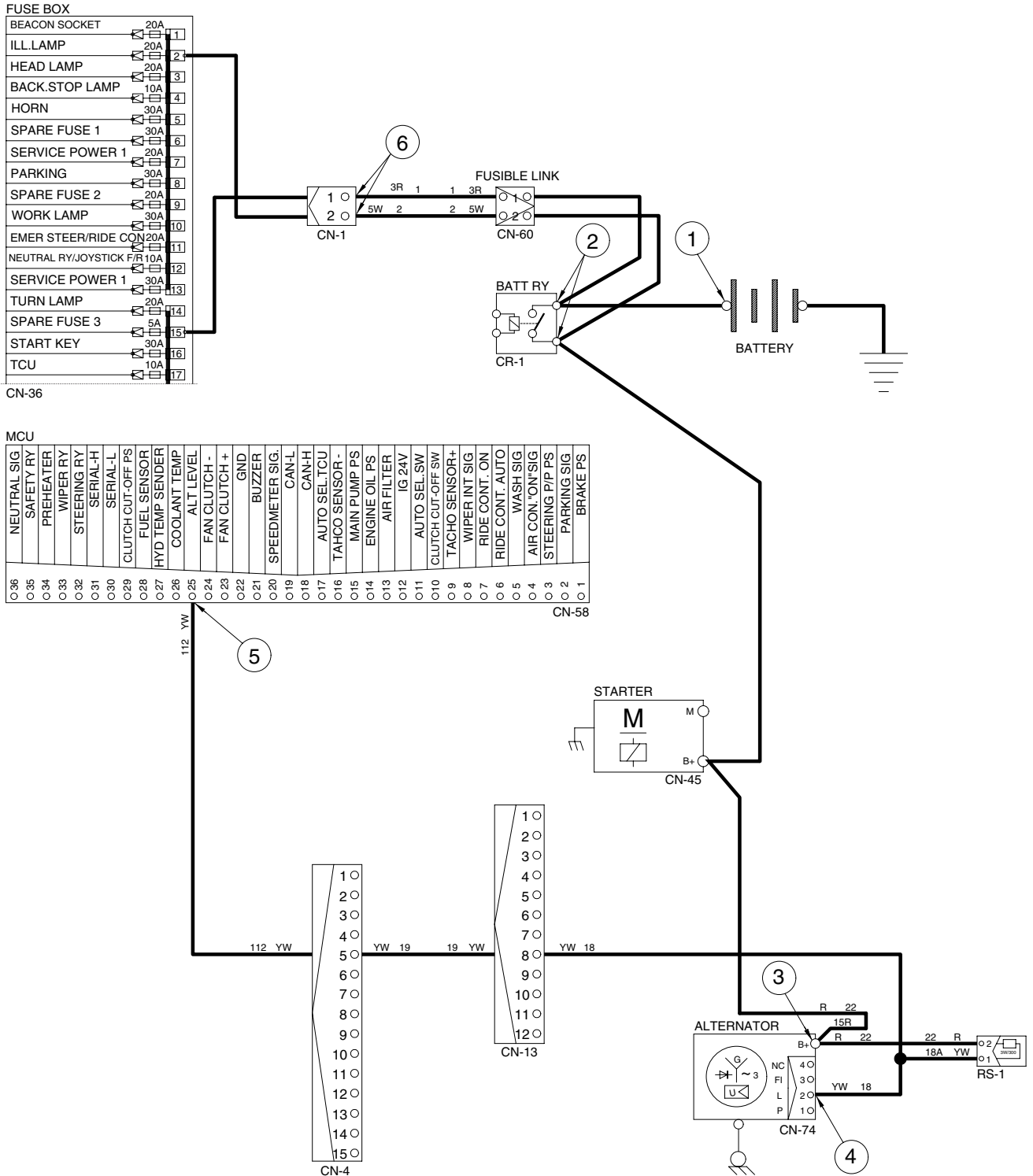

7407SEL07

6. ELECTRIC PARKING, DECLUTCH CIRCUIT

1) OPERATING FLOW

(1) Parking OFF

Fuse box (No.8) → Parking switch OFF → [CS-17 (6)→(8)] → Parking solenoid ON (activated)
 → Parking brake released (by hydraulic pressure)
 → [CS-17 (5)→(7)] → T/M control unit [CN-157 (21)]

(2) Parking ON

Fuse box (No.8) → Parking switch ON → Parking solenoid [CN-71] OFF
 → Parking brake applied [By spring force]

(3) Declutch ON

Fuse box (No.8) → Clutch cut-off switch ON → Clutch cut-off switch ON [CS-42 (5)→(1)]
 → MCU [CN-58 (10)→(29)] → if service brake applied → Service brake pressure switch
 ON [CD-5] → T/M control unit [CN-157 (66)] → Declutch

2) CHECK POINT

Engine	Key switch	Check point	Voltage
Running	ON	① - GND (parking switch input) ② - GND (parking switch output) ③ - GND (parking switch input) ④ - GND (parking switch output) ⑤ - GND (parking solenoid) ⑥ - GND (clutch cut-off pressure switch) ⑦ - GND (clutch cut-off switch input) ⑧ - GND (clutch cut-off switch output)	20~25V

※ GND : Ground

ELECTRIC PARKING, DECLUTCH CIRCUIT

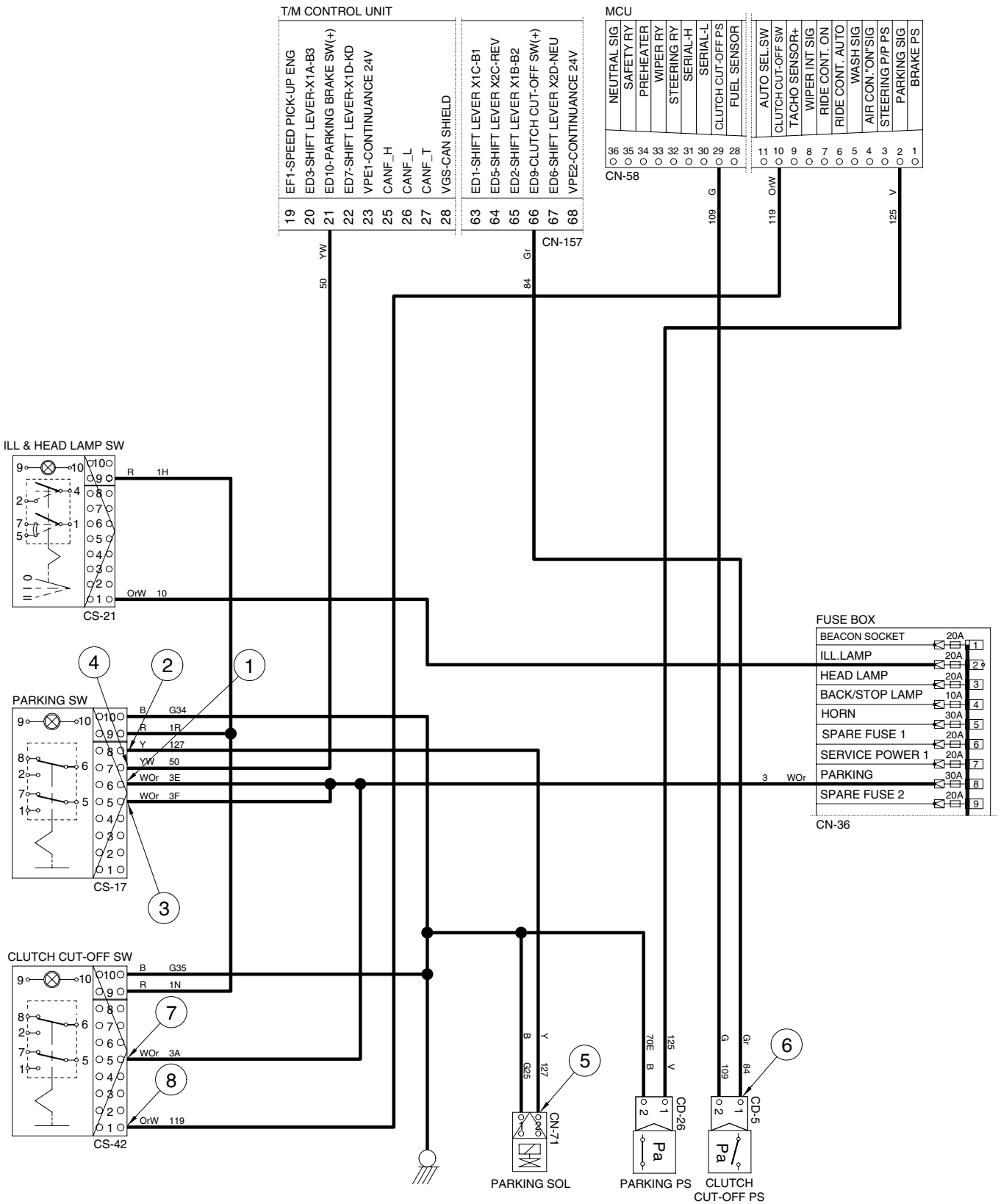

7407B7EL08

7. WIPER AND WASHER CIRCUIT (Cab type)

1) OPERATING FLOW

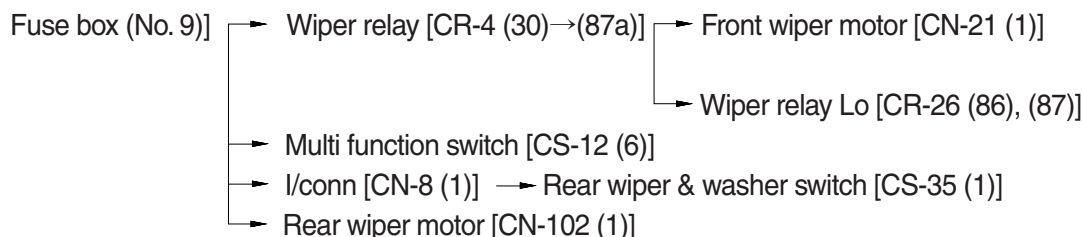

(1) Front washer switch ON

- ① Washer switch ON [CS-12(6)→(2)]
 - Washer operating
 - MCU [CN-58 (5)→(33)] → Front wiper relay Lo [CR-26 (87)→(30)] → Front wiper motor [CN-21 (5)] → Wiper motor operating (low)

(2) Front wiper switch ON

- ① INT position
 - Wiper switch ON [CS-12 (6)→(1)] → MCU [CN-58 (8)→(33)] → Wiper relay Lo [CR-26 (87)→(30)] → Front wiper motor [CN-21(5)] → Front wiper motor intermittently operating
- ② Lo position
 - Wiper switch ON [CS-12 (6)→(4)] → Wiper relay Lo [CR-26 (87a)→(30)] → Front wiper motor [CN-21 (5)] → Front wiper motor operating (low)
- ③ Hi position
 - Wiper switch ON [CS-12 (6)→(3)] → Wiper relay Hi [CR-4(30)→(87)] → Front wiper motor [CN-21(4)] → Front wiper motor operating (high)

(3) Auto-parking (when switch OFF)

- Switch OFF → Fuse box (No. 9) → Wiper relay Hi [CR-4 (30)→(87a)] → Front wiper motor [CN-21 (1)→(2)] → Multi function switch [CS-12 (5)→(4)] → Wiper relay Lo [CR-26 (87a)→(30)] → Front wiper motor [CN-21 (5)] → Wiper motor stop

(4) Rear wiper and washer switch

- ① Wiper switch ON (1st step)
 - Wiper switch ON [CS-35 (1)→(6)] → I/conn [CN-8 (4)] → Rear wiper motor [CN-102(5)] → Rear wiper motor operating
- ② Washer switch ON (2nd step)
 - Washer switch ON [CS-35 (1)→(3)] → I/conn [CN-8 (2)] → Rear washer tank [CN-103(2)] → Washer operating

2) CHECK POINT

Condition	Check point	
Engine : Stop	① - GND (front wiper switch power input)	⑥ - GND (wiper relay power input)
Key switch : ON	② - GND (rear wiper switch power input)	⑦ - GND (front washer power output)
Voltage : 20~25V	③ - GND (wiper relay power input)	⑧ - GND (rear washer power output)
	④ - GND (front wiper motor Lo power input)	⑨ - GND (front wiper motor power output)
	⑤ - GND (front wiper motor High power input)	⑩ - GND (rear wiper motor power output)

※ GND : Ground

WIPER AND WASHER CIRCUIT (cab type)

