

SECTION 3 POWER TRAIN SYSTEM

Group 1	Structure and Function	3-1
Group 2	Operational Checks and Troubleshooting	3-64
Group 3	Test and Adjustments	3-75
Group 4	Disassembly and Assembly	3-77

SECTION 3 POWER TRAIN SYSTEM

GROUP 1 STRUCTURE AND FUNCTION

1. POWER TRAIN COMPONENT OVERVIEW

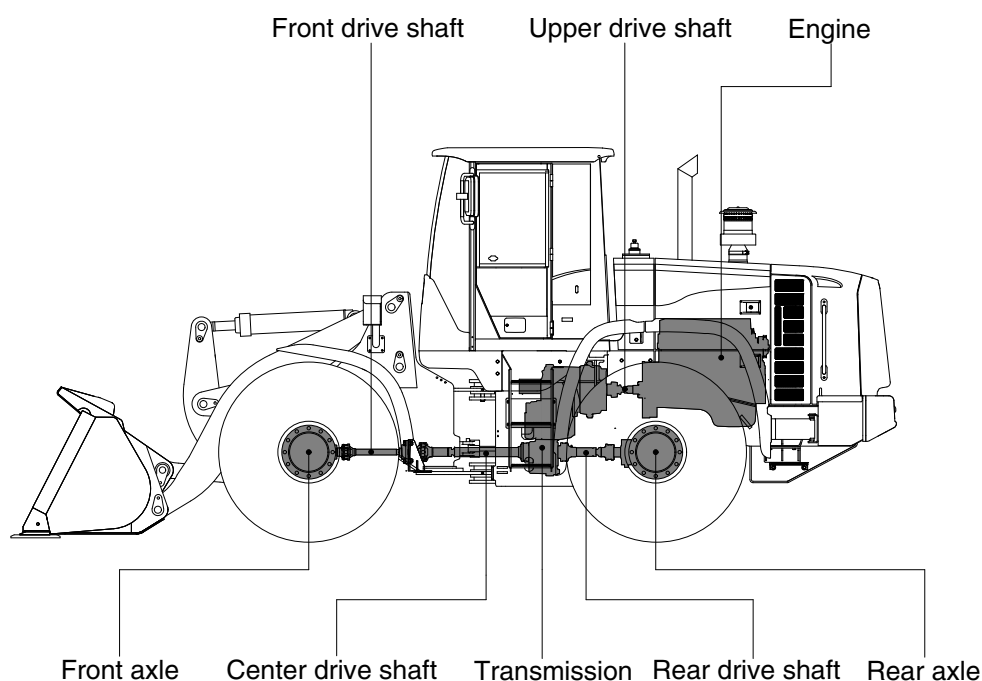

7309A3PT01

The power train consists of the following components:

- Transmission
- Front, center and rear drive shafts
- Front and rear axles

Engine power is transmitted to the transmission through the torque converter.

The transmission is a hydraulically engaged four speed forward, three speed reverse countershaft type power shift transmission. A calliper-disc type parking brake is located on the transmission.

The transmission outputs through universal joints to three drive shaft assemblies. The front drive shaft is a telescoping shaft which drives the front axle. The front axle is mounted directly to the loader frame. The front axle is equipped with conventional differential as standard (option : Limited slip differential). The rear axle is equipped with conventional differential as standard (option : Limited slip differential). The rear axle is mounted on an oscillating pivot.

The power transmitted to front axle and rear axle is reduced by the pinion gear and ring gear of differential. It then passes from the differential to the sun gear shaft (axle shaft) of final drive.

The power of the sun gear is reduced by a planetary mechanism and is transmitted through the planetary hub to the wheel.

HYDRAULIC CIRCUIT

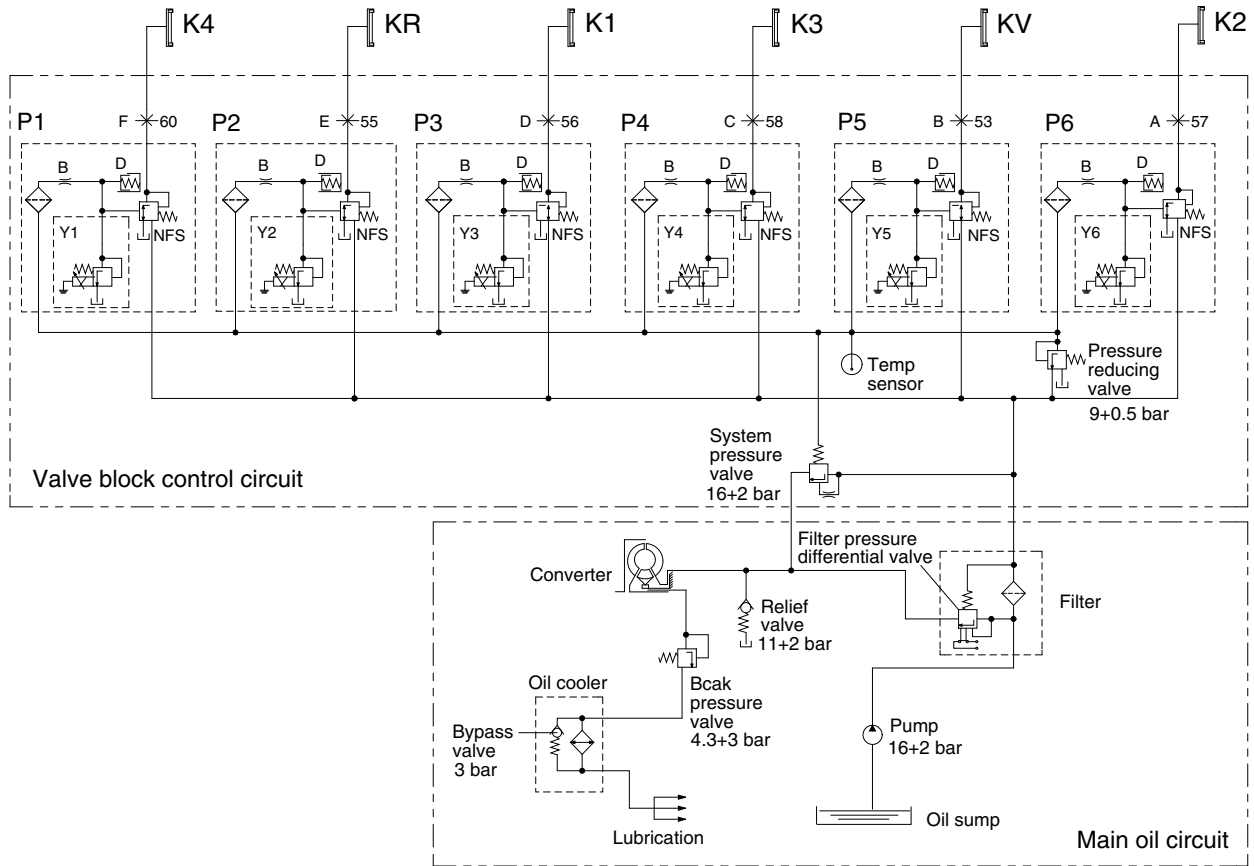

7607APT18

- | | | | |
|-----|------------------------------|-------|------------------------------|
| NFS | Follow-on slide | P3 | Proportional valve clutch K1 |
| D | Vibration damper | P4 | Proportional valve clutch K3 |
| B | Orifice | P5 | Proportional valve clutch KV |
| P1 | Proportional valve clutch K4 | P6 | Proportional valve clutch K2 |
| P2 | Proportional valve clutch KR | Y1~Y6 | Pressure regulator |

Speed	Forward				Reverse			Neutral	Engaged clutch	Positions on the valve block	Current No. of the measuring points
	1	2	3	4	1	2	3				
Y1				X					K4	F	60
Y2					X	X	X		KR	E	55
Y3	X				X				K1	D	56
Y4			X	X					K3	C	58
Y5	X	X	X						KV	B	53
Y6		X					X		K2	A	57
Engaged clutch	K1,KV	KV,K2	K3,KV	K4,K3	KR,K1	KR,K2	KR, K3		-	-	-

X : Pressure regulator under voltage

2. TORQUE CONVERTER

1) FUNCTION

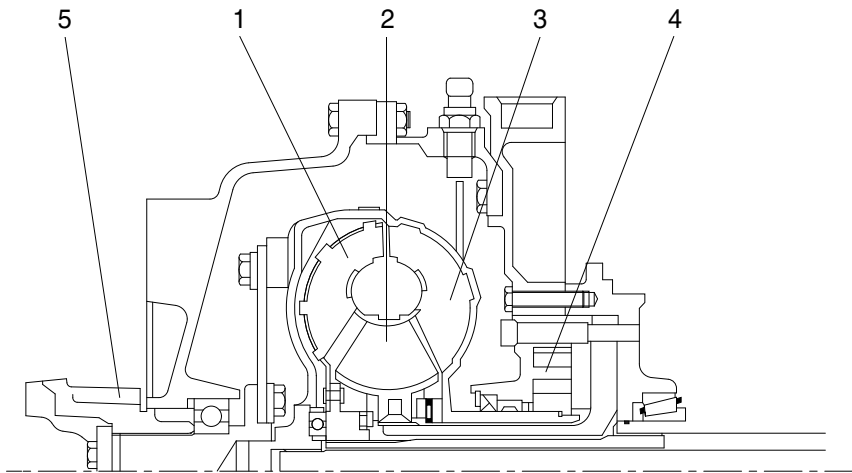

73033TM00

- | | | | | | |
|---|---------|---|-------------------|---|--------------|
| 1 | Turbine | 3 | Pump | 5 | Input flange |
| 2 | Stator | 4 | Transmission pump | | |

The converter is working according to the Trilok-system, i.e. it assumes at high turbine speed the characteristics, and with it the favorable efficiency of a fluid clutch.

The converter is designed according to the engine power so that the most favorable operating conditions are obtained for each installation case.

The Torque converter is composed of 3 main components :
Pump wheel - turbine wheel - stator (reaction member)

These 3 impeller wheels are arranged in such a ring-shape system that the fluid is streaming through the circuit components in the indicated order.

Pressure oil from the transmission pump is constantly streaming through the converter. In this way, the converter can fulfill its task to multiply the torque of the engine and at the same time, the heat created in the converter is dissipated via the escaping oil.

The oil which is streaming out of the pump wheel, enters the turbine wheel and is there inversed in the direction of flow.

According to the rate of reversion, the turbine wheel and with it also the output shaft is receiving a more or less high reaction torque. The stator (reaction member), following the turbine, has the task to reverse the oil streaming out of the turbine once more and to deliver it under the suitable discharge direction to the pump wheel.

Due to the reversion, the stator receiving a reaction torque.

The relation turbine torque/pump torque is called torque multiplication. This is the higher, the greater the speed difference of pump wheel and turbine wheel will be.

Therefore, the maximum torque multiplication is created at stationary turbine wheel.

With increasing output speed, the torque multiplication is decreasing. The adaption of the output speed to a certain required output torque will be infinitely variable and automatically achieved by the torque converter.

When the turbine speed is reaching about 80% of the pump speed, the torque multiplication becomes 1.0 i.e. the turbine torque becomes equal to that of the pump torque.
 From this point on, the converter is working similar to a fluid clutch.

A stator freewheel serves to improve the efficiency in the upper driving range, in the torque multiplication range it is backing-up the torque upon the housing, and is released in the clutch range. In this way, the stator can rotate freely.

Function of a hydrodynamic torque converter (schematic view)

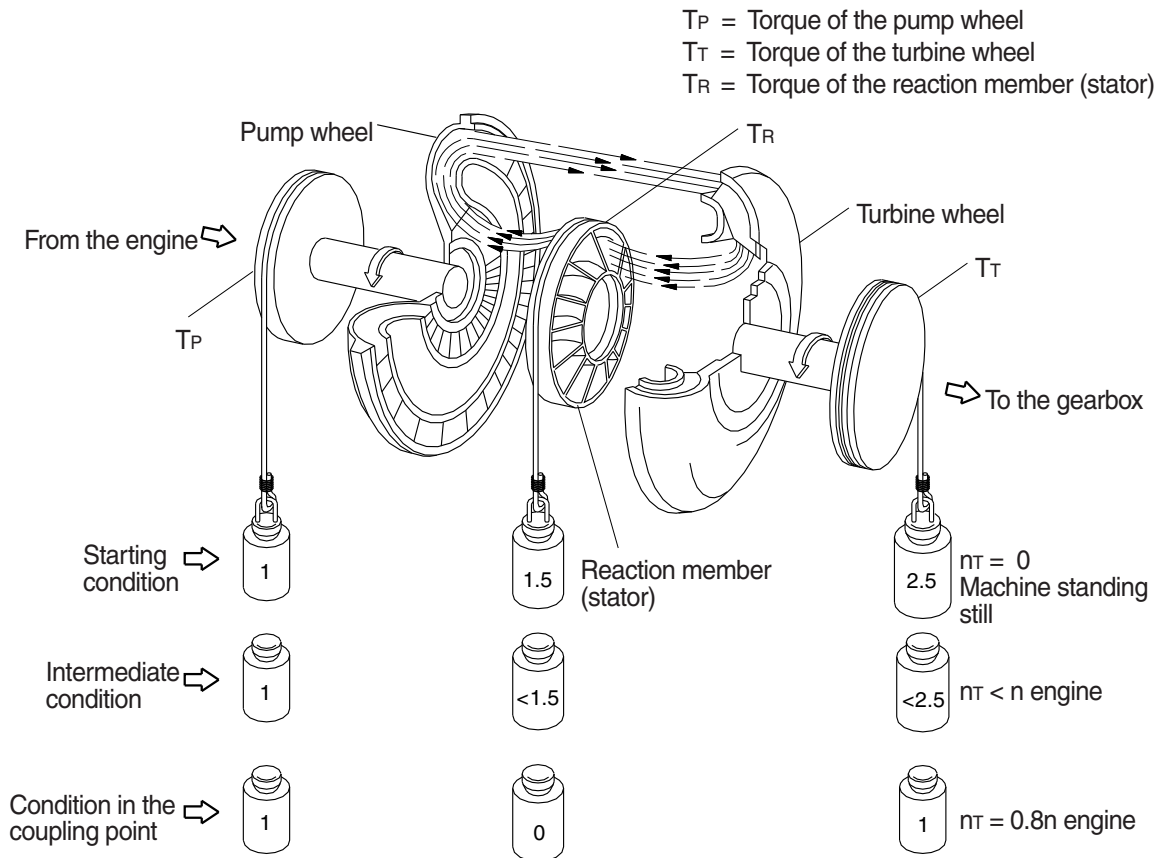

7577APT100

3. TRANSMISSION

1) LAYOUT

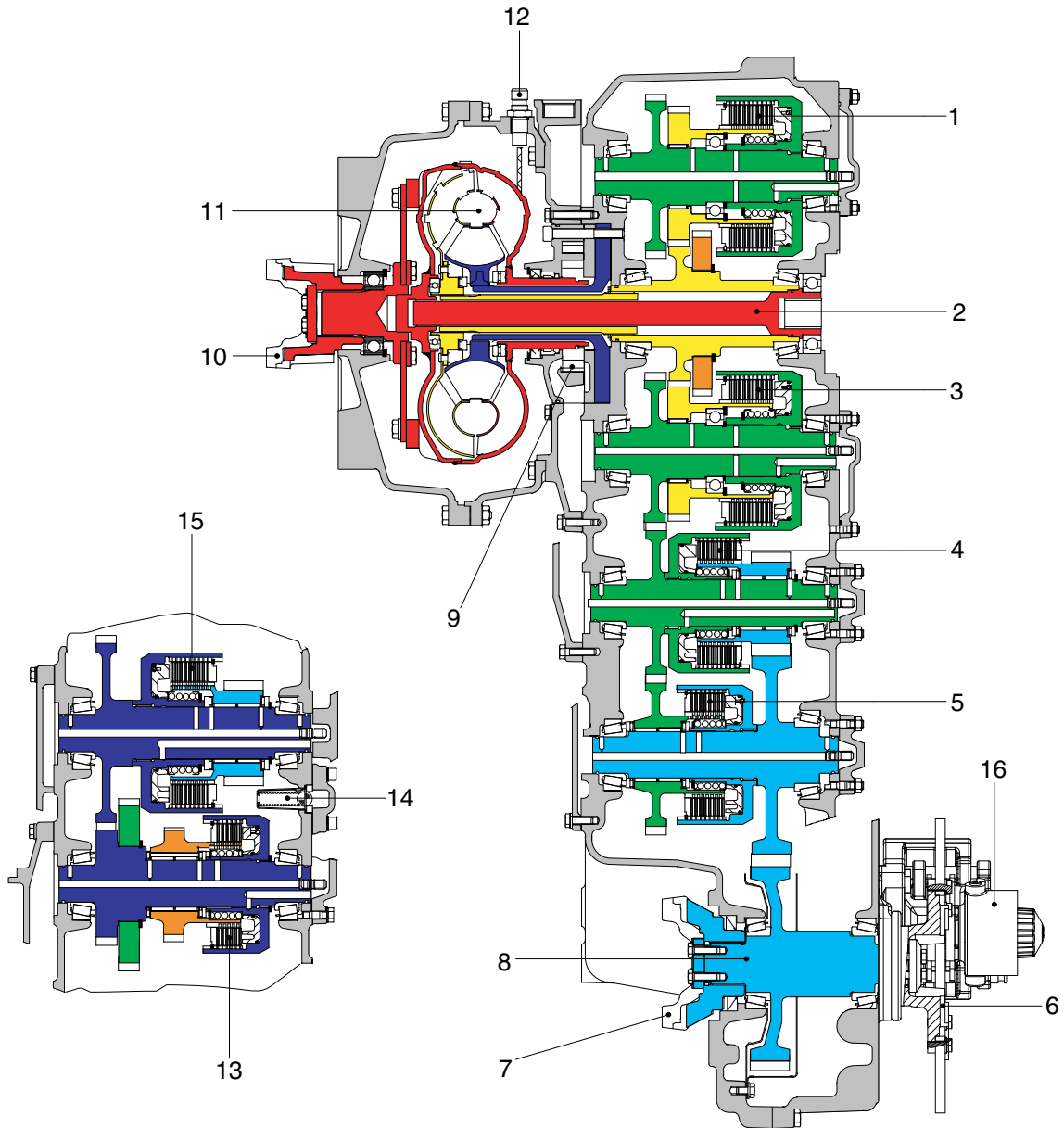

7309A3PT03

- | | | | | | |
|---|---------------------------------|----|------------------------------|----|--|
| 1 | Reverse clutch (KR) | 7 | Converter side output flange | 12 | Inductive transmitter for engine speed |
| 2 | Engine-dependent power take-off | 8 | Output shaft | 13 | 4th clutch (K4) |
| 3 | Forward clutch (KV) | 9 | Transmission pump | 14 | Converter relief valve |
| 4 | 2nd clutch (K2) | 10 | Connection to engine | 15 | 1st clutch (K1) |
| 5 | 3rd clutch (K3) | 11 | Converter | 16 | Parking brake |
| 6 | Rear output flange | | | | |

2) INSTALLATION VIEW

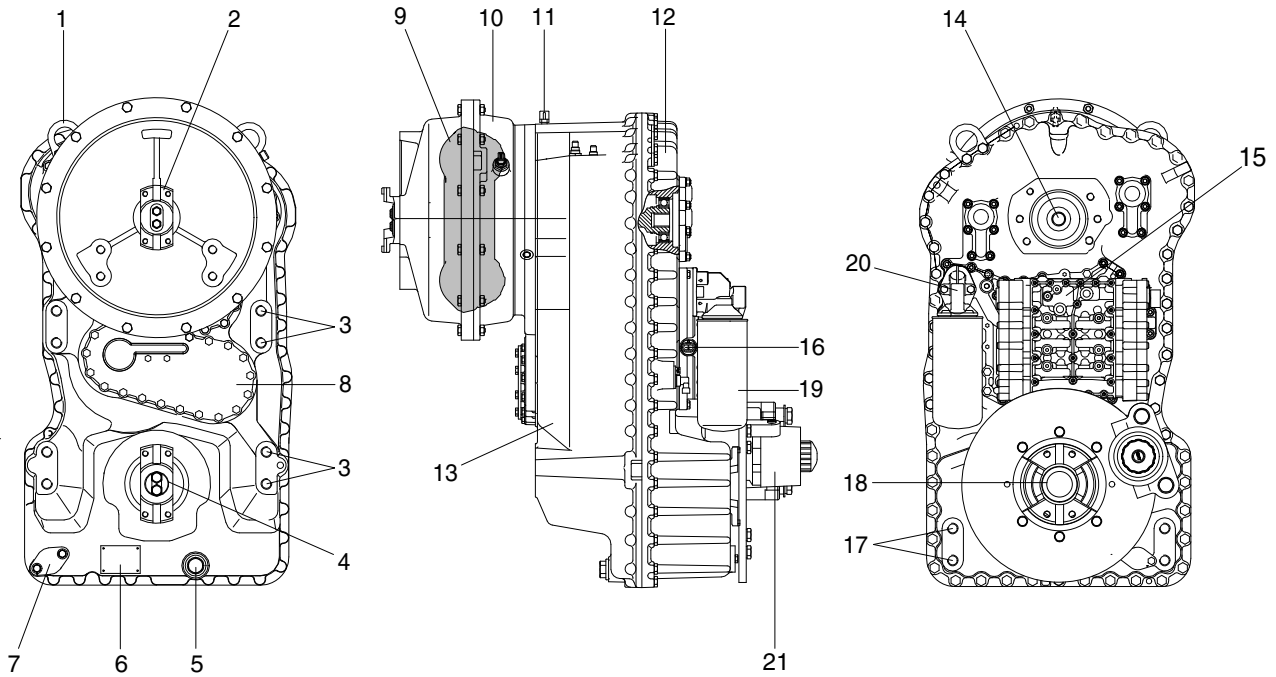

7309A3PT02

- | | | | |
|----|---|----|--|
| 1 | Lifting lugs | 13 | Transmission case |
| 2 | Connection to engine | 14 | Power take-off; Coaxial;
Engine-dependent |
| 3 | Transmission suspension threads M20 | 15 | Electro-hydraulic control |
| 4 | Output flange-converter side | 16 | Oil level tube with oil dipstick |
| 5 | Oil drain plug with magnetic insert M38×1.5 | 17 | Transmission suspension threads M20 |
| 6 | Model identification plate | 18 | Output flange-rear |
| 7 | Attachment possibility for oil level tube
with oil dipstick (converter side) | 19 | Exchange filter (fine filter) |
| 9 | Cover | 20 | Filter head with connection for filter
restriction switch |
| 10 | Converter bell housing | 21 | Parking brake |
| 11 | Breather | | |
| 12 | Transmission-case cover | | |

3) OPERATION OF TRANSMISSION

(1) Forward

① Forward 1st

In 1st forward, forward clutch (KV) and 1st clutch (K1) are engaged.

Forward clutch and 1st clutch are actuated by the hydraulic pressure applied to the clutch piston.

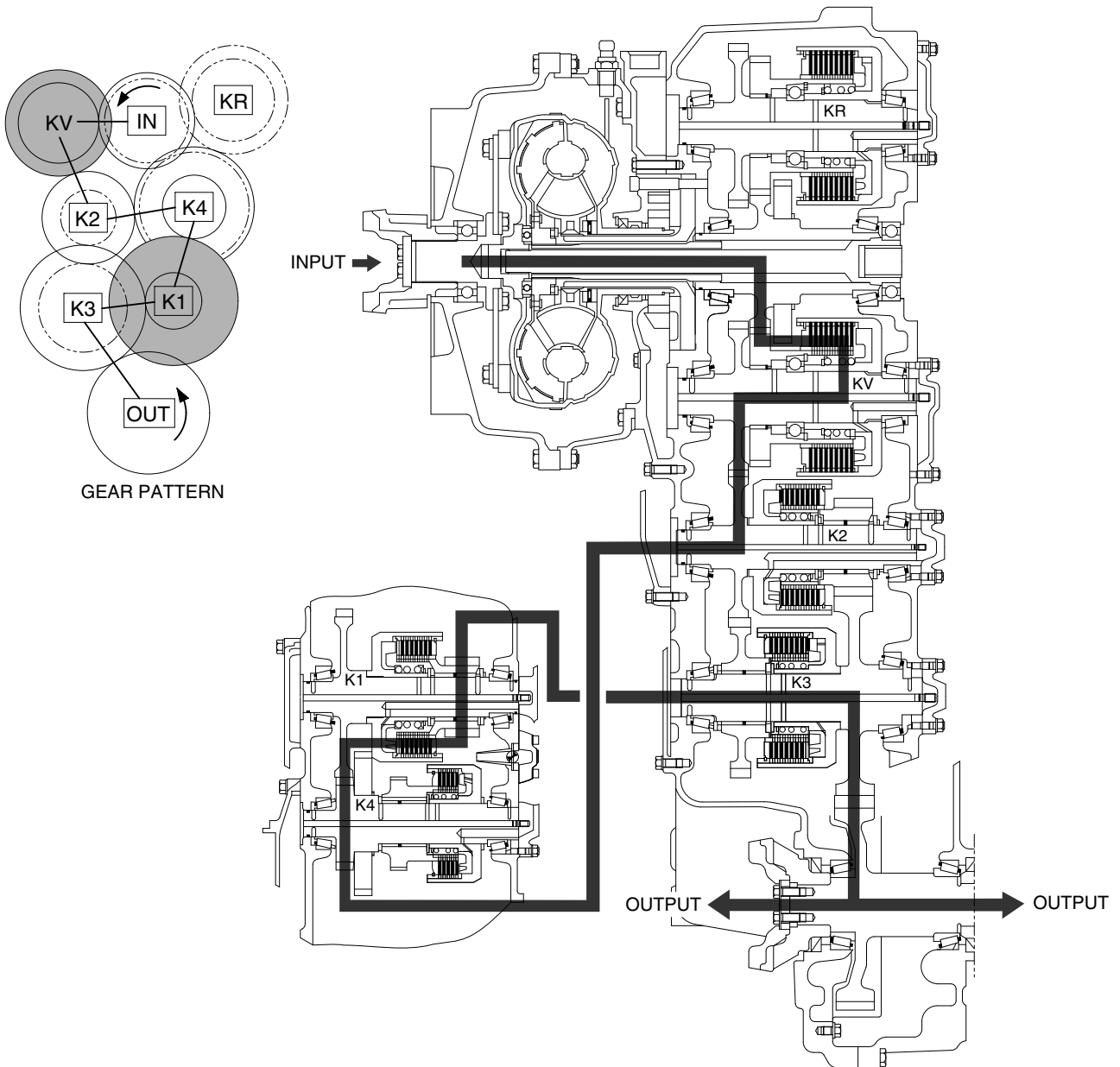

7309A3PT04

② Forward 2nd

In 2nd forward, forward clutch (KV) and 2nd clutch (K2) are engaged.

Forward clutch and 2nd clutch are actuated by the hydraulic pressure applied to the clutch piston.

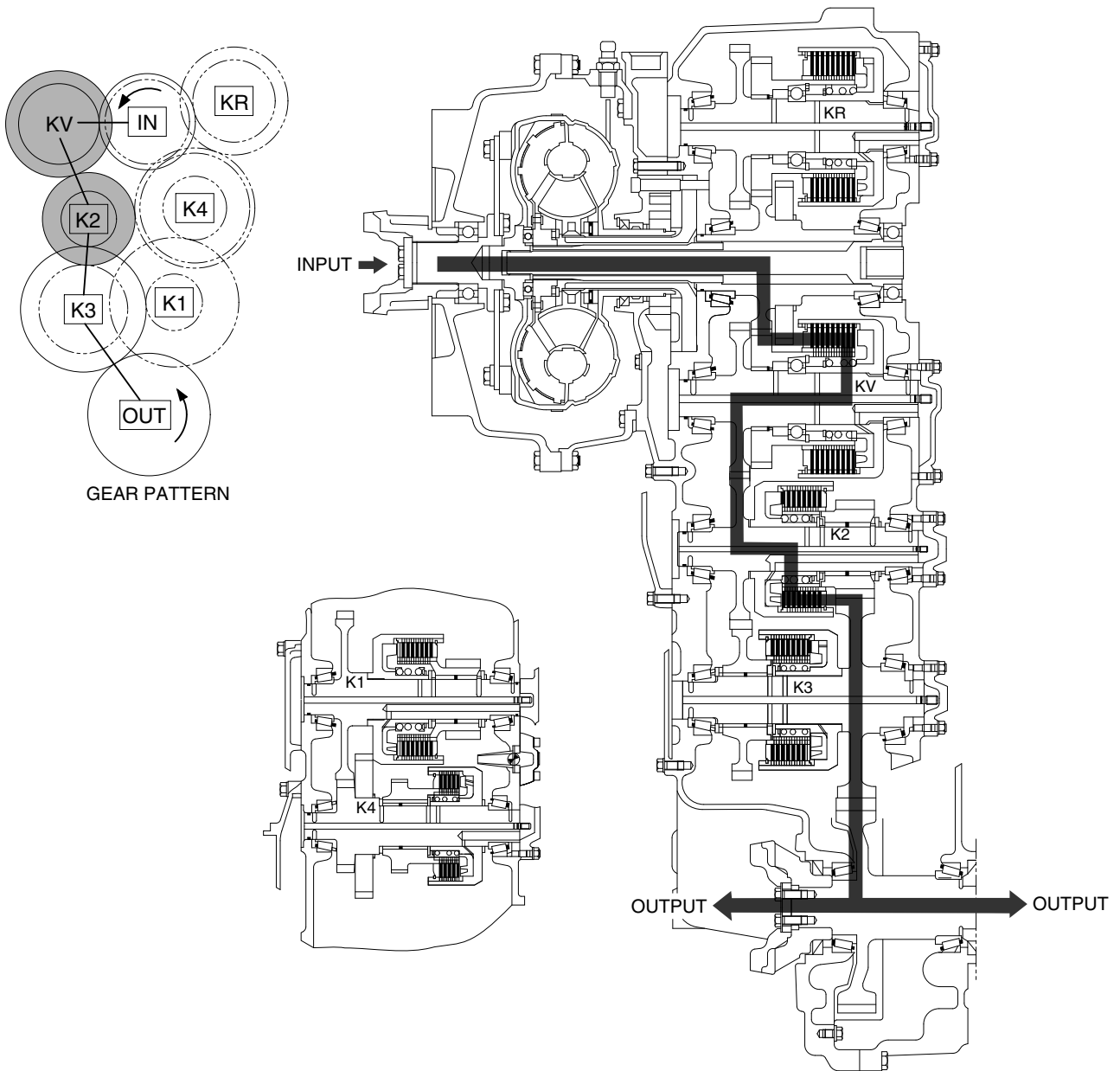

7309A3PT05

③ Forward 3rd

In 3rd forward, forward clutch (KV) and 3rd clutch (K3) are engaged.

Forward clutch and 3rd clutch are actuated by the hydraulic pressure applied to the clutch piston.

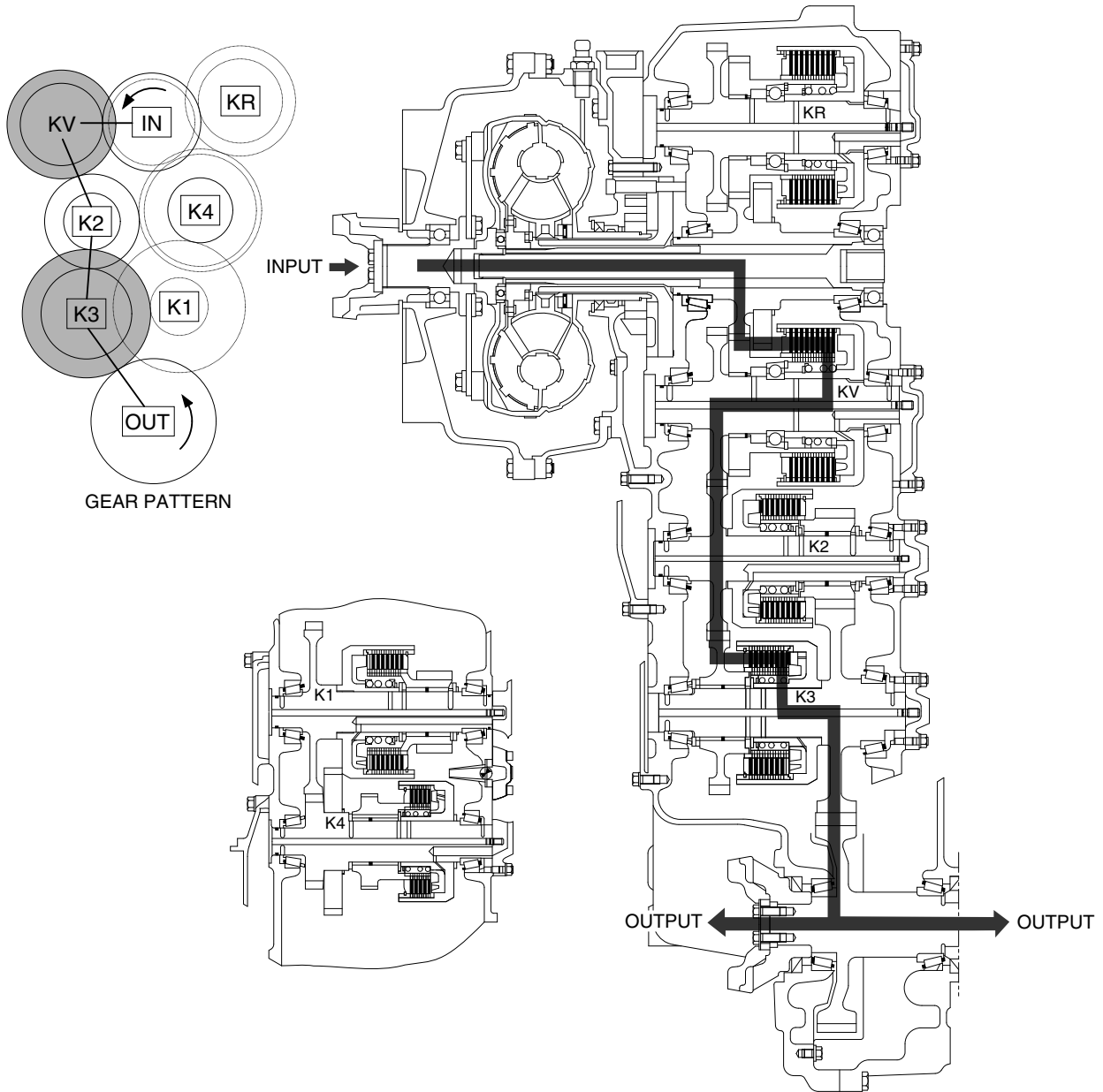

7309A3PT06

④ Forward 4th

In 4th forward, 4th clutch (K4) and 3rd clutch (K3) are engaged.

4th clutch and 3rd clutch are actuated by the hydraulic pressure applied to the clutch piston.

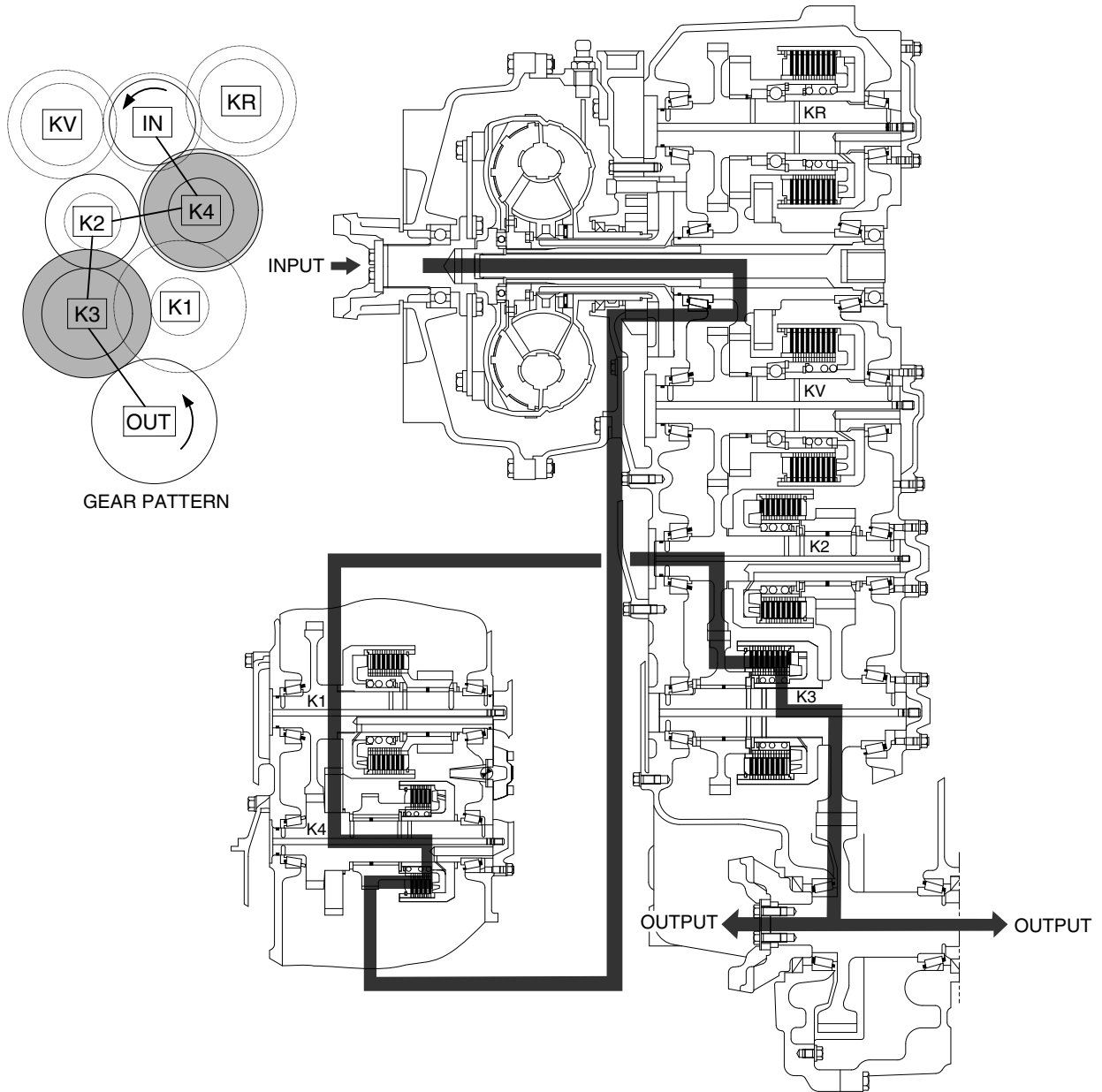

7309A3PT07

(2) Reverse

① Reverse 1st

In 1st reverse, reverse clutch (KR) and 1st clutch (K1) are engaged.

Reverse clutch and 1st clutch are actuated by the hydraulic pressure applied to the clutch piston.

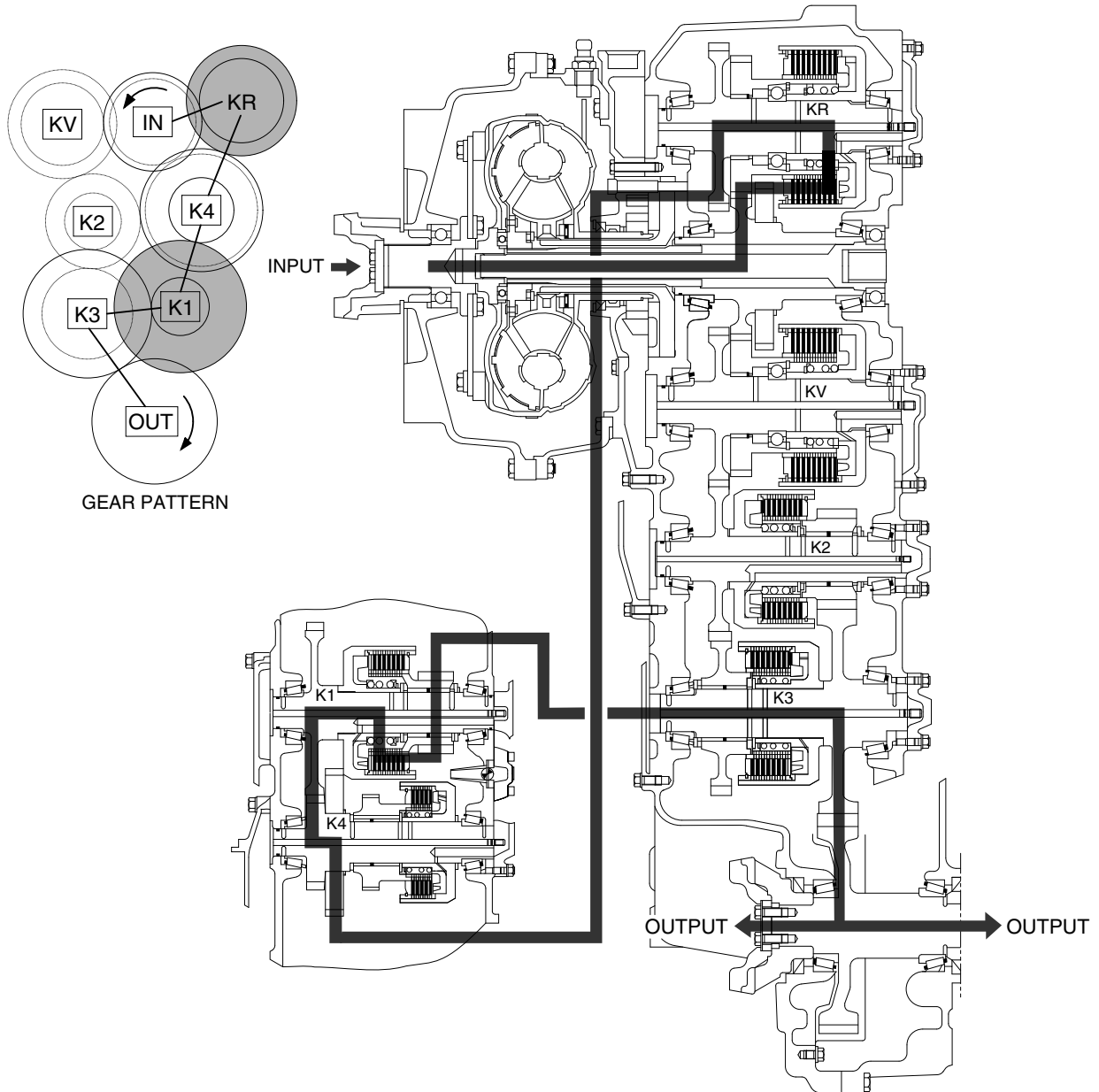

7309A3PT08

② Reverse 2nd

In 2nd reverse, reverse clutch (KR) and 2nd clutch (K2) are engaged.

Reverse clutch and 2nd clutch are actuated by the hydraulic pressure applied to the clutch piston.

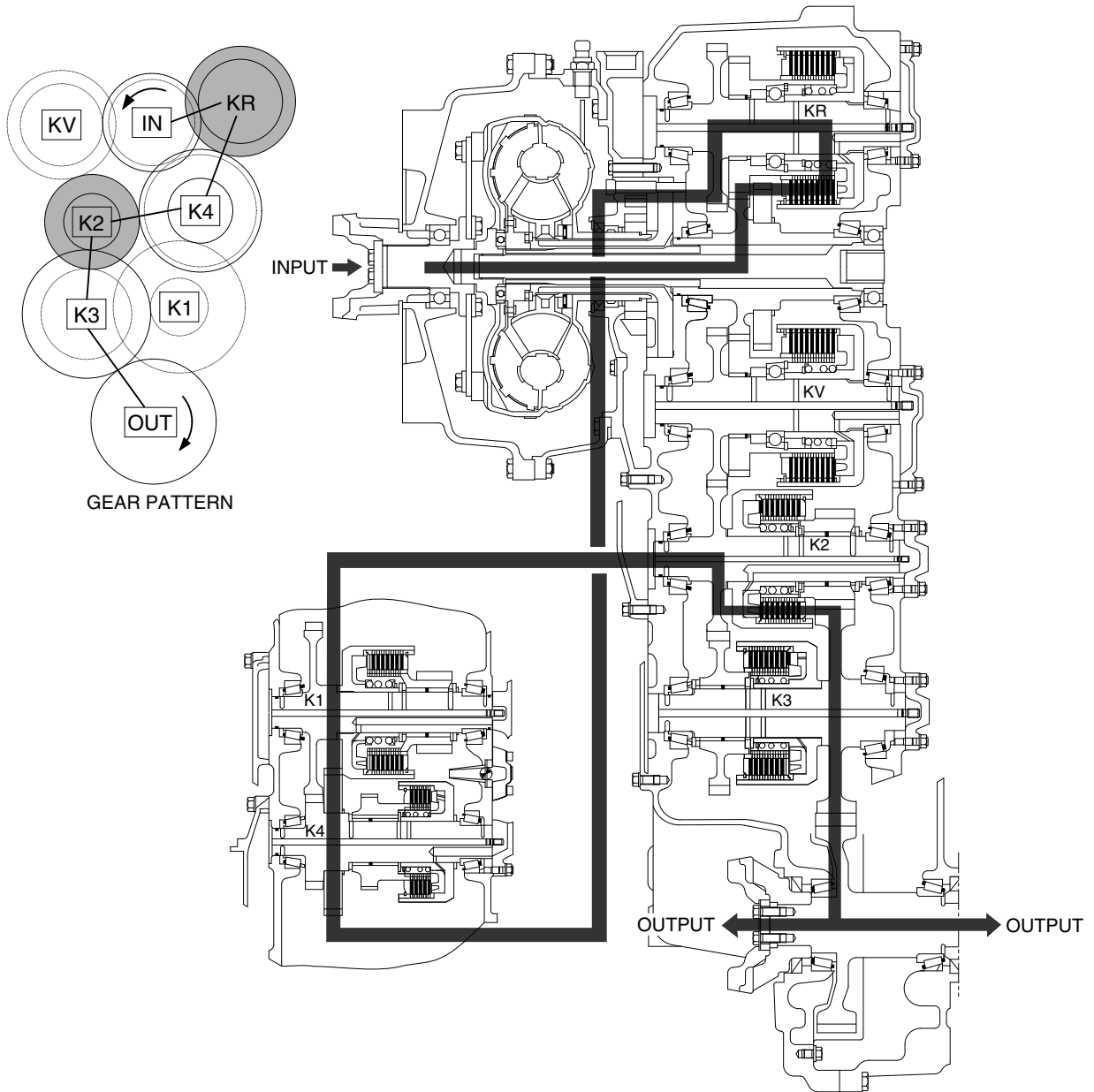

7309A3PT09

③ Reverse 3rd

In 3rd reverse, reverse clutch (KR) and 3rd clutch (K3) are engaged.

Reverse clutch and 3rd clutch are actuated by the hydraulic pressure applied to the clutch piston.

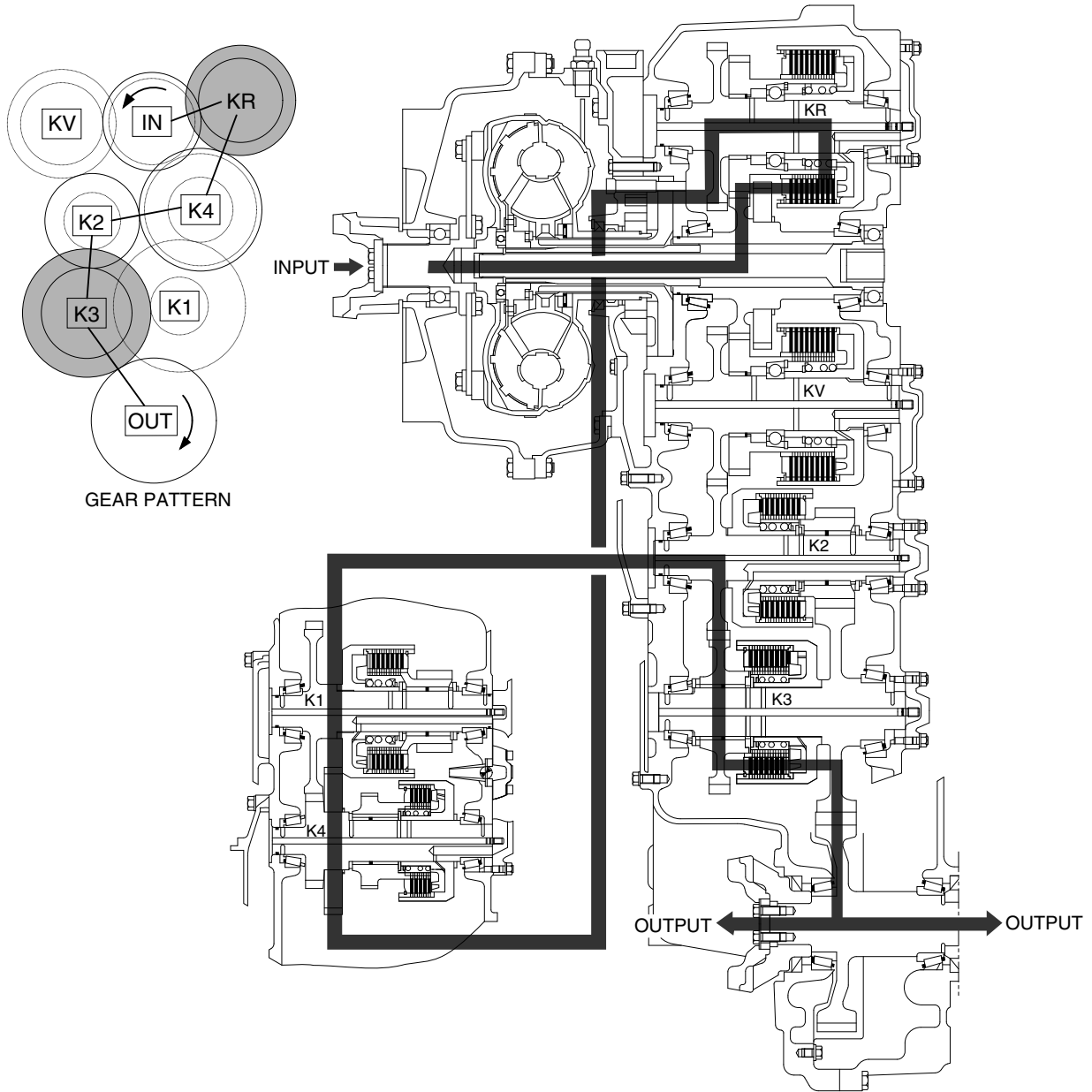

7309A3PT10

4) ELECTRO-HYDRAULIC SHIFT CONTROL WITH PROPORTIONAL VALVE

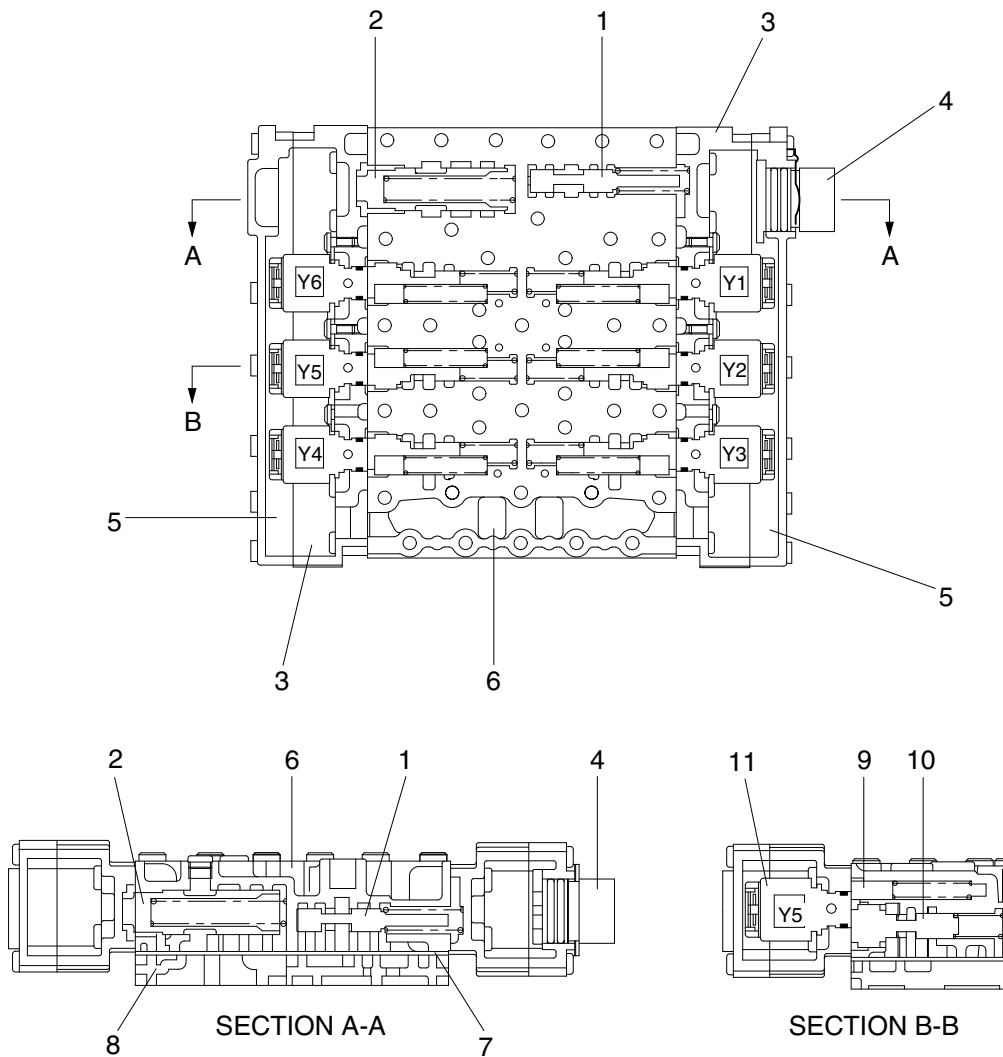

73033CV01

- | | | | |
|---|-----------------------------------|----|--------------------|
| 1 | Pressure reducing valve(9+0.5bar) | 7 | Intermediate sheet |
| 2 | System pressure valve(16+2bar) | 8 | Duct plate |
| 3 | Housing | 9 | Oscillation damper |
| 4 | Cable harness | 10 | Follow-on slide |
| 5 | Cover | 11 | Pressure regulator |
| 6 | Valve block | | |

Transmission control, see schedule of hydraulic circuit, electro-hydraulic control unit and measuring points at page 3-2, 3-14 and 3-75.

The six clutches of the transmission are selected via the 6 proportional valves P1 to P6. The proportional valve (pressure regulator unit) is composed of pressure regulator (e.g. Y1), follow-on slide and vibration damper.

The control pressure of 9 bar for the actuation of the follow-on slides is created by the pressure reducing valve. The pressure oil (16+2bar) is directed via the follow-on slide to the respective clutch.

Due to the direct proportional selection with separated pressure modulation for each clutch, the pressures to the clutches, which are engaged in the gear change, will be controlled. In this way, a hydraulic intersection of the clutches to be engaged and disengaged becomes possible.

This is creating spontaneous shiftings without traction force interruption.

At the shifting, the following criteria are considered:

- Speed of engine, turbine, central gear train and output.
- Transmission temperature.
- Shifting mode (Up-, down-, reverse shifting and speed engagement out of neutral).
- Load condition (full and part load, traction, overrun inclusive consideration of load cycles during the shifting).

The main pressure valve is limiting the maximum control pressure to 16+2 bar and releases the main stream to the converter and lubricating circuit.

In the inlet to the converter, a converter safety valve is installed which protects the converter from high internal pressures (opening pressure 11+2bar).

Within the converter, the oil serves to transmit the power according to the well-known hydrodynamic principle (see torque converter, page 3-3).

To avoid cavitation, the converter must be always completely filled with oil.

This is achieved by a converter back pressure back-up valve, rear-mounted to the converter, with an opening pressure of at least 4.3bar.

The oil, escaping out of the converter, is directed to a oil cooler.

The oil is directed from the oil cooler to the transmission and from there to the lubricating oil circuit, so that all lubricating points are supplied with cooled oil.

In the electro-hydraulic control unit are 6 pressure regulators installed.

5) GEAR SELECTOR (DW-3)

The gear selector is designed for the mounting on the left side of the steering column. The positions (speeds) 1 to 4 are selected by a rotary motion, the driving direction Forward (F)-Neutral (N)-Reverse (R) by tilting the gear selector lever.

The gear selector is also available with integrated kickdown push button.

For the protection from unintended start off, a neutral interlock is installed.

Position N - Gear selector lever blocked in this position.

Position D - Driving.

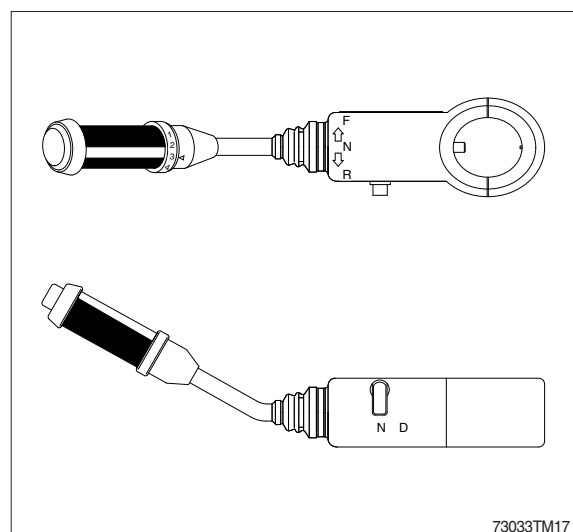

6) ELECTRIC CONTROL UNIT

(1) Complete system

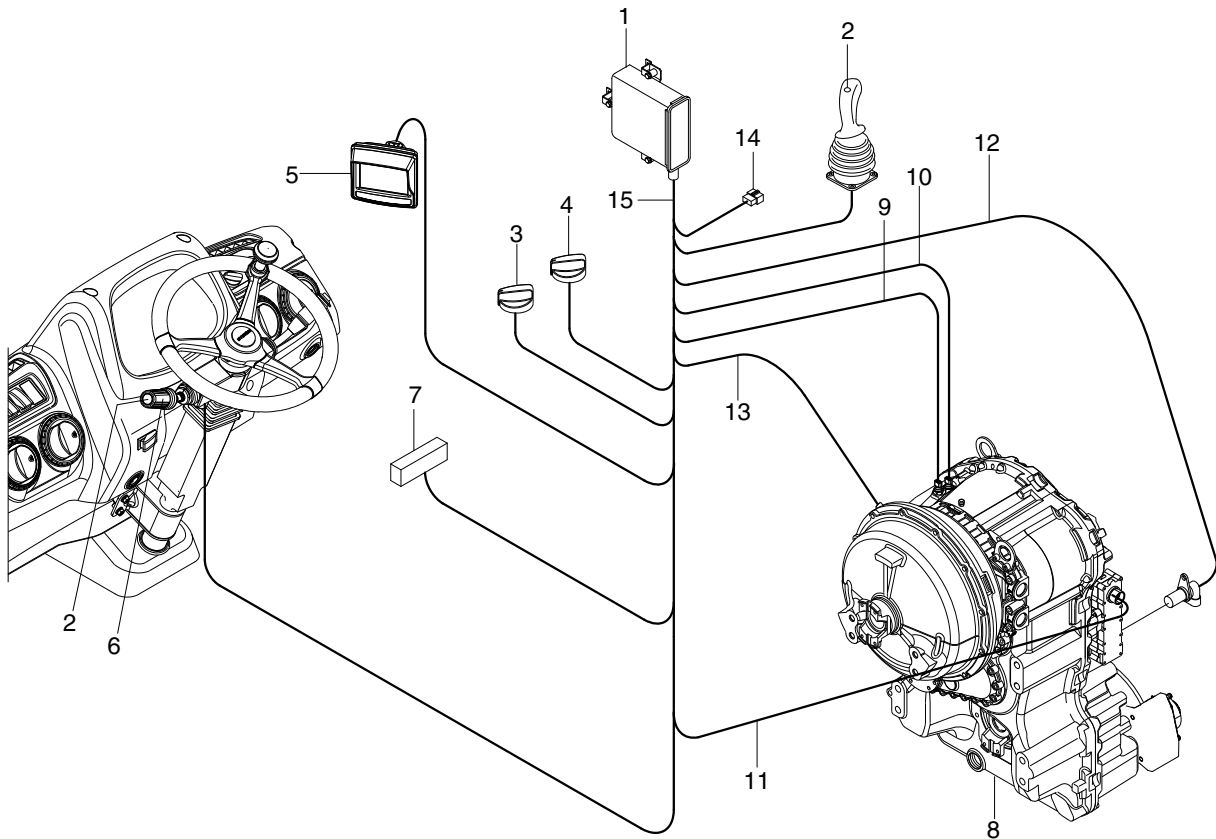

7309A3PT33

- 1 Transmission control unit (EST-37A)
- 2 Kickdown switch
- 3 Clutch cut off mode switch
- 4 Transmission shift mode switch
- 5 Monitor
- 6 Gear selector (DW-3) with integrated kickdown switch
- 7 Power supply connection
- 8 Transmission
- 9 Cable to inductive transmitter - speed central gear train
- 10 Cable to inductive transmitter - speed turbine
- 11 Cable to inductive transmitter - speed engine
- 12 Cable to speed sensor output and speedometer
- 13 Cable to plug connection on the electro - hydraulic control unit
- 14 CAN-Connection
- 15 Wiring

(2) Description of the basic functions

The powershift transmissions is equipped is electronic transmission control unit (EST-37A), developed for it.

The system is processing the desire of the driver according to the following criteria.

- Gear determination depending on controller position, driving speed and load condition.

- Protection from operating errors as far as necessary, is possible via electronic protection (programming).
- Protection from over-speeds (On the basis of engine and turbine speed).
- Automatic reversing (Driving speed-dependent).
- Pressure cut-off possible (disconnecting of the drive train for maximum power on the power take-off).
- Change-over possibility for Auto-/Manual mode.
- Kick down functions possible.

(3) Driving and shifting

- Neutral position :

Neutral position will be selected via the controller.

After the ignition is switched on, the electronics remains in the waiting state. By the position NEUTRAL of the controller, resp. by pressing the pushbutton NEUTRAL, the EST-37A becomes ready for operation.

Now, a gear can be engaged.

- Starting :

The starting of the engine has always to be carried out in the NEUTRAL POSITION of the controller.

For safety reasons it is to recommend to brake the machine securely in position with the parking brake prior to start the engine.

After the starting of the engine and the preselection of the driving direction and the gear, the machine can be set in motion by acceleration.

At the start off, the converter takes over the function of a master clutch.

On a level road it is possible to start off also in higher gears.

- Upshifting under load

Upshifting under load will be then realized if the machine can still accelerate by it.

- Downshifting under load

Downshifting under load will be realized if more traction force is needed.

- Upshifting in overrunning condition

In the overrunning mode, the upshifting will be suppressed by accelerator pedal idling position, if the speed of the machine on a downgrade should not be further increased.

- Downshifting in overrunning condition

Downshiftings in overrunning mode will be then carried out if the machine should be retarded.

If the machine will be stopped and is standing with running engine and engaged transmission, the engine cannot be stalled. On a level and horizontal roadway it is possible that the machine begins to crawl, because the engine is creating at idling speed a slight drag torque via the converter.

It is convenient to brake the machine at every stop securely in position with the parking brake.

At longer stops, the controller has to be shifted to the NEUTRAL POSITION.

At the start off, the parking brake has to be released. We know from experience that at a converter transmission it might not immediately be noted to have forgotten this quite normal operating step because a converter, due to its high ratio, can easily overcome the braking torque of the parking brake.

Temperature increases in the converter oil as well as overheated brakes will be the consequences to be find out later.

Neutral position of the selector switch at higher machine speeds (above stepping speed) is not admissible.

Either a suitable gear is to be shifted immediately, or the machine must be stopped at once.

(4) Independent calibration of the shifting elements (AEB)

The AEB has the task to compensate tolerances (plate clearance and pressure level) which are influencing the filling procedure of the clutches. For each clutch, the correct filling parameters are determined in one test cycle for :

- Period of the quick-filling time
- Level of the filling compensating pressure

The filling parameters are stored, together with the AEB-program and the driving program in the transmission electronics. Because the electronics will be separately supplied, the AEB-cycle must be started only after the installation of both components in the machine, thus ensuring the correct mating (Transmission and electronics).

※ It is imperative, to respect the following test conditions :

- Shifting position neutral
- Engine in idling speed
- Parking brake actuated
- Transmission in operating temperature

※ After a replacement of the transmission, the electrohydraulic control or the TCU in the machine, the AEB-cycle must be as well carried out again.

The AEB-cycle continues for about 3 to 4 minutes. The determined filling parameters are stored in the EEPROM of the electronics. In this way, the error message F6 shown on the display will be cancelled also at non-performed AEB.

(5) Pressure cut-off

In order to provide the full engine power for the hydraulic system, the control can be enlarged for the function of a pressure cut-off in the 1st and 2nd speed. In this way, the pressure in the powershift clutches will be cut-off, and the torque transmission in the drive train will be eliminated by it. This function will be released at the actuation of a switch, arranged on the brake pedal.

For a soft restart, the pressure will be build-up via a freely programmable characteristic line.

4. FAULT CODE

1) MACHINE FAULT CODE

HCESPN	FMI	Description
101	3	Hydraulic oil temperature sensor circuit - Voltage above normal, or shorted to high source (or open circuit)
	4	Hydraulic oil temperature sensor circuit - Voltage below normal, or shorted to low source
145	5	Engine cooling fan EPPR valve circuit - Current below normal, or open circuit
	6	Engine cooling fan EPPR valve circuit - Current above normal
172	4	Boom up lever detent solenoid circuit - Voltage below normal, or shorted to low source (or open circuit)
	6	Boom up lever detent solenoid circuit - Current above normal
173	4	Boom down lever detent solenoid circuit - Voltage below normal, or shorted to low source (or open circuit)
	6	Boom down lever detent solenoid circuit - Current above normal
174	4	Bucket lever detent solenoid circuit - Voltage below normal, or shorted to low source (or open circuit)
	6	Bucket lever detent solenoid circuit - Current above normal
181	4	Engine cooling fan reverse solenoid circuit - Voltage below normal, or shorted to low source (or open circuit)
	6	Engine cooling fan reverse solenoid circuit - Current above normal
183	4	Engine cooling fan reverse driving status signal circuit - Voltage below normal, or shorted to low source (or open circuit)
	6	Engine cooling fan reverse driving status signal circuit - Current above normal
187	4	Emergency steering pump relay circuit - Voltage below normal, or shorted to low source (or open circuit)
	6	Emergency steering pump relay circuit - Current above normal
202	0	Steering main pump pressure sensor data above normal range (or open circuit)
	1	Steering main pump pressure sensor data below normal range
	2	Steering main pump pressure sensor data error
	4	Steering main pump pressure sensor circuit - Voltage below normal, or shorted to low source
203	0	Emergency steering pump pressure sensor data above normal range (or open circuit)
	1	Emergency steering pump pressure sensor data below normal range
	2	Emergency steering pump pressure sensor data error
	4	Emergency steering pump pressure sensor circuit - Voltage below normal, or shorted to low source
204	0	Boom cylinder pressure sensor data above normal range (or open circuit)
	1	Boom cylinder pressure sensor data below normal range
	2	Boom cylinder pressure sensor data error
	4	Boom cylinder pressure sensor circuit - Voltage below normal, or shorted to low source
205	0	Bucket cylinder pressure sensor data above normal range (or open circuit)
	1	Bucket cylinder pressure sensor data below normal range
	2	Bucket cylinder pressure sensor data error
	4	Bucket cylinder pressure sensor circuit - Voltage below normal, or shorted to low source

HCESPN	FMI	Description
301	3	Fuel level sensor circuit - Voltage above normal, or shorted to high source (or open circuit)
	4	Fuel level sensor circuit - Voltage below normal, or shorted to low source
304	3	Engine coolant temperature sensor circuit - Voltage above normal, or shorted to high source (or open circuit)
	4	Engine coolant temperature sensor circuit - Voltage below normal, or shorted to low source
310	8	Engine speed signal error – Abnormal frequency or pulse width
318	8	Engine cooling fan speed signal error – Abnormal frequency or pulse width
322	4	Engine preheat relay circuit – Voltage below normal, or shorted to low source (or open circuit)
	6	Engine preheat relay circuit - Current above normal
325	4	Fuel warmer relay circuit - Voltage below normal, or shorted to low source (or open circuit)
	6	Fuel warmer relay circuit – Current above normal
327	4	Anti-restart relay circuit - Voltage below normal, or shorted to low source (or open circuit)
	6	Anti-restart relay circuit – Current above normal
346	3	Engine power mode selector circuit – Voltage above normal, or shorted to high source (or open circuit)
	4	Engine power mode selector circuit – Voltage below normal, or shorted to low source
503	0	Brake oil pressure sensor data above normal range (or open circuit)
	1	Brake oil pressure sensor data below normal range
	2	Brake oil pressure sensor data error
	4	Brake oil pressure sensor circuit – Voltage below normal, or shorted to Low Source
507	0	Parking oil pressure sensor data above normal range (or open circuit)
	1	Parking oil pressure sensor data below normal range
	2	Parking oil pressure sensor data error
	4	Parking oil pressure sensor circuit - Voltage below normal, or shorted to low source
551	3	Clutch cut off mode selector circuit – Voltage above normal, or shorted to high source (or open circuit)
	4	Clutch cut off mode selector circuit – Voltage below normal, or shorted to low source
552	3	Transmission shift mode selector circuit – Voltage above normal, or shorted to high source (or open circuit)
	4	Transmission shift mode selector circuit – Voltage below normal, or shorted to low source
558	0	Differential lock pressure sensor data above normal range (or open circuit)
	1	Differential lock pressure sensor data below normal range
	2	Differential lock pressure sensor data error
	4	Differential lock pressure sensor circuit - Voltage below normal, or shorted to low source
701	4	Hourmeter circuit - Voltage below normal, or shorted to low source
705	0	Battery voltage high
	1	Battery voltage low

HCESPN	FMI	Description
707	1	Alternator node I voltage low (or open circuit)
723	3	Buzzer circuit - Voltage above normal, or shorted to high source
	4	Buzzer circuit - Voltage below normal, or shorted to low source (or open circuit)
727	4	Wiper relay circuit - Voltage below normal, or shorted to low source (or open circuit)
	6	Wiper relay circuit – Current above normal
728	3	Boom position sensor signal circuit – Voltage above normal, or shorted to high source (or open circuit)
	4	Boom position sensor signal circuit – Voltage below normal, or shorted to low source
729	3	Bucket position sensor signal circuit – Voltage above normal, or shorted to high source (or open circuit)
	4	Bucket position sensor signal circuit – Voltage below normal, or shorted to low source
730	19	APTC heater PWM output duty operation error
830	12	MCU internal memory error
840	2	Cluster communication error
841	2	ECM communication error
842	2	TCU communication error
843	2	APTC communication error
844	2	Monitor communication error
850	2	RMCU communication error

2) ENGINE FAULT CODE

Fault code J1939 SPN J1939 FMI	Reason	Effect (only when fault code is active)
111 629 12	Engine control module critical internal failure - Bad intelligent device or component. Error internal to the ECM related to memory hardware failures or internal ECM voltage supply circuits.	Possible no noticeable performance effects, engine dying, or hard starting.
115 612 2	Engine magnetic crankshaft speed/position lost both of two signals - Data erratic, intermittent, or incorrect. The ECM has detected that the primary engine speed sensor and the backup engine speed sensor signals are reversed.	Fueling to injectors is disabled and the engine can not be started.
122 102 3	Intake manifold 1 pressure sensor circuit - Voltage above normal, or shorted to high source. High signal voltage detected at the intake manifold pressure circuit.	Engine power derate.
123 102 4	Intake manifold 1 pressure sensor circuit - Voltage below normal, or shorted to low Source. Low signal voltage or open circuit detected at the intake manifold pressure circuit.	Engine power derate.
124 102 16	Intake manifold 1 pressure - Data valid but above normal operational range - Moderately severe level. Intake manifold pressure has exceeded the maximum limit for the given engine rating.	Engine power derate.
131 91 3	Accelerator pedal or lever position sensor 1 circuit - Voltage above normal, or shorted to high source. High voltage detected at accelerator pedal position circuit.	Severe derate in power output of the engine. Limp home power only.
132 91 4	Accelerator pedal or lever position sensor 1 circuit - Voltage below normal, or shorted to low source. Low voltage detected at accelerator pedal position signal circuit.	Severe derate in power output of the engine. Limp home power only.
133 974 3	Remote accelerator pedal or lever position sensor 1 circuit - Voltage above normal, or shorted to high source. High voltage detected at remote accelerator pedal position circuit.	Remote accelerator will not operate. Remote accelerator position will be set to zero percent.
134 974 4	Remote accelerator pedal or lever position sensor 1 circuit - Voltage below normal, or shorted to low source. Low voltage detected at remote accelerator pedal position signal circuit.	Remote accelerator will not operate. Remote accelerator position will be set to zero percent.
135 100 3	Engine oil rifle pressure 1 sensor circuit - Voltage above normal, or shorted to high source. High signal voltage detected at the engine oil pressure circuit.	None on performance. No engine protection for oil pressure.
141 100 4	Engine oil rifle pressure 1 sensor circuit - Voltage below normal, or shorted to low source. Low signal voltage detected at engine oil pressure circuit.	None on performance. No engine protection for oil pressure.
143 100 18	Engine oil rifle pressure - Data valid but below normal operational range - Moderately severe level. Engine oil pressure signal indicates engine oil pressure is below the engine protection warning limit.	Engine power derate.

※ Some fault codes are not applied to this machine.

Fault code J1939 SPN J1939 FMI	Reason	Effect (only when fault code is active)
144 110 3	Engine coolant temperature 1 sensor circuit - Voltage above normal, or shorted to high source. High signal voltage or open circuit detected at engine coolant temperature circuit.	Possible white smoke. Fan will stay ON if controlled by ECM. No engine protection for engine coolant temperature.
145 110 4	Engine Coolant Temperature 1 Sensor Circuit - Voltage Below Normal, or Shorted to Low Source. Low signal voltage detected at engine coolant temperature circuit.	Possible white smoke. Fan will stay ON if controlled by ECM. No engine protection for engine coolant temperature.
146 110 16	Engine Coolant Temperature - Data Valid but Above Normal Operational Range - Moderately Severe Level. Engine coolant temperature signal indicates engine coolant temperature is above engine protection warning limit.	Progressive power derate increasing in severity from time of alert.
147 91 1	Accelerator Pedal or Lever Position 1 Sensor Circuit Frequency - Data Valid but Below Normal Operational Range - Most Severe Level. A frequency of less than 100 Hz has been detected at the frequency throttle input to the ECM.	Severe derate in power output of the engine. Limp home power only.
148 91 0	Accelerator Pedal or Lever Position Sensor 1 - Data Valid but Above Normal Operational Range - Most Severe Level. A frequency of more than 1500 Hz has been detected at the frequency throttle input to the ECM.	Severe derate in power output of the engine. Limp home power only.
151 110 0	Engine Coolant Temperature - Data Valid but Above Normal Operational Range - Most Severe Level. Engine coolant temperature signal indicates engine coolant temperature above engine protection critical limit.	Progressive power derate increasing in severity from time of alert. If Engine Protection Shutdown feature is enabled, engine will shut down 30 seconds after Red Stop Lamp starts flashing.
153 105 3	Intake Manifold 1 Temperature Sensor Circuit - Voltage Above Normal, or Shorted to High Source. High signal voltage detected at intake manifold air temperature circuit.	Possible white smoke. Fan will stay ON if controlled by ECM. No engine protection for intake manifold air temperature.
154 105 4	Intake Manifold 1 Temperature Sensor Circuit - Voltage Below Normal, or Shorted to Low Source. Low signal voltage detected at intake manifold air temperature circuit.	Possible white smoke. Fan will stay ON if controlled by ECM. No engine protection for intake manifold air temperature.
155 105 0	Intake Manifold 1 Temperature - Data Valid but Above Normal Operational Range - Most Severe Level. Intake manifold air temperature signal indicates intake manifold air temperature above engine protection critical limit.	Progressive power derate increasing in severity from time of alert. If Engine Protection Shutdown feature is enabled, engine will shut down 30 seconds after Red Stop Lamp starts flashing.
187 3510 4	Sensor Supply 2 Circuit - Voltage Below Normal, or Shorted to Low Source. Low voltage detected at the sensor supply number 2 circuit.	Engine power derate.
195 111 3	Coolant Level Sensor 1 Circuit - Voltage Above Normal, or Shorted to High Source. High signal voltage detected at engine coolant level circuit.	None on performance.
196 111 4	Coolant Level Sensor 1 Circuit - Voltage Below Normal, or Shorted to Low Source. Low signal voltage detected at engine coolant level circuit.	None on performance.

※ Some fault codes are not applied to this machine.

Fault code J1939 SPN J1939 FMI	Reason	Effect (only when fault code is active)
197 111 18	Coolant Level - Data Valid but Below Normal Operational Range - Moderately Severe Level. Low coolant level has been detected.	Possible power derate and possible engine shutdown if the Engine Protection Shutdown feature is enabled.
221 108 3	Barometric Pressure Sensor Circuit - Voltage Above Normal, or Shorted to High Source. High signal voltage detected at barometric pressure circuit.	Engine power derate.
222 108 4	Barometric Pressure Sensor Circuit - Voltage Below Normal, or Shorted to Low Source. Low signal voltage detected at barometric pressure circuit.	Engine power derate.
227 3510 3	Sensor Supply 2 Circuit - Voltage Above Normal, or Shorted to High Source. High voltage detected at sensor supply number 2 circuit.	Engine power derate.
234 190 0	Engine Crankshaft Speed/Position - Data Valid but Above Normal Operational Range - Most Severe Level. Engine speed signal indicates engine speed above engine protection limit.	Fuel injection disabled until engine speed falls below the overspeed limit.
235 111 1	Coolant Level - Data Valid but Below Normal Operational Range - Most Severe Level. Low engine coolant level detected.	Engine protection shutdown.
238 3511 4	Sensor Supply 3 Circuit - Voltage Below Normal, or Shorted to Low Source. Low voltage detected on the +5 volt sensor supply circuit to the engine speed sensor.	Possible hard starting and rough running.
239 3511 3	Sensor Supply 3 Circuit - Voltage Above Normal or Shorted to High Source. High voltage detected on the 5 volt sensor supply circuit to the engine speed sensor.	Possible hard starting and rough running.
241 84 2	Wheel-based vehicle speed - Data erratic, intermittent, or incorrect. The ECM lost the vehicle speed signal.	Engine speed limited to ,maximum engine speed without VSS parameter value. Cruise control, gear-down protection, and road speed governor will not work.
245 647 4	Fan control circuit - Voltage below normal, or shorted to low source. Low signal voltage detected at the fan control circuit when commanded on.	The fan may stay on continuously or not run at all.
271 1347 4	Fuel pump pressurizing assembly 1 circuit - Voltage below normal, or shorted to low source. Low signal voltage detected at the fuel pump actuator circuit.	Engine will run poorly at idle. Engine will have low power. Fuel pressure will be higher than commanded.
272 1347 3	Fuel pump pressurizing assembly 1 circuit - Voltage above normal, or shorted to high source. High signal voltage or open circuit detected at the fuel pump actuator circuit.	Engine will not run or engine will run poorly.
281 1347 7	Fuel pump pressurizing assembly 1 - Mechanical system not responding properly or out of adjustment.	Engine will not run or possible low power.

※ Some fault codes are not applied to this machine.

Fault code J1939 SPN J1939 FMI	Reason	Effect (only when fault code is active)
285 639 9	SAE J1939 multiplexing PGN timeout error - Abnormal update rate. The ECM expected information from a multiplexed device but did not receive it soon enough or did not receive it at all.	At least one multiplexed device will not operate properly.
286 639 13	SAE J1939 multiplexing configuration error - Out of calibration. The ECM expected information from a multiplexed device but only received a portion of the necessary information.	At least one multiplexed device will not operate properly.
287 91 19	SAE J1939 multiplexed accelerator pedal or lever sensor system - received network data In error. The OEM vehicle electronic control unit (VECM) detected a fault with its accelerator pedal.	Engine may only idle or engine will not accelerate to full speed.
288 974 19	SAE J1939 Multiplexing Remote Accelerator Pedal or Lever Position Sensor Circuit - Received Network Data In Error. The OEM vehicle electronic control unit (VECM) detected a fault with the remote accelerator.	The engine will not respond to the remote throttle. Engine may only idle. The primary or cab accelerator may be able to be used.
292 441 14	Auxiliary temperature Sensor Input 1 - Special instructions.	Possible engine power derate.
293 441 3	Auxiliary temperature sensor input 1 circuit - Voltage above normal, or shorted to high source. High signal voltage or open circuit detected at the OEM auxiliary temperature circuit.	None on performance.
294 441 4	Auxiliary temperature sensor input 1 circuit - Voltage below normal, or shorted to low source. Low signal voltage detected at the OEM auxiliary temperature circuit.	None on performance.
295 108 2	Barometric Pressure - Data Erratic, Intermittent, or Incorrect. An error in the barometric pressure sensor signal was detected by the ECM.	Engine power derate.
296 1388 14	Auxiliary pressure sensor input 2 - Special instructions.	Possible engine power derate.
297 1388 3	Auxiliary pressure sensor input 2 circuit - Voltage above normal, or shorted to high source. High signal voltage detected at the OEM pressure circuit.	None on performance.
298 1388 4	Auxiliary pressure sensor input 2 circuit - Voltage below normal, or shorted to low source. Low signal voltage or open circuit detected at the OEM pressure circuit.	None on performance.
319 251 2	Real time clock power interrupt - Data erratic, intermittent, or incorrect. Real time clock lost power.	None on performance. Data in the ECM will not have accurate time and date information.
322 651 5	Injector solenoid driver cylinder 1 circuit - Current below normal, or open circuit. Current detected at injector 1 when voltage is turned OFF.	The current to the injector is shut OFF. The engine can possibly misfire or run rough.

※ Some fault codes are not applied to this machine.

Fault code J1939 SPN J1939 FMI	Reason	Effect (only when fault code is active)
323 656 5	Injector solenoid driver cylinder 5 circuit - Current below normal, or open circuit. Current detected at injector 5 when voltage is turned OFF.	The current to the injector is shut OFF. The engine can possibly misfire or run rough.
324 653 5	Injector solenoid driver cylinder 3 circuit - Current below normal, or open circuit. Current detected at injector 3 when voltage is turned OFF.	The current to the injector is shut OFF. The engine can possibly misfire or run rough.
325 656 5	Injector solenoid driver cylinder 6 circuit - Current below normal, or open circuit. Current detected at injector 6 when voltage is turned OFF.	The current to the injector is shut OFF. The engine can possibly misfire or run rough.
331 652 5	Injector solenoid driver cylinder 2 circuit - Current below normal, or open circuit. Current detected at injector 2 when voltage is turned OFF.	The current to the injector is shut OFF. The engine can possibly misfire or run rough.
332 654 5	Injector solenoid driver cylinder 4 circuit - Current below normal, or open circuit. Current detected at injector 4 when voltage is turned OFF.	The current to the injector is shut OFF. The engine can possibly misfire or run rough.
334 110 2	Engine coolant temperature - Data erratic, intermittent, or incorrect. The engine coolant temperature reading is not changing with engine operating conditions.	The ECM will estimate engine coolant temperature.
342 630 13	Electronic calibration code incompatibility - Out of calibration. An incompatible calibration has been detected in the ECM.	Possible no noticeable performance effects, engine dying, or hard starting.
343 629 12	Engine control module warning internal hardware failure - Bad intelligent device or component. Internal ECM failure.	No performance effects or possible severe power derate.
351 627 12	Injector power supply - Bad intelligent device or component. The ECM measured injector boost voltage is low.	Possible smoke, low power, engine misfire, and/or engine will not start.
352 3509 4	Sensor supply 1 circuit - Voltage below normal, or shorted to low source. Low voltage detected at sensor supply number 1 circuit.	Engine power derate.
386 3509 3	Sensor supply 1 circuit - Voltage above normal, or shorted to high source. High voltage detected at sensor supply number 1 circuit.	Engine power derate.
415 100 1	Engine oil rifle pressure - Data valid but below normal operational range - Most severe level. Oil pressure signal indicates oil pressure below the engine protection critical limit.	Progressive power derate increasing in severity from time of alert. If engine protection shutdown feature is enabled, engine will shut down 30 seconds after red stop lamp starts flashing.
418 97 15	Water in fuel indicator - Data valid but above normal operational range - Least severe level. water has been detected in the fuel filter.	Possible white smoke, loss of power, or hard starting.
421 175 0	Engine Oil Temperature - Data Valid But Above Normal Operating Range - Most Severe Level. Engine oil temperature signal indicates engine oil temperature above engine protection critical limit.	Progressive speed derate increasing in severity from time of alert. If the Engine Protection Shutdown feature is enabled, engine will shut down 30 seconds after red STOP lamp starts flashing.

※ Some fault codes are not applied to this machine.

Fault code J1939 SPN J1939 FMI	Reason	Effect (only when fault code is active)
426 639 2	SAE J1939 Data Link-Data Erratic, Intermittent, or Incorrect. Communication between the ECM and another device on the SAE J1939 data link has been lost.	None on performance. SAE J1939 data link devices possibly do not operate.
428 97 3	Water in fuel indicator sensor circuit - Voltage above normal, or shorted to high source. High voltage detected at the water in fuel circuit.	None on performance. No water in fuel warning available.
429 97 4	Water in fuel indicator sensor circuit - Voltage below normal, or shorted to low source. Low voltage detected at the water in fuel circuit.	None on performance. No water in fuel warning available.
431 558 2	Accelerator pedal or lever idle validation switch - Data erratic, intermittent, or incorrect. Voltage detected simultaneously on both idle validation and off-idle validation switches.	Engine will only idle.
432 558 13	Accelerator pedal or lever idle validation circuit - Out of calibration. Voltage at idle validation on-idle and off-idle circuit does not match accelerator pedal position.	Engine will only idle.
435 100 2	Engine oil rifle pressure - Data erratic, intermittent, or incorrect. An error in the engine oil pressure switch signal was detected by the ECM.	None on performance. No engine protection for oil pressure.
441 168 18	Battery 1 voltage - Data valid but below normal operational range - Moderately severe level. ECM supply voltage is below the minimum system voltage level.	Engine may stop running or be difficult to start.
442 168 16	Battery 1 Voltage - Data valid but above normal operational range - Moderately severe level. ECM supply voltage is above the maximum system voltage level.	Possible electrical damage to all electrical components.
449 157 0	Injector metering rail 1 pressure - Data valid but above normal operational range - Most severe level.	None or possible engine noise associated with higher injection pressures (especially at idle or light load). Engine power is reduced.
451 157 3	Injector metering rail 1 pressure sensor circuit - Voltage above normal, or shorted to high source. High signal voltage detected at the rail fuel pressure sensor circuit.	Power and or speed derate.
452 157 4	Injector metering rail 1 pressure sensor circuit - Voltage below normal, or shorted to low source. Low signal voltage detected at the rail fuel pressure sensor circuit.	Power and or speed derate.
488 105 16	Intake manifold 1 temperature - Data valid but above normal operational range - Moderately severe level. Intake manifold air temperature signal indicates intake manifold air temperature is above the engine protection warning limit.	Progressive power derate increasing in severity from time of alert.
497 1377 2	Multiple unit synchronization switch - Data erratic, intermittent, or incorrect. Multiple unit synchronous ON/OFF switch and multiple unit synchronous complimentary ON/OFF switch have different values in the ECM.	Multiple unit synchronization feature is disabled.

※ Some fault codes are not applied to this machine.

Fault code J1939 SPN J1939 FMI	Reason	Effect (only when fault code is active)
515 3514 3	Sensor Supply 6 Circuit - Voltage Above Normal or Shorted to High Source. High voltage detected on the +5 volt sensor supply circuit to the fuel rail pressure sensor.	Engine power derate.
516 3514 4	Sensor Supply 6 Circuit - Voltage Below Normal or Shorted to Low Source. Low voltage detected on the +5 volt sensor supply circuit to the fuel rail pressure sensor.	Engine power derate.
523 611 2	Auxiliary intermediate (PTO) speed switch validation - Data erratic, intermittent, or incorrect. The position of the intermediate speed control switch 1 does not match the position of the intermediate speed control validation switch.	Intermediate speed control switch may not operate correctly.
527 702 3	Auxiliary input/output 2 circuit - Voltage above normal, or shorted to high source. High signal voltage or open circuit has been detected at the auxiliary input/output 2 circuit.	None on performance.
528 93 2	Auxiliary alternate torque validation switch - Data erratic, intermittent, or incorrect. An error has been detected in the alternate torque switch circuit.	Torque curve setting defaults to default curve.
529 703 3	Auxiliary input/output 3 circuit - Voltage above normal, or shorted to high source. High signal voltage has been detected at the auxiliary input/output 3 circuit.	None on performance.
553 157 16	Injector metering rail 1 pressure - Data valid but above normal operational range - Moderately severe level. The ECM has detected that fuel pressure is higher than commanded pressure.	None or possible engine noise associated with higher injection pressures (especially at idle or light load). Possible reduced engine performance.
554 157 2	Injector metering rail 1 pressure - Data erratic, Intermittent, or incorrect. The ECM has detected that the fuel pressure signal is not changing.	Possibly hard to start, low power, or engine smoke.
555 101 16	Crankcase Pressure - Data Valid but Above Normal Operational Range - Moderately Severe Level. The crankcase breather filter requires maintenance.	None on performance.
556 101 0	Crankcase Pressure - Data Valid but Above Normal Operational Range - Most Severe Level. The crankcase breather filter requires maintenance.	None on performance.
559 157 18	Injector metering rail 1 pressure - Data Valid but Below Normal Operational Range - Moderately Severe Level. The ECM has detected that fuel pressure is lower than commanded pressure.	Possibly hard to start or low power. Engine could possibly not start.

※ Some fault codes are not applied to this machine.

Fault code J1939 SPN J1939 FMI	Reason	Effect (only when fault code is active)
584 677 3	Starter relay driver circuit - Voltage above normal, or shorted to high source. Open circuit or high voltage detected at starter lockout circuit.	Either the engine will not start or the engine will not have starter lockout protection. The engine will not have starter lockout protection.
585 677 4	Starter relay driver circuit - Voltage below normal, or shorted to low source. Low voltage detected at starter lockout circuit.	The engine will not have starter lockout protection.
595 103 0	Turbocharger 1 Speed - Data Valid But Above Normal Operating Range - Moderately Severe Level. High turbocharger speed has been detected by the ECM.	Engine power derate. The ECM uses an estimated turbocharger speed.
596 167 16	Electrical Charging System Voltage - Data Valid But Above Normal Operational Range - Moderately Severe Level. High battery voltage detected by the battery voltage monitor feature.	Amber warning lamp illuminated until high battery voltage condition is corrected.
597 167 18	Electrical Charging System Voltage - Data Valid But Below Normal Operational Range - Moderately Severe Level. Low battery voltage detected by the battery voltage monitor feature.	Amber lamp will light until low battery voltage condition is corrected.
598 167 1	Electrical Charging System Voltage - Data Valid But Below Normal Operational Range - Most Severe Level. Very low battery voltage detected by the battery voltage monitor feature.	Red lamp illuminated until very low battery voltage condition is corrected.
599 640 14	Auxiliary commanded dual output shutdown - Special instructions. The engine protection limit has been exceeded for the dual outputs calibrated limits.	Engine will shut down.
649 1378 31	Engine Oil Change Interval - Condition Exists. Change engine oil and filter.	Maintenance reminder only .
687 103 18	Turbocharger 1 speed - Data valid but below normal operational range - Moderately severe level. Low turbocharger speed detected by the ECM.	Engine power derate. The ECM uses an estimated turbocharger speed.
689 190 2	Engine crankshaft speed/position - Data erratic, intermittent, or incorrect. The ECM has detected an error in the engine speed signal.	Possible reduced engine performance.
691 1172 3	Turbocharger 1 compressor inlet temperature circuit - Voltage above normal, or shorted to high source. High signal voltage detected at turbocharger compressor inlet air temperature circuit.	Engine power derate.
692 1172 4	Turbocharger 1 compressor inlet temperature circuit - Voltage below normal, or shorted to low source. Low signal voltage detected at turbocharger compressor inlet air temperature circuit.	Engine power derate.

※ Some fault codes are not applied to this machine.

Fault code J1939 SPN J1939 FMI	Reason	Effect (only when fault code is active)
697 1136 3	Engine ECU Temperature Sensor Circuit - Voltage Above normal, or Shorted to High source. High signal voltage or open circuit detected at the internal ECM temperature sensor.	None on performance.
698 1136 4	Engine ECU Temperature Sensor Circuit - Voltage Below Normal, or Shorted to Low Source. Low signal voltage detected at the internal ECM temperature sensor.	None on performance.
731 723 7	Engine speed / position camshaft and crankshaft misalignment - Mechanical system not responding properly or out of adjustment. Engine position signal from the crankshaft position sensor and camshaft position sensor do not match.	Excessive smoke, hard start, and rough idle possible. Possible reduced engine performance.
778 723 2	Engine camshaft speed / position sensor - Data erratic, intermittent, or incorrect. The ECM has detected an error in the camshaft position sensor signal.	Possible reduced engine performance and/or reduced starting capability. Engine runs using primary engine position sensor.
779 703 11	Auxiliary equipment sensor input 3 - Root cause not known.	Possible engine derate.
1117 627 2	Power supply lost with ignition on - Data erratic, intermittent, or incorrect. Supply voltage to the ECM fell below 6.2 volts momentarily, or the ECM was not allowed to power down correctly (retain battery voltage for 30 seconds after key OFF).	Possible no noticeable performance effects or engine dying or hard starting. Fault code information, trip information, and maintenance monitor data can be inaccurate.
1239 2623 3	Accelerator Pedal or Lever Position Sensor 2 Circuit - Voltage Above Normal or Shorted to High Source. High voltage detected at accelerator pedal position number 2 signal circuit.	Severe derate in power output of the engine. Limp home power only.
1241 2623 4	Accelerator Pedal or Lever Position Sensor 2 Circuit - Voltage Below Normal or Shorted to Low Source. Low voltage detected at accelerator pedal position number 2 signal circuit.	Severe derate in the power output of the engine. Limp home power only.
1242 91 2	Accelerator Pedal or Lever Position Sensor 1 and 2 - Data Erratic, Intermittent, or Incorrect. Accelerator position sensor number 1 and number 2 are reading different values.	The engine will only idle.
1515 91 19	SAE J1939 Multiplexed Accelerator Pedal or Lever Sensor System - Received Network Data In Error. The J1939 multiplexing controller has indicated a malfunction of the multiplexed accelerator pedal.	The engine will only idle.

※ Some fault codes are not applied to this machine.

Fault code J1939 SPN J1939 FMI	Reason	Effect (only when fault code is active)
1604 4796 31	Aftertreatment Diesel Oxidation Catalyst Missing - Condition Exists. The aftertreatment diesel oxidation catalyst is not present in the exhaust system.	Active aftertreatment diesel particulate filter regeneration will be disabled.
1633 625 2	OEM datalink cannot transmit - Data erratic, intermittent, or incorrect. Communications within the OEM datalink network is intermittent.	Engine will only idle.
1691 100 18	Aftertreatment Diesel Oxidation Catalyst Conversion Efficiency - Data Valid But Below Normal Operating Range - Moderately Severe Level. The temperature increase across the aftertreatment catalyst is lower than expected.	Active aftertreatment diesel particulate filter regeneration will be disabled.
1695 3513 3	Sensor Supply 5 - Voltage Above Normal or Shorted to High Source. High voltage detected at sensor supply 5 circuit in the OEM harness.	Severe derate in power output of the engine. Limp home power only.
1696 3513 4	Sensor Supply 5 - Voltage Below Normal or Shorted to Low Source. Low voltage detected at sensor supply number 5 circuit in the OEM harness.	Severe derate in power output of the engine. Limp home power only. Power Generation Engines : EGR valve actuation will be disabled. Active and stationary regeneration will be disabled.
1843 101 3	Crankcase Pressure Circuit - Voltage Above Normal or Shorted to High Source. High signal voltage detected at the crankcase pressure circuit.	None on performance.
1844 101 4	Crankcase Pressure Circuit - Voltage Below Normal or Shorted to Low Source. Low signal voltage detected at the crankcase pressure circuit.	None on performance.
1852 97 16	Water-in-Fuel Indicator - Data Valid But Above Normal Operating Range - Moderately Severe Level. The water-in-fuel Indicator indicates that the water level is above warning level.	None on performance.
1866 411 2	Exhaust Gas Recirculation Valve Delta Pressure - Data Erratic, Intermittent, or Incorrect. An error in the EGR delta pressure signal was detected at initial key ON or the sensor failed the autozero test.	EGR valve actuation will be disabled.
1879 3251 3	Aftertreatment Diesel Particulate Filter Differential Pressure Sensor Circuit - Voltage Above Normal or Shorted to High Source. High signal voltage detected at the aftertreatment differential pressure sensor circuit.	Active and stationary regeneration of the diesel particulate filter will be disabled.
1881 3251 4	Aftertreatment Diesel Particulate Filter Differential Pressure Sensor Circuit - Voltage Below Normal or Shorted to Low Source. Low signal voltage or open circuit detected at the aftertreatment differential pressure sensor circuit.	Active and stationary regeneration of the diesel particulate filter will be disabled.

※ Some fault codes are not applied to this machine.

Fault code J1939 SPN J1939 FMI	Reason	Effect (only when fault code is active)
1883 3251 2	Aftertreatment Diesel Particulate Filter Differential Pressure Sensor - Data Erratic, Intermittent, or Incorrect. The aftertreatment diesel particulate filter differential pressure sensor is reading an erratic value at initial key ON or during engine operation.	Active and stationary regeneration of the diesel particulate filter will be disabled.
1896 2791 13	EGR Valve Controller - Out of Calibration. The EGR valve has failed the automatic calibration procedure at initial key ON.	EGR valve actuation will be disabled.
1898 641 13	VGT Actuator Controller - Out of Calibration. The VGT has failed the automatic calibration procedure at initial key ON.	Low intake manifold pressure. The VGT will be in the open position.
1911 157 0	Injector Metering Rail Number 1 Pressure - Data Valid But Above Normal Operational Range - Most Severe Level. The ECM has detected that fuel pressure in the rail fuel was higher than the commanded pressure.	None, or possible engine noise associated with higher injection pressures (especially at idle or light load) or possible power interruption associated with high-pressure relief valve reset.
1921 3251 0	Aftertreatment Diesel Particulate Filter Differential Pressure - Data Valid But Above Normal Operating Range - Moderately Severe Level. The soot load of the aftertreatment diesel particulate filter has exceeded the recommended limits.	The aftertreatment dash lamp will flash. Engine protection derate.
1922 3251 0	Aftertreatment Diesel Particulate Filter Differential Pressure - Data Valid But Above Normal Operating Range - Most Severe Level. The soot load of the aftertreatment diesel particulate filter has exceeded the recommended limits. Engine protection derate is enabled.	Severe engine derate.
1938 3597 1	ECU Power Output Supply Voltage 1-Data Valid But Below Normal Operational Range - Moderately Severe Level. Low battery voltage detected by the VGT actuator.	None on performance.
1942 101 2	Crankcase Pressure - Data Erratic, Intermittent, or Incorrect. The ECM has detected that the crankcase pressure signal is reading an erratic value at initial key ON or during engine operation.	None on performance.
1961 2791 0	EGR Valve Control Circuit Calculated Over Temperature - Data Valid But Above Normal Operational Range - Least Severe Level. High EGR valve driver temperature has been detected.	EGR valve operation will be disabled.
1962 641 0	VGT Actuator Driver Over Temperature (Calculated) - Data Valid But Above Normal Operating Range - Least Severe Level. High internal VGT actuator temperature has been detected.	None on performance.

※ Some fault codes are not applied to this machine.

Fault code J1939 SPN J1939 FMI	Reason	Effect (only when fault code is active)
1963 3482 7	Aftertreatment Fuel Shutoff Valve 1-Mechanical System Not Responding or Out of Adjustment. The aftertreatment fuel shutoff valve has been detected to be stuck closed.	Active aftertreatment diesel particulate filter regeneration will be disabled until the next key cycle.
1992 190 0	Engine Crankshaft Speed/Position - Data Valid But Above Normal Operating Range - Moderately Severe Level. Engine crankshaft speed/position signal indicates engine speed above engine protection limit.	Engine shutdown.
1993 4795 31	Aftertreatment Diesel Particulate Filter Missing - Condition Exists. The aftertreatment diesel particulate filter in the exhaust system is not present.	Active aftertreatment diesel particulate filter regeneration will be disabled.
2182 1072 3	Engine Brake Actuator Driver 1 Circuit - Voltage Above Normal or Shorted to High Source. High voltage or an open circuit detected at the engine brake solenoid number 1 signal circuit.	Engine brake on cylinders 1, 2, and 3 can not be activated.
2183 1072 4	Engine Brake Actuator Driver 1 Circuit - Voltage Below Normal or Shorted to Low Source. Low voltage detected at the engine brake solenoid number 1 signal circuit.	Engine brake on cylinders 1, 2, and 3 can not be activated.
2185 3512 3	Sensor supply 4 circuit - Voltage above normal, or shorted to high source. High voltage detected at 5 VDC sensor supply circuit to the accelerator pedal position sensor.	Engine will only idle.
2186 3512 4	Sensor supply 4 circuit - Voltage below normal, or shorted to low source. Low voltage detected at 5 VDC sensor supply circuit to the accelerator pedal position sensor.	Engine will only idle.
2195 703 14	Auxiliary Equipment Sensor Input Engine Protection Critical - Special Instructions. The emergency door of the vehicle has been detected open.	Engine will derate or shut down, depending on the engine protection settings.
2198 641 11	VGT Actuator Driver Circuit - Root Cause Not Known. Intermittent communication between the smart VGT controller and the ECM has been detected. The VGT controller is not interpreting the J1939 message from the ECM correctly.	VGT actuation will be disabled.
2265 1075 3	Electric lift pump for engine fuel supply circuit - Voltage above normal, or shorted to high source. High voltage or open detected at the fuel lift pump signal circuit.	Engine may be difficult to start.
2266 1075 4	Electric lift pump for engine fuel supply circuit - Voltage below normal, or shorted to low source. Low signal voltage detected at the fuel lift pump circuit.	Engine can be difficult to start.
2272 27 4	EGR Valve Position Circuit - Voltage Below Normal or Shorted to Low Source. Low signal voltage has been detected at the EGR valve position sensor circuit	EGR valve actuation will be disabled.

※ Some fault codes are not applied to this machine.

Fault code J1939 SPN J1939 FMI	Reason	Effect (only when fault code is active)
2273 411 3	Exhaust Gas Recirculation Valve Delta Pressure Sensor Circuit - Voltage Above Normal or Shorted to High Source. High signal voltage detected at the EGR differential pressure sensor circuit.	EGR valve actuation will be disabled.
2274 411 4	Exhaust Gas Recirculation Valve Delta Pressure Sensor Circuit - Voltage Below Normal or Shorted to Low Source. Low signal voltage detected at the EGR differential pressure sensor circuit.	EGR valve actuation will be disabled.
2288 103 15	Turbocharger 1 Speed - Data Valid But Above Normal Operating Range - Least Severe Level. High turbocharger speed has been detected by the ECM.	Engine power derate to lower the turbocharger speed.
2311 633 31	Electronic fuel injection control valve circuit - Condition exists. Fuel pump actuator circuit resistance too high or too low, or an intermittent connection has been detected.	Engine will run rough with low power.
2321 190 2	Engine crankshaft speed/position - Data erratic, intermittent, or incorrect. crankshaft engine speed sensor intermittent synchronization.	The engine can exhibit misfire as control switches from the primary to the backup speed sensor. Engine power is reduced while the engine operates on the backup speed sensor.
2322 723 2	Engine camshaft speed / position sensor - Data erratic, intermittent, or incorrect. Camshaft engine speed sensor intermittent synchronization.	None on performance.
2347 2629 15	Turbocharger Compressor Outlet Temperature (Calculated) - Data Valid But Above Normal Operating Range - Least Severe Level. High turbocharger compressor outlet air temperature has been calculated by the electronic control module (ECM).	Fuel is limited in an attempt to decrease the calculated turbocharger compressor outlet air temperature.
2349 2791 5	EGR Valve Control Circuit - Current Below Normal or Open Circuit. Motor terminal or motor coil open circuit has been detected by the ECM.	EGR valve actuation will be disabled.
2353 2791 6	EGR Valve Control Circuit - Current Above Normal or Grounded Circuit. A short circuit to ground has been detected in the EGR valve motor circuit.	EGR valve actuation will be disabled.
2357 2791 7	EGR Valve Control Circuit - Mechanical System Not Responding or Out of Adjustment. The EGR valve motor has exceeded the duty cycle limit, indicating a stuck open EGR valve.	EGR valve actuation will be disabled.
2363 1073 4	Engine Brake Actuator Driver Output 2 Circuit - Voltage Below Normal or Shorted to Low Source. Low voltage detected at the engine brake solenoid number 2 signal circuit.	Engine brake on cylinders 4, 5, and 6 can not be activated.

※ Some fault codes are not applied to this machine.

Fault code J1939 SPN J1939 FMI	Reason	Effect (only when fault code is active)
2367 1073 3	Engine Brake Actuator Driver Output 2 Circuit - Voltage Above Normal or Shorted to High Source. Open circuit or high voltage detected at the engine brake solenoid number 2 signal circuit.	Engine brake on cylinders 4, 5, and 6 can not be activated.
2372 95 16	Fuel Filter Differential Pressure - Data Valid But Above Normal Operational Range - Moderately Severe Level. Excessive fuel flow restriction to the high pressure fuel pump has been detected.	Engine can possibly have low power.
2373 1209 3	Exhaust Gas Pressure Sensor Circuit - Voltage Above Normal or Shorted to High Source. High signal voltage detected at the exhaust gas pressure circuit.	None on performance.
2374 1209 4	Exhaust Gas Pressure Sensor Circuit - Voltage Below Normal or Shorted to Low Source. Low signal voltage detected at the exhaust gas pressure circuit.	None on performance.
2375 412 3	Exhaust Gas Recirculation Temperature Sensor Circuit - Voltage Above Normal or Shorted to High Source. High signal voltage detected at EGR temperature circuit.	EGR valve actuation will be disabled.
2376 412 4	Exhaust Gas Recirculation Temperature Sensor Circuit - Voltage Below Normal or Shorted to Low Source. Low signal voltage detected at EGR temperature circuit.	EGR valve actuation will be disabled.
2377 647 3	Fan control circuit - Voltage above normal, or shorted to high source. Open circuit or high voltage detected at the fan control circuit.	The fan can stay on continuously or not run at all.
2387 641 7	VGT Actuator Driver Circuit (Motor) - Mechanical System Not Responding or Out of Adjustment. The smart VGT controller has detected incorrect stop limits, or the VGT is unable to move to the closed position.	VGT travel may be limited.
2448 111 17	Coolant Level - Data Valid But Below Normal Operational Range - Least Severe Level. Low engine coolant level detected.	None on performance.
2449 641 13	VGT Actuator Controller - Out of Calibration. The VGT actuator has been installed incorrectly.	VGT actuation will be disabled.
2554 1209 2	Exhaust Gas Pressure - Data Erratic, Intermittent or Incorrect. The exhaust gas pressure sensor is reading an erratic value.	The ECM will estimate the exhaust gas pressure.
2555 729 3	Intake air heater 1 circuit - Voltage above normal, or shorted to high source. High voltage detected at the intake air heater signal circuit.	The intake air heaters may be ON or OFF all the time.
2556 729 4	Intake air heater 1 circuit - Voltage below normal, or shorted to low source. Low voltage detected at the intake air heater signal circuit.	The intake air heaters may be ON or OFF all the time.

※ Some fault codes are not applied to this machine.

Fault code J1939 SPN J1939 FMI	Reason	Effect (only when fault code is active)
2557 697 3	Auxiliary PWM driver 1 circuit - Voltage above normal, or shorted to high source. High signal voltage detected at the analog torque circuit.	Can not control transmission.
2558 697 4	Auxiliary PWM driver 1 circuit - Voltage below normal, or shorted to low source. Low signal voltage detected at the analog torque circuit.	Can not control transmission.
2634 641 12	VGT Actuator Controller - Bad Intelligent Device or Component. An internal error has been detected by the smart VGT controller.	VGT actuation will be disabled.
2635 641 31	VGT Actuator Driver Circuit - Condition Exists. A calibration mismatch between the VGT actuator and the ECM has been detected.	VGT actuation will be disabled.
2636 641 9	VGT Actuator Driver Circuit - Abnormal Update Rate. No communications on the J1939 data link between the engine ECM and the smart VGT controller.	The VGT will move to the default open position.
2637 5018 11	Aftertreatment Diesel Oxidation Catalyst Face Plugged - Root Cause Not Known. The front face of the aftertreatment diesel oxidation catalyst has been detected to be plugged with soot.	Active aftertreatment diesel particulate filter regeneration will be disabled.
2639 3251 15	Aftertreatment Diesel Particulate Filter Differential Pressure - Data Valid But Above Normal Operating Range - Least Severe Level. The soot load of the aftertreatment diesel particulate filter has exceeded the recommended limits.	The aftertreatment diesel particulate filter lamp will be illuminated and will begin to flash as the severity of the soot load increases. Possible engine protection derate based on severity.
2732 4097 3	Aftertreatment Fuel Drain Valve Circuit - Voltage Above Normal or Shorted to High Source. High signal voltage detected at the aftertreatment fuel drain valve circuit.	Active aftertreatment diesel particulate filter regeneration will be disabled.
2733 4097 4	Aftertreatment Fuel Drain Valve Circuit - Voltage Below Normal or Shorted to Low Source. Low signal voltage detected at the aftertreatment fuel drain valve circuit.	Active aftertreatment diesel particulate filter regeneration will be disabled.
2741 3482 31	Aftertreatment Fuel Shutoff Valve 1 Swapped - Condition Exists. Aftertreatment fuel shutoff valve 1 and aftertreatment fuel drain valve wiring harness connections are reversed.	Active aftertreatment diesel particulate filter regeneration will be disabled.
2754 81 16	Engine Diesel Particulate Filter Intake Pressure - Data Valid But Above Normal Operating Range - Moderately Severe Level. Excessive black smoke has been detected exiting the engine and entering the aftertreatment diesel particulate filter.	None on performance
2764 1209 16	Exhaust Gas Pressure - Data Valid but Above Normal Operating Range - Moderately Severe Level. High exhaust gas pressure has been detected by the exhaust gas pressure sensor.	Fueling derate to bring exhaust gas pressure below the maximum operating limits.

※ Some fault codes are not applied to this machine.

Fault code J1939 SPN J1939 FMI	Reason	Effect (only when fault code is active)
2765 2797 13	Engine Injector Bank 1 Barcodes - Out of Calibration. Invalid injector barcode information has been entered, or has not been entered at all.	None on performance.
2777 3703 31	Particulate Trap Active Regeneration Inhibited Due to Inhibit Switch - Condition Exists. Regeneration of the diesel particulate filter has been prevented due to the permit switch being disabled.	None on performance.
2878 4097 7	Aftertreatment Fuel Drain Valve - Mechanical System Not Responding Properly or Out of Adjustment. The aftertreatment fuel shutoff drain valve has been detected to be stuck closed.	Active aftertreatment diesel particulate filter regeneration will be disabled.
2961 412 15	Exhaust Gas Recirculation Temperature - Data Valid But Above Normal Operational Range - Least Severe Level. EGR temperature has exceeded the engine protection limit.	Slight fueling derate to bring EGR temperature under the maximum limit.
2962 412 16	Exhaust Gas Recirculation Temperature - Data Valid But Above Normal Operational Range - Moderately Severe Level. EGR temperature has exceeded the engine protection limit.	Severe fueling derate to bring EGR temperature under the maximum limit.
2973 102 2	Intake manifold 1 pressure - Data erratic, intermittent, or incorrect. The intake manifold pressure sensor is reading an erratic value.	The ECM will estimate the intake manifold pressure. Possible engine power derate.
3133 3610 3	Aftertreatment Diesel Particulate Filter Outlet Pressure Sensor Circuit - Voltage Above Normal, or Shorted to High Source. High signal voltage detected at the aftertreatment diesel particulate filter outlet pressure sensor circuit.	Active and stationary regeneration of the diesel particulate filter will be disabled.
3134 3610 4	Aftertreatment Diesel Particulate Filter Outlet Pressure Sensor Circuit - Voltage Below Normal, or Shorted to Low Source. Low signal voltage detected at the aftertreatment diesel particulate filter outlet pressure sensor circuit.	Active and stationary regeneration of the diesel particulate filter will be disabled.
3135 3610 2	Aftertreatment Diesel Particulate Filter Outlet Pressure - Data Erratic, Intermittent or Incorrect. The aftertreatment diesel particulate filter outlet pressure sensor is reading an erratic value at initial key ON or during engine operation.	Active and stationary regeneration of the diesel particulate filter will be disabled.
3139 3667 3	Engine Air Shutoff Circuit - Voltage Above Normal or Shorted to High Source. High signal voltage detected at the air shutoff circuit.	The engine air shutoff valve will be disabled.
3186 1623 9	Tachograph Output Shaft Speed - Abnormal Update Rate. No communication or an invalid data transfer rate has been detected on the J1939 data link between the ECM and the tachograph output shaft speed sensor.	None on performance.

※ Some fault codes are not applied to this machine.

Fault code J1939 SPN J1939 FMI	Reason	Effect (only when fault code is active)
3213 1623 19	Tachograph Output Shaft Speed - Received Network Data In Error. The J1939 multiplexing controller has indicated a malfunction of the tachograph output shaft speed sensor.	None on performance.
3245 3936 7	Aftertreatment Diesel Particulate Filter System - Mechanical System Not Responding or Out of Adjustment. The aftertreatment diesel particulate filter has been damaged.	Active aftertreatment diesel particulate filter regeneration will be disabled.
3251 475 16	Aftertreatment Diesel Oxidation Catalyst Intake Temperature - Data Valid But Above Normal Operating Range - Moderately Severe Level. The diesel oxidation catalyst intake temperature sensor reading has exceeded the maximum temperature limit.	Active aftertreatment diesel particulate filter regeneration will be disabled.
3253 3242 16	Aftertreatment Diesel Particulate Filter Intake Temperature - Data Valid But Above Normal Operating Range - Moderately Severe Level. The aftertreatment diesel particulate filter intake temperature sensor reading has exceeded the maximum engine protection temperature limit.	Active and stationary aftertreatment diesel particulate filter regeneration will be disabled.
3254 3242 15	Aftertreatment Diesel Particulate Filter Intake Temperature - Data Valid But Above Normal Operating Range - Least Severe Level. The aftertreatment diesel particulate filter intake temperature sensor reading has exceeded the maximum engine protection temperature limit.	Active and stationary aftertreatment diesel particulate filter regeneration will be disabled.
3255 3246 16	Aftertreatment Diesel Particulate Filter Outlet Temperature - Data Valid But Above Normal Operating Range - Moderately Severe Level. The aftertreatment diesel particulate filter outlet temperature sensor reading has exceeded the maximum engine protection temperature limit.	Active and stationary aftertreatment diesel particulate filter regeneration will be disabled.
3256 3246 15	Aftertreatment Diesel Particulate Filter Outlet Temperature - Data Valid But Above Normal Operating Range - Least Severe Level. The aftertreatment diesel particulate filter outlet temperature sensor reading has exceeded the maximum engine protection temperature limit.	Active and stationary aftertreatment diesel particulate filter regeneration will be disabled.
3311 3242 0	Aftertreatment Diesel Particulate Filter Intake Temperature - Data Valid But Above Normal Operating Range - Most Severe Level. The aftertreatment diesel particulate filter intake temperature sensor reading has exceeded the maximum engine protection temperature limit.	Active aftertreatment diesel particulate filter regeneration will be disabled.
3312 3246 0	Aftertreatment Diesel Particulate Filter Outlet Temperature - Data Valid but Above Normal Operating Range - Most Severe Level. The aftertreatment diesel particulate filter outlet temperature sensor reading has exceeded the maximum engine protection temperature limit.	The exhaust gas recirculation (EGR) valve operation will be disabled. Active aftertreatment diesel particulate filter regeneration will be disabled.

※ Some fault codes are not applied to this machine.

Fault code J1939 SPN J1939 FMI	Reason	Effect (only when fault code is active)
3313 4765 4	Aftertreatment Diesel Oxidation Catalyst Intake Temperature Sensor Circuit - Voltage Below Normal or Shorted to Low Source. Low signal voltage detected at the catalyst intake sensor circuit.	Active aftertreatment diesel particulate filter regeneration will be disabled.
3314 4765 3	Aftertreatment Diesel Oxidation Catalyst Intake Temperature Sensor Circuit - Voltage Above Normal or Shorted to High Source. High signal voltage detected at the catalyst intake temperature sensor circuit.	Active aftertreatment diesel particulate filter regeneration will be disabled.
3315 4765 2	Aftertreatment Diesel Oxidation Catalyst Intake Temperature - Data Erratic, Intermittent, or Incorrect. The aftertreatment diesel oxidation catalyst intake temperature sensor is not changing with engine operating conditions.	Active aftertreatment diesel particulate filter regeneration will be disabled. EGR valve operation will be disabled.
3316 3242 4	Aftertreatment Diesel Particulate Filter Intake Temperature Sensor Circuit - Voltage Below Normal or Shorted to Low Source. Low signal voltage detected at the aftertreatment diesel particulate filter intake temperature sensor circuit.	The exhaust gas recirculation (EGR) valve operation will be disabled. Active aftertreatment diesel particulate filter regeneration will be disabled.
3317 3242 3	Aftertreatment Diesel Particulate Filter Intake Temperature Sensor Circuit - Voltage Above Normal or Shorted to High Source. High signal voltage or open circuit detected at the aftertreatment diesel particulate filter intake temperature sensor circuit.	The exhaust gas recirculation (EGR) valve operation will be disabled. Active aftertreatment diesel particulate filter regeneration will be disabled.
3318 3242 2	Aftertreatment Diesel Particulate Filter Intake Temperature - Data Erratic, Intermittent, or Incorrect. The aftertreatment diesel particulate filter intake temperature is not changing with engine operating conditions.	EGR valve operation will be disabled. Active aftertreatment diesel particulate filter regeneration will be disabled.
3319 3246 3	Aftertreatment Diesel Particulate Filter Outlet Temperature Sensor Circuit - Voltage Above Normal or Shorted to High Source. High signal voltage or open circuit detected at the aftertreatment diesel particulate filter outlet temperature sensor circuit.	EGR valve operation will be disabled. Active aftertreatment diesel particulate filter regeneration will be disabled.
3321 3246 4	Aftertreatment Diesel Particulate Filter Outlet Temperature Sensor Circuit - Voltage Below Normal or Shorted to Low Source. Low signal voltage detected at the aftertreatment diesel particulate filter outlet temperature sensor circuit.	EGR valve operation will be disabled. Active aftertreatment diesel particulate filter regeneration will be disabled.
3322 3246 2	Aftertreatment Diesel Particulate Filter Outlet Temperature - Data Erratic, Intermittent, or Incorrect. The aftertreatment diesel particulate filter outlet temperature is not changing with engine operating conditions.	EGR valve operation will be disabled. Active aftertreatment diesel particulate filter regeneration will be disabled.

※ Some fault codes are not applied to this machine.

Fault code J1939 SPN J1939 FMI	Reason	Effect (only when fault code is active)
3326 91 9	SAE J1939 Multiplexed Accelerator Pedal or Lever Sensor System - Abnormal Update Rate. The ECM expected information from a multiplexed accelerator pedal or lever sensor but did not receive it soon enough or did not receive it at all.	Engine will only idle.
3328 191 9	Transmission Output Shaft Speed - Abnormal Update Rate. No communication or an invalid data transfer rate has been detected on the J1939 data link between the ECM and the transmission output shaft speed sensor.	None on performance.
3418 191 19	Transmission Output Shaft Speed - Received Network Data In Error. The J1939 multiplexing controller has indicated a malfunction of the transmission output shaft speed sensor.	None on performance.
3525 84 19	Wheel-Based Vehicle Speed - Received Network Data In Error. The J1939 multiplexing controller has indicated a malfunction of the wheel-based vehicle speed sensor.	None on performance.
3526 84 9	Wheel-Based Vehicle Speed - Abnormal Update Rate. No communication or an invalid data transfer rate has been detected on the J1939 data link between the ECM and the wheel-based vehicle speed sensor.	None on performance.
3527 558 19	Accelerator Pedal or Lever Idle Validation Switch - Received Network Data In Error. The J1939 multiplexing controller has indicated a malfunction of the accelerator pedal or lever idle validation switch.	The engine will only idle.
3528 558 9	Accelerator Pedal or Lever Idle Validation Switch - Abnormal Update Rate. No communication or an invalid data transfer rate has been detected on the J1939 data link between the ECM and the accelerator pedal or lever idle validation switch.	Engine will only idle.
3616 2633 7	Engine VGT Nozzle Position - Mechanical System Not Responding or Out of Adjustment. The smart VGT controller has detected incorrect stop limits or the VGT is unable to move to the closed position.	VGT travel may be limited.
3697 630 12	Engine Control Module Calibration Memory - Bad Intelligent Device or Component. Error internal to the ECM related to engine software failures.	Engine may not start.
3724 168 17	Battery 1 Voltage - Data Valid But Below Normal Operating Range - Least Severe Level. Low voltage to the EGR valve device driver has been detected.	EGR valve actuation will be disabled.

※ Some fault codes are not applied to this machine.

Fault code J1939 SPN J1939 FMI	Reason	Effect (only when fault code is active)
3727 5571 7	High Pressure Common Rail Fuel Pressure Relief Valve - Mechanical System Not Responding or Out of Adjustment. The fuel rail high-pressure relief valve has opened at a lower than expected pressure.	Possible low power or power interruption associated with relief valve reset.
3737 1675 31	Engine Starter Mode Overcrank Protection - Condition Exists. The starter motor has been temporarily disabled in order to prevent starter damage.	Starter operation is prohibited until the starter motor has adequately cooled.
3741 5571 0	Injector Metering Rail Number 1 Pressure - Data Valid But Above Normal Operating Range - Most Severe Level. The ECM has detected fuel pressure in the rail fuel was higher than the commanded pressure.	Possible engine noise associated with higher injection pressures (especially at idle or light load) or possible power interruption associated with high-pressure relief valve reset.
3765 441 3	Auxiliary Temperature Sensor Input 1 - Voltage Above Normal or Shorted to High Source. High signal voltage or open circuit detected at the OEM auxiliary temperature circuit.	None on performance.
3766 441 4	Auxiliary Temperature Sensor Input 1 Circuit - Voltage Below Normal or Shorted to Low Source. Low signal voltage detected at the OEM auxiliary temperature circuit.	None on performance.

※ Some fault codes are not applied to this machine.

3) DEFINITION OF OPERATING MODES

(1) Normal

There's no failure detected in the transmission system or the failure has no or slight effects on transmission control. TCU will work without or in special cases with little limitations. (See following table)

(2) Substitute clutch control

TCU can't change the gears or the direction under the control of the normal clutch modulation. TCU uses the substitute strategy for clutch control. All modulations are only time controlled. (Comparable with EST 25)

(3) Limp-home

The detected failure in the system has strong limitations to transmission control. TCU can engage only one gear in each direction. In some cases only one direction will be possible. TCU will shift the transmission into neutral at the first occurrence of the failure. First, the operator must shift the gear selector into neutral position.

If output speed is less than a threshold for neutral to gear and the operator shifts the gear selector into forward or reverse, the TCU will select the limp-home gear.

If output speed is less than a threshold for reversal speed and TCU has changed into the limp-home gear and the operator selects a shuttle shift, TCU will shift immediately into the limp-home gear of the selected direction.

If output speed is greater than the threshold, TCU will shift the transmission into neutral. The operator has to slow down the vehicle and must shift the gear selector into neutral position.

(4) Transmission-shutdown

TCU has detected a severe failure that disables control of the transmission.

TCU will shut off the solenoid valves for the clutches and also the common power supply (VPS1).

Transmission shifts to neutral. The park brake will operate normally, also the other functions which use ADM1 to ADM8.

The operator has to slow down the vehicle. The transmission will stay in neutral.

(5) TCU-shutdown

TCU has detected a severe failure that disables control of system.

TCU will shut off all solenoid valves and also both common power supplies (VPS1, VPS2). The park brake will engage, also functions are disabled which use ADM 1 to ADM 8.

The transmission will stay in neutral.

※ Abbreviations

OC : Open circuit

SC : Short circuit

OP mode : Operating mode

TCU : Transmission control unit

EEC : Electronic engine controller

PTO : Power take off

4) TRANSMISSION FAULT CODES

Fault code (Hex)	Meaning of the fault code possible reason for fault detection	Reaction of the TCU	Possible steps to repair
10	Logical error at direction select signal 3rd shift lever TCU detected a wrong signal combination for the direction ·Cable from shift lever 3 to TCU is broken ·Cable is defective and is contacted to battery voltage or vehicle ground ·Shift lever is defective	TCU shifts transmission to neutral if selector active OP mode : Transmission shutdown if selector active	<ul style="list-style-type: none"> · Check the cables from TCU to shift lever 3 · Check signal combinations of shift lever positions F-N-R · If shift lever is a CAN shift lever check CAN cable/shifter/device ※ Fault is cleared if TCU detects a valid neutral signal for the direction at the shift lever
11	Logical error at gear range signal TCU detected a wrong signal combination for the gear range ·Cable from shift lever to TCU is broken ·Cable is defective and is contacted to battery voltage or vehicle ground ·Shift lever is defective	TCU shifts transmission to neutral OP mode : Transmission shutdown	<ul style="list-style-type: none"> · Check the cables from TCU to shift lever · Check signal combinations of shift lever positions for gear range ※ Failure cannot be detected in systems with DW2/DW3 shift lever. Fault is taken back if TCU detects a valid signal for the position
12	Logical error at direction select signal TCU detected a wrong signal combination for the direction ·Cable from shift lever to TCU is broken ·Cable is defective and is contacted to battery voltage or vehicle ground ·Shift lever is defective	TCU shifts transmission to neutral OP mode : Transmission shutdown	<ul style="list-style-type: none"> · Check the cables from TCU to shift lever · Check signal combinations of shift lever positions F-N-R ※ Fault is taken back if TCU detects a valid signal for the direction at the shift lever
13	Logical error at engine derating device TCU detected no reaction of engine while derating device active	After selecting neutral, TCU change to OP mode limp home	<ul style="list-style-type: none"> · Check engine derating device ※ This fault is reset after power up of TCU
15	Logical error at direction select signal 2 shift lever TCU detected a wrong signal combination for the direction ·Cable from shift lever 2 to TCU is broken ·Cable is defective and is contacted to battery voltage or vehicle ground ·Shift lever is defective	TCU shifts transmission to neutral if selector active OP mode : Transmission shutdown if selector active	<ul style="list-style-type: none"> · Check the cables from TCU to shift lever 2 · Check signal combinations of shift lever positions F-N-R ※ Fault is taken back if TCU detects a valid neutral signal for the direction at the shift lever
17	S.C. to ground at customer specific function No. 1 (ride control) TCU detected a wrong voltage at the output pin, that looks like a S.C. to vehicle ground ·Cable is defective and is contacted to vehicle ground ·Customer specific function No. 1 device has an internal defect ·Connector pin is contacted to vehicle ground	Customer specific	<ul style="list-style-type: none"> · Check the cable from TCU to customer specific function No. 1 device · Check the connectors from customer specific function No. 1 to TCU · Check the resistance of customer specific function No. 1 device

※ Some fault codes are not applied to this machine.

Fault code (Hex)	Meaning of the fault code possible reason for fault detection	Reaction of the TCU	Possible steps to repair
18	S.C. to battery voltage at customer specific function No. 1 (ride control) TCU detected a wrong voltage at the output pin, that looks like a S.C. to battery voltage ·Cable is defective and is contacted to battery voltage ·Customer specific function No. 1 device has an internal defect ·Connector pin is contacted to battery voltage	Customer specific	<ul style="list-style-type: none"> · Check the cable from TCU to customer specific function No. 1 device · Check the connectors from customer specific function No. 1 to TCU · Check the resistance of customer specific function No. 1 device
19	O.C. at customer specific function No. 1 (ride control) TCU detected a wrong voltage at the output pin, that looks like a O.C. for this output pin ·Cable is defective and has no connection to TCU ·Customer specific function No. 1 device has an internal defect ·Connector has no connection to TCU	Customer specific	<ul style="list-style-type: none"> · Check the cable from TCU to customer specific function No. 1 device · Check the connectors from customer specific function No. 1 device to TCU · Check the resistance of customer specific function No. 1 device
21	S.C. to battery voltage at clutch cut off input The measured voltage is too high: ·Cable is defective and is contacted to battery voltage ·Clutch cut off sensor has an internal defect ·Connector pin is contacted to battery voltage	Clutch cut off function is disabled OP mode : Normal	<ul style="list-style-type: none"> · Check the cable from TCU to the sensor · Check the connectors · Check the clutch cut off sensor
22	S.C. to ground or O.C. at clutch cut off input The measured voltage is too low: ·Cable is defective and is contacted to vehicle ground ·Cable has no connection to TCU ·Clutch cut off sensor has an internal defect ·Connector pin is contacted to vehicle ground or is broken	Clutch cut off function is disabled OP mode : Normal	<ul style="list-style-type: none"> · Check the cable from TCU to the sensor · Check the connectors · Check the clutch cut off sensor
25	S.C. to battery voltage or O.C. at transmission sump temperature sensor input The measured voltage is too high: ·Cable is defective and is contacted to battery voltage ·Cable has no connection to TCU ·Temperature sensor has an internal defect ·Connector pin is contacted to battery voltage or is broken	No reaction, TCU use default temperature OP mode : Normal	<ul style="list-style-type: none"> · Check the cable from TCU to the sensor · Check the connectors · Check the temperature sensor

※ Some fault codes are not applied to this machine.

Fault code (Hex)	Meaning of the fault code possible reason for fault detection	Reaction of the TCU	Possible steps to repair
26	S.C. to battery voltage or O.C. at transmission sump temperature sensor input The measured voltage is too low: ·Cable is defective and is contacted to vehicle ground ·Temperature sensor has an internal defect ·Connector pin is contacted to vehicle ground	No reaction, TCU uses default temperature OP mode : Normal	<ul style="list-style-type: none"> · Check the cable from TCU to the sensor · Check the connectors · Check the temperature sensor
27	S.C. to battery voltage or O.C. at retarder temperature sensor input The measured voltage is too high: ·Cable is defective and is contacted to battery voltage ·Cable has no connection to TCU ·Temperature sensor has an internal defect ·Connector pin is contacted to battery voltage or is broken	No reaction, TCU uses default temperature OP mode : Normal	<ul style="list-style-type: none"> · Check the cable from TCU to the sensor · Check the connectors · Check the temperature sensor
28	S.C. to ground at retarder temperature sensor input The measured voltage is too low: ·Cable is defective and is contacted to vehicle ground ·Temperature sensor has an internal defect ·Connector pin is contacted to vehicle ground	No reaction, TCU uses default temperature OP mode : Normal	<ul style="list-style-type: none"> · Check the cable from TCU to the sensor · Check the connectors · Check the temperature sensor
31	S.C. to battery voltage or O.C. at engine speed input TCU measures a voltage higher than 7.00V at speed input pin ·Cable is defective and is contacted to battery voltage ·Cable has no connection to TCU ·Speed sensor has an internal defect ·Connector pin is contacted to battery voltage or has no contact	OP mode : Substitute clutch control	<ul style="list-style-type: none"> · Check the cable from TCU to the sensor · Check the connectors · Check the speed sensor
32	S.C. to ground at engine speed input TCU measures a voltage less than 0.45V at speed input pin ·Cable/connector is defective and is contacted to vehicle ground ·Speed sensor has an internal defect	OP mode : Substitute clutch control	<ul style="list-style-type: none"> · Check the cable from TCU to the sensor · Check the connectors · Check the speed sensor
33	Logical error at engine speed input TCU measures a engine speed over a threshold and the next moment the measured speed is zero ·Cable/connector is defective and has bad contact ·Speed sensor has an internal defect ·Sensor gap has the wrong size	OP mode : Substitute clutch control	<ul style="list-style-type: none"> · Check the cable from TCU to the sensor · Check the connectors · Check the speed sensor · Check the sensor gap <p>※ This fault is reset after power up of TCU</p>

※ Some fault codes are not applied to this machine.

Fault code (Hex)	Meaning of the fault code possible reason for fault detection	Reaction of the TCU	Possible steps to repair
34	S.C. to battery voltage or O.C. at turbine speed input TCU measures a voltage higher than 7.00V at speed input pin ·Cable is defective and is contacted to vehicle battery voltage ·Cable has no connection to TCU ·Speed sensor has an internal defect ·Connector pin is contacted to battery voltage or has no contact	OP mode : Substitute clutch control If a failure is existing at output speed, TCU shifts to neutral OP mode : Limp home	<ul style="list-style-type: none"> · Check the cable from TCU to the sensor · Check the connectors · Check the speed sensor
35	S.C. to ground at turbine speed input TCU measures a voltage less than 0.45V at speed input pin ·Cable/connector is defective and is contacted to vehicle ground ·Speed sensor has an internal defect	OP mode : Substitute clutch control If a failure is existing at output speed, TCU shifts to neutral OP mode : Limp home	<ul style="list-style-type: none"> · Check the cable from TCU to the sensor · Check the connectors · Check the speed sensor ※ This fault is reset after power up of TCU
36	Logical error at turbine speed input TCU measures a turbine speed over a threshold and at the next moment the measured speed is zero ·Cable/connector is defective and has bad contact ·Speed sensor has an internal defect ·Sensor gap has the wrong size	OP mode : Substitute clutch control If a failure is existing at output speed, TCU shifts to neutral OP mode : Limp home	<ul style="list-style-type: none"> · Check the cable from TCU to the sensor · Check the connectors · Check the speed sensor · Check the sensor gap
37	S.C. to battery voltage or O.C. at internal speed input TCU measures a voltage higher than 7.00V at speed input pin ·Cable is defective and is contacted to vehicle battery voltage ·Cable has no connection to TCU ·Speed sensor has an internal defect ·Connector pin is contacted to battery voltage or has no contact	OP mode : Substitute clutch control	<ul style="list-style-type: none"> · Check the cable from TCU to the sensor · Check the connectors · Check the speed sensor
38	S.C. to ground at turbine speed input TCU measures a voltage less than 0.45V at speed input pin ·Cable/connector is defective and is contacted to vehicle ground ·Speed sensor has an internal defect	OP mode : Substitute clutch control	<ul style="list-style-type: none"> · Check the cable from TCU to the sensor · Check the connectors · Check the speed sensor
39	Logical error at internal speed input TCU measures a internal speed over a threshold and at the next moment the measured speed is zero ·Cable/connector is defective and has bad contact ·Speed sensor has an internal defect ·Sensor gap has the wrong size	OP mode : Substitute clutch control	<ul style="list-style-type: none"> · Check the cable from TCU to the sensor · Check the connectors · Check the speed sensor · Check the sensor gap ※ This fault is reset after power up of TCU
3A	S.C. to battery voltage or O.C. at output speed input TCU measures a voltage higher than 12.5V at speed input pin ·Cable is defective and is contacted to battery voltage ·Cable has no connection to TCU ·Speed sensor has an internal defect ·Connector pin is contacted to battery voltage or has no contact	Special mode for gear selection OP mode : Substitute clutch control If a failure is existing at turbine speed, TCU shifts to neutral OP mode : Limp home	<ul style="list-style-type: none"> · Check the cable from TCU to the sensor · Check the connectors · Check the speed sensor

※ Some fault codes are not applied to this machine.

Fault code (Hex)	Meaning of the fault code possible reason for fault detection	Reaction of the TCU	Possible steps to repair
3B	S.C. to ground at output speed input TCU measures a voltage less than 1.00V at speed input pin ·Cable/connector is defective and is contacted to vehicle ground ·Speed sensor has an internal defect	Special mode for gear selection OP mode : Substitute clutch control If a failure is existing at turbine speed, TCU shifts to neutral OP mode : Limp home	<ul style="list-style-type: none"> · Check the cable from TCU to the sensor · Check the connectors · Check the speed sensor
3C	Logical error at output speed input TCU measures a turbine speed over a threshold and at the next moment the measured speed is zero ·Cable/connector is defective and has bad contact ·Speed sensor has an internal defect ·Sensor gap has the wrong size	Special mode for gear selection OP mode : Substitute clutch control If a failure is existing at turbine speed, TCU shifts to neutral OP mode : Limp home	<ul style="list-style-type: none"> · Check the cable from TCU to the sensor · Check the connectors · Check the speed sensor · Check the sensor gap ※ This fault is reset after power up of TCU
3D	Turbine speed zero doesn't fit to other speed signals	-	· Not used
3E	Output speed zero doesn't fit to other speed signals If transmission is not neutral and the shifting has finished, TCU measures output speed zero and turbine speed or internal speed not equal to zero. ·Speed sensor has an internal defect ·Sensor gap has the wrong size	Special mode for gear selection OP mode : Substitute clutch control If a failure is existing at turbine speed, TCU shifts to neutral OP mode : Limp home	<ul style="list-style-type: none"> · Check the sensor signal of output speed sensor · Check the sensor gap of output speed sensor · Check the cable from TCU to the sensor ※ This fault is reset after power up of TCU
54	DCT1 timeout Timeout of CAN-message DCT1 from display computer ·Interference on CAN-Bus ·CAN wire/connector is broken ·CAN wire/connector is defective and has contact to vehicle ground or battery voltage	OP mode : Normal	<ul style="list-style-type: none"> · Check display computer · Check wire of CAN-Bus · Check cable to display computer
55	JSS timeout Timeout of CAN-message JSS from joystick steering controller ·Interference on CAN-Bus ·CAN wire/connector is broken ·CAN wire/connector is defective and has contact to vehicle ground or battery voltage	TCU shifts to neutral while joystick steering is active OP mode : Normal	<ul style="list-style-type: none"> · Check joystick steering controller · Check wire of CAN-Bus · Check cable to joystick steering controller
56	Engine CONF timeout Timeout of CAN-message engine CONF from engine controller ·Interference on CAN-Bus ·CAN wire/connector is broken ·CAN wire/connector is defective and has contact to vehicle ground or battery voltage	OP mode : Substitute clutch control	<ul style="list-style-type: none"> · Check engine controller · Check wire of CAN-Bus · Check cable to engine controller

※ Some fault codes are not applied to this machine.

Fault code (Hex)	Meaning of the fault code possible reason for fault detection	Reaction of the TCU	Possible steps to repair
57	EEC1 timeout Timeout of CAN-message EEC1 from EEC controller ·Interference on CAN-Bus ·CAN wire/connector is broken ·CAN wire/connector is defective and has contact to vehicle ground or battery voltage	OP mode : Substitute clutch control	· Check EEC controller · Check wire of CAN-Bus · Check cable to EEC controller
58	EEC3 timeout Timeout of CAN-message EEC3 from EEC controller ·Interference on CAN-Bus ·CAN wire/connector is broken ·CAN wire/connector is defective an has contact to vehicle ground or battery voltage	OP mode : Substitute clutch control	· Check EEC controller · Check wire of CAN-Bus · Check cable to EEC controller
5C	Auto downshift signal CAN signal for automatic downshift is defective ·Cluster controller is defective ·Interference on CAN-Bus	No reaction	· Check cluster controller · Check wire of CAN-Bus · Check cable to cluster controller
5D	Manual downshift signal CAN signal for manual downshift is defective ·Cluster controller is defective ·Interference on CAN-Bus	No reaction	· Check cluster controller · Check wire of CAN-Bus · Check cable to controller
5E	CCO request signal CAN signal for CCO request is defective ·Cluster controller is defective ·Interference on CAN-Bus	No reaction	· Check cluster controller · Check wire of CAN-Bus · Check cable to controller
61	AEB request signal CAN signal for AEB request is defective ·I/O controller is defective ·Interference on CAN-Bus	No reaction OP mode : Normal	· Check I/O controller, Omron master · Check wire of CAN-Bus · Check cable to I/O controller, Omron master
64	Starting gear signal CAN signal for starting gear is defective ·I/O controller is defective (illegal starting gear) ·Interference on CAN-Bus	No reaction. TCU uses default starting gear OP mode : Normal	· Check I/O controller · Check wire of CAN-Bus · Check cable to I/O controller
65	Engine torque signal CAN signal for engine torque is defective ·Engine controller is defective ·Interference on CAN-Bus	OP mode : Substitute clutch control	· Check engine controller · Check wire of CAN-Bus · Check cable to engine controller
69	Reference engine torque signal CAN signal for reference of engine torque is defective ·Engine controller is defective ·Interference on CAN-Bus	OP mode : Substitute clutch control	· Check engine controller · Check wire of CAN-Bus · Check cable to engine controller
6A	Actual engine torque signal CAN signal for actual engine torque is defective ·Engine controller is defective ·Interference on CAN-Bus	OP mode : Substitute clutch control	· Check engine controller · Check wire of CAN-Bus · Check cable to engine controller

※ Some fault codes are not applied to this machine.

Fault code (Hex)	Meaning of the fault code possible reason for fault detection	Reaction of the TCU	Possible steps to repair
6E	EEC2 timeout Timeout of CAN-message EEC2 from EEC controller ·Interference on CAN-Bus ·CAN wire/connector is broken ·CAN wire/connector is defective and has contact to vehicle ground or battery voltage	No reaction, TCU uses default signal accelerator pedal in idle position OP mode : Normal	<ul style="list-style-type: none"> · Check EEC controller · Check wire of CAN-Bus · Check cable to EEC controller
71	S.C. to battery voltage at clutch K1 The measured resistance value of the valve is out of limit, the voltage at K1 valve is too high ·Cable/connector is defective and has contact to battery voltage ·Cable/connector is defective and has contact to another regulator output of the TCU ·Regulator has an internal defect	TCU shifts to neutral OP mode : Limp home If failure at another clutch is pending TCU shifts to neutral OP mode : TCU shutdown	<ul style="list-style-type: none"> · Check the cable from TCU to the gearbox · Check the connectors from TCU to the gearbox · Check the regulator resistance* · Check internal wire harness of the gearbox <p>* See page 3-60</p>
72	S.C. to ground at clutch K1 The measured resistance value of the valve is out of limit, the voltage at K1 valve is too low ·Cable/connector is defective and has contact to vehicle ground ·Regulator has an internal defect	TCU shifts to neutral OP mode : Limp home If failure at another clutch is pending TCU shifts to neutral OP mode : TCU shutdown	<ul style="list-style-type: none"> · Check the cable from TCU to the gearbox · Check the connectors from gearbox to TCU · Check the regulator resistance* · Check internal wire harness of the gearbox <p>* See page 3-60</p>
73	O.C. at clutch K1 The measured resistance value of the valve is out of limit ·Cable/connector is defective and has no contact to TCU ·Regulator has an internal defect	TCU shifts to neutral OP mode : Limp home If failure at another clutch is pending TCU shifts to neutral OP mode : TCU shutdown	<ul style="list-style-type: none"> · Check the cable from TCU to the gearbox · Check the connectors from gearbox to TCU · Check the regulator resistance* · Check internal wire harness of the gearbox <p>* See page 3-60</p>
74	S.C. to battery voltage at clutch K2 The measured resistance value of the valve is out of limit, the voltage at K2 valve is too high ·Cable/connector is defective and has contact to battery voltage ·Cable/connector is defective and has contact to another regulator output of the TCU ·Regulator has an internal defect	TCU shifts to neutral OP mode : Limp home If failure at another clutch is pending TCU shifts to neutral OP mode : TCU shutdown	<ul style="list-style-type: none"> · Check the cable from TCU to the gearbox · Check the connectors from gearbox to TCU · Check the regulator resistance* · Check internal wire harness of the gearbox <p>* See page 3-60</p>
75	S.C. to ground at clutch K2 The measured resistance value of the valve is out of limit, the voltage at K2 valve is too low ·Cable/connector is defective and has contact to vehicle ground ·Regulator has an internal defect	TCU shifts to neutral OP mode : Limp home If failure at another clutch is pending TCU shifts to neutral OP mode : TCU shutdown	<ul style="list-style-type: none"> · Check the cable from TCU to the gearbox · Check the connectors from gearbox to TCU · Check the regulator resistance* · Check internal wire harness of the gearbox <p>* See page 3-60</p>

※ Some fault codes are not applied to this machine.

Fault code (Hex)	Meaning of the fault code possible reason for fault detection	Reaction of the TCU	Possible steps to repair
76	O.C. at clutch K2 The measured resistance value of the valve is out of limit ·Cable/connector is defective and has no contact to TCU ·Regulator has an internal defect	TCU shifts to neutral OP mode : Limp home If failure at another clutch is pending TCU shifts to neutral OP mode : TCU shutdown	· Check the cable from TCU to the gearbox · Check the connectors from gearbox to TCU · Check the regulator resistance* · Check internal wire harness of the gearbox * See page 3-60
77	S.C. to battery voltage at clutch K3 The measured resistance value of the valve is out of limit, the voltage at K3 valve is too high ·Cable/connector is defective and has contact to battery voltage ·Cable/connector is defective and has contact to another regulator output of the TCU ·Regulator has an internal defect	TCU shifts to neutral OP mode : Limp home If failure at another clutch is pending TCU shifts to neutral OP mode : TCU shutdown	· Check the cable from TCU to the gearbox · Check the connectors from gearbox to TCU · Check the regulator resistance* · Check internal wire harness of the gearbox * See page 3-60
78	S.C. to ground at clutch K3 The measured resistance value of the valve is out of limit, the voltage at K3 valve is too low ·Cable/connector is defective and has contact to vehicle ground ·Regulator has an internal defect	TCU shifts to neutral OP mode : Limp home If failure at another clutch is pending TCU shifts to neutral OP mode : TCU shutdown	· Check the cable from TCU to the gearbox · Check the connectors from gearbox to TCU · Check the regulator resistance* · Check internal wire harness of the gearbox * See page 3-60
79	O.C. at clutch K3 The measured resistance value of the valve is out of limit ·Cable/connector is defective and has no contact to TCU ·Regulator has an internal defect	TCU shifts to neutral OP mode : Limp home If failure at another clutch is pending TCU shifts to neutral OP mode : TCU shutdown	· Check the cable from TCU to the gearbox · Check the connectors from gearbox to TCU · Check the regulator resistance* · Check internal wire harness of the gearbox * See page 3-60
7D	S.C. ground at engine derating device ·Cable is defective and is contacted to vehicle ground ·Engine derating device has an internal defect ·Connector pin is contacted to vehicle ground	Engine derating will be on until TCU power down even if fault vanishes (Loose connection) OP mode : Normal	· Check the cable from TCU to the engine derating device · Check the connectors from engine derating device to TCU · Check the resistance* of engine derating device ※ Not used * See page 3-60
7E	S.C. battery voltage at engine derating device ·Cable/connector is defective and is contacted to battery voltage ·Engine derating device has an internal defect	No reaction OP mode : Normal	· Check the cable from TCU to the engine derating device · Check the connectors from backup alarm device to TCU · Check the resistance* of backup alarm device * See page 3-60

※ Some fault codes are not applied to this machine.

Fault code (Hex)	Meaning of the fault code possible reason for fault detection	Reaction of the TCU	Possible steps to repair
7F	O.C. at engine derating device TCU detected a wrong voltage at the output pin, that looks like a O.C. for this output pin ·Cable is defective and has no connection to TCU ·Engine derating device has an internal defect ·Connector has no connection to TCU	No reaction OP mode : Normal	· Check the cable from TCU to the engine derating device · Check the connectors from engine derating device to TCU · Check the resistance* of engine derating device * See page 3-60
81	S.C. to battery voltage at clutch K4 The measured resistance value of the valve is out of limit, the voltage at K4 valve is too high ·Cable/connector is defective and has contact to battery voltage ·Cable/connector is defective and has contact to another regulator output of the TCU ·Regulator has an internal defect	TCU shifts to neutral OP mode : Limp home If failure at another clutch is pending TCU shifts to neutral OP mode : TCU shutdown	· Check the cable from TCU to the gearbox · Check the connectors from gearbox to TCU · Check the regulator resistance* · Check internal wire harness of the gearbox * See page 3-60
82	S.C. to ground at clutch K4 The measured resistance value of the valve is out of limit, the voltage at K4 valve is too low ·Cable/connector is defective and has contact to vehicle ground ·Regulator has an internal defect	TCU shifts to neutral OP mode : Limp home If failure at another clutch is pending TCU shifts to neutral OP mode : TCU shutdown	· Check the cable from TCU to the engine derating device · Check the connectors from gearbox to TCU · Check the regulator resistance* · Check internal wire harness of the gearbox * See page 3-60
83	O.C. at clutch K4 The measured resistance value of the valve is out of limit ·Cable/connector is defective and has contact to TCU ·Regulator has an internal defect	TCU shifts to neutral OP mode : Limp home If failure at another clutch is pending TCU shifts to neutral OP mode : TCU shutdown	· Check the cable from TCU to the gearbox · Check the connectors from gearbox to TCU · Check the regulator resistance* · Check internal wire harness of the gearbox * See page 3-60
84	S.C. to battery voltage at clutch KV The measured resistance value of the valve is out of limit, the voltage at KV valve is too high ·Cable/connector is defective and has contact to battery voltage ·Cable/connector is defective and has contact to another regulator output of the TCU ·Regulator has an internal defect	TCU shifts to neutral OP mode : Limp home If failure at another clutch is pending TCU shifts to neutral OP mode : TCU shutdown	· Check the cable from TCU to the gearbox · Check the connectors from gearbox to TCU · Check the regulator resistance* · Check internal wire harness of the gearbox * See page 3-60
85	S.C. to ground at clutch KV The measured resistance value of the valve is out of limit, the voltage at KV valve is too low ·Cable/connector is defective and has contact to vehicle ground ·Regulator has an internal defect	TCU shifts to neutral OP mode : Limp home If failure at another clutch is pending TCU shifts to neutral OP mode : TCU shutdown	· Check the cable from TCU to the gearbox · Check the connectors from gearbox to TCU · Check the regulator resistance* · Check internal wire harness of the gearbox * See page 3-60

※ Some fault codes are not applied to this machine.

Fault code (Hex)	Meaning of the fault code possible reason for fault detection	Reaction of the TCU	Possible steps to repair
86	O.C. at clutch KV The measured resistance value of the valve is out of limit ·Cable/connector is defective and has contact to TCU ·Regulator has an internal defect	TCU shifts to neutral OP mode : Limp home If failure at another clutch is pending TCU shifts to neutral OP mode : TCU shutdown	· Check the cable from TCU to the gearbox · Check the connectors from gearbox to TCU · Check the regulator resistance* · Check internal wire harness of the gearbox * See page 3-60
87	S.C. to battery voltage at clutch KR The measured resistance value of the valve is out of limit, the voltage at KR valve is too high ·Cable/connector is defective and has contact to battery voltage ·Cable/connector is defective and has contact to another regulator output of the TCU ·Regulator has an internal defect	TCU shifts to neutral OP mode : Limp home If failure at another clutch is pending TCU shifts to neutral OP mode : TCU shutdown	· Check the cable from TCU to the gearbox · Check the connectors from gearbox to TCU · Check the regulator resistance* · Check internal wire harness of the gearbox * See page 3-60
88	S.C. to ground at clutch KR The measured resistance value of the valve is out of limit, the voltage at KR valve is too low ·Cable/connector is defective and has contact to vehicle ground ·Regulator has an internal defect	TCU shifts to neutral OP mode : Limp home If failure at another clutch is pending TCU shifts to neutral OP mode : TCU shutdown	· Check the cable from TCU to the gearbox · Check the connectors from gearbox to TCU · Check the regulator resistance* · Check internal wire harness of the gearbox * See page 3-60
89	O.C. at clutch KR The measured resistance value of the valve is out of limit ·Cable/connector is defective and has no contact to TCU ·Regulator has an internal defect	TCU shifts to neutral OP mode : Limp home If failure at another clutch is pending TCU shifts to neutral OP mode : TCU shutdown	· Check the cable from TCU to the gearbox · Check the connectors from gearbox to TCU · Check the regulator resistance* · Check internal wire harness of the gearbox * See page 3-60
91	S.C. to ground at relay reverse warning alarm TCU detected a wrong voltage at the output pin, that looks like a S.C. to vehicle ground ·Cable is defective and is contact to vehicle ground ·Backup alarm device has an internal defect ·Connector pin is contacted to vehicle ground	Backup alarm will be on until TCU power down even if fault vanishes (Loose connection) OP mode : Normal	· Check the cable from TCU to the backup alarm device · Check the connectors from backup alarm device to TCU · Check the resistance* of backup alarm device * See page 3-60
92	S.C. to battery voltage at relay reverse warning alarm TCU detected a wrong voltage at the output pin, that looks like a S.C. to battery voltage ·Cable is defective and is contacted to battery voltage ·Backup alarm device has an internal defect ·Connector pin is contacted to battery voltage	No reaction OP mode : Normal	· Check the cable from TCU to the backup alarm device · Check the connectors from backup alarm device to TCU · Check the resistance* of backup alarm device * See page 3-60

※ Some fault codes are not applied to this machine.

Fault code (Hex)	Meaning of the fault code possible reason for fault detection	Reaction of the TCU	Possible steps to repair
93	O.C. at relay reverse warning alarm TCU detected a wrong voltage at the output pin, that looks like a O.C. for this output pin ·Cable is defective and has no connection to TCU ·Backup alarm device has an internal defect ·Connector has no connection to TCU	No reaction OP mode : Normal	<ul style="list-style-type: none"> · Check the cable from TCU to the backup alarm device · Check the connectors from backup alarm device to TCU · Check the resistance* of backup alarm device * See page 3-60
94	S.C. to ground at relay starter interlock TCU detected a wrong voltage at the output pin, that looks like a S.C. to vehicle ground ·Cable is defective and is connection to vehicle ground ·Starter interlock relay has an internal defect ·Connector pin is contacted to vehicle ground	No reaction OP mode : Normal	<ul style="list-style-type: none"> · Check the cable from TCU to the stater interlock relay · Check the connectors from starter interlock relay to TCU · Check the resistance* of starter interlock relay * See page 3-60
95	S.C. to battery voltage at relay starter interlock TCU detected a wrong voltage at the output pin, that looks like a S.C. to battery voltage ·Cable is defective and has no connection to battery voltage ·Starter interlock relay has an internal defect ·Connector pin is contacted to battery voltage	No reaction OP mode : Normal	<ul style="list-style-type: none"> · Check the cable from TCU to the starter interlock relay · Check the connectors from starter interlock relay to TCU · Check the resistance* of starter interlock relay * See page 3-60
96	O.C. at relay starter interlock TCU detected a wrong voltage at the output pin, that looks like a O.C. for this output pin ·Cable is defective and has no connection to TCU ·Starter interlock relay has an internal defect ·Connector has no connection to TCU	No reaction OP mode : Normal	<ul style="list-style-type: none"> · Check the cable from TCU to the starter interlock relay · Check the connectors from starter interlock relay to TCU · Check the resistance* of starter interlock relay * See page 3-60
9A	S.C. to ground at converter lock up clutch solenoid TCU detected a wrong voltage at the output pin, that looks like a S.C. to vehicle ground ·Cable is defective and is contacted to vehicle ground ·Converter clutch solenoid has an internal defect ·Connector pin is contacted to vehicle ground	No reaction OP mode : Normal	<ul style="list-style-type: none"> · Check the cable from TCU to the converter clutch solenoid · Check the connectors from converter clutch solenoid to TCU · Check the resistance* of converter clutch solenoid * See page 3-60

※ Some fault codes are not applied to this machine.

Fault code (Hex)	Meaning of the fault code possible reason for fault detection	Reaction of the TCU	Possible steps to repair
9B	O.C. at converter lock up clutch solenoid TCU detected a wrong voltage at the output pin, that looks like a O.C. for this output pin ·Cable is defective and has no connection to TCU ·Converter clutch solenoid has an internal defect ·Connector has no connection to TCU	Converter clutch always open, retarder not available OP mode : Normal	<ul style="list-style-type: none"> · Check the cable from TCU to the converter clutch solenoid · Check the connectors from converter clutch solenoid to TCU · Check the resistance* of converter clutch solenoid * See page 3-60
9C	S.C. to battery voltage at converter lock up clutch solenoid TCU detected a wrong voltage at the output pin, that looks like a S.C. to battery voltage ·Cable is defective and has no contacted to battery voltage ·Converter clutch solenoid has an internal defect ·Connector pin is contacted to battery voltage	No reaction OP mode : Normal	<ul style="list-style-type: none"> · Check the cable from TCU to the converter clutch solenoid · Check the connectors from converter clutch solenoid to TCU · Check the resistance* of converter clutch solenoid * See page 3-60
A1	S.C. to ground at difflock or axle connection solenoid TCU detected a wrong voltage at the output pin, that looks like a S.C. to vehicle ground ·Cable is defective and is contacted to vehicle ground ·Difflock solenoid has an internal defect ·Connector pin is contacted to vehicle ground	No reaction OP mode : Normal	<ul style="list-style-type: none"> · Check the cable from TCU to the difflock solenoid · Check the connectors from difflock solenoid to TCU · Check the resistance* of difflock solenoid * See page 3-60
A2	S.C. to battery voltage at difflock or axle connection solenoid TCU detected a wrong voltage at the output pin, that looks like a S.C. to battery voltage ·Cable is defective and has no connection to battery voltage ·Difflock solenoid has an internal defect ·Connector pin is contacted to battery voltage	No reaction OP mode : Normal	<ul style="list-style-type: none"> · Check the cable from TCU to the difflock solenoid · Check the connectors from difflock solenoid to TCU · Check the resistance* of difflock solenoid * See page 3-60
A3	O.C. at difflock or axle connection solenoid TCU detected a wrong voltage at the output pin, that looks like a O.C. for this output pin ·Cable is defective and has no connection to TCU ·Difflock solenoid has an internal defect ·Connector has no connection to TCU	No reaction OP mode : Normal	<ul style="list-style-type: none"> · Check the cable from TCU to the difflock solenoid · Check the connectors from difflock solenoid to TCU · Check the resistance* of difflock solenoid * See page 3-60

※ Some fault codes are not applied to this machine.

Fault code (Hex)	Meaning of the fault code possible reason for fault detection	Reaction of the TCU	Possible steps to repair
A4	S.C. to ground at warning signal output TCU detected a wrong voltage at the output pin, that looks like a S.C. to vehicle ground ·Cable is defective and is contacted to vehicle ground ·Warning device has an internal defect ·Connector pin is contacted to vehicle ground	No reaction OP mode : Normal	<ul style="list-style-type: none"> · Check the cable from TCU to the warning device · Check the connectors from warning device to TCU · Check the resistance* of warning device * See page 3-60
A5	O.C. voltage at warning signal output TCU detected a wrong voltage at the output pin, that looks like a O.C. for this output pin ·Cable is defective and has no connection to TCU ·Warning device has an internal defect ·Connector has no connection to TCU	No reaction OP mode : Normal	<ul style="list-style-type: none"> · Check the cable from TCU to the warning device · Check the connectors from warning device to TCU · Check the resistance* of warning device * See page 3-60
A6	S.C. to battery voltage at warning signal output TCU detected a wrong voltage at the output pin, that looks like a S.C. to battery voltage ·Cable is defective and has is contacted to battery voltage ·Warning device has an internal defect ·Connector pin is contacted to battery voltage	No reaction OP mode : Normal	<ul style="list-style-type: none"> · Check the cable from TCU to the warning device · Check the connectors from warning device to TCU · Check the resistance* of warning device * See page 3-60
B1	Slippage at clutch K1 TCU calculates a differential speed at closed clutch K1. If this calculated value is out of range, TCU interprets this as slipping clutch ·Low pressure at clutch K1 ·Low main pressure ·Wrong signal at internal speed sensor ·Wrong signal at output speed sensor ·Wrong size of the sensor gap ·Clutch is defective	TCU shifts to neutral OP mode : Limp home If failure at another clutch is pending TCU shifts to neutral OP mode : TCU shutdown	<ul style="list-style-type: none"> · Check pressure at clutch K1 · Check main pressure in the system · Check sensor gap at internal speed sensor · Check sensor gap at output speed sensor · Check signal at internal speed sensor · Check signal at output speed sensor · Replace clutch
B2	Slippage at clutch K2 TCU calculates a differential speed at closed clutch K2. If this calculated value is out of range, TCU interprets this as slipping clutch ·Low pressure at clutch K2 ·Low main pressure ·Wrong signal at internal speed sensor ·Wrong signal at output speed sensor ·Wrong size of the sensor gap ·Clutch is defective	TCU shifts to neutral OP mode : Limp home If failure at another clutch is pending TCU shifts to neutral OP mode : TCU shutdown	<ul style="list-style-type: none"> · Check pressure at clutch K2 · Check main pressure in the system · Check sensor gap at internal speed sensor · Check sensor gap at output speed sensor · Check signal at internal speed sensor · Check signal at output speed sensor · Replace clutch

※ Some fault codes are not applied to this machine.

Fault code (Hex)	Meaning of the fault code possible reason for fault detection	Reaction of the TCU	Possible steps to repair
B3	Slippage at clutch K3 TCU calculates a differential speed at closed clutch K3. If this calculated value is out of range, TCU interprets this as slipping clutch ·Low pressure at clutch K3 ·Low main pressure ·Wrong signal at internal speed sensor ·Wrong signal at output speed sensor ·Wrong size of the sensor gap ·Clutch is defective	TCU shifts to neutral OP mode : Limp home If failure at another clutch is pending TCU shifts to neutral OP mode : TCU shutdown	<ul style="list-style-type: none"> · Check pressure at clutch K3 · Check main pressure in the system · Check sensor gap at internal speed sensor · Check sensor gap at output speed sensor · Check signal at internal speed sensor · Check signal at output speed sensor · Replace clutch
B4	Slippage at clutch K4 TCU calculates a differential speed at closed clutch K4. If this calculated value is out of range, TCU interprets this as slipping clutch ·Low pressure at clutch K4 ·Low main pressure ·Wrong signal at internal speed sensor ·Wrong signal at turbine speed sensor ·Wrong size of the sensor gap ·Clutch is defective	TCU shifts to neutral OP mode : Limp home If failure at another clutch is pending TCU shifts to neutral OP mode : TCU shutdown	<ul style="list-style-type: none"> · Check pressure at clutch K4 · Check main pressure in the system · Check sensor gap at internal speed sensor · Check sensor gap at turbine speed sensor · Check signal at internal speed sensor · Check signal at turbine speed sensor · Replace clutch
B5	Slippage at clutch KV TCU calculates a differential speed at closed clutch KV. If this calculated value is out of range, TCU interprets this as slipping clutch ·Low pressure at clutch KV ·Low main pressure ·Wrong signal at internal speed sensor ·Wrong signal at turbine speed sensor ·Wrong size of the sensor gap ·Clutch is defective	TCU shifts to neutral OP mode : Limp home If failure at another clutch is pending TCU shifts to neutral OP mode : TCU shutdown	<ul style="list-style-type: none"> · Check pressure at clutch KV · Check main pressure in the system · Check sensor gap at internal speed sensor · Check sensor gap at turbine speed sensor · Check signal at internal speed sensor · Check signal at turbine speed sensor · Replace clutch
B6	Slippage at clutch KR TCU calculates a differential speed at closed clutch KR. If this calculated value is out of range, TCU interprets this as slipping clutch ·Low pressure at clutch KR ·Low main pressure ·Wrong signal at internal speed sensor ·Wrong signal at turbine speed sensor ·Wrong size of the sensor gap ·Clutch is defective	TCU shifts to neutral OP mode : Limp home If failure at another clutch is pending TCU shifts to neutral OP mode : TCU shutdown	<ul style="list-style-type: none"> · Check pressure at clutch KR · Check main pressure in the system · Check sensor gap at internal speed sensor · Check sensor gap at turbine speed sensor · Check signal at internal speed sensor · Check signal at turbine speed sensor · Replace clutch
B7	Overtemp sump TCU measured a temperature in the oil sump that is over the allowed threshold.	No reaction OP mode : Normal	<ul style="list-style-type: none"> · Cool down machine · Check oil level · Check temperature sensor
B9	Overspend engine	Retarder applies OP mode : Normal	-
BA	Differential pressure oil filter TCU measured a voltage at differential pressure switch out of the allowed range ·Oil filter is polluted ·Cable/connector is broken or cable/connector is contacted to battery voltage or vehicle ground ·Differential pressure switch is defective	No reaction OP mode : Normal	<ul style="list-style-type: none"> · Check oil filter · Check wiring from TCU to differential pressure switch · Check differential pressure switch(Measure resistance)

※ Some fault codes are not applied to this machine.

Fault code (Hex)	Meaning of the fault code possible reason for fault detection	Reaction of the TCU	Possible steps to repair
BB	Slippage at converter lockup clutch TCU calculates a differential speed at closed converter lockup clutch. If this calculated value is out of range, TCU interprets this as slipping clutch ·Low pressure at converter lockup clutch ·Low main pressure ·Wrong signal at engine speed sensor ·Wrong signal at turbine speed sensor ·Wrong size of the sensor gap ·Clutch is defective	No reaction OP mode : Normal	<ul style="list-style-type: none"> · Check pressure at converter lockup clutch · Check main pressure in the system · Check sensor gap at engine speed sensor · Check sensor gap at turbine speed sensor · Check signal at engine speed sensor · Check signal at turbine speed sensor · Replace clutch
C0	Engine torque or engine power overload TCU calculates an engine torque or engine power above the defined thresholds	OP mode : Normal	
C1	Transmission output torque overload TCU calculates an transmission output torque above the defined threshold	OP mode : Normal	
C2	Transmission input torque overload TCU calculates an transmission input torque above the defined threshold	programmable : No reaction or shift to neutral OP mode : Normal	
C3	Overtemp converter output TCU measured a oil temperature at the converter output that is the allowed threshold	No reaction OP mode : Normal	<ul style="list-style-type: none"> · Cool down machine · Check oil level · Check temperature sensor
C4	S.C. to ground at joystick status indicator TCU detected a wrong voltage at the output pin, that looks like a S.C. to vehicle ground ·Cable is defective and is contacted to vehicle ground ·Joystick status indicator has an internal defect ·Connector pin is contacted to vehicle ground	No reaction OP mode : Normal	<ul style="list-style-type: none"> · Check the cable from TCU to joystick status indicator · Check the connectors from joystick status indicator to TCU · Check the resistance* of joystick status indicator <p>* See page 3-60</p>
C5	S.C. to battery voltage at joystick status indicator TCU detected a wrong voltage at the output pin, that looks like a S.C. to battery voltage ·Cable is defective and is contacted to battery voltage ·Joystick status indicator has an internal defect ·Connector pin is contacted to battery voltage	No reaction OP mode : Normal	<ul style="list-style-type: none"> · Check the cable from TCU to joystick status indicator · Check the connectors from joystick status indicator to TCU · Check the resistance* of joystick status indicator <p>* See page 3-60</p>

※ Some fault codes are not applied to this machine.

Fault code (Hex)	Meaning of the fault code possible reason for fault detection	Reaction of the TCU	Possible steps to repair
C6	O.C. at joystick status indicator TCU detected a wrong voltage at the output pin, that looks like a O.C. for this output pin ·Cable is defective and has no connection to TCU ·Joystick status indicator has an internal defect ·Connector pin has no connection to TCU	No reaction OP mode : Normal	<ul style="list-style-type: none"> · Check the cable from TCU to joystick status indicator · Check the connectors from joystick status indicator to TCU · Check the resistance* of joystick status indicator <p>* See page 3-60</p>
D1	S.C. to battery voltage at power supply for sensors TCU measures more than 6V at the pin AU1 (5V sensor supply)	See fault codes No.21 to 2C	<ul style="list-style-type: none"> · Check cables and connectors to sensors, which are supplied from AU1 · Check the power supply at the pin AU1(Should be appx. 5V) · Fault codes No.21 to No.2C may be reaction of this fault
D2	S.C. to ground at power supply for sensors TCU measures less than 4V at the pin AU1 (5V sensor supply)	See fault codes No.21 to 2C	<ul style="list-style-type: none"> · Check cables and connectors to sensors, which are supplied from AU1 · Check the power supply at the pin AU1(Should be appx. 5V) · Fault codes No.21 to No.2C may be reaction of this fault
D3	Low voltage at battery Measured voltage at power supply is lower than 18V(24V device)	Shift to neutral OP mode : TCU shutdown	<ul style="list-style-type: none"> · Check power supply battery · Check cables from batteries to TCU · Check connectors from batteries to TCU
D4	High voltage at battery Measured voltage at power supply is higher than 32.5V(24V device)	Shift to neutral OP mode : TCU shutdown	<ul style="list-style-type: none"> · Check power supply battery · Check cables from batteries to TCU · Check connectors from batteries to TCU
D5	Error at valve power supply VPS1 TCU switched on VPS1 and measured VPS1 is off or TCU switched off VPS1 and measured VPS1 is still on ·Cable or connectors are defect and are contacted to battery voltage ·Cable or connectors are defect and are contacted to vehicle ground ·Permanent power supply KL30 missing ·TCU has an internal defect	Shift to neutral OP mode : TCU shutdown	<ul style="list-style-type: none"> · Check fuse · Check cables from gearbox to TCU · Check connectors from gearbox to TCU · Replace TCU
D6	Error at valve power supply VPS2 TCU switched on VPS2 and measured VPS2 is off or TCU switched off VPS2 and measured VPS2 is still on ·Cable or connectors are defect and are contacted to battery voltage ·Cable or connectors are defect and are contacted to vehicle ground ·Permanent power supply KL30 missing ·TCU has an internal defect	Shift to neutral OP mode : TCU shutdown	<ul style="list-style-type: none"> · Check fuse · Check cables from gearbox to TCU · Check connectors from gearbox to TCU · Replace TCU

※ Some fault codes are not applied to this machine.

Fault code (Hex)	Meaning of the fault code possible reason for fault detection	Reaction of the TCU	Possible steps to repair
E3	S.C. to battery voltage at display output TCU sends data to the display and measures always a high voltage level on the connector ·Cable or connectors are defective and are contacted to battery voltage ·Display has an internal defect	No reaction OP mode : Normal	<ul style="list-style-type: none"> · Check the cable from TCU to the display · Check the connectors at the display · Change display
E4	S.C. to ground at display output TCU sends data to the display and measures always a high voltage level on the connector ·Cable or connectors are defective and are contacted to battery voltage ·Display has an internal defect	No reaction OP mode : Normal	<ul style="list-style-type: none"> · Check the cable from TCU to the display · Check the connectors at the display · Change display
E5	Communication failure on DeviceNet	Shift to neutral OP mode : TCU shutdown	<ul style="list-style-type: none"> · Check Omron master · Check wire of DeviceNet-Bus · Check cable to Omron master
F1	General EEPROM fault TCU can't read non volatile memory ·TCU is defective	No reaction OP mode : Normal	<ul style="list-style-type: none"> · Replace TCU <p>Often shown together with fault code F2</p>
F2	Configuration lost TCU has lost the correct configuration and can't control the transmission ·Interference during saving data on non volatile memory ·TCU is brand new or from another vehicle	Transmission stay neutral OP mode : TCU shutdown	<ul style="list-style-type: none"> · Reprogram the correct configuration for the vehicle (e.g. with cluster controller,...)
F3	Application error Something of this application is wrong	Transmission stay neutral OP mode : TCU shutdown	<ul style="list-style-type: none"> · Replace TCU <p>This fault occurs only if an test engineer did something wrong in the application of the vehicle</p>
F5	Clutch failure AEB was not able to adjust clutch filling parameters ·One of the AEB-Values is out of limit	Transmission stay neutral OP mode : TCU shutdown	<ul style="list-style-type: none"> · Check clutch <p>TCU shows also the affected clutch on the display</p>
F6	Clutch adjustment data lost TCU was not able to read correct clutch adjustment parameters ·Interference during saving data on non volatile memory ·TCU is brand new	No reaction, Default values : 0 for AEB Offsets used OP mode : Normal	<ul style="list-style-type: none"> · Execute AEB and brake sensor calibration
F7	Substitute clutch control ·Transmission input torque wrong ·Engine retarder torque wrong ·Speed signal (s) defective	OP mode : Substitute clutch control	<ul style="list-style-type: none"> · Check engine retarder torque · Check speed sensors

※ Some fault codes are not applied to this machine.

5) MEASURING OF RESISTANCE AT ACTUATOR/SENSOR AND CABLE

(1) Actuator

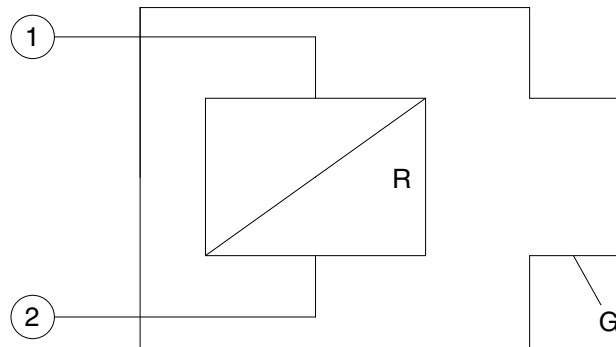

76043PT19

- Open circuit $R_{12} = R_{1G} = R_{2G} = \infty$
 Short cut to ground $R_{12} = R$; $R_{1G} = 0$, $R_{2G} = R$ or $R_{1G} = R$, $R_{2G} = 0$
 (For S.C. to ground, G is connected to vehicle ground)
 Short cut to battery $R_{12} = R$; $R_{1G} = 0$, $R_{2G} = R$ or $R_{1G} = R$, $R_{2G} = 0$
 (For S.C. to battery, G is connected to battery voltage)

(2) Cable

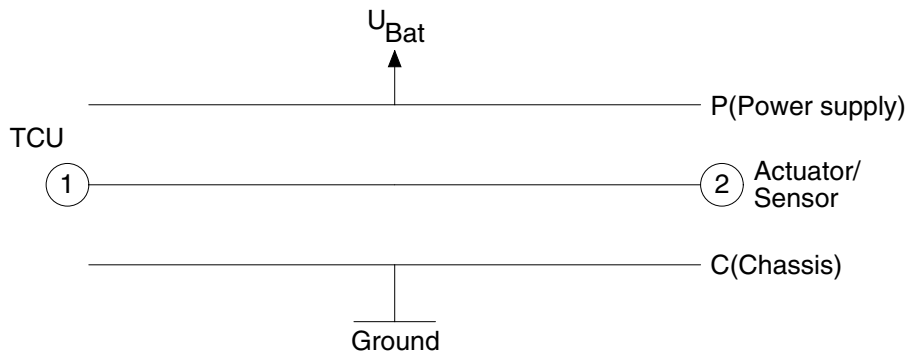

76043PT20

- Open circuit $R_{12} = R_{1P} = R_{1C} = R_{2P} = R_{2C} = \infty$
 Short cut to ground $R_{12} = 0$; $R_{1C} = R_{2C} = 0$, $R_{1P} = R_{2P} = \infty$
 Short cut to battery $R_{12} = 0$; $R_{1C} = R_{2C} = 0$, $R_{1P} = R_{2P} = 0$

5. AXLE

1) OPERATION

- The power from the engine passes through torque converter, transmission and drive shafts, and is then sent to the front and rear axles.
- Inside the axles, the power passes from the bevel pinion to the bevel gear and is sent at right angles. At the same time, the speed is reduced and passes through the both differentials to the axle shafts. The power of the axle shafts is further reduced by planetary-gear-type final drives and is sent to the wheels.

(1) Front axle

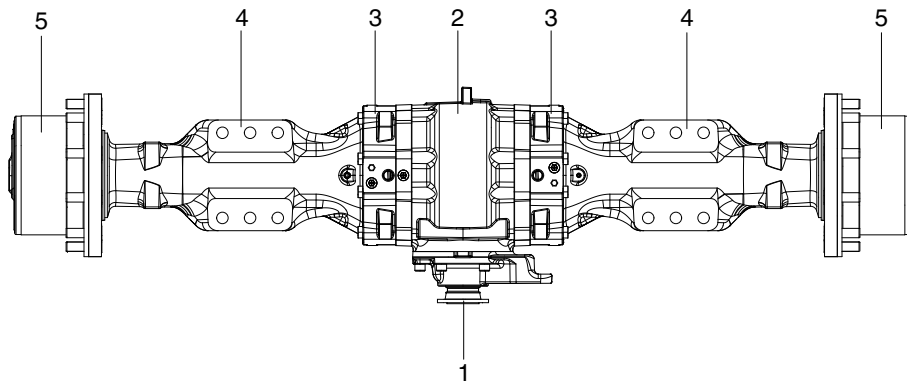

7309A3PT15

- | | | | | | |
|---|--------------|---|--------------------|---|-----------------|
| 1 | Input | 2 | Axle drive housing | 3 | Bearing housing |
| 4 | Axle housing | 5 | Output | | |

(2) Rear axle

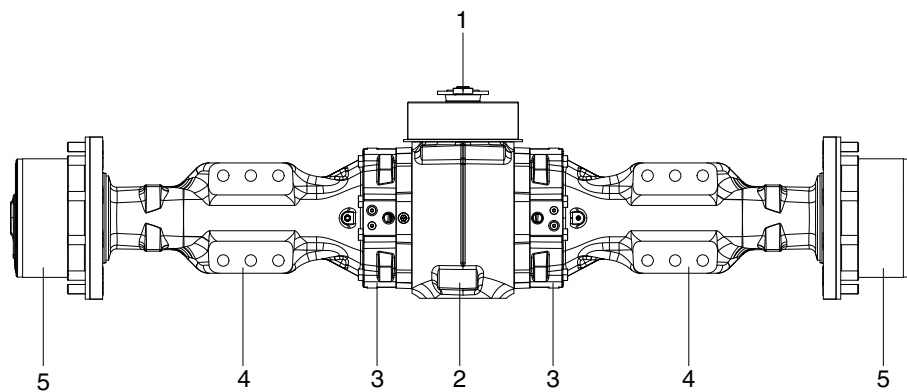

7309A3PT16

- | | | | | | |
|---|--------------|---|--------------------|---|-----------------|
| 1 | Input | 2 | Axle drive housing | 3 | Bearing housing |
| 4 | Axle housing | 5 | Output | | |

2) DIFFERENTIAL

(1) Description

When the machine makes a turn, the outside wheel must rotate faster than the inside wheel. A differential is a device which continuously transmits power to the right and left wheels while allowing them to turn a different speeds, during a turn.

The power from the drive shaft passes through bevel pinion (1) and is transmitted to the bevel gear (2). The bevel gear changes the direction of the motive force by 90 degree, and at the same time reduces the speed.

It then transmits the motive force through the differential (3) to the axle gear shaft (4).

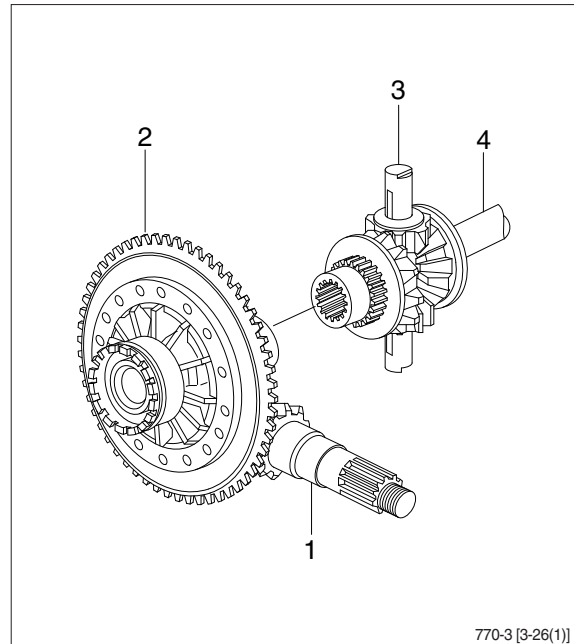

(2) When driving straight forward

When the machine is being driven straight forward and the right and left wheels are rotating at the same speed, so the pinion gear inside the differential assembly do not rotate. The motive force of the carrier is send through the pinion gear and the side gear, therefore the power is equally transmitted to the left and right axle gear shaft.

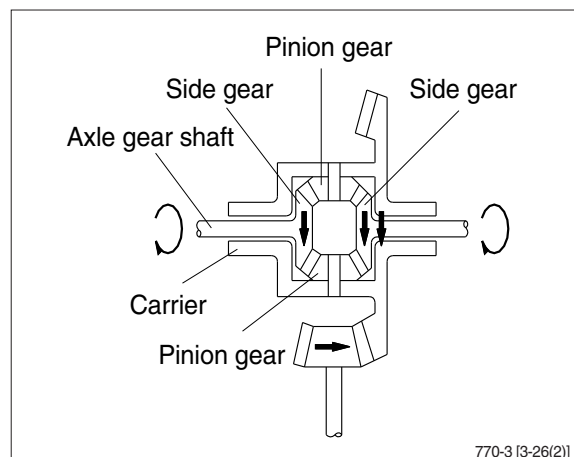

(3) When turning

When turning, the rotating speed of the left and right wheels is different, so the pinion gear and side gear inside the differential assembly rotate in accordance with the difference between the rotating speed of the left and right wheels.

The power of the carrier is then transmitted to the axle gear shafts.

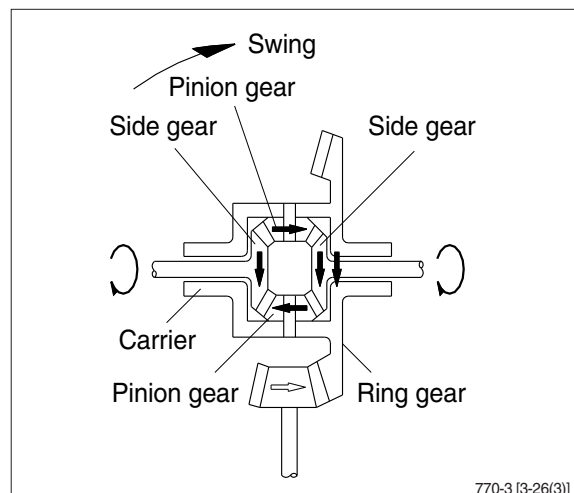

6. TIRE AND WHEEL

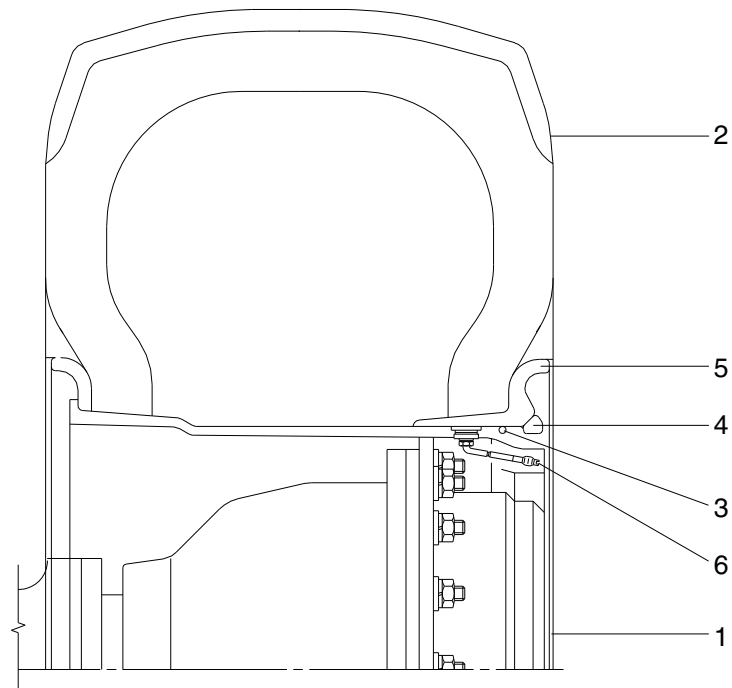

7407APT10

- | | | | | | |
|---|-----------|---|-----------|---|----------------|
| 1 | Wheel rim | 3 | O-ring | 5 | Side ring |
| 2 | Tire | 4 | Lock ring | 6 | Valve assembly |

- 1) The tire acts to absorb the shock from the ground surface to the machine, and at the same time they must rotate in contact with the ground to gain the power which drives the machine.
- 2) Various types of tires are available to suit the purpose. Therefore it is very important to select the correct tires for the type of work and bucket capacity.