

GROUP 2 SPECIFICATION

1. MAJOR COMPONENT (HL730-9A, HL730XTD-9A)

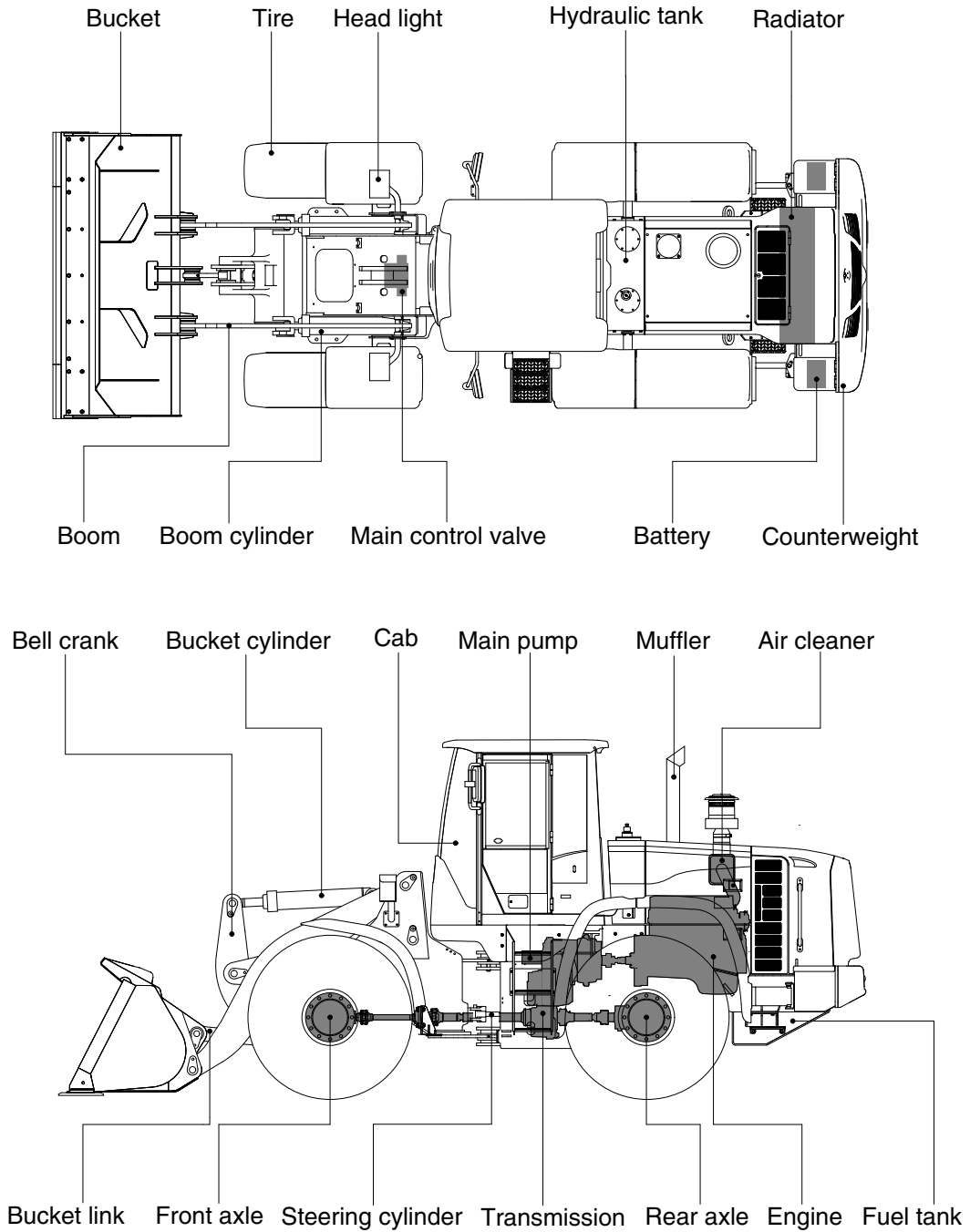

7309A2SP05

MAJOR COMPONENT (HL730TM-9A)

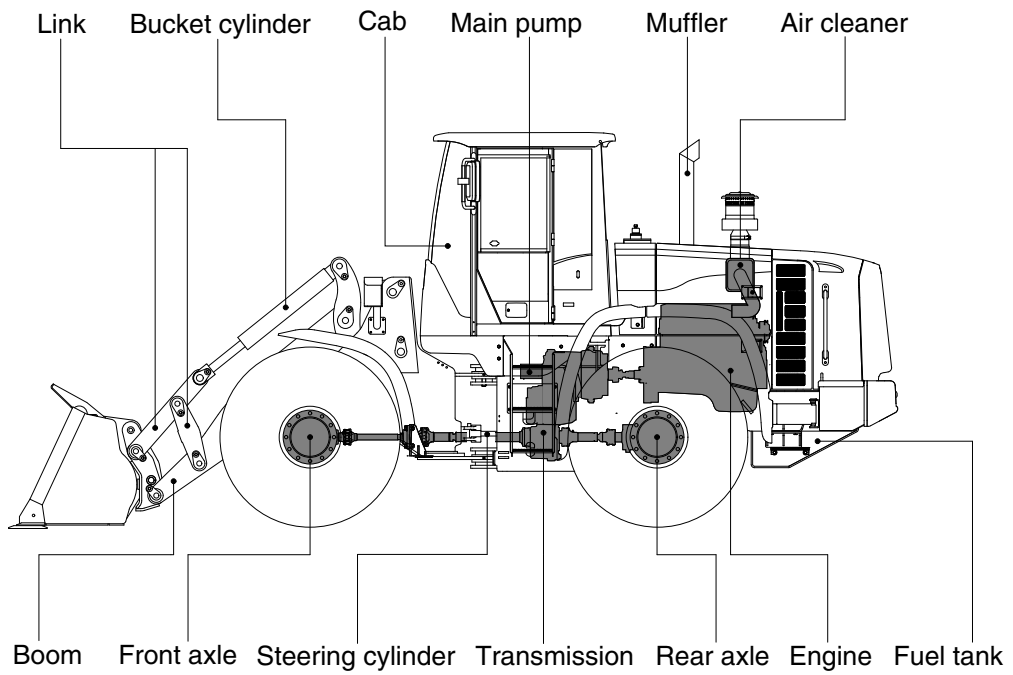
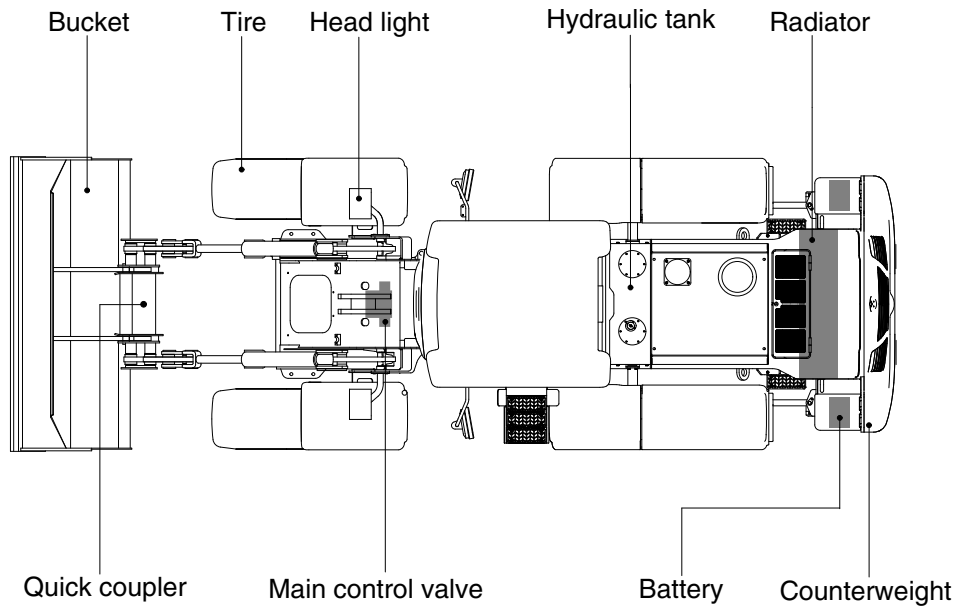

730TM9A2SP05

2. SPECIFICATIONS

1) WITH BOLT-ON CUTTING EDGE TYPE BUCKET (HL730-9A)

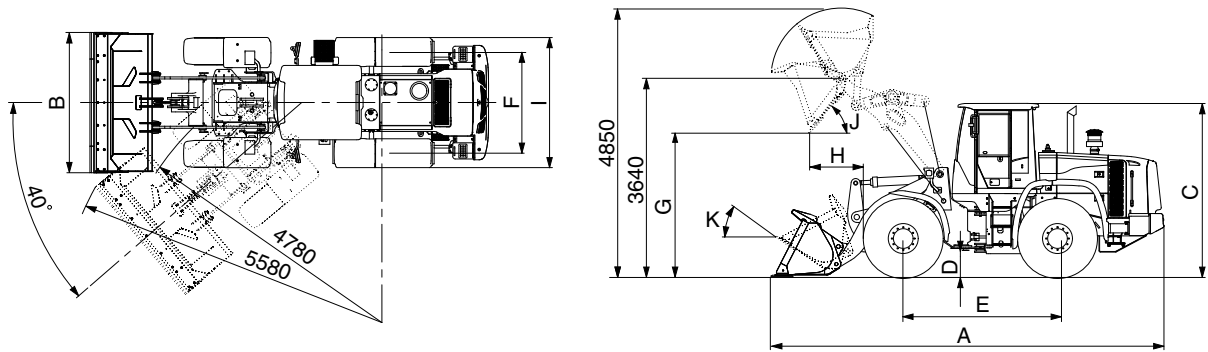

7309A2SP01

Description		Unit	Specification	
Operating weight		kg (lb)	10500 (23150)	
Bucket capacity	Struck	m ³ (yd ³)	1.6 (2.1)	
	Heaped		1.9 (2.5)	
Overall length	A	mm (ft-in)	7000 (23' 0")	
Overall width	B		2450 (8' 0")	
Overall height	C		3170 (10' 5")	
Ground clearance	D		370 (1' 3")	
Wheelbase	E		2800 (9' 2")	
Tread	F		1850 (6' 0")	
Dump clearance at 45°	G		2700 (8' 10")	
Dump reach (full lift)	H		1040 (3' 5")	
Width over tires	I		2295 (7' 6")	
Dump angle	J		degree (°)	48
Roll back angle (carry position)	K			47
Cycle time	Lift (with load)	sec	5.4	
	Dump (with load)		1.0	
	Lower (empty)		2.8	
Maximum travel speed		km/hr (mph)	39.2 (24.4)	
Braking distance		m (ft-in)	12 (39' 4")	
Minimum turning radius (center of outside tire)			4.78 (15' 8")	
Gradeability		degree (°)	30	
Breakout force		kg (lb)	9150 (20170)	
Travel speed	Forward	First gear	6.8 (4.2)	
		Second gear	12.4 (7.7)	
		Third gear	24.1 (15.0)	
		Fourth gear	39.2 (24.4)	
	Reverse	First gear	7.2 (4.5)	
		Second gear	13.1 (8.1)	
Third gear		25.3 (15.7)		

WITH BOLT-ON CUTTING EDGE TYPE BUCKET (HL730XTD-9A)

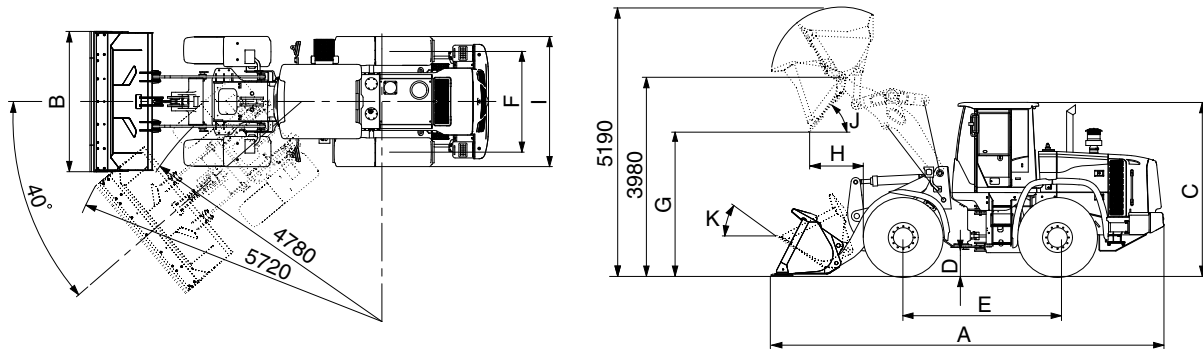

7309A2SP02

Description		Unit	Specification	
Operating weight		kg (lb)	10700 (23590)	
Bucket capacity	Struck	m ³ (yd ³)	1.6 (2.1)	
	Heaped		1.9 (2.5)	
Overall length	A	mm (ft-in)	7290 (23'11")	
Overall width	B		2450 (8' 0")	
Overall height	C		3170 (10' 5")	
Ground clearance	D		370 (1' 3")	
Wheelbase	E		2800 (9' 2")	
Tread	F		1850 (6' 0")	
Dump clearance at 45°	G		3035 (9' 11")	
Dump reach (full lift)	H		1010 (3' 4")	
Width over tires	I		2295 (7' 6")	
Dump angle	J		degree (°)	48
Roll back angle (carry position)	K			49
Cycle time	Lift (with load)	sec	5.4	
	Dump (with load)		1.0	
	Lower (empty)		2.8	
Maximum travel speed		km/hr (mph)	39.2 (24.4)	
Braking distance		m (ft-in)	12 (39' 4")	
Minimum turning radius (center of outside tire)			4.78 (15' 8")	
Gradeability		degree (°)	30	
Breakout force		kg (lb)	9070 (20000)	
Travel speed	Forward	First gear	6.8 (4.2)	
		Second gear	12.4 (7.7)	
		Third gear	24.1 (15.0)	
		Fourth gear	39.2 (24.4)	
	Reverse	First gear	7.2 (4.5)	
		Second gear	13.1 (8.1)	
Third gear		25.3 (15.7)		

WITH BOLT-ON CUTTING EDGE TYPE BUCKET (HL730TM-9A)

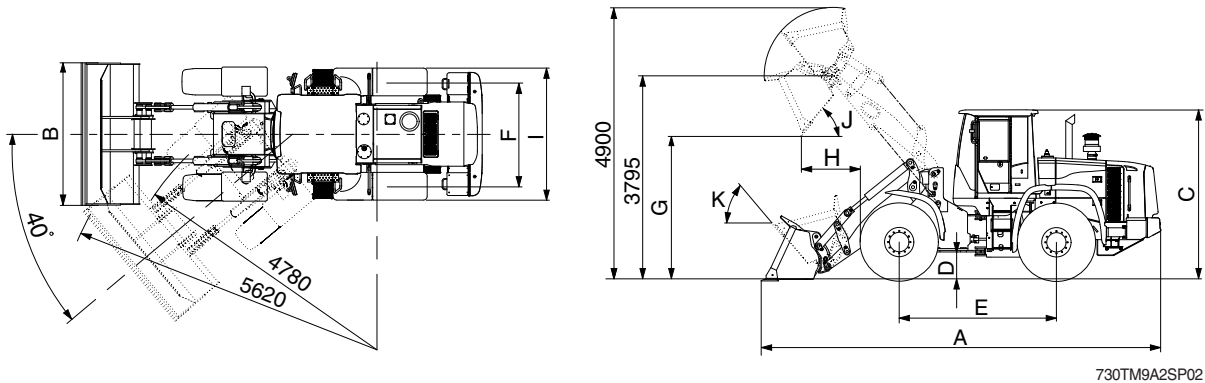

730TM9A2SP02

Description		Unit	Specification	
Operating weight		kg (lb)	10900 (24030)	
Bucket capacity	Struck	m ³ (yd ³)	1.45 (1.9)	
	Heaped		1.7 (2.2)	
Overall length	A	mm (ft-in)	7110 (23' 4")	
Overall width	B		2400 (7' 10")	
Overall height	C		3170 (10' 5")	
Ground clearance	D		370 (1' 3")	
Wheelbase	E		2800 (9' 2")	
Tread	F		1850 (6' 0")	
Dump clearance at 45°	G		2785 (9' 2")	
Dump reach (full lift)	H		1130 (3' 8")	
Width over tires	I		2295 (7' 6")	
Dump angle	J		degree (°)	50
Roll back angle (carry position)	K			54
Cycle time	Lift (with load)	sec	5.4	
	Dump (with load)		1.6	
	Lower (empty)		2.8	
Maximum travel speed		km/hr (mph)	39.2 (24.4)	
Braking distance		m (ft-in)	12 (39' 4")	
Minimum turning radius (center of outside tire)			4.78 (15' 8")	
Gradeability		degree (°)	30	
Breakout force		kg (lb)	9960 (21960)	
Travel speed	Forward	First gear	6.8 (4.2)	
		Second gear	12.4 (7.7)	
		Third gear	24.1 (15.0)	
		Fourth gear	39.2 (24.4)	
	Reverse	First gear	7.2 (4.5)	
		Second gear	13.1 (8.1)	
Third gear		25.3 (15.7)		

2) WITH TOOTH TYPE BUCKET (HL730-9A)

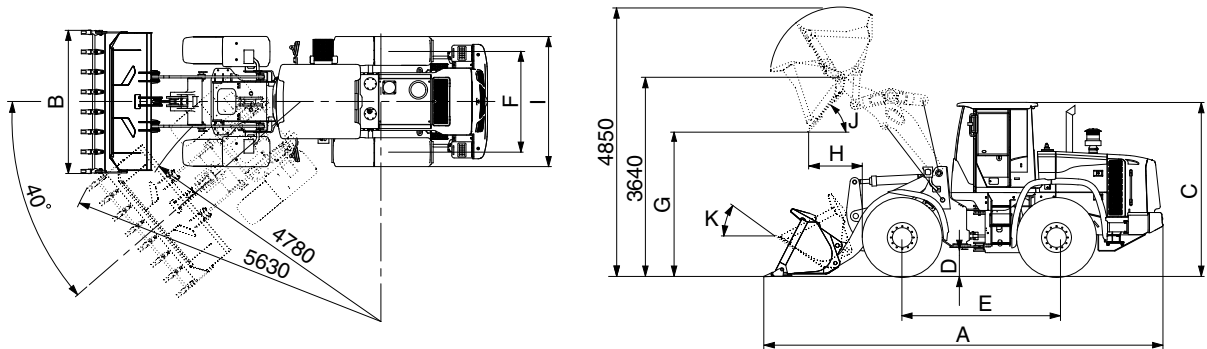

7309A2SP03

Description		Unit	Specification	
Operating weight		kg (lb)	10500 (23150)	
Bucket capacity	Struck	m ³ (yd ³)	1.5 (2.0)	
	Heaped		1.8 (2.4)	
Overall length	A	mm (ft-in)	7110 (23' 4")	
Overall width	B		2480 (8' 2")	
Overall height	C		3170 (10' 5")	
Ground clearance	D		370 (1' 3")	
Wheelbase	E		2800 (9' 2")	
Tread	F		1850 (6' 0")	
Dump clearance at 45°	G		2610 (8' 7")	
Dump reach (full lift)	H		1100 (3' 8")	
Width over tires	I		2295 (7' 6")	
Dump angle	J		degree (°)	48
Roll back angle (carry position)	K			47
Cycle time	Lift (with load)	sec	5.4	
	Dump (with load)		1.0	
	Lower (empty)		2.8	
Maximum travel speed		km/hr (mph)	39.2 (24.4)	
Braking distance		m (ft-in)	12 (39' 4")	
Minimum turning radius (center of outside tire)			4.78 (15' 8")	
Gradeability		degree (°)	30	
Breakout force		kg (lb)	9150 (20170)	
Travel speed	Forward	First gear	6.8 (4.2)	
		Second gear	12.4 (7.7)	
		Third gear	24.1 (15.0)	
		Fourth gear	39.2 (24.4)	
	Reverse	First gear	7.2 (4.5)	
		Second gear	13.1 (8.1)	
Third gear		25.3 (15.7)		

WITH TOOTH TYPE BUCKET (HL730XTD-9A)

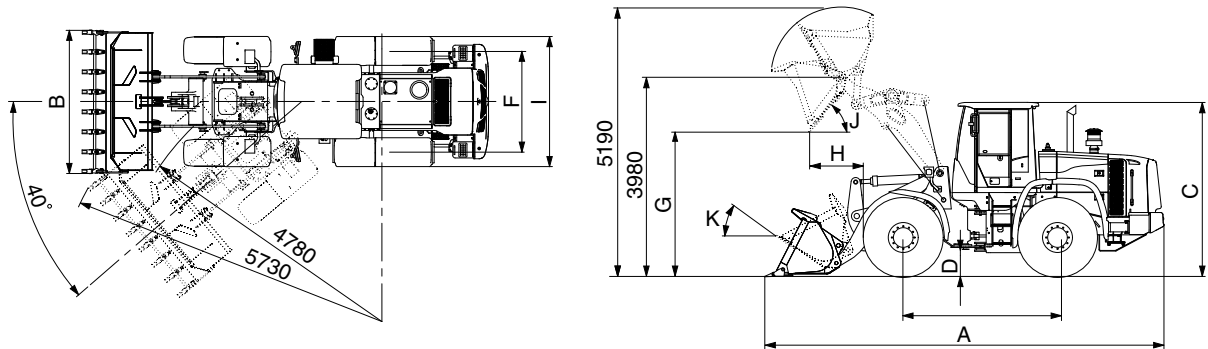

7309A2SP04

Description		Unit	Specification	
Operating weight		kg (lb)	10700 (23590)	
Bucket capacity	Struck	m ³ (yd ³)	1.5 (2.0)	
	Heaped		1.8 (2.4)	
Overall length	A	mm (ft-in)	7400 (24' 3")	
Overall width	B		2480 (8' 2")	
Overall height	C		3170 (10' 5")	
Ground clearance	D		370 (1' 3")	
Wheelbase	E		2800 (9' 2")	
Tread	F		1850 (6' 0")	
Dump clearance at 45°	G		2950 (9' 8")	
Dump reach (full lift)	H		1080 (3' 7")	
Width over tires	I		2295 (7' 6")	
Dump angle	J		degree (°)	47
Roll back angle (carry position)	K			49
Cycle time	Lift (with load)	sec	5.4	
	Dump (with load)		1.0	
	Lower (empty)		2.8	
Maximum travel speed		km/hr (mph)	39.2 (24.4)	
Braking distance		m (ft-in)	12 (39' 4")	
Minimum turning radius (center of outside tire)			4.78 (15' 8")	
Gradeability		degree (°)	30	
Breakout force		kg (lb)	9070 (20000)	
Travel speed	Forward	First gear	6.8 (4.2)	
		Second gear	12.4 (7.7)	
		Third gear	24.1 (15.0)	
		Fourth gear	39.2 (24.4)	
	Reverse	First gear	7.2 (4.5)	
		Second gear	13.1 (8.1)	
Third gear		25.3 (15.7)		

3. WEIGHT

Item		kg	lb
Front frame assembly		805	1770
Rear frame assembly		1095	2410
Front fender (LH & RH)		31	68
Counterweight	HL730-9A	300	660
	HL730XTD-9A/TM-9A	410	900
Cab assembly		700	1540
Engine assembly		390	860
Transmission assembly		425	940
Drive shaft (front)		17	37
Drive shaft (center)		17	37
Drive shaft (rear)		9	20
Drive shaft (upper)		7	15
Front axle (include differential)		520	1150
Rear axle (include differential)		530	1170
Tire (17.5-25, 12PR, L3)		130	290
Hydraulic tank assembly		192	420
Fuel tank assembly		264	580
Main pump assembly		26	57
Fan & brake pump assembly		7	15
Main control valve (2/3 spool)		34/41	75/90
Boom assembly	HL730-9A	558	1230
	HL730XTD-9A	626	1380
	HL730TM-9A	515	1140
Bell crank assembly		135	298
Bucket link		29	64
1.9 m ³ bucket, with bolt on cutting edge		810	1790
1.8 m ³ bucket, with tooth		730	1610
Boom cylinder assembly		70	150
Bucket cylinder assembly		78	170
Steering cylinder assembly		15	30
Seat		40	88
Battery		28	62

4. SPECIFICATION FOR MAJOR COMPONENTS

1) ENGINE

Item	Specification
Model	Cummins QSB4.5
Type	4-cycle turbocharged and charge air-cooled diesel engine.
Cooling method	Water cooling
Number of cylinders and arrangement	4 cylinders, in-line
Firing order	1-3-2-4
Combustion chamber type	Direct injection type
Cylinder bore × stroke	107 × 124 mm (4.2" × 4.9")
Piston displacement	4500 cc (275 cu in)
Compression ratio	17.2 : 1
Rated gross horse power	130 hp at 2200 rpm
Maximum gross torque at 1500rpm	63 kgf · m (457 lbf · ft)
Engine oil quantity	11 l (2.9 U.S. gal)
Dry weight	390 kg (860 lb)
High idling speed	2230 ± 50rpm
Low idling speed	900 ± 25 rpm
Rated fuel consumption (at rated)	221 g/kw · hr
Starting motor	Nippondenso PA90S (24 V-4.8 kW)
Alternator	Delco Remy 24SI (24V-70Amp)
Battery	2 × 12V × 100Ah

2) MAIN PUMP

Item	Specification
Type	Variable displacement piston pump
Capacity	36+32.3 cc/rev
Maximum operating pressure	250 kgf/cm ² (3560 psi)
Rated operating speed	2100 rpm
Rated output flow	126 l /min (33.3 U.S.gpm)

3) FAN AND BRAKE PUMP

Item	Specification	
	Fan	Brake
Type	Fixed displacement tandem gear pump	
Capacity	11.9 cc/rev	9.17 cc/rev
Maximum operating pressure	120 kgf/cm ² (1710 psi)	150 kgf/cm ² (2130 psi)
Rated operating speed	2100 rpm	
Rated output flow	25 l /min (6.6 U.S.gpm)	19 l /min (5.0 U.S.gpm)

4) MAIN CONTROL VALVE

Item	Specification
Type	2 spool
Operating method	Hydraulic pilot assist
Main relief valve set pressure	250 kgf/cm ² (3560 psi)
Overload relief valve set pressure	300 kgf/cm ² (4270 psi) ★150 kgf/cm ² (2130 psi)

★: Bucket dump (HL730TM-9A)

5) REMOTE CONTROL VALVE

Item	Specification	
Type	Joystick (or with aux lever)	
Control pressure	Minimum	3.7 kgf/cm ² (52.6 psi)
	Maximum	30 kgf/cm ² (427 psi)

6) CYLINDER

Item	Specification
Boom cylinder	Bore dia × Rod dia × Stroke ø 100 × ø 65 × 750 mm
Bucket cylinder	Bore dia × Rod dia × Stroke ø 110 × ø 65 × 510 mm
Bucket cylinder ★	Bore dia × Rod dia × Stroke ø 90 × ø 50 × 775 mm
Steering cylinder	Bore dia × Rod dia × Stroke ø 60 × ø 35 × 412 mm

★: HL730TM-9A

7) DYNAMIC POWER TRANSMISSION DEVICES

Item		Specification
Torque converter	Model	ZF 4WG130
	Type	Single-stage, single-phase
	Ratio	2.381 : 1
Transmission	Type	Full-automatic power shift
	Gear shift	Forward fourth gear, reverse third gear
	Control	Electrical single lever type, kick-down system
	Pump rated flow	85 ℓ /min (22.5 U.S.gpm) at 2000 rpm
Axle	Drive devices	4-wheel drive
	Front	Front fixed location
	Rear	Oscillation $\pm 12^\circ$ of center pin-loaded
Wheels	Tires	17.5-25, 12PR (L3)
Brakes	Travel	Four-wheel, wet-disc type, full hydraulic
	Parking	Spring applied, hydraulic released brake on transmission
Steering	Type	Full hydraulic, articulated
	Steering angle	40° to both right and left angle, respectively

5. TIGHTENING TORQUE OF MAJOR COMPONENT

No.	Descriptions	Bolt size	Torque		
			kgf · m	lbf · ft	
1	Engine	Engine mounting bolt, nut (rubber, 2EA)	M16×2.0	29.7 ± 4.5	215 ± 32.5
2		Engine mounting bolt (bracket, 6EA)	M12×1.75	10.7 ± 1.6	77.4 ± 11.6
3		Radiator mounting bolt (6EA)	M16×2.0	29.7 ± 4.5	215 ± 32.5
4		Fuel tank mounting bolt, nut	M16×2.0	29.7 ± 4.5	215 ± 32.5
5		Air cleaner mounting bolt	M16×1.0	3.95	28.6
6		Air cleaner bracket mounting bolt	M12×1.75	10.7 ± 1.6	77.4 ± 11.6
7		DOC mounting U-bolt, nut	M10×1.5	6.9 ± 1.4	50 ± 10.1
8	Hydraulic system	Main pump housing mounting bolt	M12×1.75	12.8 ± 3.0	92.6 ± 21.7
9		Fan & brake pump housing mounting bolt	M10×1.5	6.9 ± 1.4	50 ± 10.1
10		Main control valve mounting bolt	M10×1.5	6.9 ± 1.4	50 ± 10.1
11		Steering unit mounting bolt	M10×1.5	6.9 ± 1.4	50 ± 10.1
12		Cushion valve mounting bolt	M8×1.25	2.5 ± 0.5	18.1 ± 3.6
13		Brake valve mounting bolt	M10×1.5	6.9 ± 1.4	50 ± 10.1
14		Cut-off valve mounting bolt	M12×1.75	12.8 ± 3.0	92.6 ± 21.7
15		Remote control lever mounting bolt	M6×1.0	1.1 ± 0.2	8.0 ± 1.4
16		Safety valve mounting bolt	M10×1.5	6.9 ± 1.4	50 ± 10.1
17		Hydraulic oil tank mounting bolt	M16×2.0	29.7 ± 4.5	215 ± 32.5
18	Power train system	Transmission mounting bolt, nut (rubber, 2EA)	M20×2.5	57.9 ± 8.7	419 ± 63
19		Transmission mounting bolt (bracket, 6EA)	M16×2.0	18.4 ± 2.0	133 ± 14.5
20		Front axle mounting bolt, nut	M27×2.0	135 ± 15	976 ± 108
21		Rear axle support mounting bolt, nut	M24×2.0	135 ± 15	976 ± 108
22		Tire mounting nut	M22×1.5	77.4 ± 11.6	560 ± 83.9
23		Drive shaft joint mounting bolt, nut	3/8-24UNF	6.0 ± 0.8	43.4 ± 5.8
24	Others	Counterweight mounting bolt	M30×3.5	199 ± 30	1439 ± 216
25		Operator's seat mounting bolt	M8×1.25	3.4 ± 0.7	24.6 ± 5.1
26		ROPS Cab mounting bolt (4EA)	M20×2.5	58 ± 8.7	419 ± 63
27		ROPS Cab mounting nut (4EA)	M16×2.0	29.7 ± 4.5	215 ± 32.5

6. TORQUE CHART

Use following table for unspecified torque.

1) BOLT AND NUT

(1) Coarse thread

Bolt size	8T		10T	
	kg · m	lb · ft	kg · m	lb · ft
M 6 × 1.0	0.85 ~ 1.25	6.15 ~ 9.04	1.14 ~ 1.74	8.2 ~ 12.6
M 8 × 1.25	2.0 ~ 3.0	14.5 ~ 21.7	2.73 ~ 4.12	19.5 ~ 29.8
M10 × 1.5	4.0 ~ 6.0	28.9 ~ 43.4	5.5 ~ 8.3	39.8 ~ 60
M12 × 1.75	7.4 ~ 11.2	53.5 ~ 79.5	9.8 ~ 15.8	71 ~ 114
M14 × 2.0	12.2 ~ 16.6	88.2 ~ 120	16.7 ~ 22.5	121 ~ 167
M16 × 2.0	18.6 ~ 25.2	135 ~ 182	25.2 ~ 34.2	182 ~ 247
M18 × 2.5	25.8 ~ 35.0	187 ~ 253	35.1 ~ 47.5	254 ~ 343
M20 × 2.5	36.2 ~ 49.0	262 ~ 354	49.2 ~ 66.6	356 ~ 482
M22 × 2.5	48.3 ~ 63.3	350 ~ 457	65.8 ~ 98.0	476 ~ 709
M24 × 3.0	62.5 ~ 84.5	452 ~ 611	85.0 ~ 115	615 ~ 832
M30 × 3.0	124 ~ 168	898 ~ 1214	169 ~ 229	1223 ~ 1655
M36 × 4.0	174 ~ 236	1261 ~ 1703	250 ~ 310	1808 ~ 2242

(2) Fine thread

Bolt size	8T		10T	
	kg · m	lb · ft	kg · m	lb · ft
M 8 × 1.0	2.17 ~ 3.37	15.7 ~ 24.3	3.04 ~ 4.44	22.0 ~ 32.0
M10 × 1.25	4.46 ~ 6.66	32.3 ~ 48.2	5.93 ~ 8.93	42.9 ~ 64.6
M12 × 1.25	7.78 ~ 11.58	76.3 ~ 83.7	10.6 ~ 16.0	76.6 ~ 115
M14 × 1.5	13.3 ~ 18.1	96.2 ~ 130	17.9 ~ 24.1	130 ~ 174
M16 × 1.5	19.9 ~ 26.9	144 ~ 194	26.6 ~ 36.0	193 ~ 260
M18 × 1.5	28.6 ~ 43.6	207 ~ 315	38.4 ~ 52.0	278 ~ 376
M20 × 1.5	40.0 ~ 54.0	289 ~ 390	53.4 ~ 72.2	386 ~ 522
M22 × 1.5	52.7 ~ 71.3	381 ~ 515	70.7 ~ 95.7	512 ~ 692
M24 × 2.0	67.9 ~ 91.9	491 ~ 664	90.9 ~ 123	658 ~ 890
M30 × 2.0	137 ~ 185	990 ~ 1338	182 ~ 248	1314 ~ 1795
M36 × 3.0	192 ~ 260	1389 ~ 1879	262 ~ 354	1893 ~ 2561

2) PIPE AND HOSE (FLARE type)

Thread size	Width across flat (mm)	kgf · m	lbf · ft
1/4"	19	4	28.9
3/8"	22	5	36.2
1/2"	27	9.5	68.7
3/4"	36	18	130
1"	41	21	152
1-1/4"	50	35	253

3) PIPE AND HOSE (ORFS type)

Thread size	Width across flat (mm)	kgf · m	lbf · ft
9/16-18	19	4	28.9
11/16-16	22	5	36.2
13/16-16	27	9.5	68.7
1-3/16-12	36	18	130
1-7/16-12	41	21	152
1-11/16-12	50	35	253

4) FITTING

Thread size	Width across flat (mm)	kgf · m	lbf · ft
1/4"	19	4	28.9
3/8"	22	5	36.2
1/2"	27	9.5	68.7
3/4"	36	18	130
1"	41	21	152
1-1/4"	50	35	253

7. RECOMMENDED LUBRICANTS

Use only oils listed below or equivalent.
Do not mix different brand oil.

Service point	Kind of fluid	Capacity ℓ (U.S. gal)	Ambient temperature °C (°F)							
			-50 (-58)	-30 (-22)	-20 (-4)	-10 (14)	0 (32)	10 (50)	20 (68)	30 (86)
Engine oil pan	Engine oil	11 (2.9)	★ ² SAE 5W-40							
			SAE 30							
			SAE 10W							
			SAE 10W-30							
			SAE 15W-40							
Transmission	Engine oil	20 (5.3)	SAE 10W-30							
			SAE 15W-40							
Axle	UTTO	FR : 17 (4.5) RR : 17 (4.5)	★ Refer to below list							
Hydraulic tank	Hydraulic oil	Tank; 121 (32.0) System; 154 (40.7)	★ ² ISO VG 15							
			ISO VG 46							
			ISO VG 68							
Fuel tank	Diesel fuel★ ¹	200 (52.8)	★ ² ASTM D975 NO.1							
			ASTM D975 NO.2							
Fitting (grease nipple)	Grease	As required	★ ² NLGI NO.1							
			NLGI NO.2							
Radiator (reservoir tank)	Mixture of antifreeze and water	30 (7.9)	Ethylene glycol base permanent type (50 : 50)							
			★ ² Ethylene glycol base permanent type (60 : 40)							

SAE : Society of Automotive Engineers
API : American Petroleum Institute
ISO : International Organization for Standardization
NLGI : National Lubricating Grease Institute
ASTM : American Society of Testing and Material
UTTO : Universal Tractor Transmission Oil

★ Recommended oil list
- BP TERRAC SUPER TRANSMISSION 10W-30
- CASTROL AGRI TRANS PLUS 10W-30
- MOBILFLUID 426
- SHELL DONAX TD 10W-30
- TOTAL DYNATRANS MPV
★¹ Ultra low sulfur diesel
- sulfur content ≤ 15 ppm
★² Cold region
- Russia, CIS, Mongolia