

GROUP 4 DISASSEMBLY AND ASSEMBLY

1. MAIN PUMP

1) STRUCTURE (1/2)

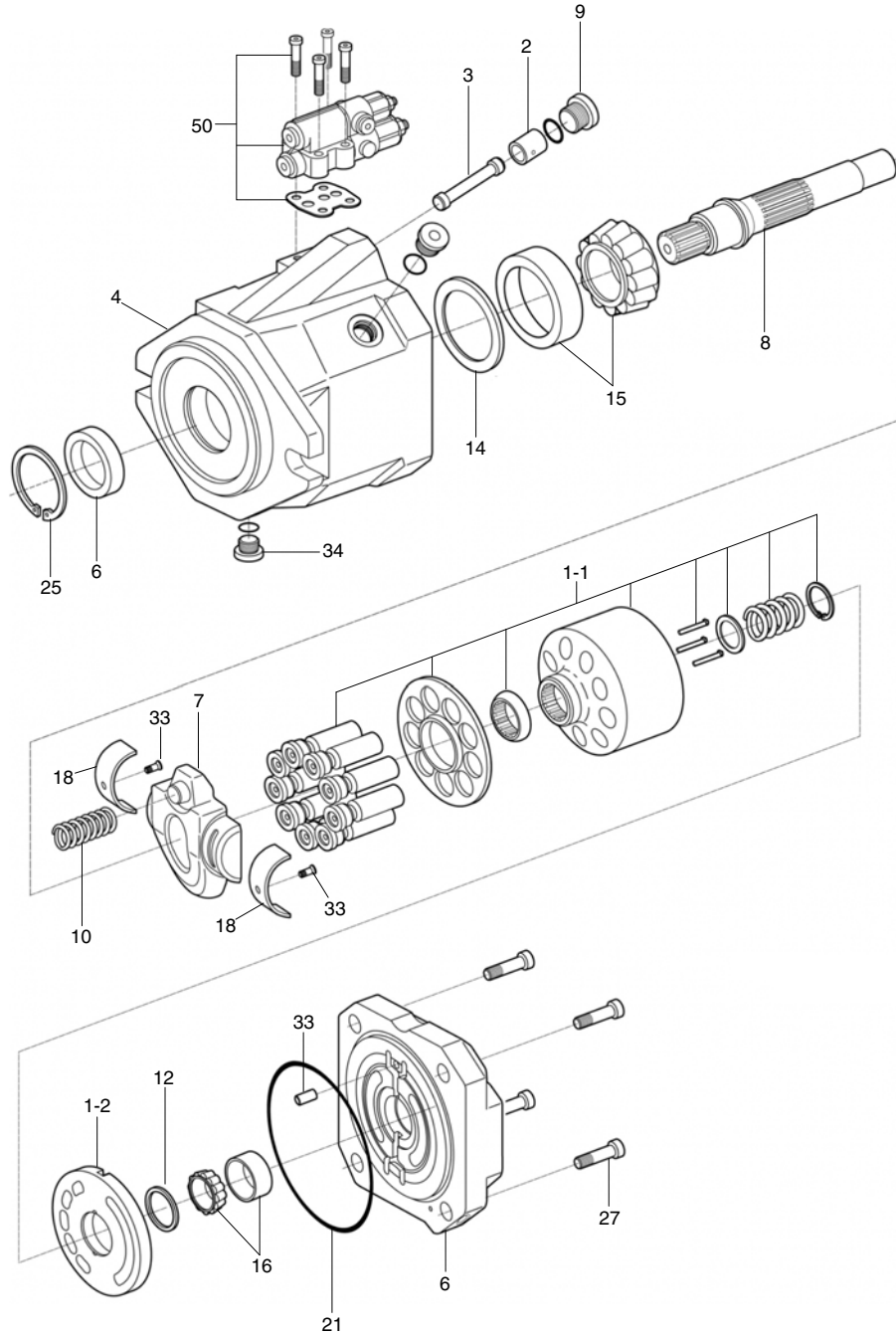

- | | | | | | |
|-----|-------------------------|----|----------------------|----|-----------------|
| 1 | Rotary group | 8 | Drive shaft | 18 | Bearing liner |
| 1-1 | High speed rotary group | 9 | Locking screw | 21 | O-ring |
| 1-2 | Control plate | 10 | Spring | 25 | Retaining ring |
| 2 | Control piston | 12 | Adjustment shim | 27 | Socket screw |
| 3 | Piston rod | 14 | Stop ring | 33 | Cylinder pin |
| 4 | Pump housing | 15 | Taper roller bearing | 34 | Locking screw |
| 6 | Shaft seal | 16 | Taper roller bearing | 40 | Flat head screw |
| 7 | Swash plate | 17 | Bearing liner | 50 | Control valve |

73096WE11

2) GENERAL REPAIR GUIDELINES

- ※ Observe the following guidelines when carrying out repairs on hydraulic pumps.
- (1) Close off all openings of the hydraulic unit.
- (2) Replace all of the seals.
Use only original spare parts.
- (3) Check all sealing and sliding surfaces for wear.
- ※ Re-work of the sliding surfaces by using, for example abrasive paper, can damage the surface.
- (4) Fill the hydraulic pump with hydraulic oil before commissioning.

3) SEALING THE DRIVE SHAFT

- | | | | |
|---|----------------|---|------------|
| 1 | Retaining ring | 2 | Shaft seal |
| 3 | Bearing | 4 | Stop ring |

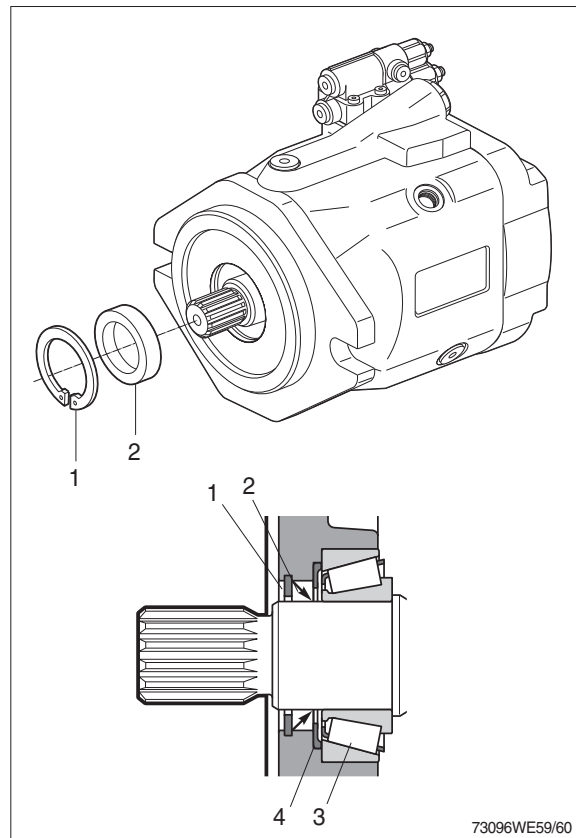

- (1) Protect the drive shaft.
Wrap the drive shaft with tape.
Remove the retaining ring.
Remove shaft seal to front.

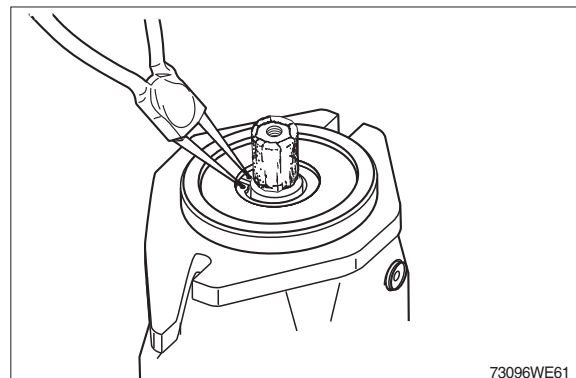

- ※ Change the shaft seal and check its sliding surface (drive shaft) and housing, grease the sealing ring.
Visual check shaft seal and housing.

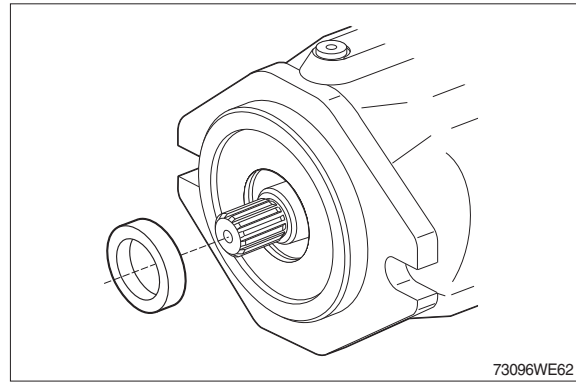

- (2) Assembling of the sealing ring carefully down to the stop ring.

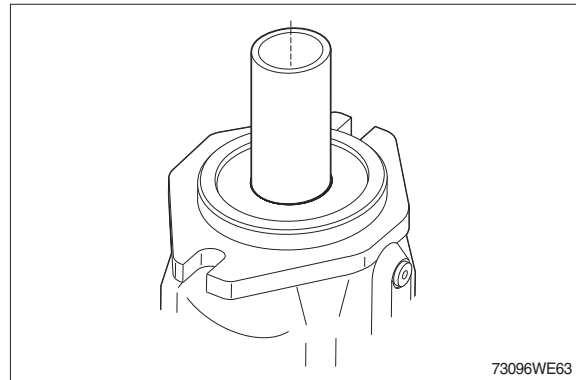

- (3) Assemble the retaining ring (circlip).
※ Visual check to ensure that the circlip is correctly located in the groove.

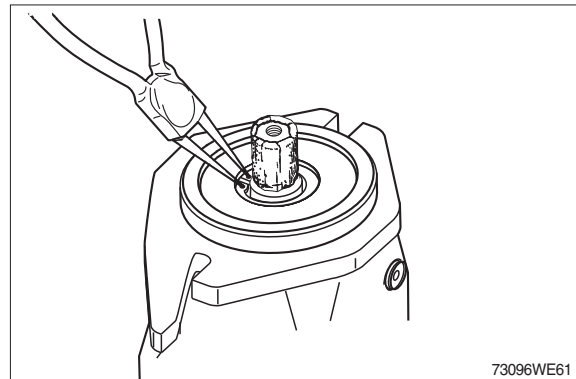

4) SEALING THE CONTROL VALVE

- (1) Remove the control valve.

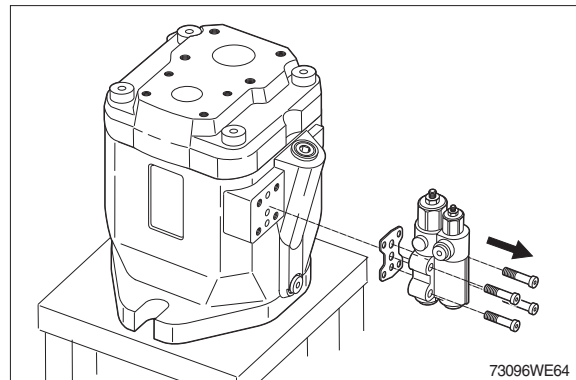

- (2) Measure dimension A, B and note down.
 Check sealing surface (1).
 Replace gasket (2).

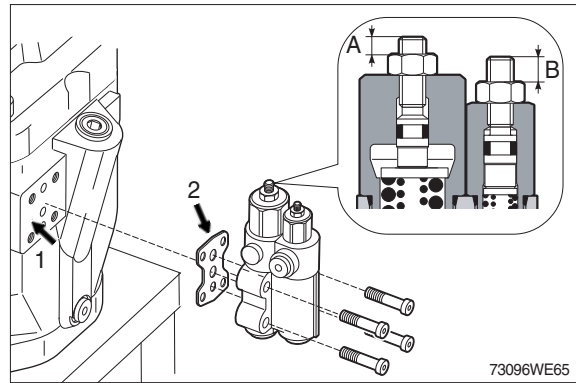

- (3) Assemble control valve.
 Tighten the bolts.
 · Tightening torque : 1.58 kgf · m
 (11.4 lbf · ft)

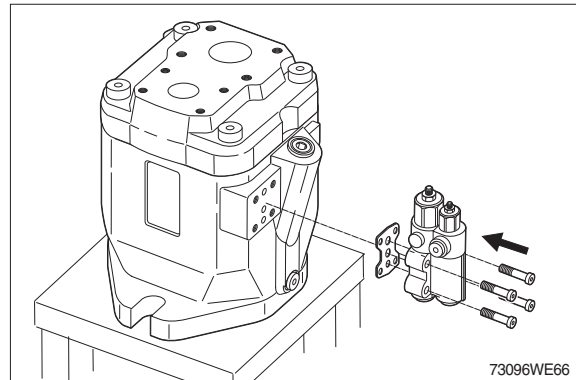

- (4) Check dimension A, B.

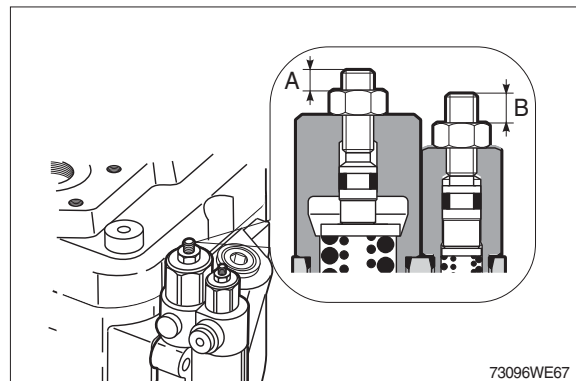

5) INSPECT HINTS

- (1) Renew all bearings.

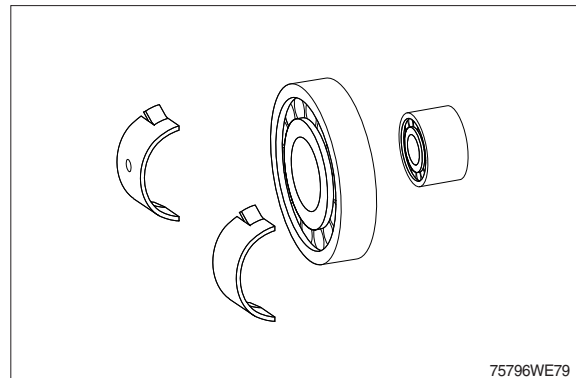

(2) Check :

- 1 Wear on splines, rust
- 2 Drive shaft seal wear grooves
- 3 Bearing seat
- 4 Splines for cylinder drive
- 5 Bearing seat

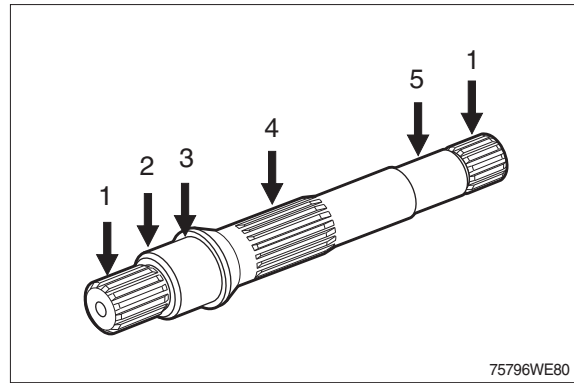

(3) Check :

Sliding surface free of grooves.

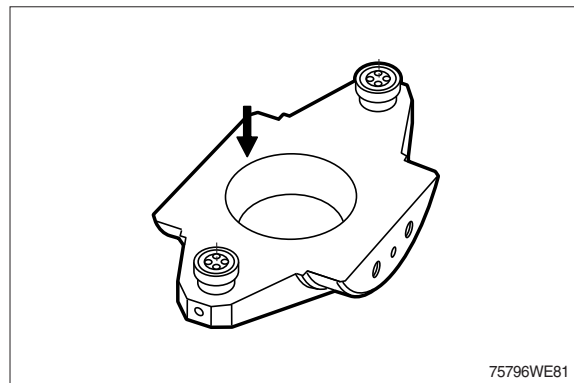

(4) Check :

Bearing surfaces.

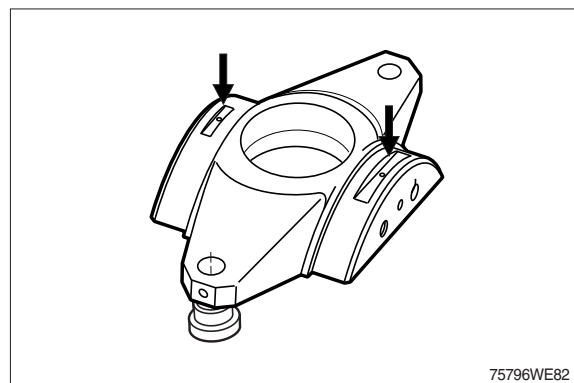

(5) Check :

That the retaining plate is free of grooves and that there is no wear in the slipper pad area.

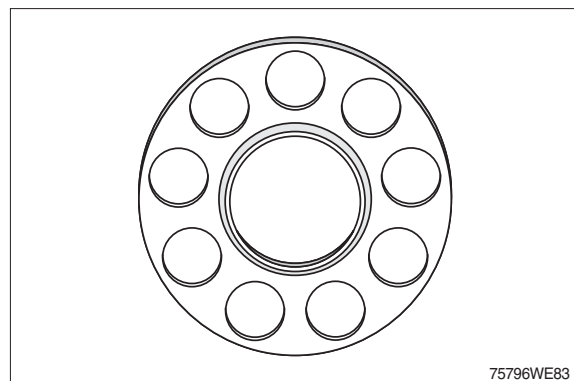

(6) Check :

Check to see that there are no scratches or metal deposits on the sliding surface (1) and that there is no axial play (2) (Pistons must only be replaced as a set).

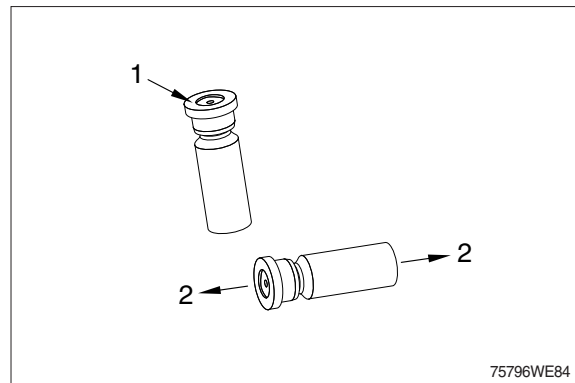

(7) Check :

- 1 Cylinder bores
- 2 Splines

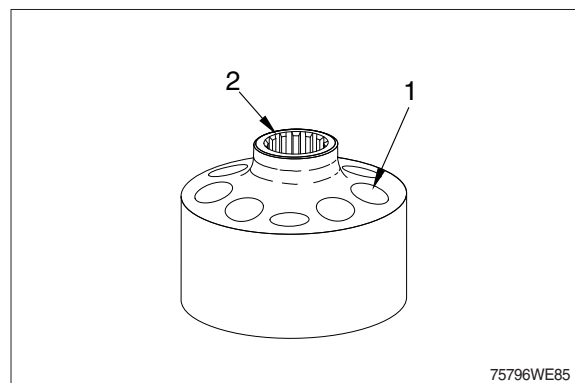

(8) Free of grooves, no signs of wear.

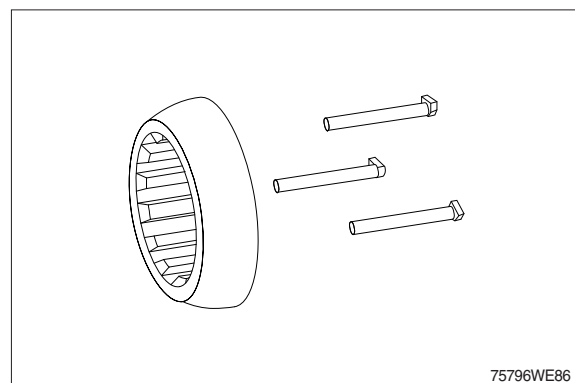

(9) Check :

Cylinder sliding surface free of grooves, no wear, no embedded foreign particles. That there are no scratches on the control plate. (Only replace them as a set).

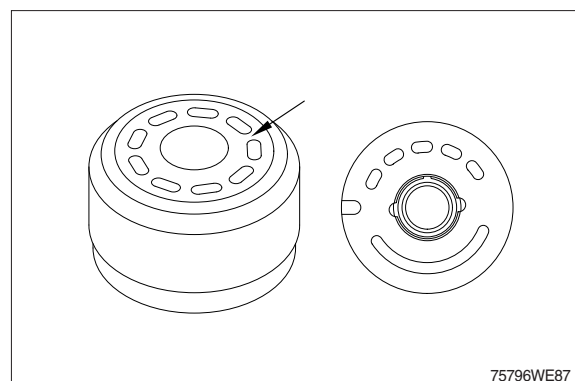

2. MAIN CONTROL VALVE

1) STRUCTURE (1/2)

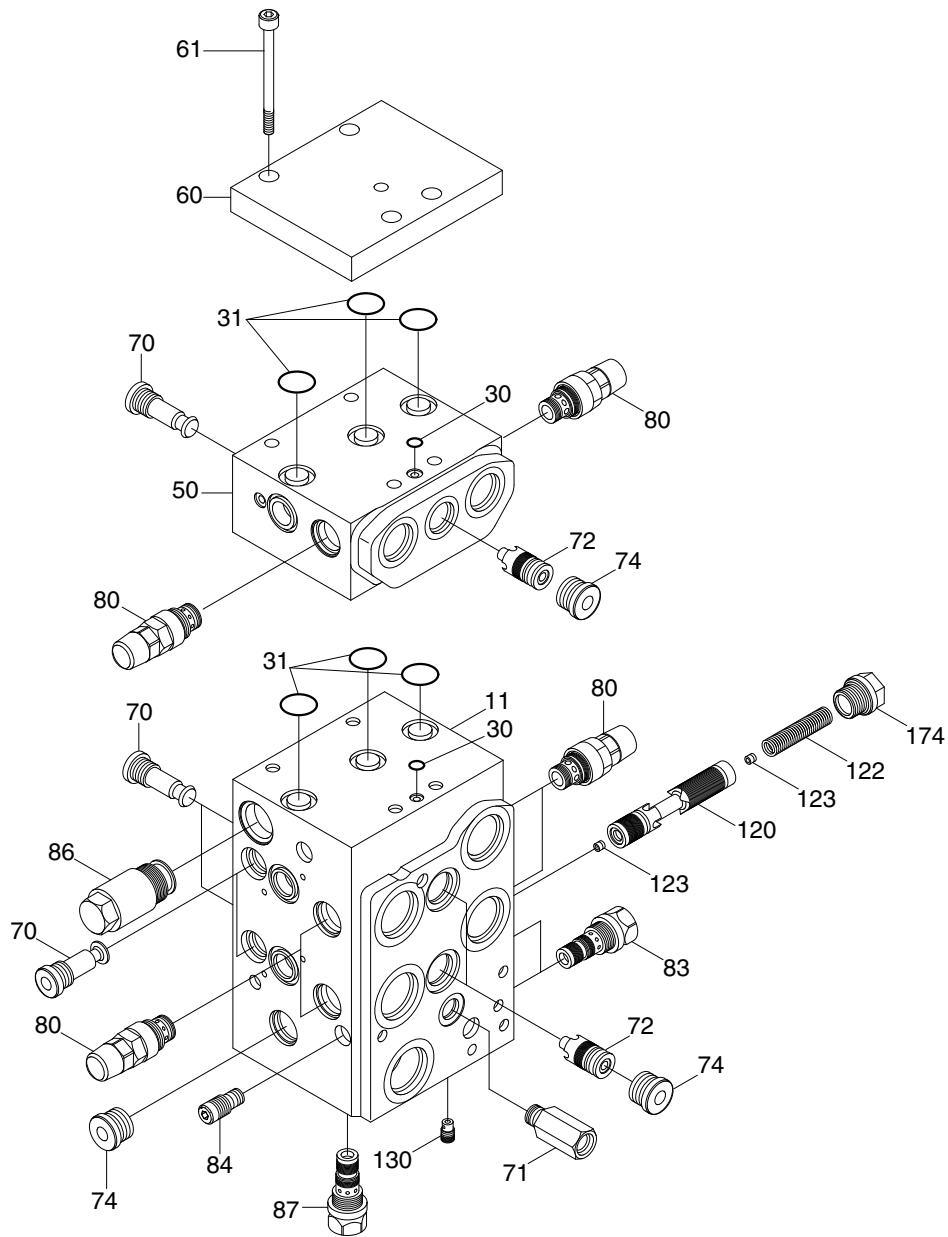

74096WE13

11	Housing	71	Shuttle valve	87	Pressure reducing valve
30	O-ring	72	Spool	120	Spool
31	O-ring	74	Locking screw	122	Pressure spring
50	Housing	80	Pressure relief valve	123	Orifice
60	Plate	83	Pressure relief valve	130	Check valve
61	Cylinder screw	84	Flow control valve	174	Locking screw
70	Check valve	86	Counter balance valve		

STRUCTURE (2/2)

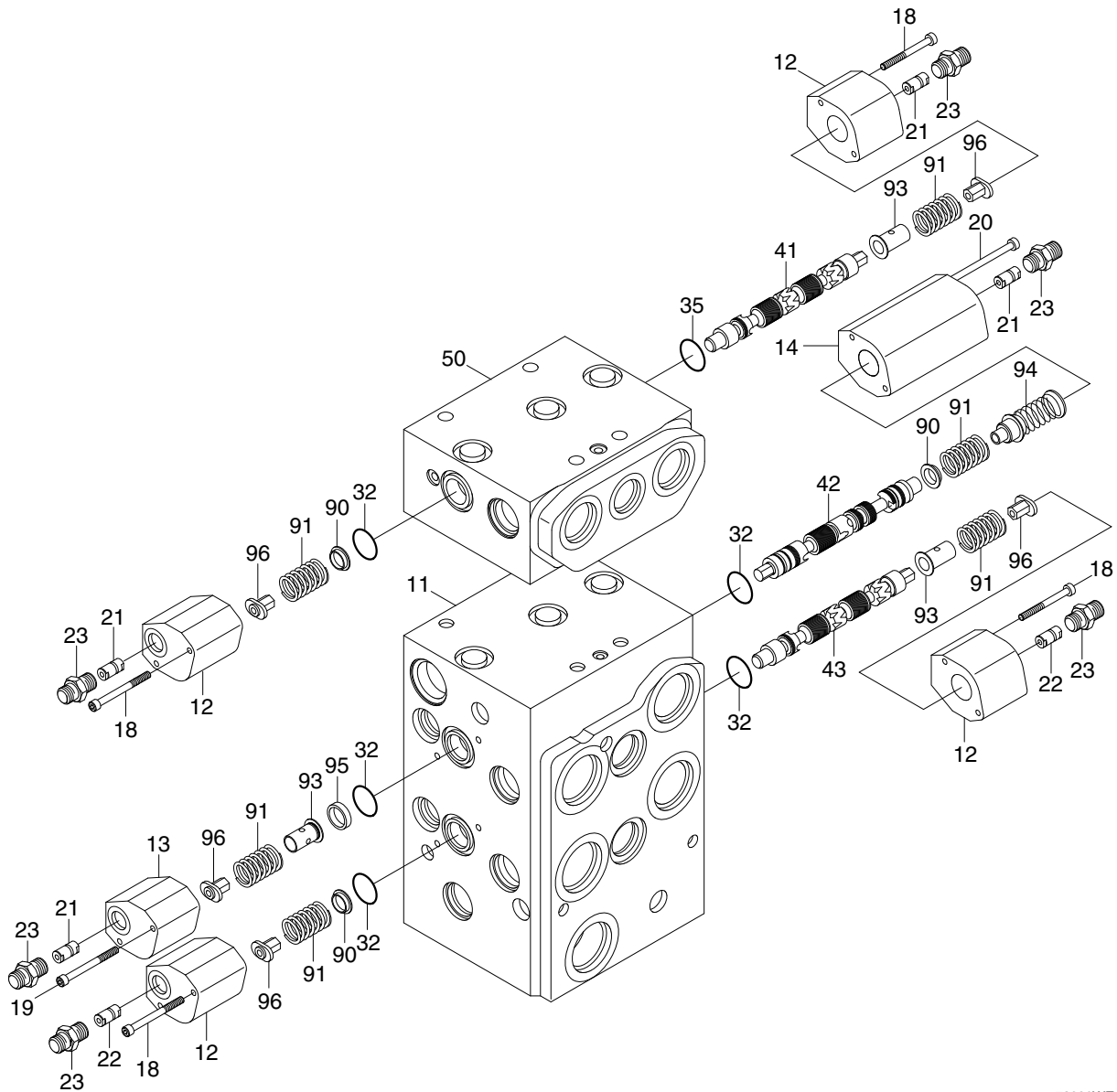

73096WE14

- | | | | | | |
|----|----------------------|----|-----------------------------|----|--------------------|
| 11 | Housing | 22 | Throttle check valve | 90 | Spring retainer |
| 12 | Cover | 23 | Threaded steel pipe fitting | 91 | Compression spring |
| 13 | Cover | 32 | O-ring | 93 | Spring retainer |
| 14 | Cover | 35 | O-ring | 94 | Spring |
| 18 | Cylinder screw | 41 | Spool | 95 | Ring |
| 19 | Cylinder screw | 42 | Spool | 96 | Spring retainer |
| 20 | Cylinder screw | 43 | Spool | | |
| 21 | Throttle check valve | 50 | Housing | | |

2) GENERAL PRECAUTIONS

- (1) Clean room with no dust is recommended for maintenance. Because hydraulic components are precision, and have minute clearance. Tool and wash-oil must be clean, too. Handle them carefully.
- (2) At removing control valve from the machine, wash around the piping port, and neither dust nor water should go into inside with plugging. It is same at attaching the machine.
- (3) Prepare the required parts by checking structure figure before assembly. There are parts which are supplied with only sub-assembly part, so check the parts list before assembly.

3) PRECAUTIONS FOR DISASSEMBLY

- (1) Handle the components carefully not to drop them or bump them with each other as they are made with precision.
- (2) Do not force the work by hitting or twisting as burred or damaged component may not be assembled or result in oil leakage or low performance.
- (3) When disassembled, tag the components for identification so that they can be reassembled correctly.
- (4) Once disassembled, O-ring and back-up rings are usually not to be used again.(Remove them using a wire with its end made like a shoe-horn. Be careful not to damage the slot)
- (5) If the components are left disassembled or half-disassembled, they may get rust from moisture or dust. If the work has to be interrupted, take care to prevent rust and dust.

4) PRECAUTIONS FOR REASSEMBLY

- (1) Take the same precautions as for disassembly.
- (2) When assembling the components, remove any metal chips or foreign objects and check them for any burrs or dents. Remove burrs and dents with oil-stone, if any.
- (3) O-rings and back-up rings are to be replaced with new ones, as a rule.
- (4) When installing O-rings and back-up rings, be careful not to damage them. (Apply a little amount of grease for smoothness)
- (5) Tighten the bolts and caps with specified torque.

5) DISASSEMBLY AND ASSEMBLY

(1) Spool

- ① Loosen the bolt (2EA).
 - Tool : Wrench 4 mm
 - Tightening torque : 0.85 kgf·m
(61 lbf·ft)

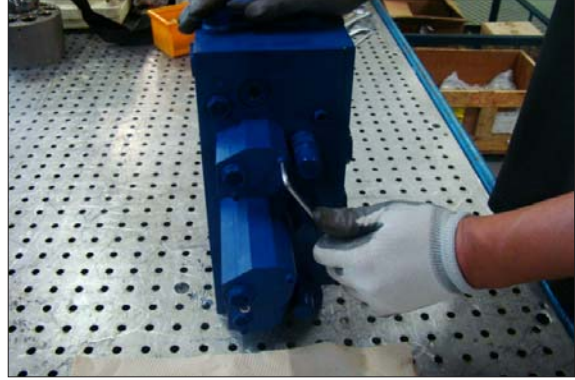

75796WE41

- ② Remove the cover, spring retainer, spring and spool.

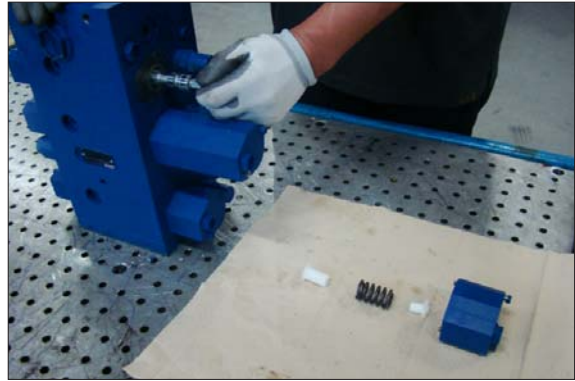

75796WE42

- 1 Spool
- 2 Spring
- 2 Spring retainer
- 4 Bolt
- 5 Cover

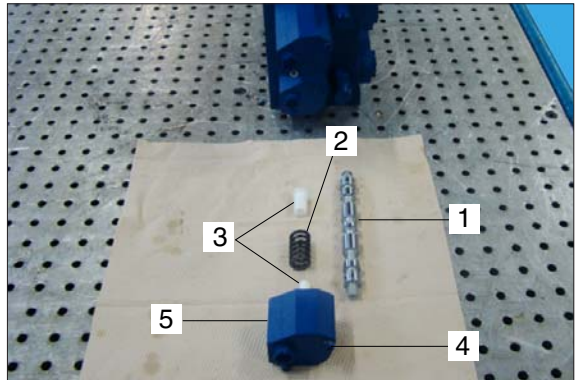

75796WE43

(2) Port relief valve

- Tool : Spanner 24 mm

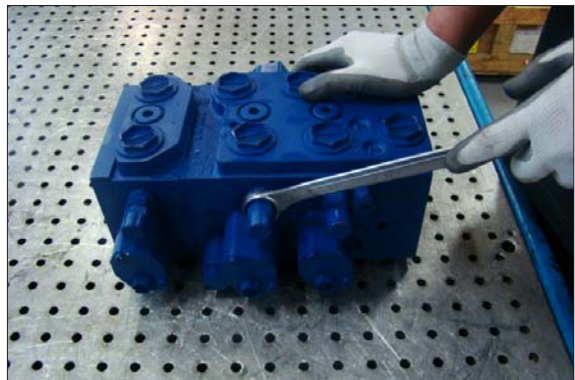

75796WE44

- Tightening torque : 10.2 kgf·m
(73.8 lbf·ft)

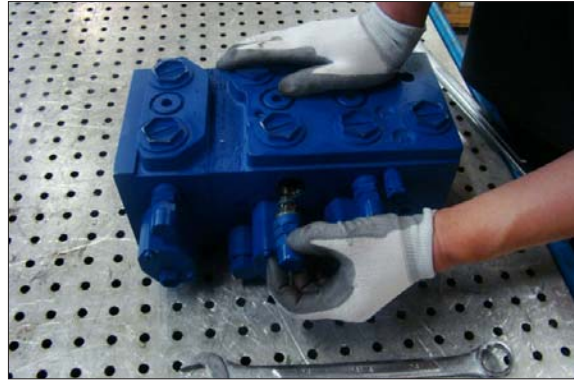

75796WE45

(3) Precharge valve

- Tool : Spanner 24 mm

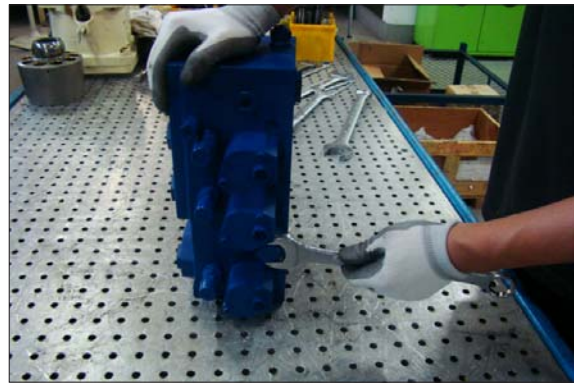

75796WE46

- Tightening torque : 6.1 kgf·m
(44.3 lbf·ft)

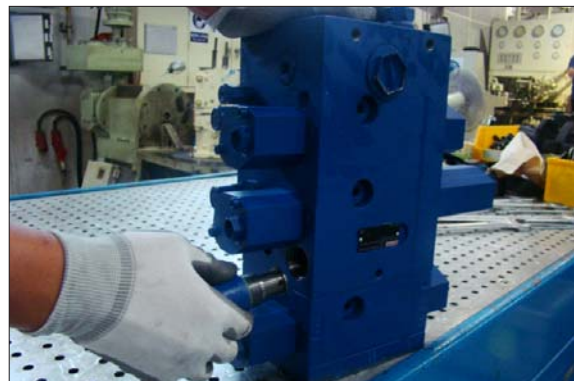

75796WE47

3. REMOTE CONTROL VALVE

1) STRUCTURE

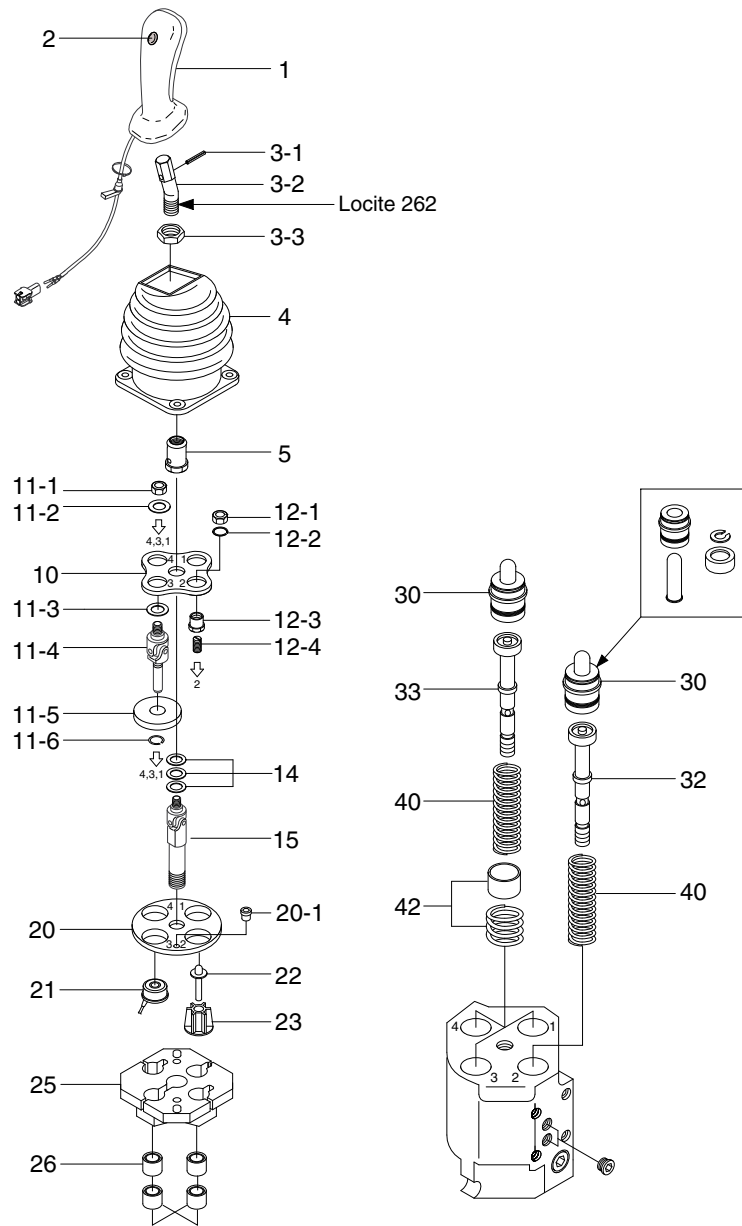

7707WE64

- | | | | | | |
|------|------------------|------|--------------------------|----|----------------------------|
| 1 | Handle | 11-4 | Cardan | 22 | Intermediary plunger kit |
| 2 | Push button | 11-5 | Armature | 23 | Intermediary plunger guide |
| 3-1 | Locking pin | 11-6 | Spring ring | 25 | Electric bracket |
| 3-2 | Bent lever | 12-1 | Counter nut | 26 | Bushing |
| 3-3 | Nut | 12-2 | Spring ring | 30 | Plunger kit |
| 4 | Rubber boot | 12-3 | Switch plate screw | 32 | Regulation unit |
| 5 | Locking nut | 12-4 | Press screw | 33 | Regulation unit |
| 10 | Cardan bracket | 14 | Shims (0.1, 0.2, 0.5 mm) | 40 | Return spring |
| 11-1 | Self-locking nut | 15 | Cardan | 42 | Prefeeling point kit |
| 11-2 | Washer | 20 | Flange | | |
| 11-3 | Washer | 21 | Solenoid | | |

2) DISASSEMBLY AND ASSEMBLY

(1) PUSH BUTTON

- ※ The remote control valve does not need to be removed from the machine to perform this operation.

Remove worn pushbutton using a small screwdriver.

The installation of new elements is performed without any special tools; the parts are simply pressed into place.

(2) RUBBER BOOT

- ① Remove the remote control valve from the machine or free the valve by unscrewing the 4 screws fixing the plate in order to release the electrical cable.

·Assembly

Torque : 1.02 kgf·m (7.4 lbf·ft)

Hold the remote control valve using a vice or a vice-grip wrench (clamp onto the body).

- ※ The pilot unit does not need to be removed from the machine to release the cable. However, it is recommended to lift the control unit by undoing the 4 fixing screws on the arm rest.
- ※ It is unnecessary to remove the units with no electrical functions.

- ② Lift and turn the boot inside out.

- ③ Remove the grommet (7) from its emplacement to free the cable.

- ④ Loosen the handle mounting nut (3-3) using a 19 mm open-end wrench.

·Assembly : torque 4.08 kgf·m (29.5 lbf·ft)

- ⑤ Unscrew and remove the handle (1).

·Assembly

- Add loctite 262 onto the lever thread

- Torque : 4.08 kgf·m (29.5 lbf·ft)

- ⑥ Replace the faulty rubber boot (4) with a new one.

- ⑦ Replace the handle (1) following the disassembly instructions in reverse order.

(3) HANDLE

- ① Clamp the threaded section of the lever (3-2) in a vice fitted with V-shaped vice clamp.

- ② Remove the pin (3-1) using a 5mm pin driver.

- ③ Replace the lever (3-2) onto the new handle (1) and secure it with the pin (3-1) using a 5mm pin driver.

- ※ Respect the position of the curved lever to ensure that the handle is correctly oriented as indicated by the machine's technical specifications.

- ④ Replace the nut (3-3) on the threaded section and replace the boot (4).

(4) DETENT CARDAN BRACKET KIT

- ※ Remove the 2 grommets (20-1) from the flange (20).
- ※ Place centering sleeves V & W to avoid damaging the cardan knuckles while loosening the nuts.
- ※ Unscrew the locking nut (5) using a 23mm open-end wrench.
 - Assembly : Torque 4.08 ± 0.4 kgf·m
(29.5 ± 2.9 lbf·ft)

- ① Unscrew the self-locking nut (11-1) using a 13mm open-end wrench.
 - Assembly
 - Torque 1.02 kgf·m (7.4 lbf·ft)
 - Place centering sleeves (V-W) to avoid damaging the cardan knuckles while screwing the nuts.
- ② Remove : - Friction washer (11-2)
 - Friction washer (11-3)
 - Cardan/armature assembly (11-4 ~ 11-6)

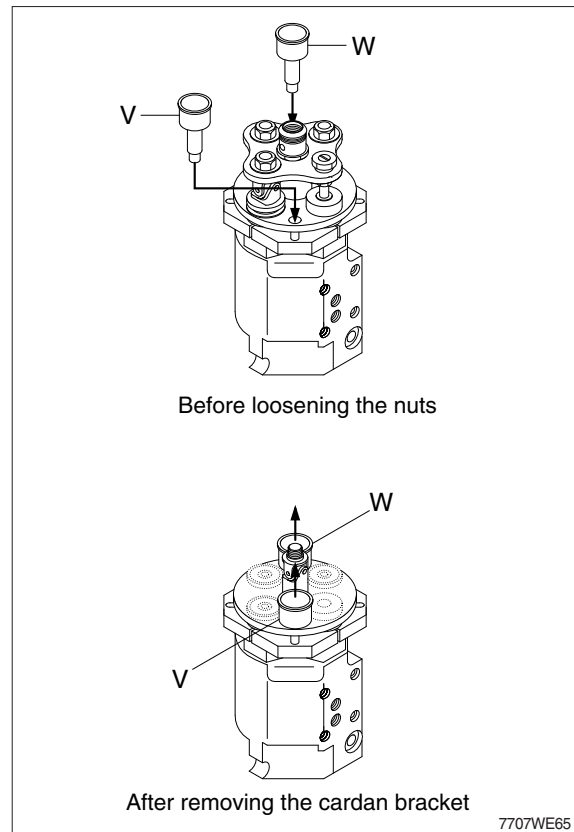

(5) NON-DETENT PLUNGER KIT

- ① Unscrew the self-locking nut (12-1) using a 13 mm open-end wrench.
 - Reassembly : - Torque 1.02 kgf·m (7.4 lbf·ft)
 - Place centering sleeves (V-W) to avoid damaging the cardan knuckles while screwing the nuts.
- ② Undo the snap ring (12-2) using a flat-end screwdriver.
- ③ Remove the screw assembly (12-3, 12-4)

(6) CARDAN

- ① Remove the centering sleeves V & W.
- ② Remove the cardan bracket (10) and the shims (14).
- ③ Unscrew the cardan (15) using a 17 mm open-end wrench.
 - Reassembly : - Ungrease the cardan threads
 - Add loctite 262 onto the cardan threads (both end)
 - Torque 4.08 kgf·m (29.5lbf·ft)

(7) SOLENOID AND CONNECTOR

- ※ It is advised to mount the connector onto the solenoid cable once the remote control valve is assembled.
- ① Remove the flange (20) and the electrical bracket (25),
 - ② Remove the protecting bushes (26) from the electrical bracket (25).
 - ③ Undo the solenoid (21) from the electric bracket (25).
 - ④ Replace the solenoid.
 - ※ Clean the polar face using a piece of cloth and pay attention not to hit them.
 - ⑤ Assembly : Place the solenoid cable in its emplacement on the electric bracket before fitting the protection bushes.

(8) INTERMEDIARY PLUNGER KIT

- ① Undo the intermediary plunger guide (23).
- ② Remove and replace the intermediary plunger kit assembly (22).

(9) GUIDE / PLUNGER AND REGULATION UNIT

※ Beware of the plungers that might jump out due to the spring return.

- ① Remove : - Guide/plunger assembly (30).
 - Regulation unit (32/33).
 - Return spring (40).
 - Pre-feeling point kit (42).
- ② The remote control valve is now totally disassembled.
Assemble in reverse order following the torque specification.