

SECTION 6 WORK EQUIPMENT

Group 1 Structure and Function	6-1
Group 2 Operational Checks and Troubleshooting	6-40
Group 3 Tests and Adjustments	6-50
Group 4 Disassembly and Assembly	6-65

SECTION 6 WORK EQUIPMENT

GROUP 1 STRUCTURE AND FUNCTION

1. HYDRAULIC SYSTEM OUTLINE

The loader hydraulic system is a pilot operated, closed center system which is supplied with flow from the variable displacement piston main hydraulic pump.

The loader system components are :

- Main pump
- Main control valve
- Bucket cylinder
- Boom cylinders
- Remote control valve (Pilot control valve)
- Safety valve

The main control valve is load pressure independent flow distribution system which routes flow to the boom, bucket or auxiliary cylinders (not shown) when the respective spools are shifted.

Flow from the main pump is routed to the main control valve where pump outlet pressure is reduced to pilot circuit pressure. The main control valve flow to the remote control valve.

The remote control valve routed flow to either end of each spool valve section in the main control valve to control spool stroke.

A accumulator mounted on safety valve supplies a secondary pressure source to operated remote control valve so the boom can be lowered if the engine is off.

The return circuit for the main hydraulic system have return filter inside the hydraulic tank. The return filter uses a filter element and a bypass valve. The bypass valve is located in the upside of filter.

2. HYDRAULIC CIRCUIT (HL730-9, HL730XTD-9, ~#0235)

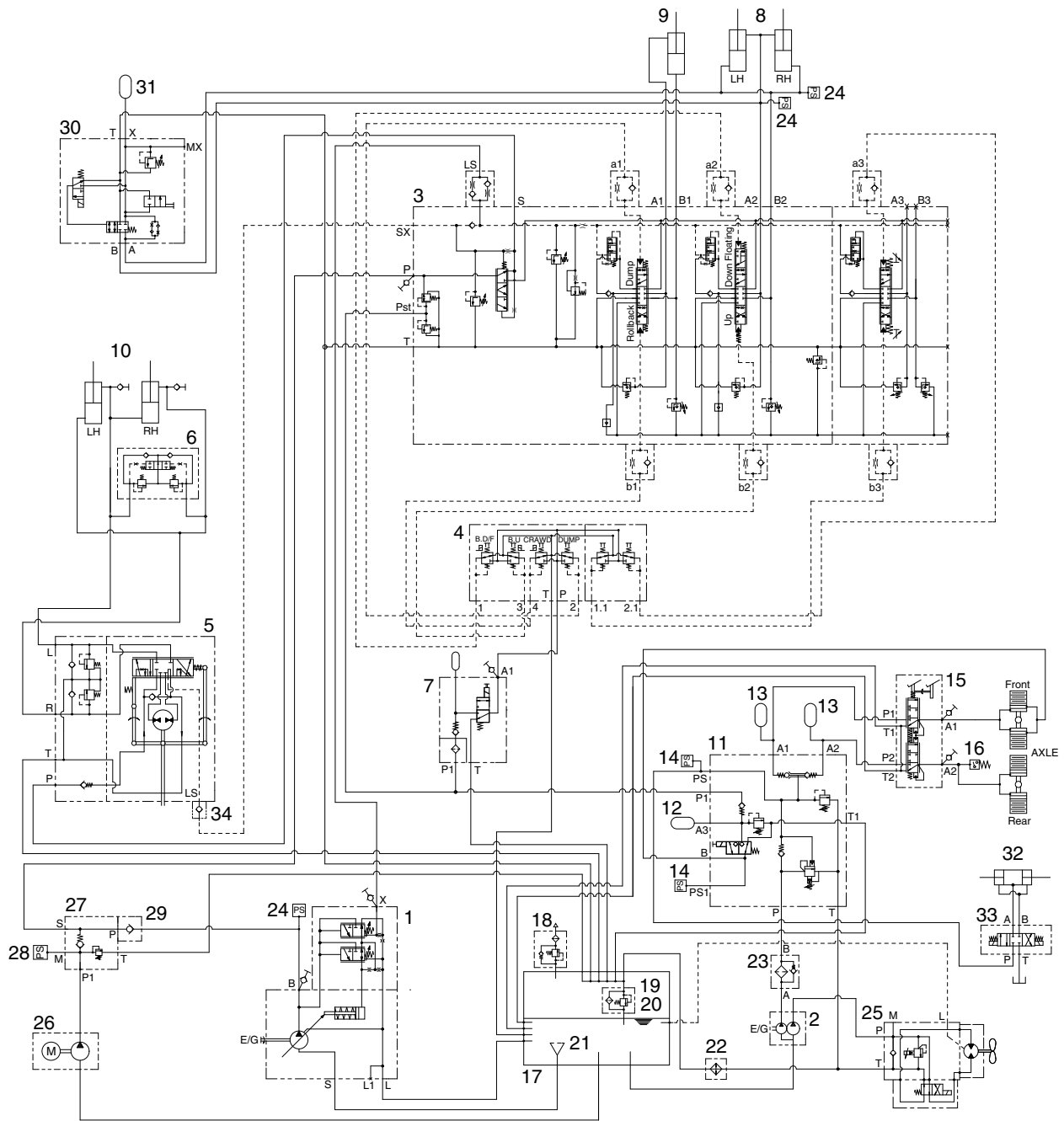

73096WE01

- | | | | | | |
|----|----------------------|----|-----------------|----|------------------------------|
| 1 | Main pump | 13 | Accumulator | 25 | Fan motor |
| 2 | Fan & brake pump | 14 | Pressure sensor | 26 | Pump motor (opt) |
| 3 | Main control valve | 15 | Brake valve | 27 | Check block (opt) |
| 4 | Remote control valve | 16 | Pressure switch | 28 | Pressure sensor (opt) |
| 5 | Steering unit | 17 | Hydraulic tank | 29 | Check valve (opt) |
| 6 | Cushion valve | 18 | Air breather | 30 | Ride control valve (opt) |
| 7 | Safety valve | 19 | Return filter | 31 | Accumulator (opt) |
| 8 | Boom cylinder | 20 | By pass valve | 32 | Quick coupler cylinder (opt) |
| 9 | Bucket cylinder | 21 | Strainer | 33 | Solenoid valve (opt) |
| 10 | Steering cylinder | 22 | Oil cooler | 34 | Check valve |
| 11 | Cut-off valve | 23 | Pressure filter | | |
| 12 | Accumulator | 24 | Pressure sensor | | |

HYDRAULIC CIRCUIT (HL730-9, HL730XTD-9, #0236~)

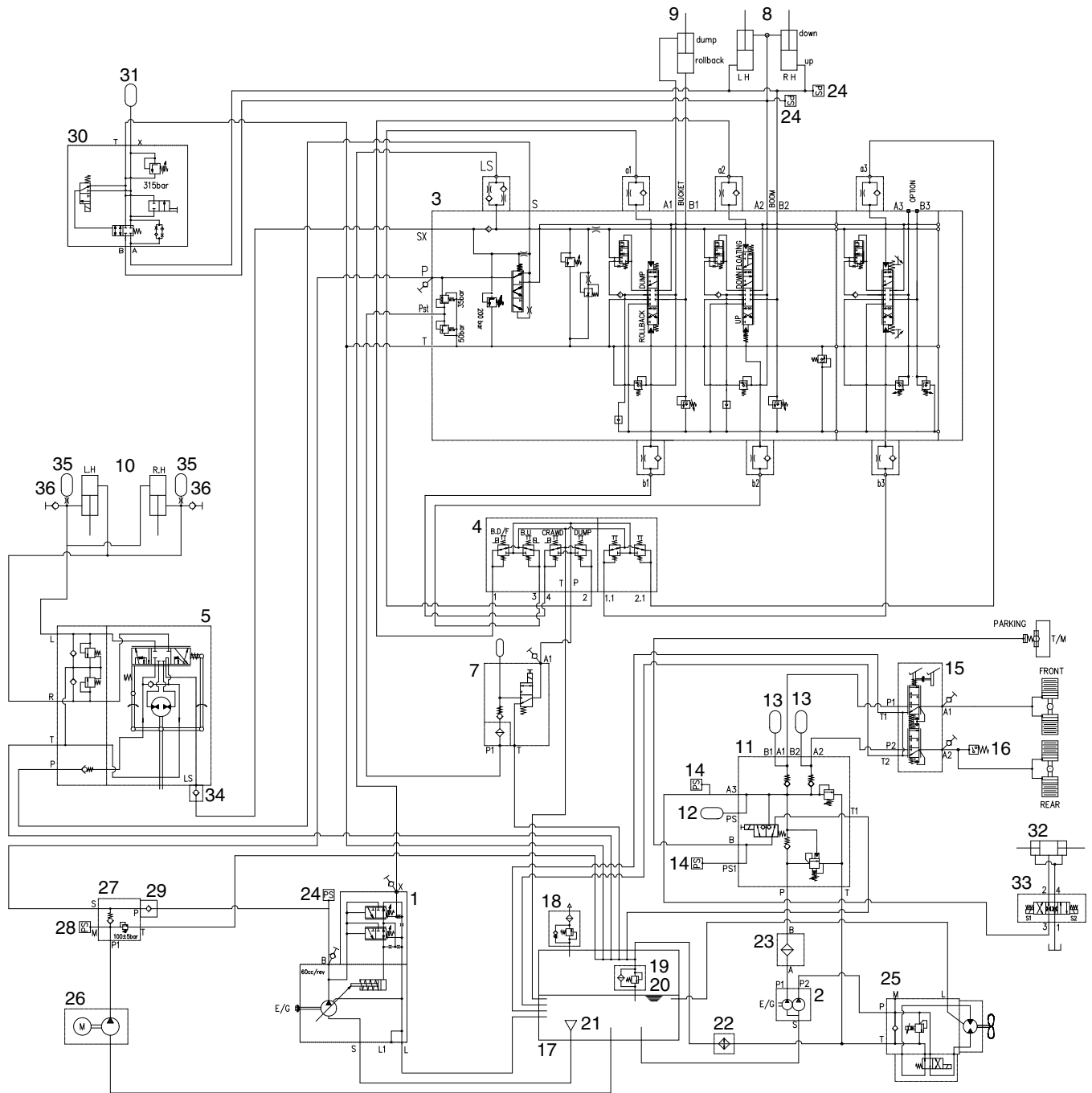

73096WE01A

- | | | | | | |
|----|----------------------|----|-----------------|----|------------------------------|
| 1 | Main pump | 14 | Pressure sensor | 26 | Pump motor (opt) |
| 2 | Fan & brake pump | 15 | Brake valve | 27 | Check block (opt) |
| 3 | Main control valve | 16 | Pressure switch | 28 | Pressure sensor (opt) |
| 4 | Remote control valve | 17 | Hydraulic tank | 29 | Check valve (opt) |
| 5 | Steering unit | 18 | Air breather | 30 | Ride control valve (opt) |
| 7 | Safety valve | 19 | Return filter | 31 | Accumulator (opt) |
| 8 | Boom cylinder | 20 | By pass valve | 32 | Quick coupler cylinder (opt) |
| 9 | Bucket cylinder | 21 | Strainer | 33 | Solenoid valve (opt) |
| 10 | Steering cylinder | 22 | Oil cooler | 34 | Check valve |
| 11 | Cut-off valve | 23 | Pressure filter | 35 | Accumulator |
| 12 | Accumulator | 24 | Pressure sensor | 36 | Orifice |
| 13 | Accumulator | 25 | Fan motor | | |

HYDRAULIC CIRCUIT (HL730TM-9, ~#0085)

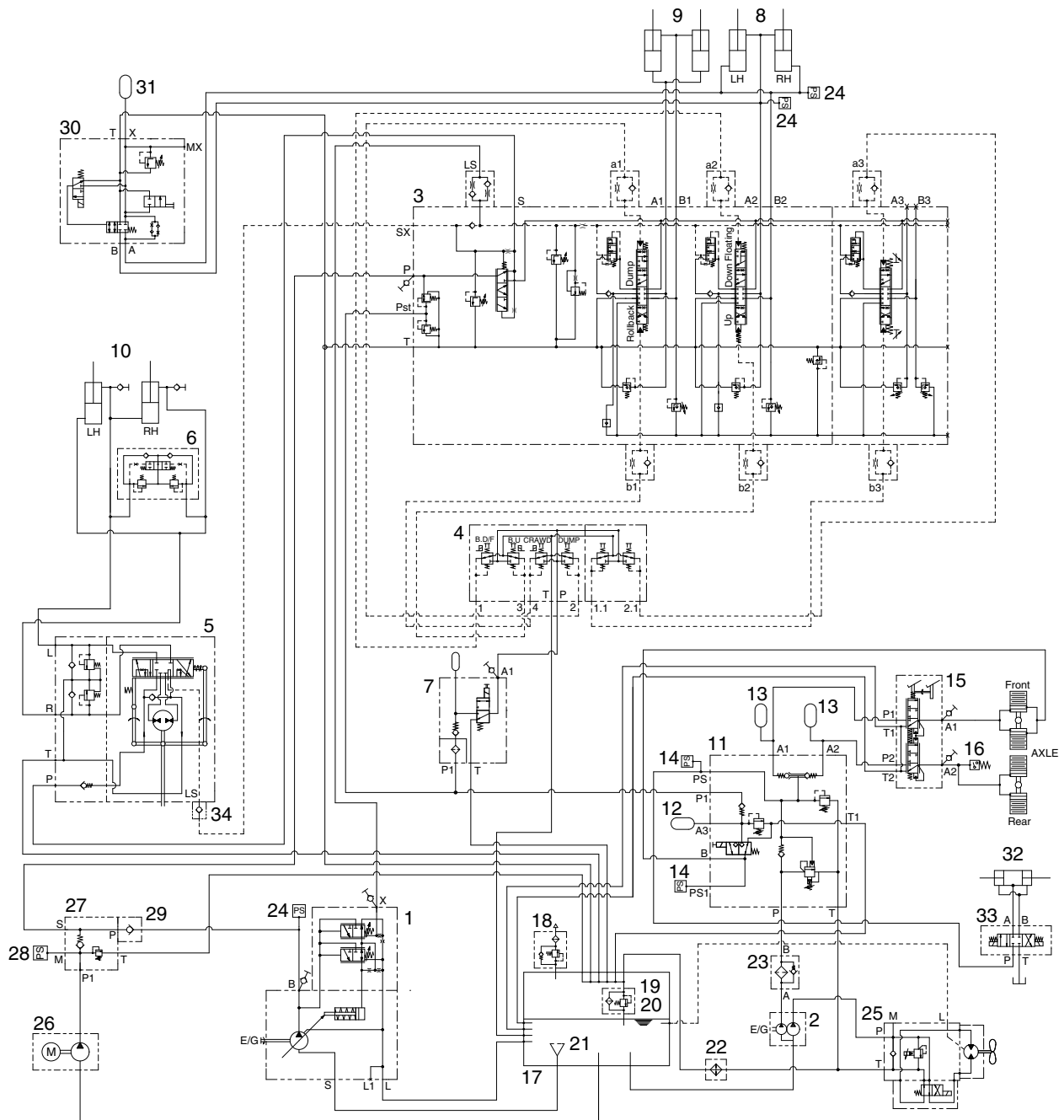

730TM96WE01

- | | | |
|------------------------|--------------------|---------------------------------|
| 1 Main pump | 13 Accumulator | 25 Fan motor |
| 2 Fan & brake pump | 14 Pressure sensor | 26 Pump motor (opt) |
| 3 Main control valve | 15 Brake valve | 27 Check block (opt) |
| 4 Remote control valve | 16 Pressure switch | 28 Pressure sensor (opt) |
| 5 Steering unit | 17 Hydraulic tank | 29 Check valve (opt) |
| 6 Cushion valve | 18 Air breather | 30 Ride control valve (opt) |
| 7 Safety valve | 19 Return filter | 31 Accumulator (opt) |
| 8 Boom cylinder | 20 By pass valve | 32 Quick coupler cylinder (opt) |
| 9 Bucket cylinder | 21 Strainer | 33 Solenoid valve (opt) |
| 10 Steering cylinder | 22 Oil cooler | 34 Check valve |
| 11 Cut-off valve | 23 Pressure filter | |
| 12 Accumulator | 24 Pressure sensor | |

HYDRAULIC CIRCUIT (HL730TM-9, #0086~)

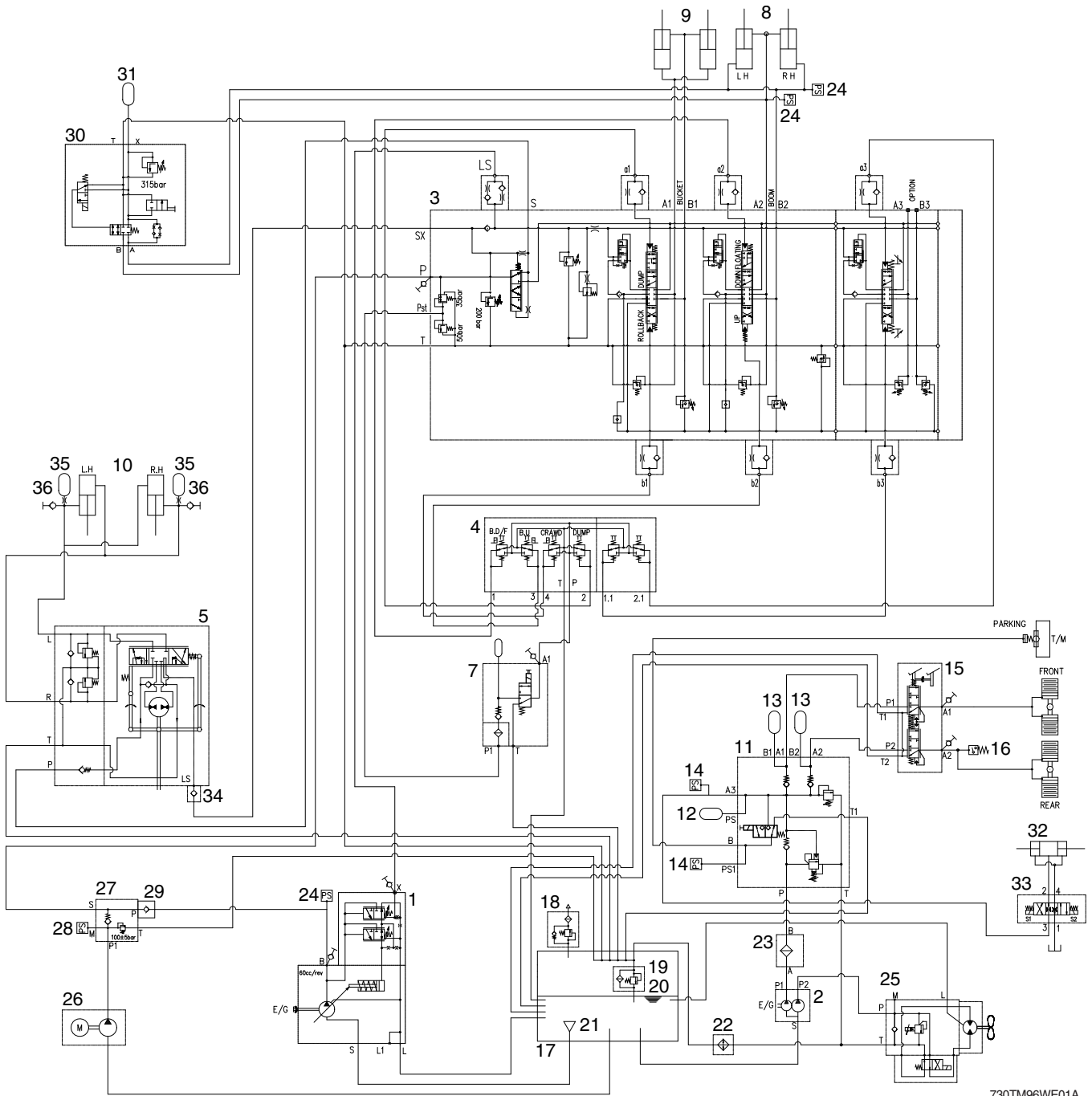

- | | | | | | |
|----|----------------------|----|-----------------|----|------------------------------|
| 1 | Main pump | 14 | Pressure sensor | 26 | Pump motor (opt) |
| 2 | Fan & brake pump | 15 | Brake valve | 27 | Check block (opt) |
| 3 | Main control valve | 16 | Pressure switch | 28 | Pressure sensor (opt) |
| 4 | Remote control valve | 17 | Hydraulic tank | 29 | Check valve (opt) |
| 5 | Steering unit | 18 | Air breather | 30 | Ride control valve (opt) |
| 7 | Safety valve | 19 | Return filter | 31 | Accumulator (opt) |
| 8 | Boom cylinder | 20 | By pass valve | 32 | Quick coupler cylinder (opt) |
| 9 | Bucket cylinder | 21 | Strainer | 33 | Solenoid valve (opt) |
| 10 | Steering cylinder | 22 | Oil cooler | 34 | Check valve |
| 11 | Cut-off valve | 23 | Pressure filter | 35 | Accumulator |
| 12 | Accumulator | 24 | Pressure sensor | 36 | Orifice |
| 13 | Accumulator | 25 | Fan motor | | |

3. WORK EQUIPMENT HYDRAULIC CIRCUIT

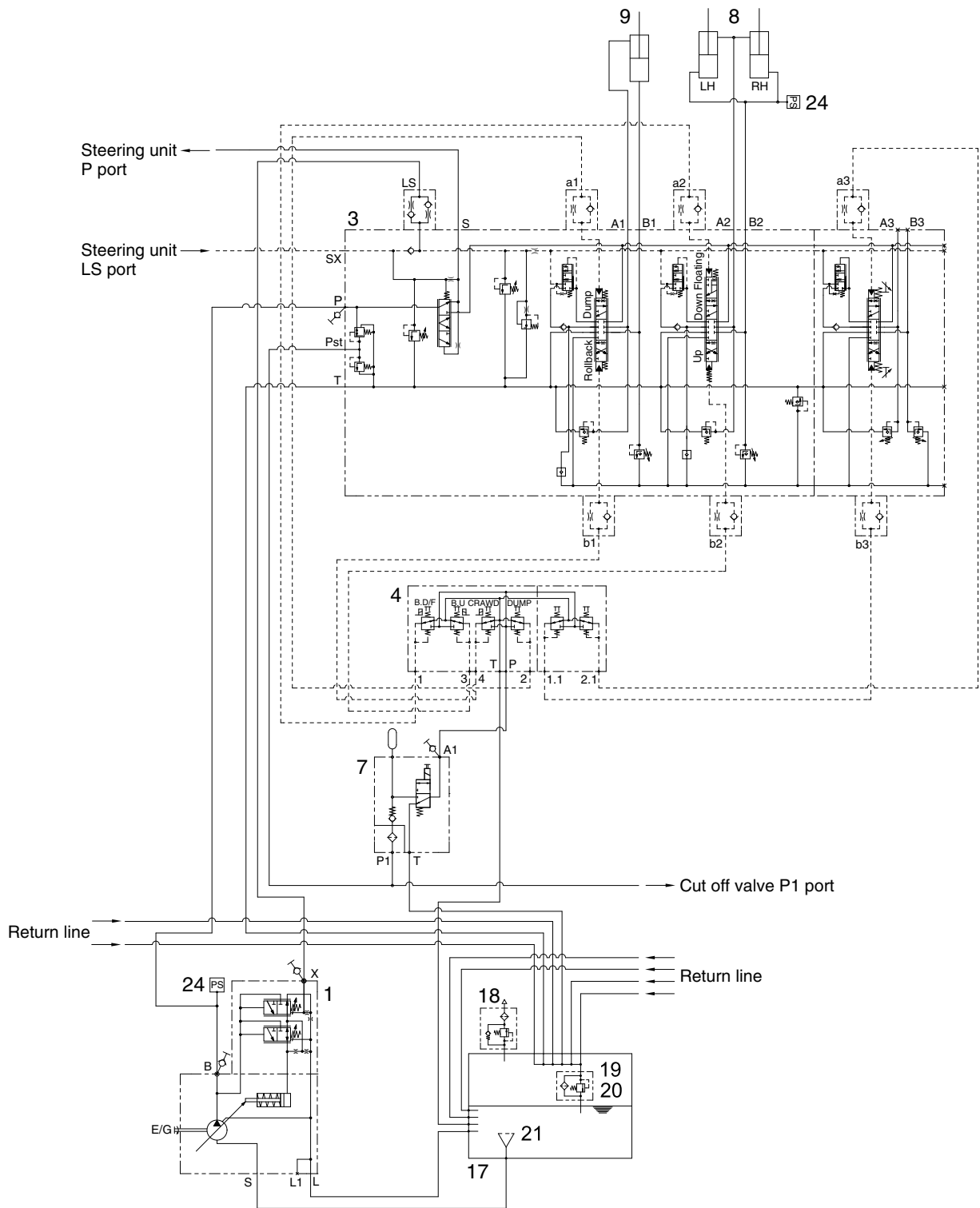

73096WE02

- | | | | | | |
|---|----------------------|----|-----------------|----|-----------------|
| 1 | Main pump | 8 | Boom cylinder | 19 | Return filter |
| 3 | Main control valve | 9 | Bucket cylinder | 20 | Bypass valve |
| 4 | Remote control valve | 17 | Hydraulic tank | 21 | Strainer |
| 7 | Safety valve | 18 | Air breather | 24 | Pressure sensor |

1) WHEN THE RCV LEVER IS IN THE RAISE POSITION

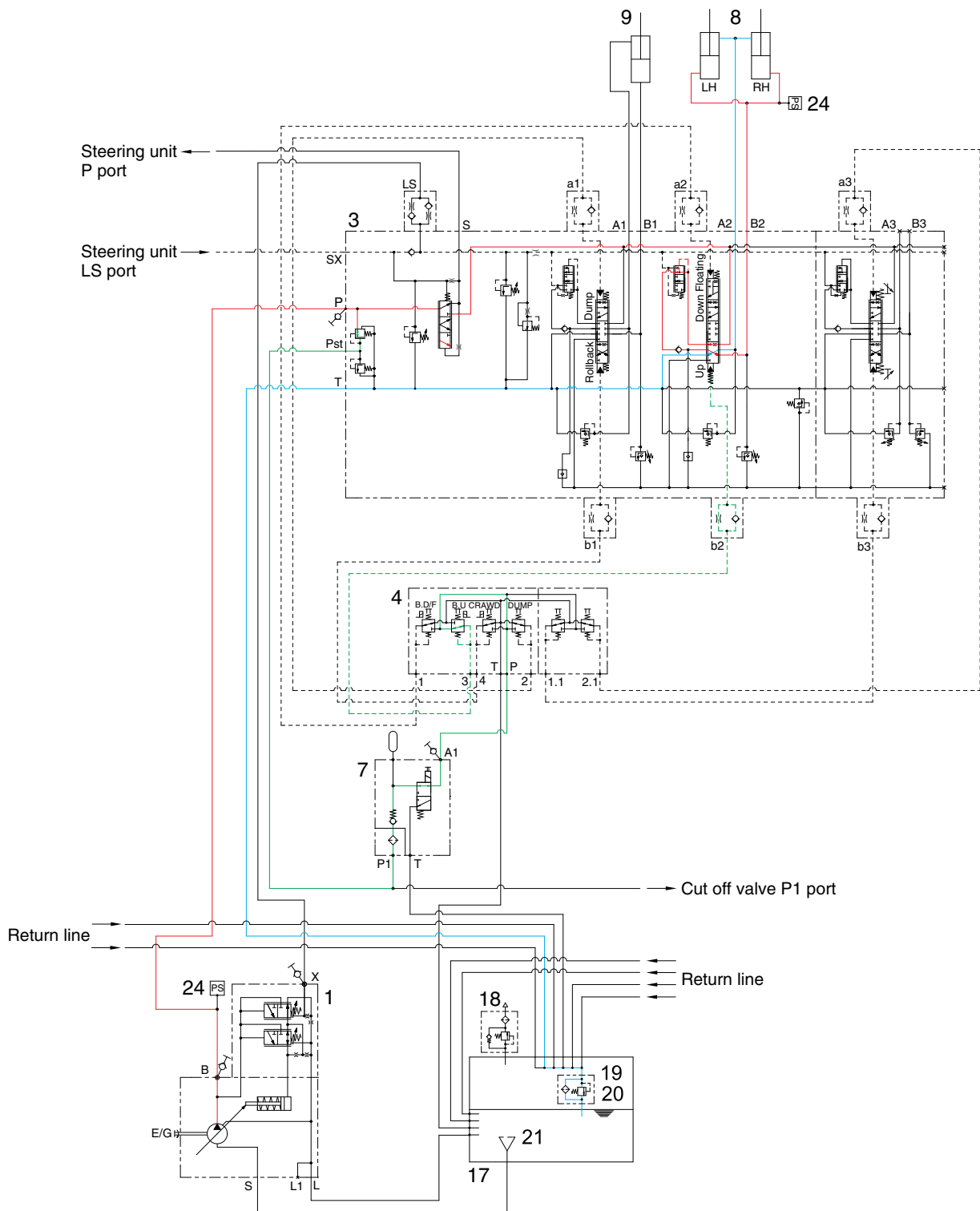

73096WE03

- When the RCV lever (4) is pulled back, the boom spool is moved to raise position by pilot oil pressure from port 3 of RCV.
- The oil from main pump (1) flows into main control valve (3) and then goes to the large chamber of boom cylinder (8) by pushing the load check valve of the boom spool.
- The oil from the small chamber of boom cylinder (8) returns to hydraulic oil tank (17) through the boom spool at the same time.
- When this happens, the boom goes up.

2) WHEN THE RCV LEVER IS IN THE LOWER POSITION

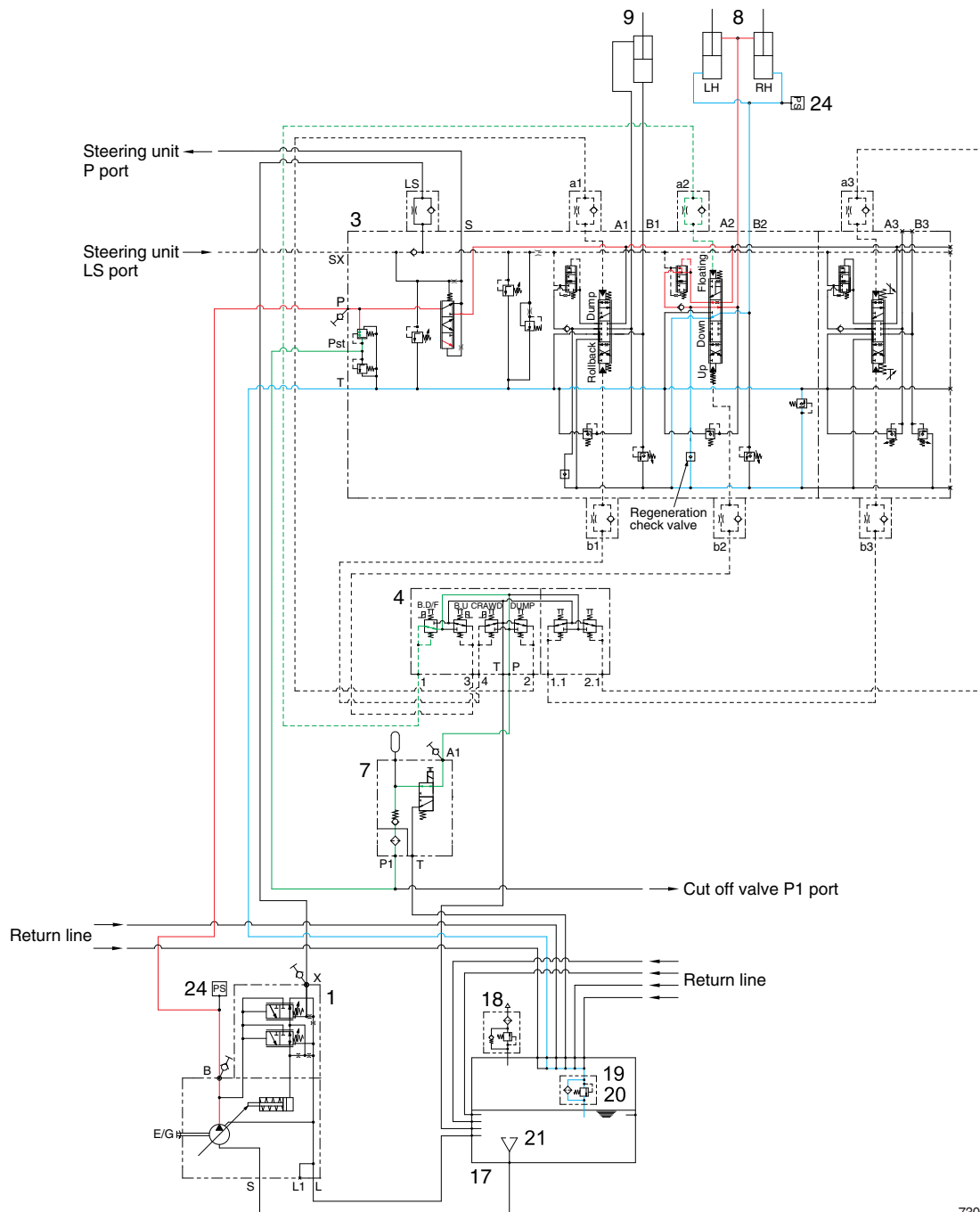

73096WE04

- When the RCV lever (4) is pushed forward, the boom spool is moved to lower position by pilot pressure.
- The oil from main pump (1) flows into main control valve (3) and then goes to small chamber of boom cylinder (8) by pushing the load check valve of the boom spool.
- The oil returned from large chamber of boom cylinder (8) returns to hydraulic tank (17) through the boom spool at the same time.
- When the lowering speed of boom is faster, the return oil from the large chamber of boom cylinder combines with the oil from the pump through the regeneration check valve, and flows into the small chamber of the cylinder.

This prevents cylinder cavitation by the negative pressure when the pump flow cannot match the boom down speed.

3) WHEN THE RCV LEVER IS IN THE FLOAT POSITION

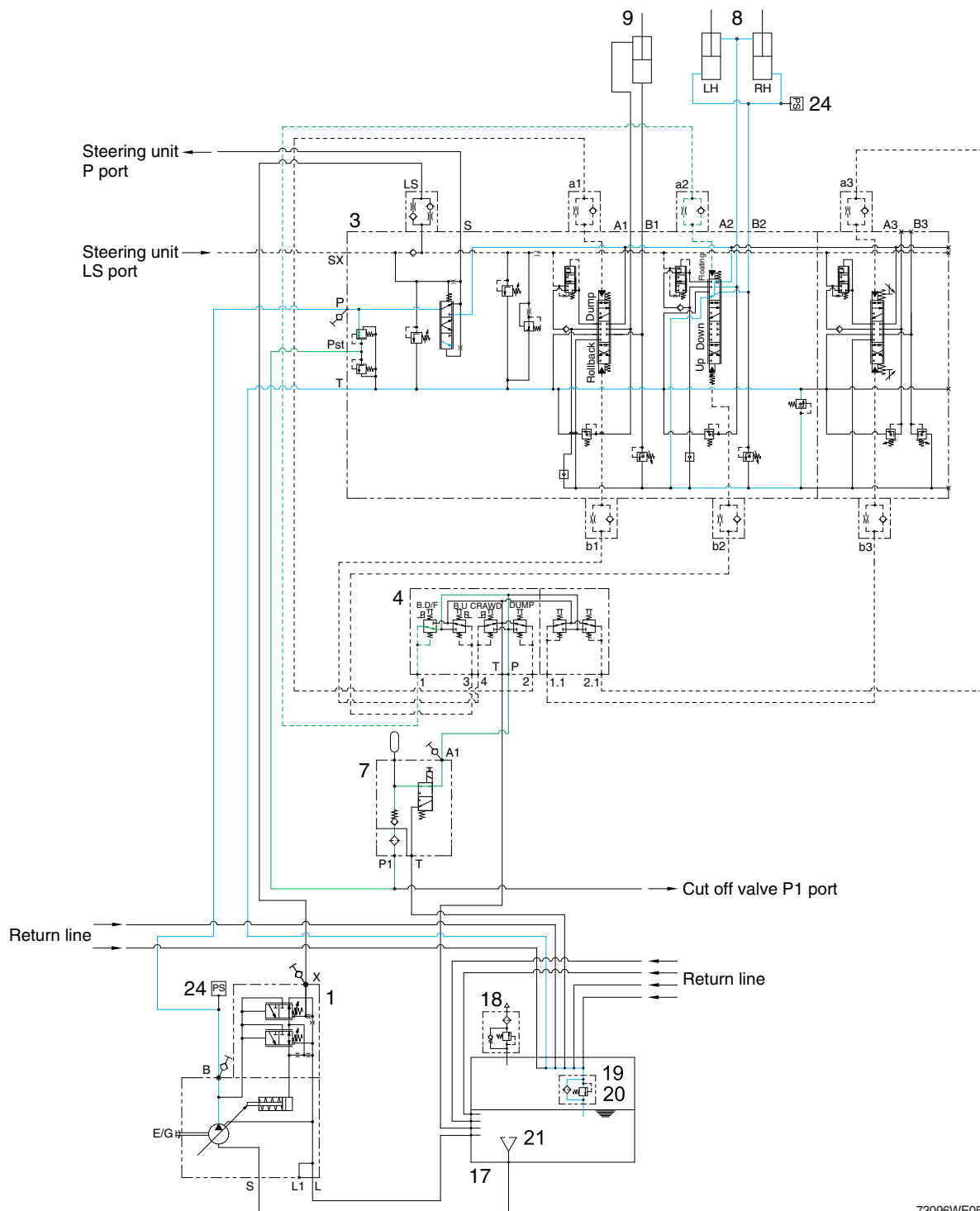

73096WE05

- When the RCV lever (4) is pushed further forward from the lower position, the pilot pressure reaches to 30bar, then the boom spool is moved to floating position.
- The work ports (A2), (B2) and the small chamber and the large chamber are connected to the return passage, so the boom will be lowered due to it's own weight.
- In this condition, when the bucket is in contact with the ground, it can be move up and down in accordance with the shape of the ground.

4) WHEN THE RCV LEVER IS IN THE DUMP POSITION

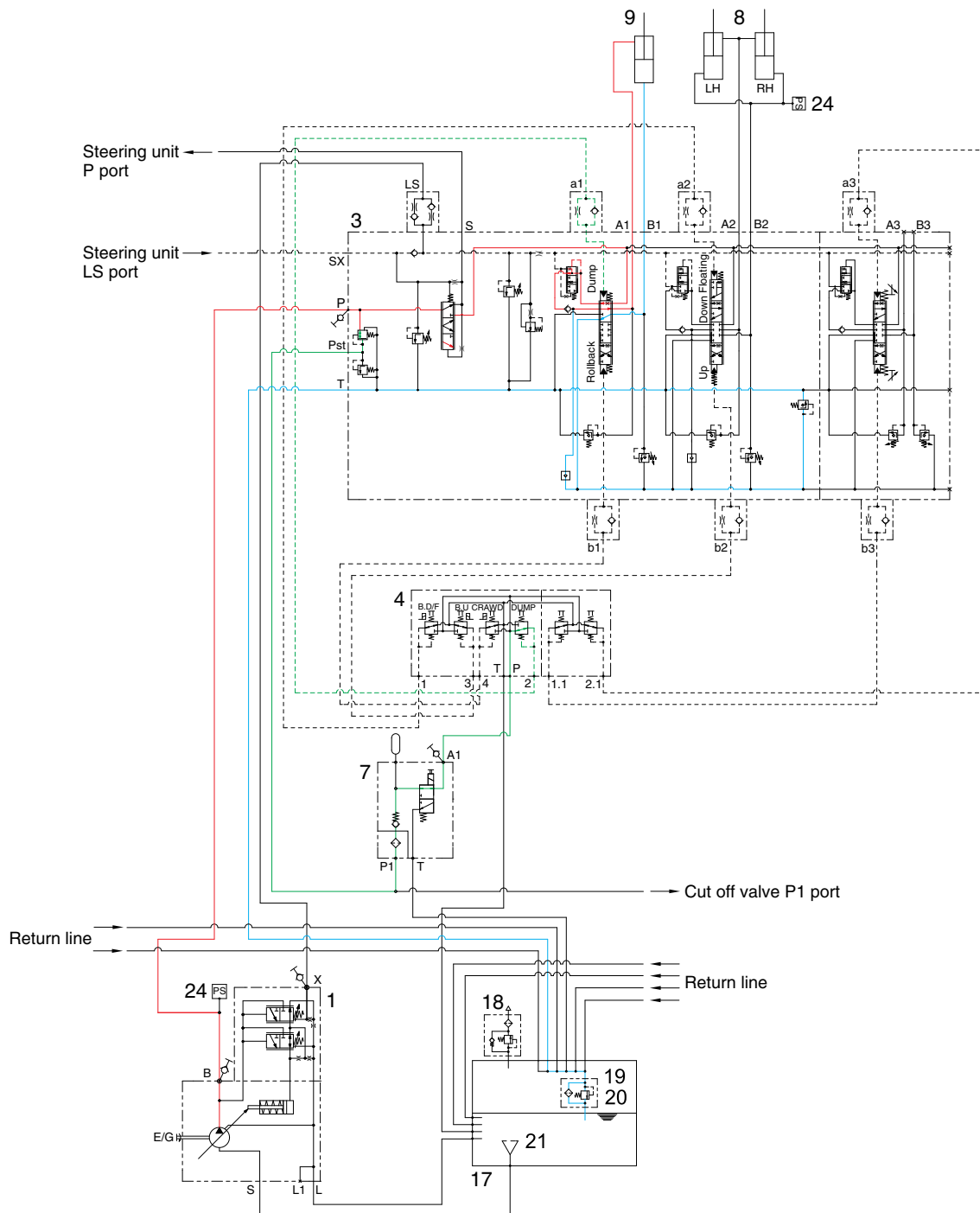

73096WE06

- If the RCV lever (4) is pushed right, the bucket spool is moved to dump position by pilot oil pressure from port 2 of RCV.
- The oil from main pump (1) flows into main control valve (3) and then goes to the small chamber of bucket cylinder (9) by pushing the load check valve of the bucket spool.
- The oil at the large chamber of bucket cylinder (9) returns to hydraulic tank (17).
- When this happens, the bucket is dumped.
- When the dumping speed of bucket is faster, the oil returned from the large chamber of bucket cylinder combines with the oil from the pump, and flows into the small chamber of the cylinder. This prevents cylinder cavitation by the negative pressure when the pump flow cannot match the bucket dump speed.

5) WHEN THE RCV LEVER IS IN THE ROLL BACK (retract) POSITION

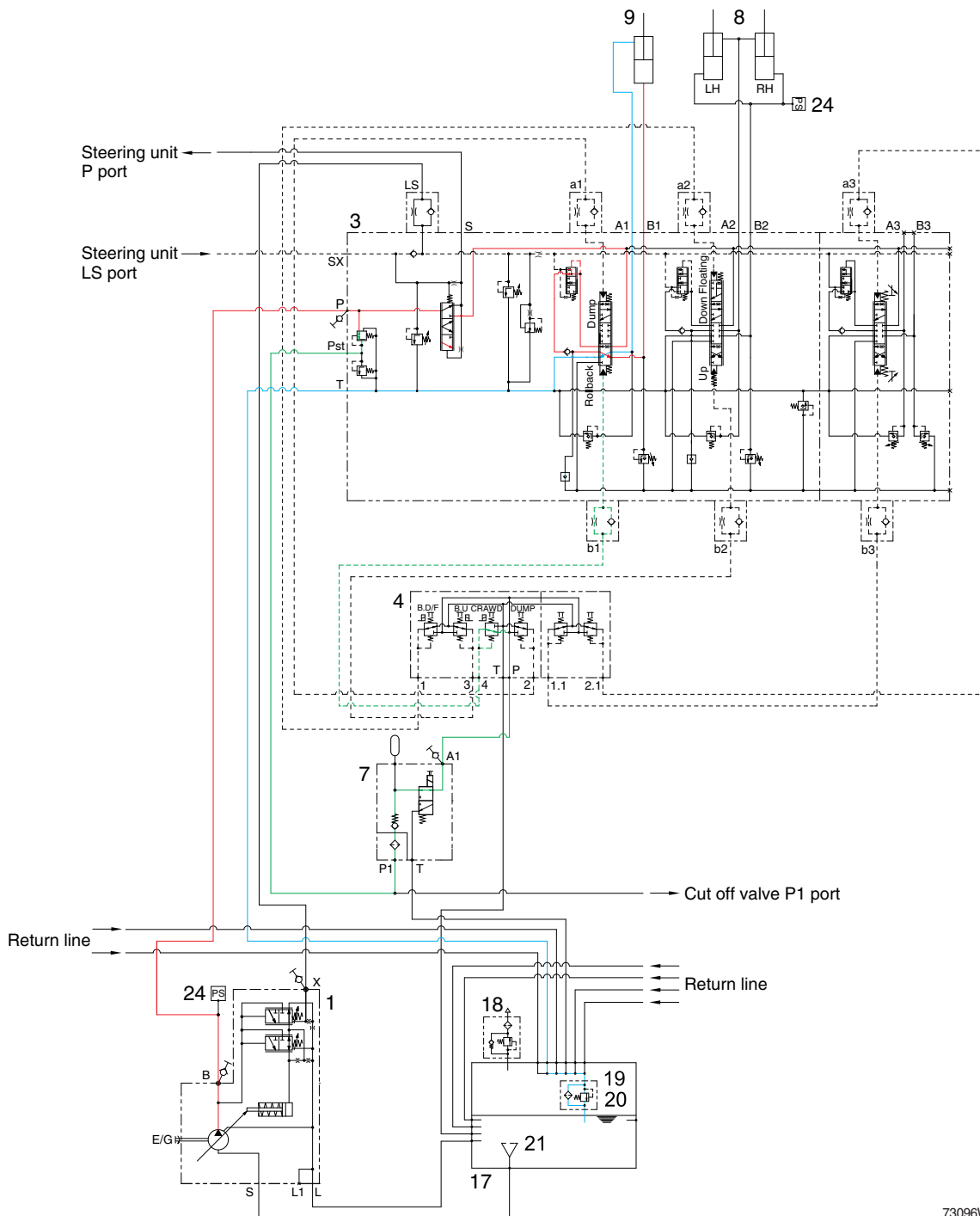

73096WE07

- If the RCV lever (4) is pulled left, the bucket spool is moved to roll back position by pilot oil pressure from port 4 of RCV.
- The oil from main pump (1) flows into main control valve (3) and then goes to the large chamber of bucket cylinder by pushing the load check valve of the bucket spool.
- The oil at the chamber of bucket cylinder (9) returns to hydraulic tank (17).
- When this happens, the bucket roll back.
- When the rolling speed of bucket is faster, the return oil from the small chamber of bucket cylinder combines with the oil from the pump, and flows into the large chamber of the cylinder. This prevents cylinder cavitation by the negative pressure when the pump flow cannot match the bucket rolling speed.

4. MAIN PUMP

1) STRUCTURE (1/2)

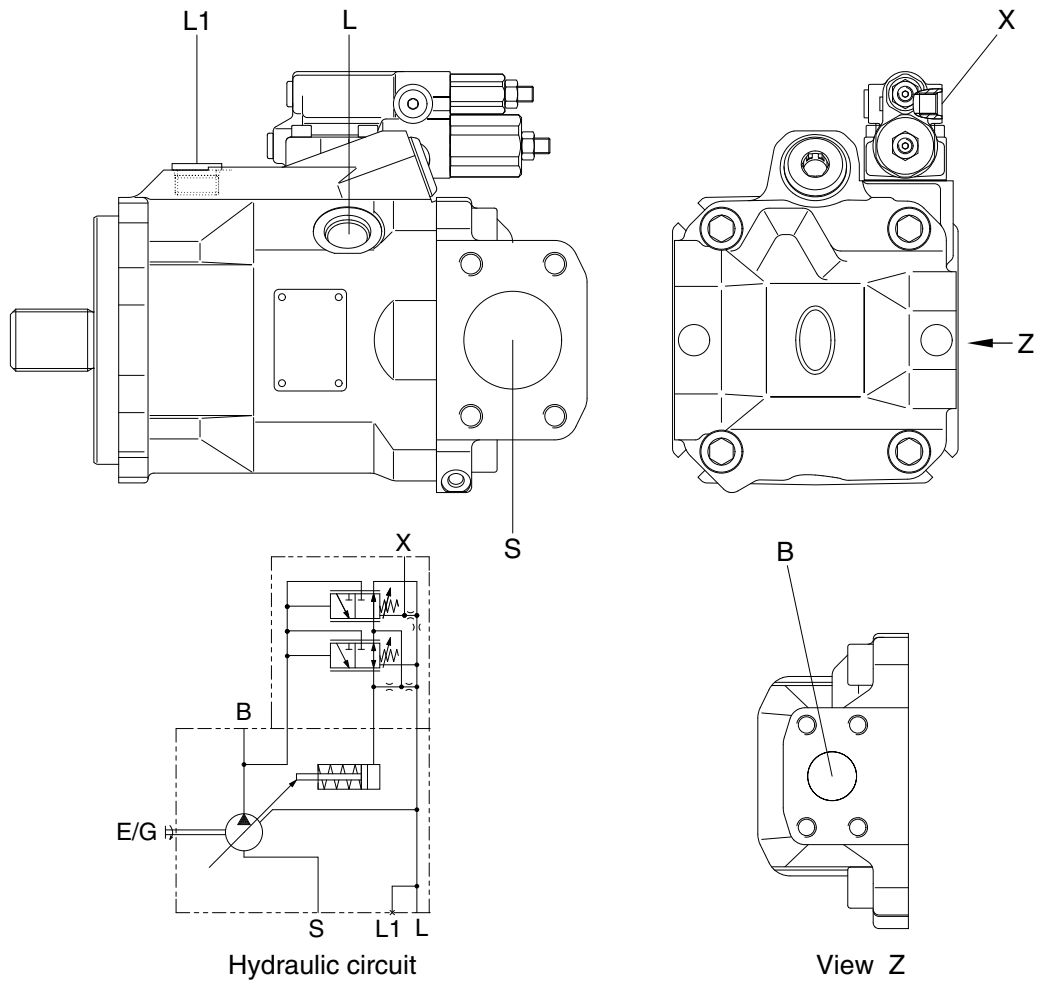

73096WE12

Port	Port name	Port size
B	Pressure port	SAE 1"
S	Suction port	SAE 2"
L, L1	Case drain port	7/8-14UNF
X	Pilot pressure port	7/16-20UNF

STRUCTURE (2/2)

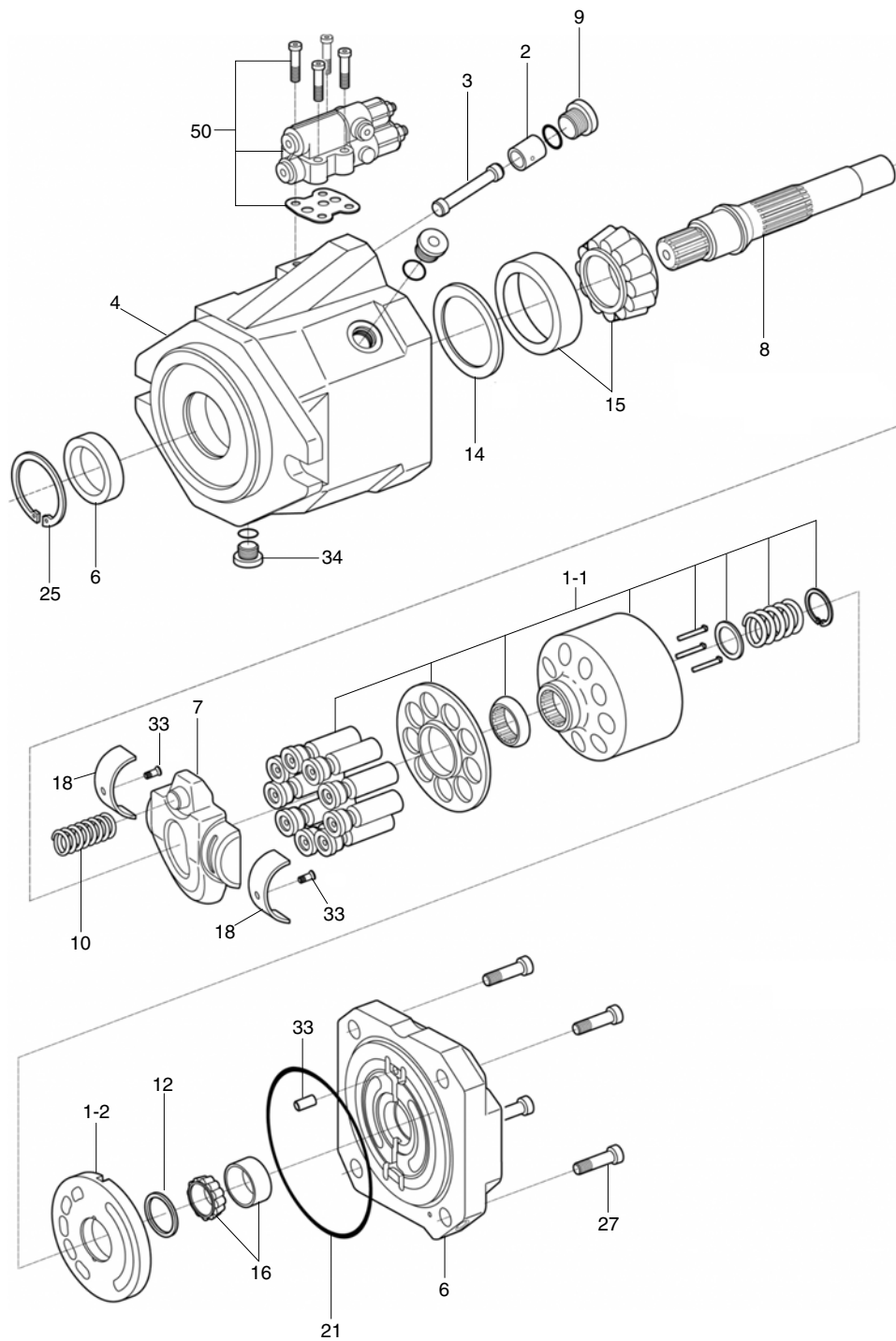

- | | | | | | |
|-----|-------------------------|----|----------------------|----|-----------------|
| 1 | Rotary group | 8 | Drive shaft | 18 | Bearing liner |
| 1-1 | High speed rotary group | 9 | Locking screw | 21 | O-ring |
| 1-2 | Control plate | 10 | Spring | 25 | Retaining ring |
| 2 | Control piston | 12 | Adjustment shim | 27 | Socket screw |
| 3 | Piston rod | 14 | Stop ring | 33 | Cylinder pin |
| 4 | Pump housing | 15 | Taper roller bearing | 34 | Locking screw |
| 6 | Shaft seal | 16 | Taper roller bearing | 40 | Flat head screw |
| 7 | Swash plate | 17 | Bearing liner | 50 | Control valve |

73096WE11

2) FUNCTION

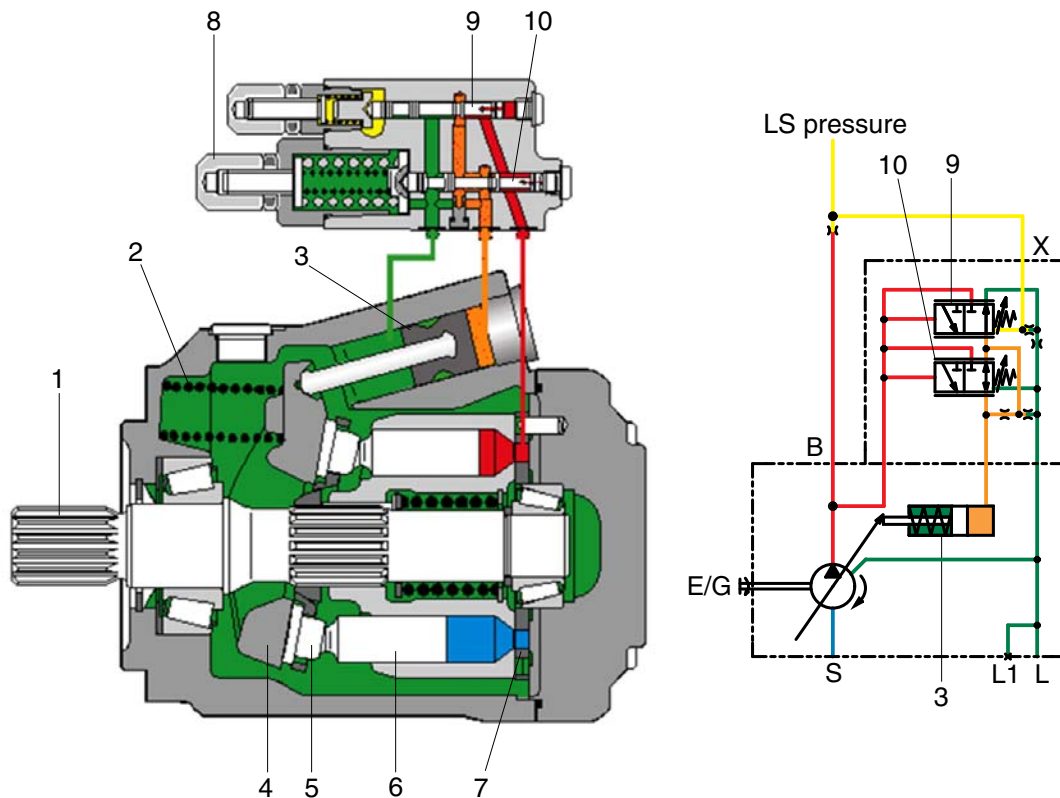

73096WE33

- | | | | |
|---|----------------|----|-------------------------------------|
| 1 | Drive shaft | 6 | Cylinder |
| 2 | Counter spring | 7 | Control plate |
| 3 | Counter piston | 8 | Pressure and flow compensator valve |
| 4 | Swash plate | 9 | Flow compensator valve |
| 5 | Piston shoe | 10 | Pressure compensator valve |

The main pump is variable piston pump. The main pump is flow controlled by LS signal. When the steering or loader are not being used, the pumps are at low pressure standby.

The load sensing pressure that is sensed from hydraulic systems flow to flow compensator valve (9). This spool keeps the pump output at a level that is necessary to fulfill the requirements for the system flow and for the pressure.

The pressure compensator valve (10) also limits maximum system pressure. The pressure compensator valve (10) prevents damage to hydraulic components from excessive pressure.

The swivel angle of the pumps is controlled by counter spring (2) and control piston (3). Counter spring (2) cause swash plate (4) to move at maximum displacement or causes swash plate (4) to upstroke and control piston (3) causes swash plate (4) to destroke the pump.

Flow compensator valve (9) and/or pressure compensator valve (10) changes pump output by regulating the pump discharge pressure that is acting on control piston (3).

The oil pressure that is acting against control piston (3) overcomes the force of counter spring (2). The oil pressure then causes the pump to destroke.

Pressure and flow compensator valve (8) also controls the maximum output of pump pressure. When steering and loader pressure rises above pressure compensator setting, pressure compensator valve (10) overrides flow compensator valve (9). This causes the pump to destroke.

(1) Upstroking

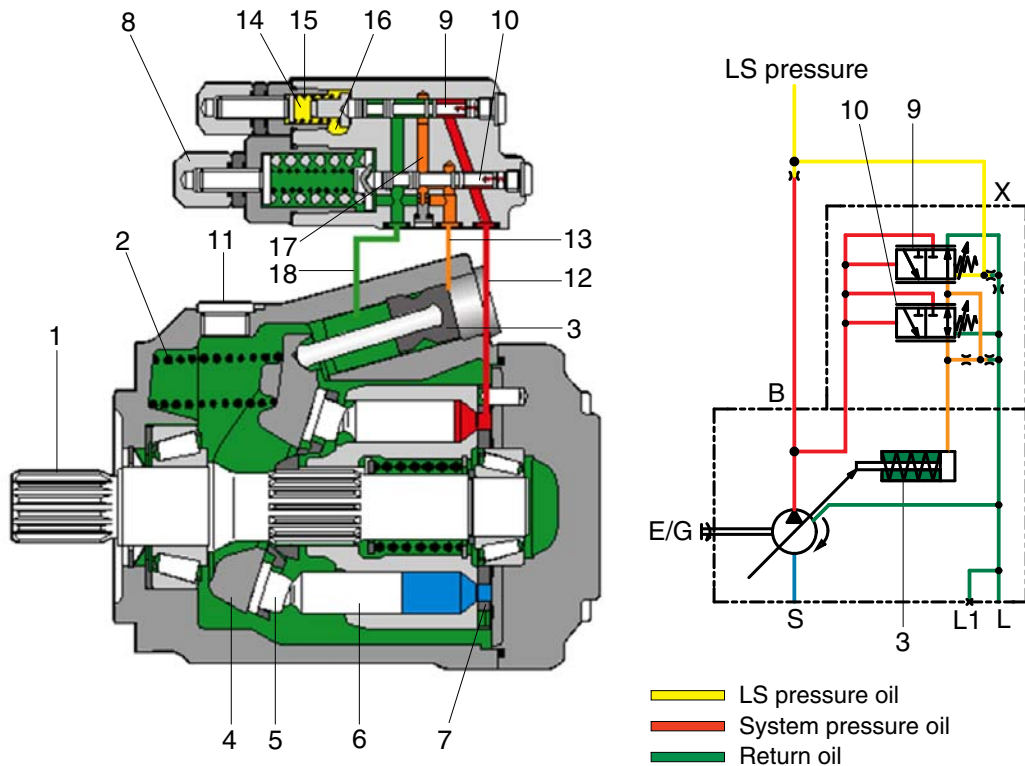

- | | | |
|------------------|---------------------------------------|------------|
| 1 Drive shaft | 8 Pressure and flow compensator valve | 14 LS line |
| 2 Counter spring | 9 Flow compensator valve | 15 Spring |
| 3 Counter piston | 10 Pressure compensator valve | 16 Cavity |
| 4 Swash plate | 11 Case drain | 17 Passage |
| 5 Piston shoe | 12 Passage | 18 Passage |
| 6 Cylinder | 13 Passage | |
| 7 Control plate | | |

73096WE34

Upstroking of the pump occurs as flow demand from loader and steering system.

The increased flow demand causes a LS pressure in LS line (14). The LS pressure in LS line (14) combines with the force of spring (15) in cavity (16).

The force of spring (15) causes pump pressure to be higher than the LS pressure (14).

If the combination of LS pressure and of spring force is greater than the pump discharge pressure, this difference pressure causes spool (9) to move right. As spool (9) moves right, the spool (9) blocks the flow of supply oil to control piston (10). Pump swash plate (4) is controlled by pressure and flow as much as hydraulic system requests.

When the oil flow to control piston (3) is blocked, the pilot oil in passage (13) drains to passage (17). The oil then flows past pressure compensator valve (10) and through passage (18) into the housing and via the drain line (11) to tank.

The force of counter spring (2) acts against swash plate (4). This causes swash plate (2) to upstroke.

This also causes the pump flow to increase. As flow requirements are satisfied, the pump output pressure increase. The pressure increases until the pressure in passage (12) moves flow compensator spool (9) up to be satisfied with system requirement for pressure and flow.

- Pump discharge pressure = force of spring (15) + LS pressure (14)

(2) Destroking

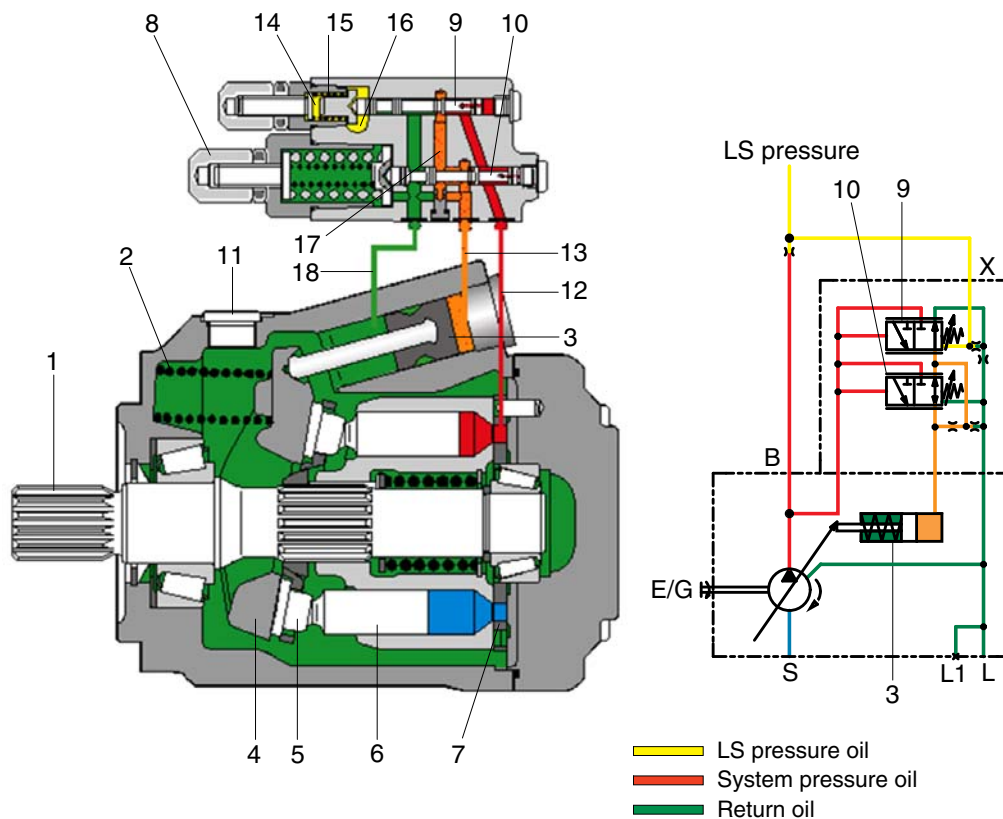

73096WE35

1 Drive shaft	8 Pressure and flow compensator valve	14 LS line
2 Counter spring	9 Flow compensator valve	15 Spring
3 Counter piston	10 Pressure compensator valve	16 Cavity
4 Swash plate	11 Case drain	17 Passage
5 Piston shoe	12 Passage	18 Passage
6 Cylinder	13 Passage	
7 Control plate		

The decreased flow demand causes a LS pressure in line (14). The LS pressure in line (14) combines with the force of spring (15) in cavity (16).

This combination of LS pressure and of spring force is less than the pump pressure in passage (12). This causes flow compensator valve (9) to move left.

Pump oil now flows through passage (12). The oil then flows past flow compensator valve (9), through passage (13), and then to control piston (3).

The pump pressure behind control piston (3) is now greater than the force of counter spring (2). The angle of swash plate (4) decreases.

This decreases the pump output and the system pressure.

When the lower flow requirements are met, flow compensator valve (9) moves right up to the balanced position. Swash plate (4) maintains an angle that is sufficient to provide the lower required pressure. If the operator does not turn the steering wheel and does not move RCV, then the pump will return to low pressure standby.

※ Control piston → Changes pump displacement ; influenced by controller.

Counter spring → Helps to change pump displacement increase.

(3) Low pressure standby

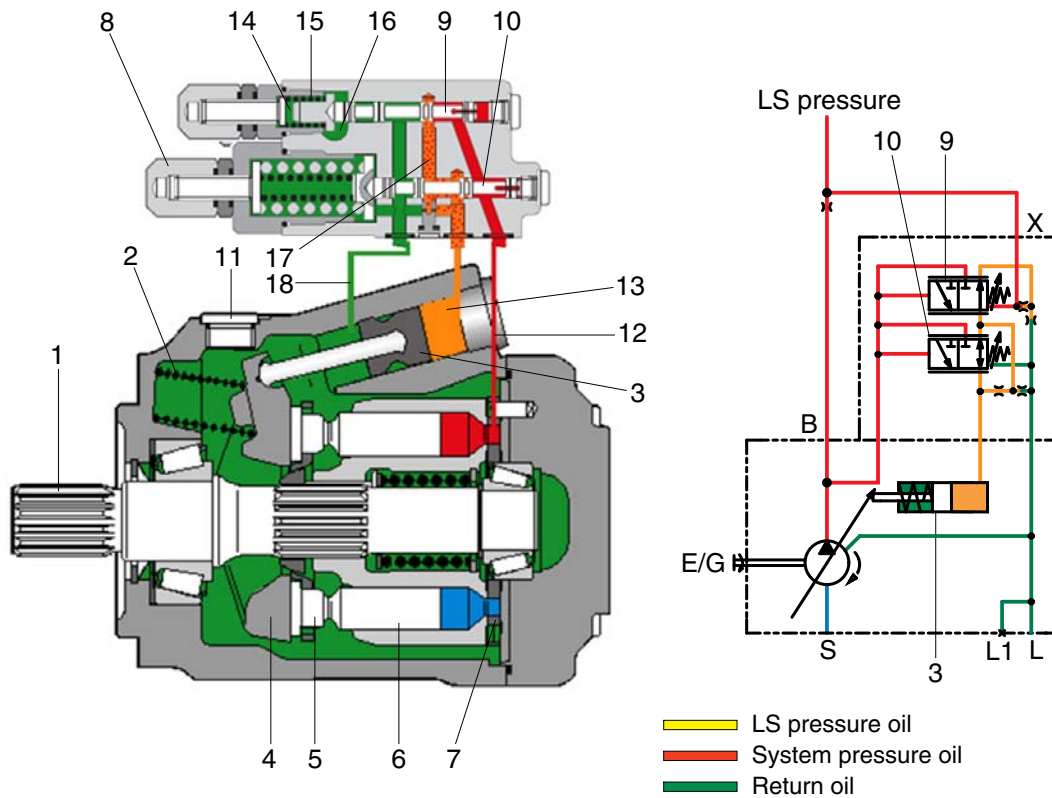

- | | | |
|------------------|---------------------------------------|------------|
| 1 Drive shaft | 8 Pressure and flow compensator valve | 14 LS line |
| 2 Counter spring | 9 Flow compensator valve | 15 Spring |
| 3 Counter piston | 10 Pressure compensator valve | 16 Cavity |
| 4 Swash plate | 11 Case drain | 17 Passage |
| 5 Piston shoe | 12 Passage | 18 Passage |
| 6 Cylinder | 13 Passage | |
| 7 Control plate | | |

73096WE36

Low pressure standby constitutes the following condition: a running engine and inactive steering and loader. There are no flow demands on the pump or pressure demands on the pump. Therefore, there is no LS pressure in line (14).

Before you start the engine, counter spring (2) holds swash plate (4) at the maximum angle. As the pump begins to turn, oil begins to flow and pressure increases in the system.

Because of close centered steering control valve and close centered loader hydraulic system.

As this pressure increase, the pressure pushes flow compensator valve (9) against spring (15). This causes flow compensator valve (9) to move left. This opens passage (17) in order to allow pressure oil to flow to control piston (3).

The oil acts against control piston (3) in order to overcome the force of counter spring (2). The oil causes control piston (3) to move to the left.

When control piston (3) moves to the left, the piston moves swash plate (4) toward the minimum angle. Control piston (3) continues to move to the left until maximum stroke of control piston (3).

The pump supplies a sufficient amount of flow that compensates for system leakage. The pump maintains low pressure standby. Low pressure standby pressure should not exceed 40 bar (580 psi).

(4) High pressure stall

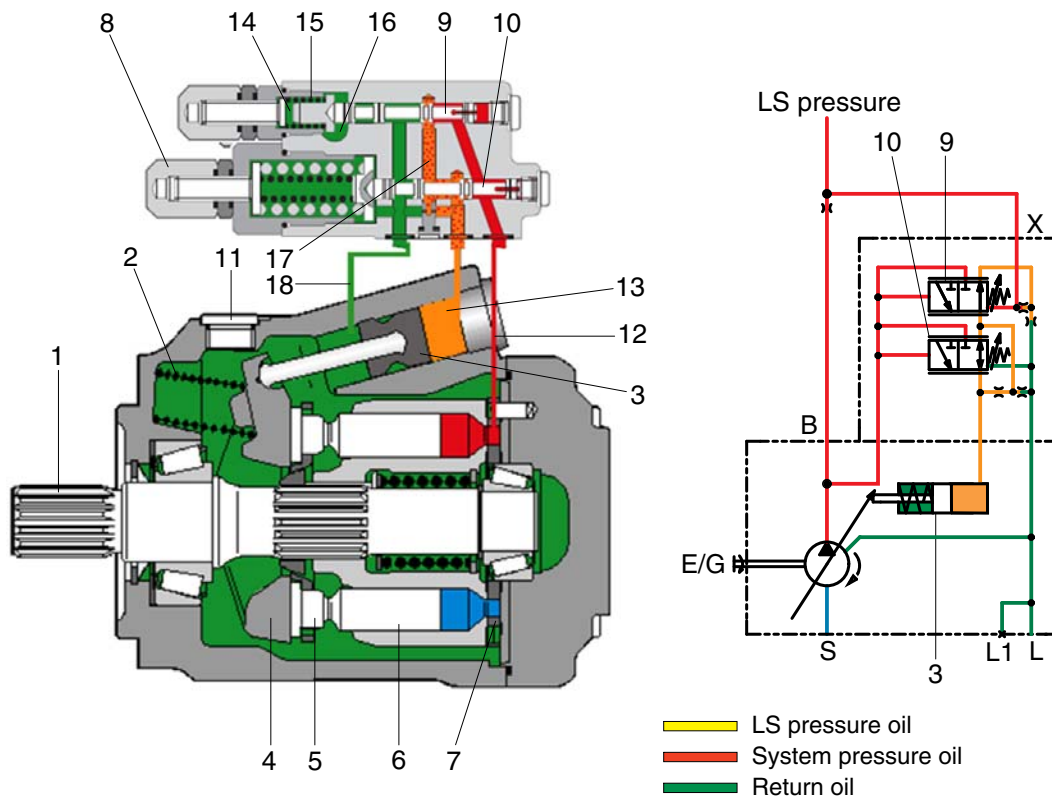

- | | | |
|------------------|---------------------------------------|------------|
| 1 Drive shaft | 8 Pressure and flow compensator valve | 14 LS line |
| 2 Counter spring | 9 Flow compensator valve | 15 Spring |
| 3 Counter piston | 10 Pressure compensator valve | 16 Cavity |
| 4 Swash plate | 11 Case drain | 17 Passage |
| 5 Piston shoe | 12 Passage | 18 Passage |
| 6 Cylinder | 13 Passage | |
| 7 Control plate | | |

When the hydraulic system stalls under load or when the cylinders reach the end of the stroke, the main system pressure increases. But LS pressure (14) is regulated by LS relief valve on steering system and loader system. The pressure difference between discharged pump and LS pressure equal to spring (15). It means no flow is necessary. Therefore, discharged pressure push flow compensator valve (9) left. Supply oil now flows past flow compensator valve (10) and through passage (17). The oil flows past flow compensator spool (9) and into passage (13). The oil then flows to control piston (3).

Pump swash plate (4) will be minimum displacement if the operator does not turn the steering wheel and RCV, then the pump will return to low pressure standby.

73096WE36

(5) Adjustment of flow control

Flow compensator setting must be carried out following procedures and conditions.

① Conditions

- Engine is running (at high or low idle).
- RCV is operated slowly (example : Boom up).
- Pressure gauges are installed.
- ※ Discharge pump flow should be less than max pump flow.

② Procedures

- Loosening the hexagon nut (2).
- Adjusting screw (1) of flow controller by tightening or loosening the screw (1).
 - Flow setting : $\Delta P = \text{Gauge A} - \text{Gauge B}$
 - Specification : 30 bar

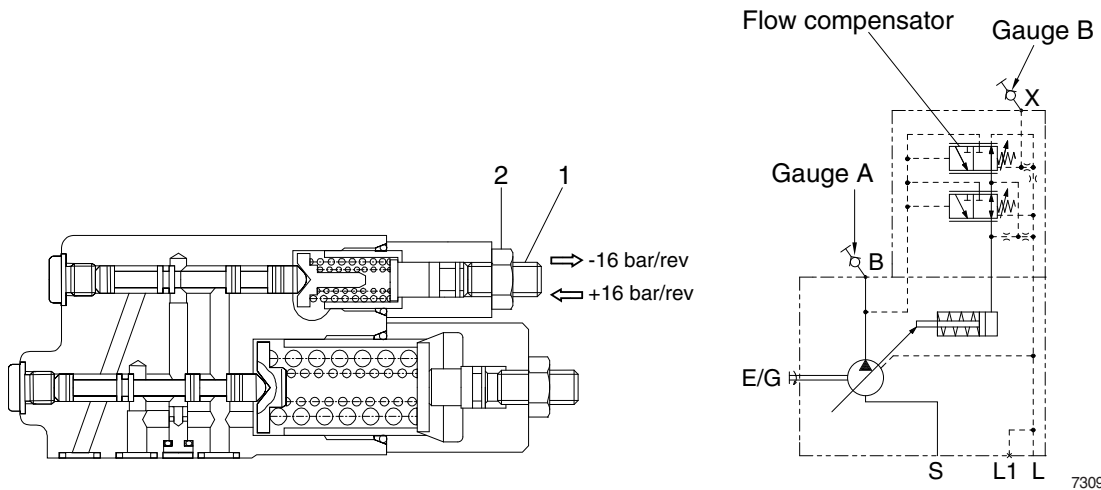

73096WE37

(6) Adjustment of pressure control

Pressure compensator setting must be carried out following procedures and conditions.

① Conditions

- Engine is running.
- System is at relief condition.

② Procedures

- Loosening the hexagon nut (2).
- Adjusting screw (1) of pressure controller by tightening or loosening the screw (1).
 - Maximum pressure setting = Gauge A
 - Specification : 270 bar

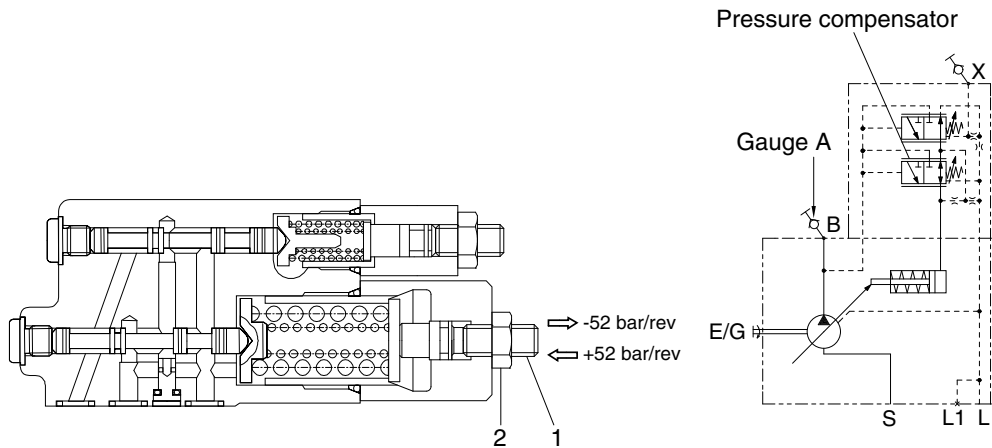

73096WE38

5. REMOTE CONTROL VALVE

1) STRUCTURE

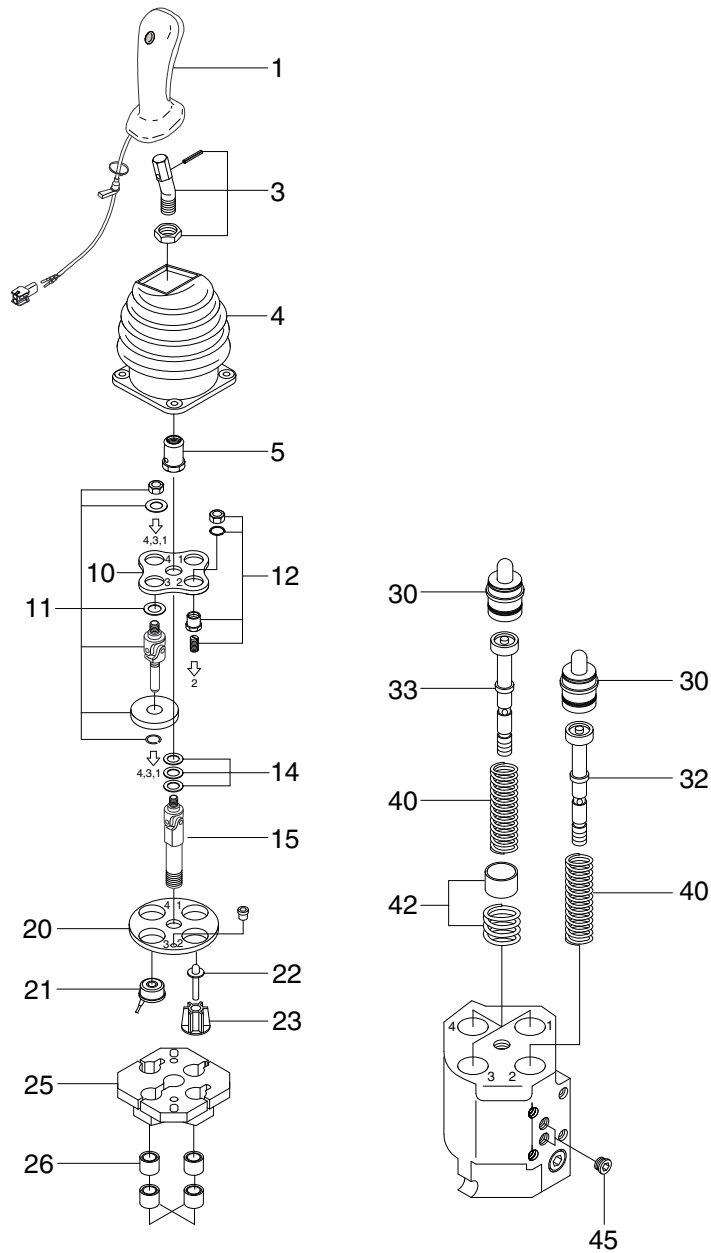

- 1 Handle
- 3 Lever kit
- 4 Bellows
- 5 Nut
- 10 Bracket
- 11 Detent kit
- 12 Plunger kit

- 14 Shim set
- 15 Joint
- 20 Flange
- 21 Solenoid complete
- 22 Plunger kit
- 23 Plunger guide
- 25 Electric bracket

- 26 Bushing kit
- 30 Plunger kit
- 32 Regulating unit
- 33 Regulating unit
- 40 Spring set
- 42 Prefeel point kit
- 45 Plug set

7707WE11

2) OPERATION

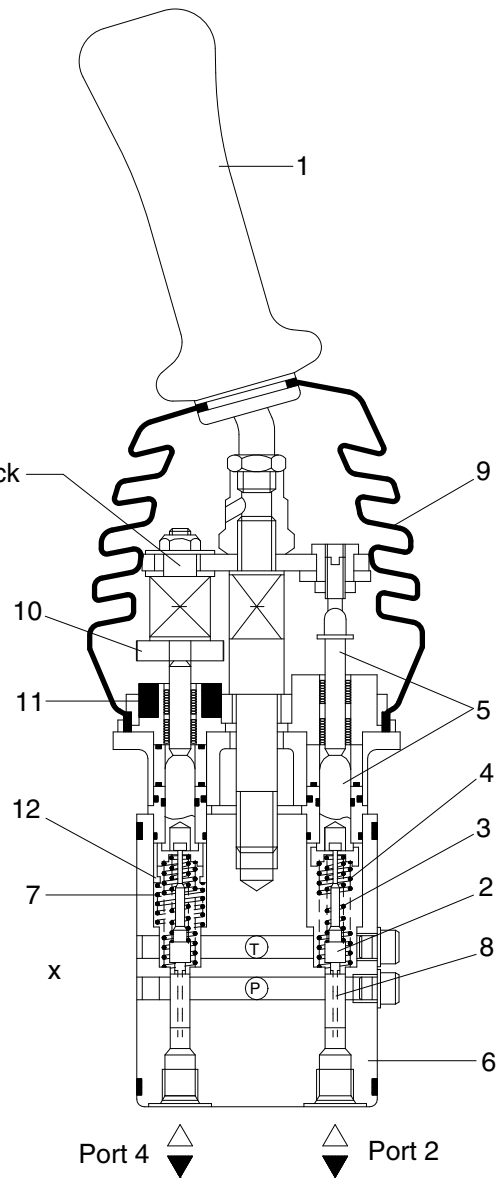
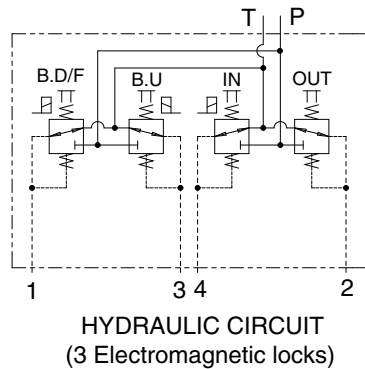

7707WE12

(1) Hydraulic functional principle

Pilot devices with end position locks operate as direct operated pressure reducing valves.

They basically comprise of control lever (1), four pressure reducing valves, housing (6) and locks.

Each pressure reducing valve comprises of a control spool (2), a control spring (3), a return spring (4) a plunger (5).

At rest, control lever (1) is held in its neutral position by return springs (4). Ports (1, 2, 3, 4) are connected to tank port T via drilling (8).

When control lever (1) is deflected, plunger (5) is pressed against return spring (4) and control spring (3).

Control spring (3) initially moves control spool (2) downwards and closes the connection between the relevant port and tank port T. At the same time the relevant port is connected to port P via drilling (8). The control phase starts as soon as control spool (2) finds its balance between the force from control spring (3) and the force, which results from the hydraulic pressure in the relevant port (ports 1, 2, 3 or 4).

Due to the interaction between control spool (2) and control spring (3) the pressure in the relevant port is proportional to the stroke of plunger (5) and hence to the position of control lever (1).

This pressure control which is dependent on the position of the control lever and the characteristics of the control spring permits the proportional hydraulic control of the main directional valves and high response valves for hydraulic pumps.

A rubber bellows (9) protects the mechanical components in the housing from contamination.

(2) End position lock

Only those control ports, for which it is necessary to hold the control lever in a deflected position are equipped with end position locks.

Electromagnetic lock

An additional spring (7), which is fitted below an additional plate (12) warns, by means of an increased force, which is required for compressing this spring, that the plunger (5) and the control lever (1) have almost reached their end position.

When this threshold is overcome, a ring (10) contacts the solenoid armature (11) ; if the solenoid is energized, then control lever (1) is held in its end position by magnetic force.

This lock is released automatically when the solenoid is deenergized.

6. MAIN CONTROL VALVE

1) STRUCTURE (1/3)

- Type : Closed center, Load pressure - Independent - Flow - Distribution

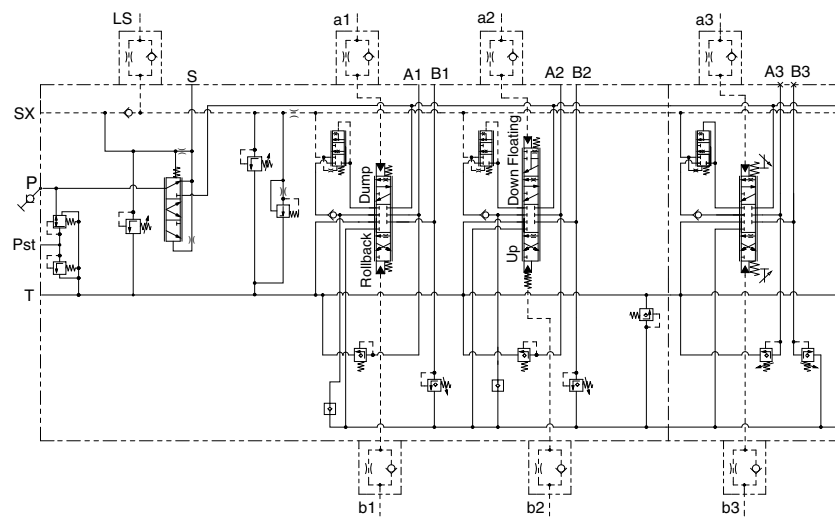
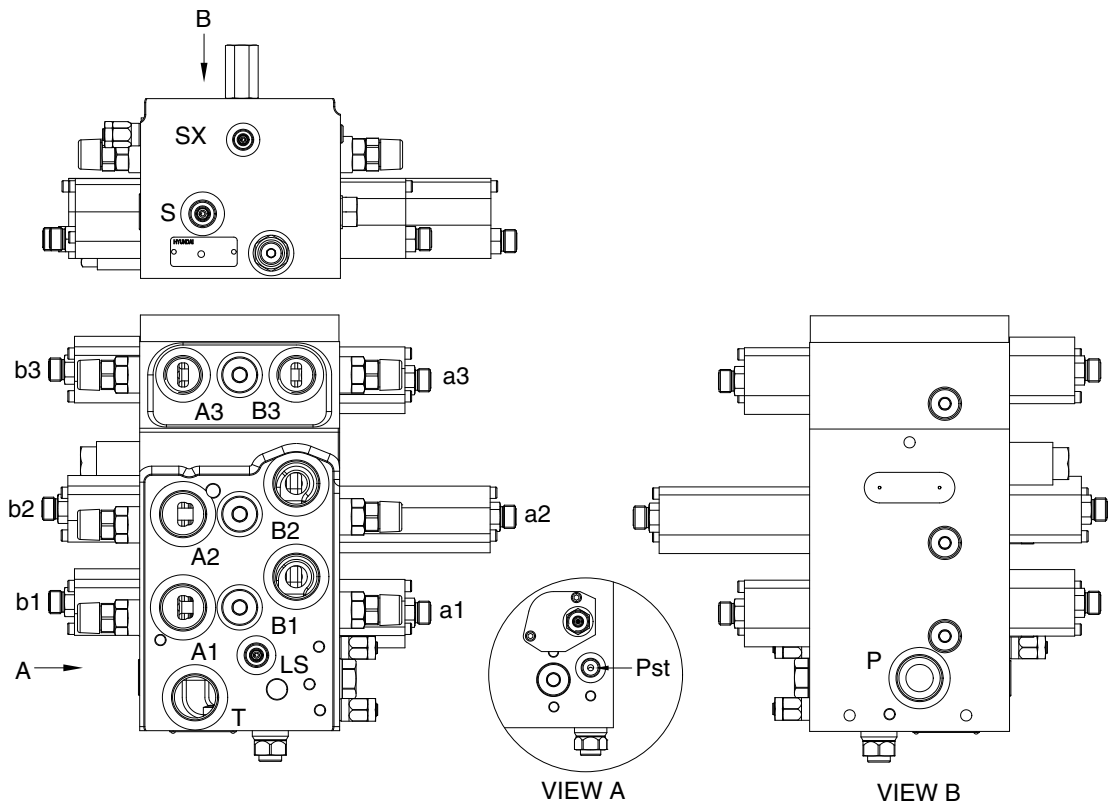

Hydraulic circuit

74096WE10

Port	Port name	Port size	Port	Port name	Port size
P	From main pump	1 5/16-12UN	a3, b3	Auxiliary pilot port	11/16-16UN
T	To hydraulic tank	1 5/16-12UN	LS	Load sensing port	9/16-18UNF
A1, B1	To bucket cylinder port	1 5/16-12UN	Pst	To RCV P port	9/16-18UNF
A2, B2	To boom cylinder port	1 5/16-12UN	SX	To steering unit LS port	9/16-18UNF
a1, b1	Bucket pilot port	11/16-16UN	S	To steering unit P port	7/8-14UNF
a2, b2	Boom pilot port	11/16-16UN	-	-	-

STRUCTURE (2/3)

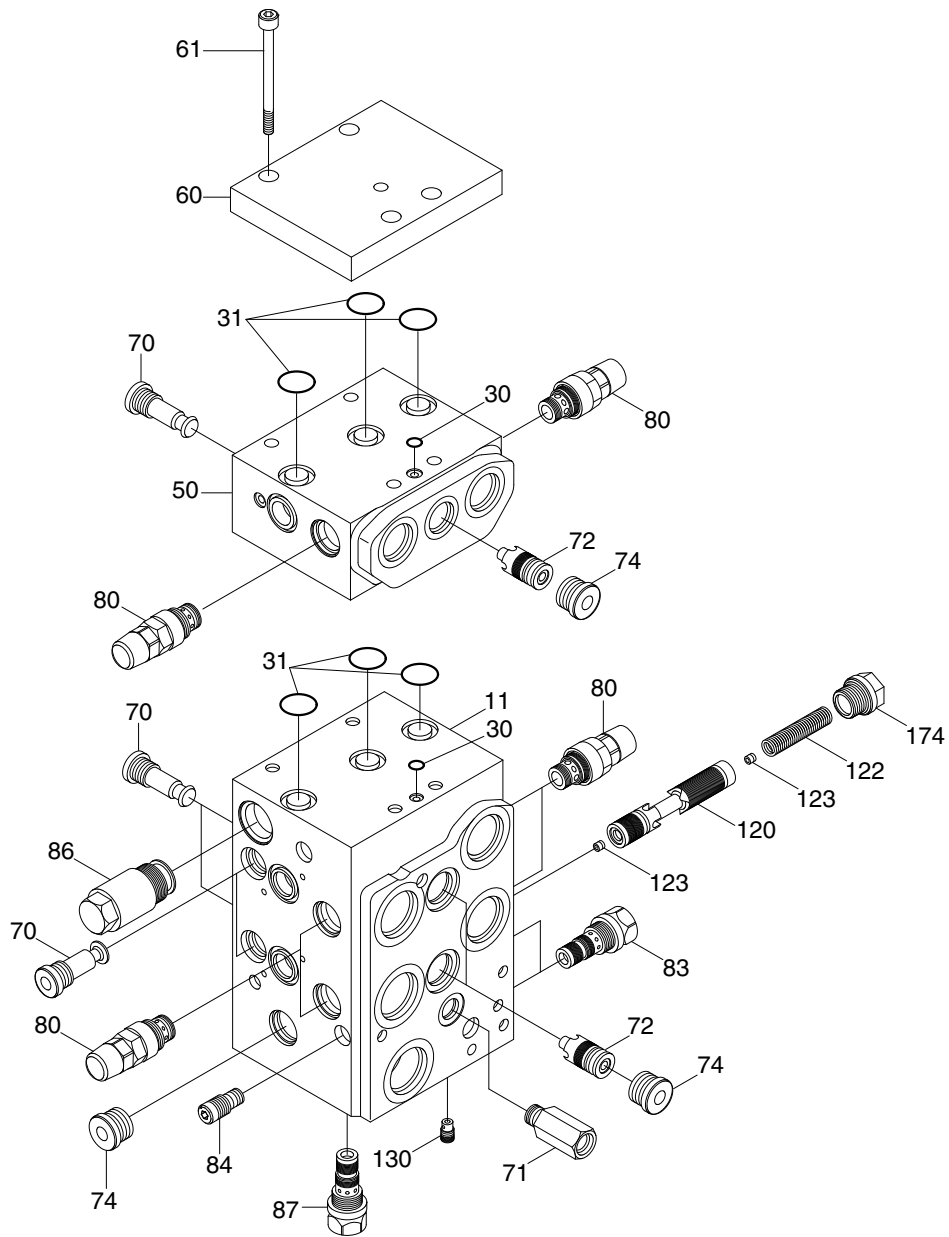

74096WE13

11	Housing	71	Shuttle valve	87	Pressure reducing valve
30	O-ring	72	Spool	120	Spool
31	O-ring	74	Locking screw	122	Pressure spring
50	Housing	80	Pressure relief valve	123	Orifice
60	Plate	83	Pressure relief valve	130	Check valve
61	Cylinder screw	84	Flow control valve	174	Locking screw
70	Check valve	86	Counter balance valve		

STRUCTURE (3/3)

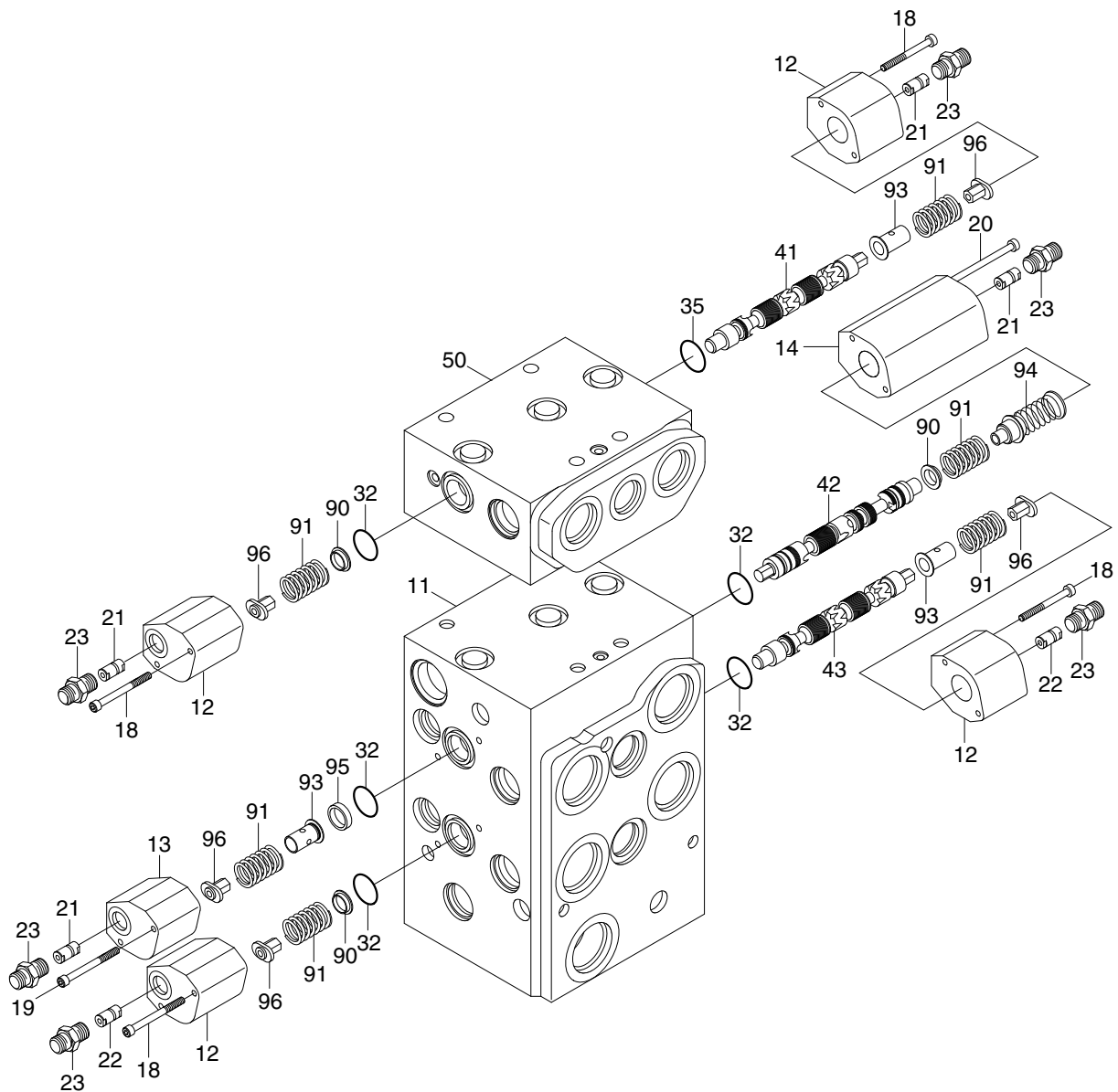

73096WE14

- | | | | | | |
|----|----------------------|----|-----------------------------|----|--------------------|
| 11 | Housing | 22 | Throttle check valve | 90 | Spring retainer |
| 12 | Cover | 23 | Threaded steel pipe fitting | 91 | Compression spring |
| 13 | Cover | 32 | O-ring | 93 | Spring retainer |
| 14 | Cover | 35 | O-ring | 94 | Spring |
| 18 | Cylinder screw | 41 | Spool | 95 | Ring |
| 19 | Cylinder screw | 42 | Spool | 96 | Spring retainer |
| 20 | Cylinder screw | 43 | Spool | | |
| 21 | Throttle check valve | 50 | Housing | | |

2) FUNCTION

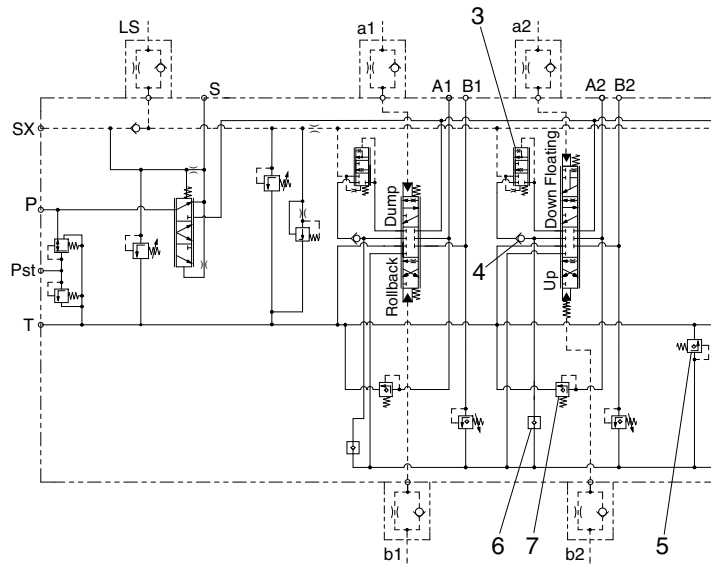
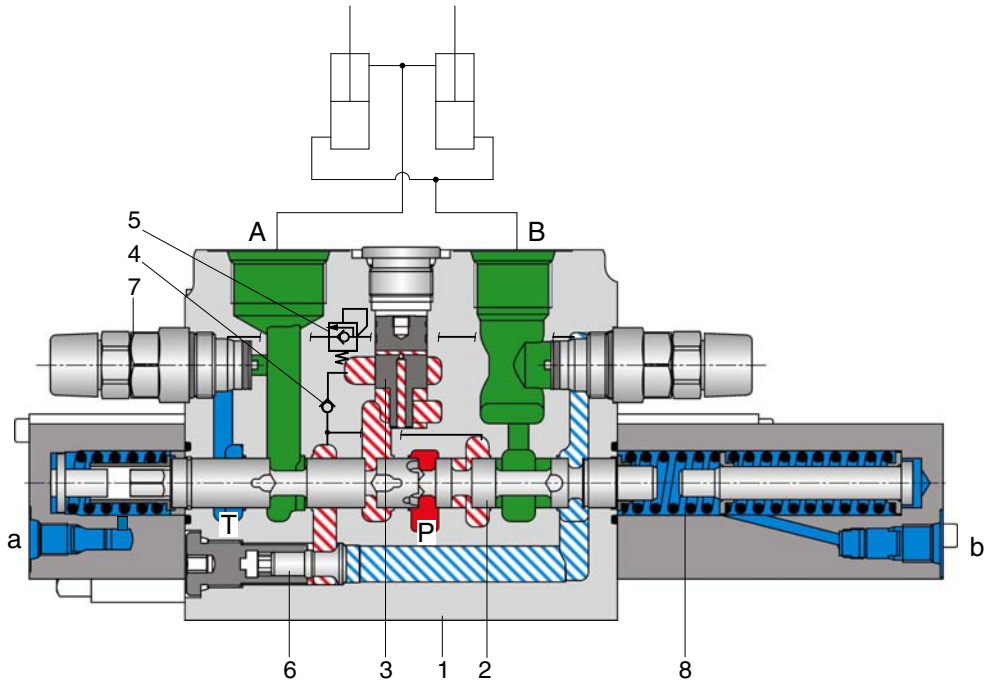

Hydraulic circuit

74096WE15

- | | | | | | |
|---|----------------------|---|--------------------------|---|-------------------|
| 1 | Housing | 4 | Loader holding valve | 7 | Port relief valve |
| 2 | Spool | 5 | Counter balance valve | 8 | Spring chamber |
| 3 | Pressure compensator | 6 | Regeneration check valve | | |

(1) Control block

Proportional direction valve to the LUDV principle (Load pressure - Independent - Flow - Distribution)

(2) Actuator control

At the spool (2) the direction and volume of flow is determined that flows to the actuator connections (A or B).

The spring chambers (8) are supplied with pilot pressure either via the pilot connections a and b hydraulic control.

The value of the pilot pressure within the spring chamber (8) determines the stroke of the spool (2).

The pressure compensator (3) controls the pressure differential at the spool (2) and therefore, the flow to the actuators (A, B).

(3) Loader pressure compensation (LUDV)

The control block works to the LUDV principle. In this load - sensing version the pressure compensators (3) are located between the spool (2) and the actuator connections (A, B).

The highest load pressure of all of the actuators involved is applied to all of the pressure compensators. In parallel it is also applied to the pump.

If the pump flow is insufficient for all of the functions, then all work movements are reduced in speed by the same ratio.

(4) Loading holding

Within each function axis a load holding valve (4) is fitted between the pressure compensator (3) and the actuator connections.

(5) Pressure safety, actuator connections

Large nominal size port relief valve (7) with combined anti-cavitation functions protect the actuators from overloads and cavitation.

(6) Float position

The float position is obtained by means of a 4-position spool.

(7) Regeneration

To prevent cavitation, with negative loads (e. g. dump or lowering), the tank port is pre-loaded via counter balance valve (5) and is fed with oil via the regeneration check valve (6) downstream of the pressure compensator.

3) BOOM SECTION OPERATION

(1) Spool in neutral

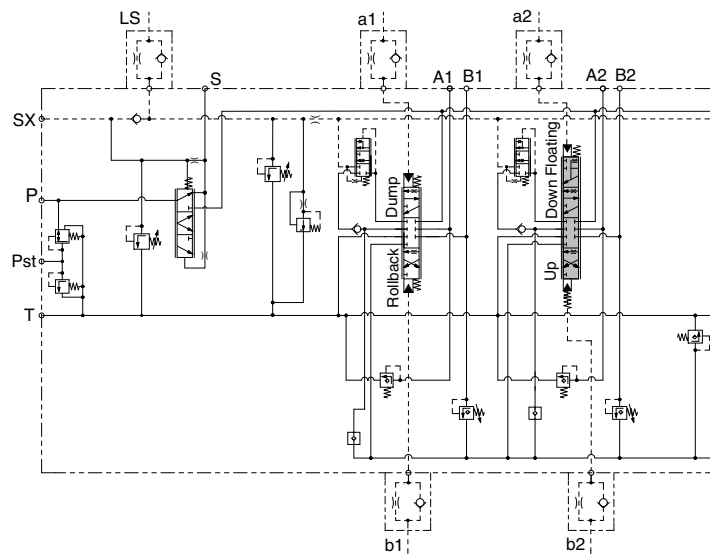
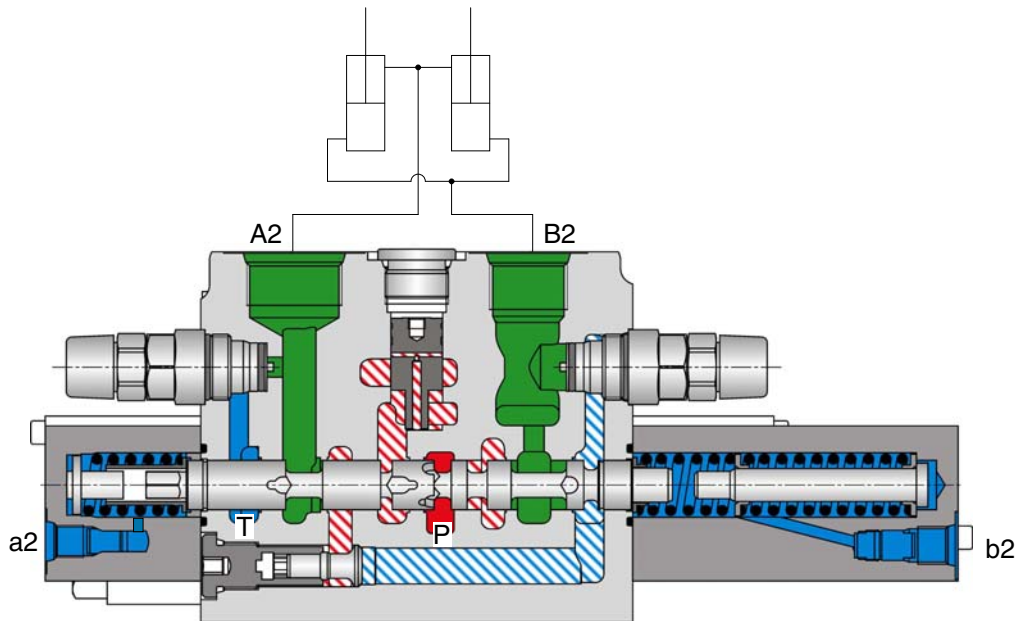

Hydraulic circuit

74096WE51

When the boom spool is in neutral position, oil from the pump will be blocked. Then, the pumps are at low pressure stand by.

(2) Boom raise position

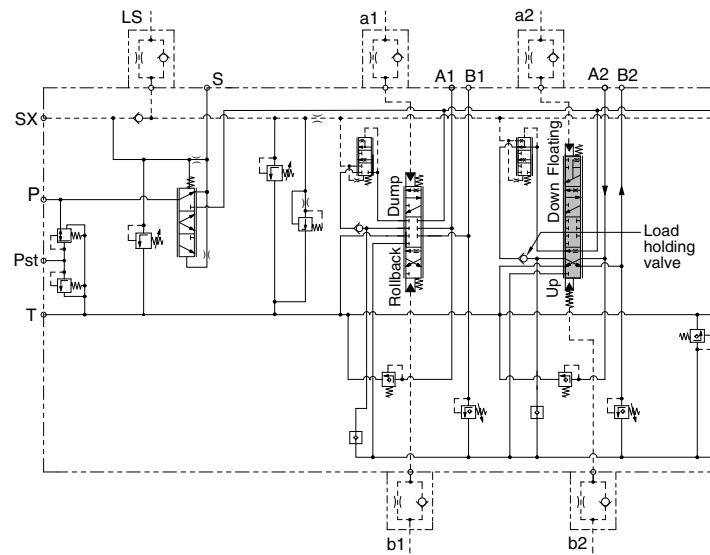
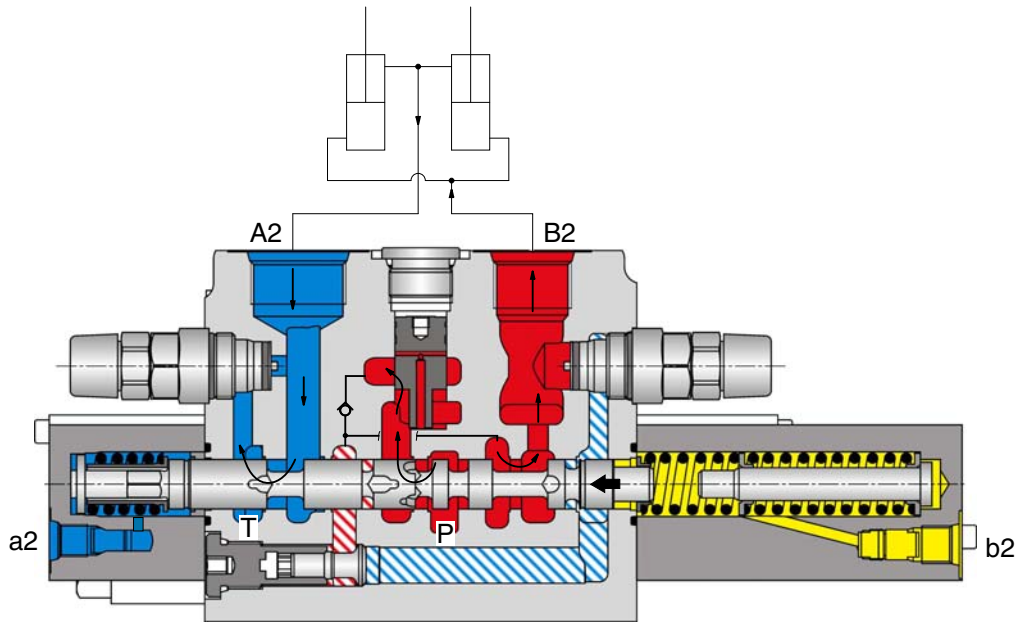

Hydraulic circuit

74096WE52

When the pilot pressure is led to the port b2, the boom spool moved to raise position. Oil from the pump flows to the cylinder port B2 through the load holding valve and oil from the cylinder flows into the tank passage through the cylinder port A2.

※ Load holding valve

When the load pressure is higher than the pump pressure, the load holding valve shuts off the passage between the high pressure feed passage and the center bypass passage and prevents the reverse flow from the cylinder.

(3) Boom lower position

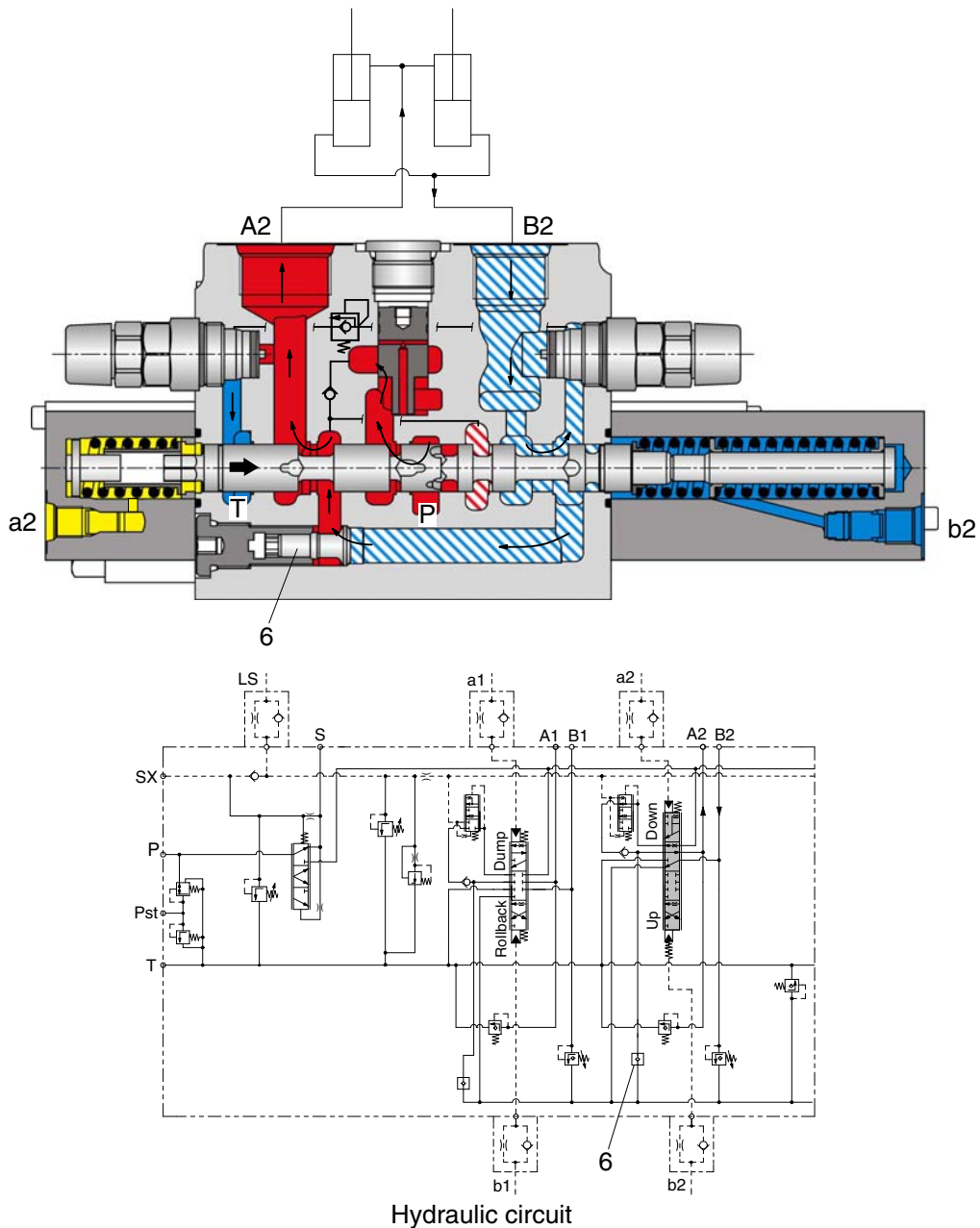

74096WE53

When the pilot pressure is led to the port a2, the boom spool moved to lower position. Oil from the pump flows to the cylinder port A2, through the load holding valve and oil from the cylinder flows into the tank passage through the cylinder port B2. When the lowering speed of boom is faster, the return oil from the large chamber of boom cylinder combines with the oil from the pump through regeneration check valve (6), and flows into the small chamber of the cylinder. This prevents cylinder cavitation by the negative pressure when the pump flow cannot match the boom down speed.

(4) Boom float position

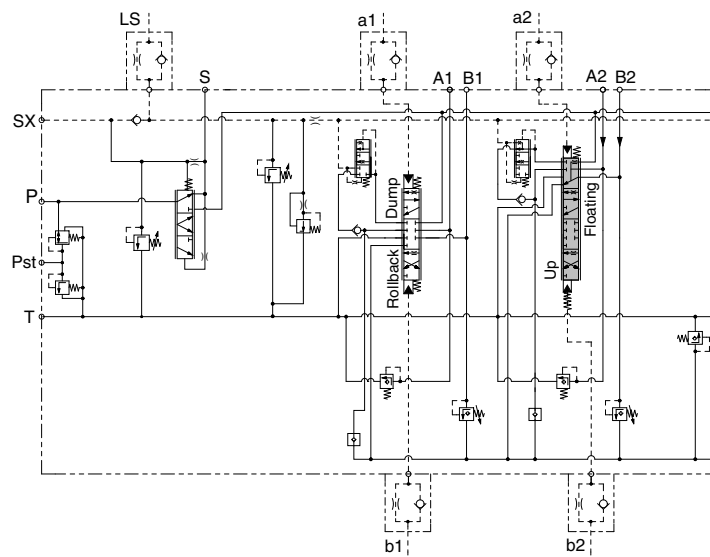
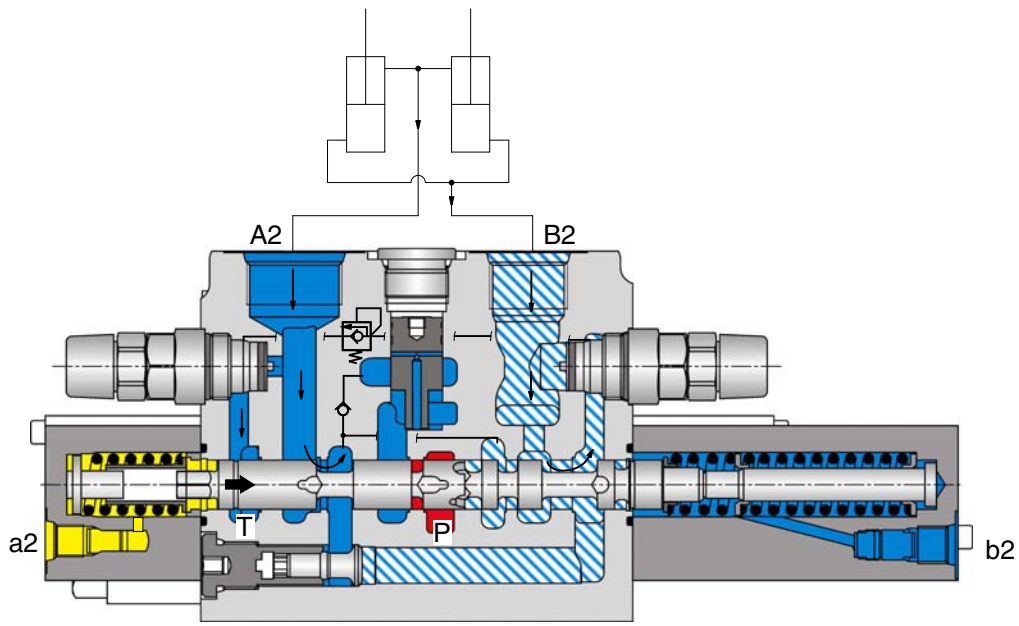

Hydraulic circuit

74096WE54

When the boom spool is located in float position, the oil from the pump will be blocked. The cylinder ports (A2, B2) are connected to the tank passage, so the boom will be lowered due to its own weight.

4) BUCKET SECTION OPERATION

(1) Spool in neutral

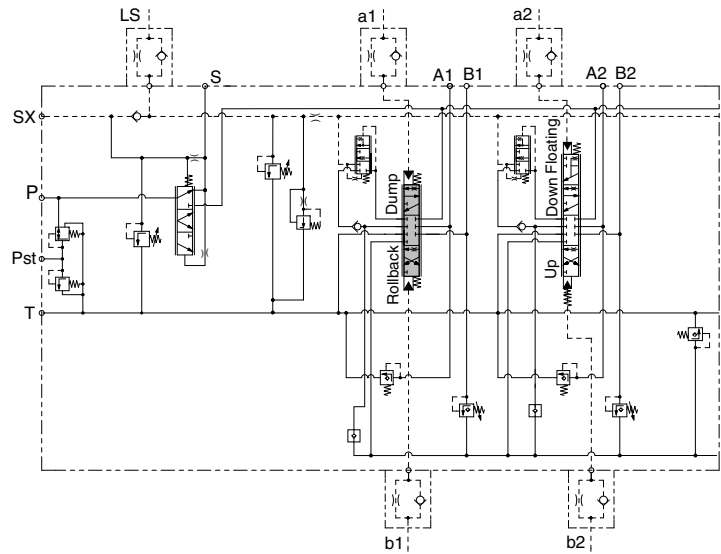
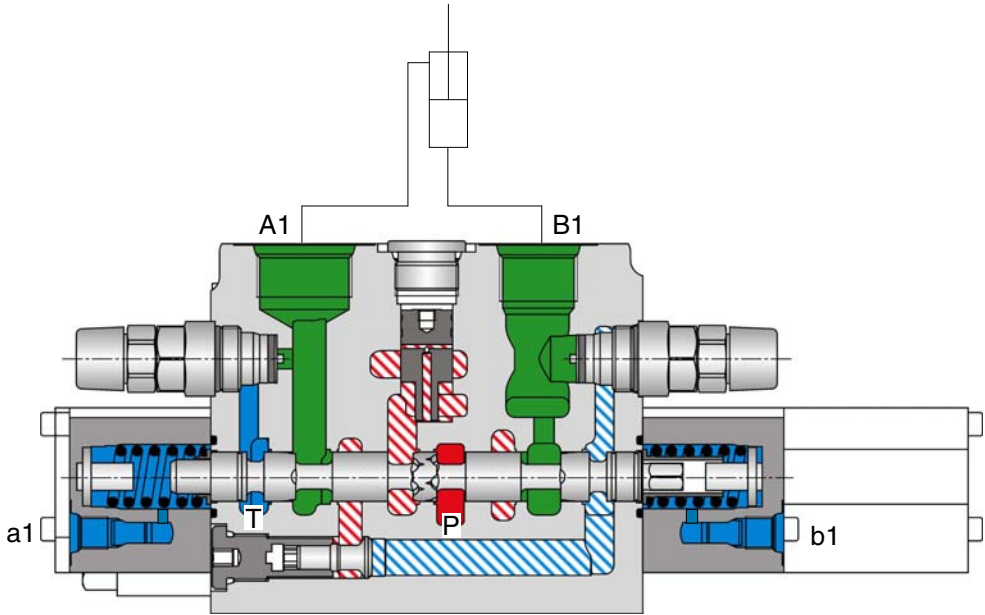

Hydraulic circuit

74096WE55

When the bucket spool is in neutral position, oil from the pump will be blocked. Then, the pumps are at low pressure standby.

(2) Bucket rollback position

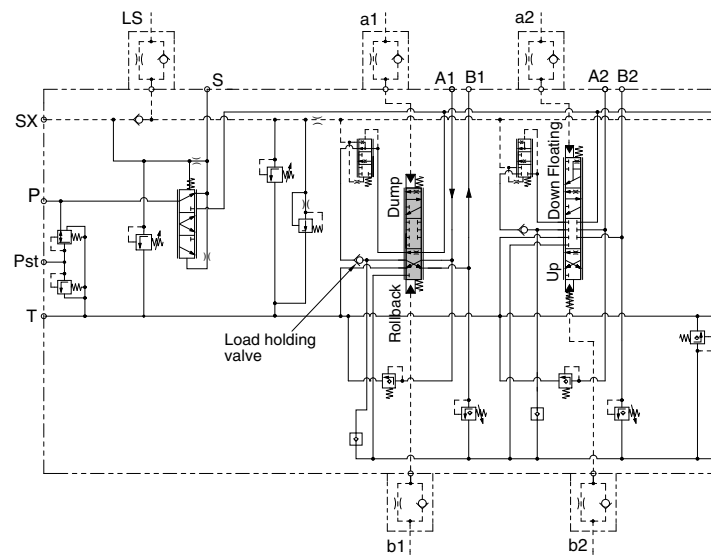
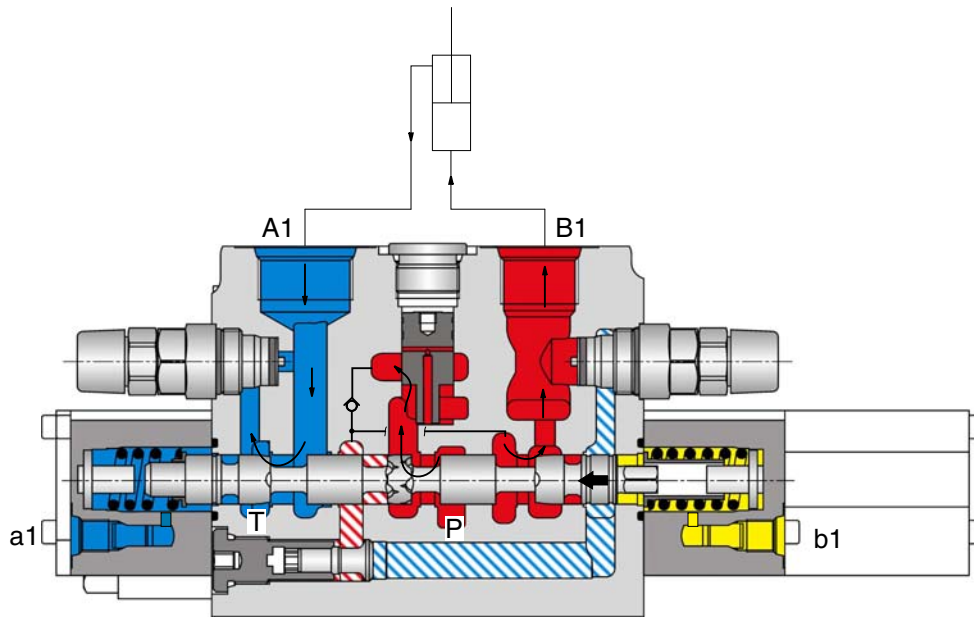

Hydraulic circuit

74096WE56

When the pilot pressure is led to the port b1, the bucket spool moved to rollback position. Oil from the pump flows to the cylinder port B1 through the load holding valve and oil from the cylinder flows into the tank passage through the cylinder port A1.

※ Load holding valve

When the load pressure is higher than the pump pressure, the load holding valve shuts off the passage between the high pressure feed passage and the center bypass passage and prevents the reverse flow from the cylinder.

(3) Bucket dump

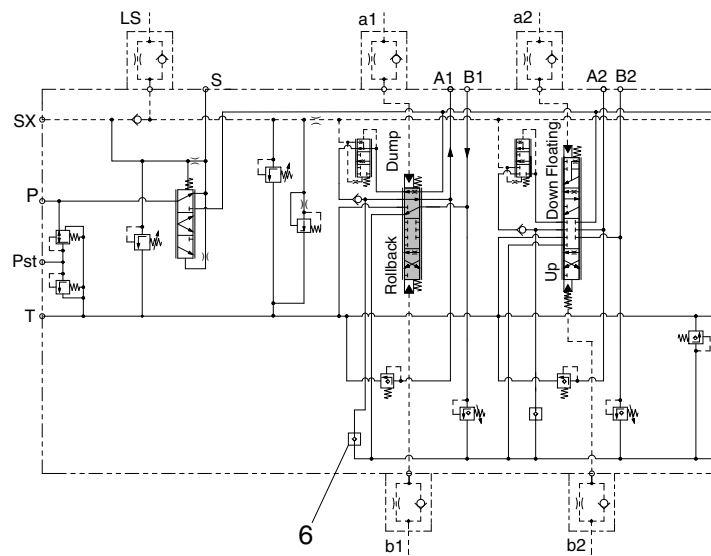
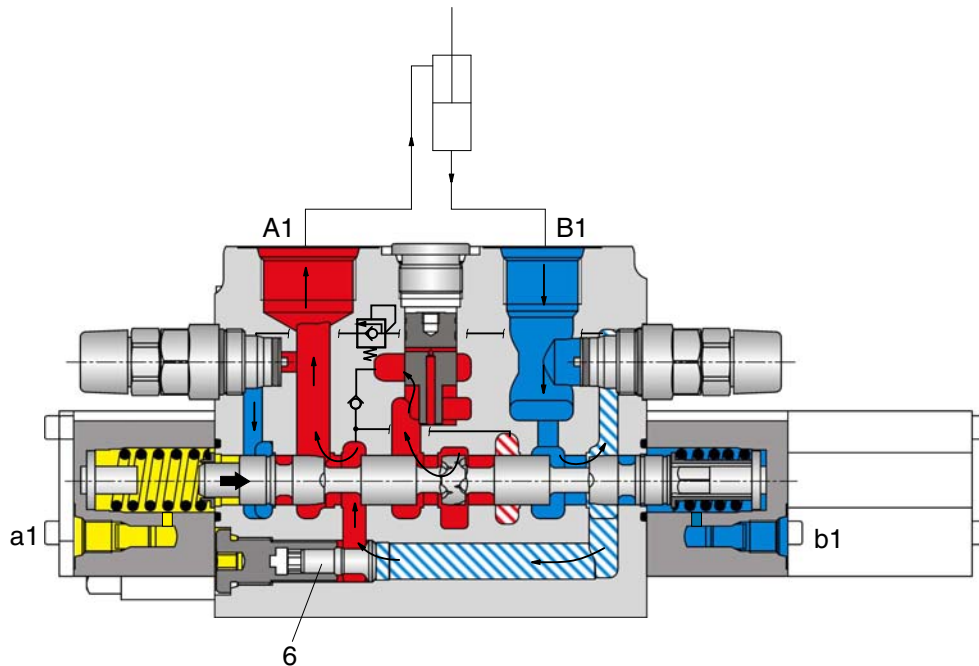

Hydraulic circuit

74096WE57

When the pilot pressure is led to the port a1, the bucket spool moved to dump position. Oil from the pump flows to the cylinder port A1, through the load holding valve and oil from the cylinder flows into the tank passage through the cylinder port B1. When the dumping speed of bucket is faster, the return oil from the large chamber of bucket cylinder combines with the oil from the pump through regeneration check valve (6), and flows into the small chamber of the cylinder. This prevents cylinder cavitation by the negative pressure when the pump flow cannot match the bucket dump speed.

7. SAFETY VALVE

1) STRUCTURE

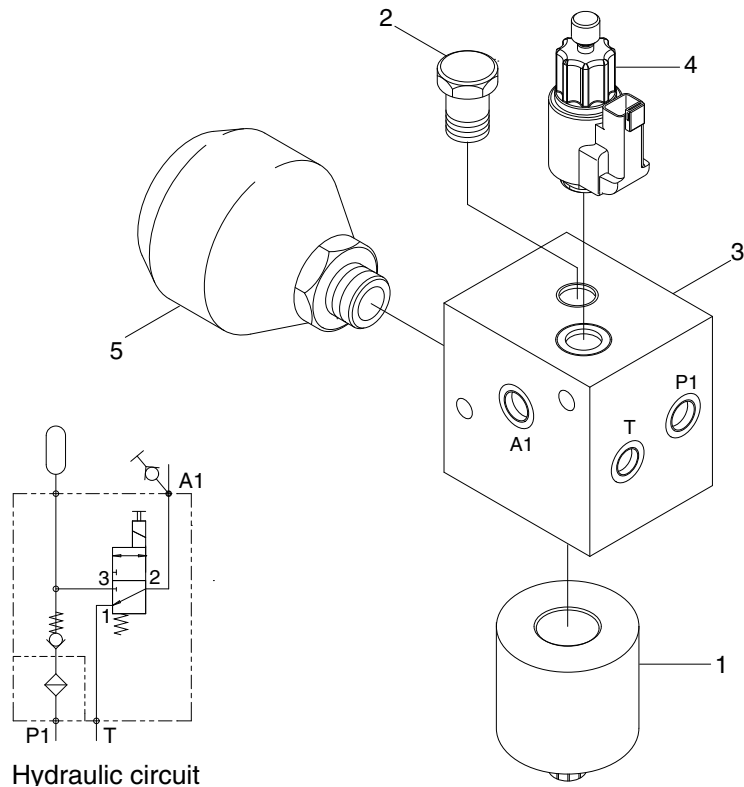

Port	Port name	Port size
P1	From MCU	PF 3/8"
A1	Supply to RCV lever	PF 1/4"
T	To hydraulic tank	PF 1/4"

75796WE16

- | | | | |
|---|-----------------------|---|----------------|
| 1 | Bowl and element assy | 4 | Solenoid valve |
| 2 | Check valve | 5 | Accumulator |
| 3 | Cartridge | | |

2) OPERATION

This valve is used to cut off the pilot circuit.

When the pilot cut off switch in the cab is pressed to ON position, the solenoid valve is activated and then the pilot oil flow into the pilot circuit.

The accumulator satisfied short term peak power demands and is a source of emergency power in case of main circuit pressure failures.

8. BOOM AND BUCKET CYLINDER

The boom cylinders are two unit and the bucket cylinder is one unit. They use a bolt on rod guide.

The piston (14) threads on to the rod (2) and is retained by a nut (20) and set screw (21).

The piston seals against the tube (1) with piston seal (15). Two wear rings (16) are located on each side of the piston seal.

The gland (3, the rod guide) seals against the tube with an O-ring (12). The cylinder thread seals against the rod with a lip type buffer ring (8) and a rod seal (5). A dust wiper (9) cleans the rod when it is retracted.

1) BOOM CYLINDER

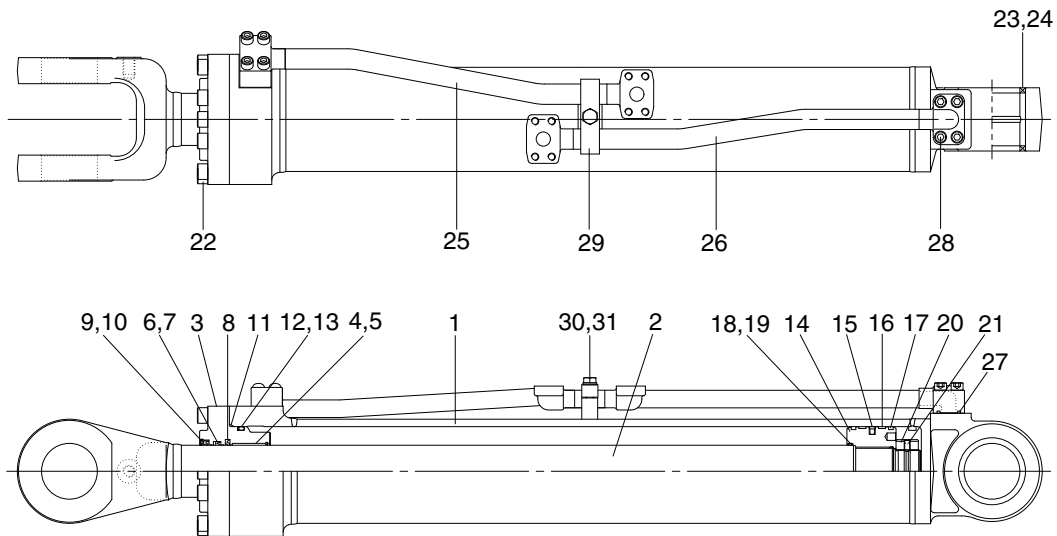

73096WE17

1	Tube assembly	12	O-ring	23	Bushing
2	Rod assembly	13	Back up ring	24	Dust seal
3	Gland	14	Piston	25	Pipe assembly
4	Bushing	15	Piston seal	26	Pipe assembly
5	Snap ring	16	Wear ring	27	O-ring
6	Rod seal	17	Dust ring	28	Bolt
7	Back up ring	18	O-ring	29	Clamp
8	Buffer ring	19	Back up ring	30	Bolt
9	Dust wiper	20	Lock nut	31	Spring washer
10	Snap ring	21	Set screw		
11	O-ring	22	Bolt		

2) BUCKET CYLINDER (HL730-9)

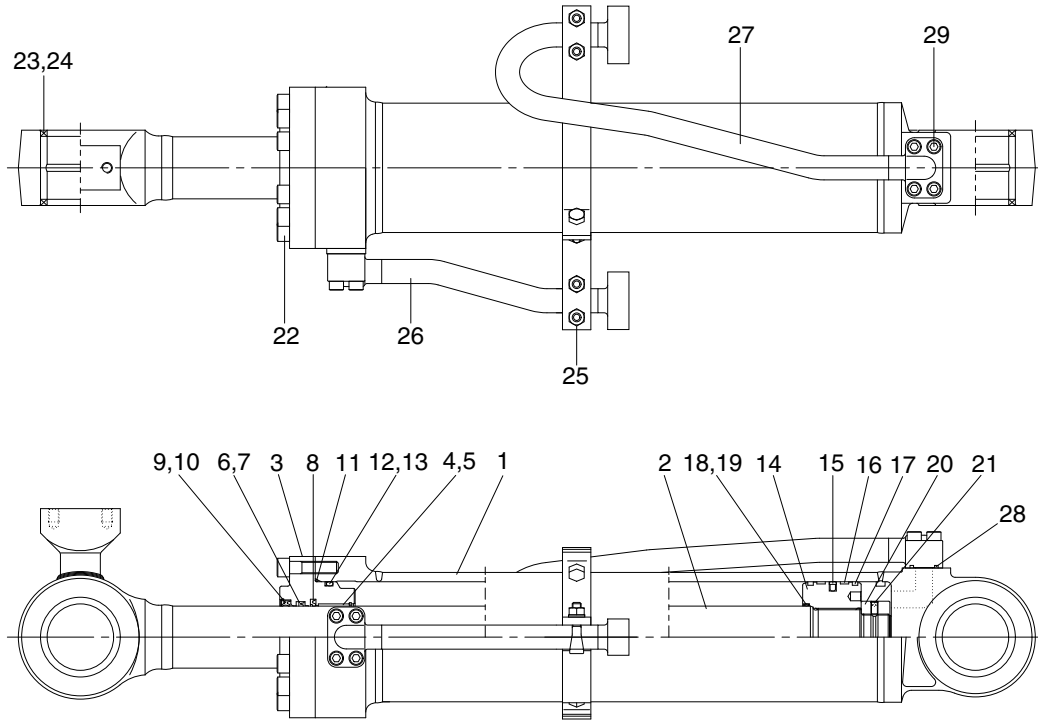

73096WE22

1	Tube assembly	11	O-ring	21	Set screw
2	Rod assembly	12	O-ring	22	Bolt
3	Gland	13	Back up ring	23	Bushing
4	Bushing	14	Piston	24	Dust seal
5	Snap ring	15	Piston seal	25	Band assembly
6	Rod seal	16	Wear ring	26	Pipe assembly
7	Back up ring	17	Dust ring	27	Pipe assembly
8	Buffer ring	18	O-ring	28	O-ring
9	Dust wiper	19	Back up ring	29	Bolt
10	Snap ring	20	Lock nut		

3) BUCKET CYLINDER (HL730TM-9)

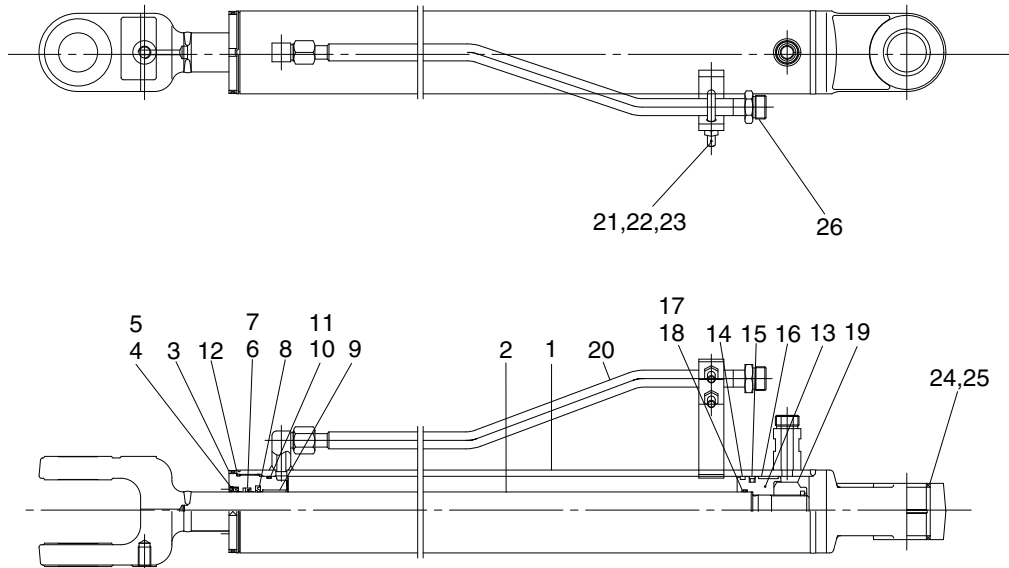

73096WE22A

- | | | | | | |
|----|---------------|----|---------------|----|---------------|
| 1 | Tube assembly | 11 | Back up ring | 21 | U-bolt |
| 2 | Rod assembly | 12 | O-ring | 22 | Nut |
| 3 | Gland | 13 | Piston | 23 | Spring washer |
| 4 | Dust wiper | 14 | Dust seal | 24 | Pin bush |
| 5 | Retain ring | 15 | Piston seal | 25 | Dust seal |
| 6 | Rod seal | 16 | Wear ring | 26 | O-ring |
| 7 | Back up ring | 17 | O-ring | | |
| 8 | Buffer ring | 18 | Back up ring | | |
| 9 | Dry bearing | 19 | Nylon nut | | |
| 10 | O-ring | 20 | Pipe assembly | | |

9. HYDRAULIC OIL TANK

1) STRUCTURE

- The oil from the hydraulic tank is sent from the pump through main control valve to the cylinders. In the return circuit, the oil from various parts merges.
- A part of oil is cooled in the oil cooler, passes through the hydraulic filter and returns to the hydraulic tank (1).
- If the hydraulic return oil filter becomes clogged, return filter bypass valve (6) acts to allow the oil to return directly to the hydraulic tank (1). This prevents damage to the hydraulic filter (7). The bypass valve (6) is also actuated when negative pressure is generated in the circuit.

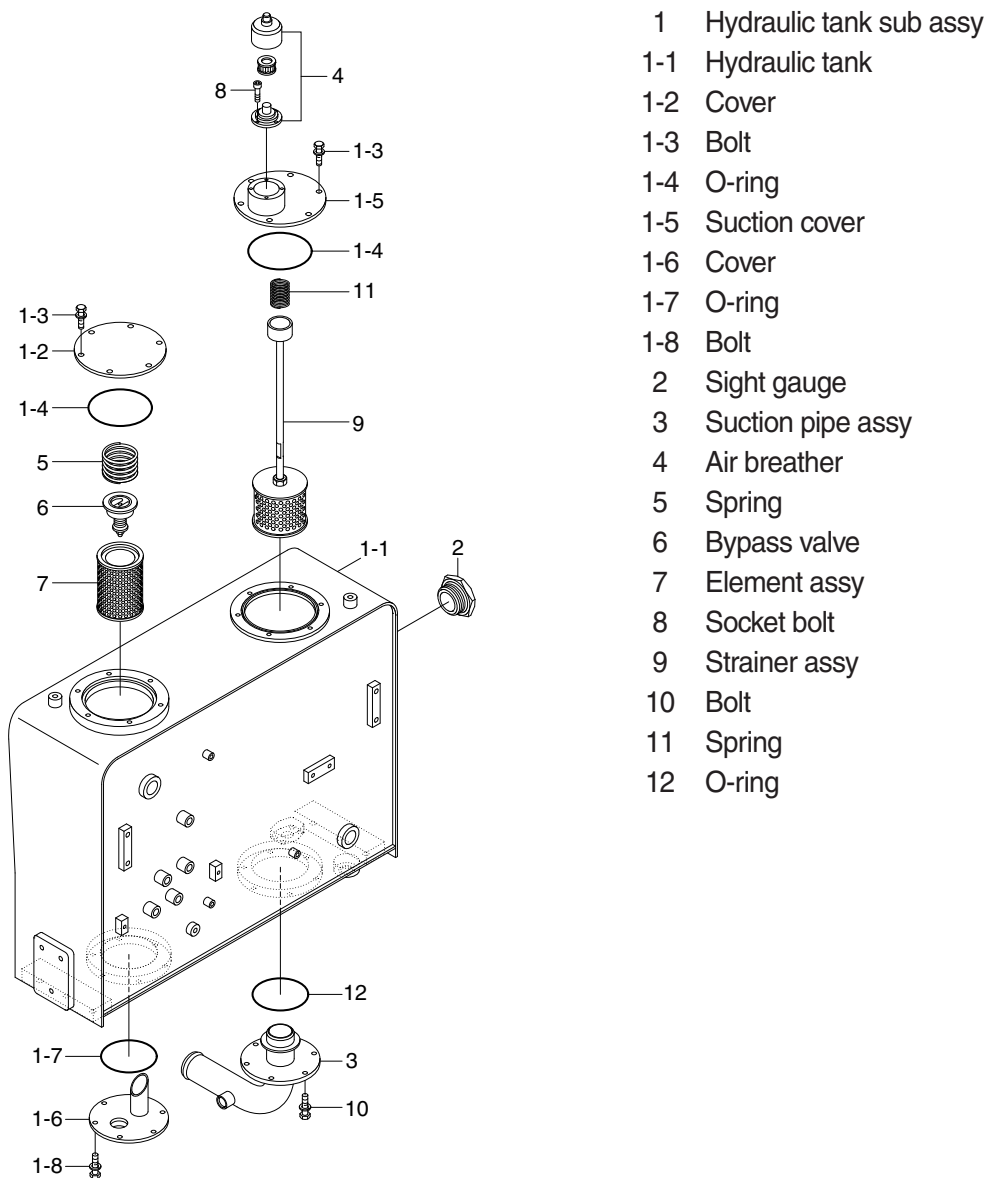

- 1 Hydraulic tank sub assy
- 1-1 Hydraulic tank
- 1-2 Cover
- 1-3 Bolt
- 1-4 O-ring
- 1-5 Suction cover
- 1-6 Cover
- 1-7 O-ring
- 1-8 Bolt
- 2 Sight gauge
- 3 Suction pipe assy
- 4 Air breather
- 5 Spring
- 6 Bypass valve
- 7 Element assy
- 8 Socket bolt
- 9 Strainer assy
- 10 Bolt
- 11 Spring
- 12 O-ring

2) RETURN OIL FILTER BYPASS VALVE

(1) When the filter is clogged

Bypass valve (1) is opened and the oil returns directly to the tank without passing through the filter.

- Bypass valve set pressure : 1.36 kg/cm²
(19.3 psi)

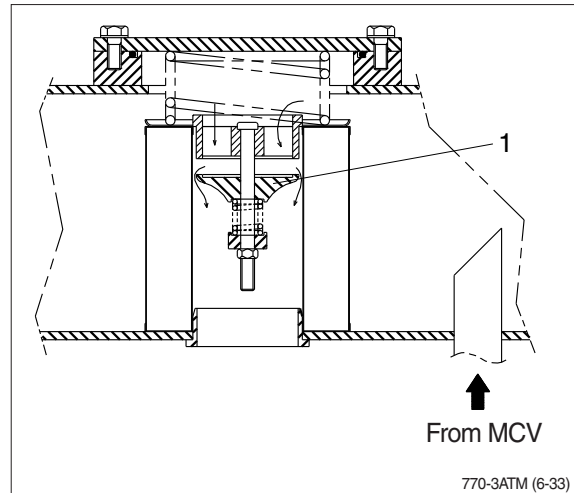

3) AIR BREATHER

The air breather is equipped with the capacity to perform three functions simultaneously-as an air filter, breathing valve, and as a lubrication opening.

(1) Preventing negative pressure inside the tank

The tank is a pressurized sealed type, so negative pressure is formed inside the hydraulic tank when the oil level drops during operations. When this happens, the difference in pressure between the tank and the outside atmospheric pressure opens the poppet in the breather, and air from the outside is let into the tank or prevent negative pressure.

(2) Preventing excessive pressure inside the tank

When the hydraulic cylinder is being used, the oil level in the hydraulic system increases and as temperature rises. If the hydraulic pressure rises above the set pressure, breather is actuated to release the hydraulic pressure inside the tank.

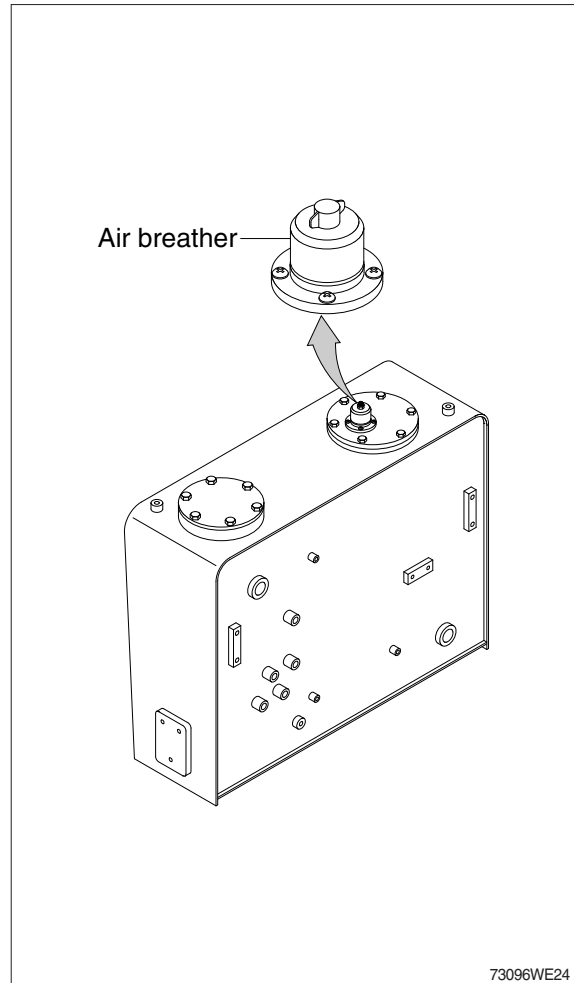

73096WE24

10. ACCUMULATOR

The accumulator is installed at the safety valve. When the boom is left the raised position, and the control levers are operated with the engine stopped the pressure of the compressed nitrogen gas inside the accumulator sends pilot pressure to the control valve to actuate it and allow the boom and bucket to come down under their own weight.

Type of gas	Nitrogen gas (N ₂)
Volume of gas	0.75 l (0.2 U.S.gal)
Charging pressure of gas	16 kg/cm ² (228 psi)
Max actuating pressure	128 kg/m ² (1820 psi)

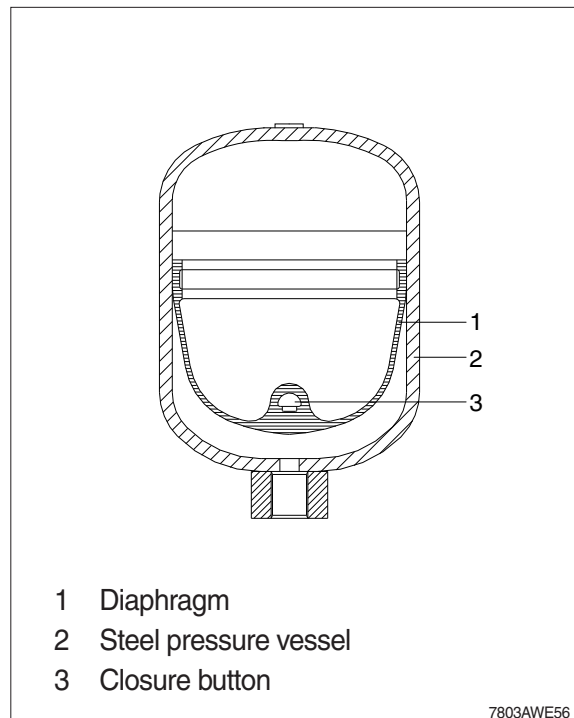

- 1 Diaphragm
- 2 Steel pressure vessel
- 3 Closure button

7803AWE56

11. RIDE CONTROL SYSTEM (option)

1) ACCUMULATORS

(1) Pre-charging

Use an inert gas such as nitrogen for pre-charging accumulator.

- ※ Do not use oxygen or shop air.
- ※ Nitrogen source and all components must be rated for a pressure at least as high as the nitrogen source.

Accumulator having gas valve as per figure 1.

- ① Remove gas valve guard and gas valve cap.
- ② Back gas chuck "T" handle (A) all the way out (counter clockwise) before attaching charging & gauging kit to accumulator gas valve.
- ③ Close bleed valve (B).
- ④ Making sure not to loop or twist the hose, attach swivel nut (C) to gas valve and tighten 11.5~17 kgf·cm (10~15 lbf·ft).
- ⑤ Turn gas chuck "T" handle (A) until the gauge starts showing the pressure in the accumulator. Do not turn the "T" handle all the way down, as it will damage the valve core.
- ⑥ Crack open nitrogen bottle valve (D) and **slowly** fill accumulator. Shut off when gauge indicates desired pre-charge.
- ⑦ Let the pre-charge set for 10 to 15 minutes. This will allow the gas temperature to stabilize. If the desired pre-charge is exceeded, close nitrogen bottle valve (D), then slowly open bleed valve (B). Do not reduce pre-charge by depressing valve core with a foreign object. High pressure may rupture rubber valve seat.
- ⑧ When finished pre-charging accumulator, turn "T" handle (A) all the way out on gas chuck, then open bleed valve (B).
- ⑨ Hold gas valve to keep from turning, loosen swivel nut (C), remove assembly. Check for pre-charge leak using a common leak reactant.
- ⑩ Replace gas valve cap 11.5~17 kgf·cm (10~15 lbf·ft) and valve guard. (Gas valve cap serves as a secondary seal.)

(2) Pre-charge checking procedure

Using appropriate valve in the hydraulic system, discharge all oil from accumulator and allow piston to bottom against hydraulic end cap.

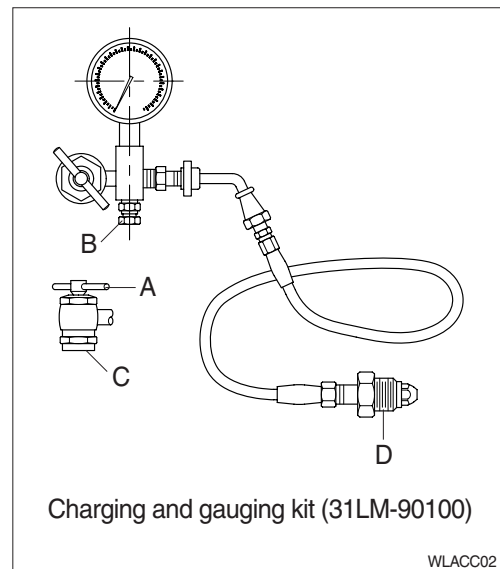
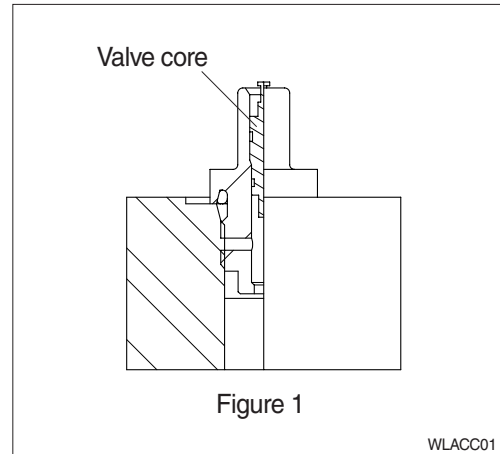

(3) Structure

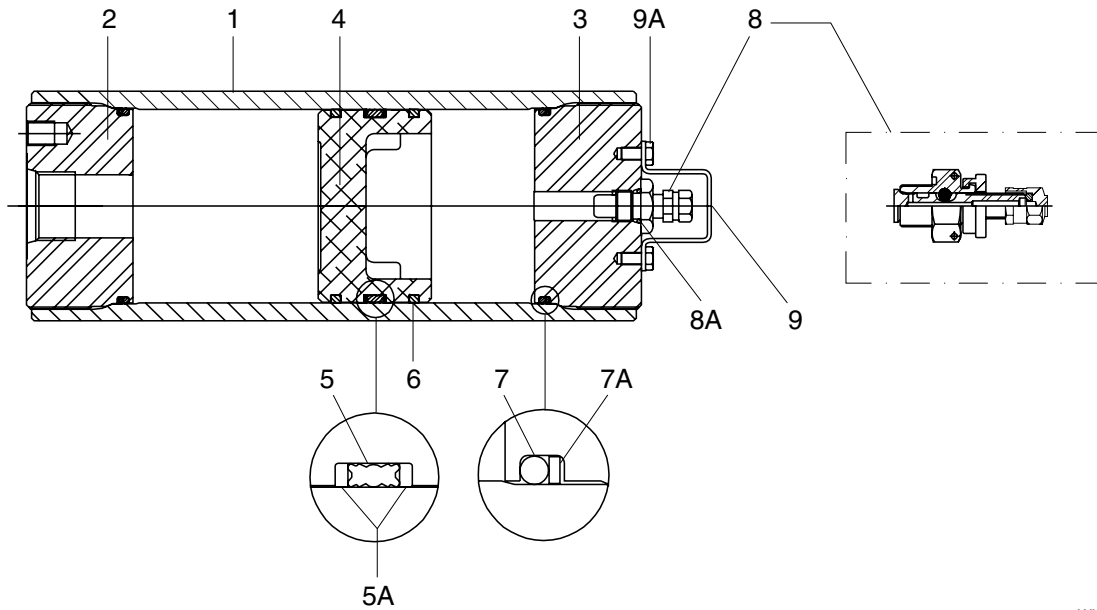

WLACC03

- 1 Body
- 2 Hydraulic cap
- 3 Gas cap
- 4 Piston
- 5 V-O-ring
- 5A V-O-ring back-up washers
- 6 Piston ring (piston)
- 7 O-ring
- 7A O-ring back-up washer
- 8 Gas valve
- 8A Gas valve O-ring
- 9 Gas valve guard
- 9A Screw

Specification for accumulator

Item	31LM-90030
Length	527.1 mm
Norminal volume	3.0 l
Precharge pressure	25 ± 1.3 bar
Operating medium	Oil
Weight	25.3 kg
Priming gas	Nitrogen

▲ Before carrying out any maintenance work the accumulators must be unloaded (zero pressure). Refer to the page 6-54.