

SECTION 6 WORK EQUIPMENT

GROUP 1 STRUCTURE AND FUNCTION

1. HYDRAULIC SYSTEM OUTLINE

The loader hydraulic system is a pilot operated, open center system which is supplied with flow from the fixed displacement main hydraulic pump.

The pilot control system is a low pressure, closed center hydraulic system which is supplied with flow from the first(Steering) pump.

The loader system components are :

- Main pump
- Remote control valve(Pilot control valve)
- Main control valve
- Safety valve
- Pilot supply unit
- Boom cylinders
- Bucket cylinder

The pilot supply unit consists of the pressure reducing valve, relief valve and accumulator.

Flow from the main hydraulic pump not used by the steering system leaves the priority valve EF port. It flows to the inlet port plate of four blocks type main control valve.

The main control valve is a tandem version spool type, open center valve which routes flow to the boom, bucket or auxiliary cylinders(Not shown) when the respective spools are shifted.

Flow from the steering pump(The first pump) is routed to the pilot supply unit where the steering pump outlet pressure is reduced to pilot circuit pressure. The pilot supply unit flow to the remote control valve.

The remote control valve routed flow to either end of each spool valve section in the main control valve to control spool stroke.

A accumulator mounted on pilot supply unit supplies a secondary pressure source to operated remote control valve so the boom can be lowered if the engine is off.

The return circuit for the main hydraulic system have return filter inside the hydraulic tank. The return filter uses a filter element and a bypass valve. The bypass valve is located in the upside of filter.

2. HYDRAULIC CIRCUIT

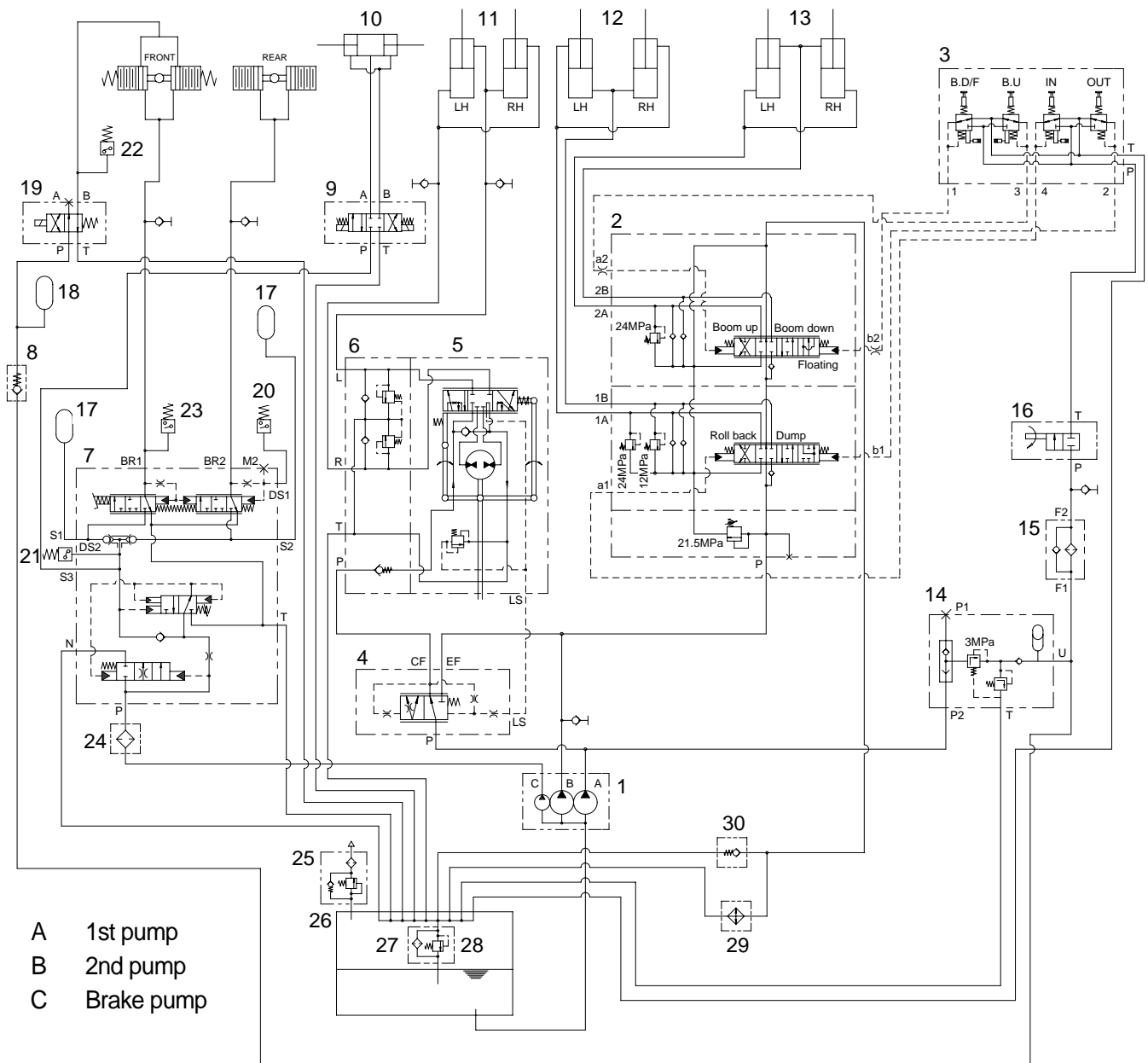

A 1st pump
 B 2nd pump
 C Brake pump

- | | | | | | |
|----|----------------------|----|-------------------|----|-----------------------|
| 1 | Main pump | 11 | Steering cylinder | 21 | Pressure switch |
| 2 | Main control valve | 12 | Bucket cylinder | 22 | Pressure switch |
| 3 | Remote control valve | 13 | Boom cylinder | 23 | Pressure switch |
| 4 | Priority valve | 14 | Pilot supply unit | 24 | Line filter |
| 5 | Steering unit | 15 | Line filter | 25 | Air breather |
| 6 | Valve block | 16 | Safety valve | 26 | Hydraulic tank |
| 7 | Brake valve | 17 | Accumulator | 27 | Return filter |
| 8 | Check valve | 18 | Accumulator | 28 | Bypass valve |
| 9 | Solenoid valve | 19 | Solenoid valve | 29 | Oil cooler(Optional) |
| 10 | Coupler cylinder | 20 | Pressure switch | 30 | Check valve(Optional) |

3. WORK EQUIPMENT HYDRAULIC CIRCUIT

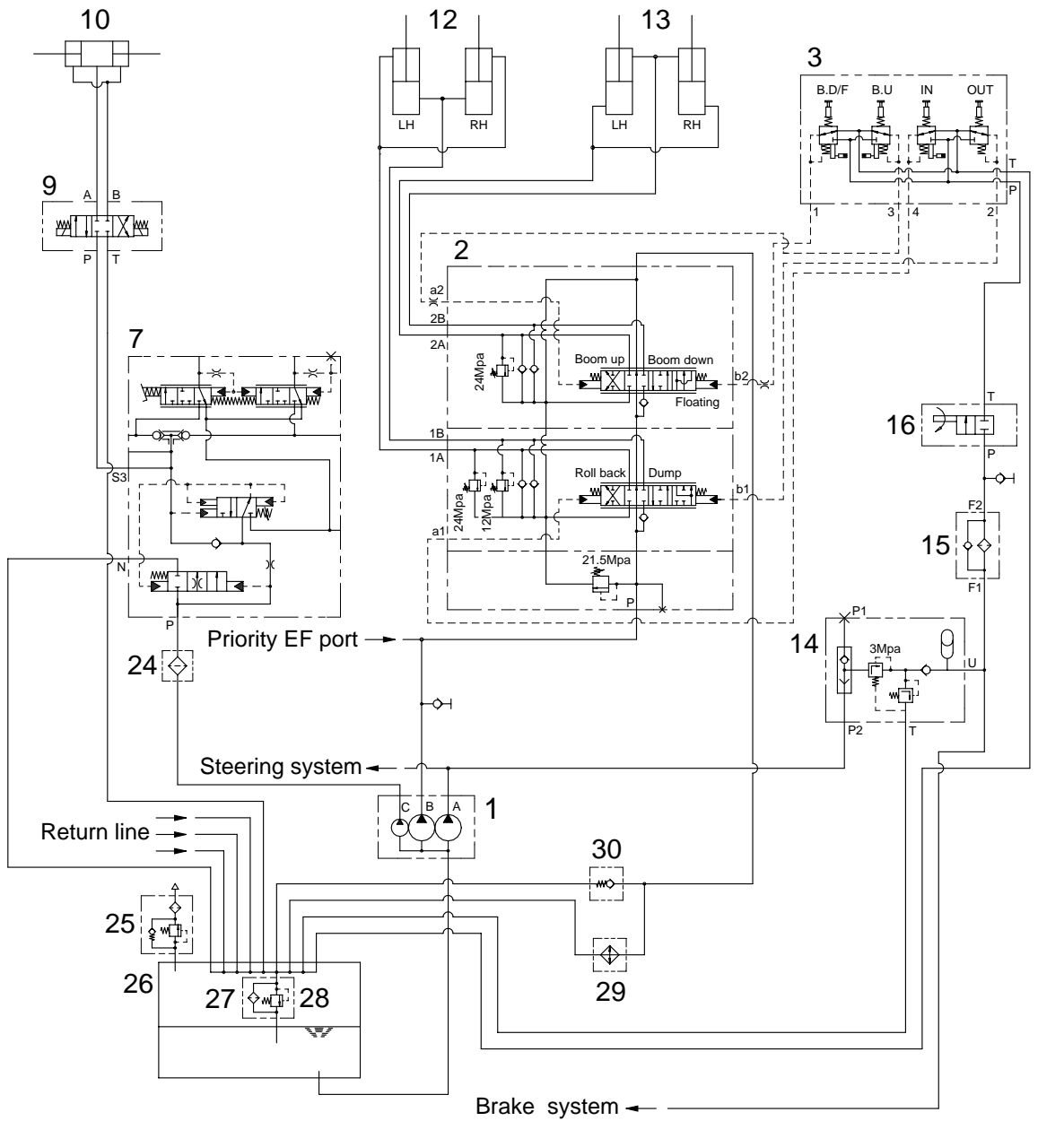

A 1st pump
 B 2nd pump
 C Brake pump

- | | | |
|------------------------|----------------------|--------------------------|
| 1 Main pump | 12 Bucket cylinder | 25 Air breather |
| 2 Main control valve | 13 Boom cylinder | 26 Hydraulic tank |
| 3 Remote control valve | 14 Pilot supply unit | 27 Return filter |
| 7 Brake valve | 15 Line filter | 28 Bypass valve |
| 9 Solenoid valve | 16 Safety valve | 29 Oil cooler(Optional) |
| 10 Coupler cylinder | 24 Line filter | 30 Check valve(Optional) |

1) WHEN THE RCV LEVER IS IN THE RAISE POSITION

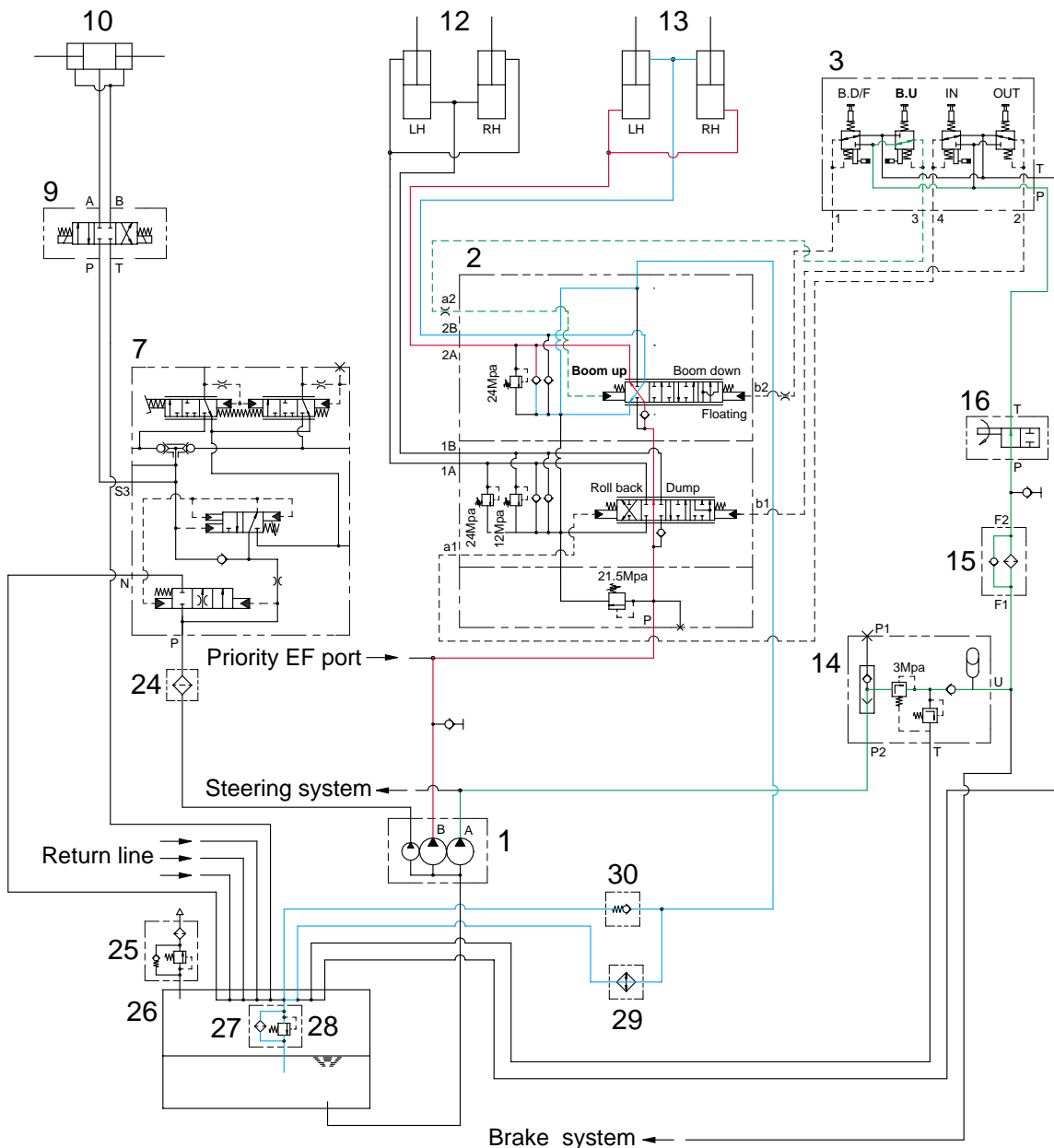

A 1st pump
B 2nd pump

- When the RCV lever(3) is pulled back, the boom spool on the second block is moved to raise position by pilot oil pressure from port 3 of RCV.
- The oil from main pump(1) flows into main control valve(2) and then goes to the large chamber of boom cylinder(13) by pushing the load check valve of the boom spool through center bypass circuit of the bucket spool.
- The oil from the small chamber of boom cylinder(13) returns to hydraulic oil tank(26) through the boom spool at the same time.
- When this happens, the boom goes up.

2) WHEN THE RCV LEVER IS IN THE LOWER POSITION

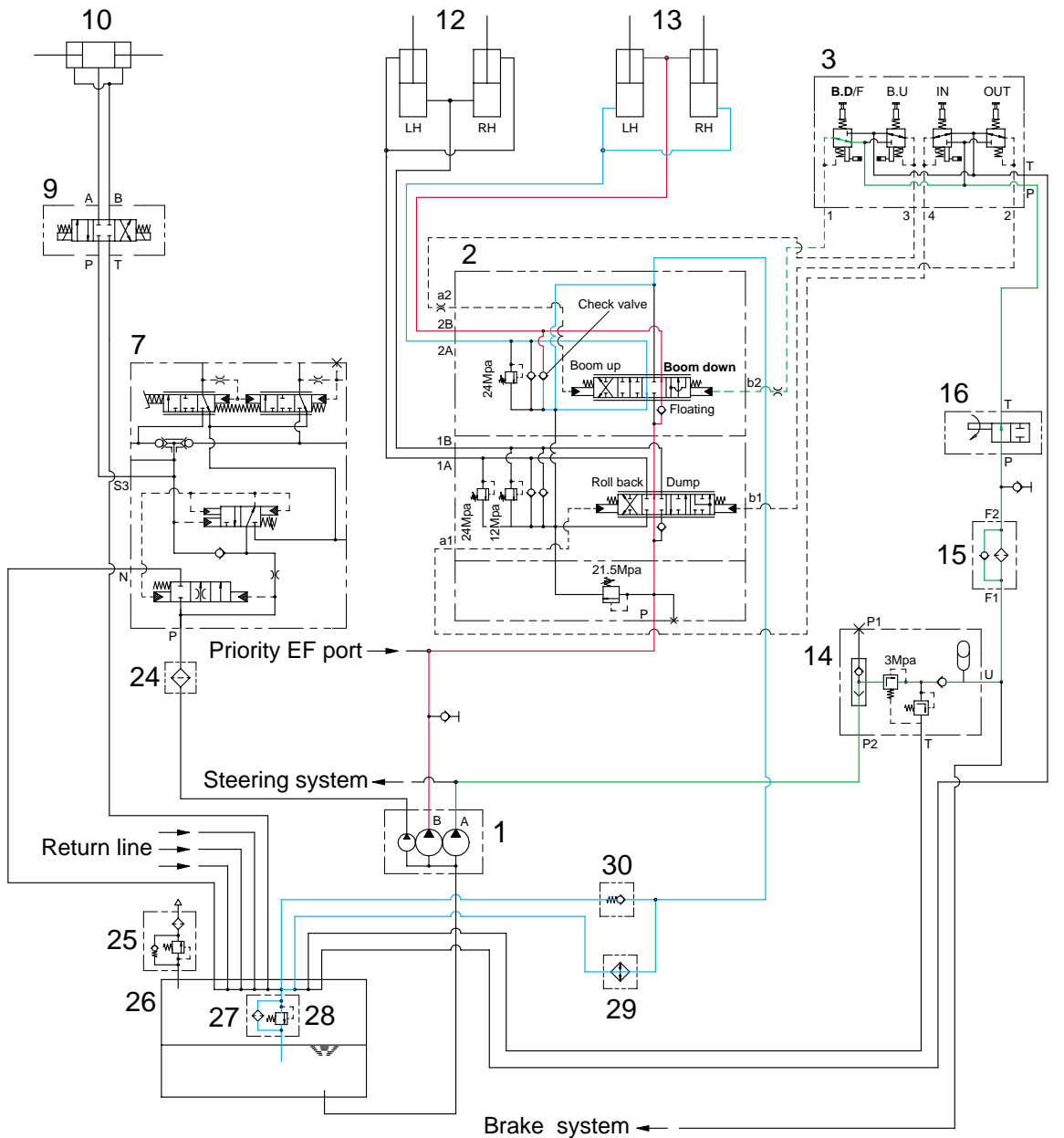

A 1st pump
B 2nd pump

- When the RCV lever(3) is pushed forward, the boom spool on the second block is moved to lower position by pilot pressure from port 1 of RCV.
- The oil from main pump(1) flows into main control valve and then goes to small chamber of boom cylinder(13) by pushing the load check valve of the boom spool through center bypass circuit of the bucket spool.
- The oil returned from large chamber of boom cylinder(13) returns to hydraulic tank(26) through the boom spool at the same time.
- When the lowering speed of boom is faster, the return oil from the large chamber of boom cylinder combines with the oil from the pump through the check valve, and flows into the small chamber of the cylinder.

This prevents cylinder cavitation by the negative pressure when the pump flow cannot match the boom down speed.

3) WHEN THE RCV LEVER IS IN THE FLOAT POSITION

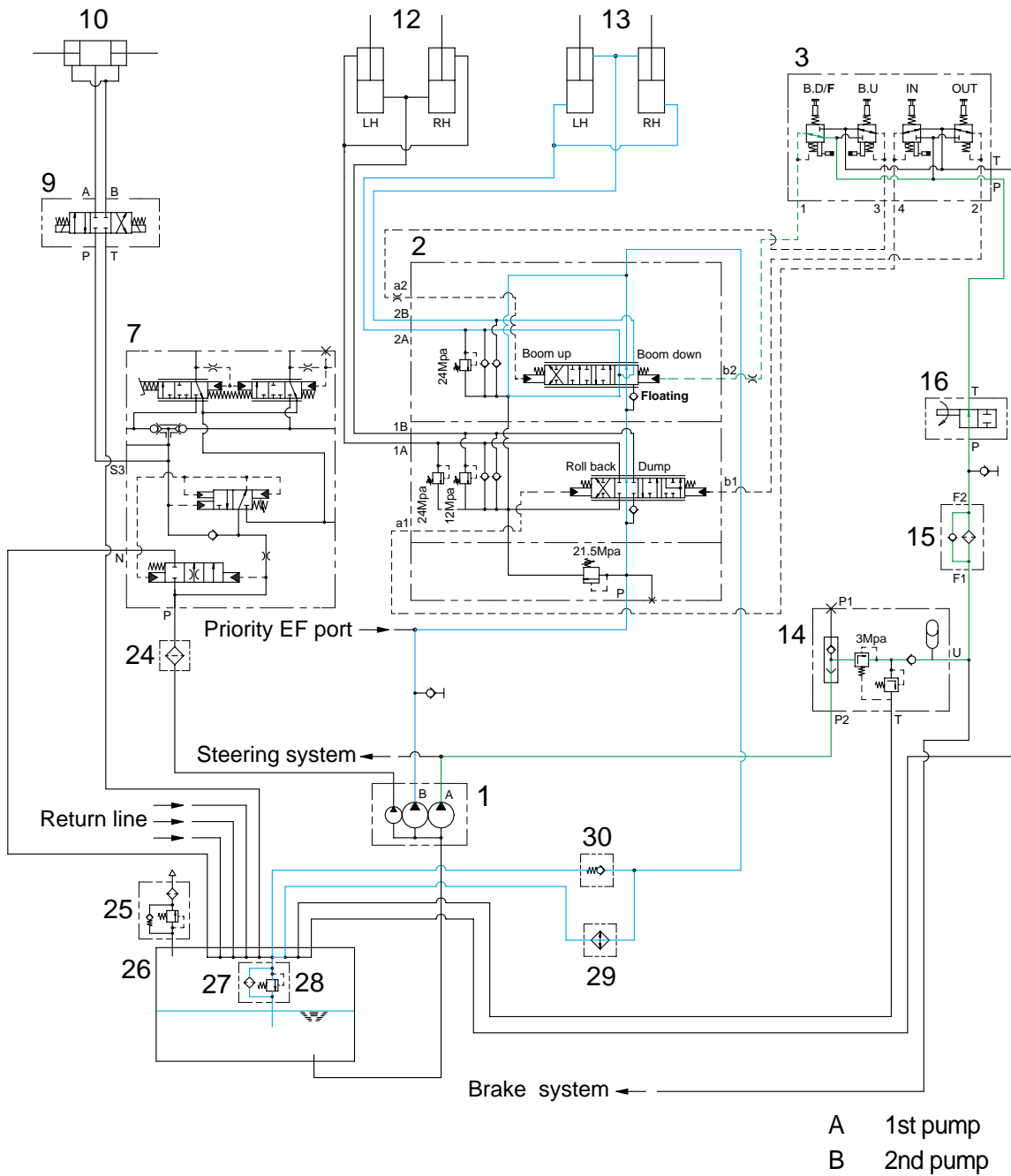

- When the RCV lever(3) is pushed further forward from the lower position, the pilot pressure reaches to 13~15bar, then the boom spool on the second block is moved to floating position.
- The work ports(2A), (2B) and the small chamber and the large chamber are connected to the return passage, so the boom will be lowered due to it's own weight.
- In this condition, when the bucket is in contact with the ground, it can be move up and down in accordance with the shape of the ground.

4) WHEN THE RCV LEVER IS IN THE DUMP POSITION

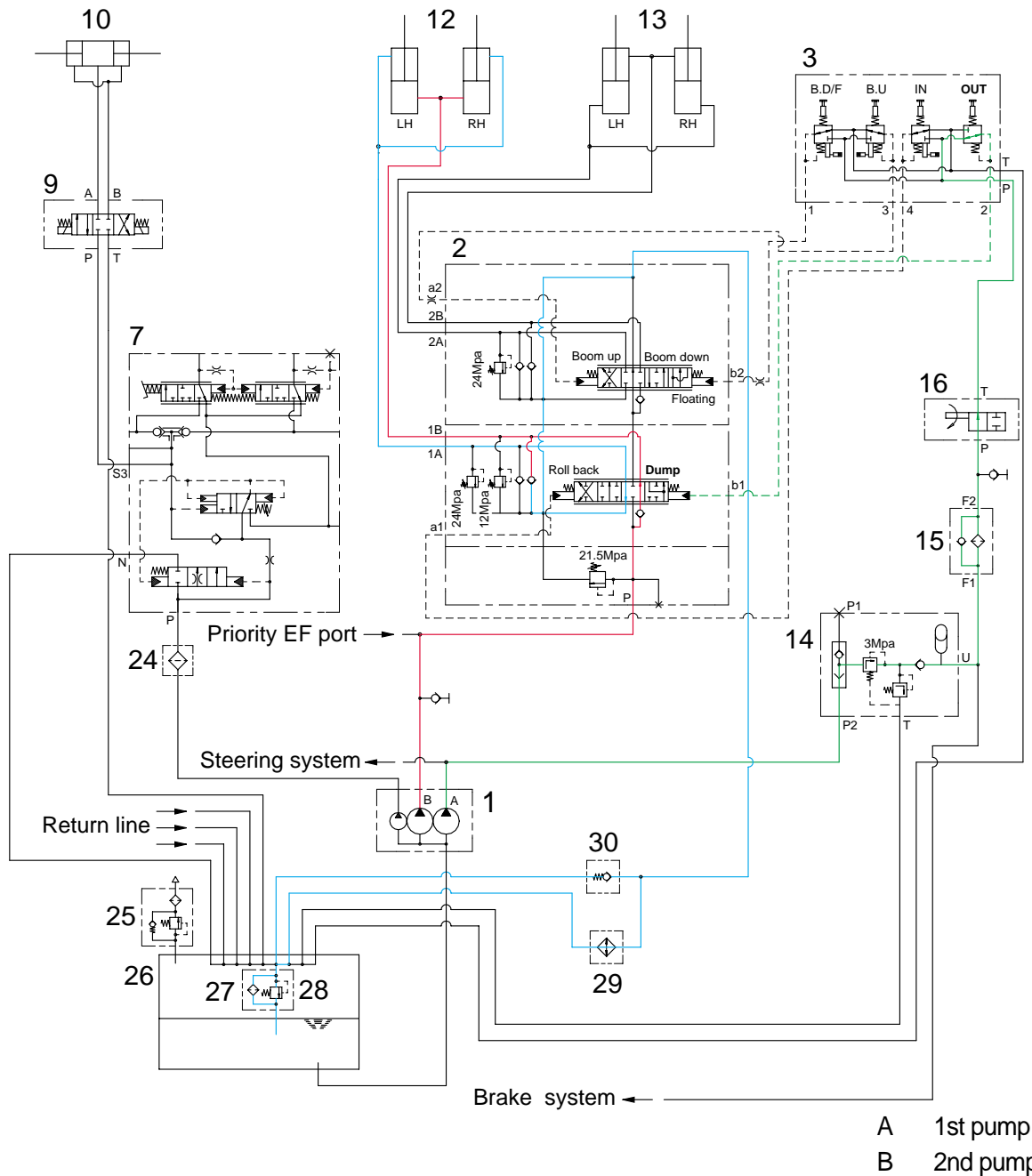

- If the RCV lever(3) is pushed right, the bucket spool on the first block is moved to dump position by pilot oil pressure from port 2 of RCV.
- And the RCV lever(3) is pushed further right, the bucket spool is moved to regenerative position.
For detail operation, refer to 6-28 page.
- The oil from main pump(1) flows into main control valve(2) and then goes to the small chamber of bucket cylinder(12) by pushing the load check valve of the bucket spool.
- The oil at the large chamber of bucket cylinder(12) returns to hydraulic tank(26) through the bucket spool.
- When this happens, the bucket is dumped.
- When the dumping speed of bucket is faster, the oil returned from the large chamber of bucket cylinder combines with the oil from the pump, and flows into the small chamber of the cylinder.
- This prevents cylinder cavitation by the negative pressure when the pump flow cannot match the bucket dump speed.

5) WHEN THE RCV LEVER IS IN THE ROLL BACK(RETRACT) POSITION

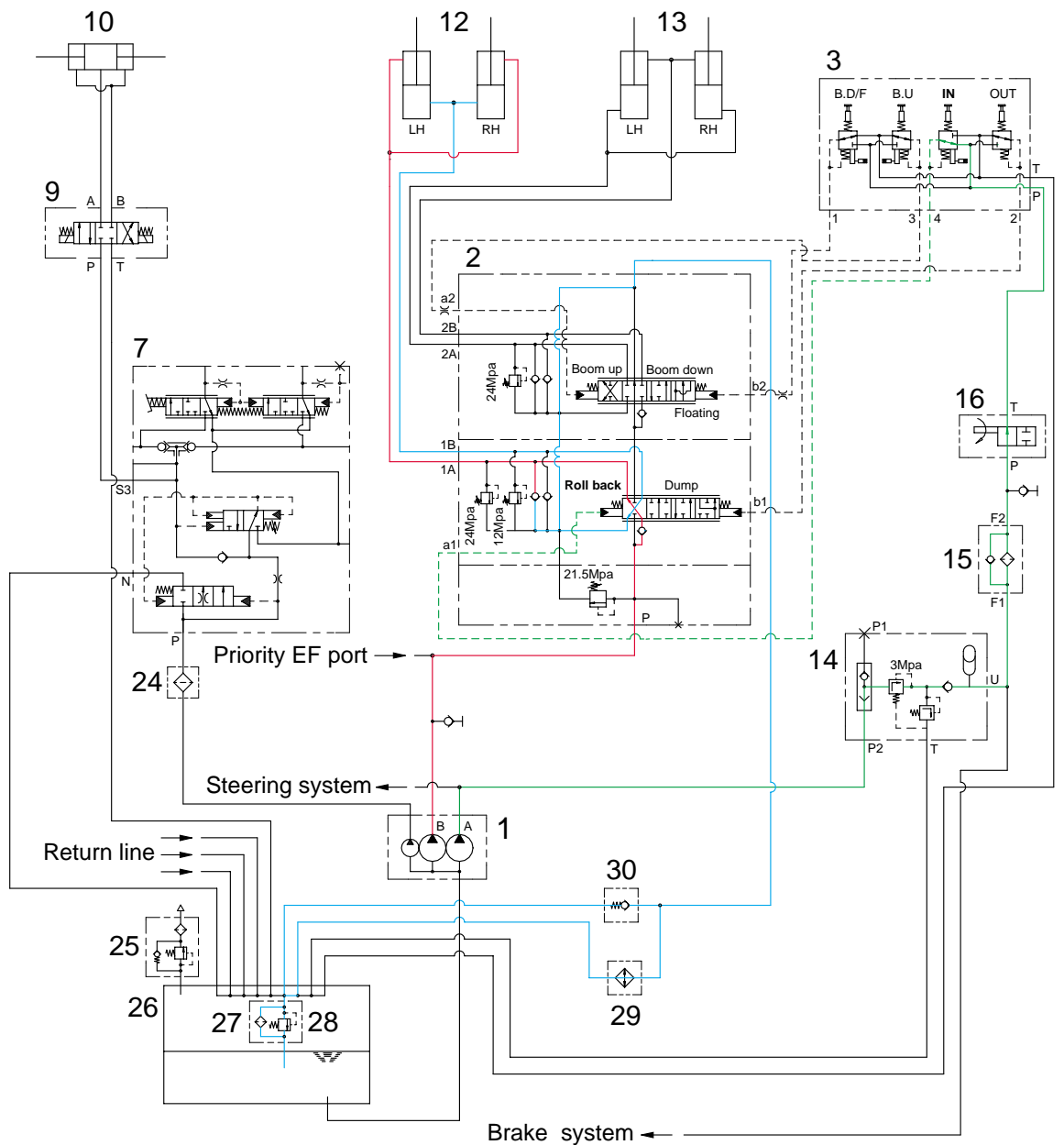

A 1st pump
B 2nd pump

- If the RCV lever(3) is pulled left, the bucket spool on the first block is moved to roll back position by pilot oil pressure from port 4 of RCV.
- The oil from main pump(1) flows into main control valve(2) and then goes to the large chamber of bucket cylinder by pushing the load check valve of the bucket spool.
- The oil at the chamber of bucket cylinder(12) returns to hydraulic tank(26) through the bucket spool.
- When this happens, the bucket roll back.
- When the rolling speed of bucket is faster, the return oil from the small chamber of bucket cylinder combines with the oil from the pump, and flows into the large chamber of the cylinder. This prevents cylinder cavitation by the negative pressure when the pump flow cannot match the bucket rolling speed.

6) WHEN THE RCV LEVER IS IN THE HOLD POSITION

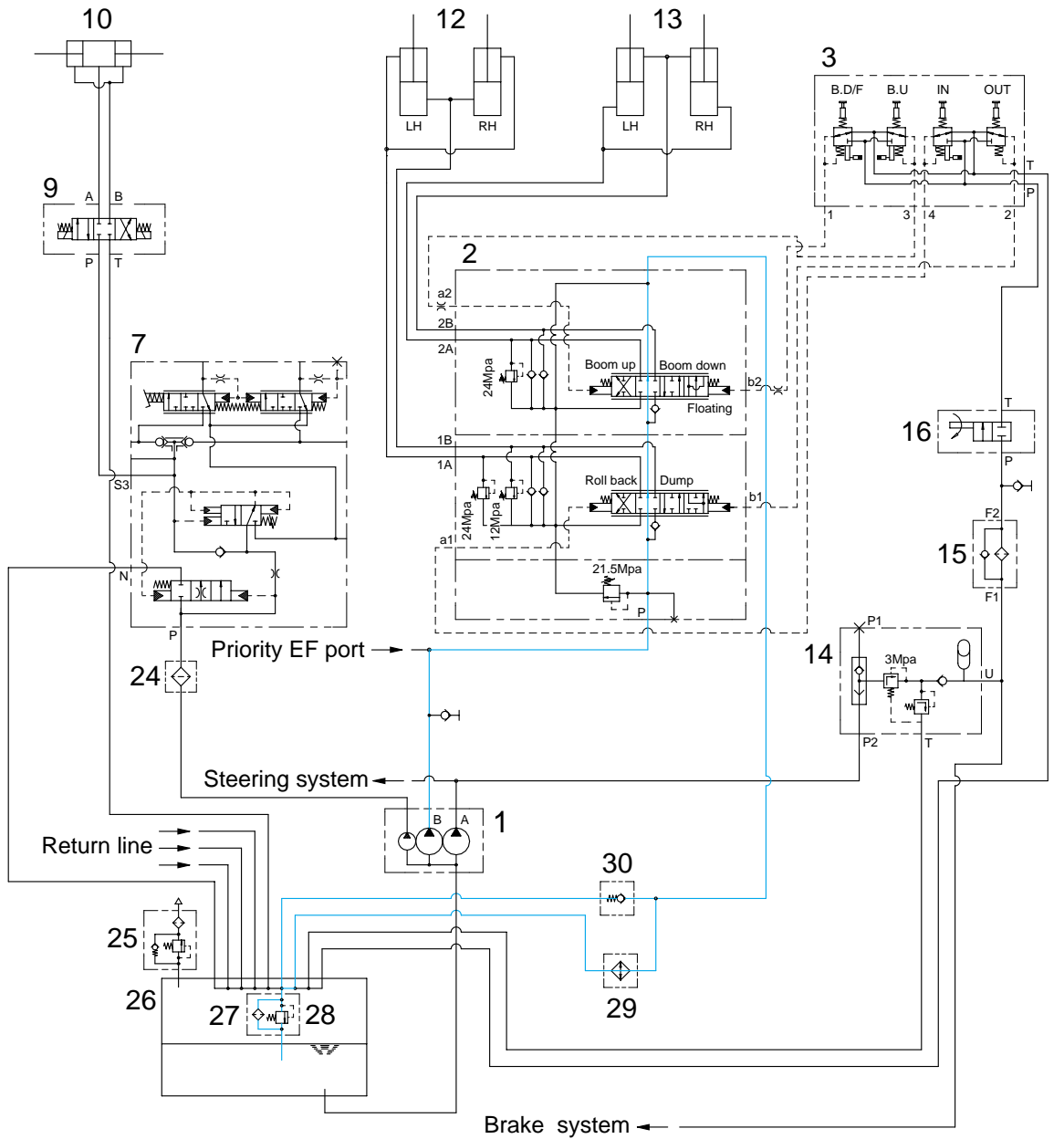

- The oil from main pump(1) flows into main control valve(2).
- In this time, the bucket spool and the boom spool are in neutral position, then the oil supplied to main control valve(2) returns into hydraulic tank(26) through center bypass circuit of each spool.
- In this condition, each cylinder keeps the neutral position, so the boom and the bucket is held.

4. MAIN PUMP OPERATION

1) STRUCTURE

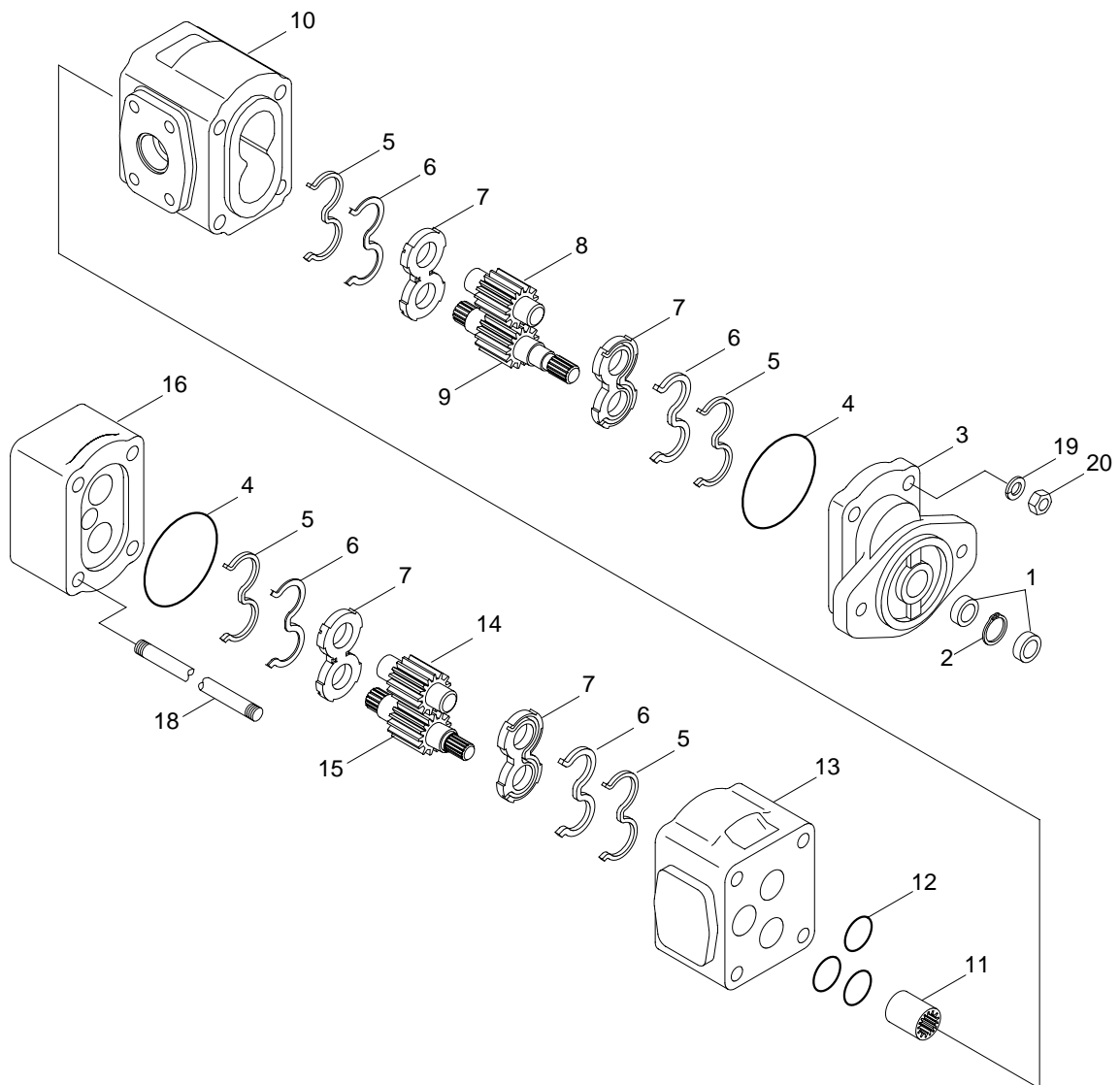

- | | | | | | |
|---|---------------|----|------------------|----|-----------------|
| 1 | Shaft seal | 8 | Driven gear | 14 | Driven gear |
| 2 | Circlip | 9 | Drive gear | 15 | Drive shaft |
| 3 | Flange | 10 | Front body | 16 | Cover |
| 4 | O-ring | 11 | Splined coupling | 18 | Stud assy |
| 5 | Seal | 12 | O-ring | 19 | Serrated washer |
| 6 | Seal | 13 | Center body | 20 | Nut |
| 7 | Balance plate | | | | |

2) OPERATION

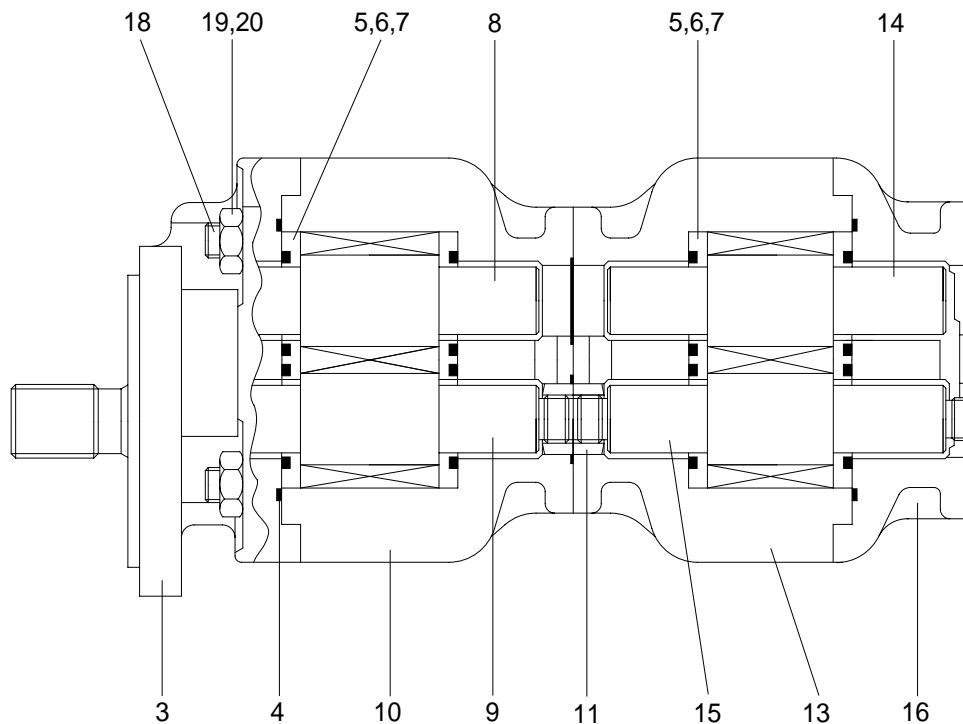

The main hydraulic pump is a fixed displacement gear type pump. The pump is drive at engine speed by the transmission. The pump shafts are supported by balance plates(7), flange(3), front body(10), center body(13) and cover(16).

As the drive gear(9) and shaft(15) turns the driven gears(8, 14), the gear teeth come out of mesh. Oil flows from the hydraulic tank through the inlet into the cavity between the gear teeth. As the gears continue to rotate, the oil becomes trapped between the gear teeth and the balance plates(7).

The trapped oil is then carried to the pump outlet. Oil is forced out the outlet to supply the hydraulic function. As the gears re-mesh, they form a seal to prevent oil from flowing between the gears and back to the inlet.

The pump uses outlet pressure oil to load the balance plates(7) against the gear faces. This controls internal leakage to maintain pump displacement.

Outlet pressure fills the area bounded by the seals(5, 6) to force the pressure plate against the high pressure area or the gear faces. Pump shaft lubrication is achieved by routing outlet pressure oil into the area between the gear shafts and the balance plates. The oil is collected at the end of the shafts in the hollow areas in the port and flange plates and routed back to return.

5. REMOTE CONTROL VALVE

1) STRUCTURE

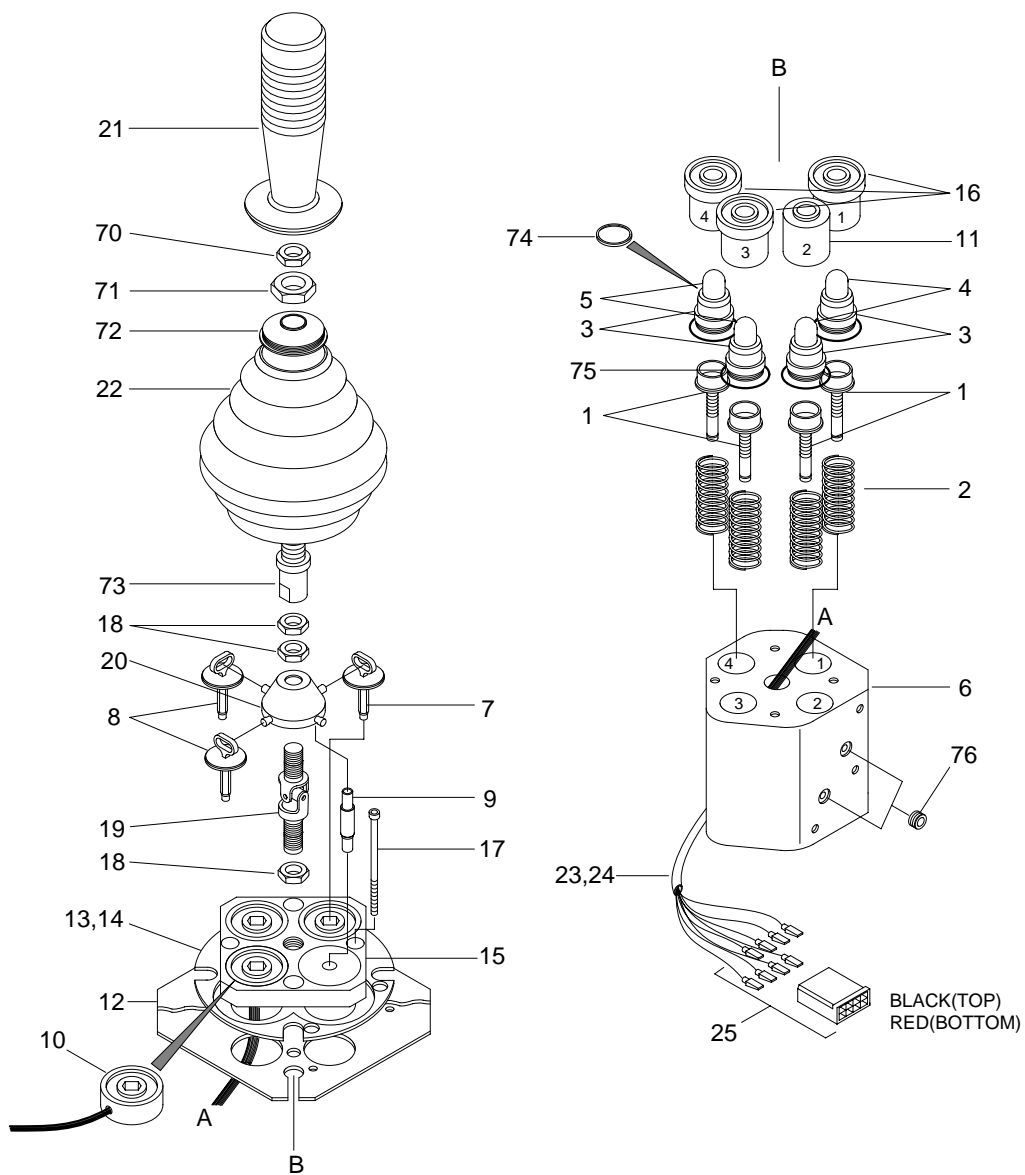

- | | | | | | |
|----|----------------------------|----|------------------------|----|-----------------------|
| 1 | Spring pack | 12 | Mounting plate | 23 | Insulation tube |
| 2 | Spring | 13 | Boot retaining plate | 24 | Cable tie |
| 3 | Plunger guide & seals assy | 14 | Screw | 25 | Connector assy |
| 4 | Plunger assy | 15 | Magnet retaining plate | 70 | Nut |
| 5 | Plunger assy | 16 | Prefeel cage assy | 71 | Nut |
| 6 | Body kit | 17 | Screw | 72 | Boot retaining collar |
| 7 | Prefeel kit | 18 | Nut | 73 | Handle adapter |
| 8 | Prefeel kit | 19 | Universal joint | 74 | Wiper seal |
| 9 | Spindle | 20 | Lever assy | 75 | O-ring |
| 10 | Hold coil | 21 | Handle assy | 76 | Plug |
| 11 | Spindle guide | 22 | Rubber boot | | |

2) OPERATION

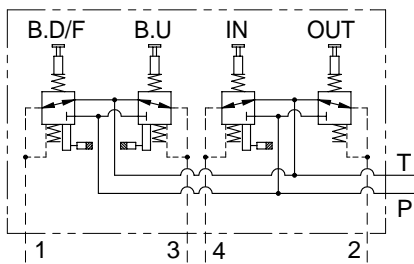
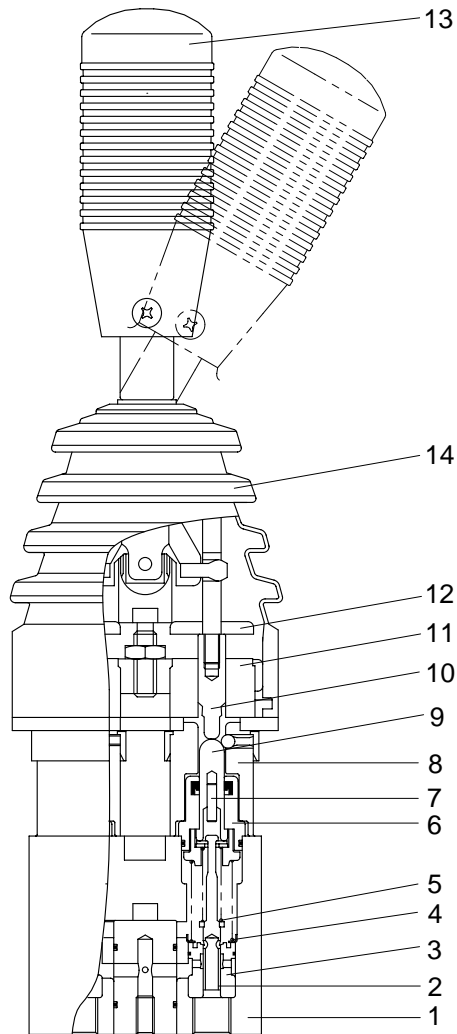

HYDRAULIC CIRCUIT

Port	Port name	Port size
1	Boom down	1/4 BSPP
2	Bucket dump	1/4 BSPP
3	Boom raise	1/4 BSPP
4	Bucket crowd	1/4 BSPP
P	Supply pressure	1/4 BSPP
T	Tank	1/4 BSPP

- | | | | | | |
|---|-------------------------|----|----------------------|----|----------------|
| 1 | Aluminum body | 6 | Plunger guide | 11 | Hold coil |
| 2 | Pressure reducing spool | 7 | Roll pin | 12 | Armature plate |
| 3 | Pressure reducing body | 8 | Prefeel ball carrier | 13 | Control lever |
| 4 | Return spring | 9 | Plunger | 14 | Rubber boot |
| 5 | Metering spring | 10 | Prefeel spindle | | |

(1) Neutral position

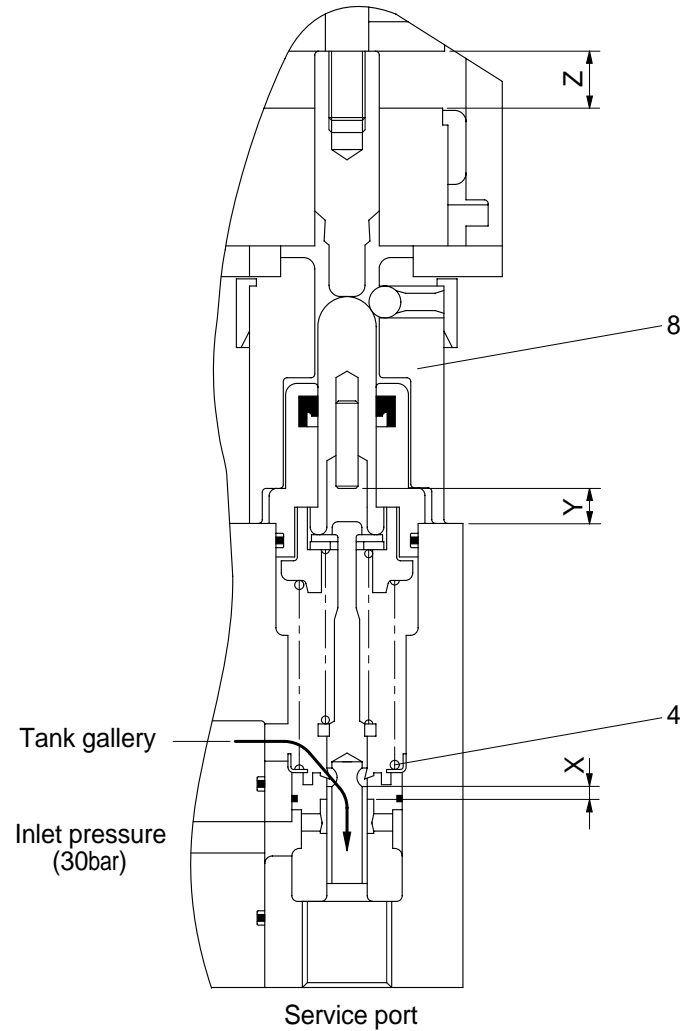

The rubber boot(14) fitted between the control lever(13) and the valve protects the working parts from external contamination. The return spring(4) holds the plunger(8) in its most upwardly position keeping the lever vertical. In this position all four service ports are connected to the tank gallery and hence to the tank port.

(2) Metering position

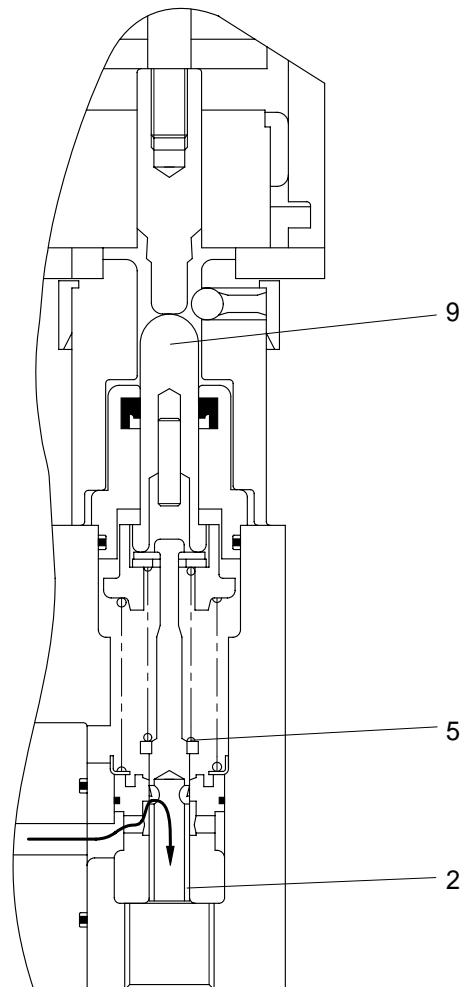

By selecting the control lever(13) the plunger(9) is progressively selected until the spool(2) deadband X is taken up. During this interval the service port is still connected to the tank gallery. Any further selection of the control lever(13) will ;

- ① Cause the four metering holes in the spool(2) to open slightly, allowing pressure to be raised at the service port. This increase in pressure then counteracts the load produced by the metering spring(5) closing off the opening until an equilibrium is maintained. The pressure raised at the service port is proportional to the rate of the metering spring. The initial jump in pressure is caused by the preload in the metering spring(5) and can be altered as required simply by adjusting the shimming.
- ② Cause the service port to shut off to the tank gallery.

(3) End of metering

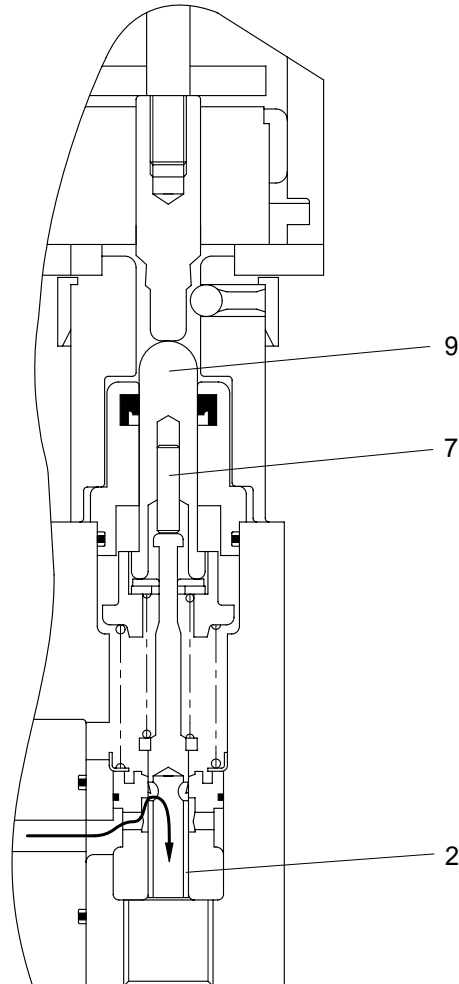

After the plunger(9) has been displaced a distance of $X+Y$, the plunger roll pin(7) is just contacting the top of the spool(2). Any further selection of the control lever(13) will cause the four metering holes in the spool(2) to open independently of the pressure.

Thus any selection of the control lever(13) past $X+Y$ will cause the service pressure to increase immediately to inlet pressure.

(4) Fully selected

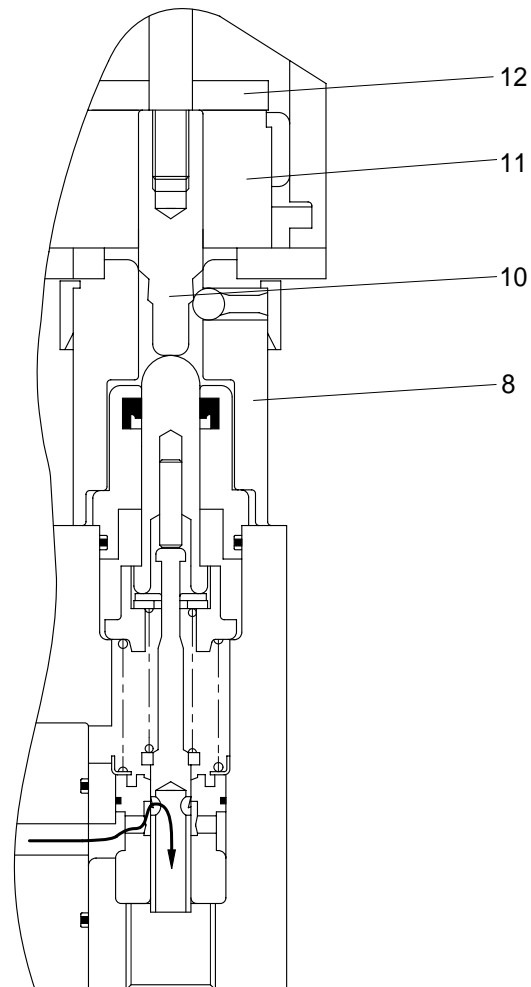

Selecting the control lever(13) now will maintain the service port pressure at inlet until the armature plate(12) contacts on the hold coil(11). However, just prior to this, the ramp on the prefeel spindle(10) reacts against the three springs in the prefeel ball carrier(8).

This produces a sharp increase in operator load(Prefeel), ensuring that the service is not accidentally selected through to detent.

6. MAIN CONTROL VALVE

1) STRUCTURE(1/2)

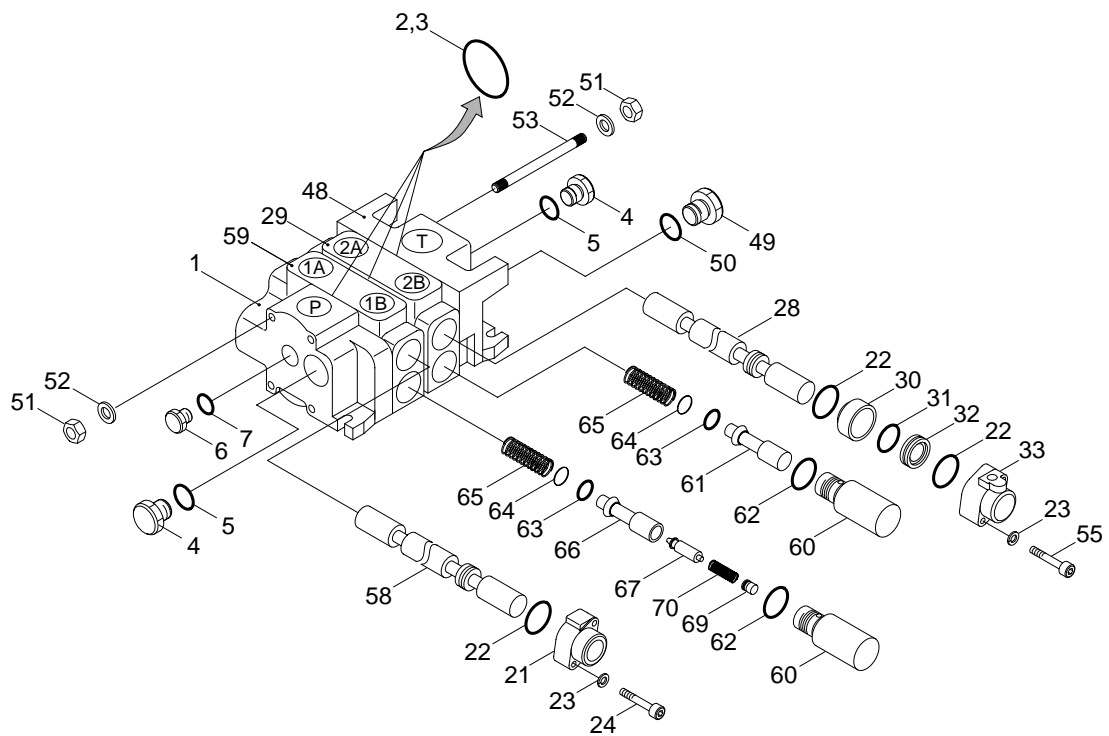

1	Inlet housing	29	Spool section	58	Spool
2	O-ring	30	Seal extension	59	Spool section
3	O-ring	31	O-ring	60	Housing
4	Plug	32	Sleeve	61	Check valve
5	O-ring	33	Cover	62	O-ring
6	Plug	48	Outlet housing	63	Back up ring
7	O-ring	49	Plug	64	O-ring
21	Cover	50	O-ring	65	Spring
22	O-ring	51	Hexagon nut	66	Check valve
23	Lock washer	52	Washer	67	Poppet
24	Bolt	53	Tie stud	69	Adjusting screw
28	Spool	55	Stop	70	Spring

STRUCTURE(2/2)

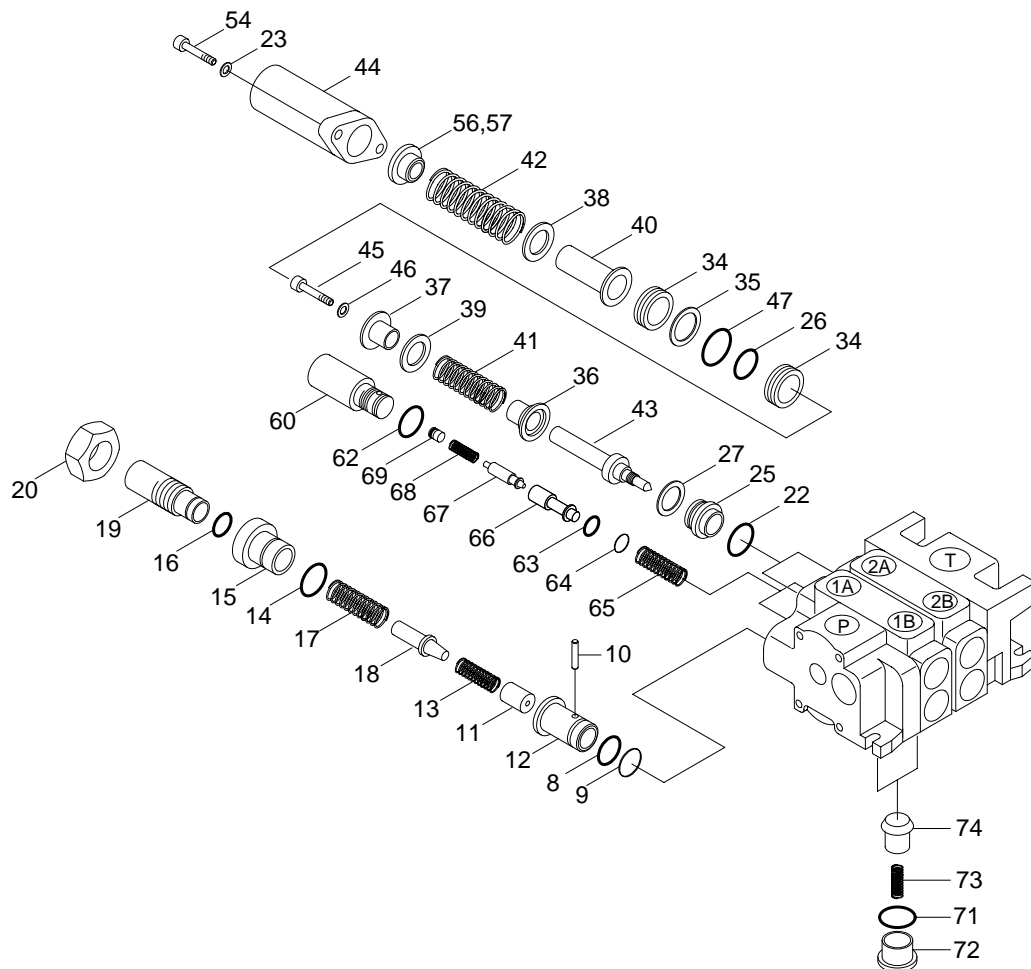

8	O-ring	26	O-ring	54	Screw
9	Back up ring	27	Shim	56	Stop
10	Pin	34	Seal retainer	57	Stop
11	Plunger	35	Circlip	60	Housing
12	Sleeve	36	Spring retainer	62	O-ring
13	Spring	37	Spring retainer	63	Back up ring
14	O-ring	38	Shim	64	O-ring
15	Pilot housing	39	Shim	65	Spring
16	O-ring	40	Spring retainer	66	Check valve
17	Spring	41	Spring	67	Poppet
18	Poppet	42	Spring	68	Spring
19	Adjusting screw	43	Spool cap	69	Adjusting screw
20	Lock nut	44	Cover	71	O-ring
22	O-ring	45	Screw	72	Cap
23	Lock washer	46	Washer	73	Spring
25	Seal retainer	47	O-ring	74	Check valve

STRUCTURE

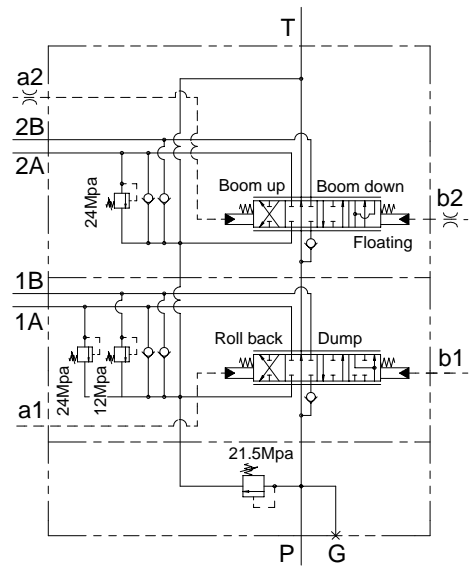
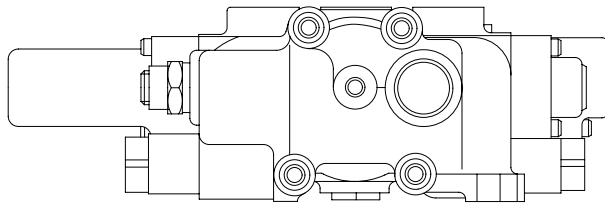
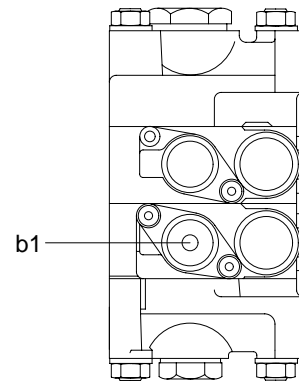
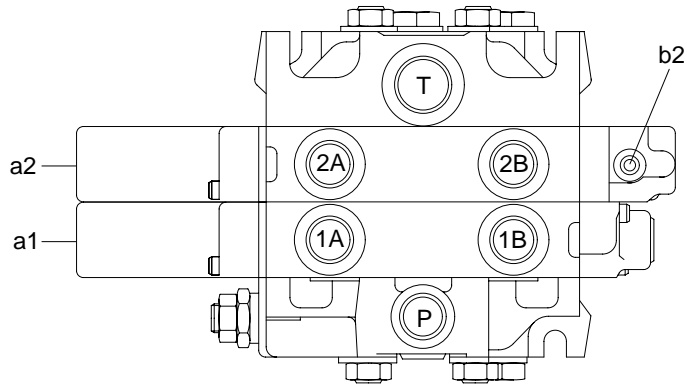

Port	Port name	Port size
P	From main pump	1 1/16UNF
T	To hydraulic tank	1 5/16UNF
1A, 1B	To bucket cylinder port	1 1/16UNF
2A, 2B	To boom cylinder port	1 1/16UNF
a1, b1	Bucket pilot port	7/16UNF
a2, b2	Boom pilot port	7/16UNF
G	Gauge port	5/16UNF

2) BOOM SECTION OPERATION

(1) Spool in neutral

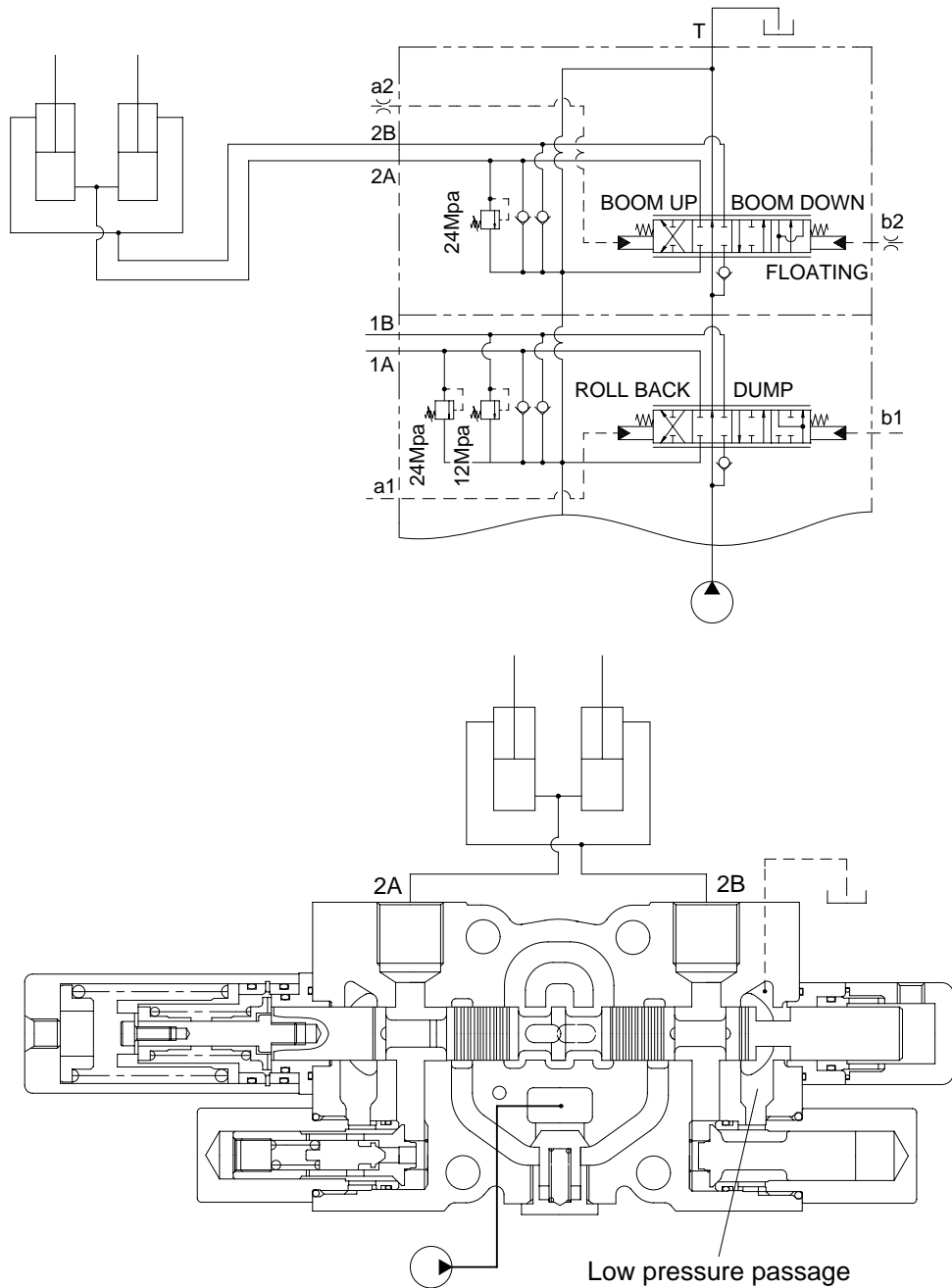

If the remote control valve is not operated, the oil supplied from the pump port passes through the neutral passage to the low pressure passage at the outlet section, and then returns to the tank port.

(2) Boom raise position

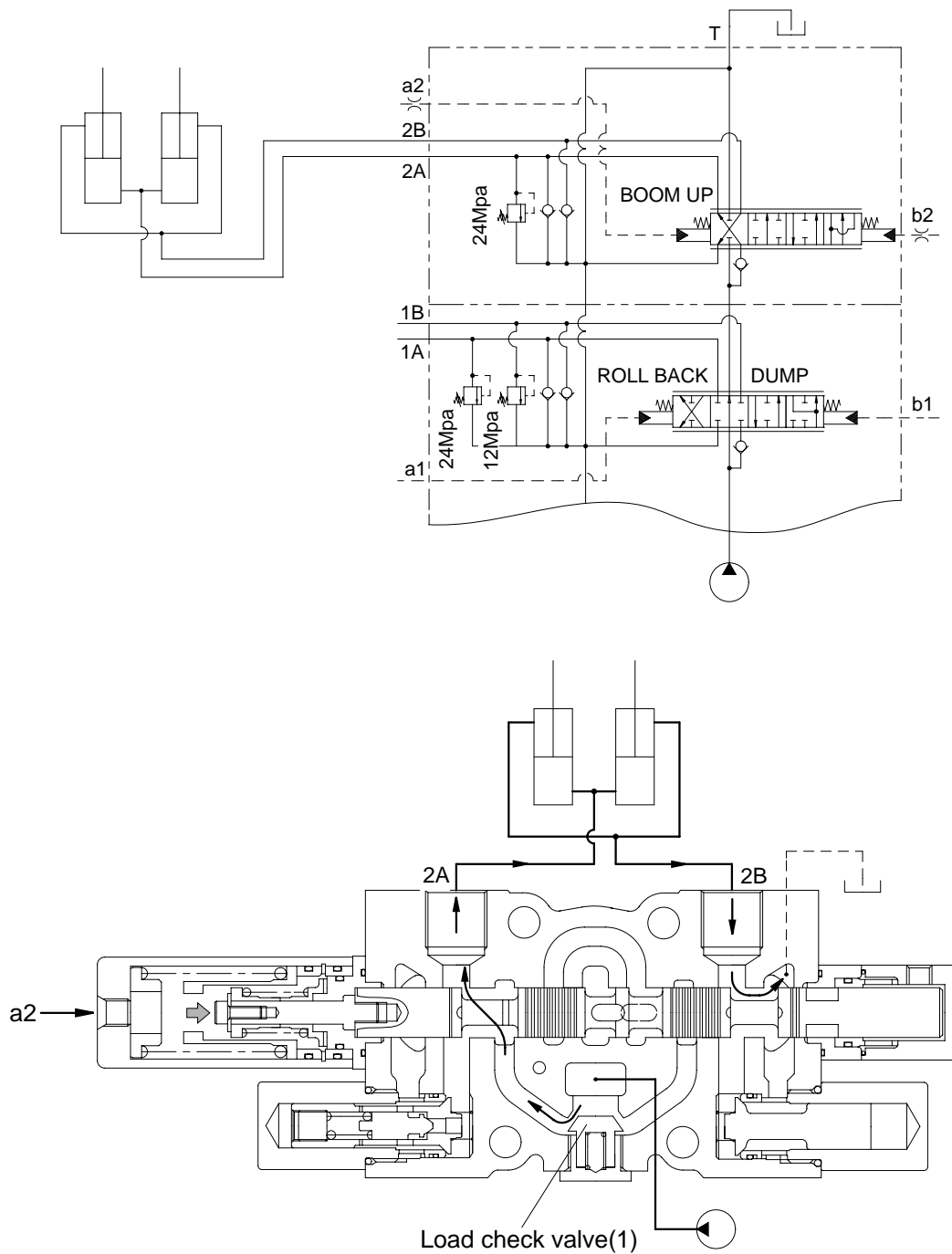

When the pilot pressure from remote control valve is supplied to the pilot port(a2), the spool moves to the right and the neutral passage is closed.

The oil supplied from the pump pushes up the load check valve(1) and flow into boom cylinder port(2A).

The pump pressure reaches proportionally the load of cylinder and fine control finished by shut off of the neutral passage.

The return oil from cylinder port(2B) flows into the tank via the low pressure passage.

(3) Boom lower position

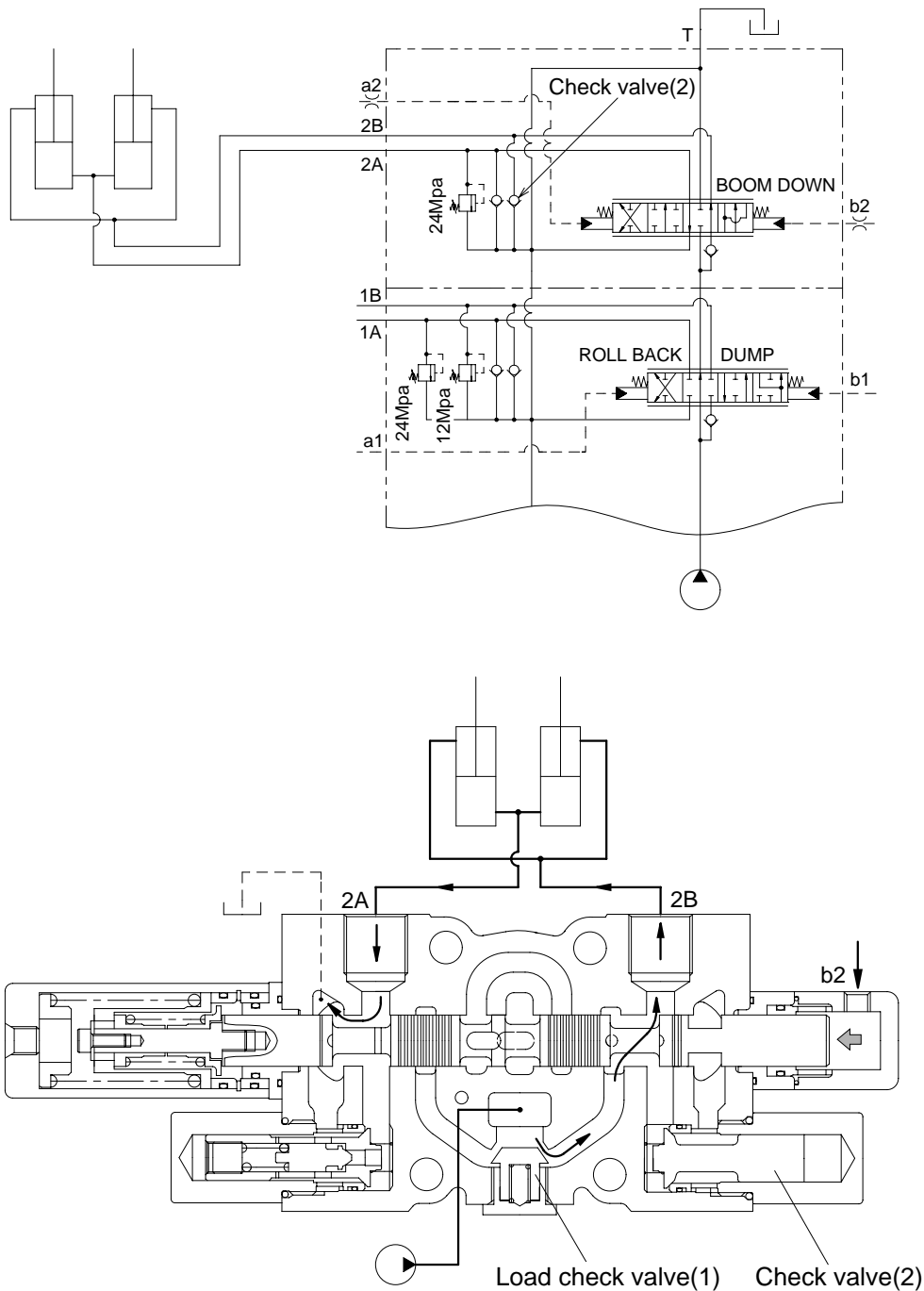

When the pilot pressure from remote control valve is supplied to the pilot port(b2), the spool moves to the left and the neutral passage is closed.

The oil supplied from the pump pushes up the load check valve(1) and flow into boom cylinder port(2B). The pump pressure reaches proportionally the load of cylinder and fine control finished by shut off of the neutral passage.

The return oil from cylinder port(2A) flows into the tank via the low pressure passage.

When the lowering speed of boom is faster, the return oil from the large chamber of boom cylinder combines with the oil from the pump through the check valve(2), and flows into the small chamber of cylinder. This prevents cylinder cavitation by the negative pressure when the pump flow cannot match the boom lowering speed.

(4) Boom float position

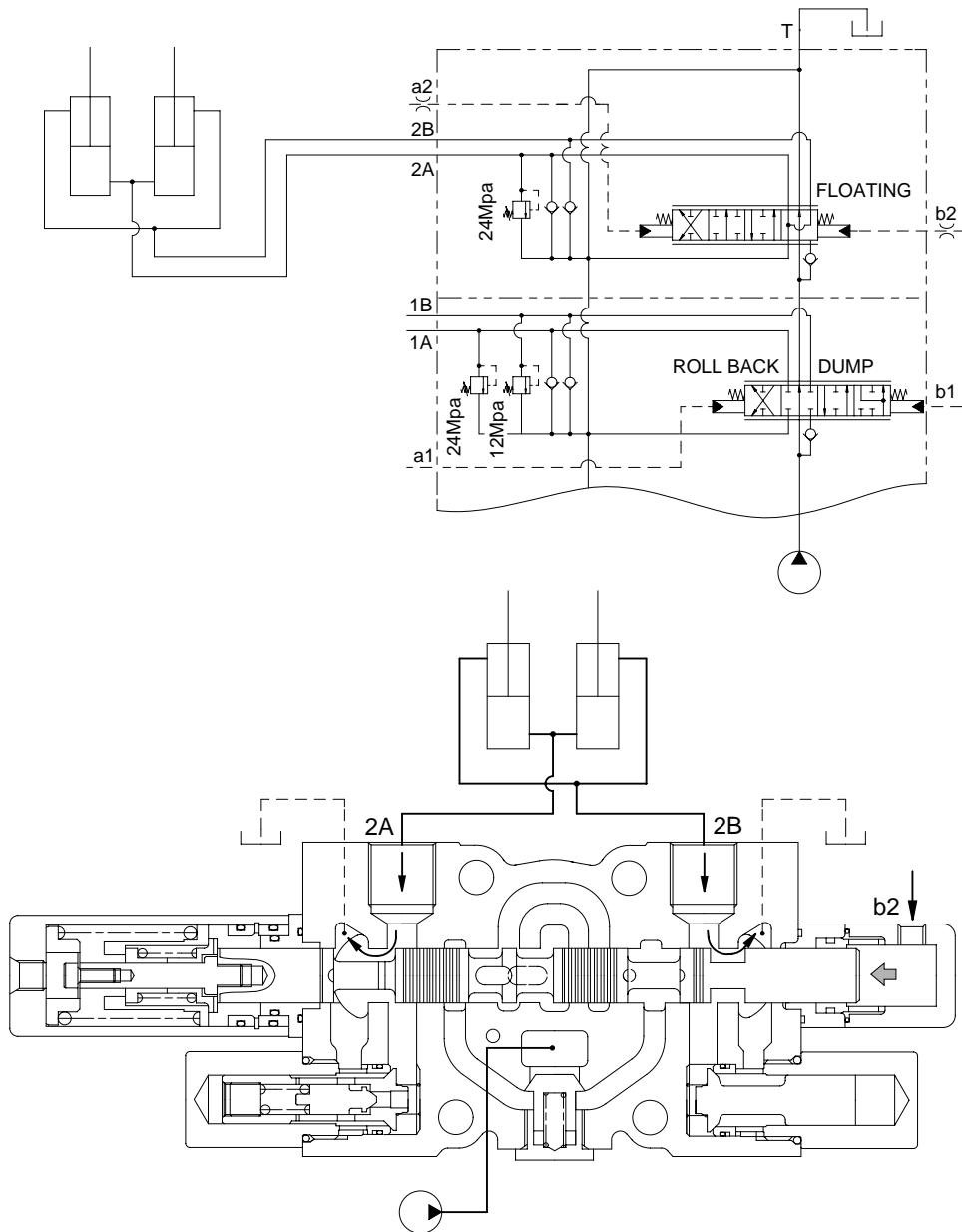

If the remote control lever pushes further more, the pilot pressure from remote control valve rises over 13-15bar and then the boom lowering spool is pushed to the boom floating position, opening up the neutral passage to tank and simultaneously (2A), (2B) → T.

In float position the boom drops quickly due to its own weight.

When the bucket touches the ground and the wheeled loader is moving, the bucket raised or lowered following the unevenness of the ground due to the (2A), (2B) → T connecting.

3) BUCKET SECTION OPERATION

(1) Bucket neutral

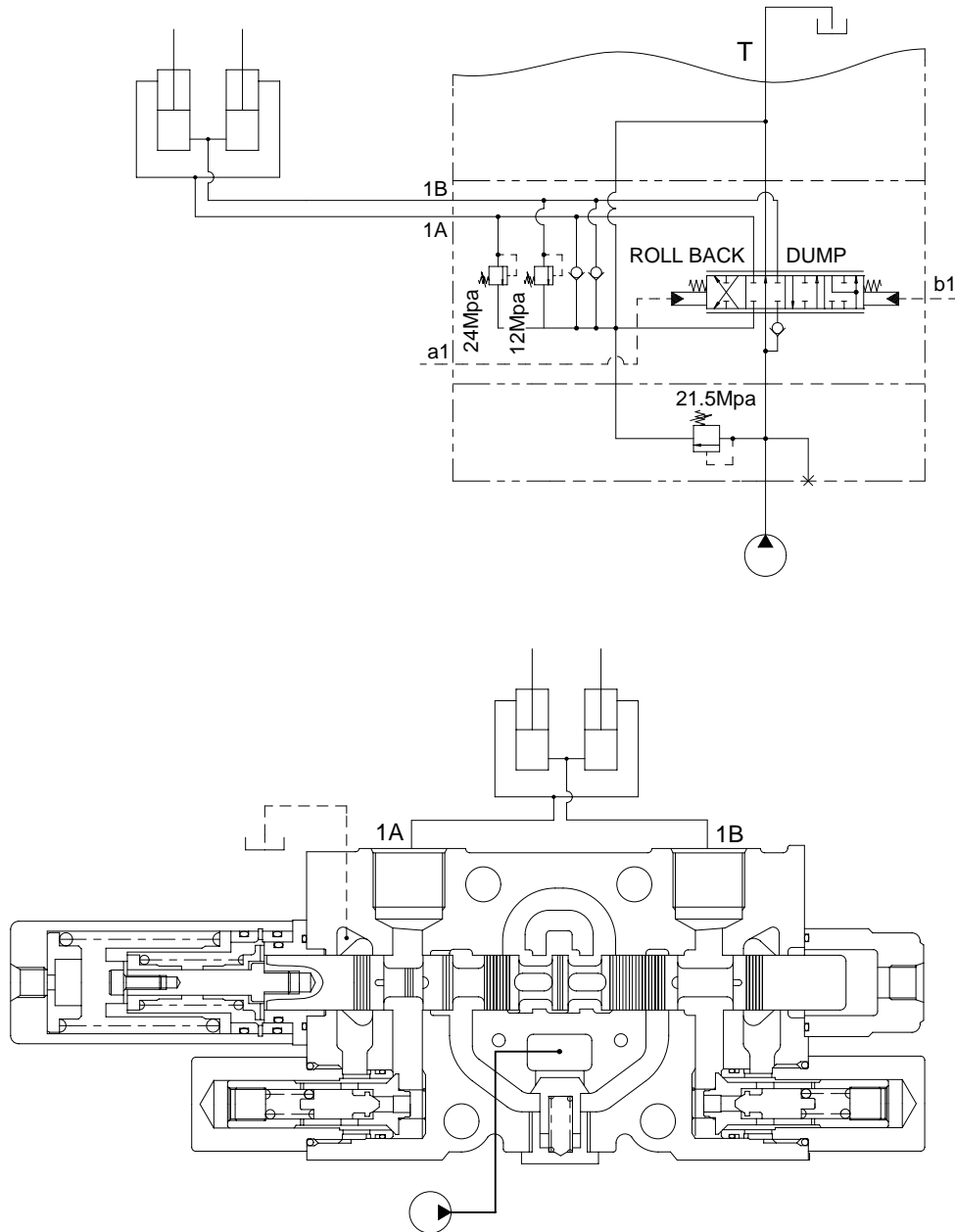

If the remote control valve is not operated, the oil supplied from the pump port passage through the neutral passage to the low pressure passage at the outlet section, and then return to the tank port.

(2) Roll back position

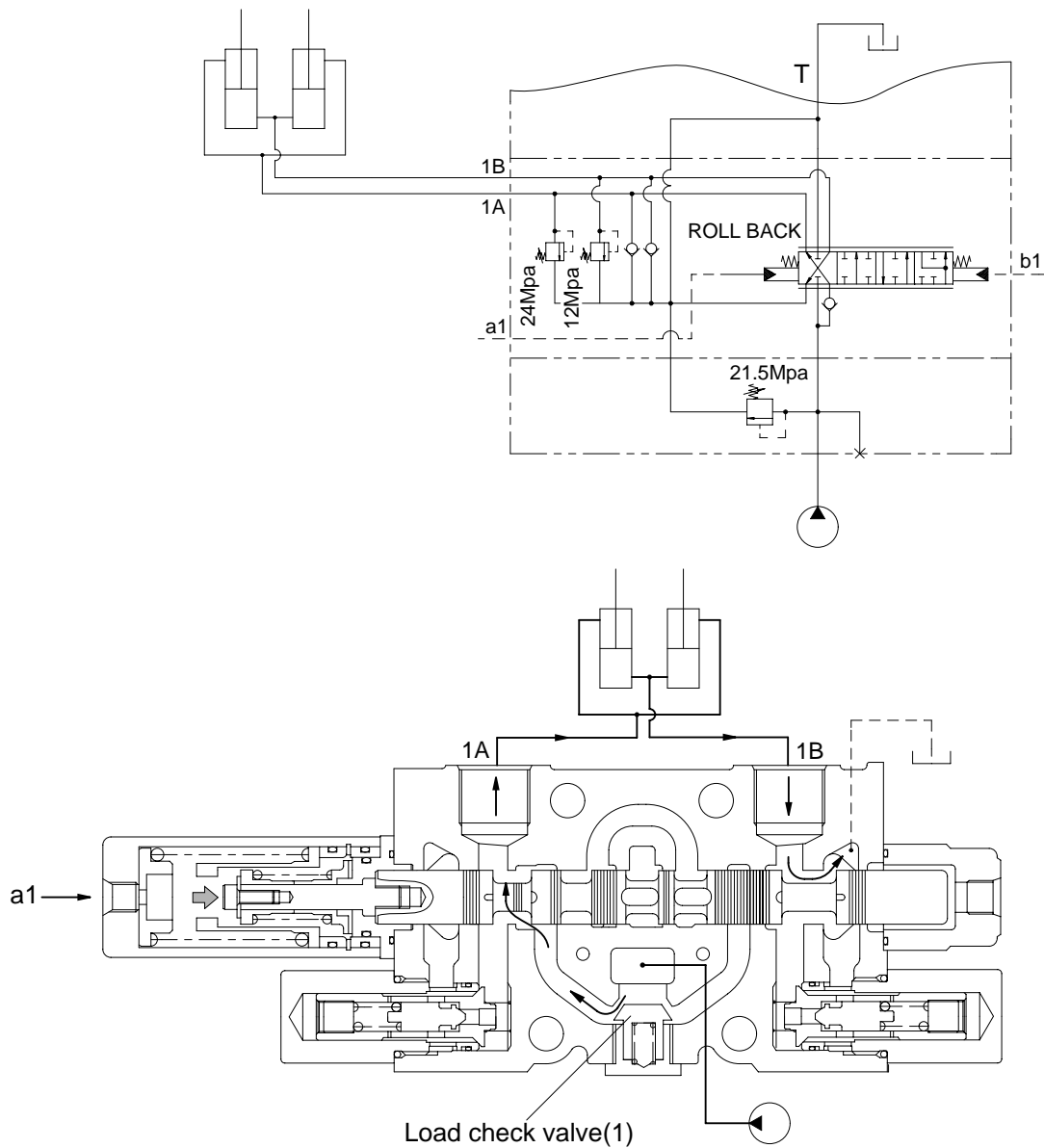

When the pilot pressure from remote control valve is supplied to the pilot port(b1), the spool moves to the left and the neutral passage is closed.

The oil supplied from the pump pushes up the load check valve(1) and flow into bucket cylinder port(1A).

The pump pressure reaches proportionally the load of cylinder and fine control finished by shut off of the neutral passage.

The return oil from cylinder port(1B) flows into the tank via the low pressure passage.

(3) Dump position

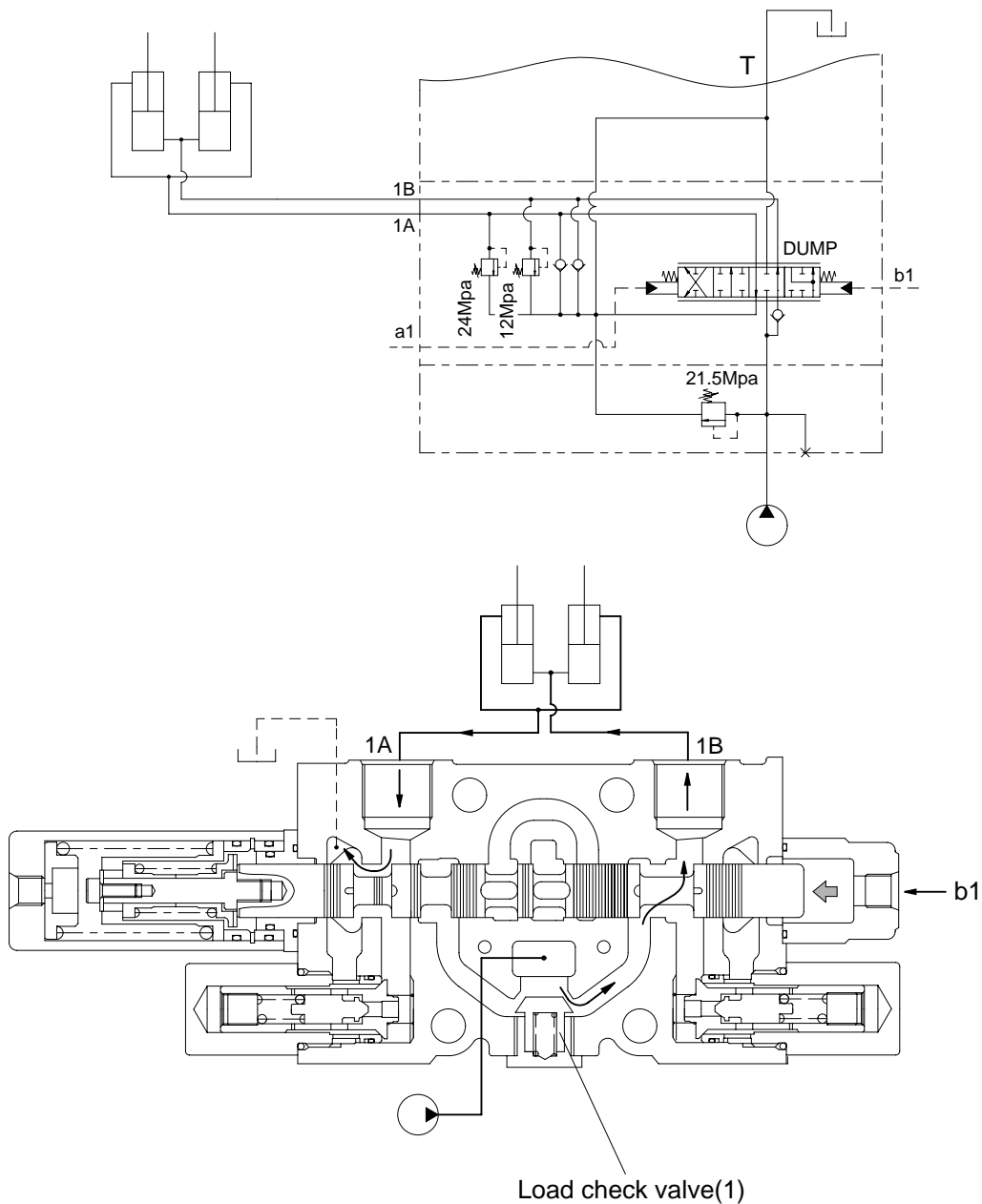

When the pilot pressure from remote control valve is supplied to the pilot port(a1), the spool moves to the right and the neutral passage is closed.

The oil supplied from the pump pushes up the load check valve(1) and flow into bucket cylinder port(1B).

The pump pressure reaches proportionally the load of cylinder and fine control finished by shut off of the neutral passage.

The return oil from cylinder port(1A) flows into the tank via the low pressure passage.

(4) Regenerative dump position

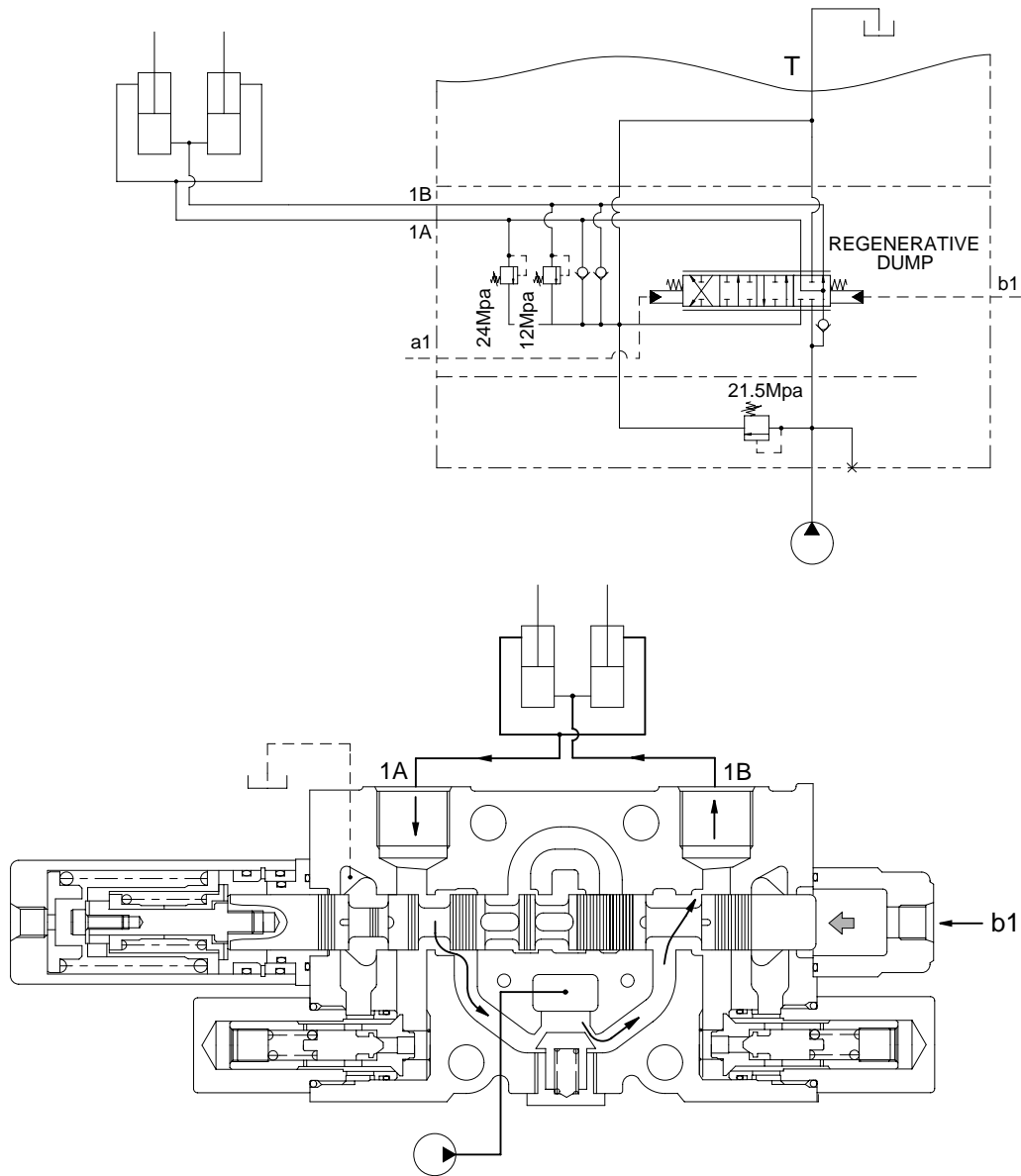

If the remote control lever pushes further more, the bucket dump spool is pushed to the regenerative dump position.

When the spool is moved to the regenerative dump position, both ends of the cylinder are connected to the pump port passage. This pressurizes both ends of the cylinder with equal pressure. Since the head end of the piston has a larger area than the rod end, a greater force is exerted to extend the cylinder. As the cylinder extends, the return oil from the rod end flows back to the valve, combines with the oil from the pump, and flows out to the head end of the cylinder. This provides a faster bucket dump cycle time but reduces the cylinder force.

4) MAIN RELIEF VALVE

- The main relief valve is installed at the inlet of the main control valve. When the oil goes above the set pressure, the relief valve drains the oil to the tank. In this way, it sets the maximum pressure in the hydraulic circuit and protects the circuit.
- The valve poppet(C) is connected via the throttle drillings(D1) and (D2) with the P port. If static pressure increases above the set pressure valve, the valve poppet(C) opens and allows oil to flow freely to tank(Y). This oil generates a pressure drop in the spring chamber of the main poppet, the closing force of the spring(Z) is cancelled, and the main poppet(A) opens to allow the pump flow to flow to tank(T). Damped opening and closing is obtained by the throttled volumetric change.

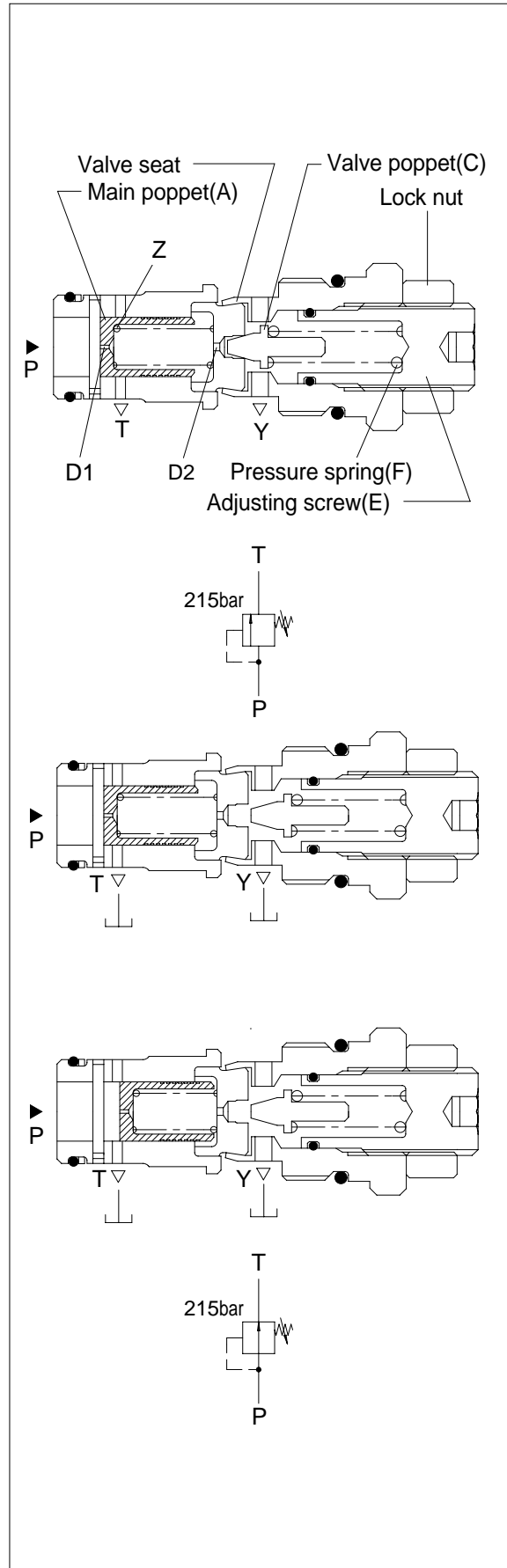

5) PORT RELIEF VALVE

- The overload relief valve (Combined relief/anticavitation valve) is in the boom cylinder and bucket cylinder circuit in the main control valve.

If shock causes any abnormally high pressure in the cylinder when the main valves is at neutral, the overload relief valve releases the abnormal pressure and protects the cylinder from damage.

- Pressure oil flows into passage(1). The oil acts against the left side of valve(2), when is held closed by spring(4).

When a shock causes pressure in any of the cylinders to rise, the increase in pressure is also sensed in passage(1). As the pressure rises above the pressure setting, the oil overcomes the force of spring(4) and valve(2) will move to the right.

Oil in passage(1) then flows past the open valve, through passage, and back to the hydraulic oil tank.

When oil pressure returns to a level below the pressure setting, spring(4) moves valve(2) to the left and onto the seat.

- If cavitation in the workport occurs, the oil pressure in the workport drop below return pressure.

With the workport pressure below return pressure, the return pressure works against the shoulder of the poppet(5), causing it to open against the spring(3).

Return pressure oil flows into the workport to prevent cylinder cavitation.

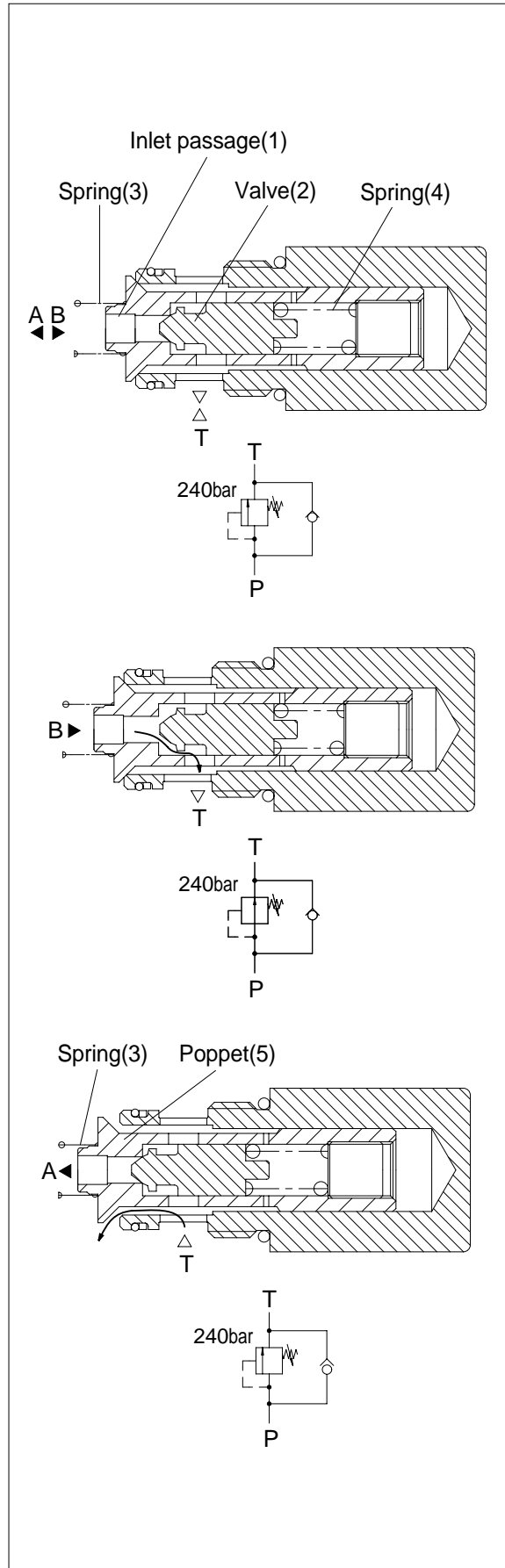

6) PRESSURE SETTING

A good pressure gage must be installed in the line which is in communication with the work port relief. A load must be applied in a manner to reach the set pressure of the relief unit.

(1) Main relief valve

- ① Loosen lock nut.
- ② Set adjusting screw to desired pressure setting.
- ③ Tighten lock nut.
- ④ Retest in similar manner as above.

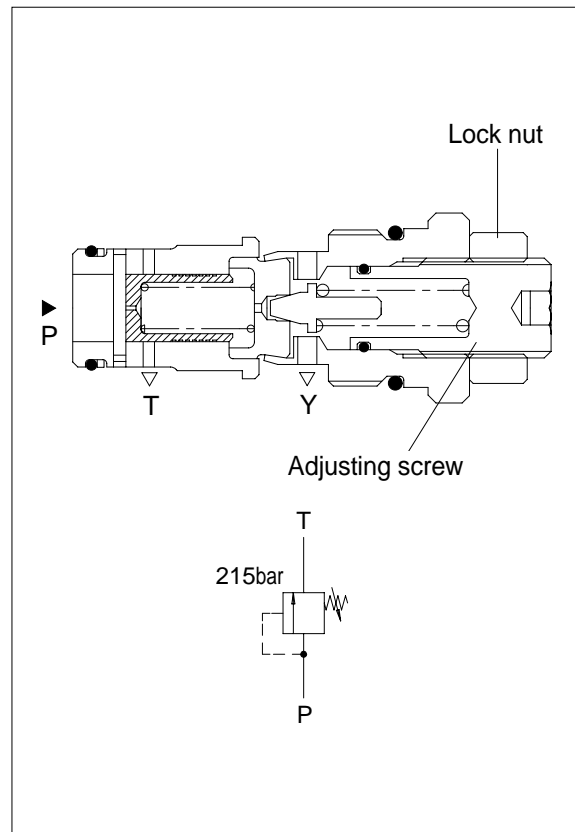

(2) Port relief valve

- ① Loosen valve housing.
- ② Set adjusting screw to desired pressure setting.
- ③ Tighten valve housing.
- ④ Retest in similar manner as above.

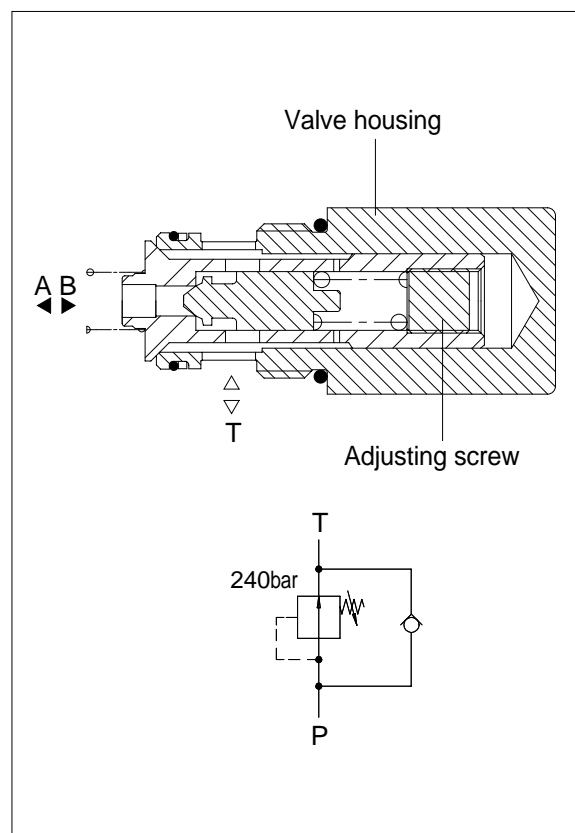

7. PILOT OIL SUPPLY UNIT

1) STRUCTURE

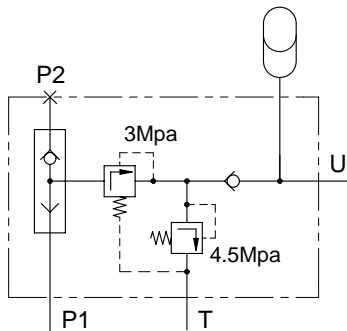
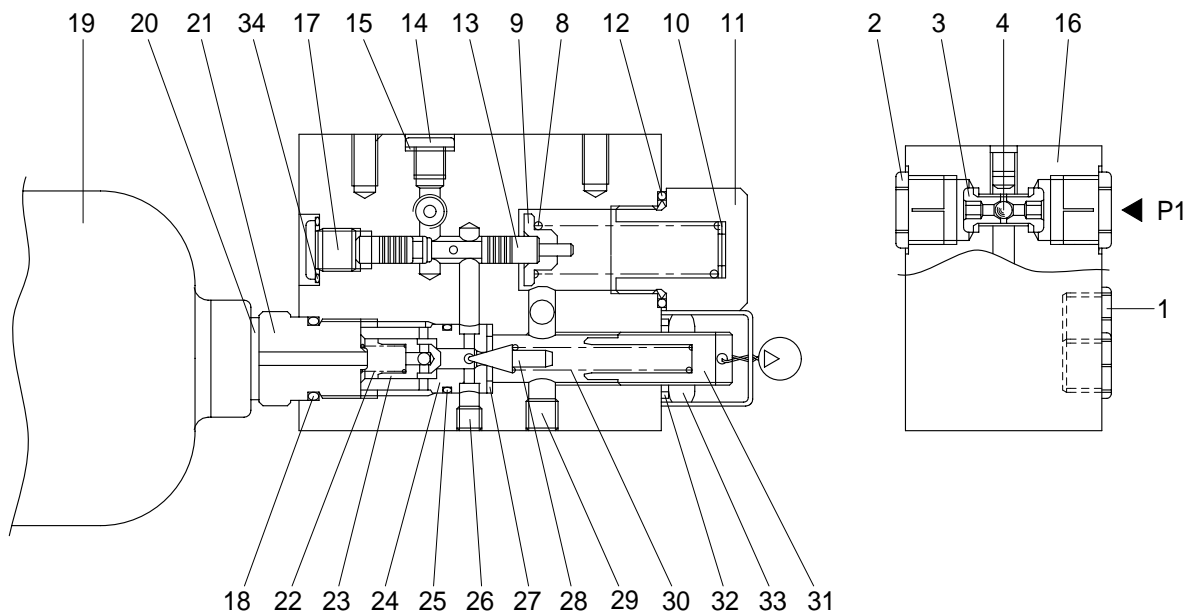

HYDRAULIC CIRCUIT

Port	Port name	Port size
P1	From main pump	3/4 UNF
P2	Plugging	3/4 UNF
U	Supply to RCV lever	9/16 UND
T	To hydraulic tank	9/16 UND

- | | | |
|----------------|------------------|--------------------|
| 1 Plug | 14 Plug | 24 Valve seat |
| 2 Plug | 15 Copper washer | 25 O-ring |
| 3 Seat | 16 Housing | 26 Plug |
| 4 Ball | 17 Plug | 27 Copper washer |
| 8 Spring | 18 O-ring | 28 Valve poppet |
| 9 Spring guide | 19 Accumulator | 29 Plug |
| 10 Shim | 20 Seal | 30 Spring |
| 11 Plug | 21 Adapter | 31 Adjusting screw |
| 12 Seal | 22 Spring | 32 Washer |
| 13 Spool | 23 Check valve | 33 Nut |

2) OPERATION

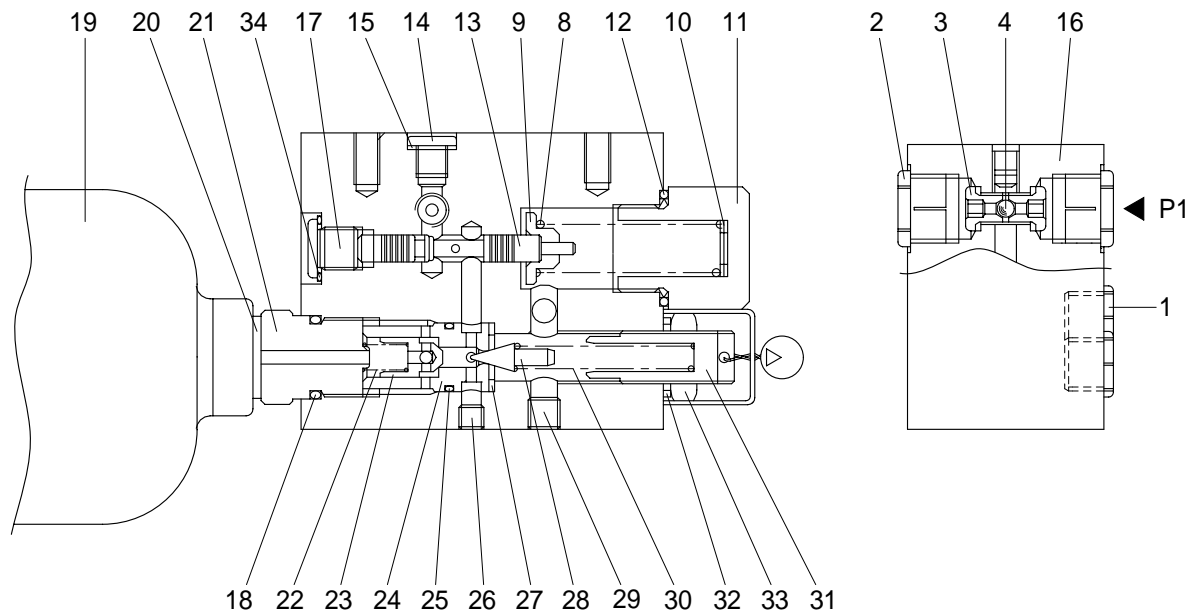

Pilot oil supply unit are a combination of valves which reduce the pressure of medium and high pressure circuits in order to supply remote control valve with a low pressure supply of oil. They basically consist of the accumulator(19), the housing(16), a seat(3), a direct operated pressure relief valve(28) and a check valve(23).

Fluid flows from the high pressure via the shuttle valve(4) through port P1 into the unit and then to the secondary circuit. The pressure is reduced to the required level by means of spool(13) and passes via the check valve(23) into the accumulator(19) thus ensuring though port U greater control power and-when necessary-emergency operation should the main circuit be switched off or become defective.

Pressure relief valve(28) protects the pilot circuit should the spool(13) fail to operate. Check valve(23) prevents the accumulator emptying into the primary circuit.

Accumulator satisfies short term peak power demands and is a source of emergency power should the main circuit pressure fail.

8. SAFETY VALVE UNIT

1) STRUCTURE

The safety valve locks or permits pilot oil flow to the main control valve operation.

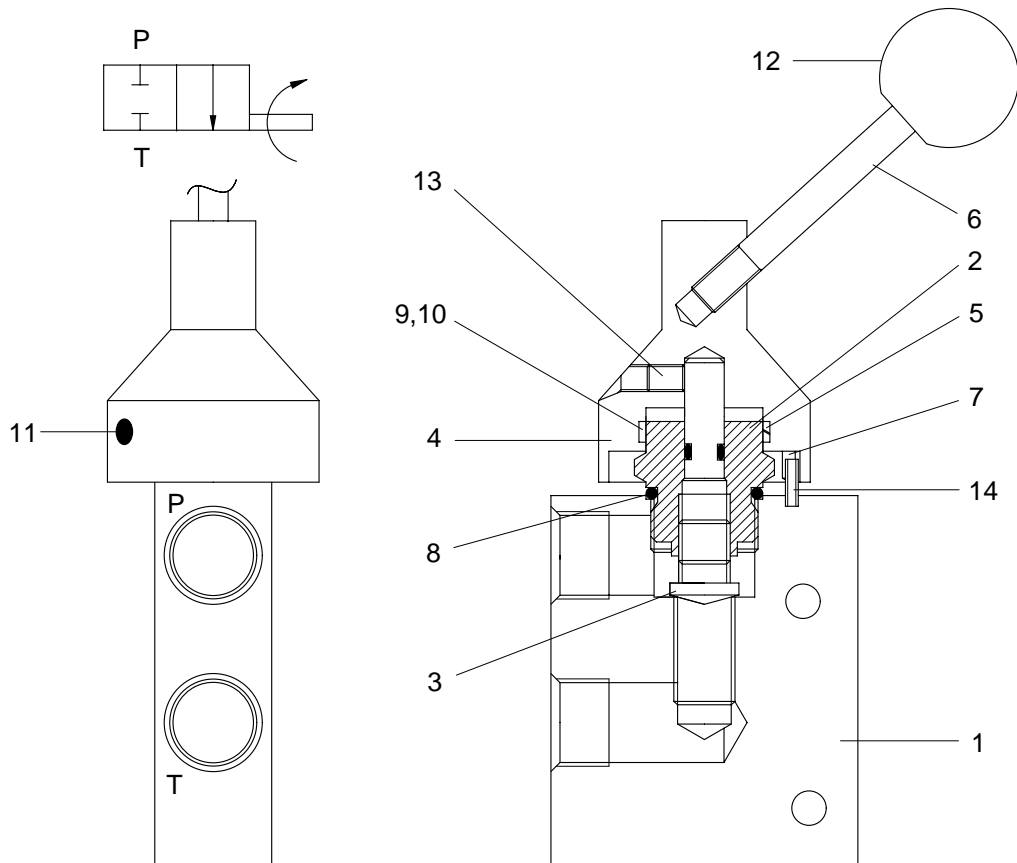

- | | | | | | |
|---|-------------|----|--------------|----|------------------|
| 1 | Body | 6 | Handle | 11 | Spring plunger |
| 2 | Retainer | 7 | Spring pin | 12 | Knob |
| 3 | Adjust stem | 8 | O-ring | 13 | Socket set screw |
| 4 | Housing | 9 | O-ring | 14 | Spring pin |
| 5 | Clutch ring | 10 | Back up ring | | |

9. BOOM AND BUCKET CYLINDER

The boom cylinders and the bucket cylinders are two unit.

The piston(12) threads on to the rod(2) and is retained by a nylon nut(18).

The piston seals against the tube(1) with glyd ring(15). Two wear rings(16) are located on each side of the piston seal.

The gland(3, the rod guide) seals against the tube with an O-ring(10). The cylinder thread seals against the rod with a lip type buffer ring(7) and a rod seal(5). A dust wiper(8) cleans the rod when it is retracted.

1) BOOM CYLINDER

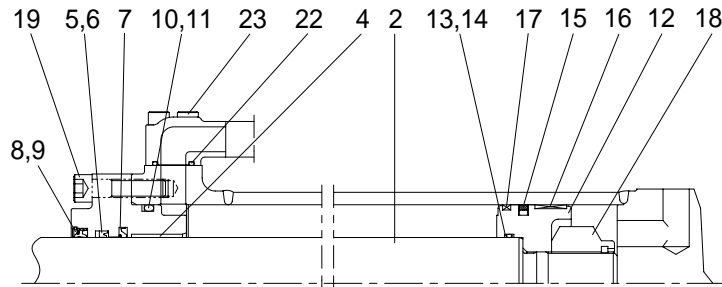
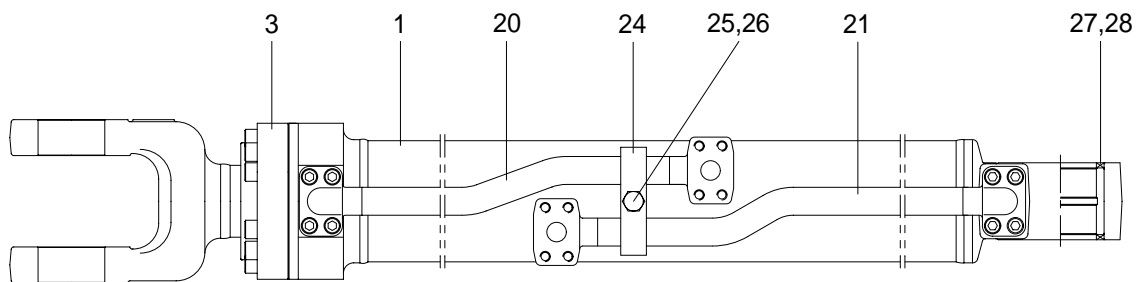

INTERNAL DETAIL

1	Tube assy	11	Back up ring	21	Pipe assy
2	Rod assy	12	Piston	22	O-ring
3	Gland	13	O-ring	23	Socket bolt
4	Bushing	14	Back up ring	24	Pipe clamp
5	Rod seal	15	Glyd ring	25	Hexagon bolt
6	Back up ring	16	Wear ring	26	Spring washer
7	Buffer ring	17	Dust ring	27	Bushing
8	Dust wiper	18	Nylon nut	28	Dust seal
9	Snap ring	19	Socket bolt		
10	O-ring	20	Pipe assy		

2) BUCKET CYLINDER

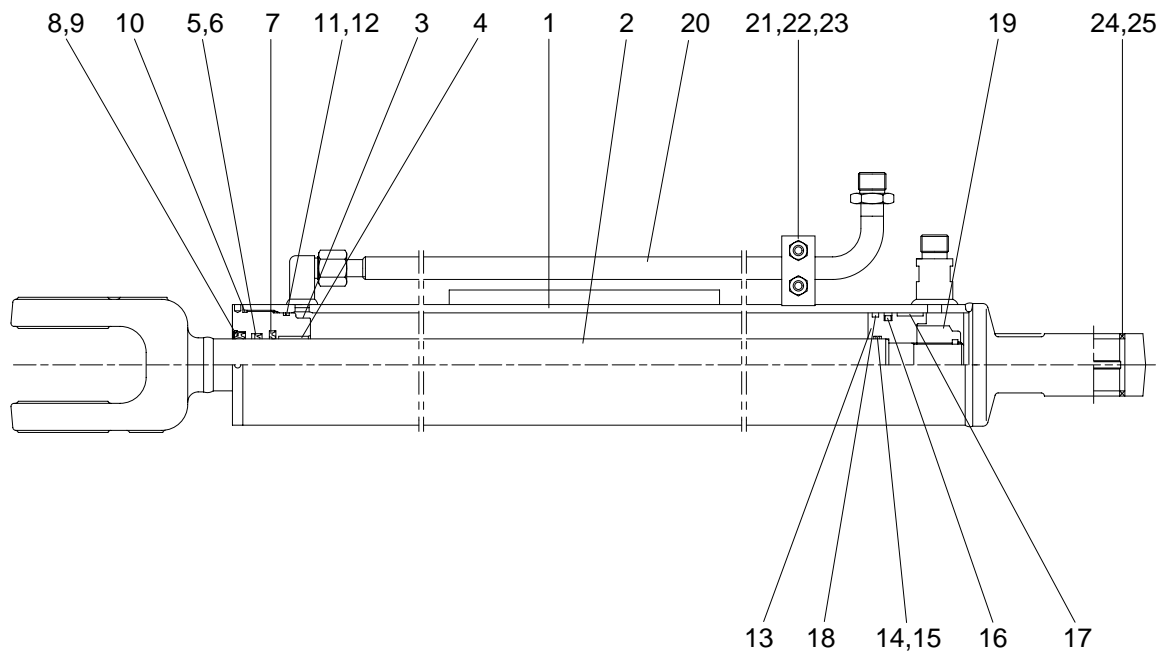

1	Tube assy	10	O-ring	19	Nylon nut
2	Rod assy	11	O-ring	20	Pipe assy
3	Gland	12	Back up ring	21	U-bolt
4	Bushing	13	Piston	22	Hexagon nut
5	Rod seal	14	O-ring	23	Spring washer
6	Back up ring	15	Back up ring	24	Bushing
7	Buffer ring	16	Piston seal	25	Dust seal
8	Dust wiper	17	Wear ring		
9	Snap ring	18	Dust ring		

3) COUPLER CYLINDER

Brake pump pressure oil enters the solenoid valve through the pressure port(P).

When the **attachment engage switch** is pressed, the spool moves to the right.

This allows pressure oil to flow out workport(A) to the center of cylinder, holding the pins(H) in the extended position. The cylinder rod ends are joined by pipe(G) to return through workport(B).

When the **attachment disengage switch** is pressed, the spool moves to the left. This allows pressure oil to flow out workport(B) to the rod ends of the cylinder, retracting the pins(H).

Return oil then flows into workport(A) and out return port(T).

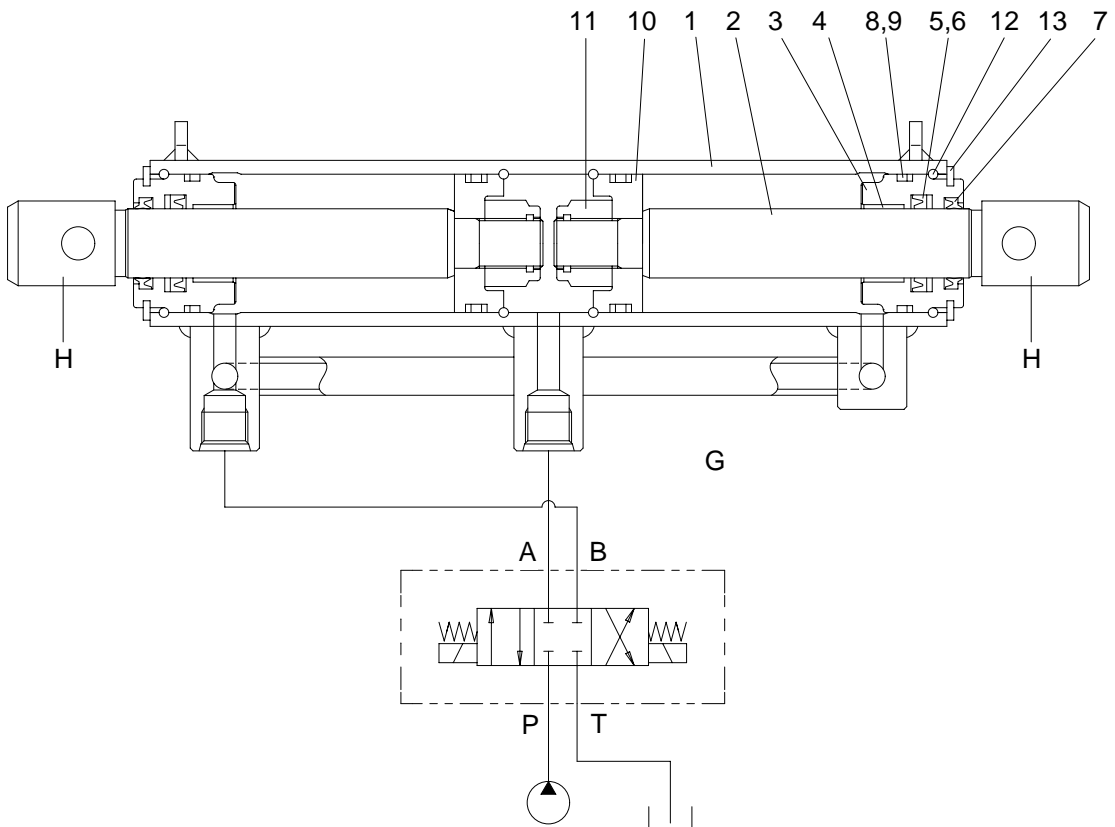

- | | | | | | |
|---|-----------|----|--------------|----|---------------|
| 1 | Tube assy | 6 | Back up ring | 11 | Nylon nut |
| 2 | Rod | 7 | Dust wiper | 12 | Stop ring |
| 3 | Gland | 8 | O-ring | 13 | Retainer ring |
| 4 | Bushing | 9 | Back up ring | | |
| 5 | Rod seal | 10 | Piston | | |

10. HYDRAULIC OIL TANK

1) STRUCTURE

- The oil from the hydraulic tank is sent from the pump through control valve to the cylinders. In the return circuit, the oil from various parts merges.
- A part of oil is cooled in the oil cooler (if equipped), passes through the hydraulic filter and returns to the hydraulic tank(1).
- If the hydraulic return oil filter becomes clogged, return filter bypass valve(9) acts to allow the oil to return directly to the hydraulic tank(1). This prevents damage to the hydraulic filter(8). The bypass valve(9) is also actuated when negative pressure is generated in the circuit.

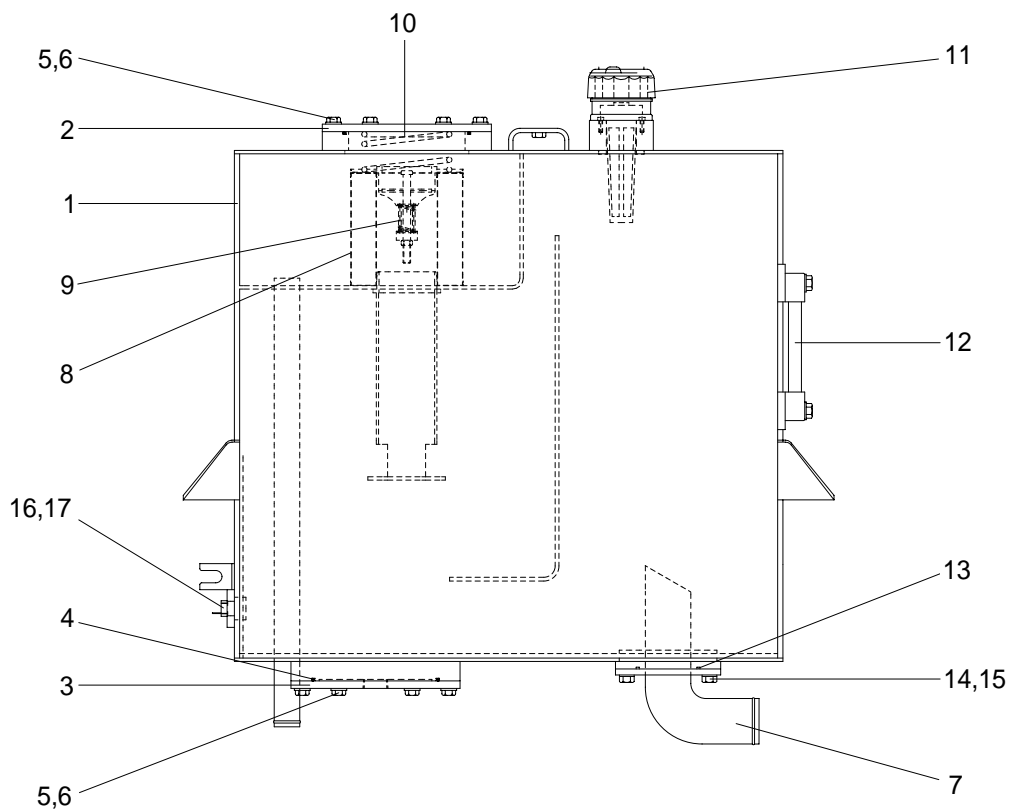

1	Hydraulic tank	7	Pipe	13	O-ring
2	Cover	8	Element	14	Bolt
3	Cover	9	Bypass valve	15	Hardened washer
4	O-ring	10	Spring	16	Overheat switch
5	Bolt	11	Air breather	17	O-ring
6	Hardened washer	12	Level gauge		

2) RETURN OIL FILTER BYPASS VALVE

(1) When the filter is clogged

Bypass valve(1) is opened and the oil returns directly to the tank without passing through the filter.

Bypass valve set pressure : 1.36kgf/cm²
(19.3psi)

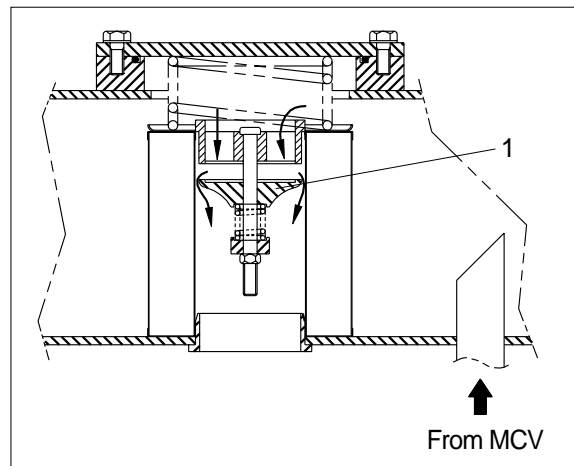

3) AIR BREATHER

The air breather is equipped with the capacity to perform three functions simultaneously-as an air filter, breathing valve, and as a lubrication opening.

(1) Preventing negative pressure inside the tank

The tank is a pressurized sealed type, so negative pressure is formed inside the hydraulic tank when the oil level drops during operations. When this happens, the difference in pressure between the tank and the outside atmospheric pressure opens the poppet in the breather, and air from the outside is let into the tank or prevent negative pressure.

(2) Preventing excessive pressure inside the tank

When the hydraulic cylinder is being used, the oil level in the hydraulic system increases and as temperature rises. If the hydraulic pressure rises above the set pressure, breather is actuated to release the hydraulic pressure inside the tank.

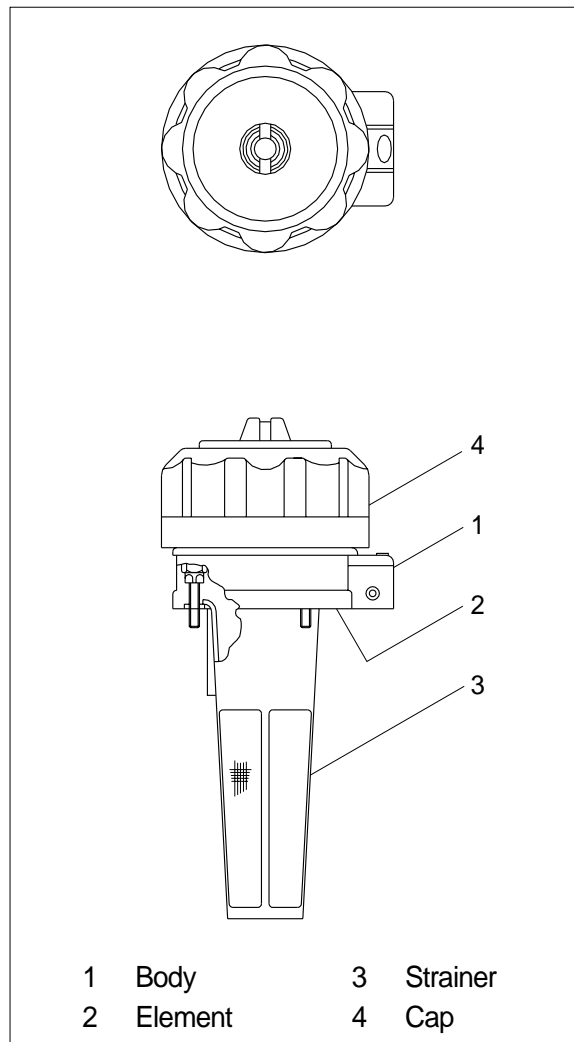

11. ACCUMULATOR

The accumulator is installed at the pilot oil supply unit. When the boom is left the raised position, and the control levers are operated with the engine stopped the pressure of the compressed nitrogen gas inside the accumulator sends pilot pressure to the control valve to actuate it and allow the boom and bucket to come down under their own weight.

Type of gas	Nitrogen gas(N ₂)
Volume of gas	0.75 l (0.2 U.S.gal)
Charging pressure of gas	16kgf/cm ² (228psi)
Max actuating pressure	30kgf/cm ² (427psi)

