

# SECTION 3 POWER TRAIN SYSTEM

## GROUP 1 STRUCTURE AND FUNCTION

### 1. POWER TRAIN COMPONENT OVERVIEW

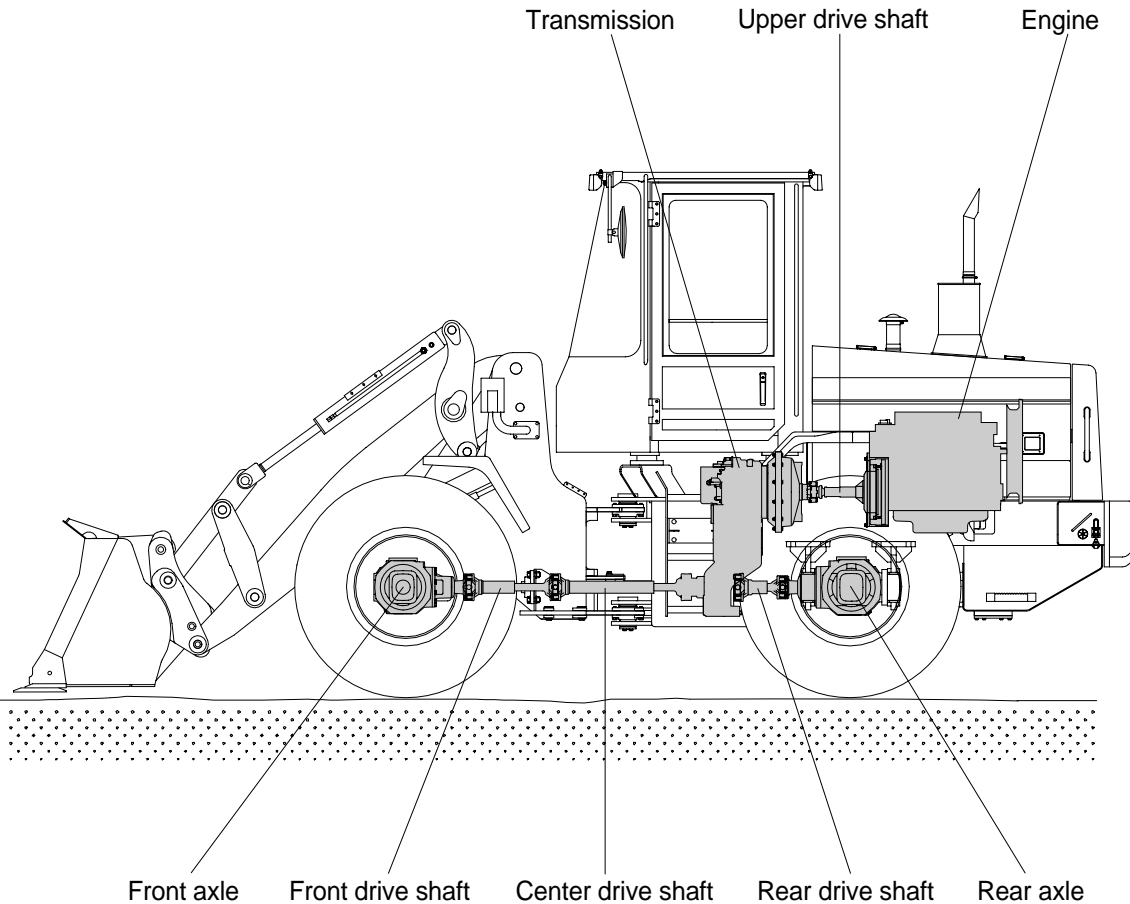

The power train consists of the following components :

- Transmission
- Front, center, rear and upper drive shafts
- Front and rear axles

Engine power is transmitted to the transmission through the torque converter.

The transmission is a hydraulically engaged four speed forward, three speed reverse countershaft type power shift transmission. A disk type parking brake is located in the front axle.

The transmission outputs through universal joints to three drive shaft assemblies. The front drive shaft is a telescoping shaft which drives the front axle. The front axle is mounted directly to the loader front frame. The front axle is equipped with limited slip differential.

The rear axle is mounted on an oscillating pivot. The rear axle is equipped with limited slip differential.

The power transmitted to front axle and rear axle is reduced by the pinion gear and ring gear of differential. It then passes from the differential to the sun gear shaft(Axle shaft) of final drive.

The power of the sun gear is reduced by a planetary mechanism and is transmitted through the planetary hub to the wheel.

# HYDRAULIC CIRCUIT

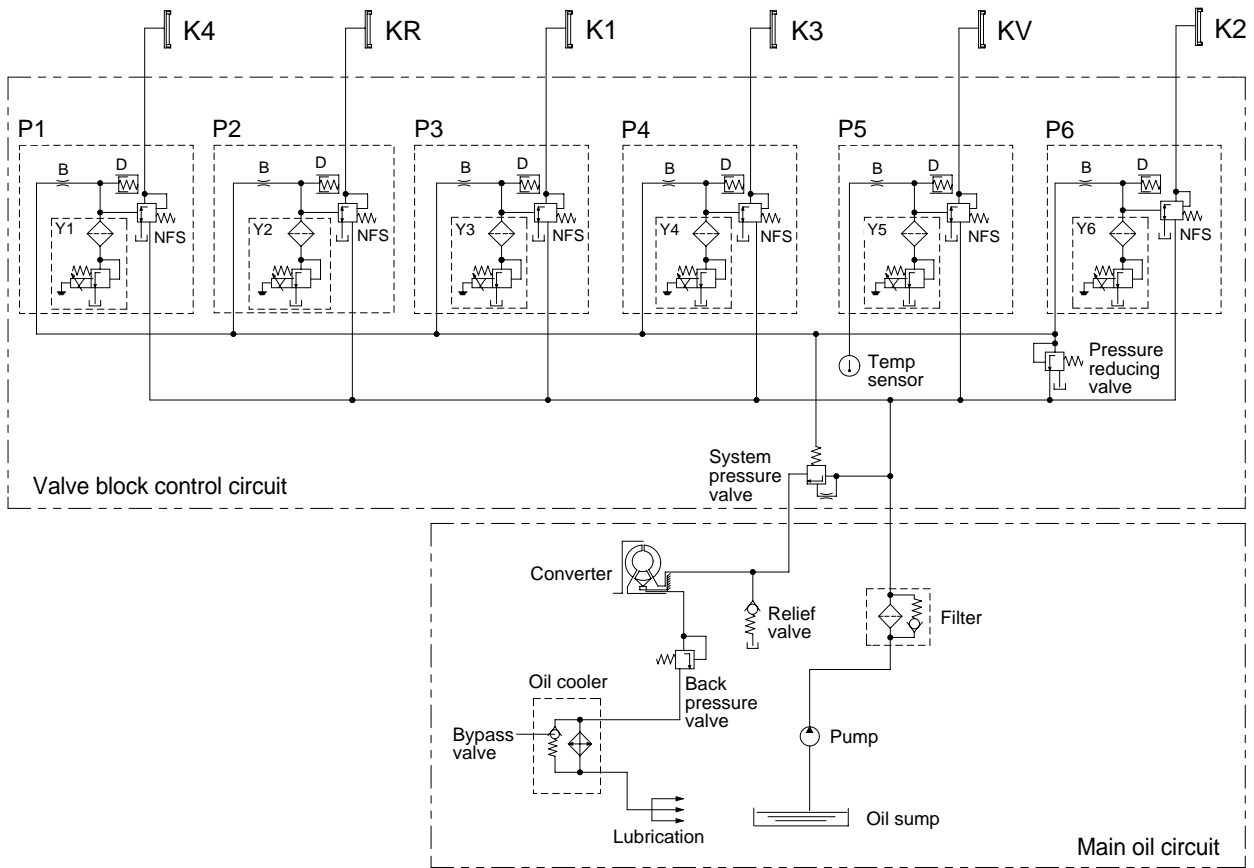

- |     |                              |       |                              |
|-----|------------------------------|-------|------------------------------|
| NFS | Follow-on slide              | P3    | Proportional valve clutch K1 |
| D   | Oscillation damper           | P4    | Proportional valve clutch K3 |
| B   | Orifice                      | P5    | Proportional valve clutch KV |
| P1  | Proportional valve clutch K4 | P6    | Proportional valve clutch K2 |
| P2  | Proportional valve clutch KR | Y1~Y6 | Pressure regulator           |

Speed	Forward				Reverse			Neutral
	1	2	3	4	1	2	3	
Y1				X				
Y2					X	X	X	
Y3	X				X			
Y4			X	X			X	
Y5	X	X	X					
Y6		X				X		

X : Pressure regulator under voltage

## 2. TORQUE CONVERTER

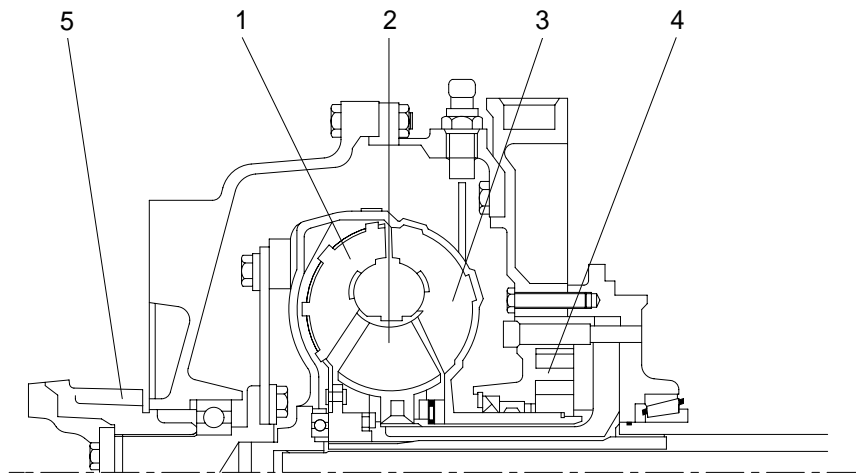

- |   |        |   |                   |   |              |
|---|--------|---|-------------------|---|--------------|
| 1 | Pump   | 3 | Turbine           | 5 | Input flange |
| 2 | Stator | 4 | Transmission pump |   |              |

The converter is working according to the Trilok-system, i.e. it assumes at high turbine speed the characteristics, and with it the favorable efficiency of a fluid clutch.

The converter will be defined according to the engine power so that the most favorable operating conditions for each installation case are given.

**The Torque converter is composed of 3 main components :**  
**Pump wheel - turbine wheel - stator(Reaction member)**

These 3 impeller wheels are arranged in such a ring-shape system that the fluid is streaming through the circuit components in the indicated order.

Pressure oil is constantly streaming out of the transmission pump through the converter. In this way, the converter can fulfill its task to multiply the torque of the engine, and at the same time, the heat created in the converter is dissipated through the escaping oil.

The oil, escaping out of the pump wheel, enters the turbine wheel and is there inverted in the direction of flow.

According to the rate of inversion, the turbine wheel and with it also the output shaft, receive a more or less high reaction moment. The stator(Reaction member), following the turbine, has the task to inverse again the oil which is escaping out of the turbine and to delivery it under the suitable discharge direction to the pump wheel.

Due to the inversion, the stator receives a reaction moment.

The relation turbine moment/pump moment is called torque conversion. This is the higher the greater the speed difference of pump wheel and turbine wheel will be.

Therefore, the maximum conversion is created at standing turbine wheel.

With increasing output speed, the torque conversion is decreasing. The adaption of the output speed to a certain required output moment is infinitely variable and automatically achieved by the torque converter.

If the turbine speed is reaching about 80% of the pump speed, the conversion becomes 1.0 i.e. the turbine moment becomes equal to that of the pump moment.

From this point on, the converter is working similar to a fluid clutch.

A stator freewheel serves to improve the efficiency in the upper driving range, it is backing up in the conversion range the moment upon the housing, and is released in the coupling range.

In this way, the stator can rotate freely.

**Function of a hydrodynamic torque converter(Schematic view)**

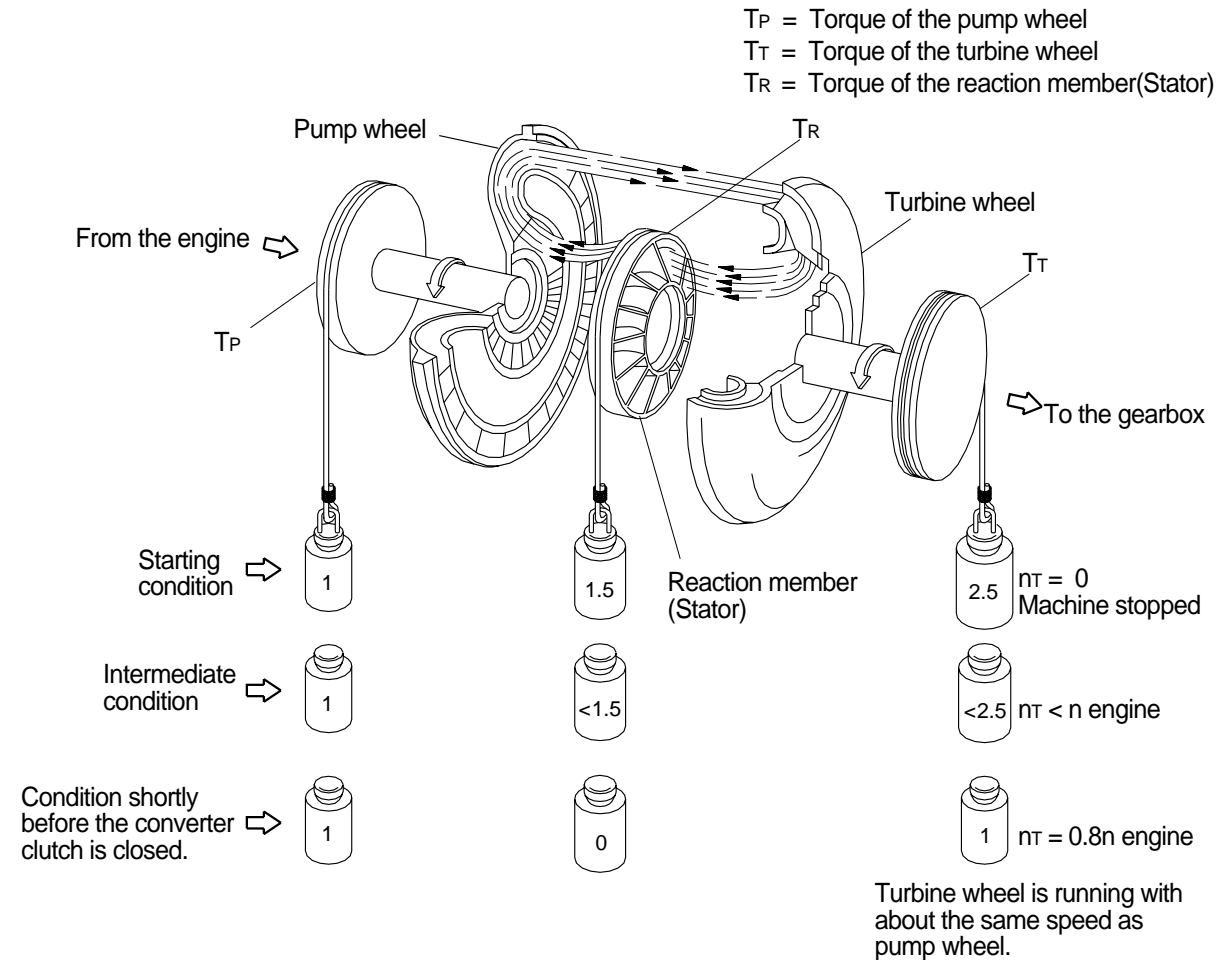

### 3. TRANSMISSION

#### 1) LAYOUT

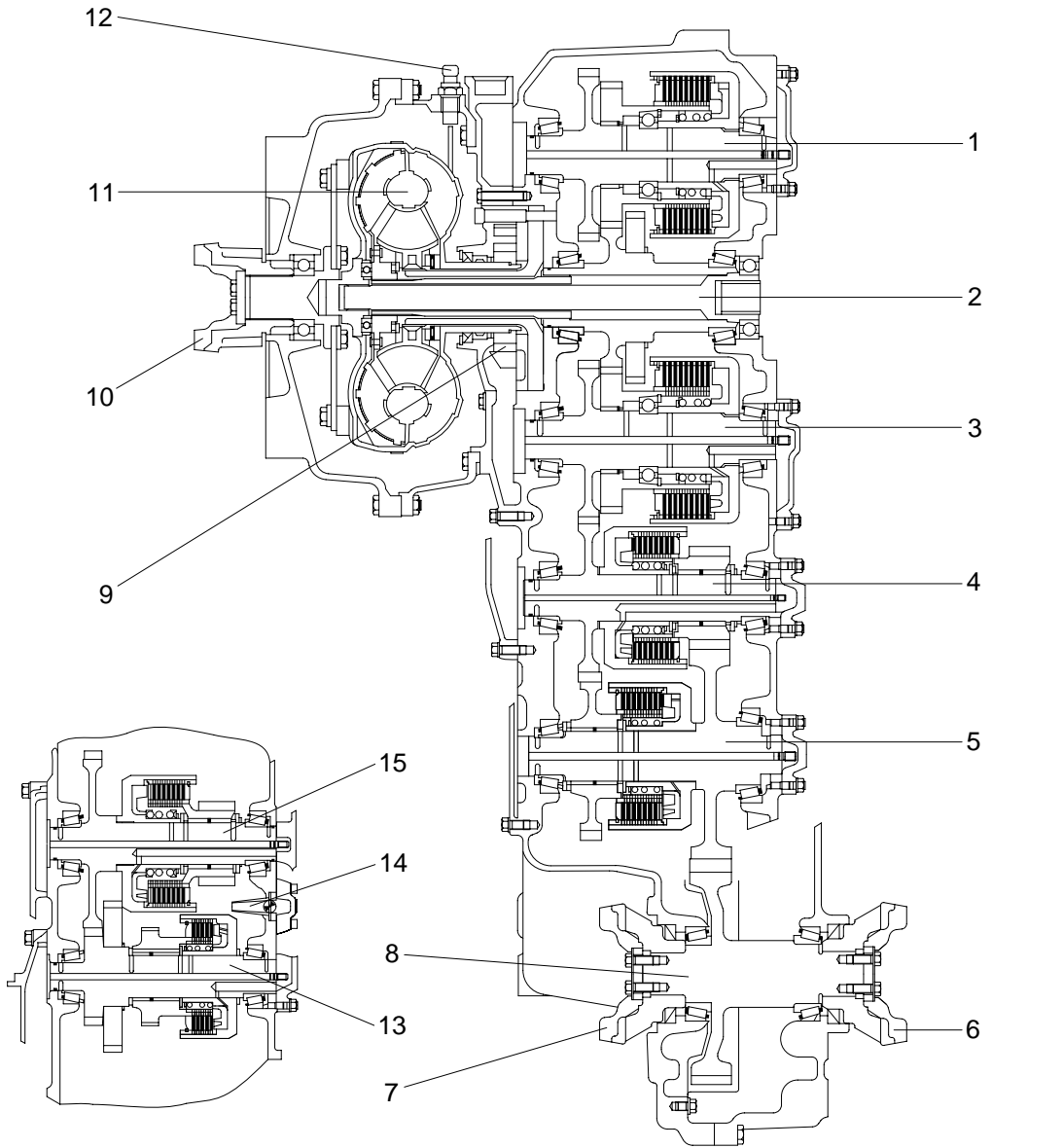

- 1 Reverse clutch(KR)
- 2 Engine-dependent power take-off
- 3 Forward clutch(KV)
- 4 2nd clutch(K2)
- 5 3rd clutch(K3)

- 6 Rear output flange
- 7 Converter side output flange
- 8 Output shaft
- 9 Transmission pump
- 10 Input flange

- 11 Converter
- 12 Inductive transmitter for engine speed
- 13 4th clutch(K4)
- 14 Converter relief valve
- 15 1st clutch(K1)

## 2) INSTALLATION VIEW

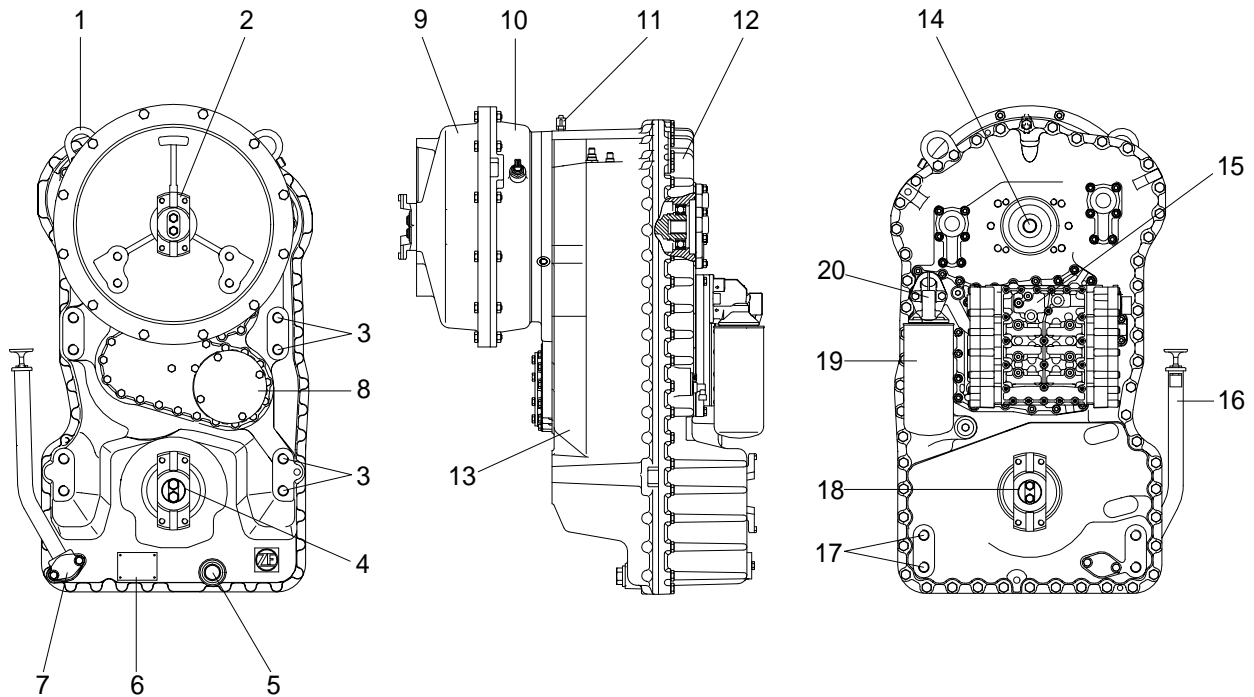

- |    |  |    |  |
|----|--|----|--|
| 1  | Lifting lugs   | 11 | Breather   |
| 2  | Input flange-input through universal shaft                                     | 12 | Transmission-case cover                                      |
| 3  | Transmission suspension threads M20  | 13 | Transmission case  |
| 4  | Output flange-converter side   | 14 | Power take-off; Coaxial;<br>Engine-dependent                 |
| 5  | Oil drain plug with magnetic insert M38 × 1.5                                  | 15 | Electro-hydraulic control                                    |
| 6  | Model identification plate   | 16 | Oil level tube with oil dipstick                             |
| 7  | Attachment possibility for oil level tube<br>with oil dipstick(Converter side) | 17 | Transmission suspension threads M20                          |
| 8  | Attachment possibility for emergency<br>steering pump                          | 18 | Output flange-rear   |
| 9  | Cover  | 19 | Exchange filter(Fine filter)                                 |
| 10 | Converter bell housing   | 20 | Filter head with connection for filter<br>restriction switch |

### 3) OPERATION OF TRANSMISSION

#### (1) Forward

##### ① Forward 1st

In 1st forward, forward clutch and 1st clutch are engaged.

Forward clutch and 1st clutch are actuated by the hydraulic pressure applied to the clutch piston.

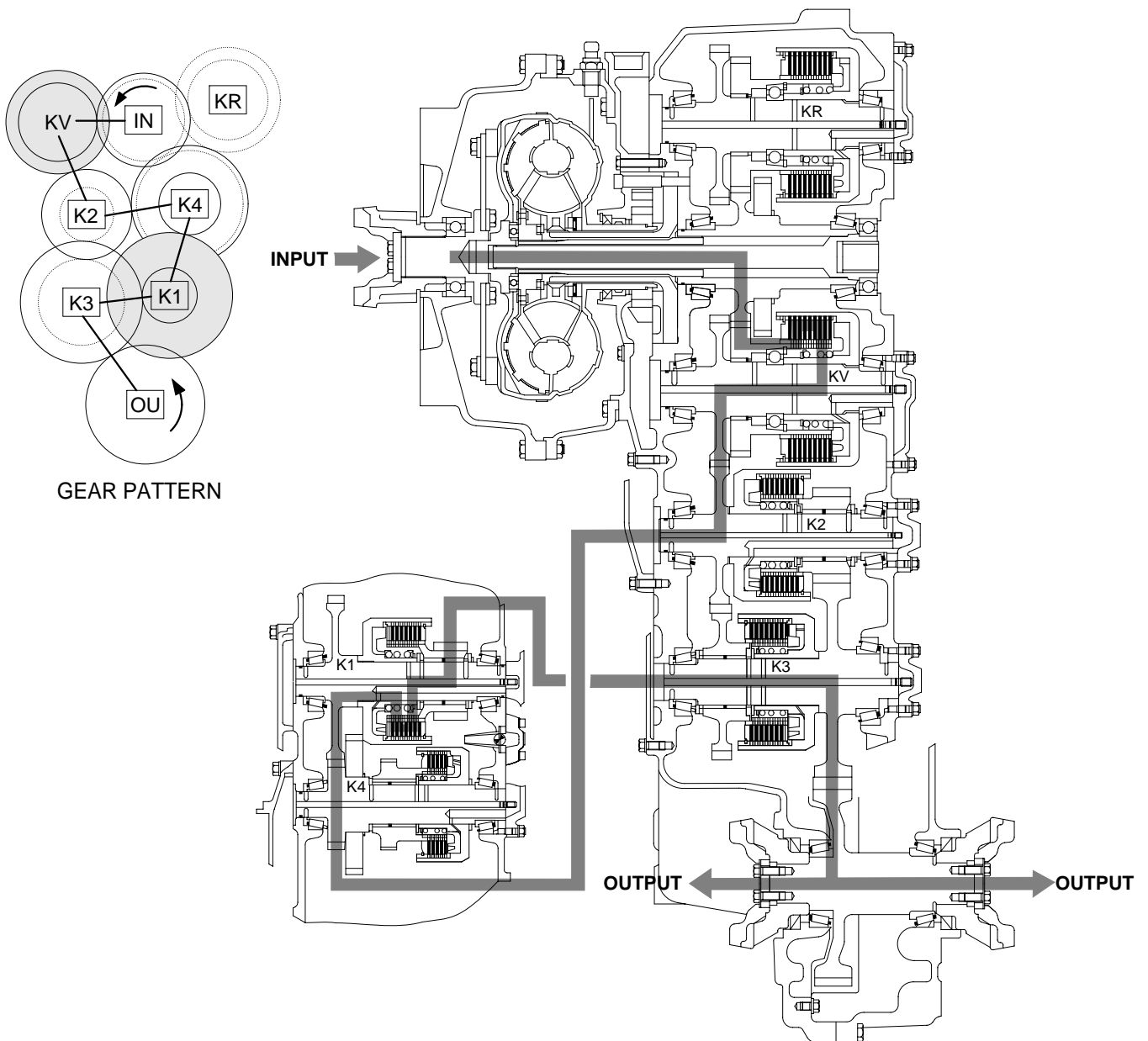

## ② Forward 2nd

In 2nd forward, forward clutch and 2nd clutch are engaged.

Forward clutch and 2nd clutch are actuated by the hydraulic pressure applied to the clutch piston.

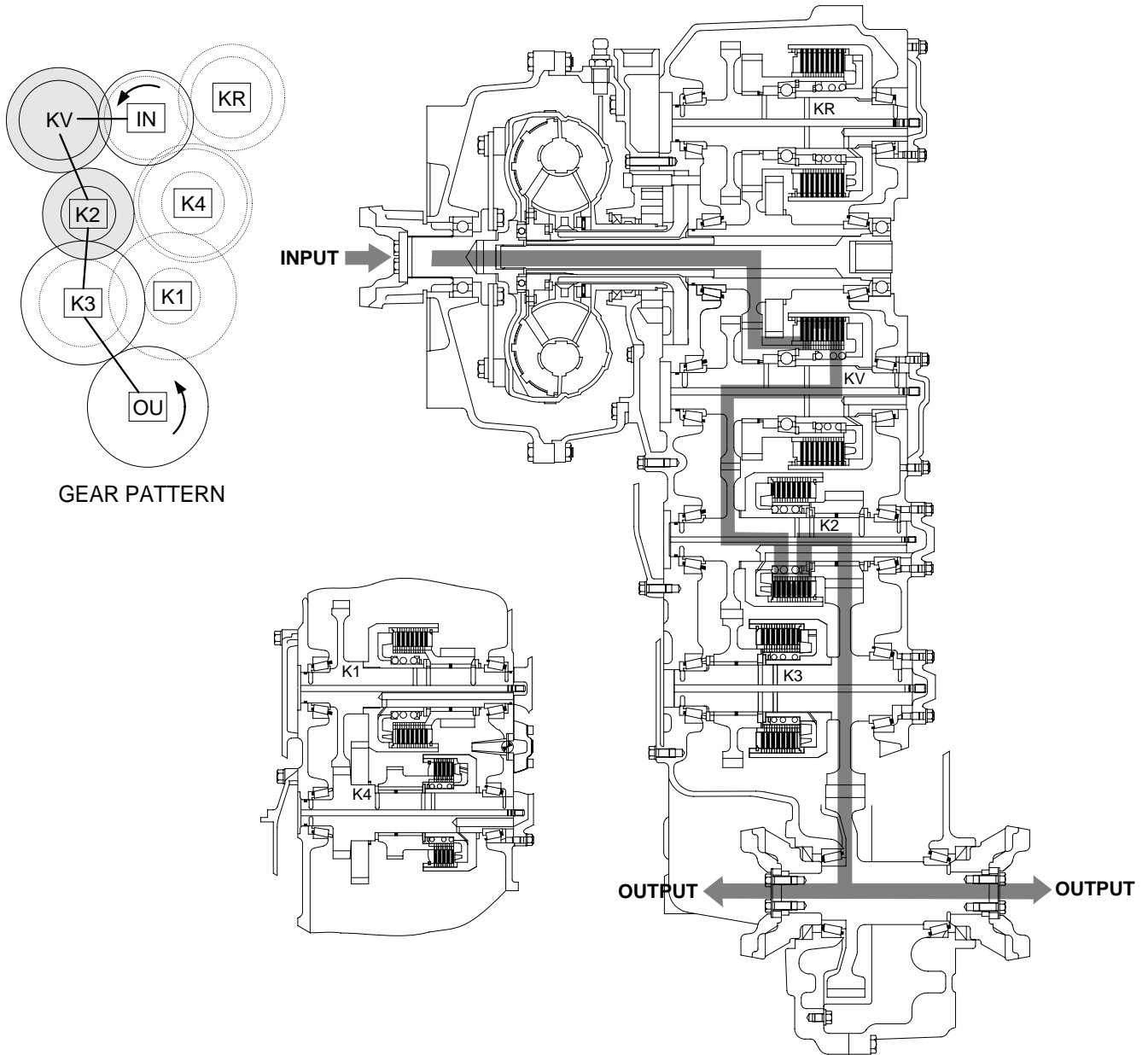



### ③ Forward 3rd

In 3rd forward, forward clutch and 3rd clutch are engaged.

Forward clutch and 3rd clutch are actuated by the hydraulic pressure applied to the clutch piston.

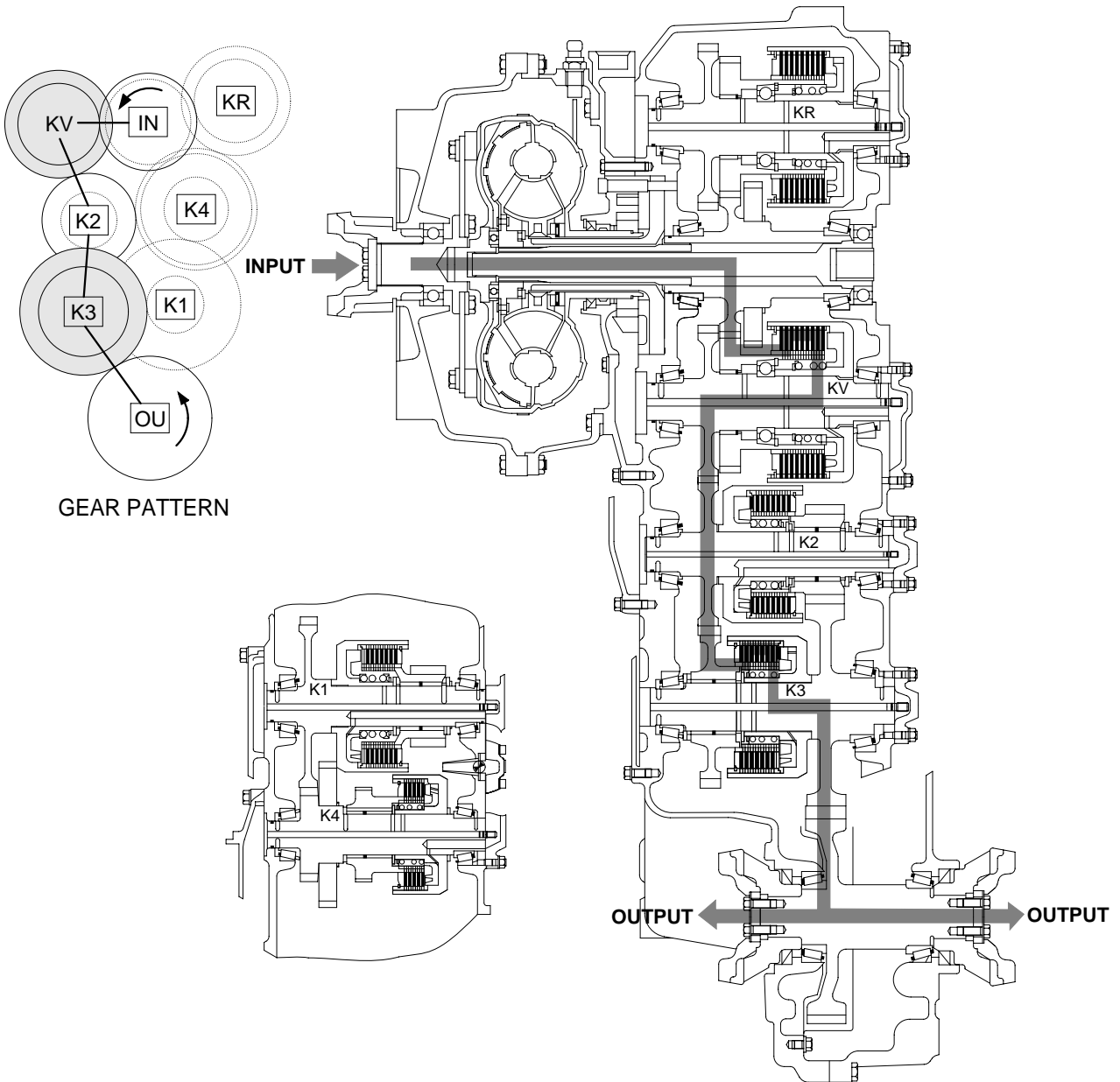

#### ④ Forward 4th

In 4th forward, 4th clutch and 3rd clutch are engaged.

4th clutch and 3rd clutch are actuated by the hydraulic pressure applied to the clutch piston.

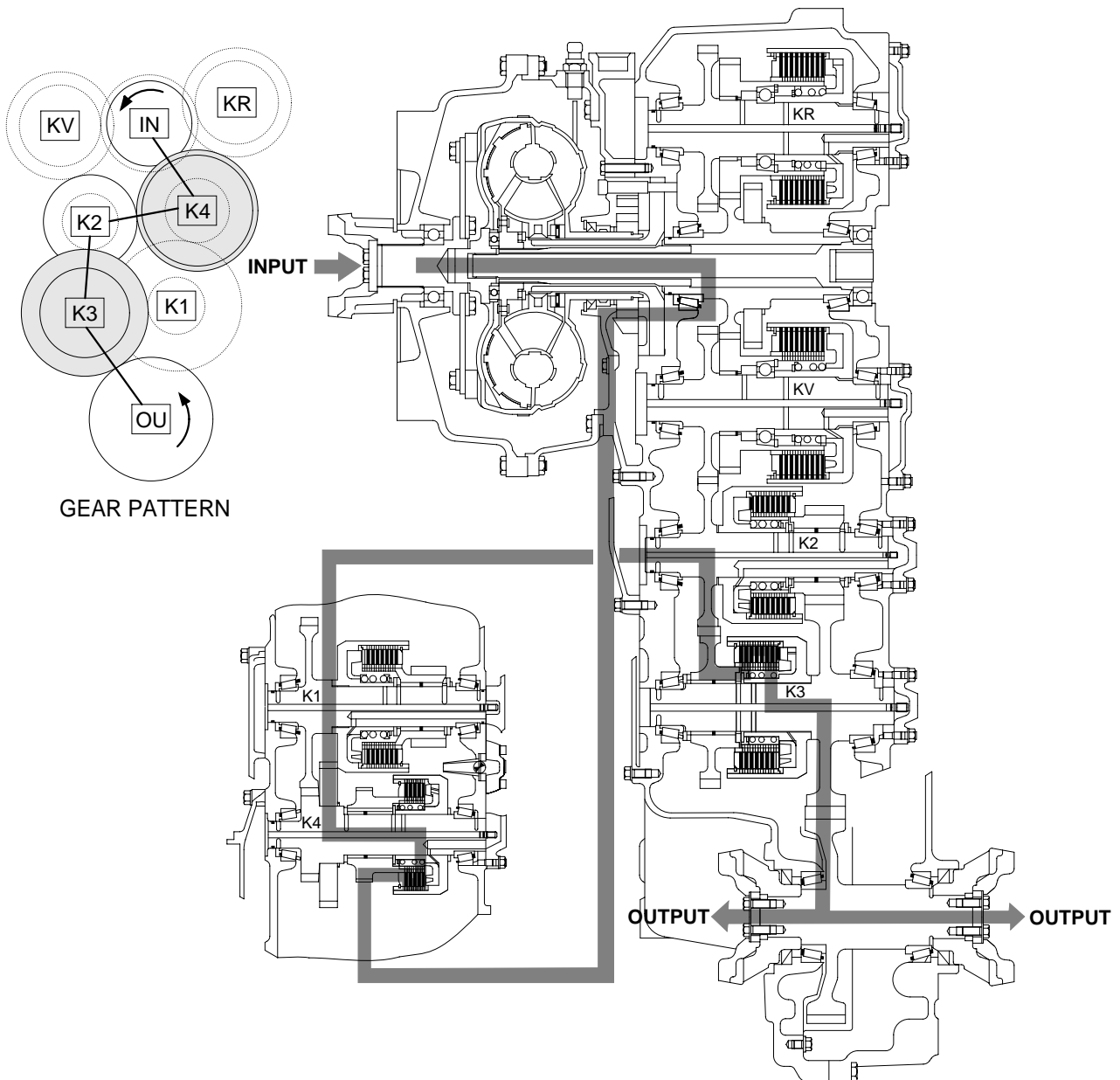

## (2) Reverse

### ① Reverse 1st

In 1st reverse, reverse clutch and 1st clutch are engaged.

Reverse clutch and 1st clutch are actuated by the hydraulic pressure applied to the clutch piston.

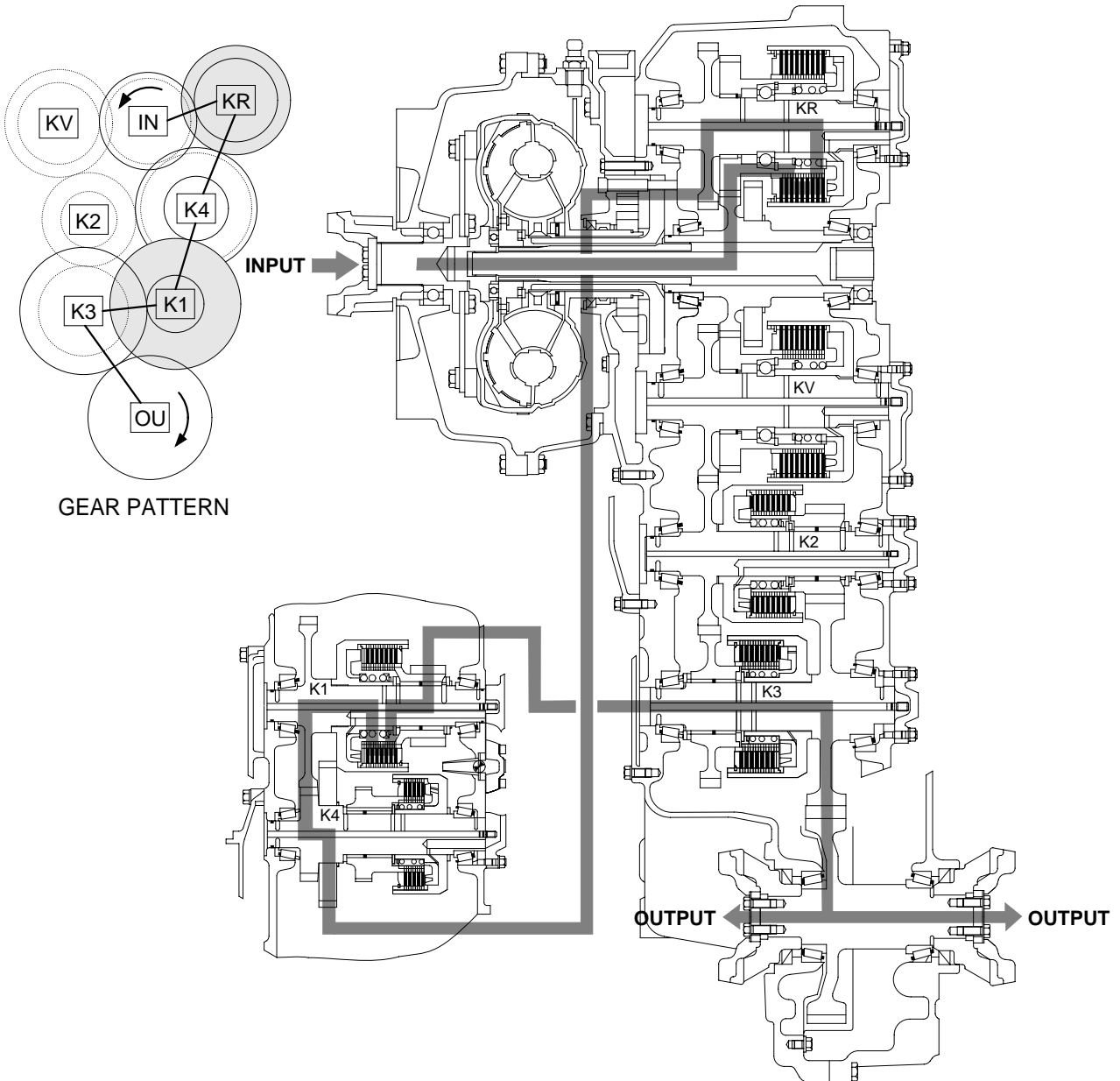

## ② Reverse 2nd

In 2nd reverse, reverse clutch and 2nd clutch are engaged.

Reverse clutch and 2nd clutch are actuated by the hydraulic pressure applied to the clutch piston.

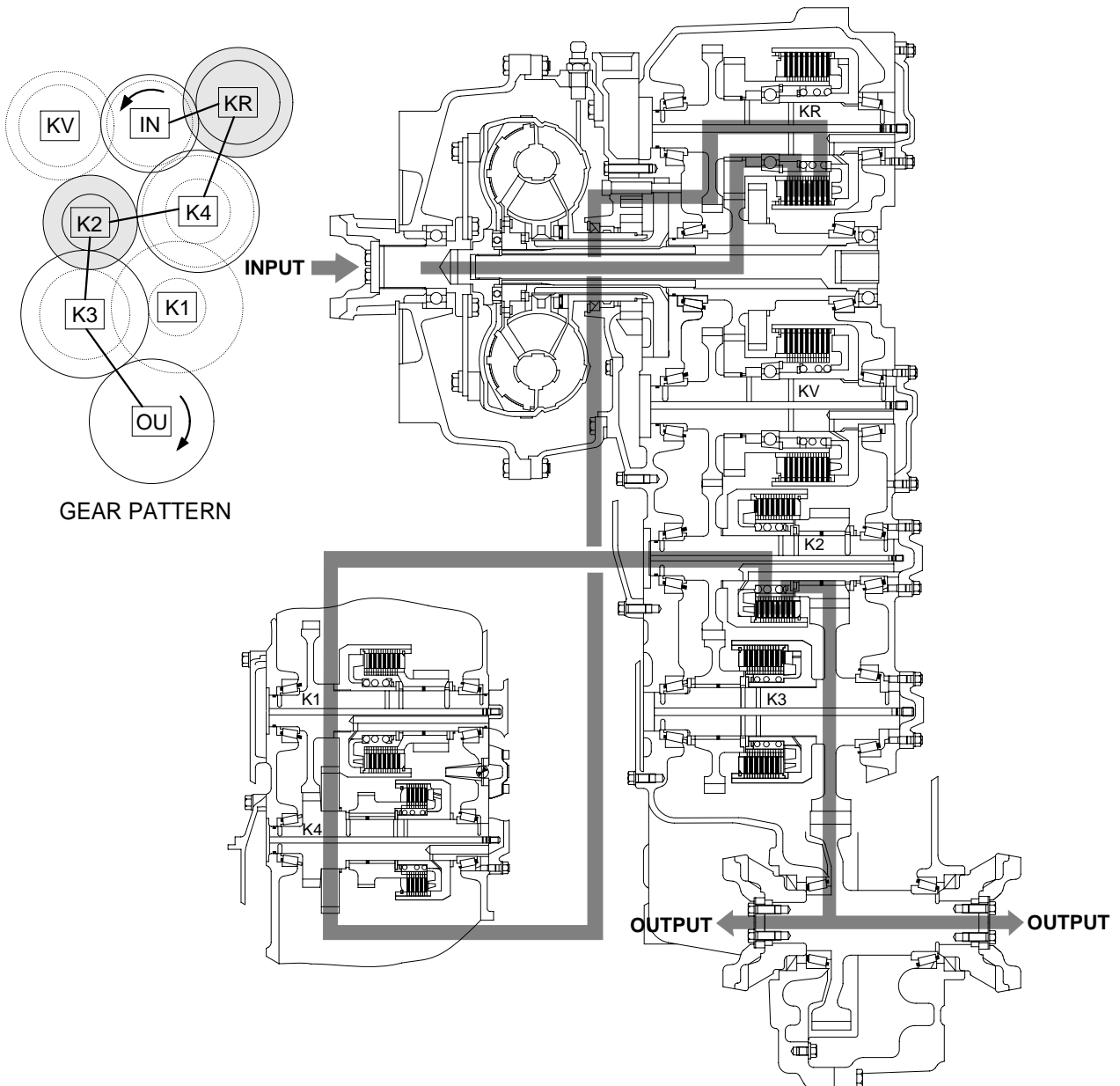

### ③ Reverse 3rd

In 3rd reverse, reverse clutch and 3rd clutch are engaged.

Reverse clutch and 3rd clutch are actuated by the hydraulic pressure applied to the clutch piston.

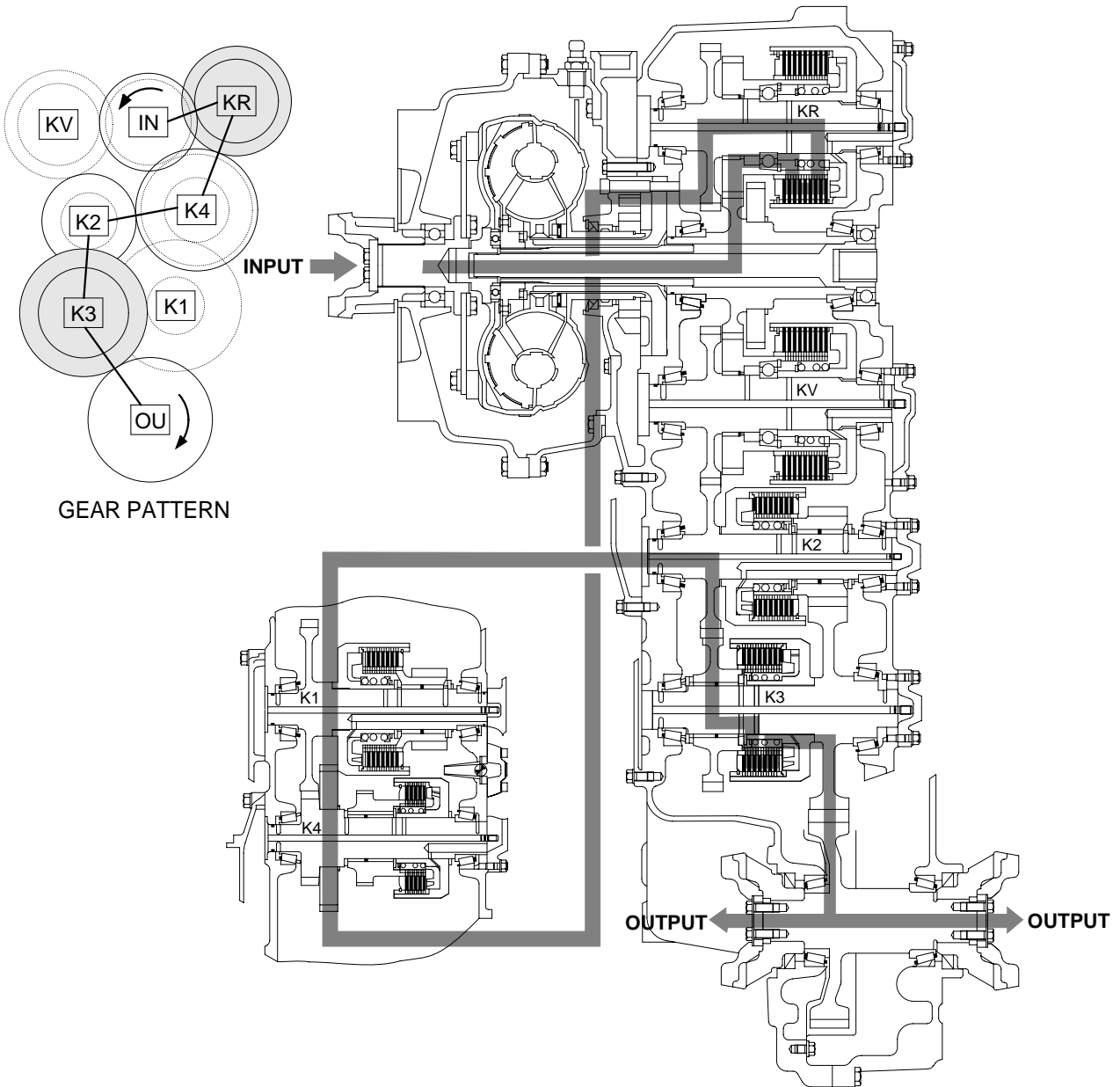

#### 4) ELECTRO-HYDRAULIC SHIFT CONTROL WITH PROPORTIONAL VALVE

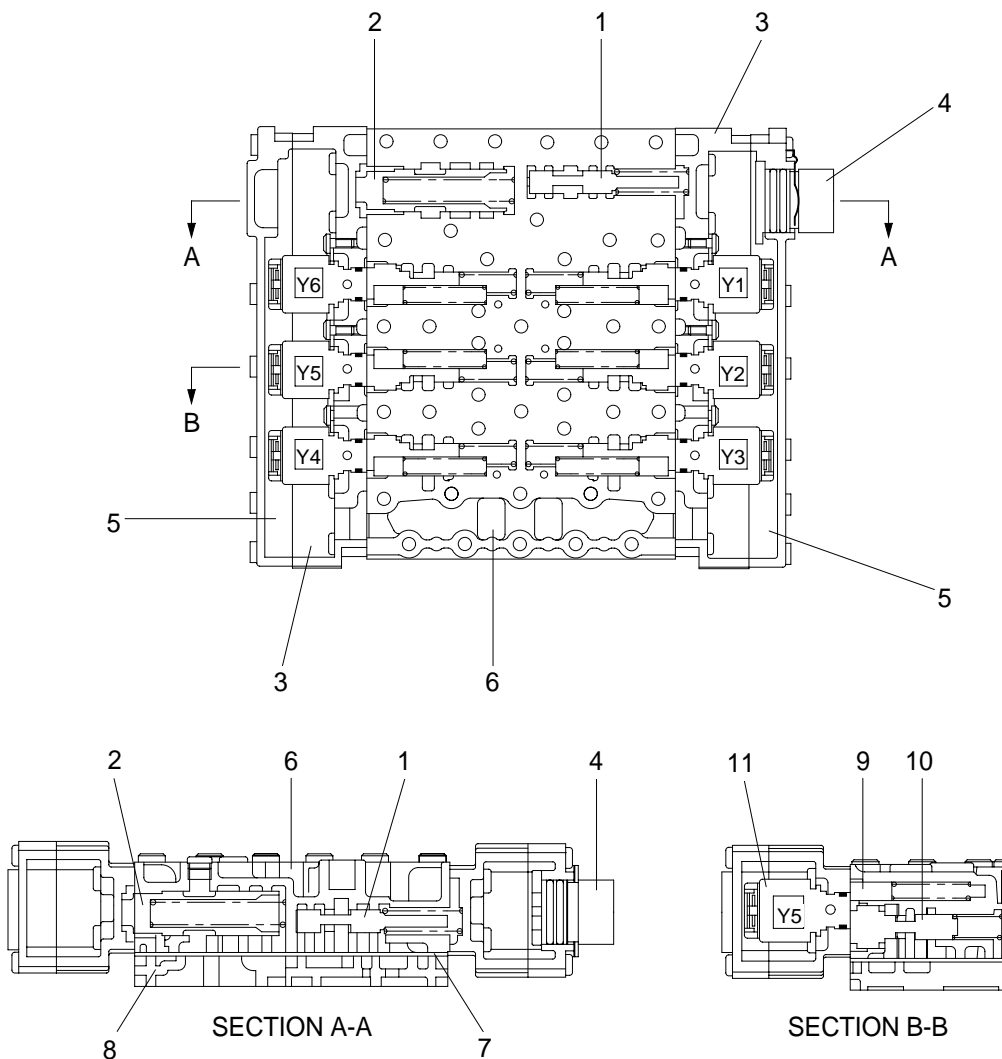

- |   |                                 |    |                    |
|---|---------------------------------|----|--------------------|
| 1 | Pressure reducing valve(9 bar)  | 7  | Intermediate sheet |
| 2 | System pressure valve(16+2 bar) | 8  | Duct plate         |
| 3 | Housing                         | 9  | Oscillation damper |
| 4 | Cable harness                   | 10 | Follow-on slide    |
| 5 | Cover                           | 11 | Pressure regulator |
| 6 | Valve block                     |    |                    |

Transmission control see schedule of measuring points, hydraulic schematic and electro-hydraulic control unit at page 3-2, 3-14 and 3-44.

The six clutches of the transmission are selected through the 6 proportional valves P1 to P6. The proportional valve(Pressure regulator-unit) consists of pressure regulator(e.g. Y1), booster valve oscillation damper.

The pilot pressure of 9 bar for the control of the follow-on slides is created by the reducing valve. The pressure oil (16+2 bar) is directed through the follow-on slide to the corresponding clutch.

By the direct proportional selection with separate pressure modulation for each clutch, the pressures to the clutches, taking part in the gear change, are controlled. In this way, a hydraulic overlap of the clutches to be engaged and disengaged is achieved.

This is leading to fast shiftings without traction force interruption.

At the shifting, the following criteria are considered:

- Speed of engine, turbine, central gear train and output.
- Transmission temperature.
- Shifting mode(Up-, down-, reverse shifting and gear engaging from neutral).
- Load level(Full- and partial load, traction, coasting inclusive consideration of load cycles during the shifting).

The system pressure valve is limiting the maximum control pressure to 16+2 bar and releases the main stream to the converter and lubricating circuit.

A converter relief valve is installed in the converter inlet, which protects the converter against high internal pressures(Opening pressure 9bar).

Within the converter, the oil transfers the power transmission according to the well-known hydrodynamic principle(See torque converter, page 3-3).

In order to avoid cavitation, the converter must be always completely filled with oil.

This is achieved by a converter back pressure valve, following the converter, with an opening pressure of about 3.5bar.

The oil, escaping from the converter, is directed to a oil cooler.

The oil is directed from the oil cooler to the transmission and from there to the lubricating-oil circuit so that all lubricating points are supplied with cooled oil.

In the electro-hydraulic control unit there are 6 pressure regulators installed.

## 5) GEAR SELECTOR(DW-3)

The gear selector is designed for the mounting on the left side of the steering column. The positions(Speeds) 1 to 4 are selected by a rotary motion, the driving direction Forward(F)-Neutral(N)-Reverse(R) by tilting the gear selector lever.

The gear selector is also available with integrated kickdown control knob.

A neutral lock is installed as protection against inadvertent drive off.

Position **N** - Gear selector lever blocked in this position.

Position **D** - Driving.

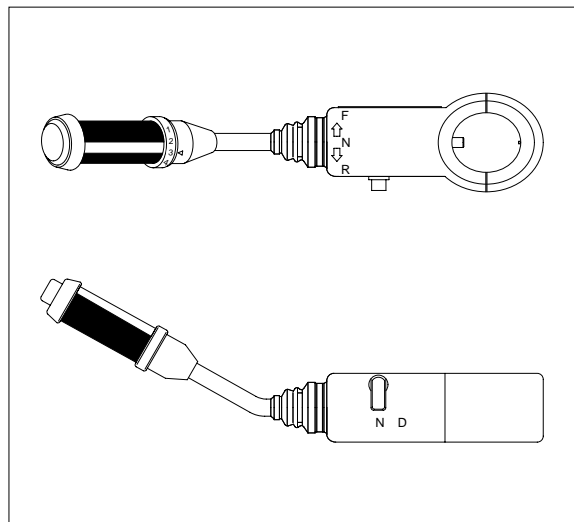



## 6) DISPLAY

### (1) Function

The display can be used with the gear selector(DW-3). It indicates speed and driving direction as well as the activated kickdown.

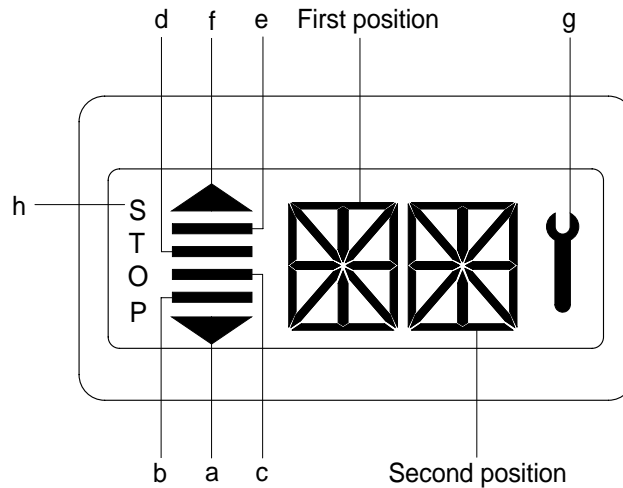
When driving in the automatic mode, a bar indicator gives additionally also information about the selected driving range; The automatic range is symbolized by arrows above and below the bar indicator. In case of possible errors in the system, a wrench appears on the display, combined with indication of the error number. Also sporadically occurring errors can be indicated.



1	Bars	a	Preselection reverse driving direction
		b, c, d, e	Monitoring different gear-ranges
		f	Preselection forward driving direction
		Flashing	Kick-down modus is activated
2	First position		Shows the actual driving direction F : Forward, R : Reverse
			First segment of the error code
3	Second position		Shows the current gear
			Second segment of the error code
4	Spanner	g	Electronic control unit recognized an error
5	Letters <b>STOP</b>	h	Immediate stop is required(At the moment not activated)



## (2) Definition of the error codes

### Introduction

The error codes consists of two hexadecimal numbers.

The first number shows the type of signal, the second number shows signal and the type of the error.

### Description of error codes

First No.	Meaning of number
1 hex	Digital input signals
2 hex	Analog input signals
3 hex	Speed signals
4 hex	Speed signals
7 hex	Analog current output signals
8 hex	Analog current output signals
9 hex	Digital output signals
A hex	Digital output signals
B hex	Clutch errors
D hex	Power supply
E hex	High speed signals
F hex	General errors

### List of error codes

Number	Meaning of error code	
11 hex	Logical error at gear range signal	
12 hex	Logical error at direction select signal	
21 hex	Short circuit to battery voltage at clutch cutoff input	
22 hex	Short circuit to ground or open circuit at clutch cutoff input	
23 hex	Short circuit to battery voltage at load sensor input	not used
24 hex	Short circuit to ground or open circuit at load sensor input	not used
25 hex	Short circuit to battery voltage or open circuit at temperature sensor input	
26 hex	Short circuit to ground at temperature sensor input	
31 hex	Short circuit to battery voltage at engine speed input	
32 hex	Short circuit to ground or open circuit at engine speed input	
33 hex	Logical error at engine speed input	
34 hex	Short circuit to battery voltage at turbine speed input	
35 hex	Short circuit to ground or open circuit at turbine speed input	
36 hex	Logical error at turbine speed input	
37 hex	Short circuit to battery voltage at internal speed input	
38 hex	Short circuit to ground or open circuit at internal speed input	
39 hex	Logical error at internal speed input	

Number	Meaning of error code	
3A hex	Short circuit to battery voltage at output speed input	
3B hex	Short circuit to ground or open circuit at output speed input	
3C hex	Logical error at output speed input	
71 hex	Short circuit to battery voltage at clutch K1	
72 hex	Short circuit to ground at clutch K1	
73 hex	Open circuit at clutch K1	
74 hex	Short circuit to battery voltage at clutch K2	
75 hex	Short circuit to ground at clutch K2	
76 hex	Open circuit at clutch K2	
77 hex	Short circuit to battery voltage at clutch K3	
78 hex	Short circuit to ground at clutch K3	
79 hex	Open circuit at clutch K3	
7A hex	Short circuit to battery voltage at converter clutch	not used
7B hex	Short circuit to ground at converter clutch	not used
7C hex	Open circuit at converter clutch	not used
81 hex	Short circuit to battery voltage at clutch K4	
82 hex	Short circuit to ground at clutch K4	
83 hex	Open circuit at clutch K4	
84 hex	Short circuit to battery voltage at clutch KV	
85 hex	Short circuit to ground at clutch KV	
86 hex	Open circuit at clutch KV	
87 hex	Short circuit to battery voltage at clutch KR	
88 hex	Short circuit to ground at clutch KR	
89 hex	Open circuit at clutch KR	
91 hex	Short circuit battery voltage at relay reverse warning alarm	
92 hex	Short circuit to ground at relay reverse warning alarm	
93 hex	Open circuit at relay reverse warning alarm	
94 hex	Short circuit to battery voltage at relay starter interlock	
95 hex	Short circuit to ground at relay starter interlock	
96 hex	Open circuit at relay starter interlock	
97 hex	Short circuit to battery voltage at park brake solenoid	
98 hex	Short circuit ground at park brake solenoid	
99 hex	Open circuit at park brake solenoid	

Number	Meaning of error code	
B1 hex	Slippage at clutch K1	
B2 hex	Slippage at clutch K2	
B3 hex	Slippage at clutch K3	
B4 hex	Slippage at clutch K4	
B5 hex	Slippage at clutch KV	
B6 hex	Slippage at clutch KR	
D1 hex	Short circuit to battery voltage at power supply for sensors	
D2 hex	Short circuit to ground at power supply for sensors	
D3 hex	Low power at battery	
D4 hex	High power at battery	
D5 hex	Error at switch 1 for valve power supply	
D6 hex	Error at switch 2 for valve power supply	
E1 hex	Short circuit to battery voltage at speedometer output	not used
E2 hex	Short circuit to ground or open circuit at speedometer output	not used
E3 hex	Short circuit to battery voltage at display output	not used
E4 hex	Short circuit to ground or open circuit at display output	not used
E5 hex	Error at communication on CAN	
F1 hex	General EEPROM fault	
F2 hex	Configuration lost	
F3 hex	Application error	

### Summary

This is only a proposal for error codes. If necessary, we will change the error codes or we will add new error codes.

## 7) ELECTRIC CONTROL UNIT

### (1) Complete system

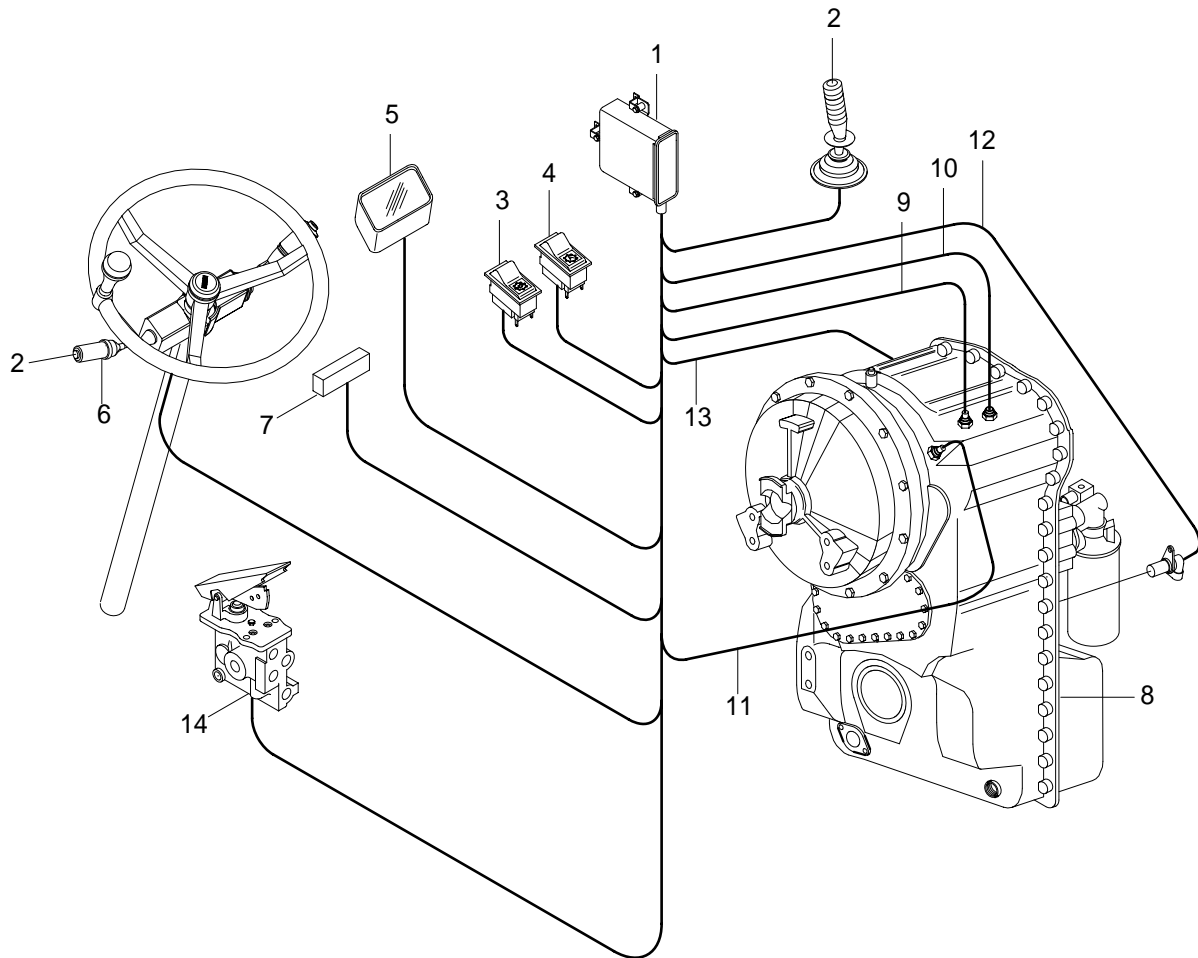

- 1 Control unit(EST-37)
- 2 Kickdown switch
- 3 Clutch cut off switch
- 4 Full automatic switch
- 5 Display
- 6 Gear selector(DW-3) with integrated kickdown switch
- 7 Supply-system connection
- 8 Transmission
- 9 Cable to inductive transmitter - speed central gear train
- 10 Cable to inductive transmitter - speed turbine
- 11 Cable to inductive transmitter - speed engine
- 12 Cable to speed sensor output and speedometer
- 13 Cable to plug connection on the electro - hydraulic control unit
- 14 Brake pressure sensor/load sensor

### (2) Description of the basic functions

The powershift-reversing transmissions will be equipped with the electronic transmission control unit(EST-37), developed for them.

The system is processing the wishes of the driver according to the following criteria.

- Speed definition as a function of gear selector position, driving speed and load level.

- Protection against operating errors, as far as possible and practical.
- Protection against overspeeds(On the basis of engine and turbine speed).
- Reversing-automatic system(Driving speed-dependent).
- Pressure cut off(Disconnecting of the drive train for maximum power on the power take-off).
- Switch for manual or automatic operation.
- Reversing function button, respectively kickdown function.

### (3) Gearshifts

The control unit(EST-37) shifts the required speeds fully-automatically under consideration of the following criteria.

- Gear selector position
- Driving speed
- Load level

At the same time, the following speeds are picked up by the control unit(EST-37).

- n Engine
- n Turbine
- n Central gear train
- n Output

#### - Neutral position

Neutral position is selected through the gear selector.

After the ignition is turned on, the electronics remains in the waiting state; By the position **neutral** of the gear selector, respectively by pressing on the key **neutral**, the control unit(EST-37) becomes ready for operation.

Now, a speed can be engaged.

#### - Speed engagement

In principle, the speed, adapted to the driving speed(At standing, or rolling machine), will be engaged. The engagement is realized in dependence on load and rotational speed.

#### - Upshifting under load

Upshifting under load will be then realized if the machine can still accelerate by it.

#### - Downshifting under load

Downshifting under load will be realized if more traction force is needed.

#### - Upshifting in coasting condition

In the coasting condition, the upshifting will be suppressed if the speed of the machine on a slope shall not be further increased.

#### - Downshifting in coasting condition

Downshiftings in the coasting condition will be realized if the machine shall be retarded.

#### - Reversing

At speeds below the reversing limit, direct reversing can be carried out at any time in the speeds  $1F \Leftrightarrow 1R$  and  $2F \Leftrightarrow 2R$ (As a rule, this is the maximum driving speed of the 2nd speed).

**Reversings in the speeds 3 and 4 are realized dependent on the driving speed.**

- Above the programmed reversing limit, the machine is braked down by downshifts of the electronic control unit(EST-37) to the permitted driving speed, and only then, the reversing into the correspondingly preselected speed will be carried out.
- Below the permitted driving speed, the reversing is carried out immediately.

**(4) Specific kickdown function**

By means of the kickdown-button, integrated in the gear selector, it is at any time possible to select in the speeds 2F and 2R(i.e. position 2 of the gear selector, at automatic mode also in the 2nd speed of the automatic range) the 1st speed by a short touch. This kickdown state can be cancelled by :

1. Pressing the kickdown-button again
2. Realization of a reversal operation
3. Change of the gear selector position by the following modification  
Gear selector(DW-3) - (Rotation) of the driving position 1...4.

The kickdown function will be always terminated by shifting to neutral.

**(5) Clutch cut off**

Especially at wheel loaders, the clutch cut off can be activated through a switch signal. It is interrupting the power flow in the transmission as long as this signal is active. Besides, this function can be used for the transmission-neutral shifting at applied hand brake or as **emergency-stop**(In this case, a restarting is only possible through the gear selector-neutral position).

## 5. AXLE

### 1) OPERATION

- The power from the engine passes through torque converter, transmission and drive shafts, and is then sent to the front and rear axles.
- Inside the axles, the power passes from the bevel pinion to the bevel gear and is sent at right angles. At the same time, the speed is reduced and passes through the both differentials to the axle shafts. The power of the axle shafts is further reduced by planetary-gear-type final drives and is sent to the wheels.

#### (1) Front axle

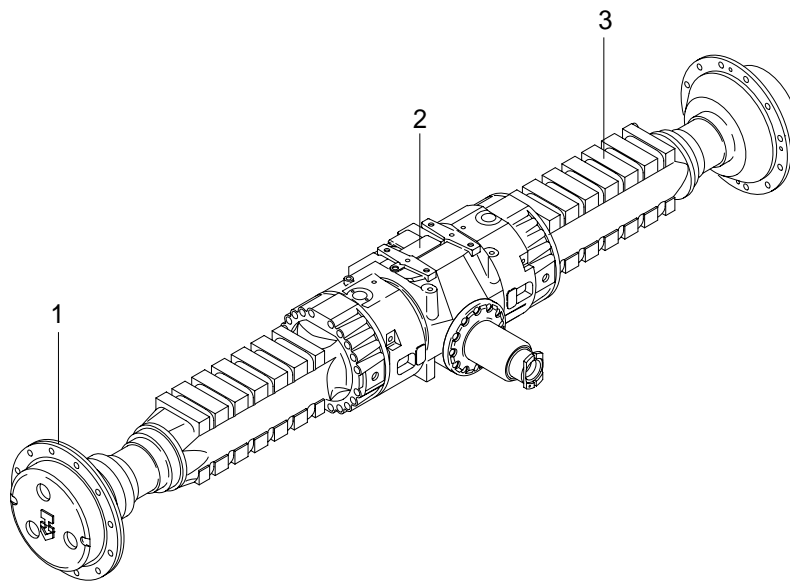

1 Final drive

2 Differential

3 Axle

#### (2) Rear axle

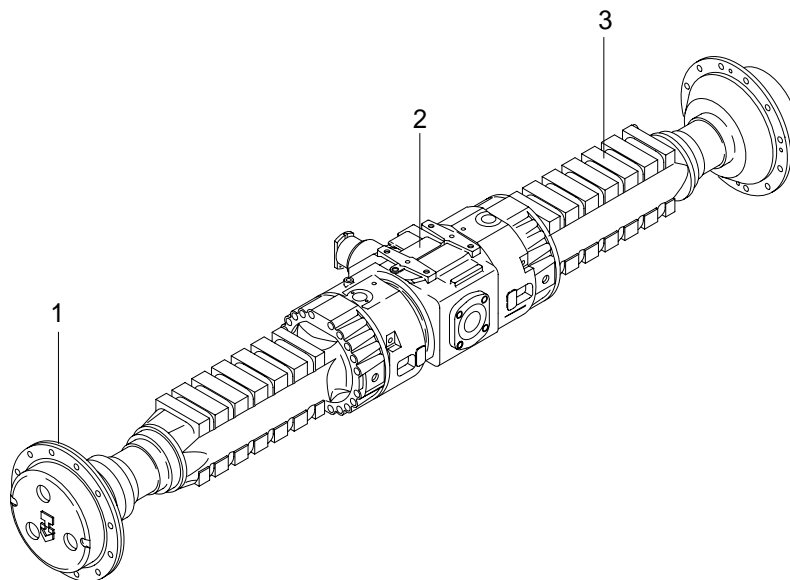

1 Final drive

2 Differential

3 Axle

## 2) SECTION OF FRONT AXLE DIFFERENTIAL

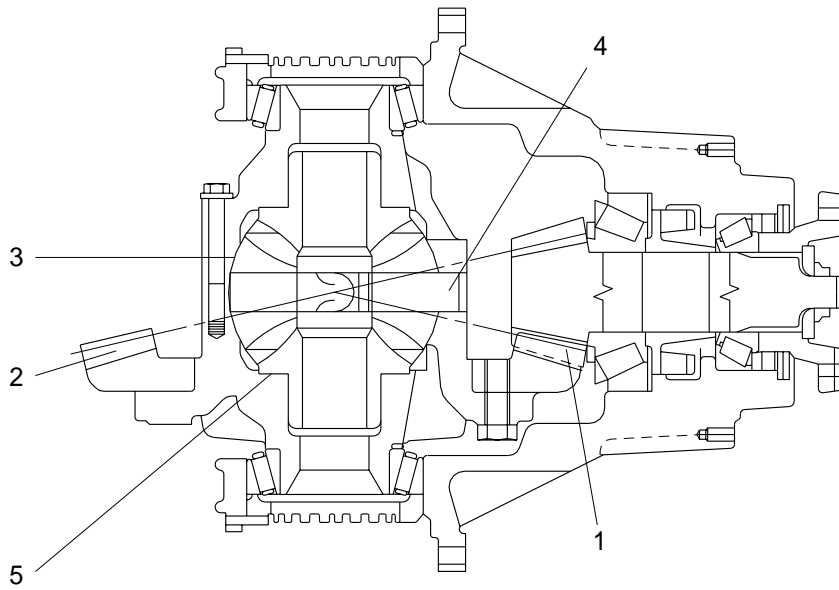
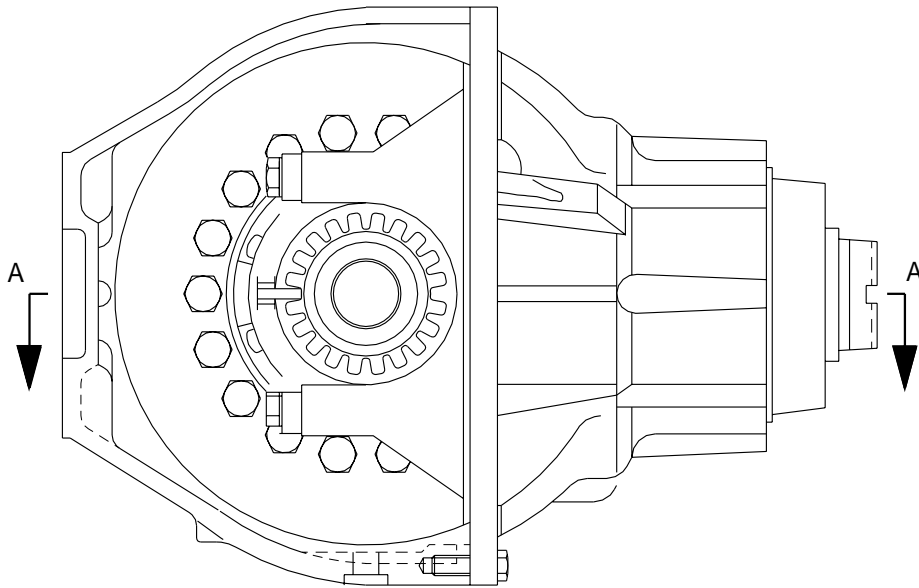

SECTION A-A

- |   |              |   |           |   |                         |
|---|--------------|---|-----------|---|-------------------------|
| 1 | Bevel pinion | 3 | Sun gears | 5 | Side gear(Differential) |
| 2 | Bevel gear   | 4 | Shaft     |   |                         |



### 3) SECTION OF REAR AXLE DIFFERENTIAL

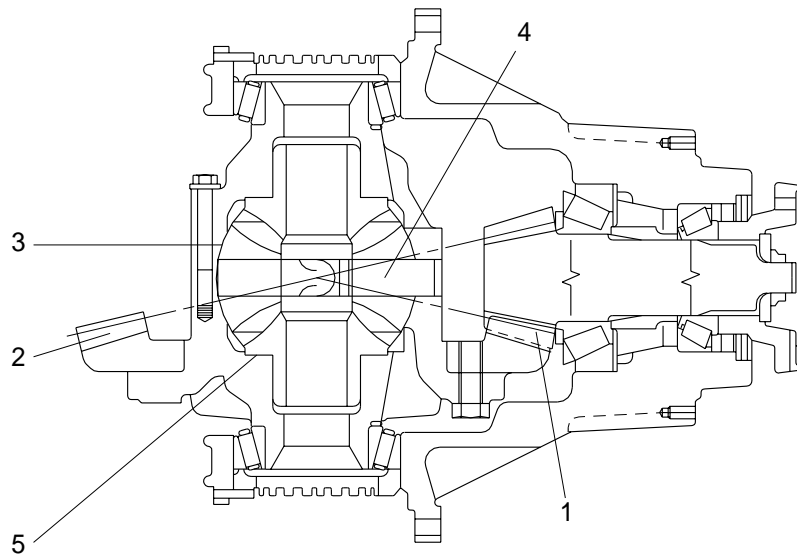
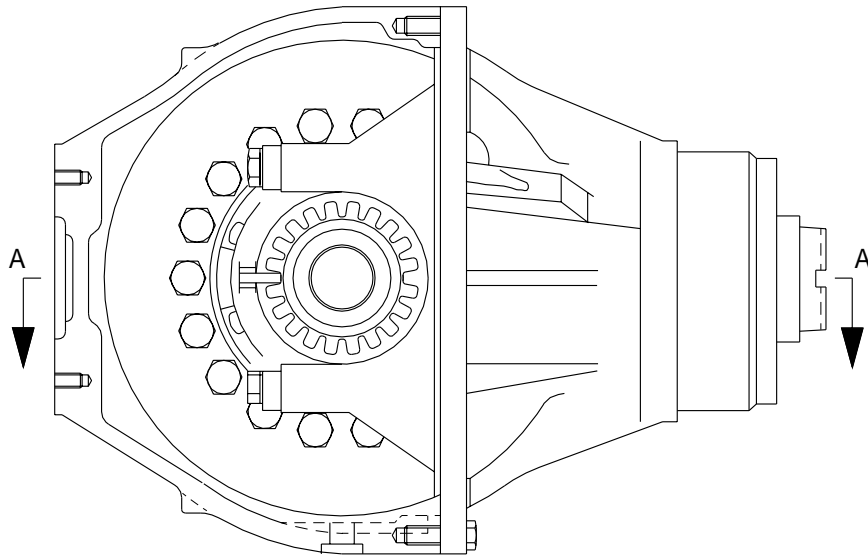

SECTION A-A

- |   |              |   |           |   |                         |
|---|--------------|---|-----------|---|-------------------------|
| 1 | Bevel pinion | 3 | Sun gears | 5 | Side gear(Differential) |
| 2 | Bevel gear   | 4 | Shaft     |   |                         |

#### 4) DIFFERENTIAL

##### (1) Description

When the machine makes a turn, the outside wheel must rotate faster than the inside wheel. A differential is a device which continuously transmits power to the right and left wheels while allowing them to turn at different speeds, during a turn.

The power from the drive shaft passes through bevel pinion(1) and is transmitted to the bevel gear(2). The bevel gear changes the direction of the motive force by 90 degree, and at the same time reduces the speed.

It then transmits the motive force through the differential(3) to the axle gear shaft(4).

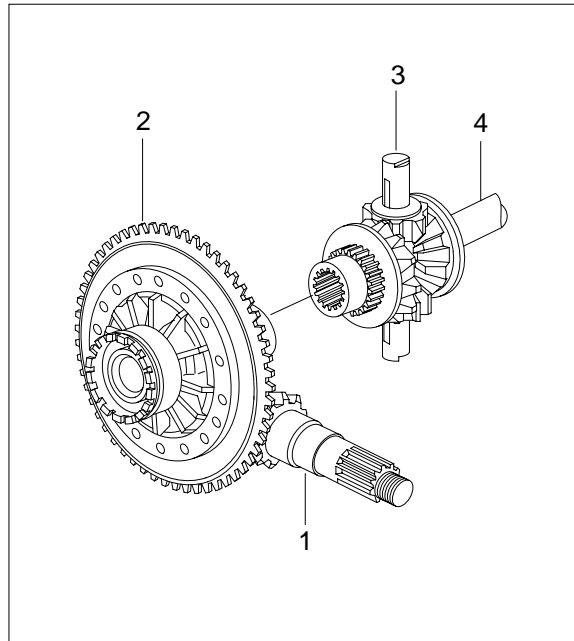

##### (2) When driving straight forward

When the machine is being driven straight forward and the right and left wheels are rotating at the same speed, so the pinion gear inside the differential assembly do not rotate. The motive force of the carrier is sent through the pinion gear and the side gear, therefore the power is equally transmitted to the left and right axle gear shaft.

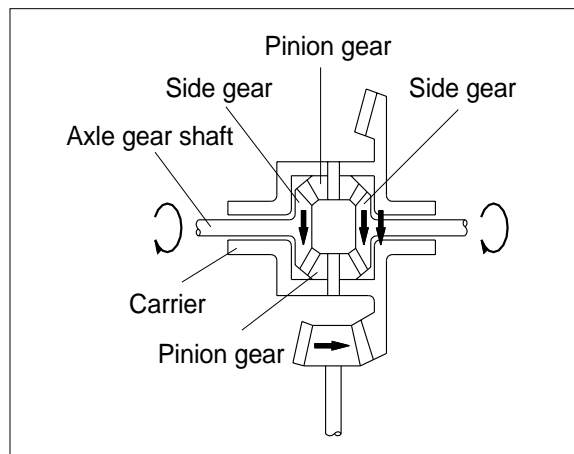

##### (3) When turning

When turning, the rotating speed of the left and right wheels is different, so the pinion gear and side gear inside the differential assembly rotate in accordance with the difference between the rotating speed of the left and right wheels.

The power of the carrier is then transmitted to the axle gear shafts.

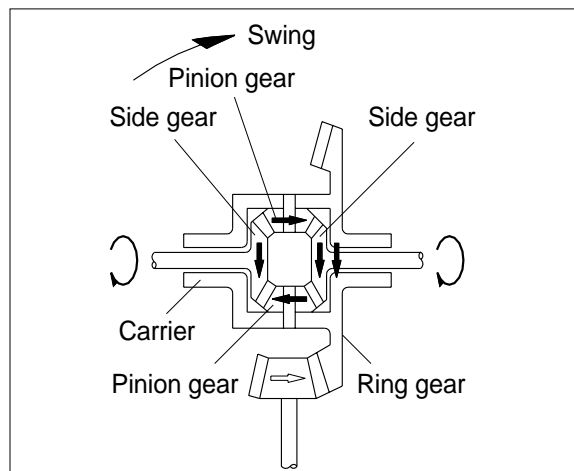

## 5) TORQUE PROPORTIONING DIFFERENTIAL

### (1) Function

① Because of the nature of their work, 4-wheel-drive loaders have to work in places where the road surface is bad.

In such places, if the tires slip, the ability to work as a loader is reduced, and also the life of the tire is reduced.

The torque proportioning differential is installed to overcome this problem.

In structure it resembles the differential of an automobile, but the differential pinion gear has an odd number of teeth.

Because of the difference in the resistance from the road surface, the position of meshing of the pinion gear and side gear changes, and this changes the traction of the left and right tires.

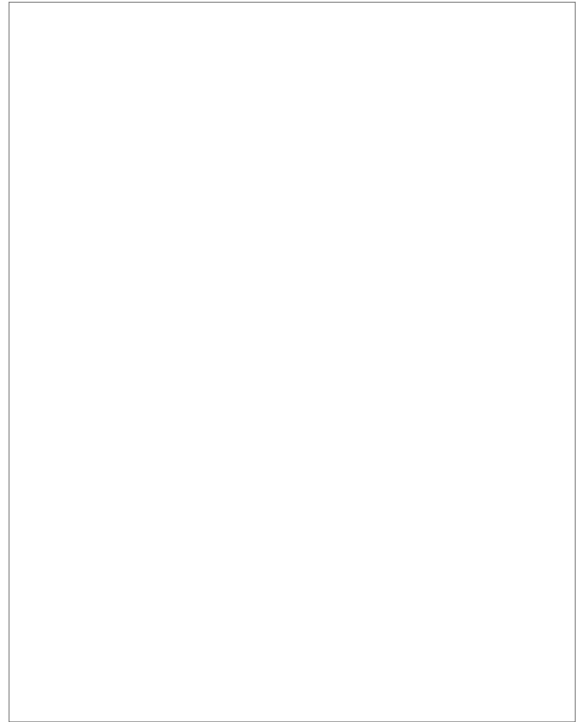

### (2) Operation

① **When traveling straight**(Equal resistance from road surface to left and right tires)

Under this condition, the distances involving the engaging points between right and left side gears and pinion-a and b-are equal and the pinion is balanced as  $FL \times a = FR \times b$ . Thus,  $FL = FR$ , and the right and left side gears are driven with the same force.

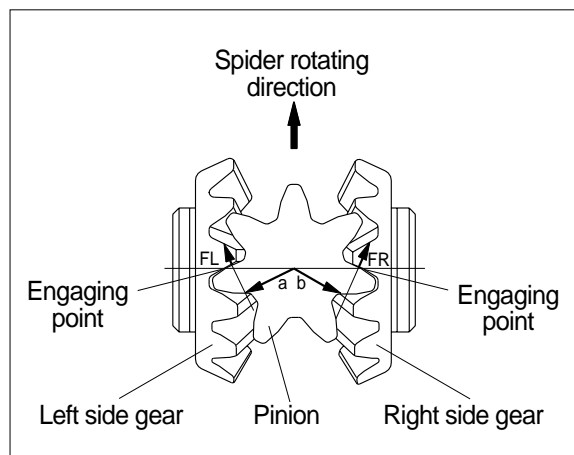

② **When traveling on soft ground**

(Resistance from road surface to left and right tires is different)

If the road resistance to the left wheel is smaller, the left side gear tends to rotate forward, and this rotation changes the engaging points between the side gears and pinion. As a result, the distances involving the engaging points becomes  $a > b$ . The pinion now is balanced as  $FL \times a = FR \times b$ , where  $FL > FR$ . The right side gear is driven with a greater force than the left side gear. The torque can be increased by up to about 30% for either side gear.

The pinion therefore does not run idle and driving power is transmitted to both side gears until the difference between road resistance to the right and left wheels reaches about 30%.

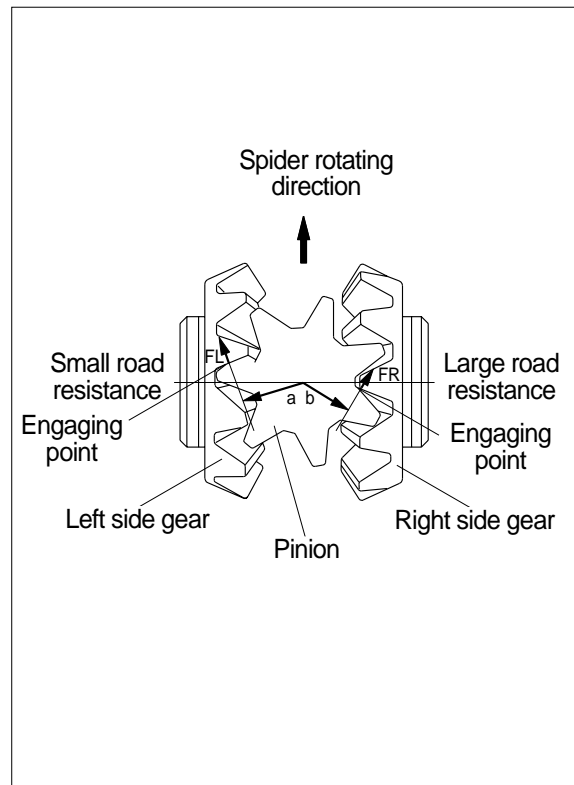

## 6) FINAL DRIVE(Front & rear)

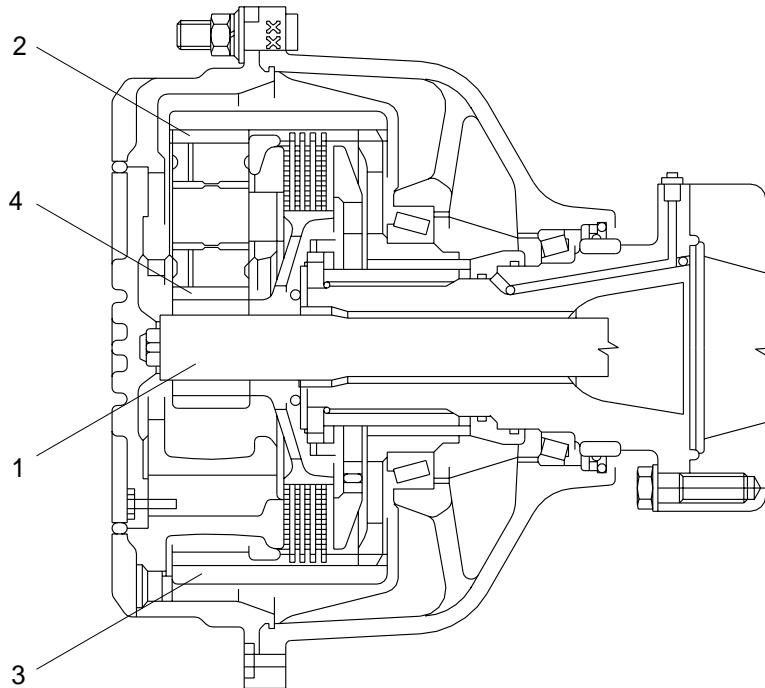

1 Axle shaft

2 Planetary gear

3 Ring gear

4 Sun gear

- (1) To gain a large drive force, the final drive uses a planetary gear system to reduce the speed and send drive force to the tires.
- (2) The power transmitted from the differential through axle shaft(1) to sun gear(4) is transmitted to planetary gear(2). The planetary gear rotates around the inside of a fixed ring gear(3) and in this way transmits rotation at a reduced speed to the planetary carrier. This power is then sent to the wheels which are installed to the planetary carriers.

## 6. TIRE AND WHEEL

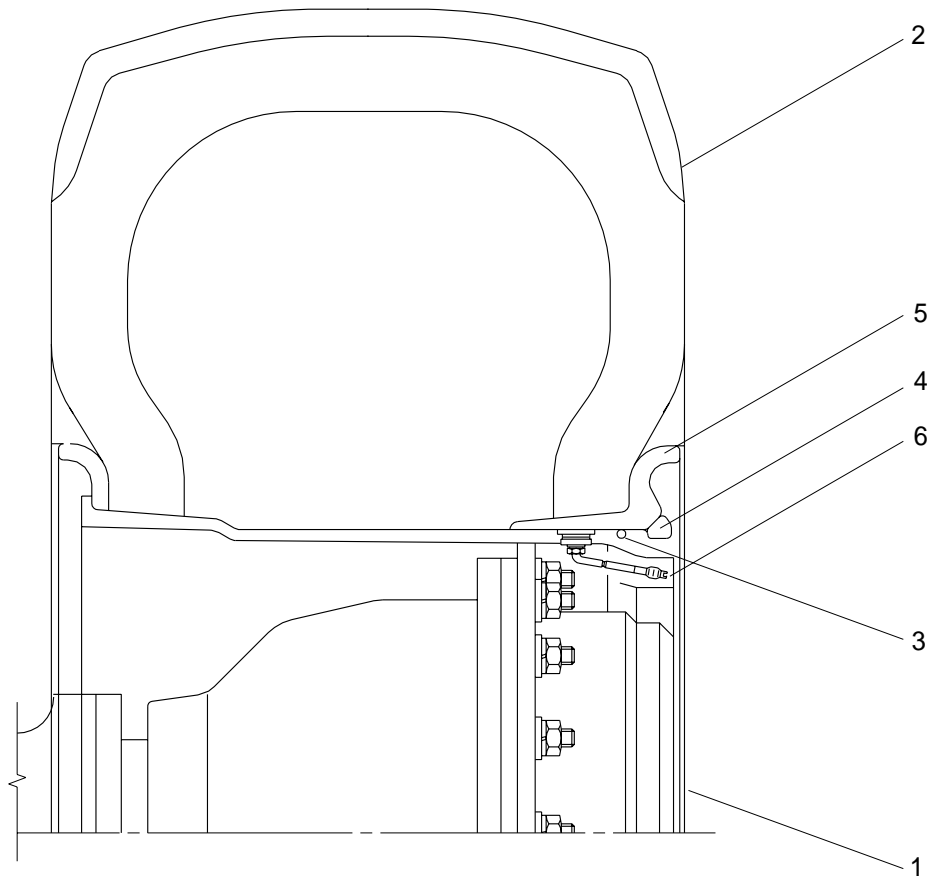

1 Wheel rim

2 Tire

3 O-ring

4 Lock ring

5 Side ring

6 Valve assembly

- 1) The tire acts to absorb the shock from the ground surface to the machine, and at the same time they must rotate in contact with the ground to gain the power which drives the machine.
- 2) Various types of tires are available to suit the purpose. Therefore it is very important to select the correct tires for the type of work and bucket capacity.