

GROUP 2 SPECIFICATIONS

1. MAJOR COMPONENT

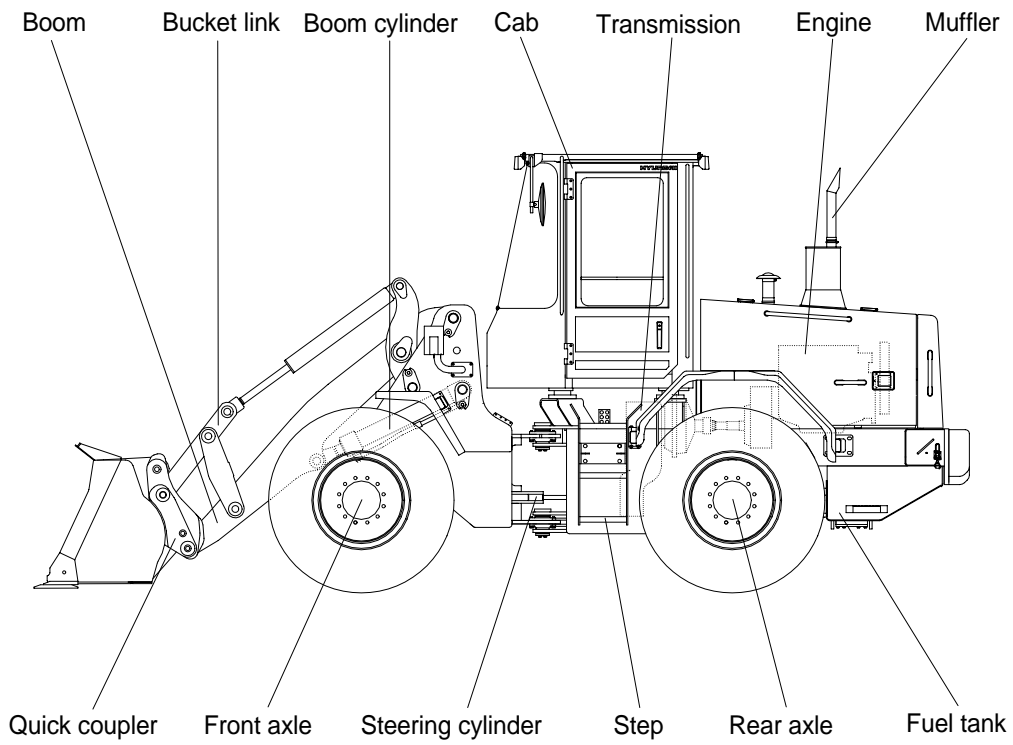
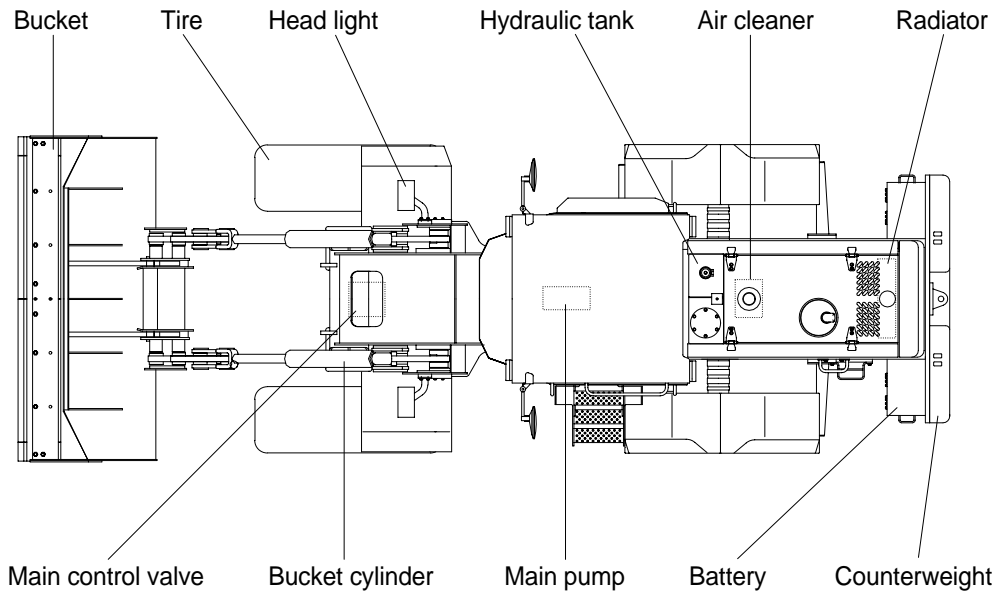

2. SPECIFICATIONS

1) WITHOUT CUTTING EDGE TYPE BUCKET

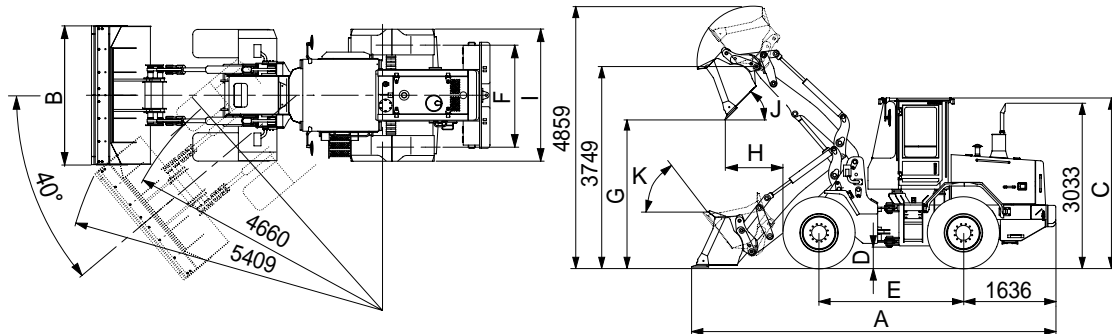

Description		Unit	Specification	
Operating weight		kg(lb)	9490(20920)	
Bucket capacity	Struck	m ³ (yd ³)	1.2(1.6)	
	Heaped		1.5(2.0)	
Overall length	A	mm(ft-in)	6742(22' 1")	
Overall width	B		2400(7' 10")	
Overall height	C		3180(10' 5")	
Ground clearance	D		373(1' 3")	
Wheelbase	E		2700(8' 10")	
Tread	F		1850(6' 1")	
Dump clearance at 45°	G		2818(9' 3")	
Dump reach	H		1048(3' 5")	
Width over tires	I		2295(7' 6")	
Dump angle	J		Degree (°)	50
Roll back angle(Carry position)	K			54
Cycle time	Lift(With load)	sec	5.3	
	Dump(With load)		1.4	
	Lower(Empty)		2.3	
Maximum travel speed		km/hr(mph)	38.1(23.6)	
Braking distance		m(ft-in)	13.9(45' 7")	
Minimum turning radius(Center of outside tire)			4.66(15' 3")	
Gradability		Degree (°)	30	
Travel speed	Forward	First gear	7.1(4.4)	
		Second gear	12.3(7.6)	
		Third gear	22.6(14.0)	
	Reverse	Fourth gear	38.1(23.6)	
		First gear	7.4(4.6)	
		Second gear	13.0(8.1)	
	Third gear	23.8(14.7)		

2) BOLT-ON CUTTING EDGE TYPE BUCKET

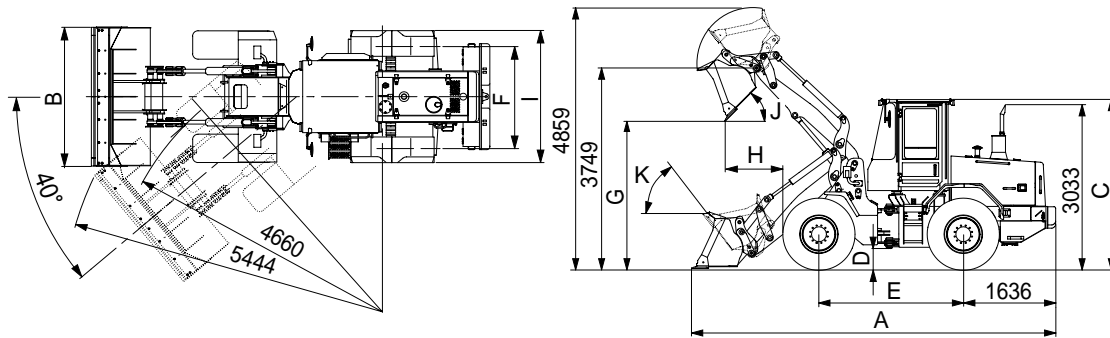

Description		Unit	Specification	
Operating weight		kg(lb)	9600(21160)	
Bucket capacity	Struck	m ³ (yd ³)	1.4(1.8)	
	Heaped		1.6(2.1)	
Overall length	A	mm(ft-in)	6812(22' 4")	
Overall width	B		2400(7' 10")	
Overall height	C		3180(10' 5")	
Ground clearance	D		373(1' 3")	
Wheelbase	E		2700(8' 10")	
Tread	F		1850(6' 1")	
Dump clearance at 45°	G		2754(9' 0")	
Dump reach	H		1080(3' 7")	
Width over tires	I		2295(7' 6")	
Dump angle	J		Degree (°)	50
Roll back angle(Carry position)	K			54
Cycle time	Lift(With load)	sec	5.3	
	Dump(With load)		1.4	
	Lower(Empty)		2.3	
Maximum travel speed		km/hr(mph)	38.1(23.6)	
Braking distance		m(ft-in)	13.9(45' 7")	
Minimum turning radius(Center of outside tire)			4.66(15' 3")	
Gradability		Degree (°)	30	
Travel speed	Forward	First gear	7.1(4.4)	
		Second gear	12.3(7.6)	
		Third gear	22.6(14.0)	
		Fourth gear	38.1(23.6)	
	Reverse	First gear	7.4(4.6)	
		Second gear	13.0(8.1)	
Third gear		23.8(14.7)		

3. WEIGHT

Item	kg	lb
Front frame assembly	828	1825
Rear frame assembly	801	1766
Front fender(2EA)	28	62
Rear fender(2EA)	38	84
Counterweight	495	1091
Cab assembly	640	1411
Engine assembly	380	838
Transmission	360	794
Drive shaft(Engine to transmission)	7	15
Drive shaft(Front)	16	35
Drive shaft(Center)	17	37
Drive shaft(Rear)	10	22
Front axle(Include differential)	475	1047
Rear axle(Include differential)	485	1069
Tire(4EA)	816	1799
Hydraulic tank	92	203
Fuel tank	158	348
Main pump assembly	25	55
Main control valve	55	121
Boom	490	1080
Link(Boom to bucket link, 4EA)	65	143
Bucket link(2EA)	82	181
1.6m ³ bucket, with bolt on cutting edge	722	1592
1.5m ³ bucket, without cutting edge	600	1323
Boom cylinder assembly(2EA)	160	353
Bucket cylinder assembly(2EA)	94	207
Steering cylinder assembly(2EA)	36	79
Quick coupler cylinder(1EA)	5.5	12
Seat	40	88
Battery	44	97
Link(Boom to bucket cylinder, 4EA)	52	115
Link(Front frame to link)	10	22
Quick coupler assembly	215	474

4. SPECIFICATION FOR MAJOR COMPONENTS

1) ENGINE

Item	Specification
Model	Deutz BF4M1012EC
Type	4-cycle turbocharged and aftercooled diesel engine
Cooling method	Water cooling
Number of cylinders and arrangement	4 cylinders, in-line
Firing order	1-3-4-2
Combustion chamber type	Direct injection type
Cylinder bore × stroke	94 × 115mm(3.7" × 4.52")
Piston displacement	3190cc(195cu in)
Compression ratio	17.5 : 1
Rated gross horse power	106ps at 2300rpm
Maximum gross torque at 1500rpm	38.5kgf · m(279lbf · ft)
Engine oil quantity	14.0 l (3.7 U.S. gal)
Dry weight	382kg(842lb)
High idling speed	2450 ± 50rpm
Low idling speed	925 ± 25rpm
Rated fuel consumption	160.3g/ps.h
Starting motor	BOSCH(24V)
Alternator	BOSCH(24V-55AMP)
Battery	2 × 12V × 100Ah

2) MAIN PUMP

Item	Specification
Type	Fixed displacement tandem gear pump
Capacity	33+29cc/rev
Maximum operating pressure	215kgf/cm ² (3058psi)
Rated oil quantity	139 l /min(35.7U.S.gpm)
Rated speed	2300rpm

3) BRAKE PUMP

Item		Specification
Type		Fixed displacement tandem gear pump
Capacity		5cc/rev
Maximum operating pressure		150kgf/cm ² (2130psi)
Rated oil quantity		11 l / min(2.9U.S.gpm)

4) MAIN CONTROL VALVE

Item		Specification
Type		2 spool
Operating method		Hydraulic pilot assist
Main relief valve pressure		215kgf/cm ² (3058psi)
Overload relief valve pressure(Raise, roll back)		240kgf/cm ² (3414psi)
Overload relief valve pressure(Dump)		120kgf/cm ² (1707psi)

5) REMOTE CONTROL VALVE

Item		Specification
Type		Pressure reducing type
Operating	Minimum	5.8kgf/cm ² (82.5psi)
	Maximum	30kgf/cm ² (427psi)
Single operation stroke	Lever	77mm(3.0in)

6) CYLINDER

Item		Specification
Boom cylinder	Bore dia × Rod dia × Stroke	∅ 105 × ∅ 65 × 710mm
Bucket cylinder	Bore dia × Rod dia × Stroke	∅ 95 × ∅ 50 × 760mm
Steering cylinder	Bore dia × Rod dia × Stroke	∅ 60 × ∅ 35 × 390mm
Quick coupler cylinder	Bore dia × Rod dia × Stroke	∅ 50 × ∅ 25 × 79mm

7) DYNAMIC POWER TRANSMISSION DEVICES

Item		Specification
Torque converter	Model	ZF 4WG130
	Type	Single-stage, single-phase
Transmission	Type	Full-automatic power shift
	Gear shift	Forward fourth gear, reverse third gear
	Adjustment	Electrical single lever type, kick-down system
Axle	Drive devices	4-wheel drive
	Front	Front fixed location
	Rear	Oscillation 13° of center pin-loaded
Wheels	Tires	17.5-25, 12PR(L3)
Brakes	Travel	Four-wheel, wet-disc type, full hydraulic
	Parking	Spring applied, hydraulic released brake on front axle
Steering	Type	Full hydraulic, articulated
	Steering angle	40° to both right and left angle, respectively

5. TIGHTENING TORQUE OF MAJOR COMPONENT

No.	Items	Size	kgf · m	lbf · ft	
1	Engine	Engine mounting bolt, nut	M12×1.75	12.3 ± 2.5	89.0 ±
2		Radiator mounting bolt, nut	M12×1.75	12.3 ± 2.5	18.1
3	Hydraulic system	Main pump housing mounting bolt	M14×2.0	19.6 ± 2.9	89.0 ±
4		Main control valve mounting bolt	M12×1.75	12.8 ± 3.0	18.1
5		Steering unit mounting bolt	M 8×1.25	2.5 ± 0.5	142 ±
6		Priority valve mounting bolt	M 8×1.25	2.5 ± 0.5	20.9
7		Brake valve mounting bolt	M 8×1.25	3.0 ± 0.3	92.6 ±
8		Fuel tank mounting bolt	M16×2.0	29.7 ± 4.5	21.7
9		Hydraulic oil tank mounting bolt	M12×1.75	12.3 ± 2.5	18.1 ± 3.6
10	Power train system	Transmission mounting bolt	M16×2.0	29 ± 5.0	18.1 ± 3.6
11		Front axle mounting bolt	M24×2.0	100 ±15.0	21.7 ± 2.2
12		Rear axle support mounting bolt, nut	M24×2.0	94.5 ±10.5	215 ±
13		Tire mounting nut	M22×1.5	70 ± 2.0	32.5
14		Drive shaft joint mounting bolt, nut	M20×2.5	57.9 ± 8.7	89.0 ± 18
15	Others	Counterweight mounting bolt	M24×2.0	107 ± 16.1	210 ±
16		Operator's seat mounting bolt	M 8×1.25	3.4 ± 0.8	36.2
17		ROPS Cab mounting bolt(4EA)	M24×3.0	28 ± 2.6	

6. TORQUE CHART

Use following table for unspecified torque.

1) BOLT AND NUT

(1) Coarse thread

Bolt size	8T		10T	
	kgf · m	lbf · ft	kgf · m	lbf · ft
M 6 × 1.0	0.85 ~ 1.25	6.15 ~ 9.04	1.14 ~ 1.74	8.2 ~ 12.6
M 8 × 1.25	2.0 ~ 3.0	14.5 ~ 21.7	2.73 ~ 4.12	19.7 ~ 29.8
M10 × 1.5	4.0 ~ 6.0	28.9 ~ 43.4	5.5 ~ 8.3	39.8 ~ 60
M12 × 1.75	7.4 ~ 11.2	53.5 ~ 79.5	9.8 ~ 15.8	71 ~ 114
M14 × 2.0	12.2 ~ 16.6	88.2 ~ 120	16.7 ~ 22.5	121 ~ 167
M16 × 2.0	18.6 ~ 25.2	135 ~ 182	25.2 ~ 34.2	182 ~ 247
M18 × 2.5	25.8 ~ 35.0	187 ~ 253	35.1 ~ 47.5	254 ~ 343
M20 × 2.5	36.2 ~ 49.0	262 ~ 354	49.2 ~ 66.6	356 ~ 482
M22 × 2.5	48.3 ~ 63.3	350 ~ 457	65.8 ~ 98.0	476 ~ 709
M24 × 3.0	62.5 ~ 84.5	452 ~ 611	85.0 ~ 115	615 ~ 832
M30 × 3.5	124 ~ 168	898 ~ 1214	169 ~ 229	1223 ~ 1655
M36 × 4.0	174 ~ 236	1261 ~ 1703	250 ~ 310	1808 ~ 2242

(2) Fine thread

Bolt size	8T		10T	
	kgf · m	lbf · ft	kgf · m	lbf · ft
M 8 × 1.0	2.17 ~ 3.37	15.7 ~ 24.3	3.04 ~ 4.44	22.0 ~ 32.0
M10 × 1.25	4.46 ~ 6.66	32.3 ~ 48.2	5.93 ~ 8.93	42.9 ~ 64.6
M12 × 1.25	7.78 ~ 11.58	76.3 ~ 83.7	10.6 ~ 16.0	76.6 ~ 115
M14 × 1.5	13.3 ~ 18.1	96.2 ~ 130	17.9 ~ 24.1	130 ~ 174
M16 × 1.5	19.9 ~ 26.9	144 ~ 194	26.6 ~ 36.0	193 ~ 260
M18 × 1.5	28.6 ~ 43.6	207 ~ 315	38.4 ~ 52.0	278 ~ 376
M20 × 1.5	40.0 ~ 54.0	289 ~ 390	53.4 ~ 72.2	386 ~ 522
M22 × 1.5	52.7 ~ 71.3	381 ~ 515	70.7 ~ 95.7	512 ~ 692
M24 × 2.0	67.9 ~ 91.9	491 ~ 664	90.9 ~ 123	658 ~ 890
M30 × 2.0	137 ~ 185	990 ~ 1338	182 ~ 248	1314 ~ 1795
M36 × 3.0	192 ~ 260	1389 ~ 1879	262 ~ 354	1893 ~ 2561

2) PIPE AND HOSE

Thread size	Width across flat(mm)	kgf · m	lbf · ft
1/4"	19	3	21.7
3/8"	22	4	28.9
1/2"	27	5	36.2
3/4"	36	12	86.8
1"	41	14	101

3) FITTING

Thread size	Width across flat(mm)	kgf · m	lbf · ft
1/4"	19	4	28.9
3/8"	22	5	36.2
1/2"	27	6	43.4
3/4"	36	13	94.0
1"	41	15	109

7. RECOMMENDED LUBRICANTS

Use only oils listed below or equivalent.

Do not mix different brand oil.

Service point	Kind of fluid	Capacity l (U.S. gal)	Ambient temperature °C(°F)								
			-20 (-4)	-10 (14)	0 (32)	10 (50)	20 (68)	30 (86)	40 (104)		
Engine oil pan	Engine oil	14(3.7)					SAE 30				
			SAE 10W								
			SAE 10W-30								
						SAE 15W-40					
Torque converter Transmission	Oil	20(5.3)	DEXRON II								
Axle	Gear oil	Front : 18.4(4.9) Rear : 18.4(4.9)	SAE 80W-90LSD/API GL-5								
Hydraulic tank	Hydraulic oil	Tank: 60(15.9) System: 87(23)	ISO VG 32								
						ISO VG 46					
						ISO VG 68					
Fuel tank	Diesel fuel	160(42.3)	ASTM D975 NO.1								
						ASTM D975 NO.2					
Fitting (Grease nipple)	Grease	As required	NLGI NO.1								
						NLGI NO.2					
Radiator	Mixture of antifreeze and water 50 : 50	30(7.9)	Ethylene glycol base permanent type								