

## SECTION 6 WORK EQUIPMENT

Group 1 Structure and Function .....	6-1
Group 2 Operational Checks and Troubleshooting .....	6-35
Group 3 Tests and Adjustments .....	6-45
Group 4 Disassembly and Assembly .....	6-60

# SECTION 6 WORK EQUIPMENT

## GROUP 1 STRUCTURE AND FUNCTION

### 1. HYDRAULIC SYSTEM OUTLINE

The loader hydraulic system is a pilot operated, open center system which is supplied with flow from the fixed displacement main hydraulic pump.

The pilot control system is a low pressure, closed center hydraulic system which is supplied with flow from the first (steering) pump.

The loader system components are :

- Main pump
- Main control valve
- Bucket cylinder
- Boom cylinders
- Pilot supply unit
- Remote control valve (Pilot control valve)
- Safety valve

The pilot supply unit consists of the pressure reducing valve, relief valve and accumulator.

Flow from the main hydraulic pump not used by the steering system leaves the priority valve EF port. It flows to the inlet port plate of four blocks type main control valve.

The main control valve is open center system which routes flow to the boom, bucket or auxiliary cylinders (not shown) when the respective spools are shifted.

Flow from the steering pump is routed to the pilot supply unit where the steering pump outlet pressure is reduced to pilot circuit pressure. The pilot supply unit control valve flow to the remote control valve.

The remote control valve routed flow to either end of each spool valve section in the main control valve to control spool stroke.

A accumulator mounted on pilot supply unit supplies a secondary pressure source to operated remote control valve so the boom can be lowered if the engine is off.

The return circuit for the main hydraulic system have return filter inside the hydraulic tank. The return filter uses a filter element and a bypass valve. The bypass valve is located in the upside of filter.

## 2. HYDRAULIC CIRCUIT

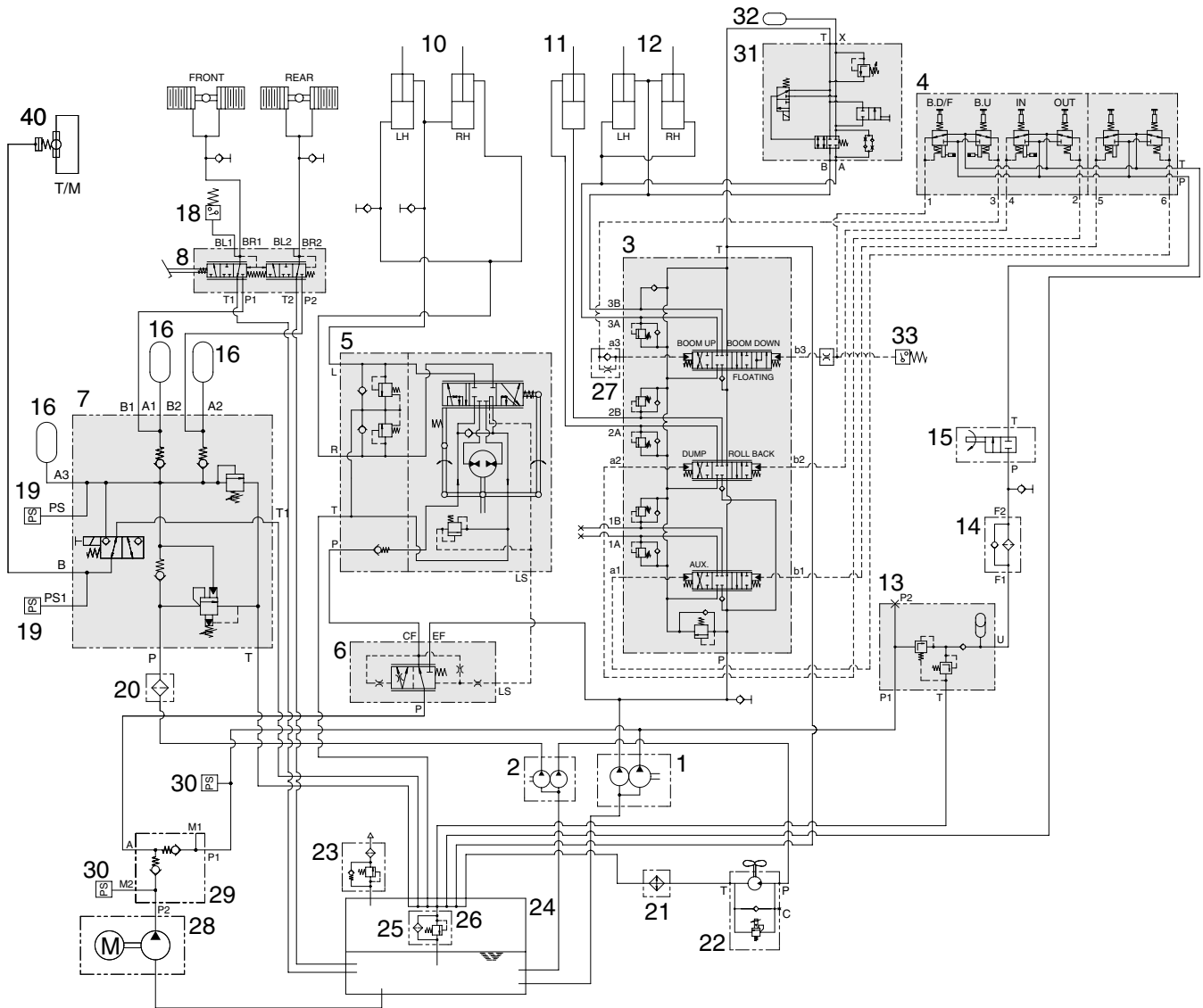

7309SB6WE01

- |    |                      |    |                   |    |                          |
|----|----------------------|----|-------------------|----|--------------------------|
| 1  | Main pump            | 13 | Pilot supply unit | 25 | Return filter            |
| 2  | Fan & brake pump     | 14 | Line filter       | 26 | Bypass valve             |
| 3  | Main control valve   | 15 | Safety valve      | 27 | Shockless valve          |
| 4  | Remote control valve | 16 | Accumulator       | 28 | Pump motor (opt)         |
| 5  | Steering unit        | 18 | Pressure switch   | 29 | Check valve (opt)        |
| 6  | Priority valve       | 19 | Pressure sensor   | 30 | Pressure sensor (opt)    |
| 7  | Cut off valve        | 20 | Line filter       | 31 | Ride control valve (opt) |
| 8  | Brake valve          | 21 | Oil cooler        | 32 | Accumulator (opt)        |
| 10 | Steering cylinder    | 22 | Fan motor         | 33 | Pressure switch (opt)    |
| 11 | Bucket cylinder      | 23 | Air breather      | 40 | Parking brake on T/M     |
| 12 | Boom cylinder        | 24 | Hydraulic tank    |    |                          |

### 3. WORK EQUIPMENT HYDRAULIC CIRCUIT

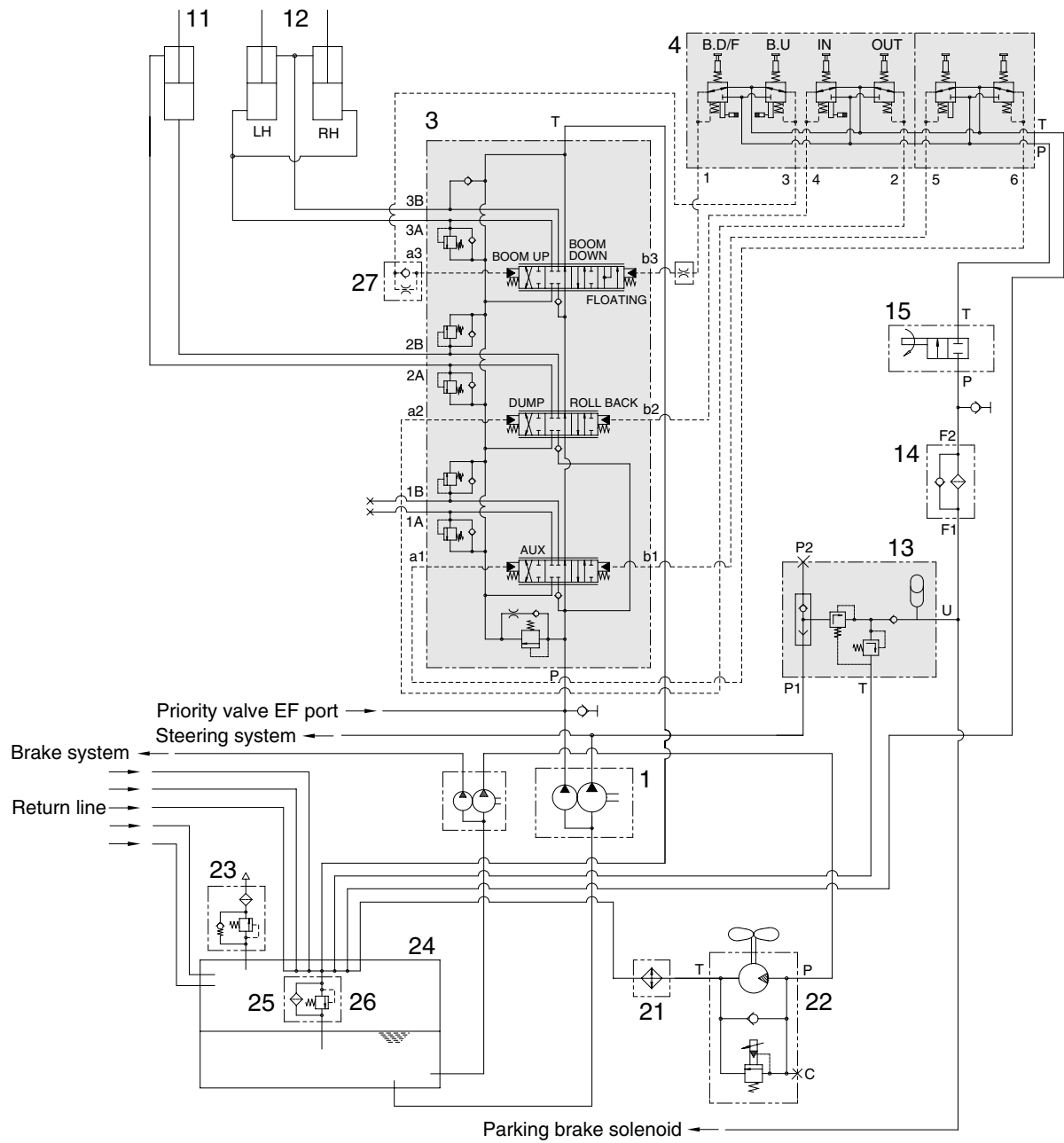

7409S6WE02

- |    |                      |    |                   |    |                 |
|----|----------------------|----|-------------------|----|-----------------|
| 1  | Main pump            | 13 | Pilot supply unit | 23 | Air breather    |
| 3  | Main control valve   | 14 | Line filter       | 24 | Hydraulic tank  |
| 4  | Remote control valve | 15 | Safety valve      | 25 | Return filter   |
| 11 | Bucket cylinder      | 21 | Oil cooler        | 26 | Bypass valve    |
| 12 | Boom cylinder        | 22 | Fan motor         | 27 | Shockless valve |



## 2) WHEN THE RCV LEVER IS IN THE LOWER POSITION

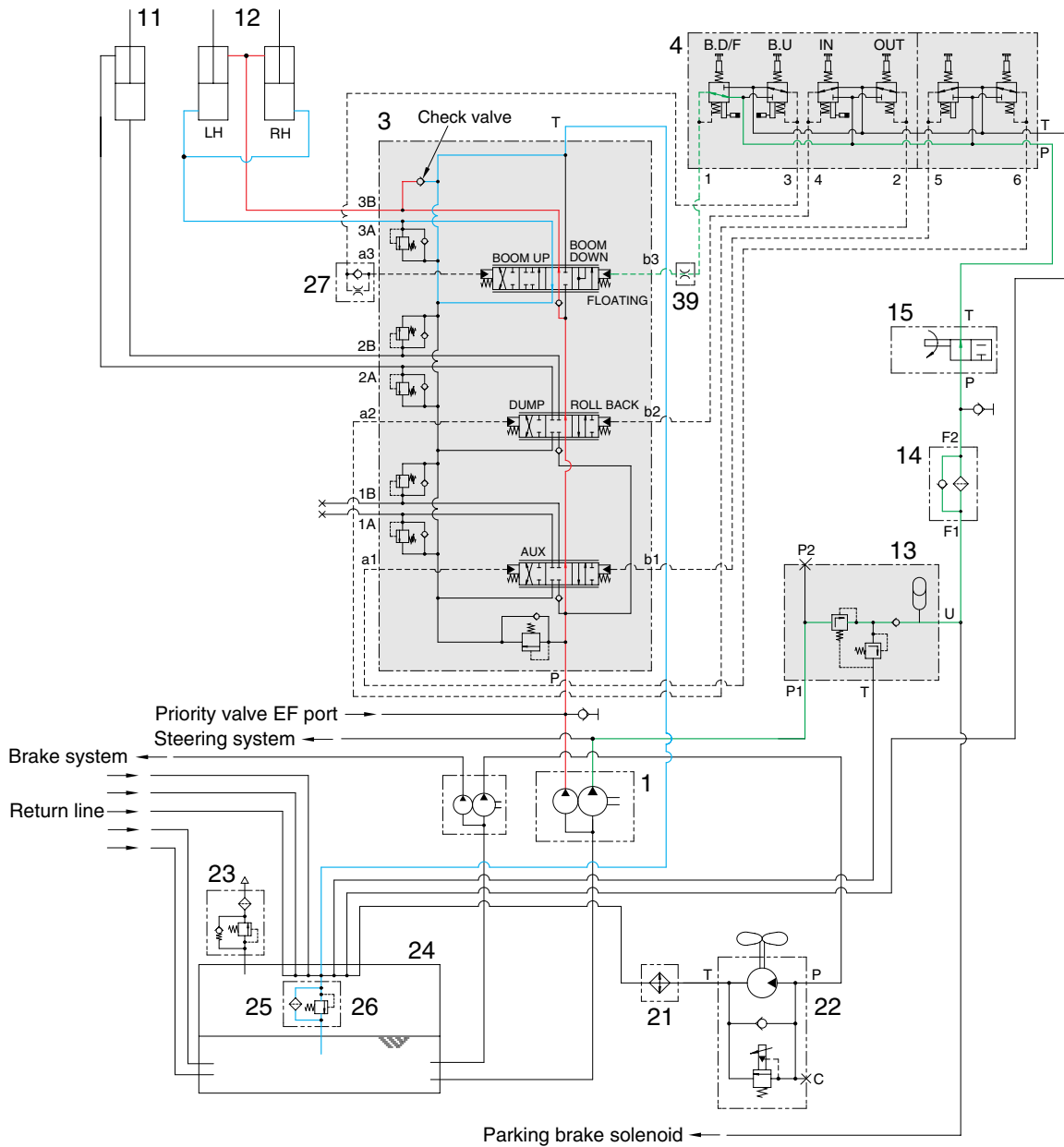

7409S6WE04

- When the RCV lever (4) is pushed forward, the boom spool is moved to lower position by pilot pressure from port 1 of RCV through orifice connector (39).
  - The oil from main pump (1) flows into main control valve (3) and then goes to small chamber of boom cylinder (12) by pushing the load check valve of the boom spool.
  - The oil returned from large chamber of boom cylinder (12) returns to hydraulic tank (24) through the boom spool at the same time.
  - When the lowering speed of boom is faster, the return oil from the large chamber of boom cylinder combines with the oil from the pump through the check valve, and flows into the small chamber of the cylinder.
- This prevents cylinder cavitation by the negative pressure when the pump flow cannot match the boom down speed.

### 3) WHEN THE RCV LEVER IS IN THE FLOAT POSITION

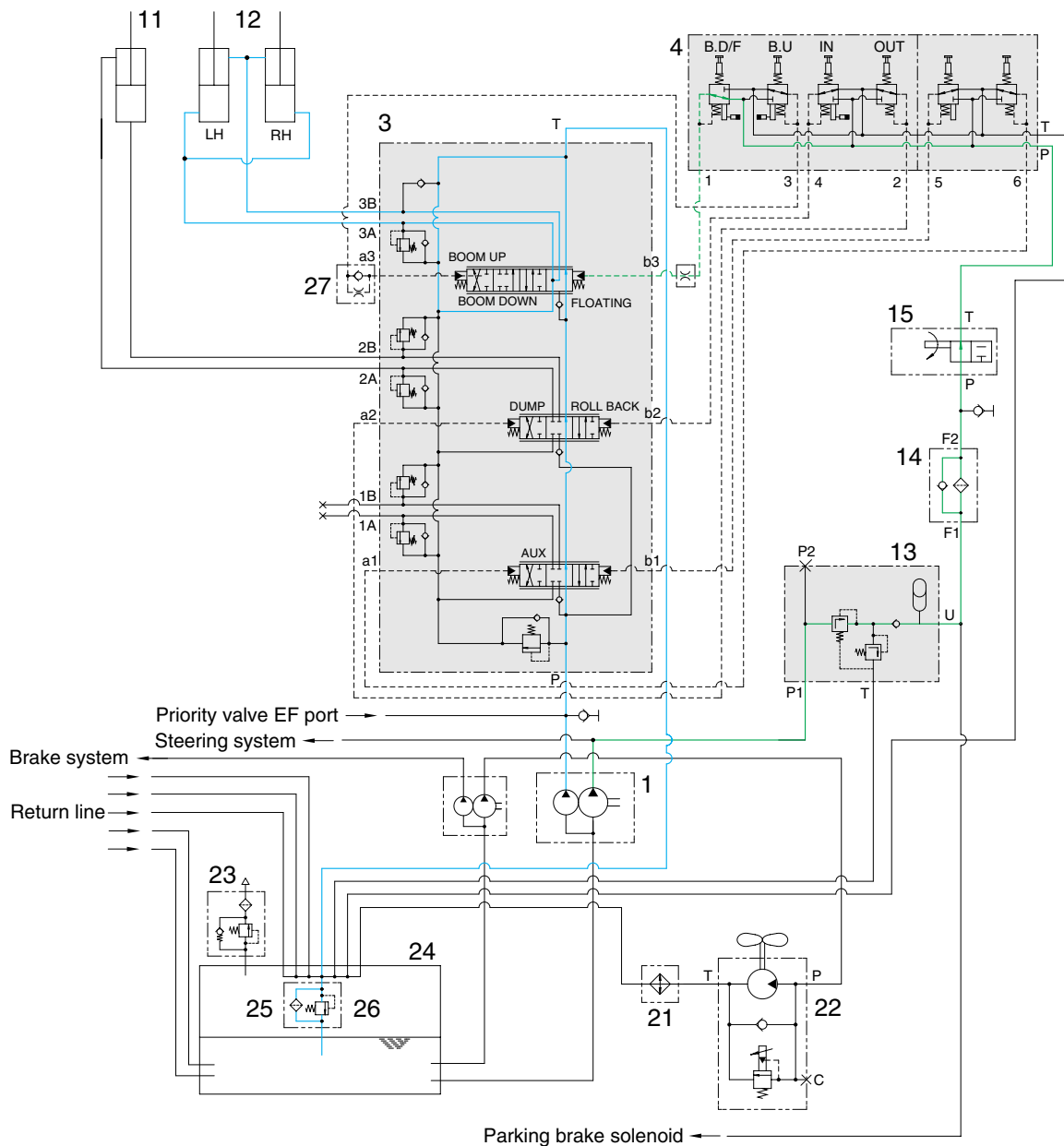

7409S6WE05

- When the RCV lever (4) is pushed further forward from the lower position, the pilot pressure reaches to 13~15bar, then the boom spool is moved to floating position.
- The work ports (3A), (3B) and the small chamber and the large chamber are connected to the return passage, so the boom will be lowered due to it's own weight.
- In this condition, when the bucket is in contact with the ground, it can be move up and down in accordance with the shape of the ground.

#### 4) WHEN THE RCV LEVER IS IN THE DUMP POSITION

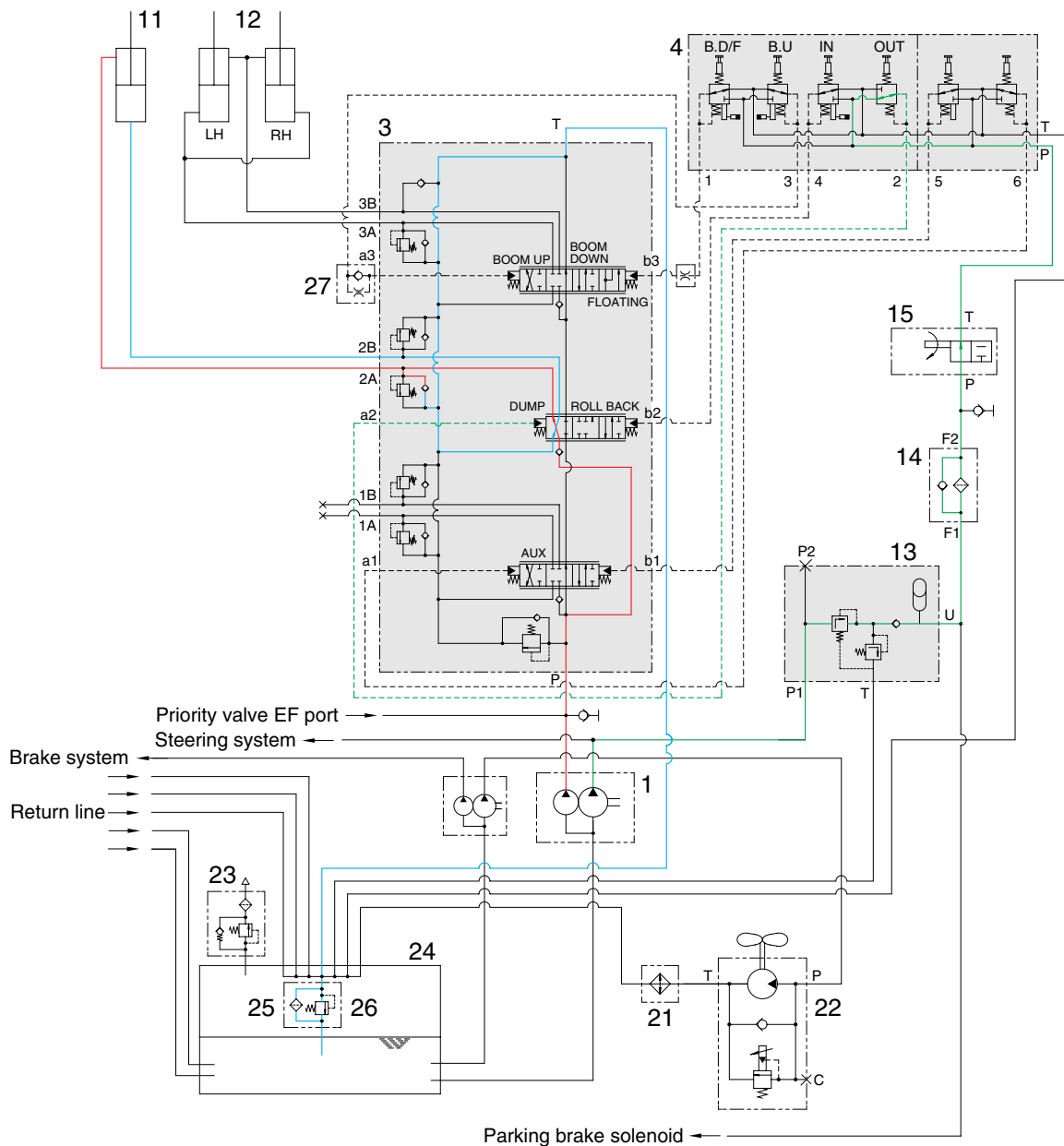

7409S6WE06

- If the RCV lever (4) is pushed right, the bucket spool is moved to dump position by pilot oil pressure from port 2 of RCV.
- The oil from main pump (1) flows into main control valve (3) and then goes to the small chamber of bucket cylinder (11) by pushing the load check valve of the bucket spool.
- The oil at the large chamber of bucket cylinder (11) returns to hydraulic tank (24).
- When this happens, the bucket is dumped.
- When the dumping speed of bucket is faster, the oil returned from the large chamber of bucket cylinder combines with the oil from the pump, and flows into the small chamber of the cylinder. This prevents cylinder cavitation by the negative pressure when the pump flow cannot match the bucket dump speed.



## 5) WHEN THE RCV LEVER IS IN THE ROLL BACK (retract) POSITION

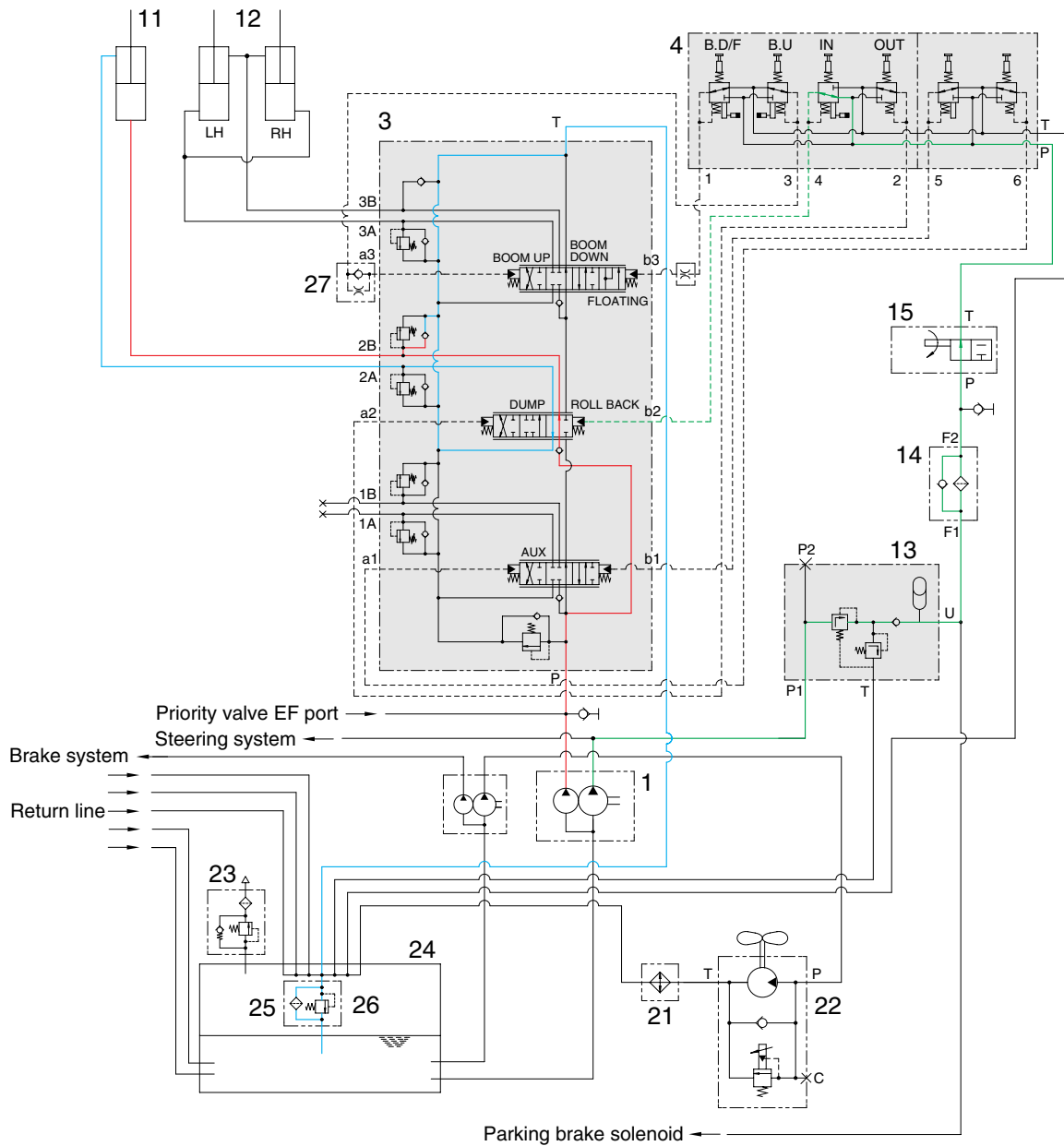

7409S6WE07

- If the RCV lever (4) is pulled left, the bucket spool is moved to roll back position by pilot oil pressure from port 4 of RCV.
- The oil from main pump (1) flows into main control valve (3) and then goes to the large chamber of bucket cylinder by pushing the load check valve of the bucket spool.
- The oil at the chamber of bucket cylinder (11) returns to hydraulic tank (24).
- When this happens, the bucket roll back.

## 6) WHEN THE RCV LEVER IS IN THE HOLD POSITION

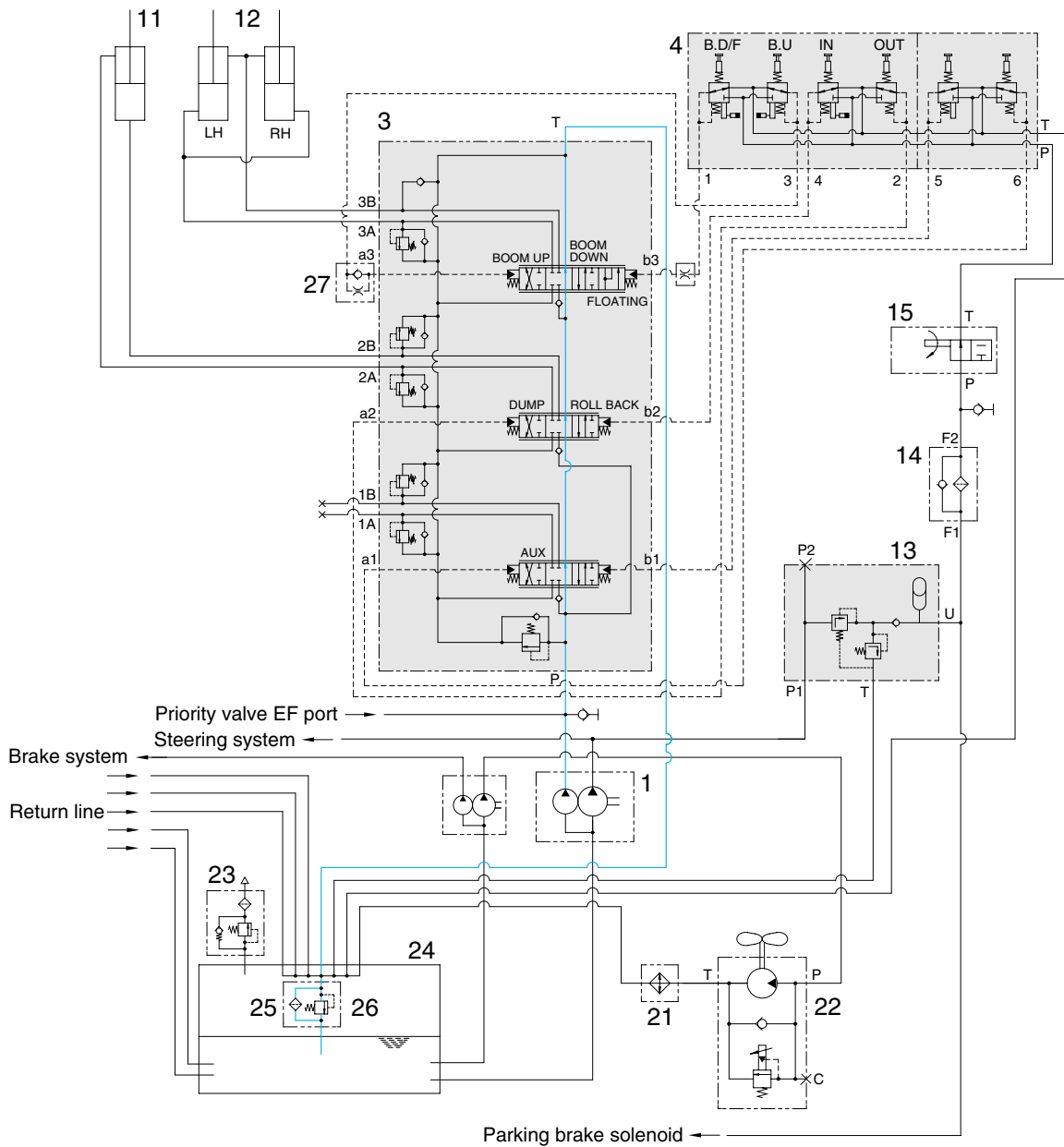

7409S6WE08

- The oil from main pump (1) flows into main control valve (3)
- In this time, the bucket spool, the boom spool and the boom float spool are in neutral position, then the oil supplied to main control valve (3) returns into hydraulic tank (24) through center bypass circuit of each spool.
- In this condition, each cylinder keeps the neutral position, so the boom and the bucket is held.

## 4. MAIN PUMP

### 1) STRUCTURE

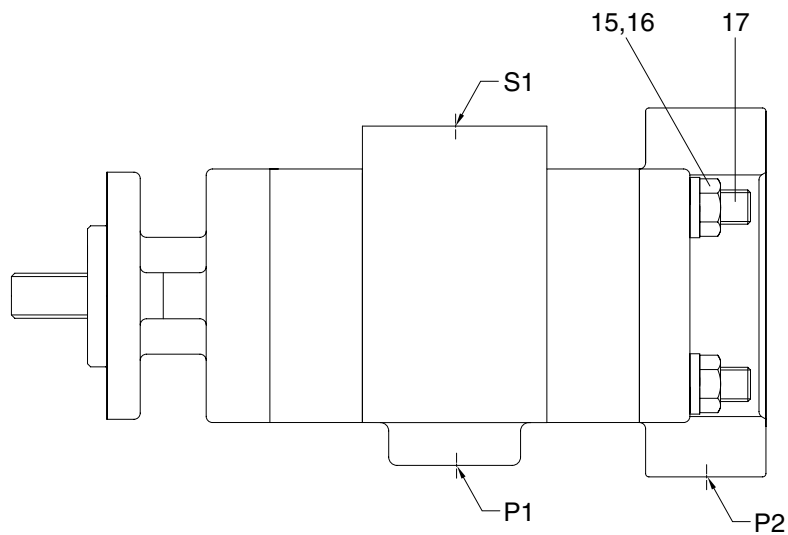
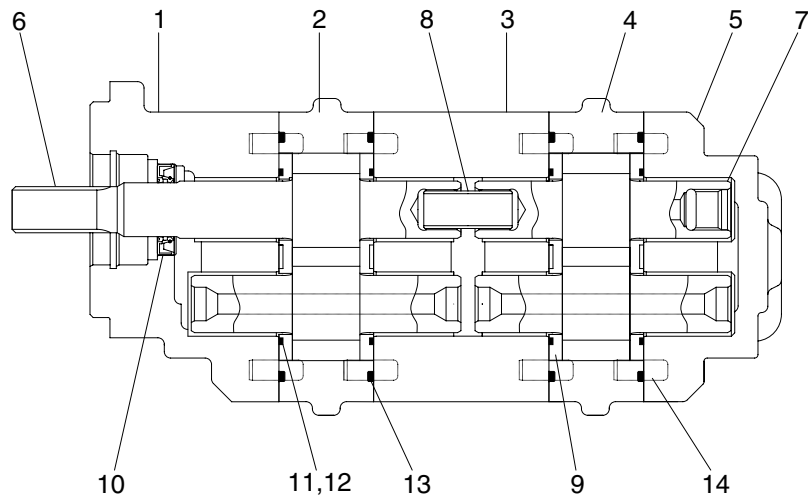

Port	Port name	Port size
P1	Pressure port (to steering valve)	1" split flange
P2	Pressure port (to MCV)	1" split flange
S1	Suction port	2" split flange

7309S6WE29

- |   |                |    |                  |    |             |
|---|----------------|----|------------------|----|-------------|
| 1 | Cover          | 7  | Driven gear set  | 13 | Square seal |
| 2 | Housing        | 8  | Connecting shaft | 14 | Dowel pin   |
| 3 | Carrier        | 9  | Thrust plate     | 15 | Washer      |
| 4 | Housing        | 10 | Lip seal         | 16 | Hexagon nut |
| 5 | Cover          | 11 | Rubber seal      | 17 | Stud bolt   |
| 6 | Drive gear set | 12 | Back up seal     |    |             |

## 2) OPERATION

The main hydraulic pump is a fixed displacement gear type pump. The pump is driven at engine speed by the transmission. The pump shafts are supported by lip seal (10), front cover (1), housing (2, 4) and rear cover (5). The thrust plate (9) are located between the gear surface and front cover (1), housing (2, 4) and rear cover (5).

As the drive gear (6) turns the driven gears (7), the gear teeth come out of mesh. Oil flows from the hydraulic tank through the inlet into the cavity between the gear teeth. As the gears continue to rotate, the oil becomes trapped between the gear teeth and housing (2, 4).

The trapped oil is then carried to the pump outlet. Oil is forced out the outlet to supply the hydraulic function. As the gears re-mesh, they form a seal to prevent oil from flowing between the gears and back to the inlet.

The pump uses outlet pressure oil to load the thrust plate (9) against the gear faces. This controls internal leakage to maintain pump displacement.

Outlet pressure fills the area bounded by the pressure balance moulded seals (13) to force the thrust plate against the high pressure area or the gear faces.

## 5. REMOTE CONTROL VALVE

### 1) STRUCTURE

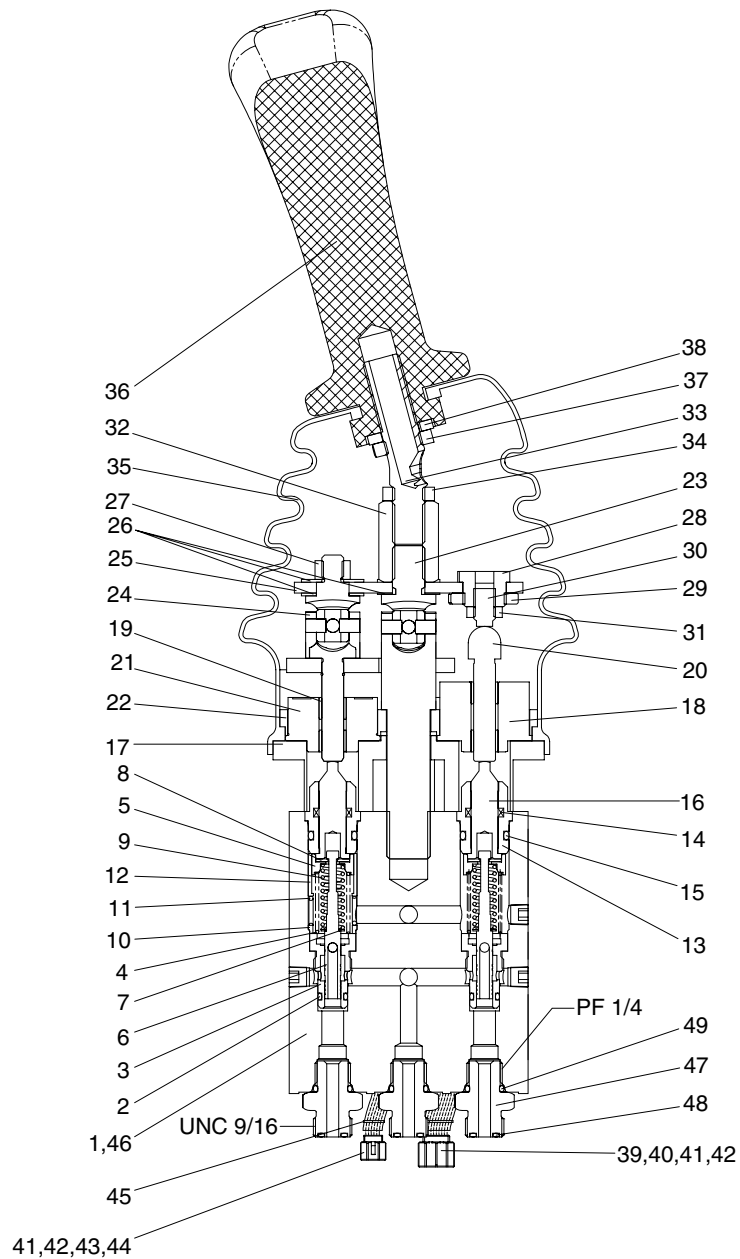

1	Body	14	Rod seal	27	Nut	40	Rear holder
2	O-ring	15	O-ring	28	Plug	41	Terminal
3	Plug	16	Push rod	29	Nut	42	Seal wire
4	Spring	17	Plate	30	Set screw	43	Housing
5	Spring seat	18	Rod stopper	31	Nut	44	Rear holder
6	Spool	19	Bushing	32	Nut	45	Clip band
7	Spring seat	20	Rod	33	Handle bar	46	Plug
8	Stopper	21	Magnet	34	Nut	47	Connector
9	Spring	22	Plate	35	Boot	48	O-ring
10	Spring seat	23	Joint assy	36	Handle assy	49	O-ring
11	Spring	24	Joint assy	37	Nut		
12	Spring seat	25	Plate	38	Spring washer		
13	Plug	26	Washer	39	Housing		

7407S6WE28

## 2) OPERATION

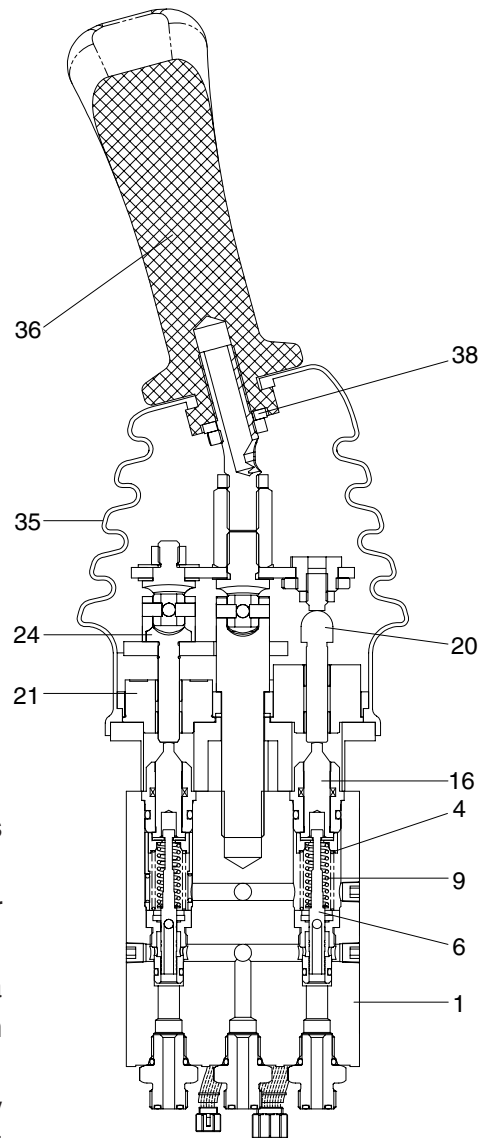
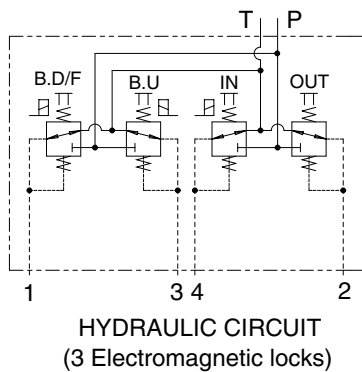

7407S6WE27

### (1) Hydraulic functional principle

Pilot devices with end position locks operate as direct operated pressure reducing valves.

They basically comprise of handle (36), four pressure reducing valves, body (1) and locks.

Each pressure reducing valve comprises of a control spool (6), a control spring (9), a return spring (4), push rod (16) and rod (20).

At rest, handle (36) is held in its neutral position by return springs (4). Ports (1, 2, 3, 4) are connected to tank port T via drilling.

When handle (36) is deflected, rod (20) is pressed against return spring (4) and control spring (9). Control spring (9) initially moves control spool (6) downwards and closes the connection between the relevant port and tank port T. At the same time the relevant port is connected to port P via drilling. The control phase starts as soon as control spool (6) finds its balance between the force from control spring (9) and the force, which results from the hydraulic pressure in the relevant port (ports 1, 2, 3 or 4).

Due to the interaction between control spool (6) and control spring (9) the pressure in the relevant port is proportional to the stroke of rod (20) and hence to the position of handle (36).

This pressure control which is dependent on the position of the handle (36) and the characteristics of the control spring permits the proportional hydraulic control of the main directional valves and high response valves for hydraulic pumps.

A rubber boot (35) protects the mechanical components in the housing from contamination.

## **(2) End position lock**

Only those control ports, for which it is necessary to hold the handle in a deflected position are equipped with end position locks.

### **Electromagnetic lock**

When this threshold is overcome, a joint assy (24) contacts the magnet (21); if the magnet (21) is energized, then handle (36) is held in its end position by magnetic force.

This lock is released automatically when the solenoid is deenergized.

## 6. MAIN CONTROL VALVE

### 1) STRUCTURE

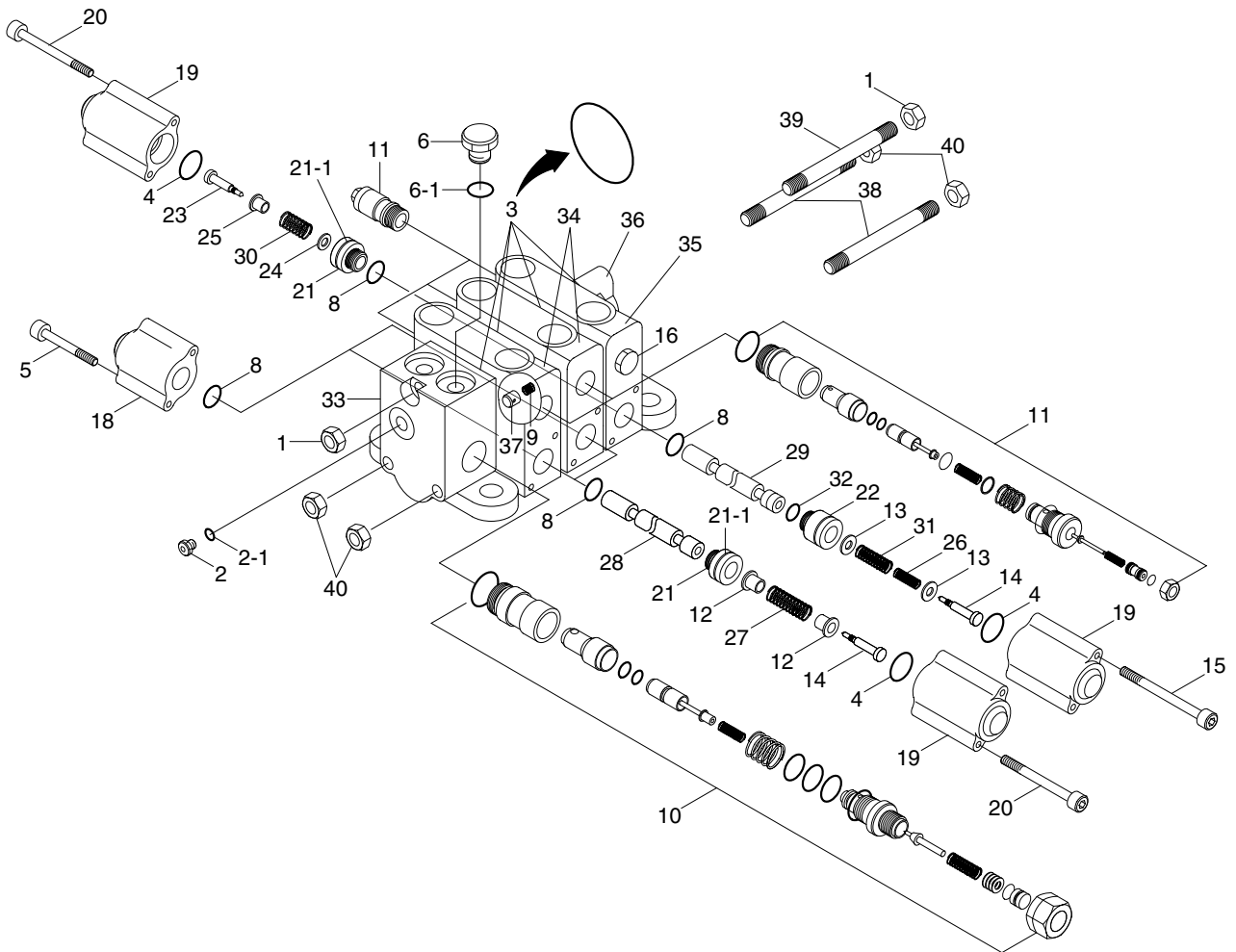

7407B6WE45

1	Nut	14	Screw	28	Spool
2	Plug	15	Screw	29	Spool
2-1	O-ring	16	Anti void assy	30	Spring
3	O-ring	18	Spool cap	31	Spring
4	O-ring	19	Spool cap	32	Back up ring
5	Cap screw	20	Cap screw	33	Inlet section assy
6	Plug	21	Spool retainer	34	Spool section assy
6-1	O-ring	21-1	Back up ring	35	Spool section assy
8	O-ring	22	Spool retainer	36	Outlet section assy
9	Spring	23	Screw	37	Poppet
10	Main relief valve	24	Washer	38	Tie rod
11	Port relief valve	25	Spacer	39	Tie rod
12	Spring seat	26	Spring	40	Nut
13	Washer	27	Spring		



## STRUCTURE

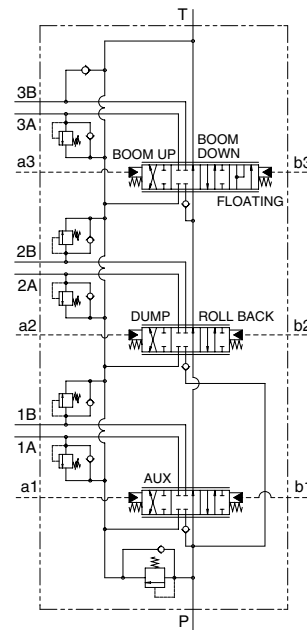
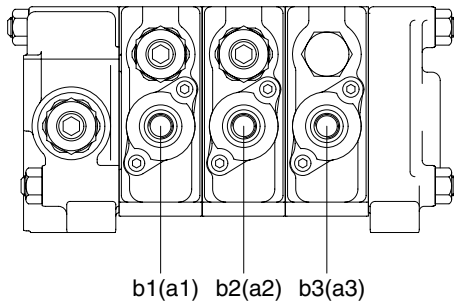
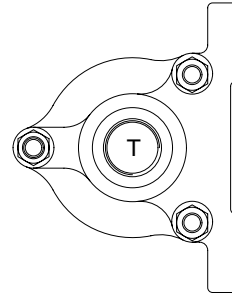
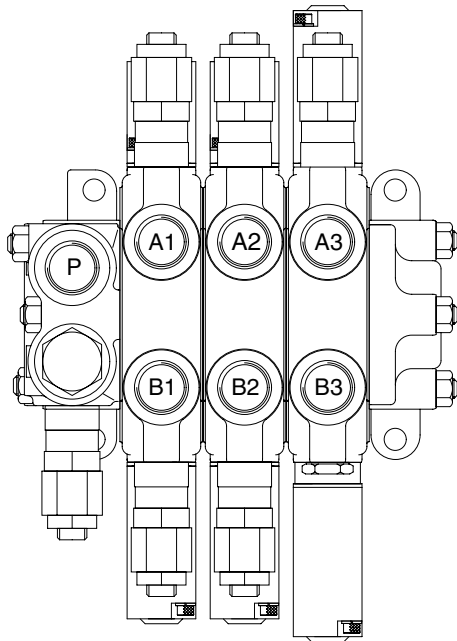

HYDRAULIC CIRCUIT

7407B6WE20

Port	Port name	Port size
P	From main pump	1 3/16 - 12UN
T	To hydraulic tank	1 5/16 - 12UN
A1, B1	To auxiliary cylinder port	1 3/16 - 12UN
A2, B2	To bucket cylinder port	1 3/16 - 12UN
A3, B3	To boom cylinder port	1 3/16 - 12UN
a3, b3	Boom pilot port	9/16 - 18 UNF
a2, b2	Bucket pilot port	9/16 - 18 UNF
a1, b1	Auxiliary pilot port	9/16 - 18 UNF

2) BOOM SECTION OPERATION

(1) Spool in neutral

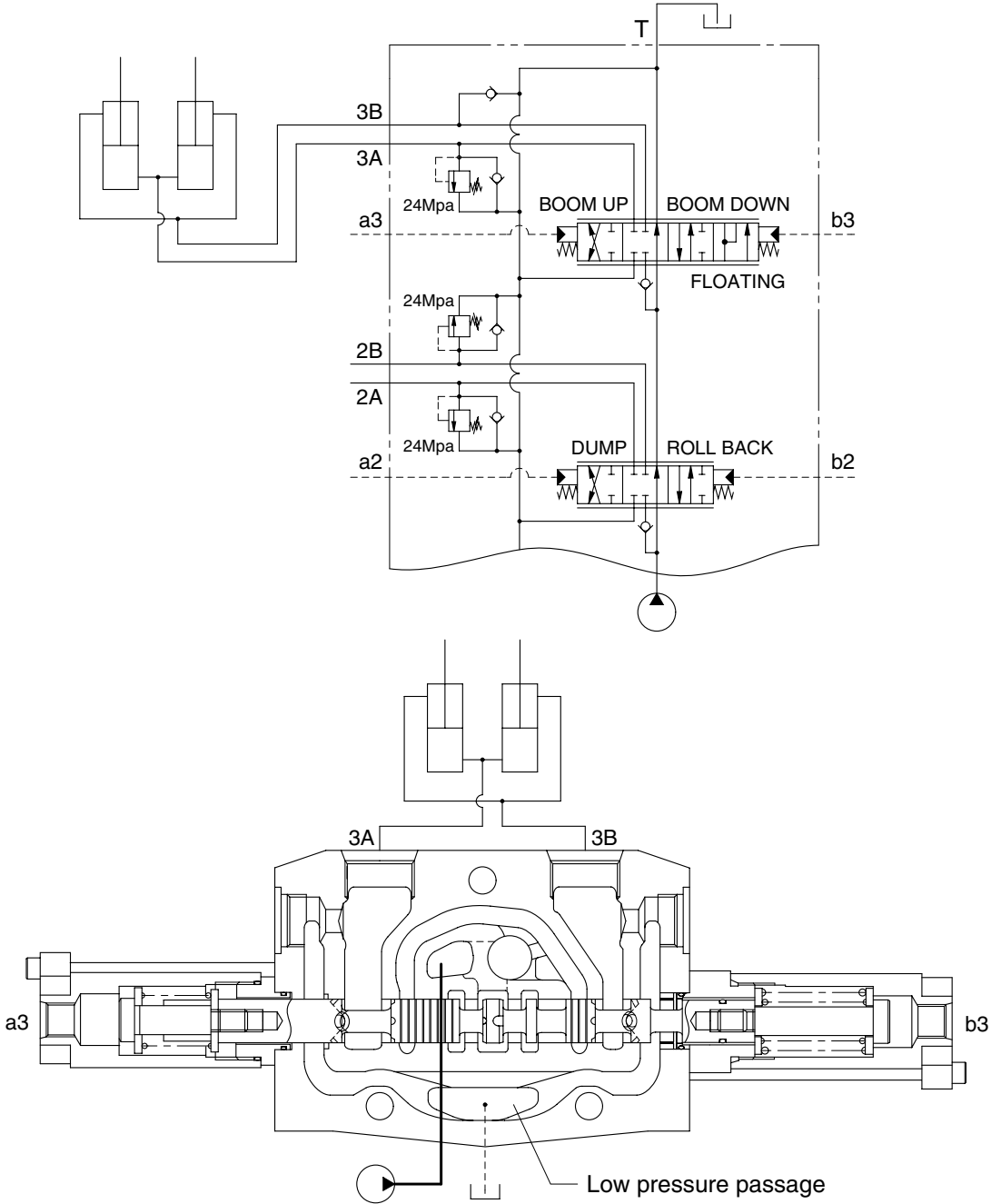

7407B6WE11

If the remote control valve is not operated, the oil supplied from the pump port passes through the neutral passage to the low pressure passage at the outlet section, and then returns to the tank port.

## (2) Boom raise position

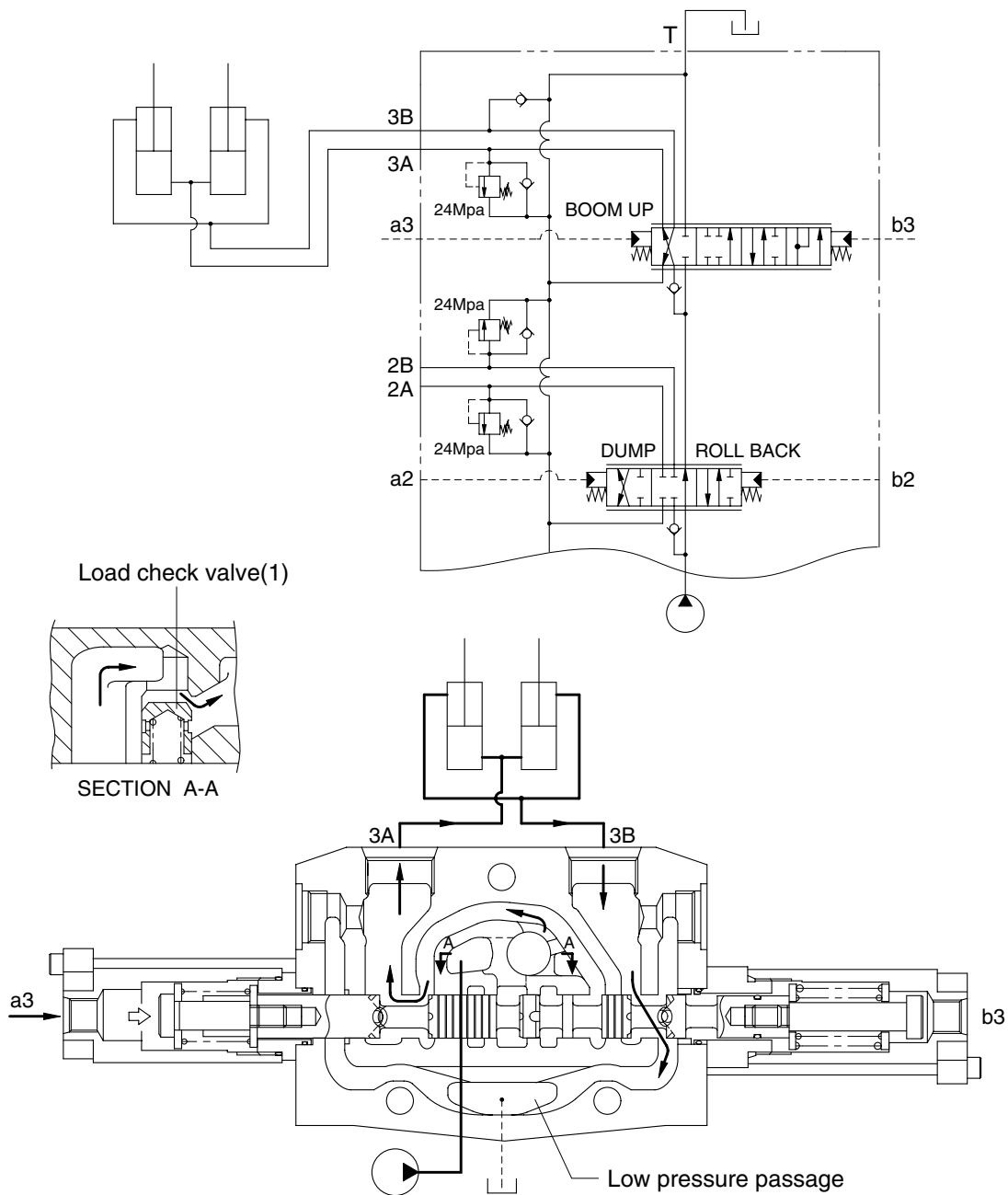

7407B6WE12

When the pilot pressure from remote control valve is supplied to the pilot port (a3), the spool moves to the right and the neutral passage is closed.

The oil supplied from the pump pushes up the load check valve (1) and flow into boom cylinder port (3A).

The pump pressure reaches proportionally the load of cylinder and fine control finished by shut off of the neutral passage.

The return oil from cylinder port (3B) flows into the tank via the low pressure passage.

### (3) Boom lower position

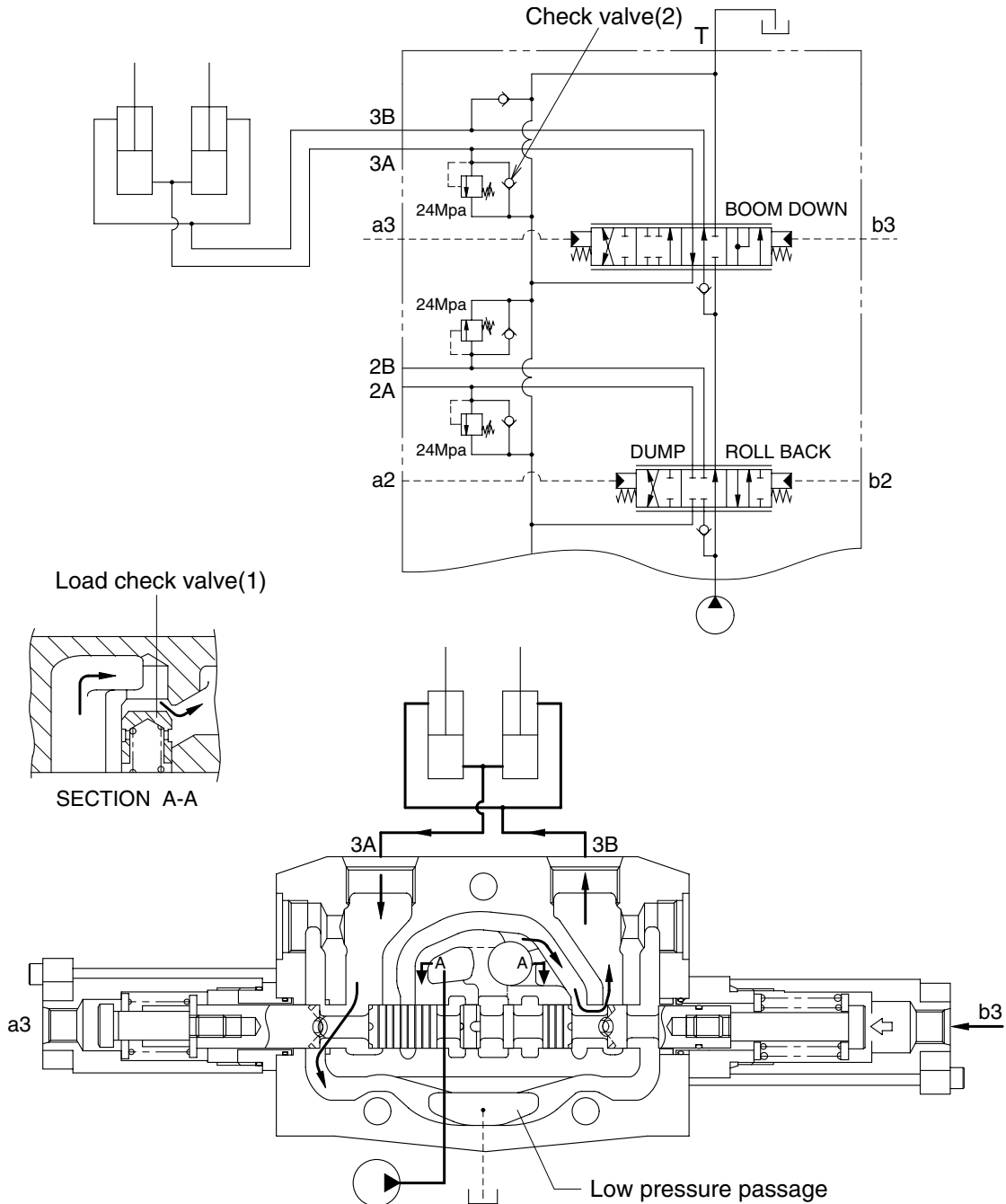

7407B6WE13

When the pilot pressure from remote control valve is supplied to the pilot port (b3), the spool moves to the left and the neutral passage is closed.

The oil supplied from the pump pushes up the load check valve (1) and flow into boom cylinder port (3B). The pump pressure reaches proportionally the load of cylinder and fine control finished by shut off of the neutral passage.

The return oil from cylinder port (3A) flows into the tank via the low pressure passage.

When the lowering speed of boom is faster, the return oil from the large chamber of boom cylinder combines with the oil from the pump through the check valve (2), and flows into the small chamber of cylinder. This prevents cylinder cavitation by the negative pressure when the pump flow cannot match the boom lowering speed.

#### (4) Boom float position

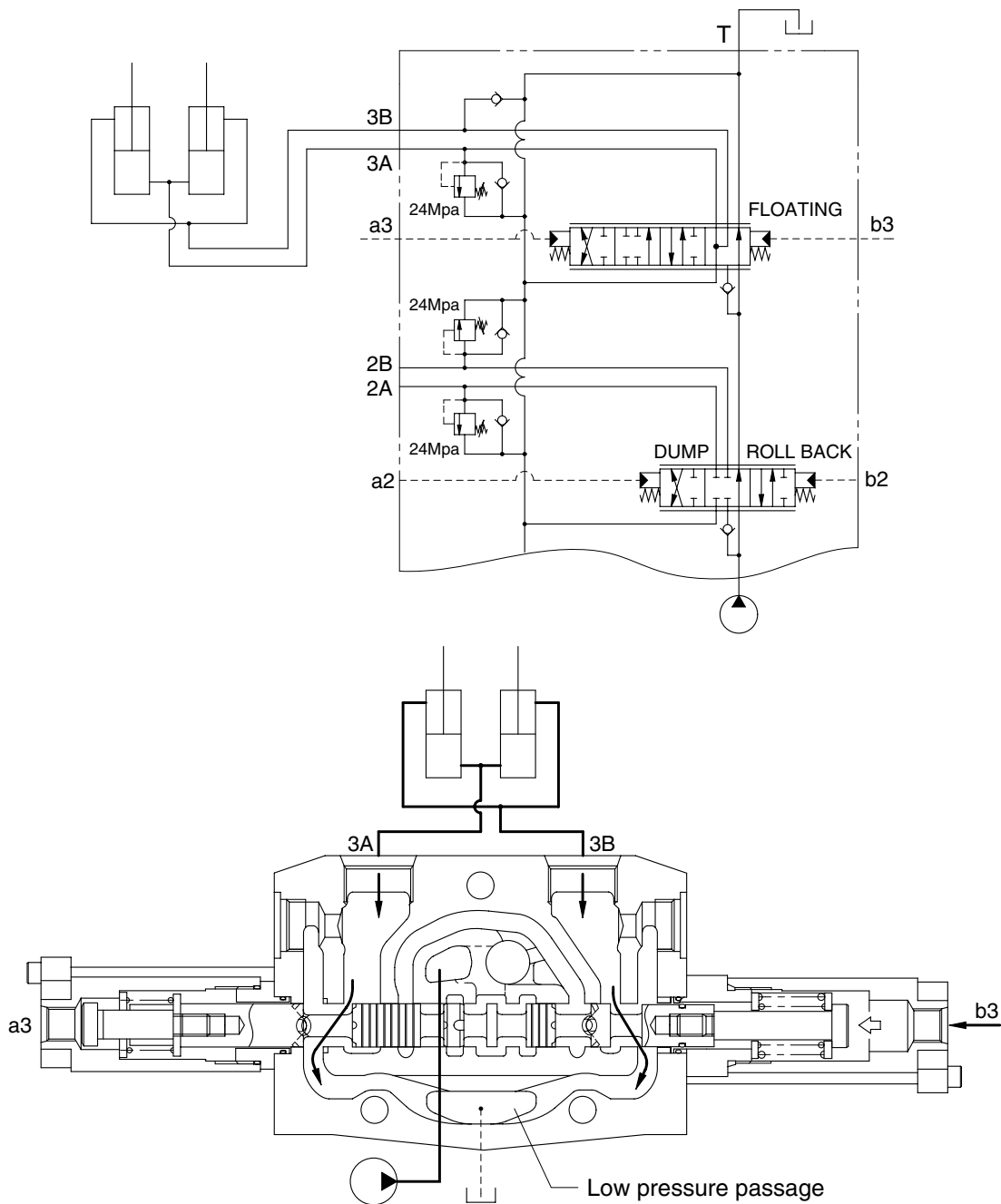

7407B6WE14

If the remote control lever pushes further more, the pilot pressure from remote control valve rises over 13-15bar and then the boom lowering spool is pushed to the boom floating position, opening up the neutral passage to tank and simultaneously (3A), (3B) → T.

In float position the boom drops quickly due to its own weight.

When the bucket touches the ground and the wheeled loader is moving, the bucket raised or lowered following the unevenness of the ground due to the (3A), (3B) → T connecting.

### 3) BUCKET SECTION OPERATION

#### (1) Spool in neutral

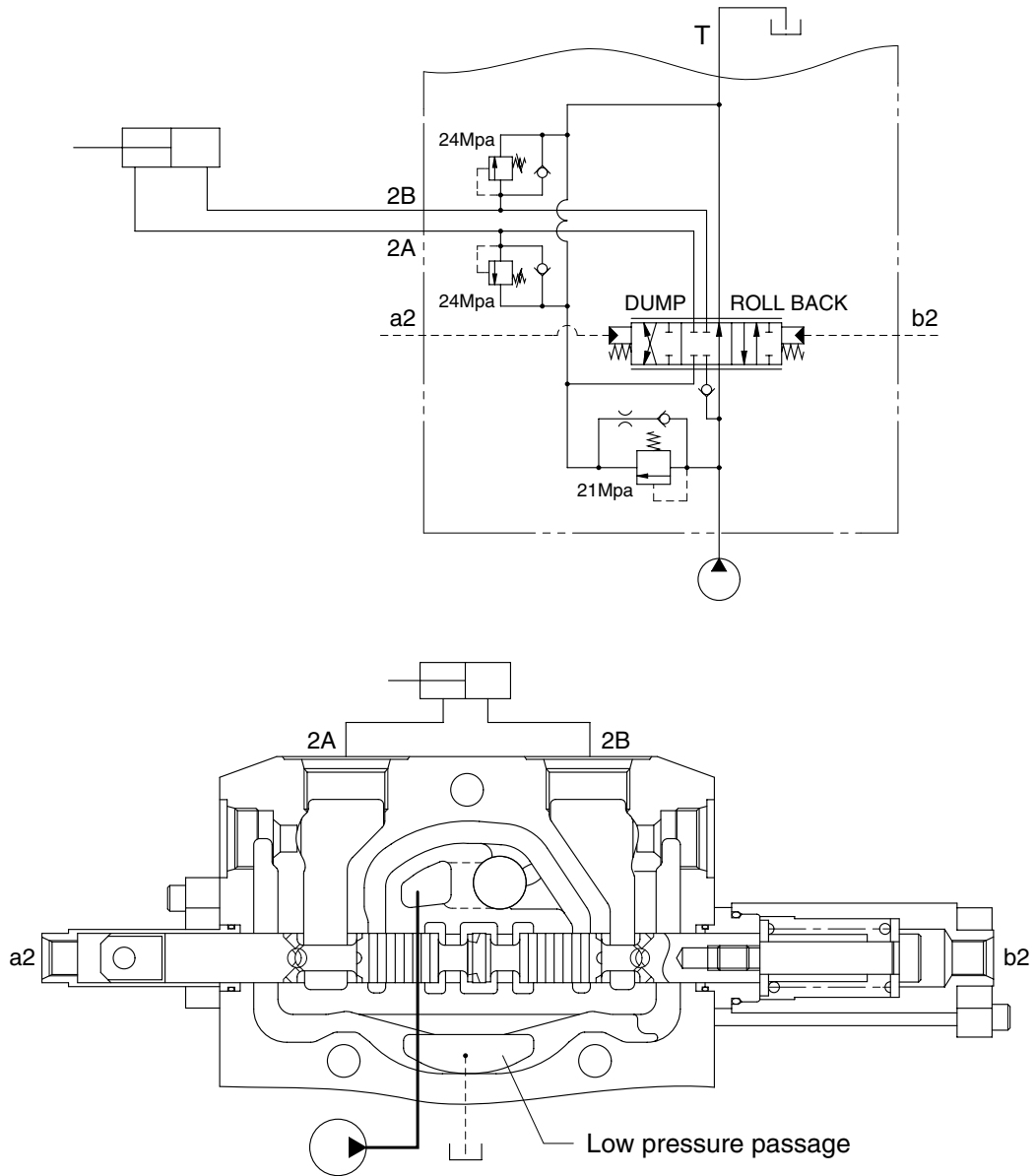

7407B6WE15

If the remote control valve is not operated, the oil supplied from the pump port passage through the neutral passage to the low pressure passage at the outlet section, and then return to the tank port.

**(2) Retract (roll back) position**

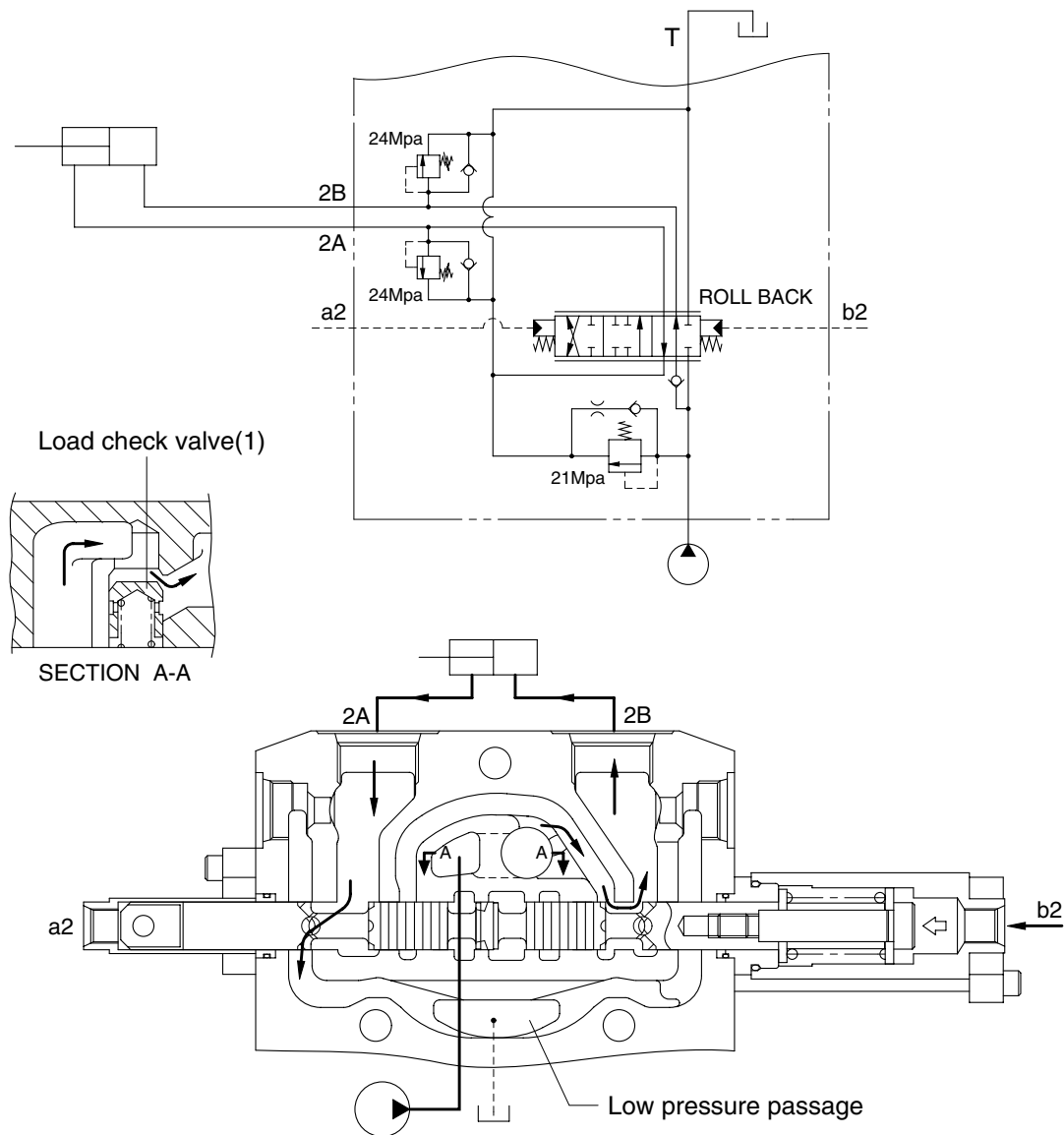

7407B6WE16

When the pilot pressure from remote control valve is supplied to the pilot port (b2), the spool moves to the left and the neutral passage is closed.

The oil supplied from the pump pushes up the load check valve (1) and flow into bucket cylinder port (2B).

The pump pressure reaches proportionally the load of cylinder and fine control finished by shut off of the neutral passage.

The return oil from cylinder port (2A) flows into the tank via the low pressure passage.

### (3) Dump position

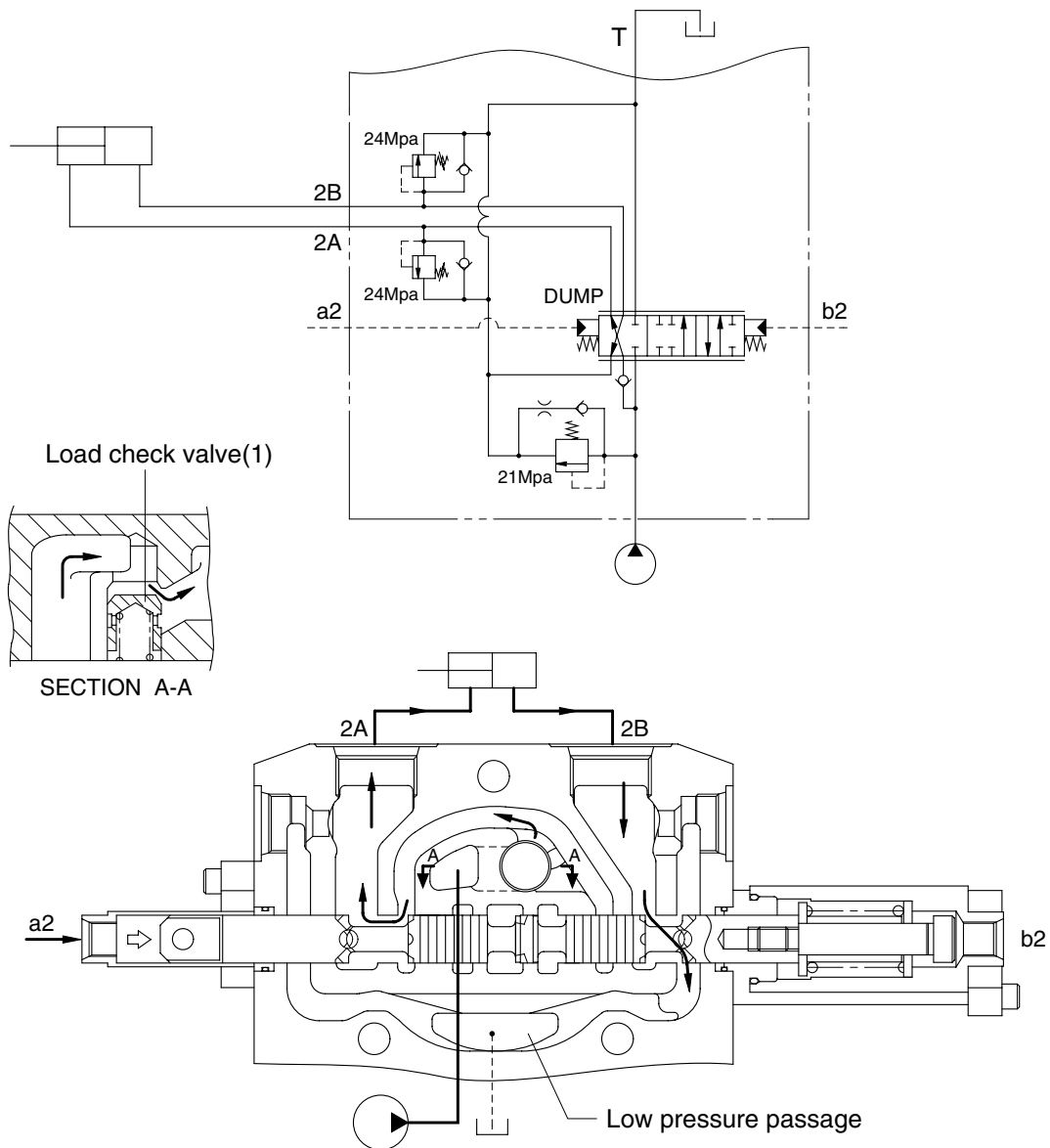

7407B6WE17

When the pilot pressure from remote control valve is supplied to the pilot port (a1), the spool moves to the right and the neutral passage is closed.

The oil supplied from the pump pushes up the load check valve (1) and flow into bucket cylinder port (2A).

The pump pressure reaches proportionally the load of cylinder and fine control finished by shut off of the neutral passage.

The return oil from cylinder port (2B) flows into the tank via the low pressure passage.



#### 4) PRESSURE SETTING

A good pressure gage must be installed in the line which is in communication with the work port relief. A load must be applied in a manner to reach the set pressure of the relief unit.

##### (1) Main relief valve

- ① Loosen lock nut.
- ② Set adjusting nut to desired pressure setting.
- ③ If desired pressure setting cannot be achieved, add or remove shims as required.
- ④ Tighten lock nut.
- ⑤ Retest in similar manner as above.

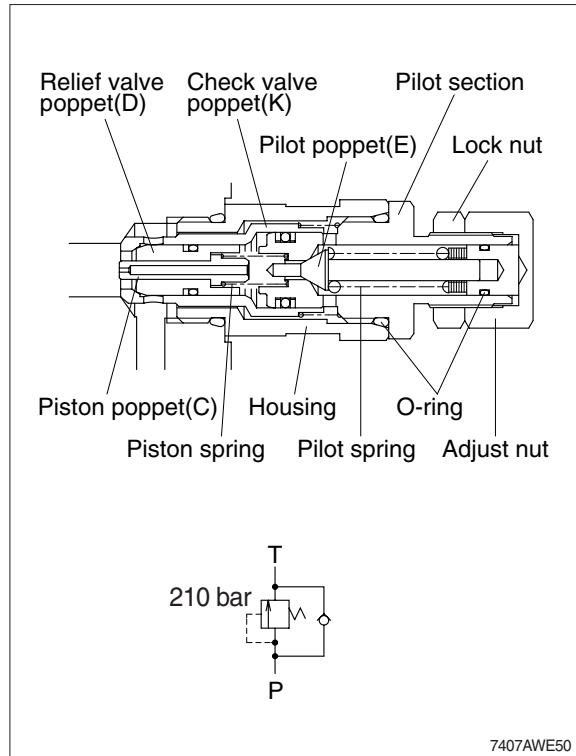

##### (2) Port relief valve

- ① Loosen lock nut.
- ② Set adjusting screw to desired pressure setting.
- ③ Tighten lock nut.
- ④ Retest in similar manner as above.

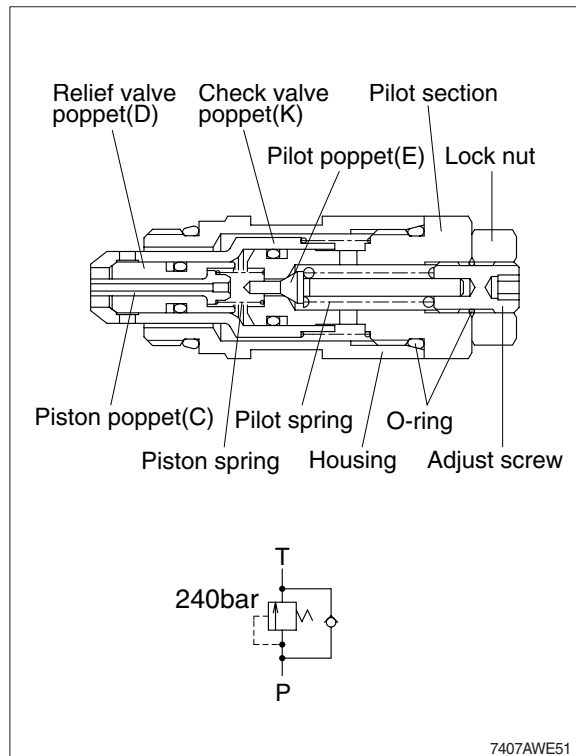

## 5) MAIN RELIEF VALVE

### (1) As relief

The relief valve is in communication between the high pressure port HP and low pressure LP. Oil is admitted through the hole in poppet C and because of the differential area between diameters A and B relief valve poppet D and check valve poppet K are tightly seated as shown in the first step.

The oil pressure in the high pressure port Hp has reached the setting of the pilot poppet spring force and unseats the pilot poppet E and oil flows around the poppet through the cross drilled holes and to the low pressure area LP.

The loss of oil behind poppet C, effected by the opening of pilot poppet E, causes poppet C to move back and seat against pilot poppet E. This shuts off the oil flow to the area behind relief valve poppet D, and causes a low pressure area internally.

The imbalance of pressure on the inside as compared to that of the high pressure port HP, forces the relief valve poppet D to open and relieve the oil directly to the low pressure chamber LP in the valve.

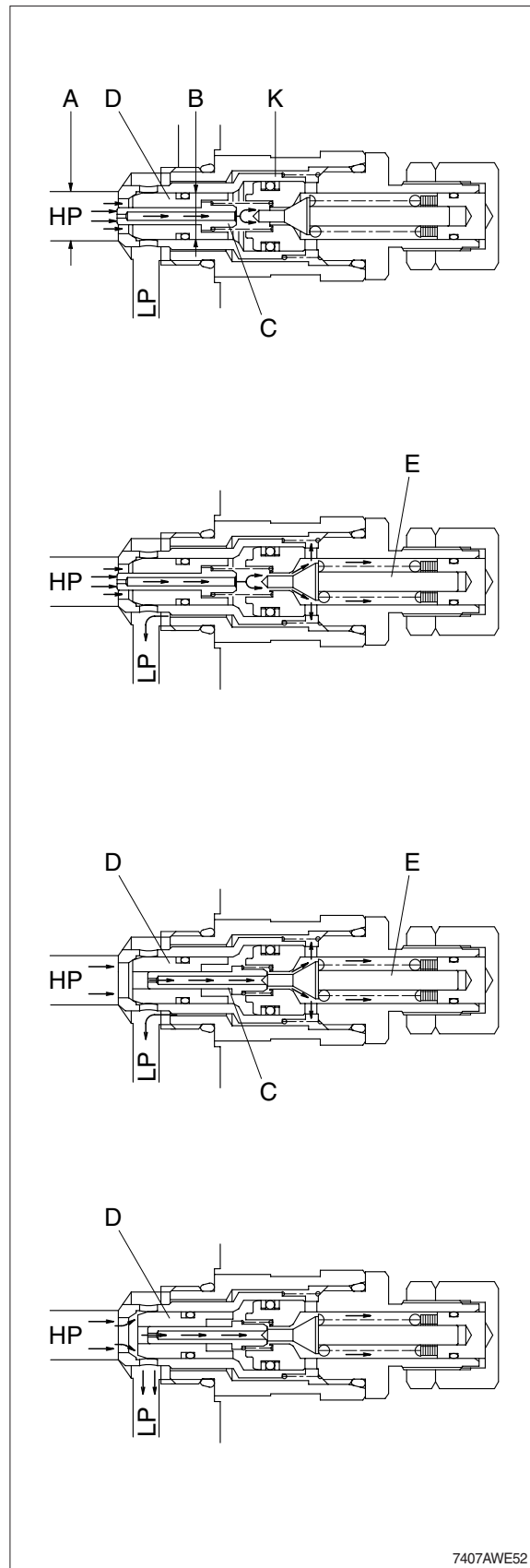

7407AWE52

### (2) As anti void

The anti-void unit supplies oil to the high pressure port HP when cavitation has occurred. A lower pressure exists in the port HP compared to the low pressure chamber LP. The difference between the effective area of diameter A and G causes imbalance of the check valve poppet K which unseats, thus allowing oil from the low pressure chamber LP to enter the port HP and fill the void.

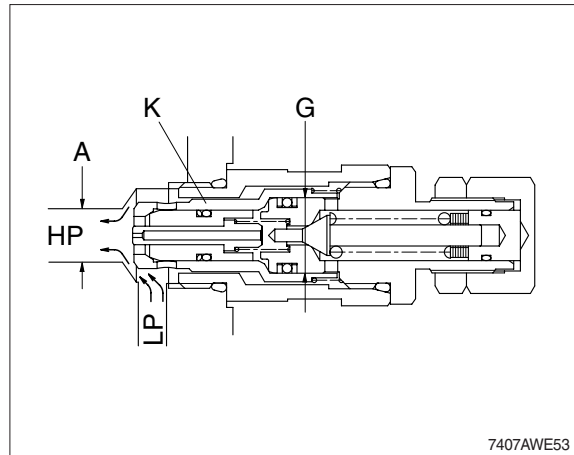

### (3) As separate anti void

The anti-void check valve opens when cavitation occurs in the high pressure port HP and supplies oil from the reservoir LP to help fill this void. The poppet M is held on its seat by the port pressure HP, acting on the larger area behind the O-ring. When pressure HP drops below atmosphere, the tank pressure LP operating on the annular area A1-A2 will overcome the port pressure HP and the spring force to open the poppet. When the void is eliminated the spring will return the poppet which will then be tightly seated by the port pressure HP.

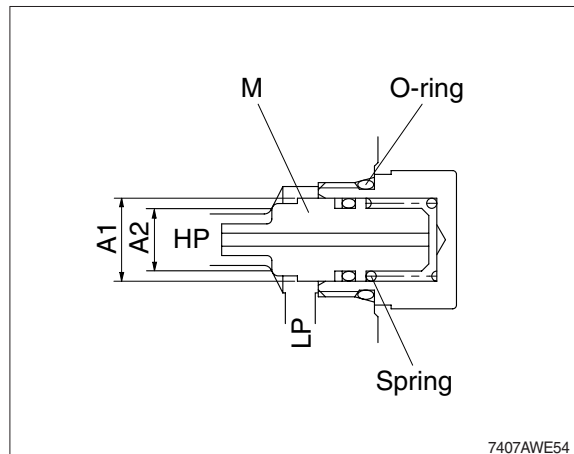

## 6) PORT RELIEF VALVE

### (1) As relief

The relief valve is in communication between the high pressure port HP and low pressure LP. Oil is admitted through the hole in poppet C and because of the differential area between diameters A and B relief valve poppet D and check valve poppet K are tightly seated as shown in the first step.

The oil pressure in the high pressure port HP has reached the setting of the pilot poppet spring force and unseats the pilot poppet E and oil flows around the poppet through the cross drilled holes and to the low pressure area LP.

The loss of oil behind poppet C, effected by the opening of pilot poppet E, causes poppet C to move back and seat against pilot poppet E. This shuts off the oil flow to the area behind relief valve poppet D, and causes a low pressure area internally.

The imbalance of pressure on the inside as compared to that of the high pressure port HP, forces the relief valve poppet D to open and relieve the oil directly to the low pressure chamber LP in the valve.

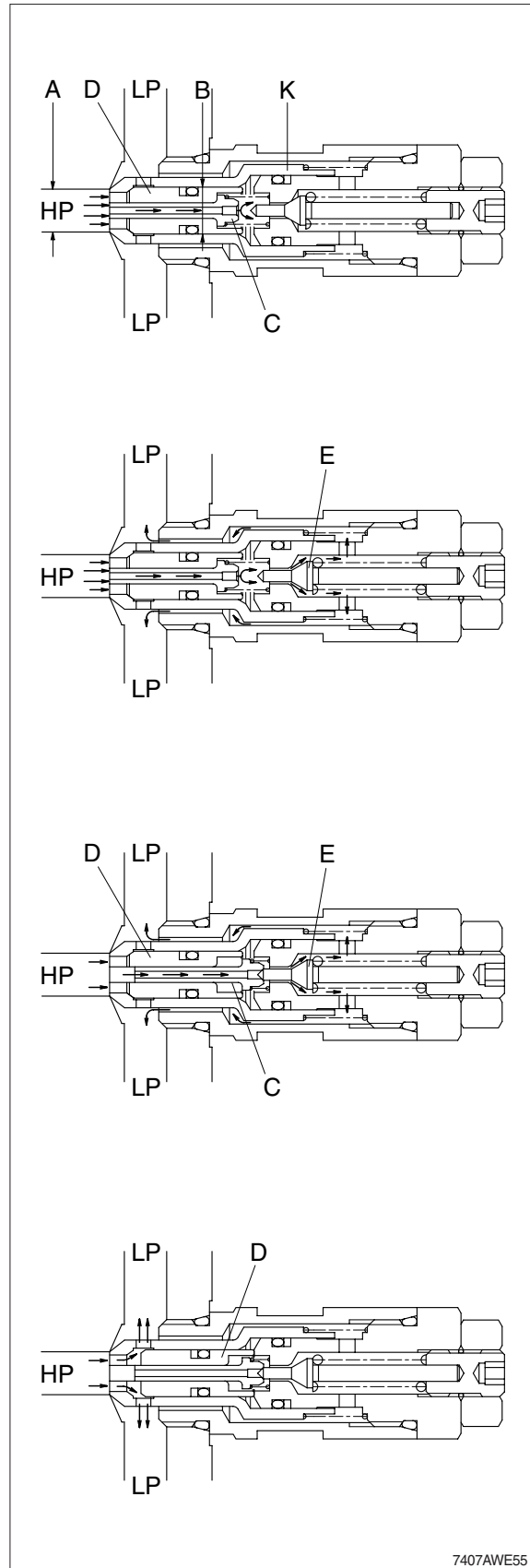

## 7. PILOT OIL SUPPLY UNIT

### 1) STRUCTURE

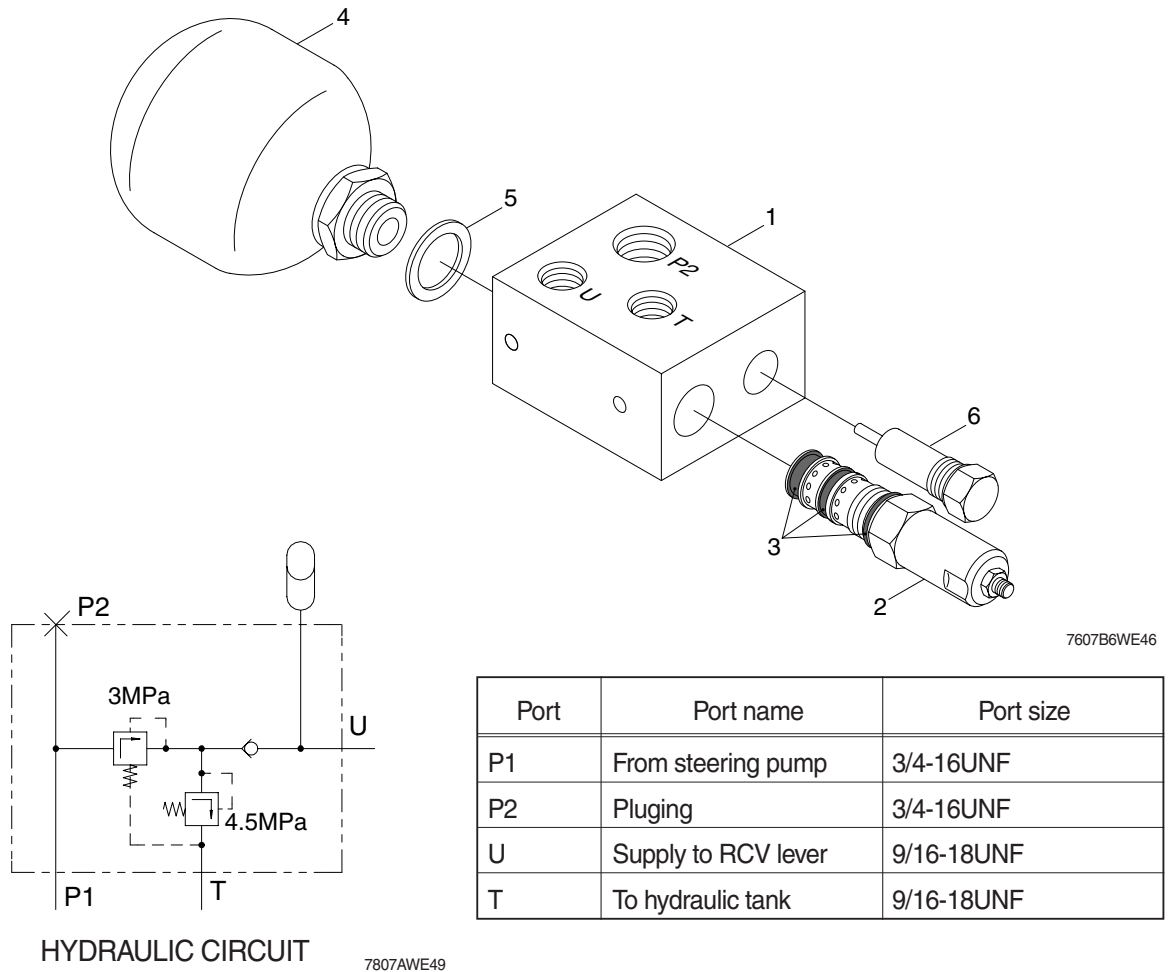

- |   |                   |   |              |
|---|-------------------|---|--------------|
| 1 | Manifold complete | 4 | Accumulator  |
| 2 | Reducing valve    | 5 | Gasket       |
| 3 | Seal kit          | 6 | Relief valve |

### 2) OPERATION

The pilot supply manifold reduces the pressure from the high pressure circuit to a low pressure circuit in order to supply the remote control valve.

The accumulator satisfies short term peak power demands and is a source of emergency power in case of main circuit pressure failures.

The unit consists of the housing, the accumulator(4), the relief valve (6), the check valve and the reducing valve (2).

The flow path is from the high pressure circuit through port P2 to the pressure reducing valve (2).

The pressure is reduced in the reducing valve (2) and oil passes the check valve into the accumulator (4) and to the port U, which is connected with the remote control valve.

The pressure relief valve (6) protects the pilot circuit in case of the reducing valve (2) failures or external increase of pressure.

## 8. BOOM AND BUCKET CYLINDER

The boom cylinders are two unit and the bucket cylinder is one unit. They use a bolt on rod guide.

The piston (12) threads on to the rod (2) and is retained by a nut (18).

The piston seals against the tube (1) with piston seal (15). Two wear rings (16) are located on each side of the piston seal.

The gland(3, the rod guide) seals against the tube with an O-ring (10). The cylinder thread seals against the rod with a lip type buffer ring (7) and a rod seal (5). A dust wiper (8) cleans the rod when it is retracted.

### 1) BOOM CYLINDER

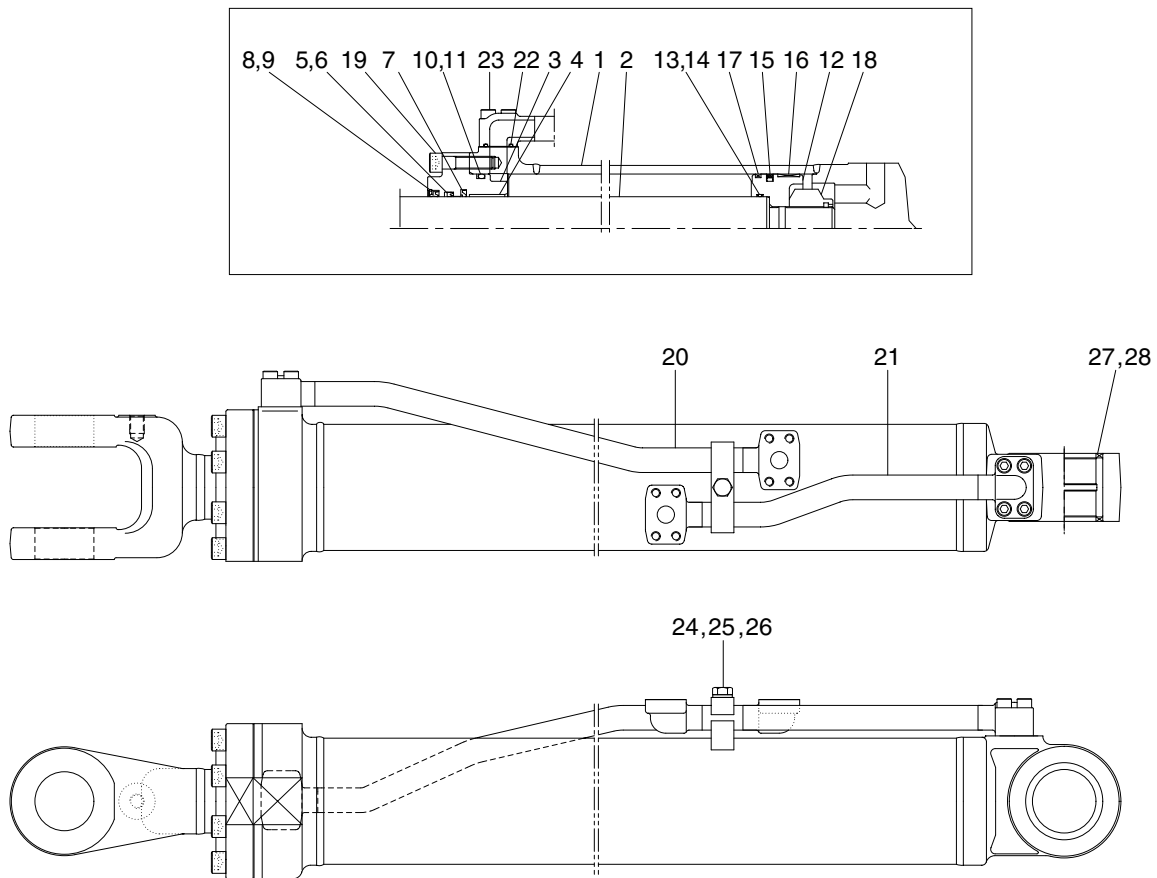

7309S6WE46

1	Tube assembly	11	Back up ring	21	Pipe assembly
2	Rod assembly	12	Piston	22	O-ring
3	Gland	13	O-ring	23	Bolt
4	Bushing	14	Back up ring	24	Clamp
5	Rod seal	15	Piston seal	25	Bolt
6	Back up ring	16	Wear ring	26	Spring washer
7	Buffer ring	17	Dust ring	27	Pin bushing
8	Dust wiper	18	Lock nut	28	Dust seal
9	Snap ring	19	Bolt		
10	O-ring	20	Pipe assembly		

## 2) BUCKET CYLINDER

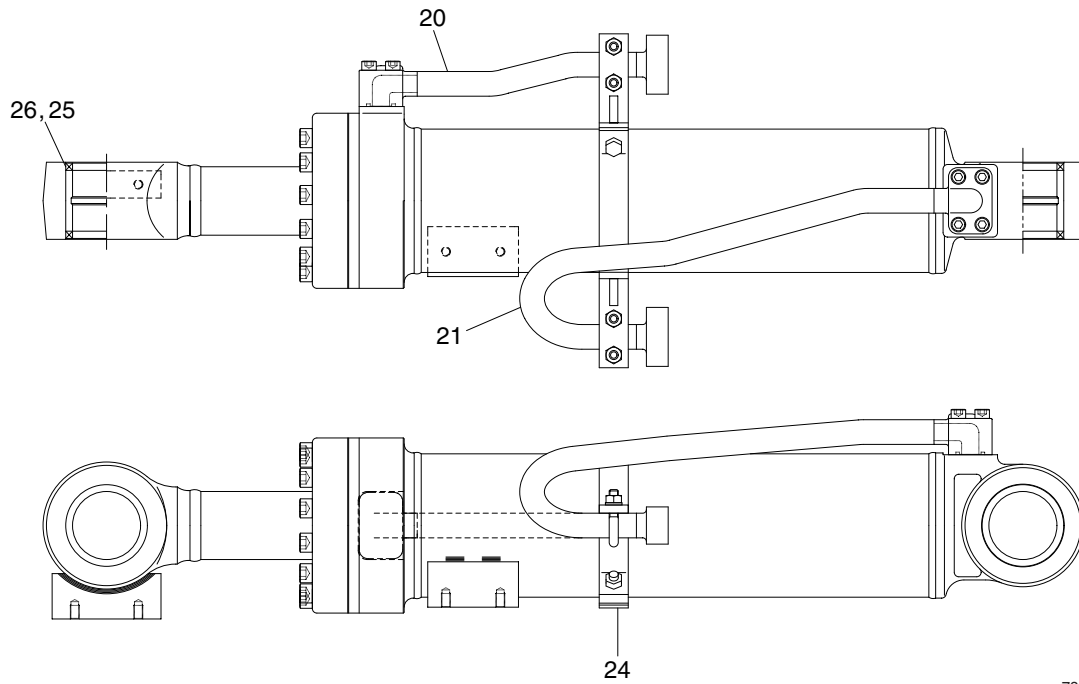
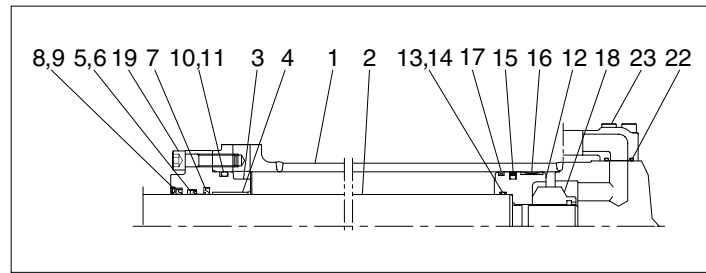

7309S6WE47

- |   |               |    |              |    |               |
|---|---------------|----|--------------|----|---------------|
| 1 | Tube assembly | 10 | O-ring       | 19 | Bolt          |
| 2 | Rod assembly  | 11 | Back up ring | 20 | Pipe assembly |
| 3 | Gland         | 12 | Piston       | 21 | Pipe assembly |
| 4 | Bushing       | 13 | O-ring       | 22 | O-ring        |
| 5 | Rod seal      | 14 | Back up ring | 23 | Bolt          |
| 6 | Back up ring  | 15 | Piston seal  | 24 | Band assembly |
| 7 | Buffer ring   | 16 | Wear ring    | 25 | Pin bushing   |
| 8 | Dust wiper    | 17 | Dust ring    | 26 | Dust seal     |
| 9 | Snap ring     | 18 | Lock nut     |    |               |

## 9. HYDRAULIC OIL TANK

### 1) STRUCTURE

- The oil from the hydraulic tank is sent from the pump through main control valve to the cylinders. In the return circuit, the oil from various parts merges.
- A part of oil is cooled in the oil cooler, passes through the hydraulic filter and returns to the hydraulic tank (1).
- If the hydraulic return oil filter becomes clogged, return filter bypass valve (6) acts to allow the oil to return directly to the hydraulic tank (1). This prevents damage to the hydraulic filter (7). The bypass valve (6) is also actuated when negative pressure is generated in the circuit.

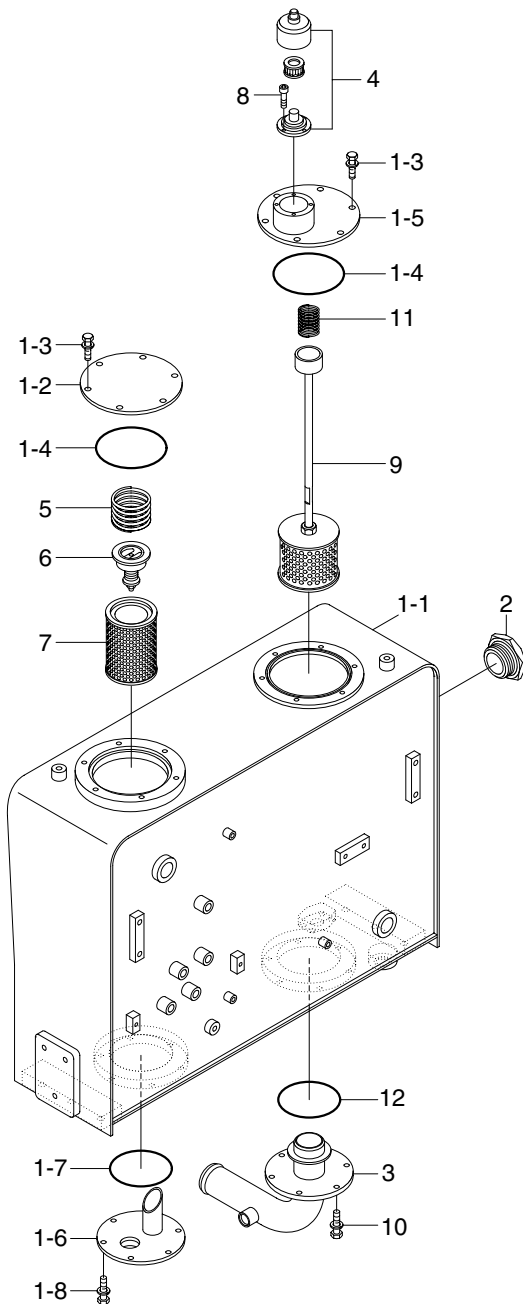

- 1 Hydraulic tank sub assy
- 1-1 Hydraulic tank
- 1-2 Cover
- 1-3 Bolt
- 1-4 O-ring
- 1-5 Suction cover
- 1-6 Cover
- 1-7 O-ring
- 1-8 Bolt
- 2 Sight gauge
- 3 Suction pipe assy
- 4 Air breather
- 5 Spring
- 6 Bypass valve
- 7 Element assy
- 8 Socket bolt
- 9 Strainer assy
- 10 Bolt
- 11 Spring
- 12 O-ring



## 2) RETURN OIL FILTER BYPASS VALVE

### (1) When the filter is clogged

Bypass valve (1) is opened and the oil returns directly to the tank without passing through the filter.

- Bypass valve set pressure : 1.36kgf/cm<sup>2</sup>  
(19.3psi)

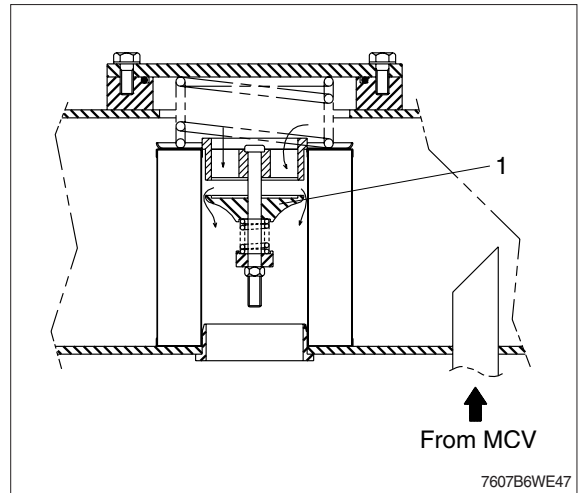

### 3) AIR BREATHER

The air breather is equipped with the capacity to perform three functions simultaneously-as an air filter, breathing valve, and as a lubrication opening.

#### (1) Preventing negative pressure inside the tank

The tank is a pressurized sealed type, so negative pressure is formed inside the hydraulic tank when the oil level drops during operations. When this happens, the difference in pressure between the tank and the outside atmospheric pressure opens the poppet in the breather, and air from the outside is let into the tank or prevent negative pressure.

#### (2) Preventing excessive pressure inside the tank

When the hydraulic cylinder is being used, the oil level in the hydraulic system increases and as temperature rises. If the hydraulic pressure rises above the set pressure, breather is actuated to release the hydraulic pressure inside the tank.

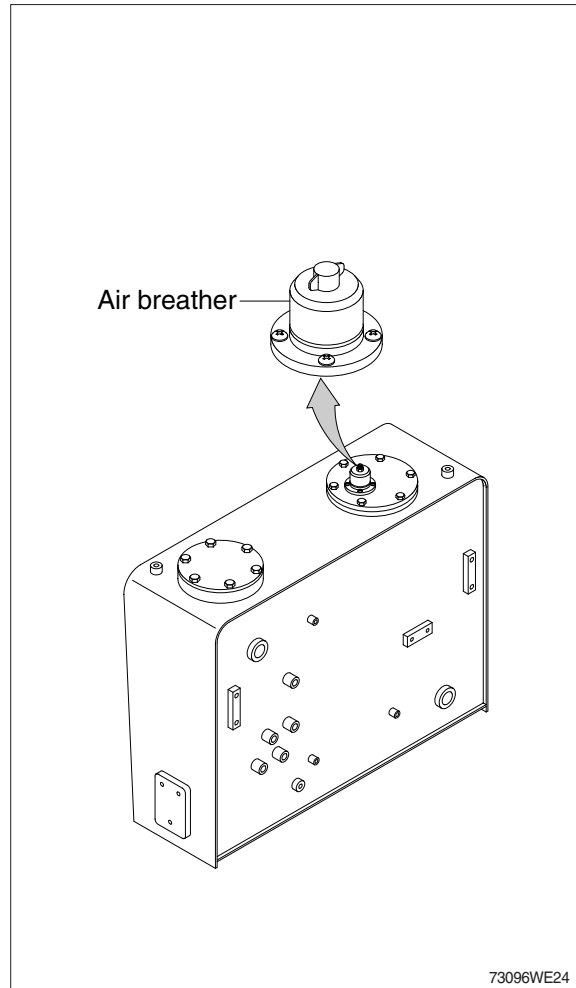

## 10. ACCUMULATOR

The accumulator is installed at the pilot oil supply unit. When the boom is left the raised position, and the control levers are operated with the engine stopped the pressure of the compressed nitrogen gas inside the accumulator sends pilot pressure to the control valve to actuate it and allow the boom and bucket to come down under their own weight.

Type of gas	Nitrogen gas (N <sub>2</sub> )
Volume of gas	0.75 l (0.2 U.S.gal)
Charging pressure of gas	16 kg/cm <sup>2</sup> (228 psi)
Max actuating pressure	128 kg/cm <sup>2</sup> (1820 psi)

