

## SECTION 6 WORK EQUIPMENT

### GROUP 1 STRUCTURE AND FUNCTION

#### 1. HYDRAULIC SYSTEM OUTLINE

The loader hydraulic system is a pilot operated, open center system which is supplied with flow from the fixed displacement main hydraulic pump.

The pilot control system is a low pressure, closed center hydraulic system which is supplied with flow from the first(Steering) pump.

The loader system components are :

- Main pump
- Main control valve
- Bucket cylinder
- Boom cylinders
- Pilot supply unit
- Remote control valve(Pilot control valve)
- Safety valve

The pilot supply unit consists of the pressure reducing valve, relief valve and accumulator.

Flow from the main hydraulic pump not used by the steering system leaves the priority valve EF port. It flows to the inlet port plate of four blocks type main control valve.

The main control valve is a tandem version spool type, open center valve which routes flow to the boom, bucket or auxiliary cylinders(Not shown) when the respective spools are shifted.

Flow from the steering pump(The first pump) is routed to the pilot supply unit where the steering pump outlet pressure is reduced to pilot circuit pressure. The pilot supply unit flow to the remote control valve.

The remote control valve routed flow to either end of each spool valve section in the main control valve to control spool stroke.

A accumulator mounted on pilot supply unit supplies a secondary pressure source to operated remote control valve so the boom can be lowered if the engine is off.

The return circuit for the main hydraulic system have return filter inside the hydraulic tank. The return filter uses a filter element and a bypass valve. The bypass valve is located in the upside of filter.

## 2. HYDRAULIC CIRCUIT

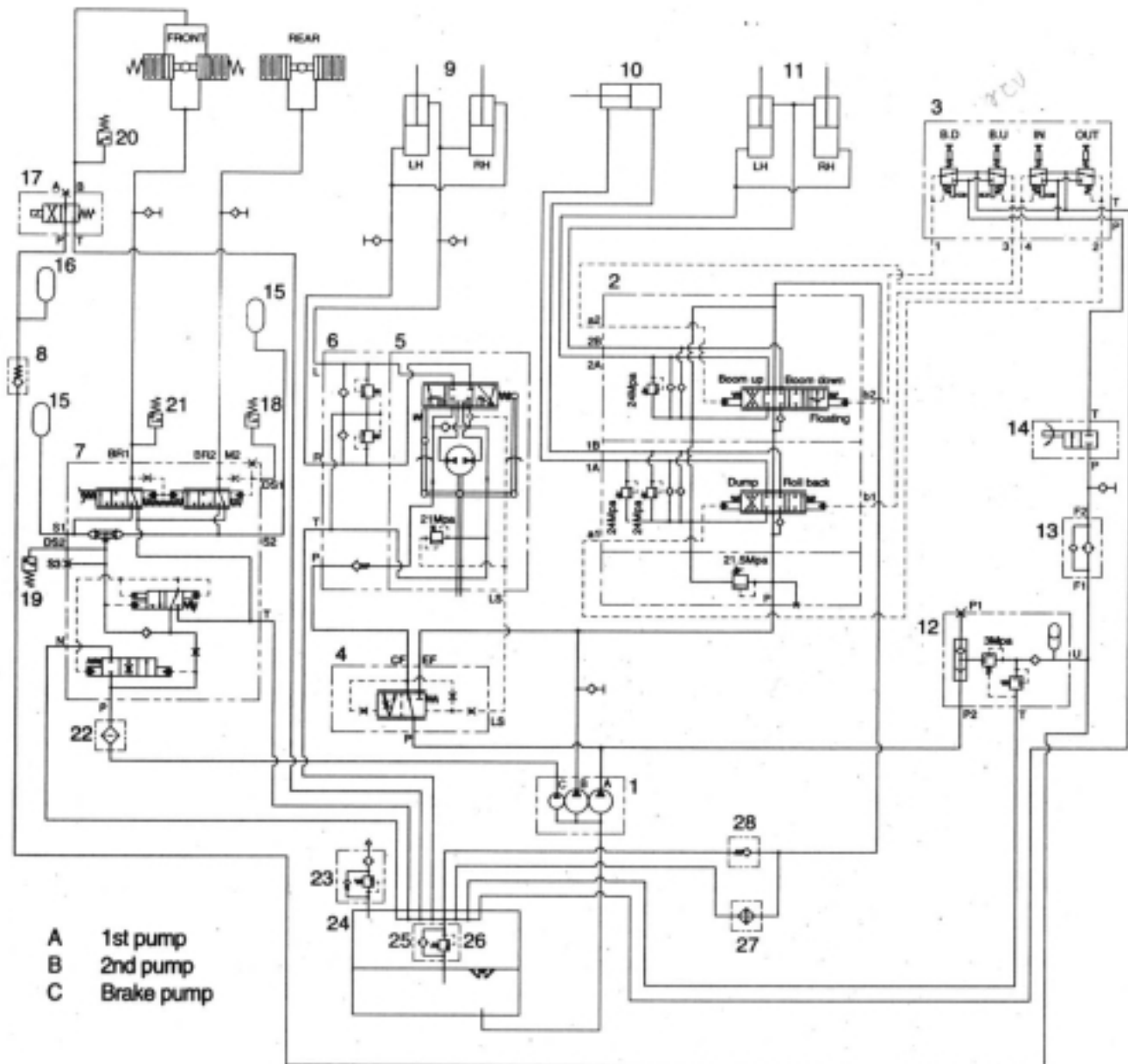

- A 1st pump
- B 2nd pump
- C Brake pump

- |    |                      |    |                   |    |                       |
|----|----------------------|----|-------------------|----|-----------------------|
| 1  | Pump assy            | 11 | Boom cylinder     | 21 | Pressure switch       |
| 2  | Main control valve   | 12 | Pilot supply unit | 22 | Line filter           |
| 3  | Remote control valve | 13 | Line filter       | 23 | Air breather          |
| 4  | Priority valve       | 14 | Safety valve      | 24 | Hydraulic tank        |
| 5  | Steering unit        | 15 | Accumulator       | 25 | Return filter         |
| 6  | Valve block          | 16 | Accumulator       | 26 | By pass valve         |
| 7  | Brake valve          | 17 | Solenoid valve    | 27 | Oil cooler(Optional)  |
| 8  | Check valve          | 18 | Pressure switch   | 28 | Check valve(Optional) |
| 9  | Steering cylinder    | 19 | Pressure switch   |    |                       |
| 10 | Bucket cylinder      | 20 | Pressure switch   |    |                       |

### 3. WORK EQUIPMENT HYDRAULIC CIRCUIT

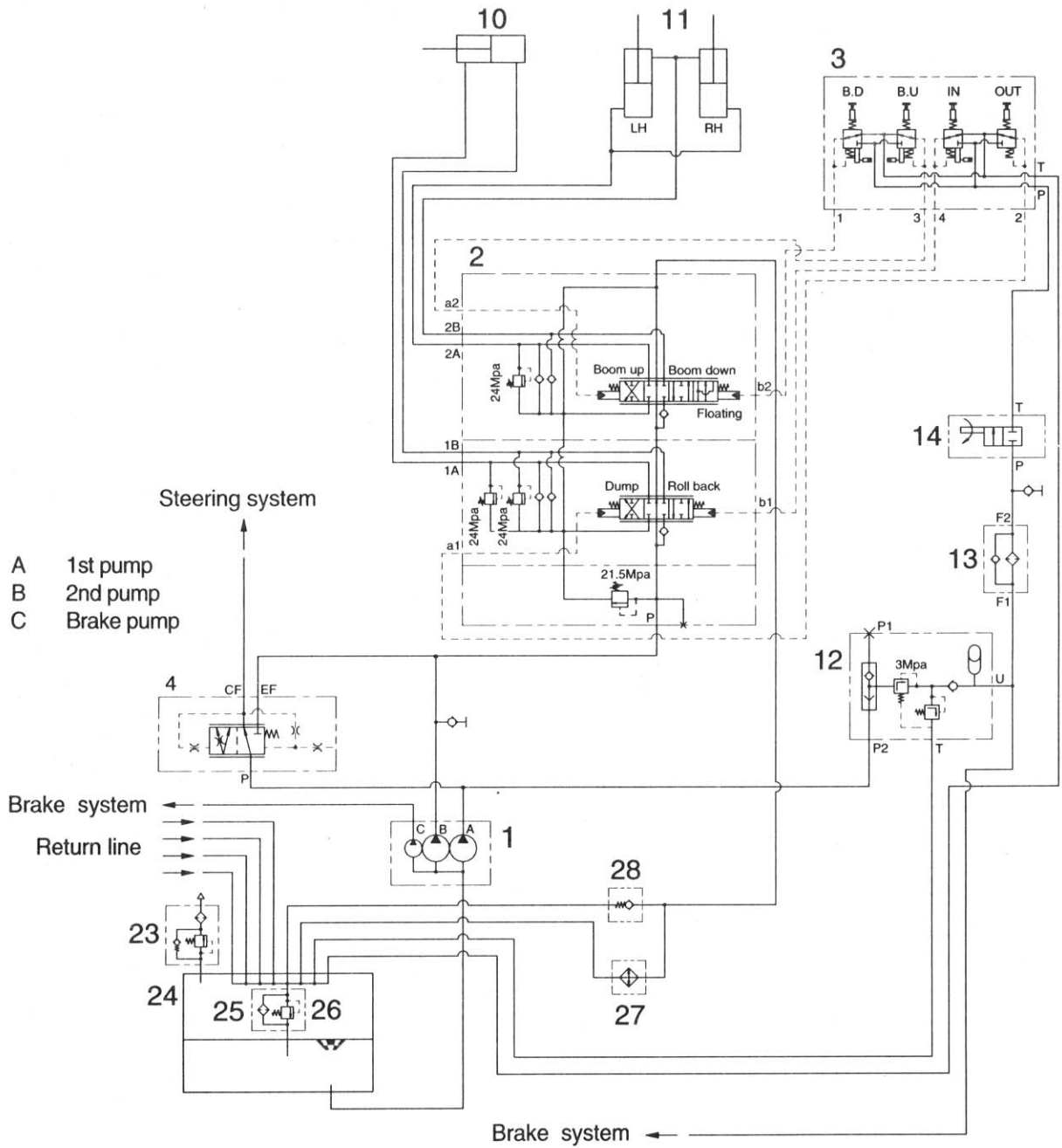

- |    |                      |    |                   |    |                       |
|----|----------------------|----|-------------------|----|-----------------------|
| 1  | Pump assy            | 12 | Pilot supply unit | 25 | Return filter         |
| 2  | Main control valve   | 13 | Line filter       | 26 | By pass valve         |
| 3  | Remote control valve | 14 | Safety valve      | 27 | Oil cooler(Optional)  |
| 10 | Bucket cylinder      | 23 | Air breather      | 28 | Check valve(Optional) |
| 11 | Boom cylinder        | 24 | Hydraulic tank    |    |                       |

1) WHEN THE RCV LEVER IS IN THE RAISE POSITION

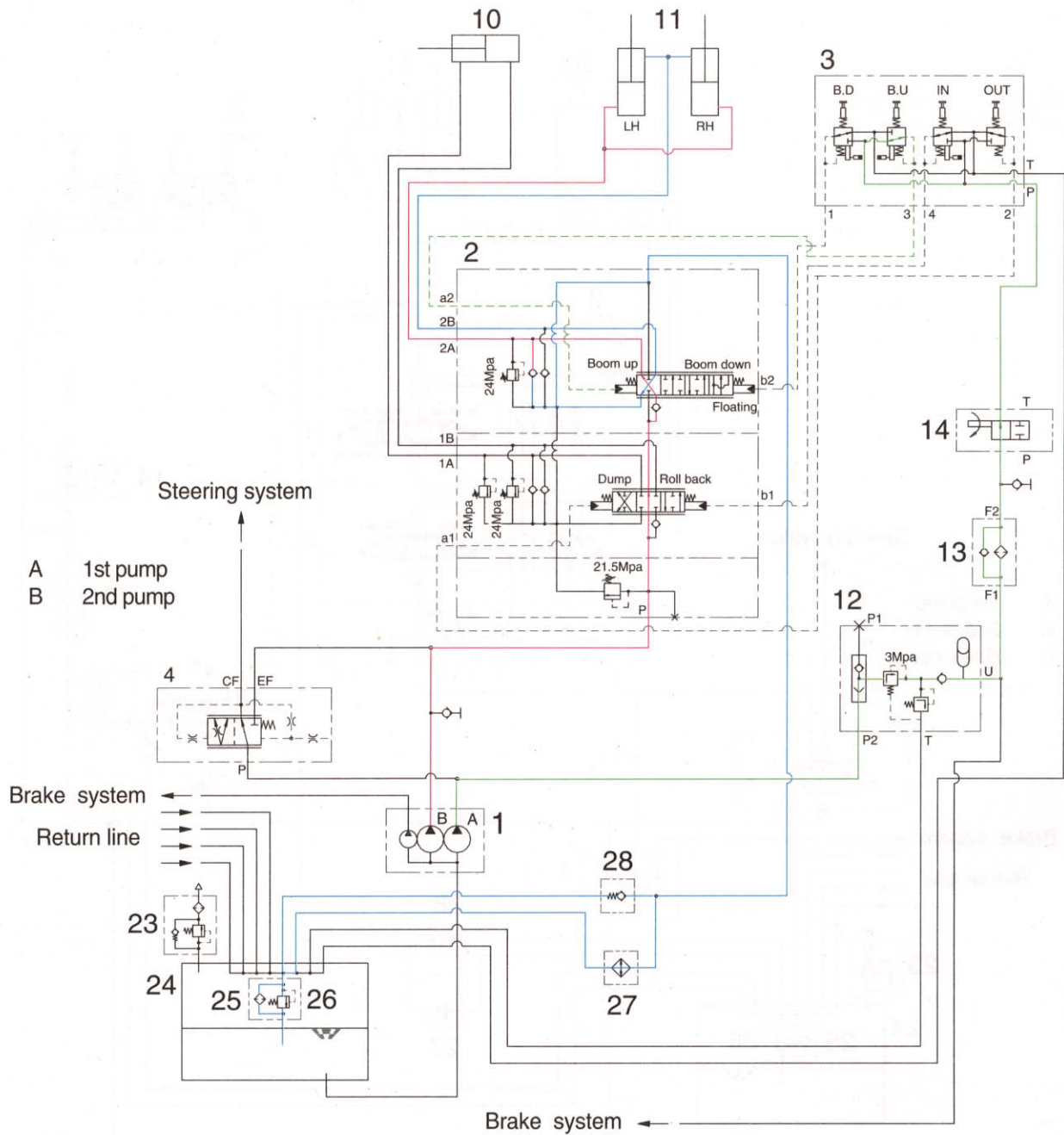

- When the RCV lever(3) is pulled back, the boom spool on the second block is moved to raise position by pilot oil pressure from port 3 of RCV.
- The oil from main pump(1) flows into main control valve(2) and then goes to the large chamber of boom cylinder (11) by pushing the load check valve of the boom spool through center bypass circuit of the bucket spool.
- The oil from the small chamber of boom cylinder(11) returns to hydraulic oil tank(24) through the boom spool at the same time.
- When this happens, the boom goes up.

## 2) WHEN THE RCV LEVER IS IN THE LOWER POSITION

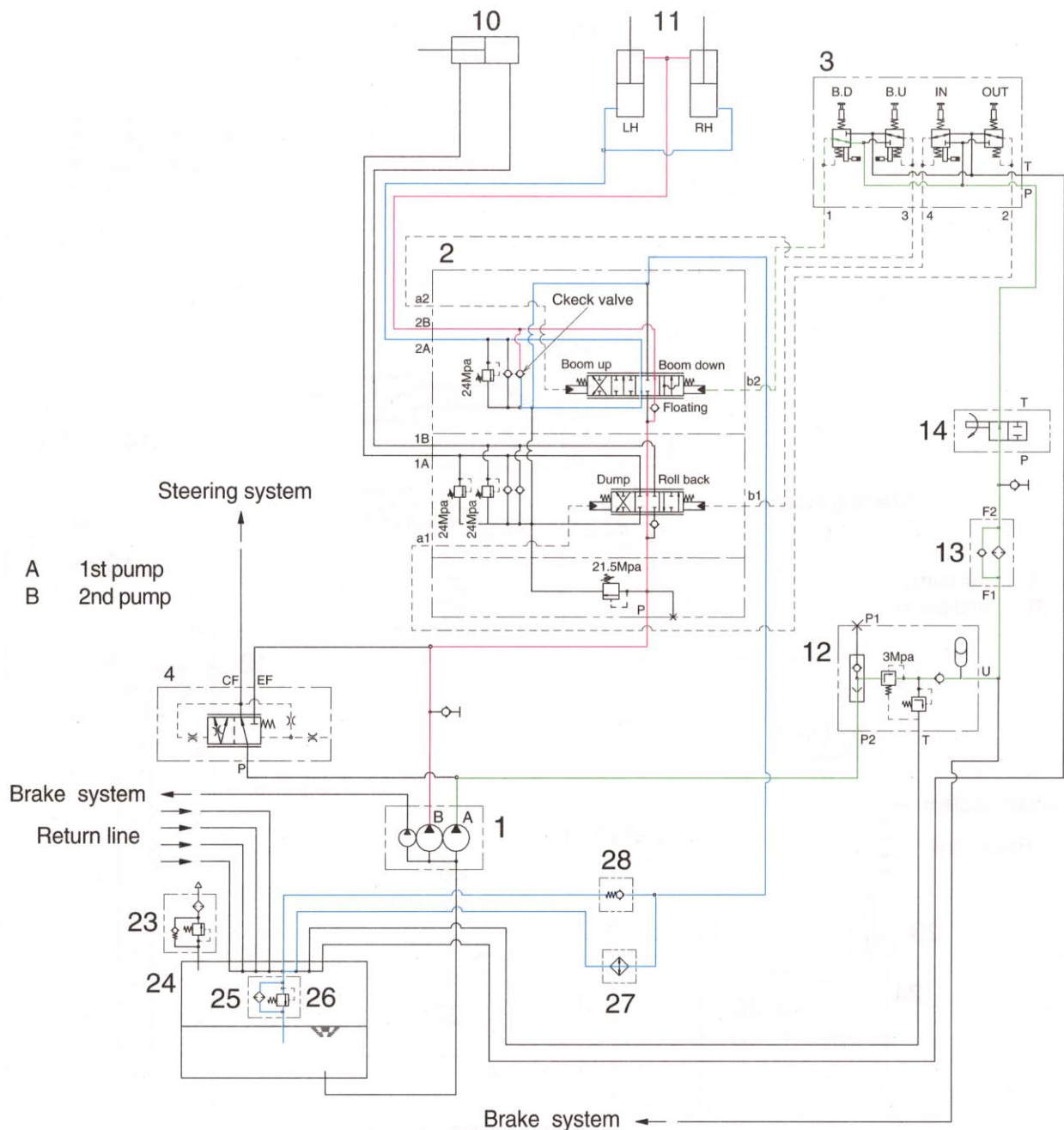

- When the RCV lever(3) is pushed forward, the boom spool on the second block is moved to lower position by pilot pressure from port 1 of RCV.
- The oil from main pump(1) flows into main control valve and then goes to small chamber of boom cylinder(11) by pushing the load check valve of the boom spool through center bypass circuit of the bucket spool.
- The oil returned from large chamber of boom cylinder(11) returns to hydraulic tank(24) through the boom spool at the same time.
- When the lowering speed of boom is faster, the return oil from the large chamber of boom cylinder combines with the oil from the pump through the check valve, and flows into the small chamber of the cylinder.

This prevents cylinder cavitation by the negative pressure when the pump flow cannot match the boom down speed.

### 3) WHEN THE RCV LEVER IS IN THE FLOAT POSITION

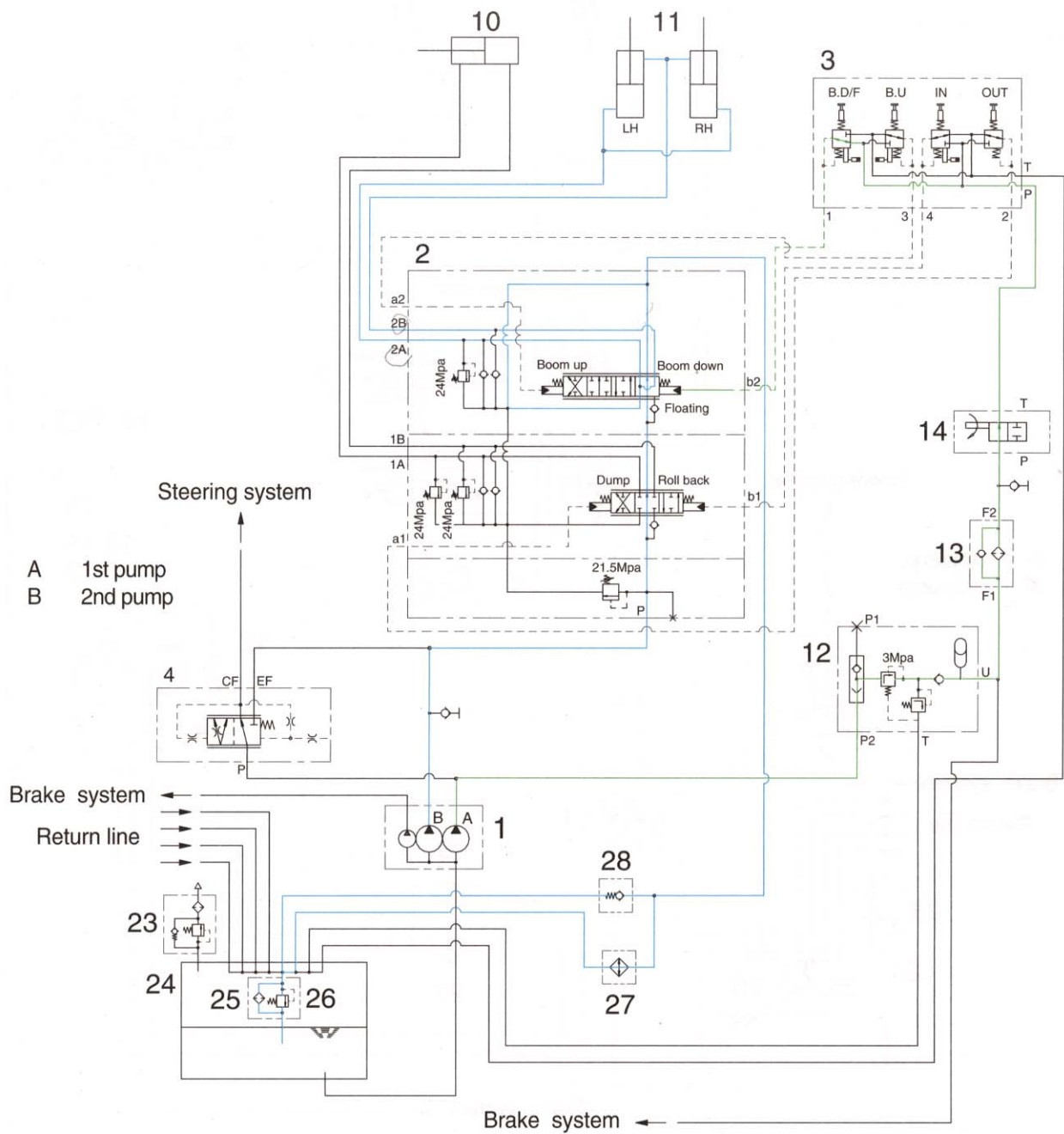

- When the RCV lever(3) is pushed further forward from the lower position, the pilot pressure reaches to 13-15 bar, then the boom spool on the second block is moved to floating position.
- The work ports(2A), (2B) and the small chamber and the large chamber are connected to the return passage, so the boom will be lowered due to it's own weight.
- In this condition, when the bucket is in contact with the ground, it can be move up and down in accordance with the shape of the ground.

#### 4) WHEN THE RCV LEVER IS IN THE DUMP POSITION

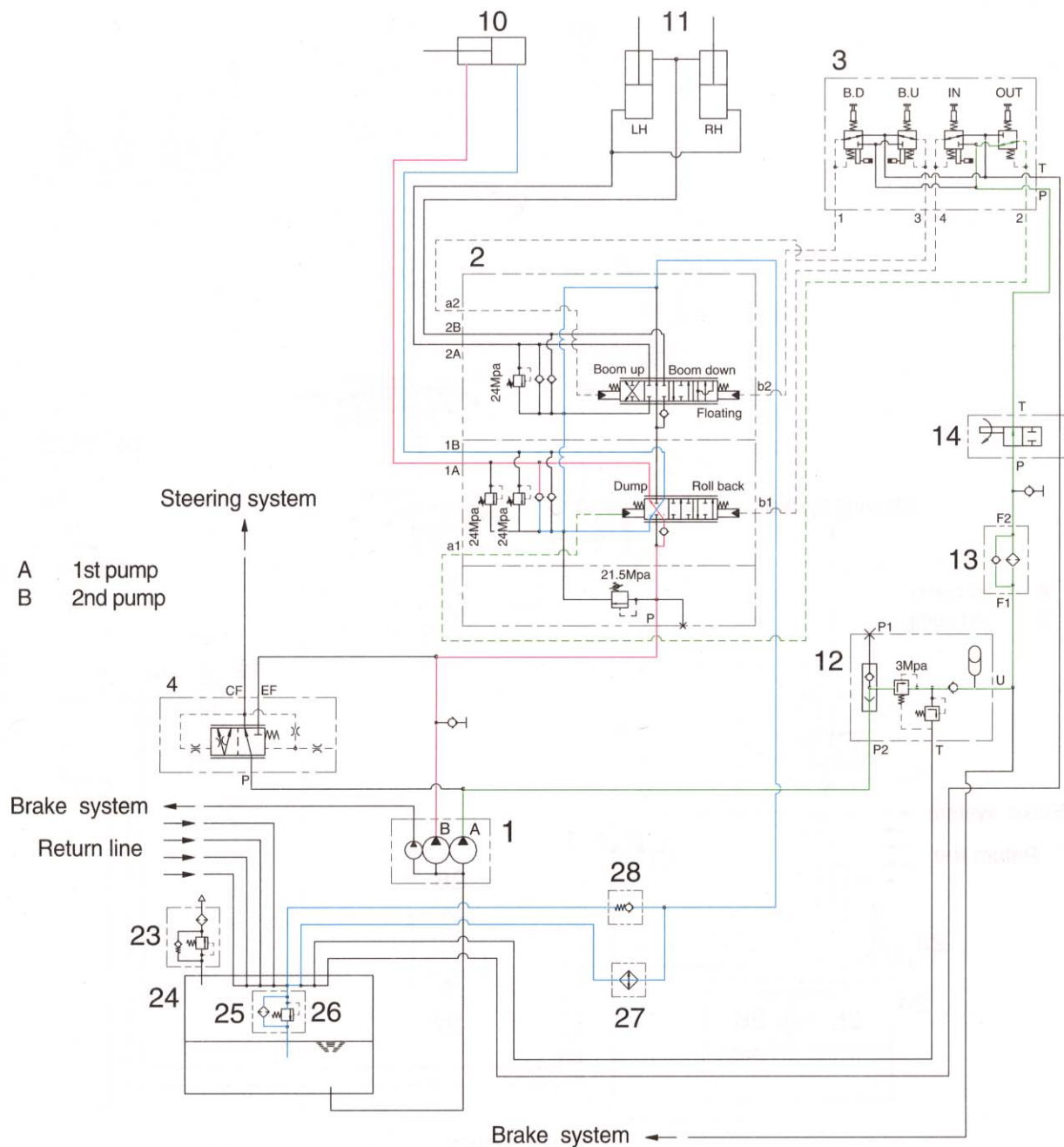

- If the RCV lever(3) is pushed right, the bucket spool on the first block is moved to dump position by pilot oil pressure from port 2 of RCV.
- The oil from main pump(1) flows into main control valve(2) and then goes to the small chamber of bucket cylinder(10) by pushing the load check valve of the bucket spool.
- The oil at the large chamber of bucket cylinder(10) returns to hydraulic tank(24) through the bucket spool.
- When this happens, the bucket is dumped.
- When the dumping speed of bucket is faster, the oil returned from the large chamber of bucket cylinder combines with the oil from the pump, and flows into the small chamber of the cylinder. This prevents cylinder cavitation by the negative pressure when the pump flow cannot match the bucket dump speed.

### 5) WHEN THE RCV LEVER IS IN THE ROLL BACK(Retract) POSITION

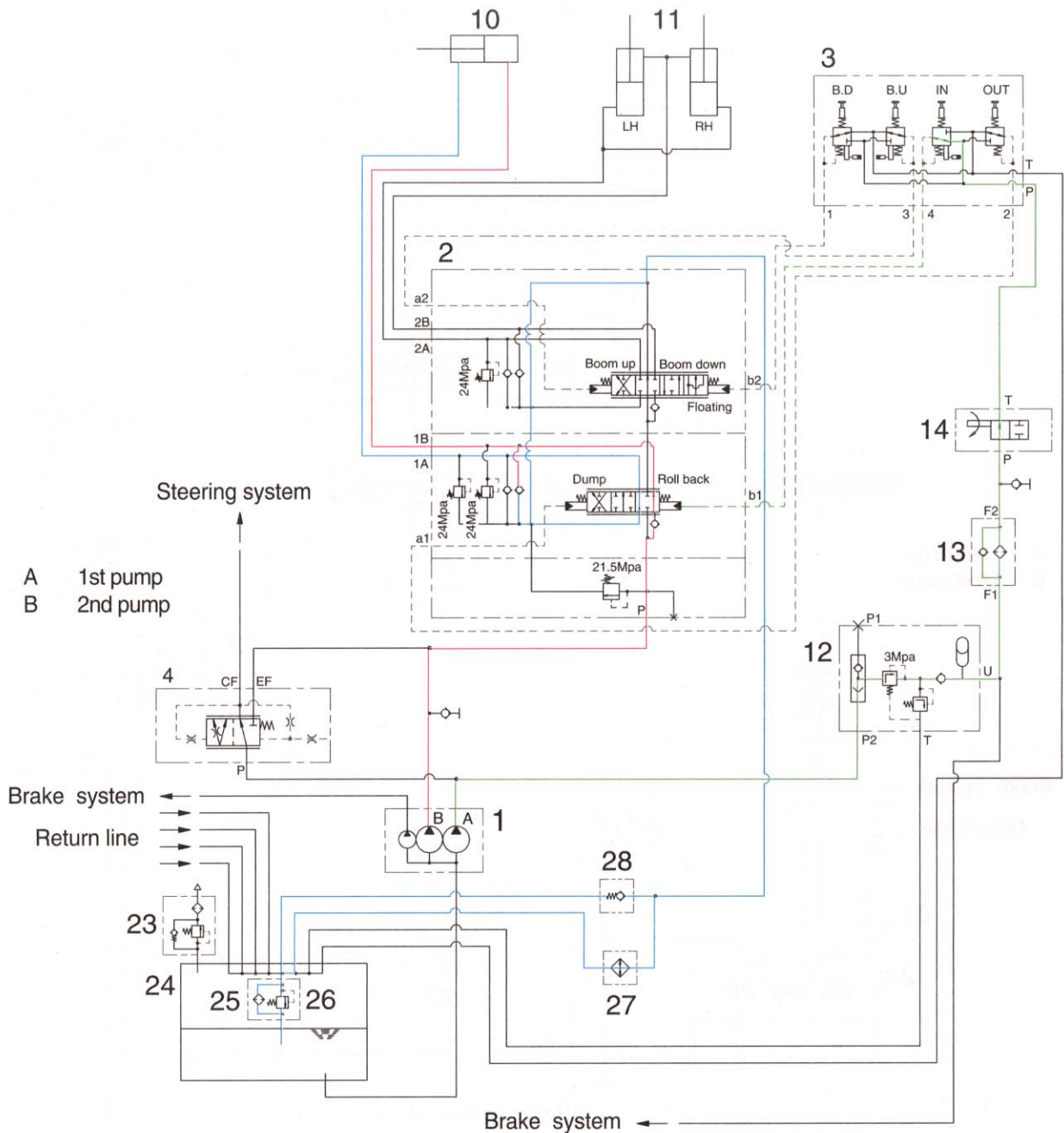

A 1st pump  
B 2nd pump

Steering system  
Brake system  
Return line

- If the RCV lever(3) is pulled left, the bucket spool on the first block is moved to roll back position by pilot oil pressure from port 4 of RCV.
- The oil from main pump(1) flows into main control valve(2) and then goes to the large chamber of bucket cylinder by pushing the load check valve of the bucket spool.
- The oil at the chamber of bucket cylinder(10) returns to hydraulic tank(24) through the bucket spool.
- When this happens, the bucket roll back.
- When the rolling speed of bucket is faster, the return oil from the small chamber of bucket cylinder combines with the oil from the pump, and flows into the large chamber of the cylinder. This prevents cylinder cavitation by the negative pressure when the pump flow cannot match the bucket rolling speed.



## 6) WHEN THE RCV LEVER IS IN THE HOLD POSITION

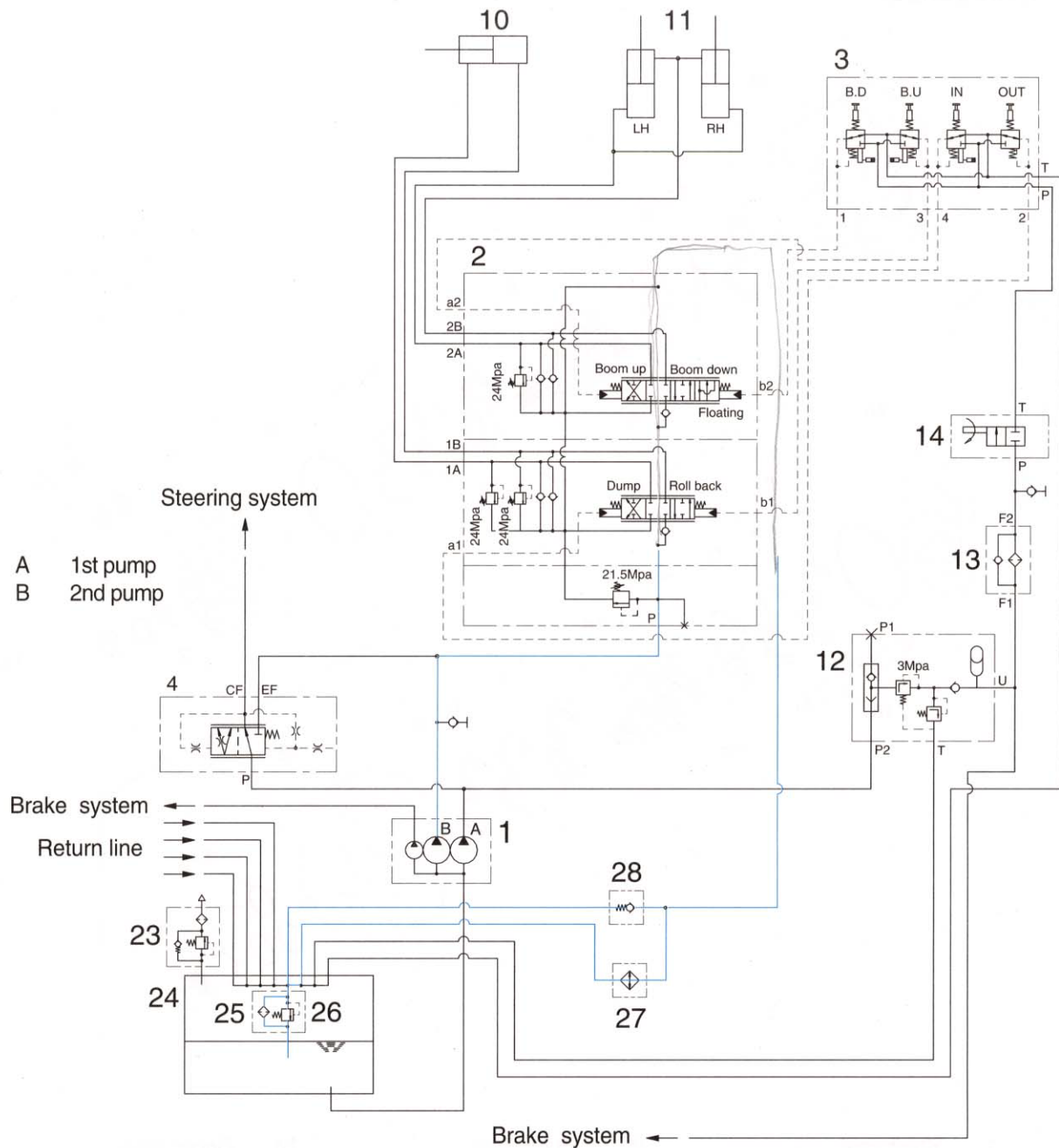

- The oil from main pump(1) flows into main control valve(2).
- In this time, the bucket spool and the boom spool are in neutral position, then the oil supplied to main control valve(2) returns into hydraulic tank(24) through center bypass circuit of each spool.
- In this condition, each cylinder keeps the neutral position, so the boom and the bucket is held.

### 3. MAIN PUMP OPERATION

#### 1) STRUCTURE

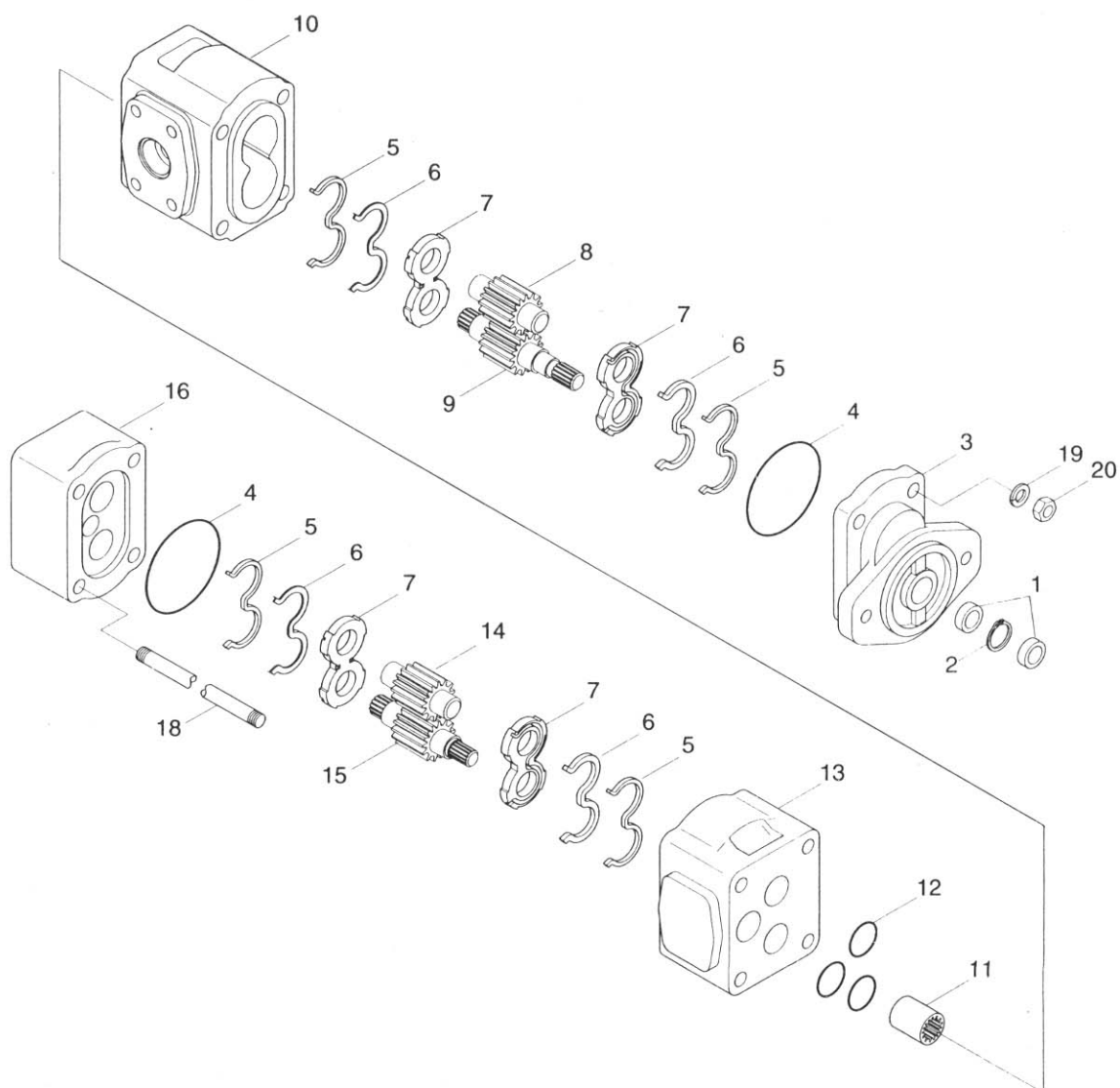

- |   |               |    |                  |    |                 |
|---|---------------|----|------------------|----|-----------------|
| 1 | Shaft seal    | 8  | Driven gear      | 14 | Driven gear     |
| 2 | Circlip       | 9  | Drive gear       | 15 | Drive shaft     |
| 3 | Flange        | 10 | Front body       | 16 | Cover           |
| 4 | O-ring        | 11 | Splined coupling | 18 | Stud assy       |
| 5 | Seal          | 12 | O-ring           | 19 | Serrated washer |
| 6 | Seal          | 13 | Center body      | 20 | Nut             |
| 7 | Balance plate |    |                  |    |                 |

## 2) OPERATION

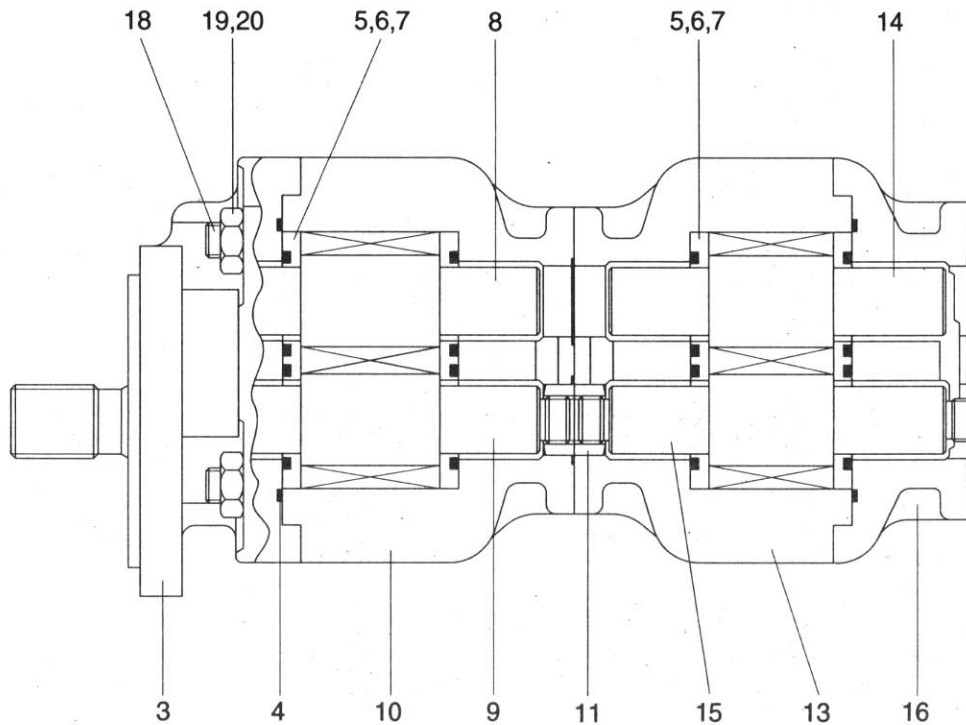

The main hydraulic pump is a fixed displacement gear type pump. The pump is drive at engine speed by the transmission. The pump shafts are supported by balance plates(7), flange(3), front body(10), center body(13) and cover(16).

As the drive gear(9) and (15) turns the driven gears(8, 14), the gear teeth come out of mesh. Oil flows from the hydraulic tank through the inlet into the cavity between the gear teeth. As the gears continue to rotate, the oil becomes trapped between the gear teeth and the balance plates(7). The trapped oil is then carried to the pump outlet. Oil is forced out the outlet to supply the hydraulic function. As the gears re-mesh, they form a seal to prevent oil from flowing between the gears and back to the inlet.

The pump uses outlet pressure oil to load the balance plates(7) against the gear faces. This controls internal leakage to maintain pump displacement.

Outlet pressure fills the area bounded by the seals(5, 6) to force the pressure plate against the high pressure area or the gear faces. Pump shaft lubrication is achieved by routing outlet pressure oil into the area between the gear shafts and the balance plates. The oil is collected at the end of the shafts in the hollow areas in the port and flange plates and routed back to return.

## 4. REMOTE CONTROL VALVE

### 1) STRUCTURE

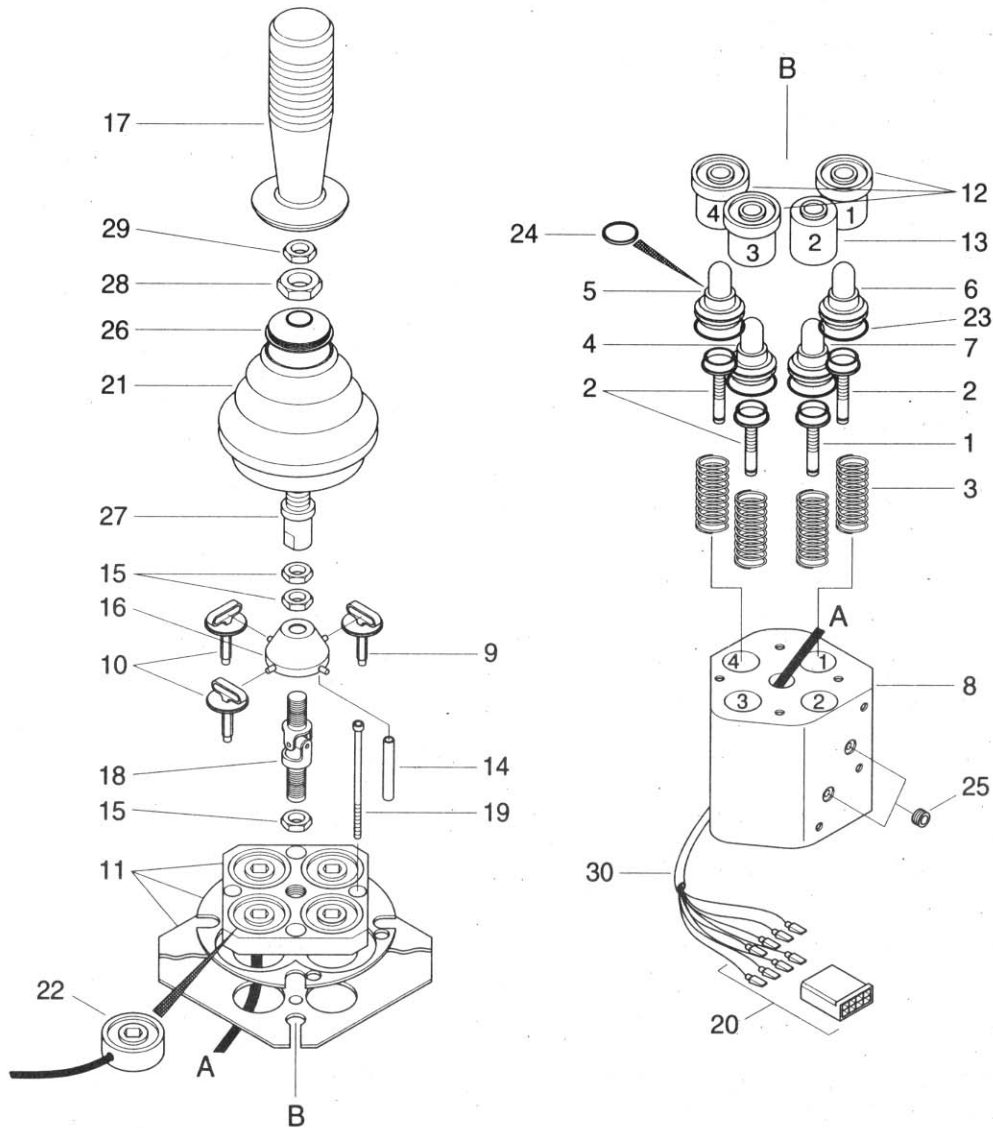

- |    |              |    |                   |    |                      |
|----|--------------|----|-------------------|----|----------------------|
| 1  | Spring pack  | 11 | Detent            | 21 | Rubber boot          |
| 2  | Spring pack  | 12 | Prefeel cage assy | 22 | Coil                 |
| 3  | Spring       | 13 | Spindle retainer  | 23 | O-ring               |
| 4  | Plunger assy | 14 | Spindle           | 24 | Wiper seal           |
| 5  | Plunger assy | 15 | Nut               | 25 | Plug                 |
| 6  | Plunger assy | 16 | Lever assy        | 26 | Boot retainer collar |
| 7  | Plunger assy | 17 | Handle assy       | 27 | Handle adapter       |
| 8  | Body         | 18 | Universal joint   | 28 | Nut                  |
| 9  | Prefeel      | 19 | Socket screw      | 29 | Nut                  |
| 10 | Prefeel      | 20 | Connector assy    | 30 | Tube                 |

## 2) OPERATION

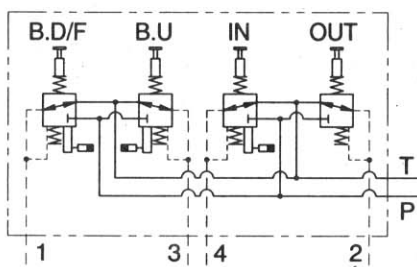
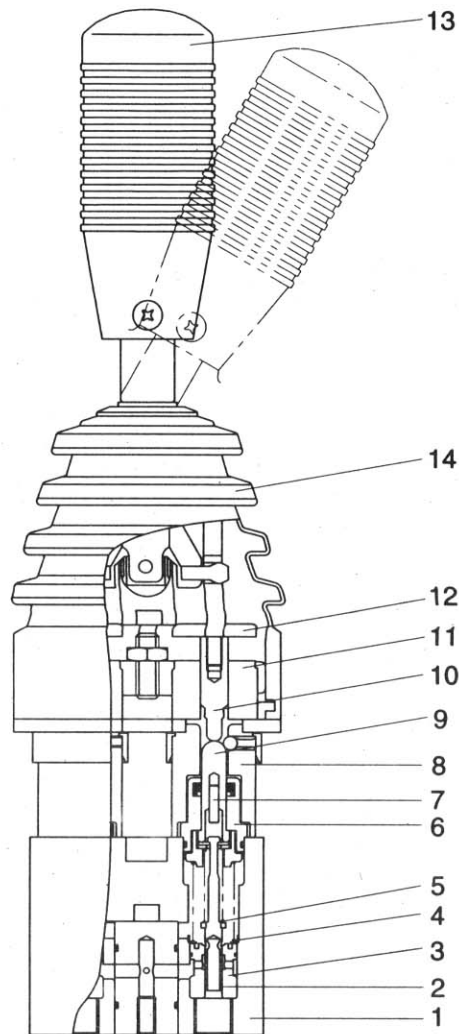

HYDRAULIC CIRCUIT

Port	Port name	Port size
1	Boom down	1/4 BSPP
2	Bucket dump	1/4 BSPP
3	Boom raise	1/4 BSPP
4	Bucket crowd	1/4 BSPP
P	Supply pressure	1/4 BSPP
T	Tank	1/4 BSPP

- |   |                         |    |                      |    |                |
|---|-------------------------|----|----------------------|----|----------------|
| 1 | Aluminum body           | 6  | Plunger guide        | 11 | Hold coil      |
| 2 | Pressure reducing spool | 7  | Roll pin             | 12 | Armature plate |
| 3 | Pressure reducing body  | 8  | Prefeel ball carrier | 13 | Control lever  |
| 4 | Return spring           | 9  | Plunger              | 14 | Rubber boot    |
| 5 | Metering spring         | 10 | Prefeel spindle      |    |                |

**(1) Neutral position**

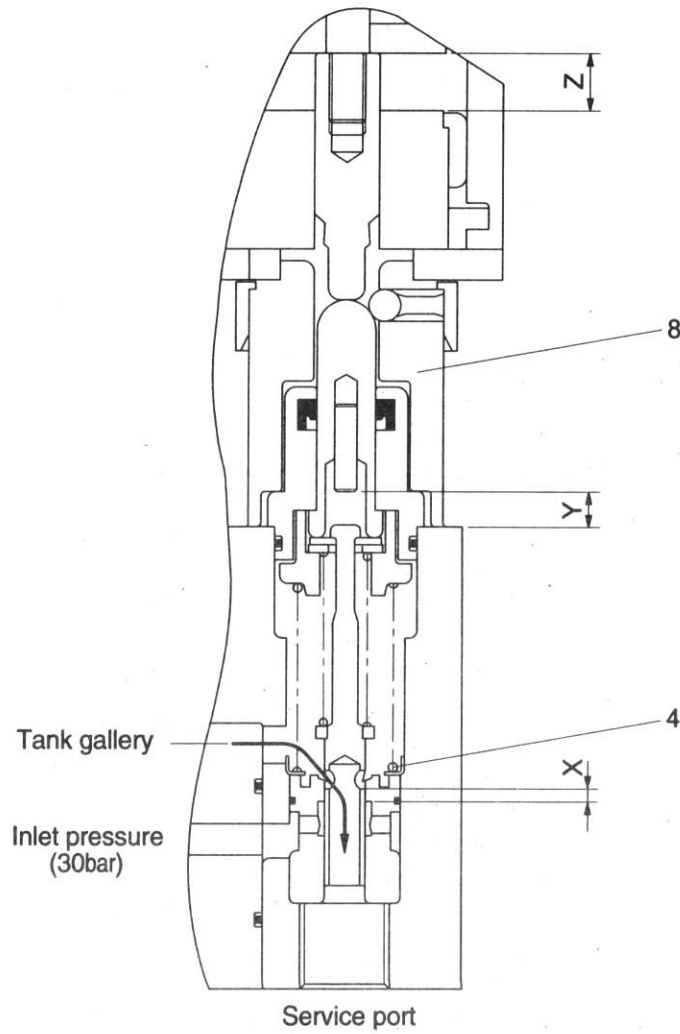

The rubber boot(14) fitted between the control lever(13) and the valve protects the working parts from external contamination. The return spring(4) holds the plunger(8) in its most upwardly position keeping the lever vertical. In this position all four service ports are connected to the tank gallery and hence to the tank port.

## (2) Metering position

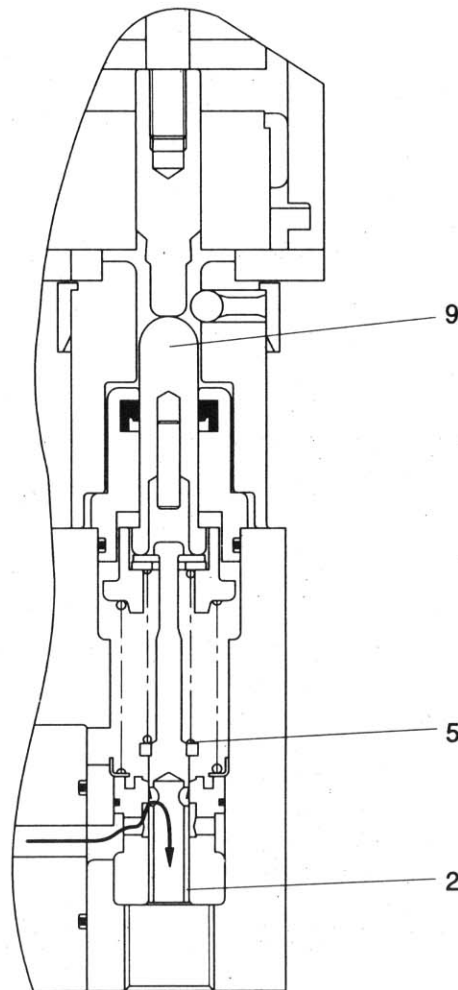

By selecting the control lever(13) the plunger(9) is progressively selected until the spool(2) deadband X is taken up. During this interval the service port is still connected to the tank gallery. Any further selection of the control lever(13) will ;

- ① Cause the four metering holes in the spool(2) to open slightly, allowing pressure to be raised at the service port. This increase in pressure then counteracts the load produced by the metering spring(5) closing off the opening until an equilibrium is maintained. The pressure raised at the service port is proportional to the rate of the metering spring. The initial jump in pressure is caused by the preload in the metering spring(5) and can be altered as required simply by adjusting the shimming.
- ② Cause the service port to shut off to the tank gallery.

### (3) End of metering

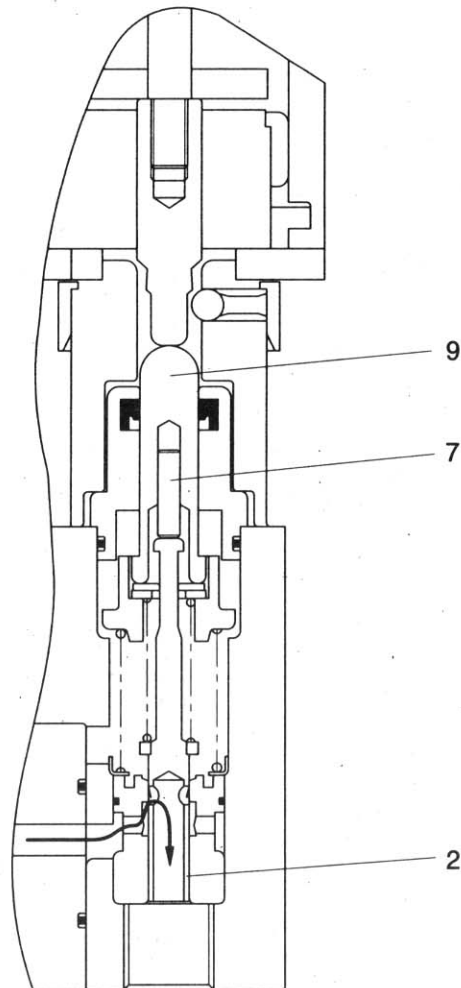

After the plunger(9) has been displaced a distance of  $X+Y$ , the plunger roll pin(7) is just contacting the top of the spool(2). Any further selection of the control lever(13) will cause the four metering holes in the spool(2) to open independently of the pressure.

Thus any selection of the control lever(13) past  $X+Y$  will cause the service pressure to increase immediately to inlet pressure.



#### (4) Fully selected

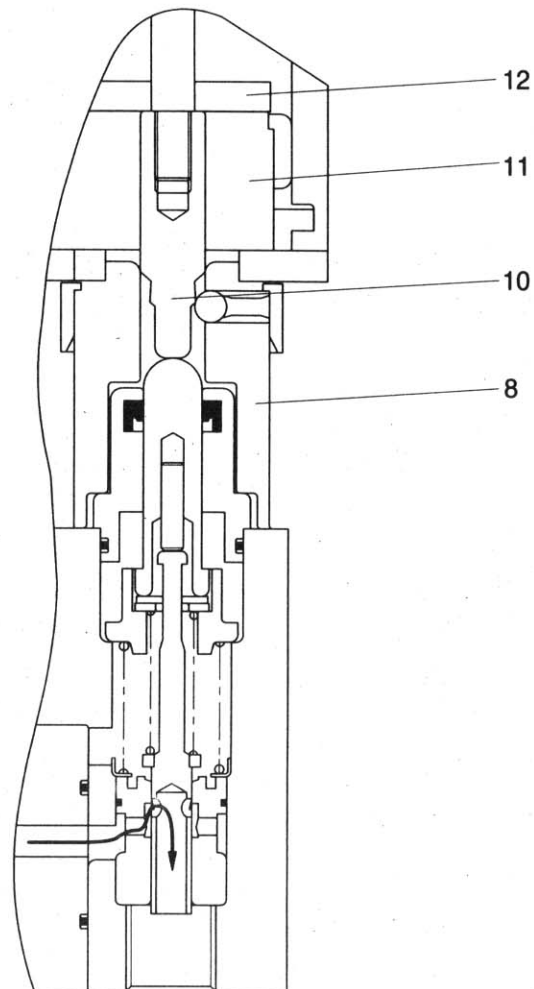

Selecting the control lever(13) now will maintain the service port pressure at inlet until the armature plate(12) contacts on the hold coil(11). However, just prior to this, the ramp on the prefeel spindle(10) reacts against the three springs in the prefeel ball carrier(8).

This produces a sharp increase in operator load(Prefeel), ensuring that the service is not accidentally selected through to detent.

## 5. MAIN CONTROL VALVE

### 1) STRUCTURE

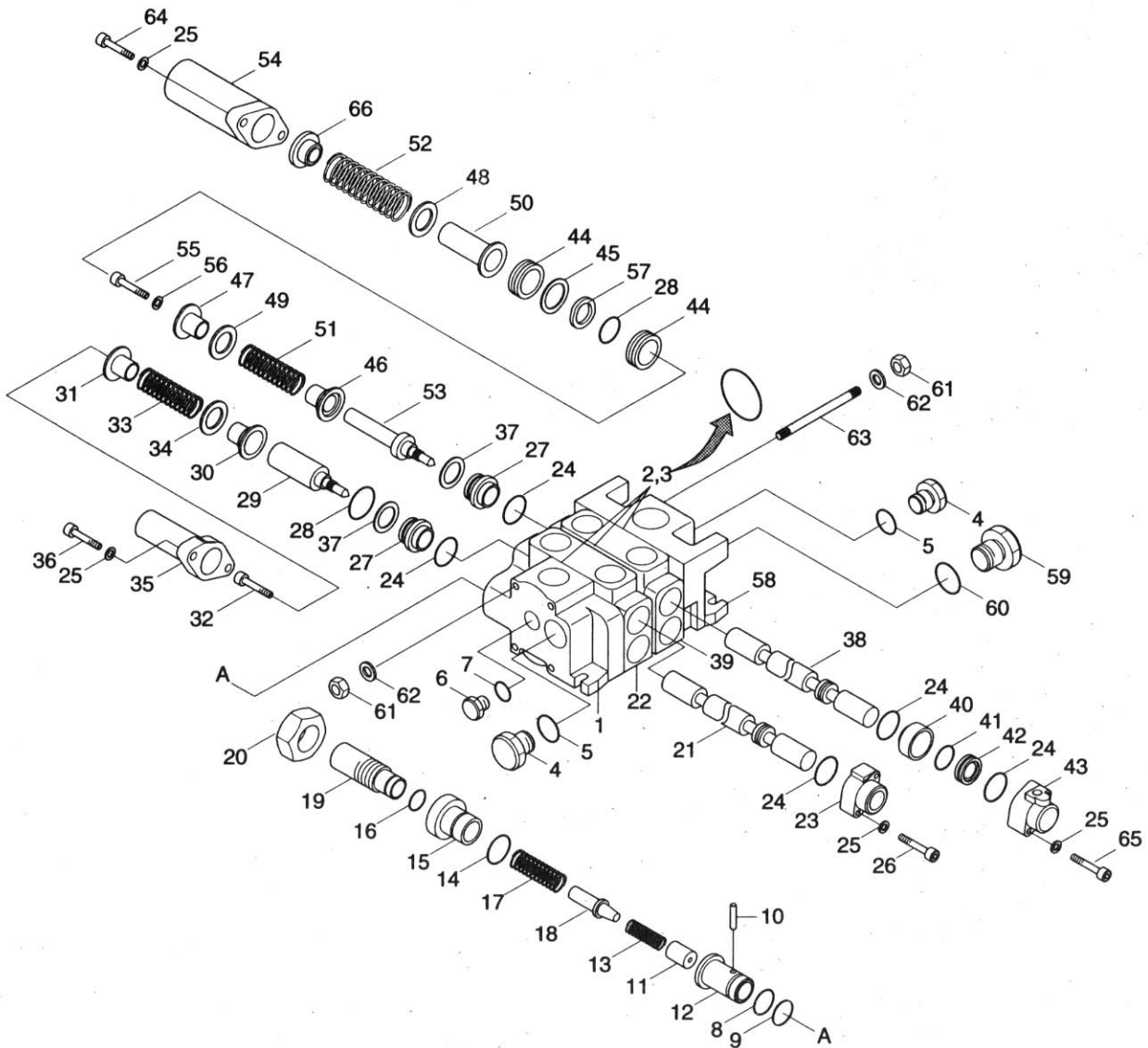

1	Inlet housing	15	Pilot housing	29	Adaptor	43	Cover	57	O-ring
2	O-ring	16	O-ring	30	Spring retainer	44	Seal retainer	58	Outlet housing
3	O-ring	17	Spring	31	Spring retainer	45	Circlip	59	Plug
4	Plug	18	Poppet	32	Screw	46	Spring retainer	60	O-ring
5	O-ring	19	Adjusting screw	33	Spring	47	Spring reatiner	61	Hexagon nut
6	Plug	20	Lock nut	34	Shim	48	Shim	62	Washer
7	O-ring	21	Spool	35	Cover	49	Shim	63	Tie stud
8	O-ring	22	Spool section	36	Bolt	50	Spring retainer	64	Screw
9	Back up ring	23	Cover	37	Shim	51	Spring	65	Screw
10	Pin	24	O-ring	38	Spool	52	Spring	66	Stop
11	Plunger	25	Lock washer	39	Spool section	53	Spool cap		
12	Sleeve	26	Bolt	40	Seal extention	54	Cover		
13	Spring	27	Seal retainer	41	O-ring	55	Screw		
14	O-ring	28	O-ring	42	Sleeve	56	Washer		

## STRUCTURE

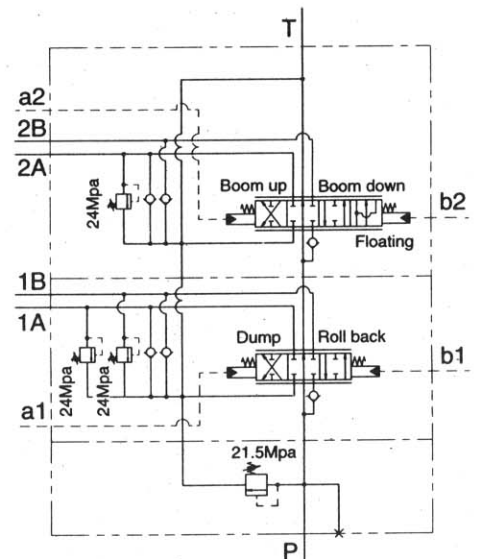
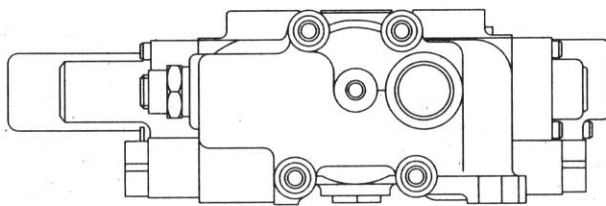
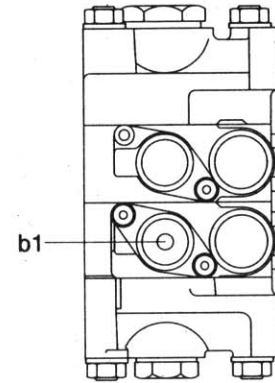
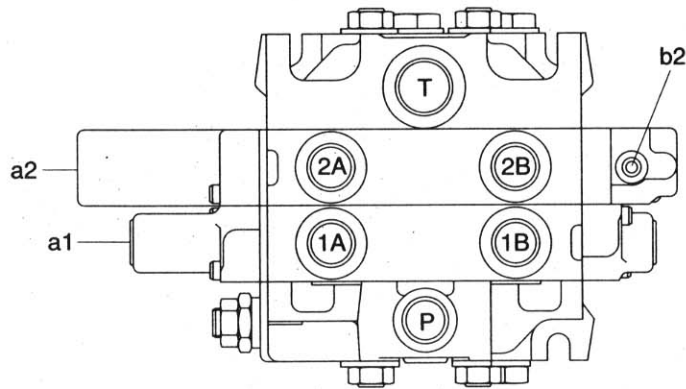

Port	Port name	Port size
P	From main pump	1 1/16UNF
T	To hydraulic tank	1 5/16UNF
1A, 1B	To bucket cylinder port	1 1/16UNF
2A, 2B	To boom cylinder port	1 1/16UNF
a1, b1	Bucket pilot port	7/16UNF
a2, b2	Boom pilot port	7/16UNF

## 2) BOOM SECTION OPERATION

### (1) Spool in neutral

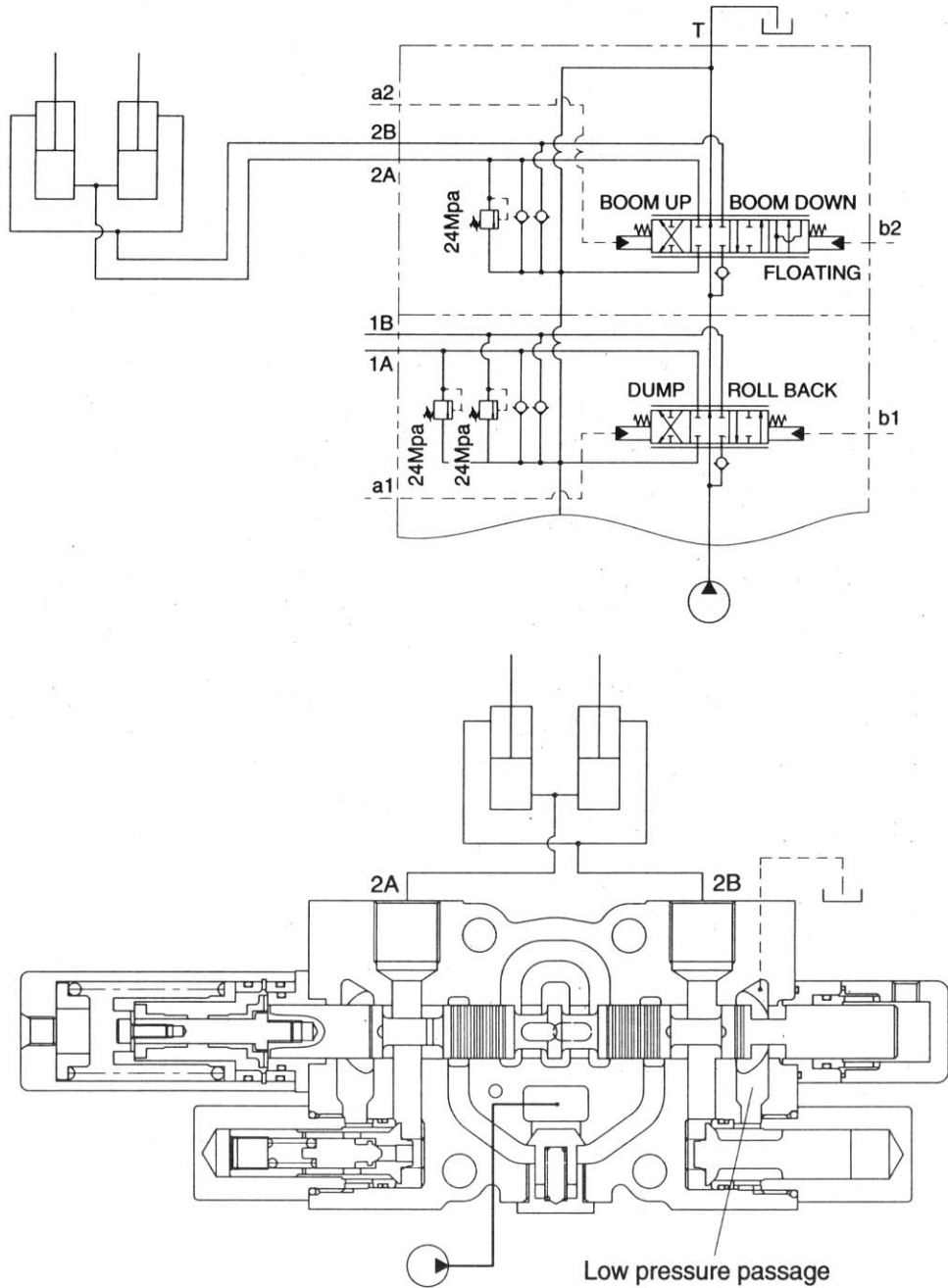

If the remote control valve is not operated, the oil supplied from the pump port passes through the neutral passage to the low pressure passage at the outlet section, and then returns to the tank port.

**(2) Boom raise position**

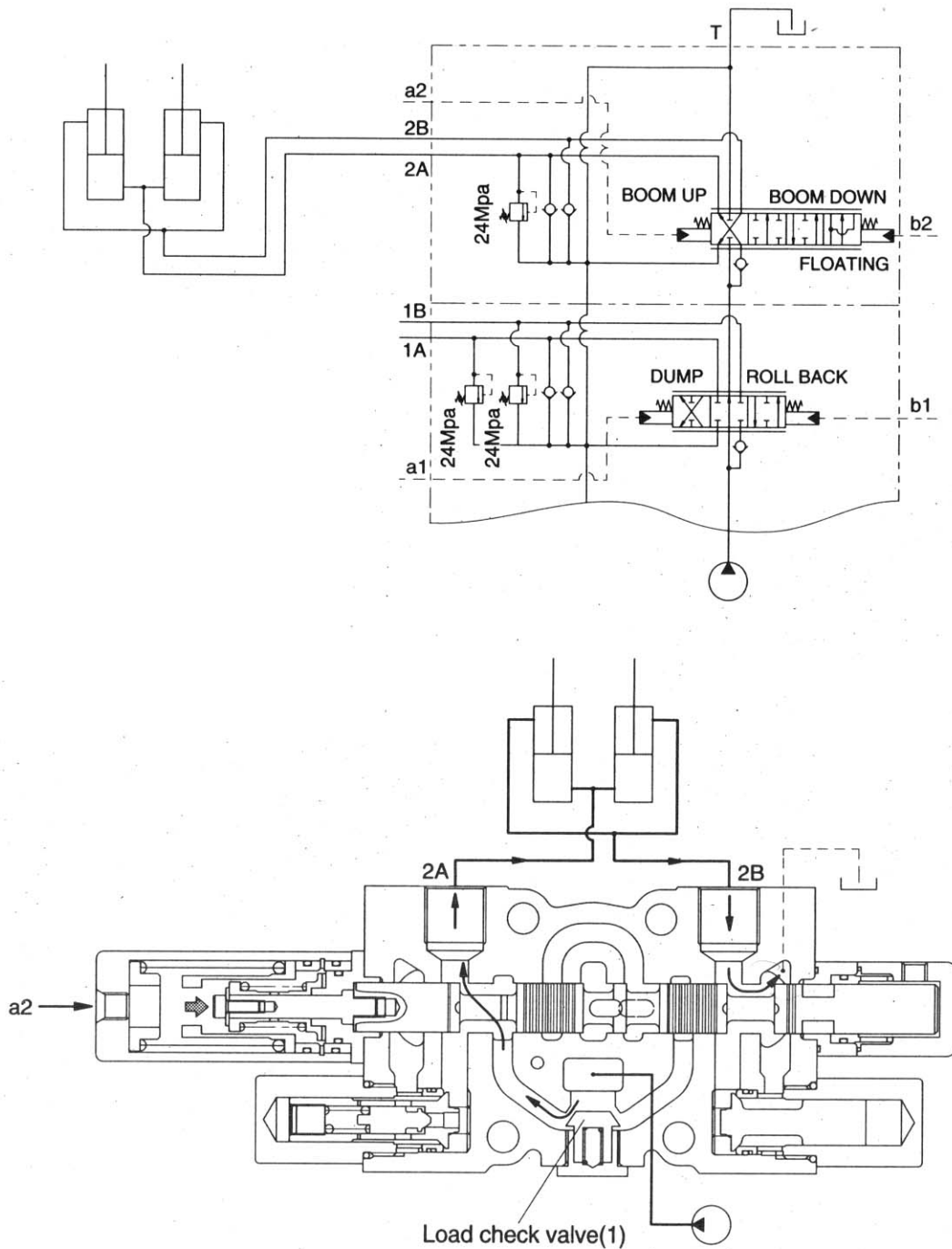

When the pilot pressure from remote control valve is supplied to the pilot port(a2), the spool moves to the right and the neutral passage is closed.

The oil supplied from the pump pushes up the load check valve(1) and flow into boom cylinder port(2A).

The pump pressure reaches proportionally the load of cylinder and fine control finished by shut off of the neutral passage.

The return oil from cylinder port(2B) flows into the tank via the low pressure passage.

**(3) Boom lower position**

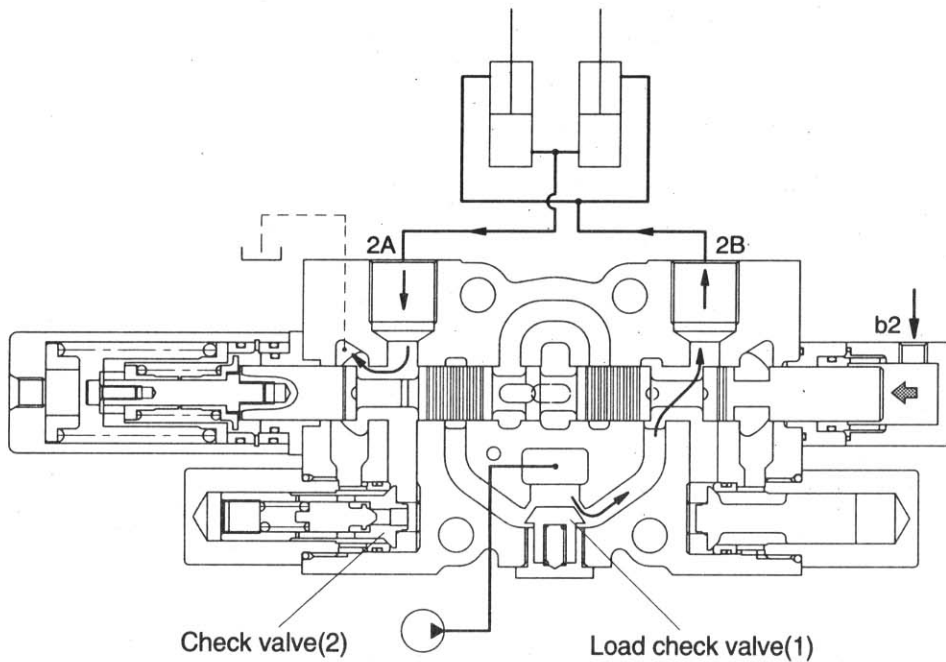
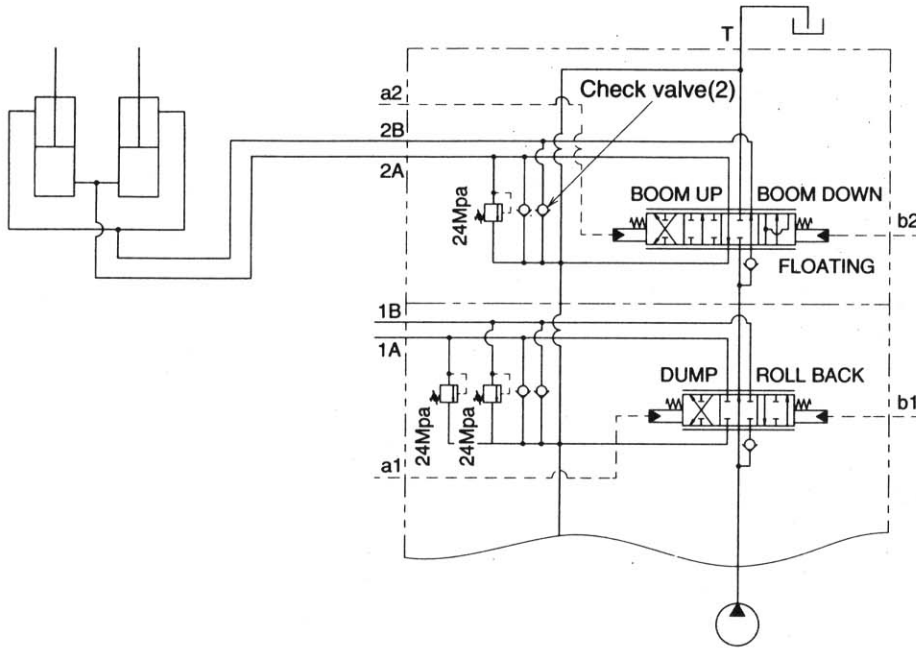

When the pilot pressure from remote control valve is supplied to the pilot port(b2), the spool moves to the left and the neutral passage is closed.

The oil supplied from the pump pushes up the load check valve(1) and flow into boom cylinder port(2B). The pump pressure reaches proportionally the load of cylinder and fine control finished by shut off of the neutral passage.

The return oil from cylinder port(2A) flows into the tank via the low pressure passage.

When the lowering speed of boom is faster, the return oil from the large chamber of boom cylinder combines with the oil from the pump through the check valve(2), and flows into the small chamber of cylinder. This prevents cylinder cavitation by the negative pressure when the pump flow cannot match the boom lowering speed.

#### (4) Boom float position

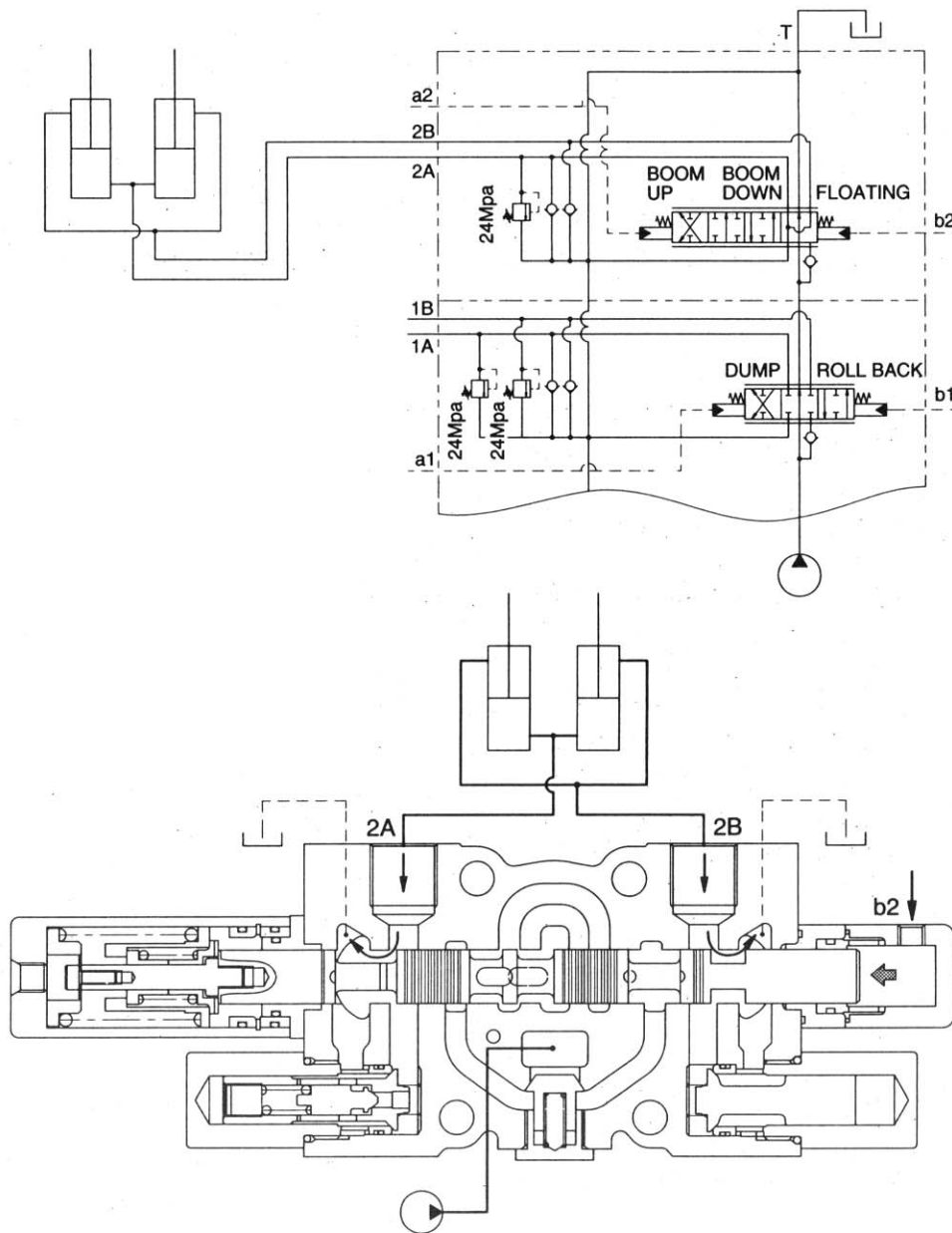

If the remote control lever pushes further more, the pilot pressure from remote control valve rises over 13-15bar and then the boom lowering spool is pushed to the boom floating position, opening up the neutral passage to tank and simultaneously(2A), (2B) → T.

In float position the boom drops quickly due to its own weight.

When the bucket touches the ground and the wheeled loader is moving, the bucket raised or lowered following the unevenness of the ground due to the (2A), (2B) → T connecting.

### 3) BUCKET SECTION OPERATION

#### (1) Spool in neutral

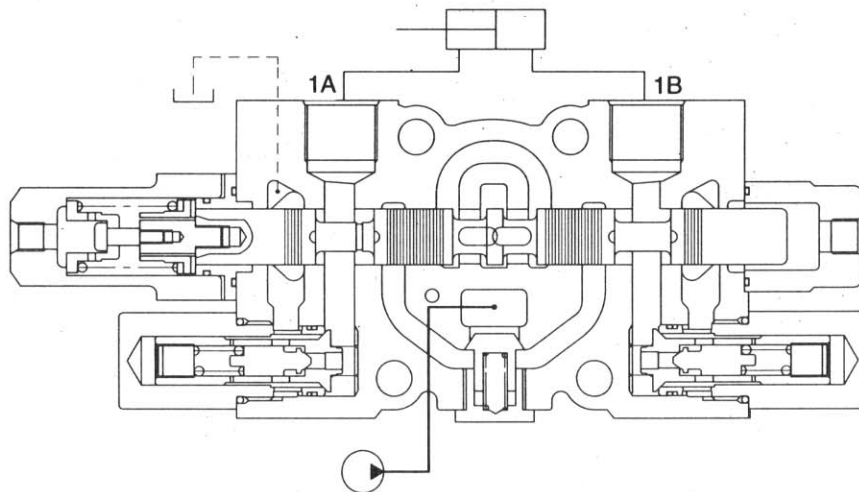
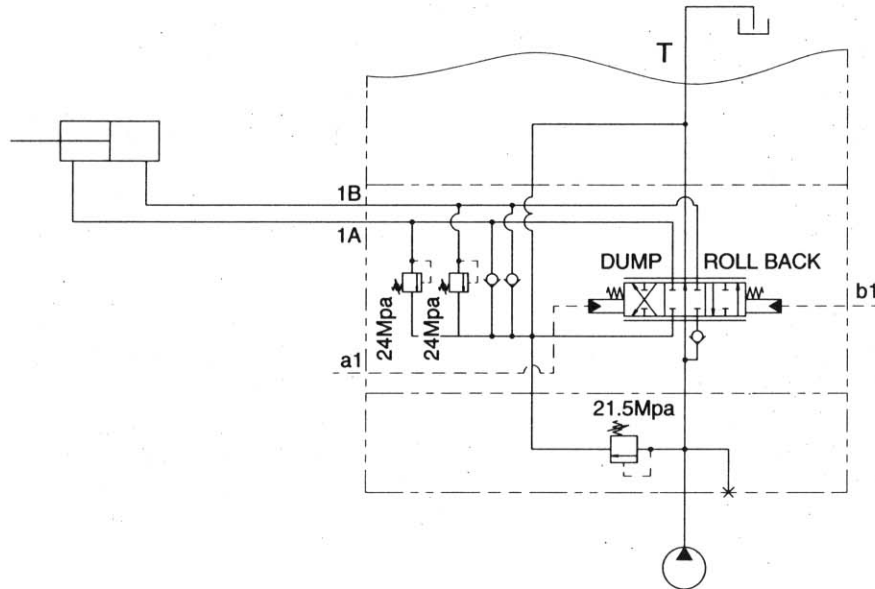

If the remote control valve is not operated, the oil supplied from the pump port passage through the neutral passage to the low pressure passage at the outlet section, and then return to the tank port.



**(2) Retract(Roll back) position**

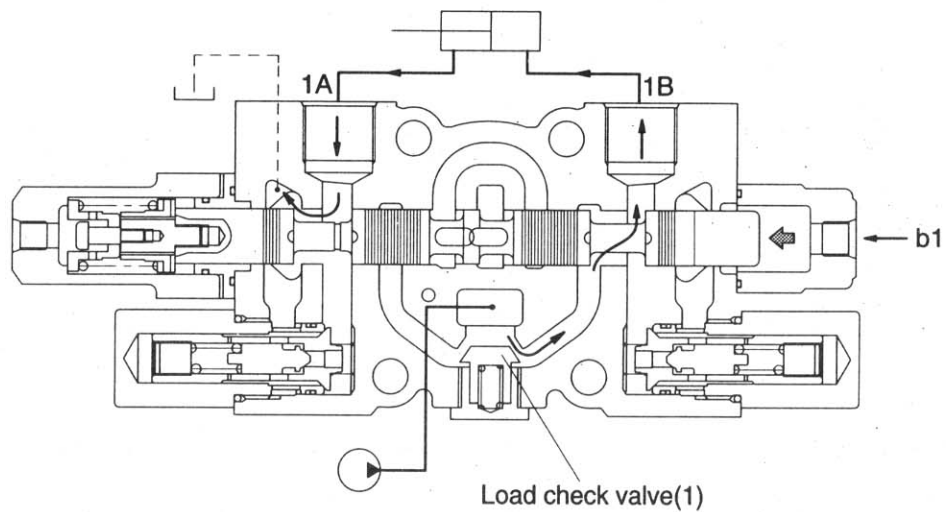
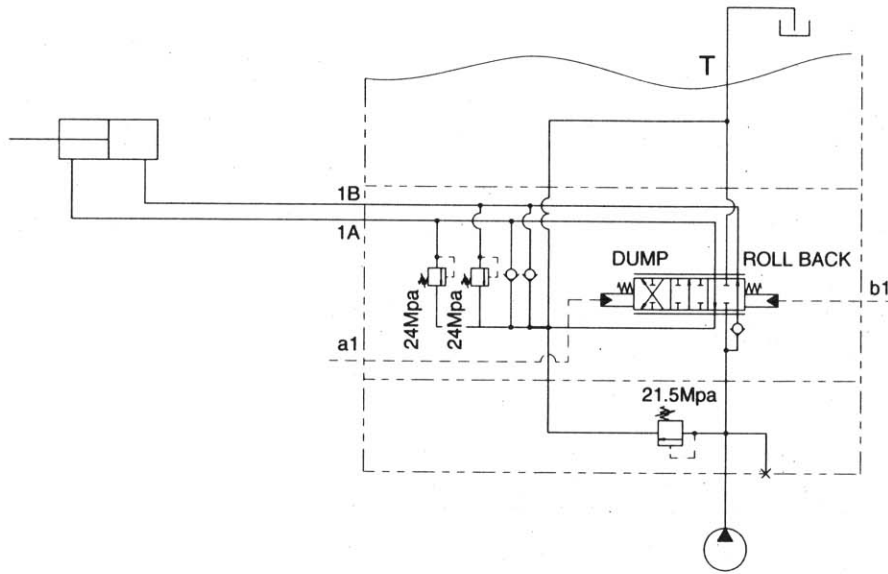

When the pilot pressure from remote control valve is supplied to the pilot port(b1), the spool moves to the left and the neutral passage is closed.

The oil supplied from the pump pushes up the load check valve(1) and flow into boom cylinder port(1B). The pump pressure reaches proportionally the load of cylinder and fine control finished by shut off of the neutral passage.

The return oil from cylinder port(1A) flows into the tank via the low pressure passage.

**(3) Dump position**

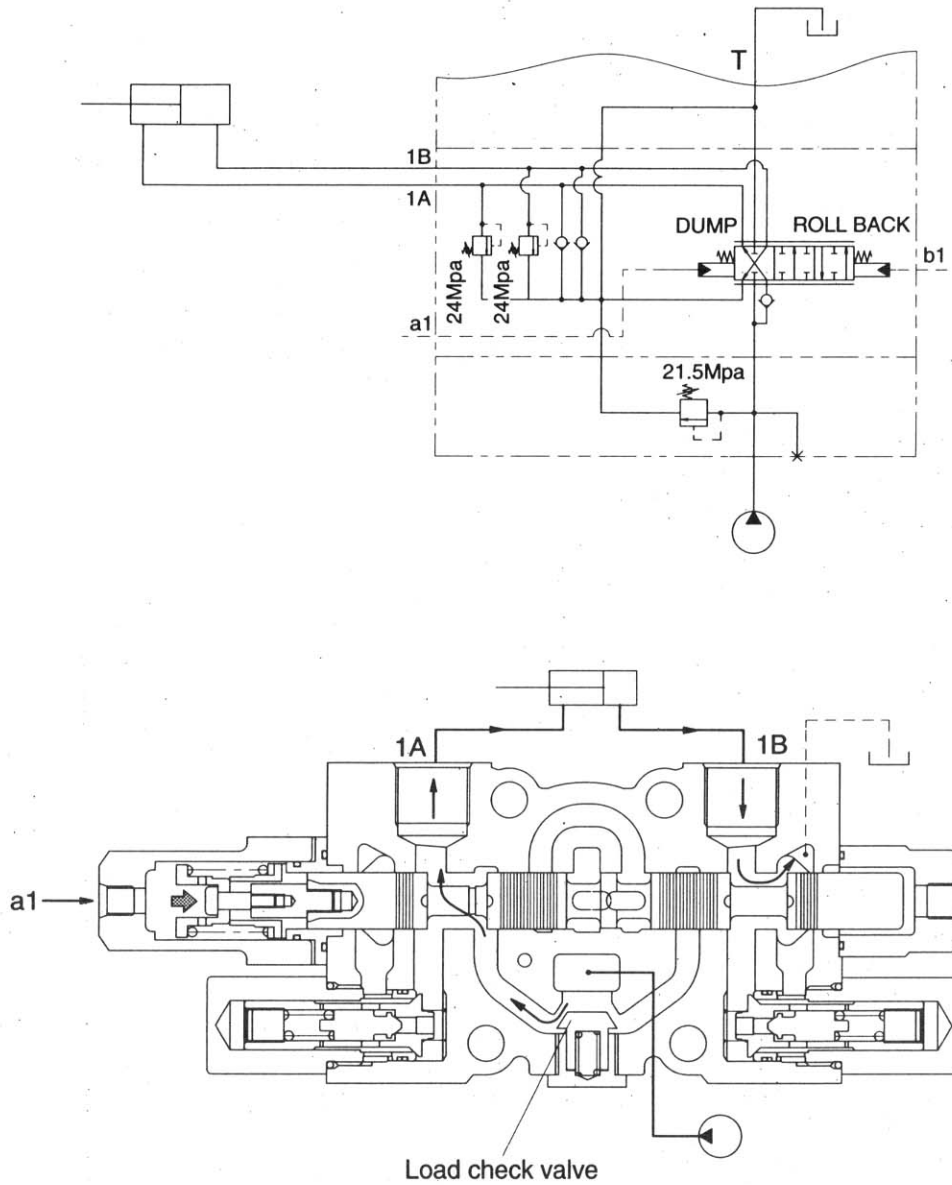

When the pilot pressure from remote control valve is supplied to the pilot port(a1), the spool moves to the right and the neutral passage is closed.

The oil supplied from the pump pushes up the load check valve(1) and flow into boom cylinder port(1A). The pump pressure reaches proportionally the load of cylinder and fine control finished by shut off of the neutral passage.

The return oil from cylinder port(1B) flows into the tank via the low pressure passage.

#### 4) MAIN RELIEF VALVE

- The main relief valve is installed at the inlet of the main control valve. When the oil goes above the set pressure, the relief valve drains the oil to the tank. In this way, it sets the maximum pressure in the hydraulic circuit and protects the circuit.
- The valve poppet(C) is connected via the throttle drillings(D1) and (D2) with the P port. If static pressure increases above the set pressure valve, the valve poppet(C) opens and allows oil to flow freely to tank(Y). This oil generates a pressure drop in the spring chamber of the main poppet, the closing force of the spring(Z) is cancelled, and the main poppet(A) opens to allow the pump flow to flow to tank(T). Damped opening and closing is obtained by the throttled volumetric change.

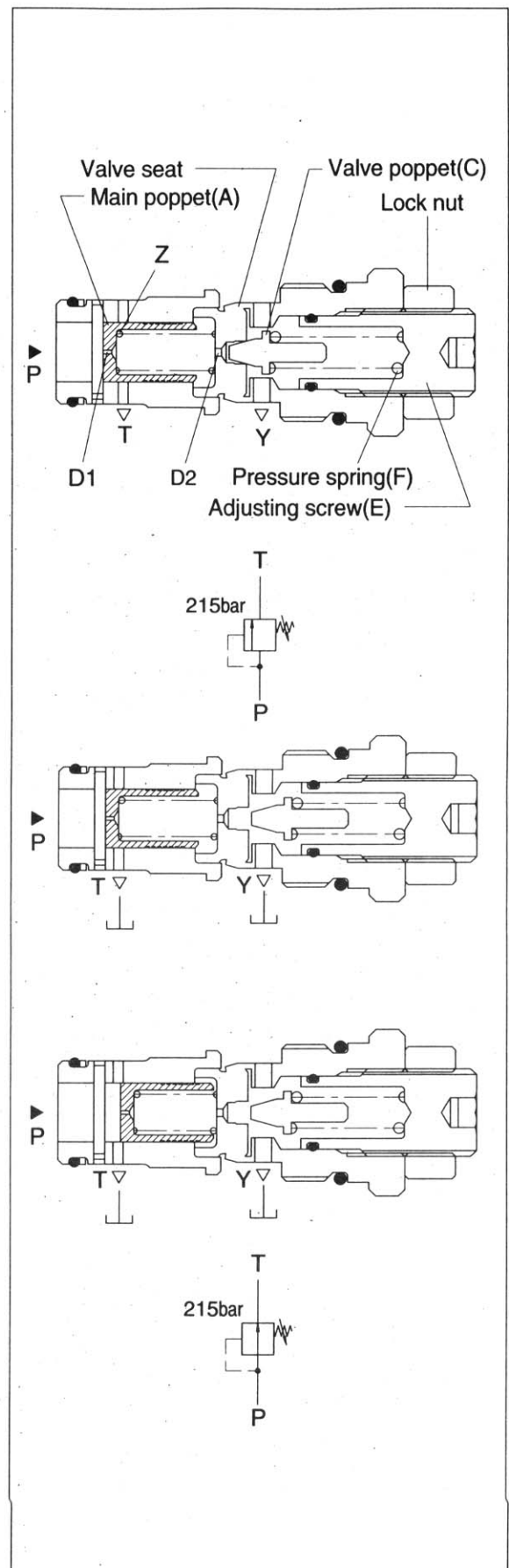

## 5) PORT RELIEF VALVE

- The overload relief valve (Combined relief/anticavitation valve) is in the boom cylinder and bucket cylinder circuit in the main control valve.

If shock causes any abnormally high pressure in the cylinder when the main valve is at neutral, the overload relief valve releases the abnormal pressure and protects the cylinder from damage.

- Pressure oil flows into passage(1). The oil acts against the left side of valve(2), when is held closed by spring(4).

When a shock causes pressure in any of the cylinders to rise, the increase in pressure is also sensed in passage(1). As the pressure rises above the pressure setting, the oil overcomes the force of spring(4) and valve(2) will move to the right.

Oil in passage(1) then flows past the open valve, through passage, and back to the hydraulic oil tank.

When oil pressure returns to a level below the pressure setting, spring(4) moves valve(2) to the left and onto the seat.

- If cavitation in the workport occurs, the oil pressure in the workport drop below return pressure.

With the workport pressure below return pressure, the return pressure works against the shoulder of the poppet(5), causing it to open against the spring(3).

Return pressure oil flows into the workport to prevent cylinder cavitation.

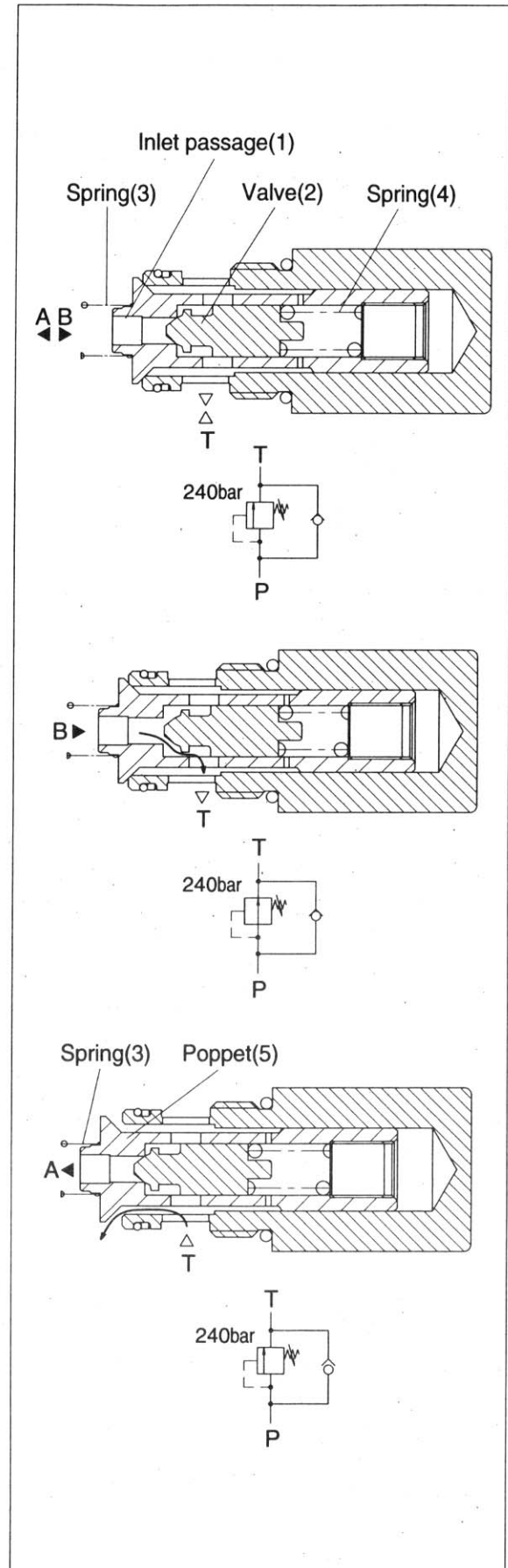

## 6) PRESSURE SETTING

A good pressure gage must be installed in the line which is in communication with the work port relief. A load must be applied in a manner to reach the set pressure of the relief unit.

### (1) Main relief valve

- ① Loosen lock nut.
- ② Set adjusting screw to desired pressure setting.
- ③ Tighten lock nut.
- ④ Retest in similar manner as above.

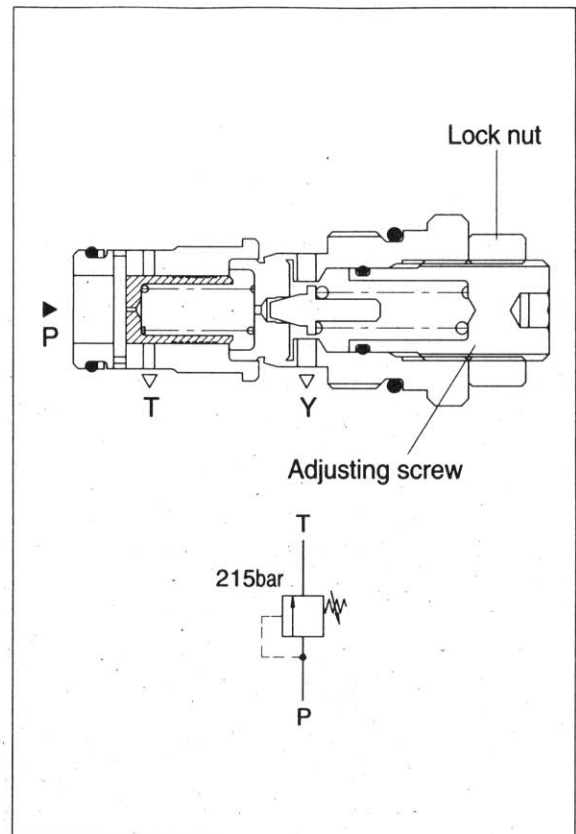

### (2) Port relief valve

- ① Loosen valve housing.
- ② Set adjusting screw to desired pressure setting.
- ③ Tighten valve housing.
- ④ Retest in similar manner as above.

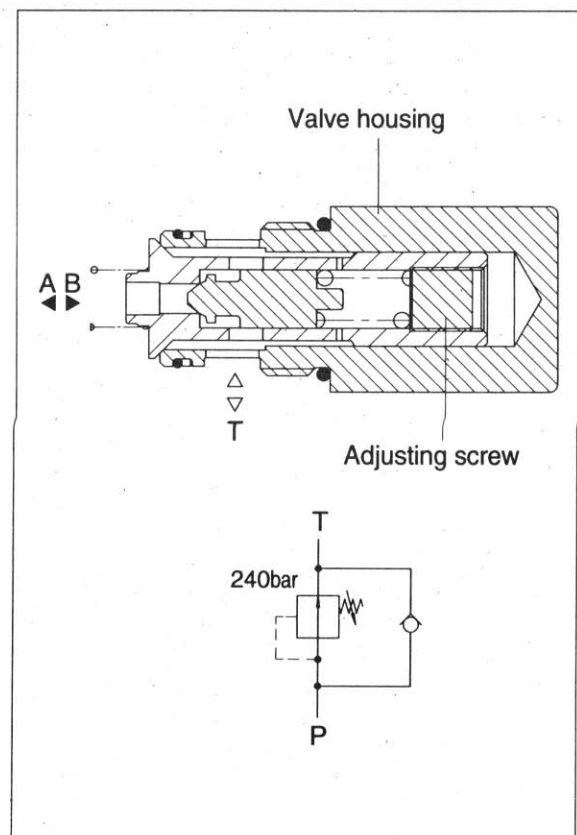

## 6. PILOT OIL SUPPLY UNIT

### 1) STRUCTURE

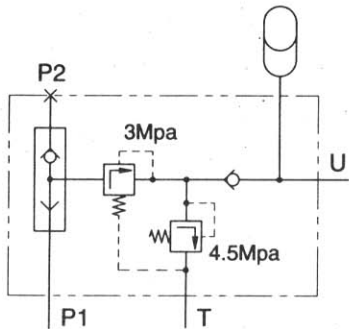
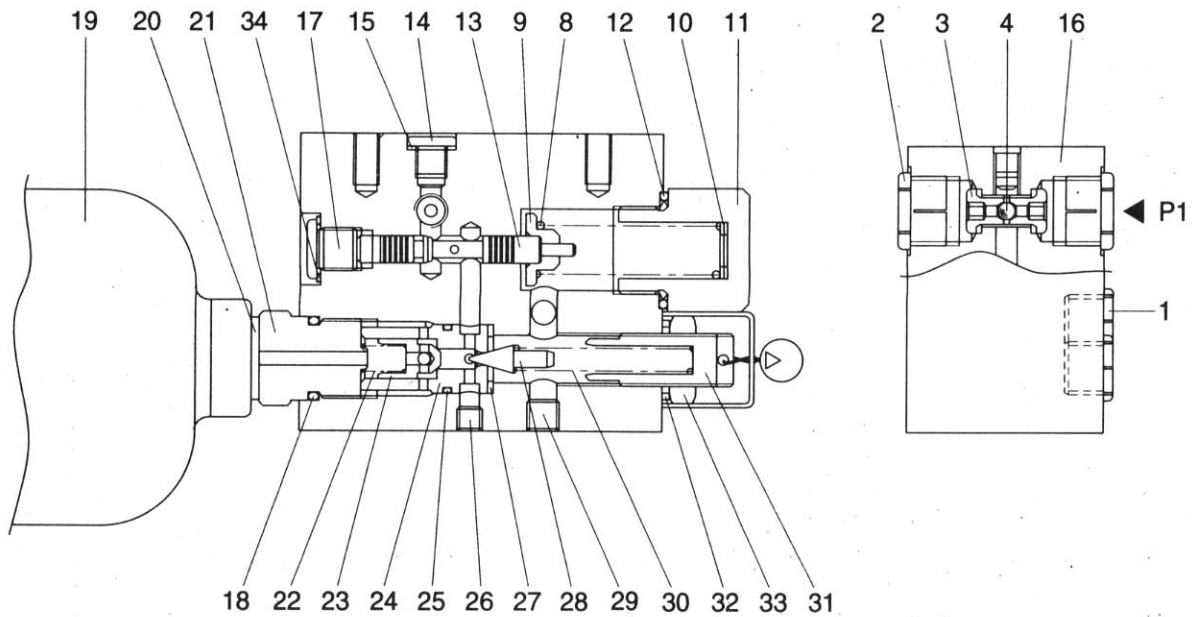

HYDRAULIC CIRCUIT

Port	Port name	Port size
P1	From main pump	3/4 UNF
P2	Plugging	3/4 UNF
U	Supply to RCV lever	9/16 UND
T	To hydraulic tank	9/16 UND

- |                |                  |                    |
|----------------|------------------|--------------------|
| 1 Plug         | 14 Plug          | 24 Valve seat      |
| 2 Plug         | 15 Copper washer | 25 O-ring          |
| 3 Seat         | 16 Housing       | 26 Plug            |
| 4 Ball         | 17 Plug          | 27 Copper washer   |
| 8 Spring       | 18 O-ring        | 28 Valve poppet    |
| 9 Spring guide | 19 Accumulator   | 29 Plug            |
| 10 Shim        | 20 Seal          | 30 Spring          |
| 11 Plug        | 21 Adapter       | 31 Adjusting screw |
| 12 Seal        | 22 Spring        | 32 Washer          |
| 13 Spool       | 23 Check valve   | 33 Nut             |

## 2) OPERATION

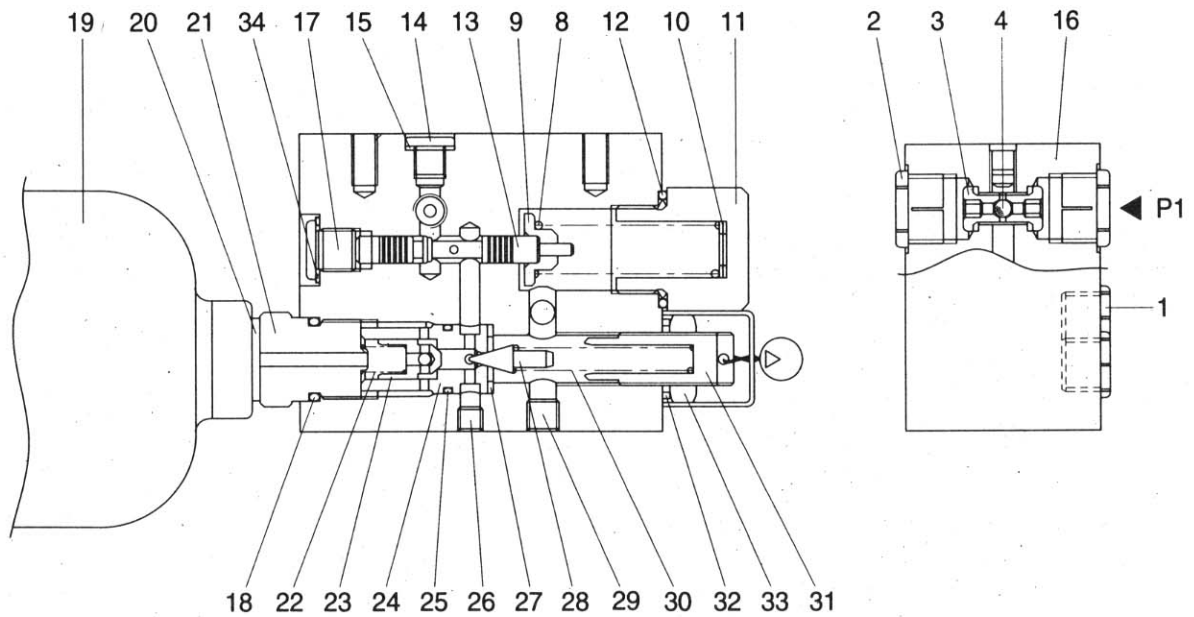

Pilot oil supply units are a combination of valves which reduce the pressure of medium and high pressure circuits in order to supply remote control valves with a low pressure supply of oil. They basically consist of the accumulator(19), the housing(16), a seat(3), a direct operated pressure relief valve(28) and a check valve(23).

Fluid flows from the high pressure via the shuttle valve(4) through port P1 into the unit and then to the secondary circuit. The pressure is reduced to the required level by means of spool(13) and passes via the check valve(23) into the accumulator(19) thus ensuring through port U greater control power and-when necessary-emergency operation should the main circuit be switched off or become defective.

Pressure relief valve(28) protects the pilot circuit should the spool(13) fail to operate. Check valve(23) prevents the accumulator emptying into the primary circuit.

Accumulator satisfies short term peak power demands and is a source of emergency power should the main circuit pressure fail.

## 7. SAFETY VALVE UNIT

### 1) STRUCTURE

The safety valve locks or permits pilot oil flow to the main control valve operation.

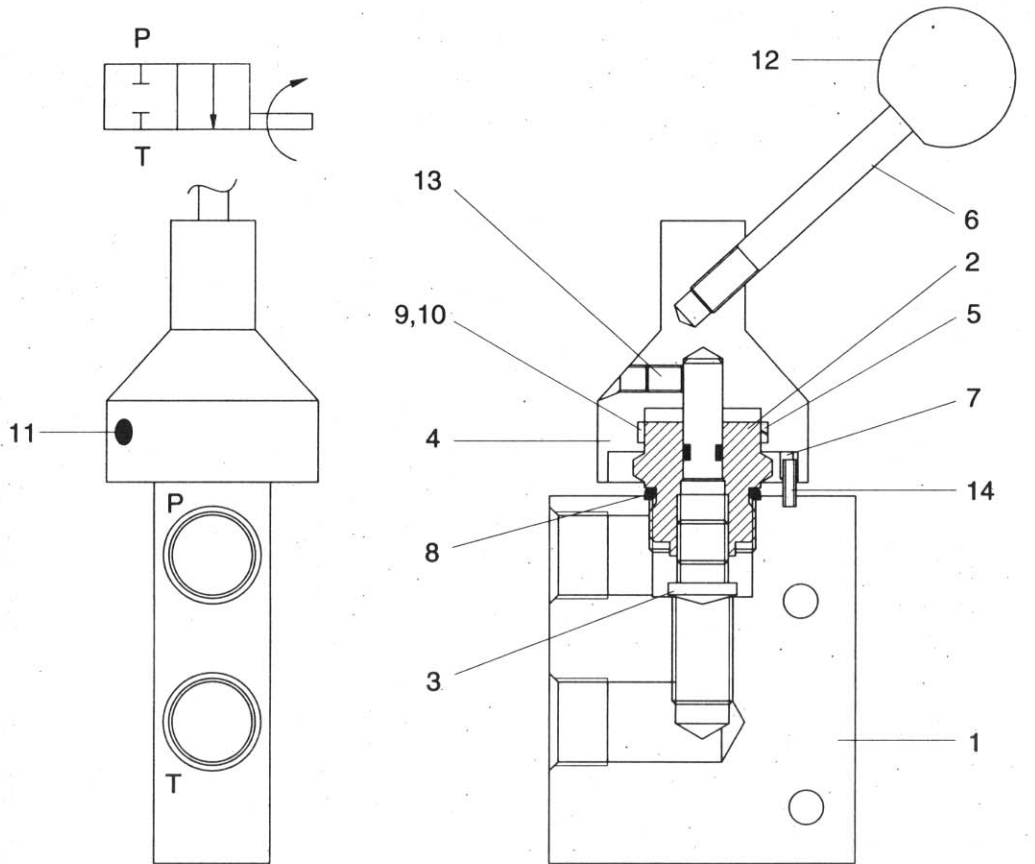

- |   |             |    |              |    |                  |
|---|-------------|----|--------------|----|------------------|
| 1 | Body        | 6  | Handle       | 11 | Spring plunger   |
| 2 | Retainer    | 7  | Spring pin   | 12 | Knob             |
| 3 | Adjust stem | 8  | O-ring       | 13 | Socket set screw |
| 4 | Housing     | 9  | O-ring       | 14 | Spring pin       |
| 5 | Clutch ring | 10 | Back up ring |    |                  |



## 8. BOOM AND BUCKET CYLINDER

The boom cylinders are two unit and the bucket cylinder is one unit. They use a bolt on rod guide.

The piston(12) threads on to the rod(2) and is retained by a nylon nut(18).

The piston seals against the tube(1) with glyd ring(15). Two wear rings(16) are located on each side of the piston seal.

The gland(3, the rod guide) seals against the tube with an O-ring(10). The cylinder thread seals against the rod with a lip type buffer ring(7) and a rod seal(5). A dust wiper(8) cleans the rod when it is retracted.

### 1) BOOM CYLINDER

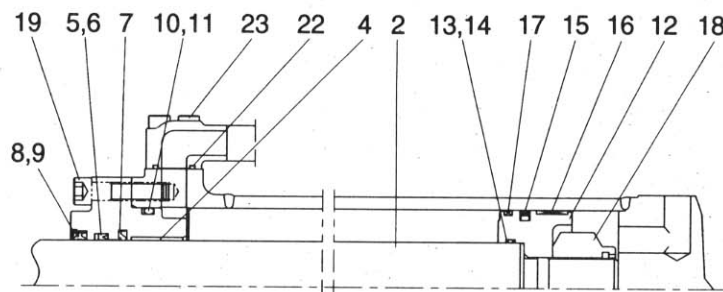
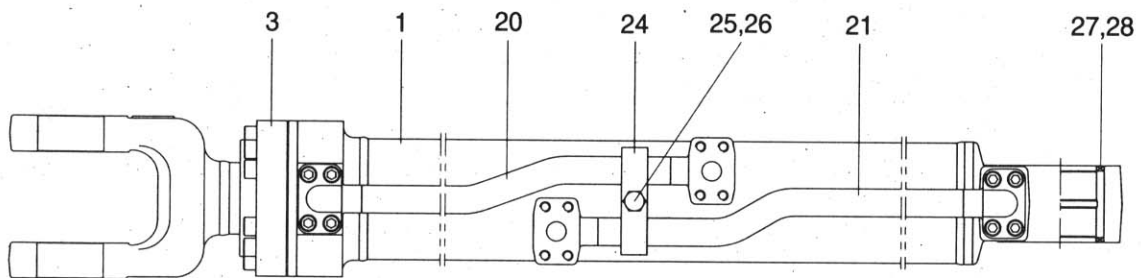

INTERNAL DETAIL

1	Tube assy	11	Back up ring	21	Pipe assy
2	Rod assy	12	Piston	22	O-ring
3	Gland	13	O-ring	23	Socket bolt
4	Bushing	14	Back up ring	24	Pipe clamp
5	Rod seal	15	Glyd ring	25	Hexagon bolt
6	Back up ring	16	Wear ring	26	Spring washer
7	Buffer ring	17	Dust ring	27	Bushing
8	Dust wiper	18	Nylon nut	28	Dust seal
9	Snap ring	19	Socket bolt		
10	O-ring	20	Pipe assy		

## 2) BUCKET CYLINDER

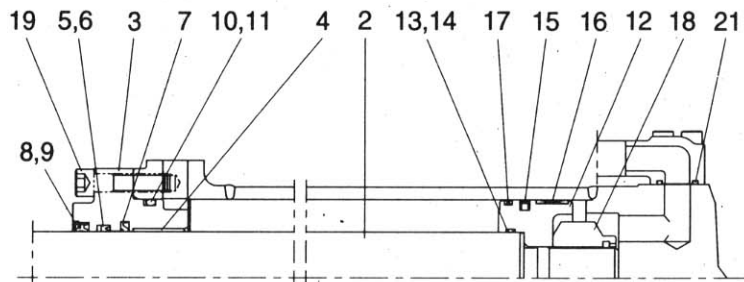
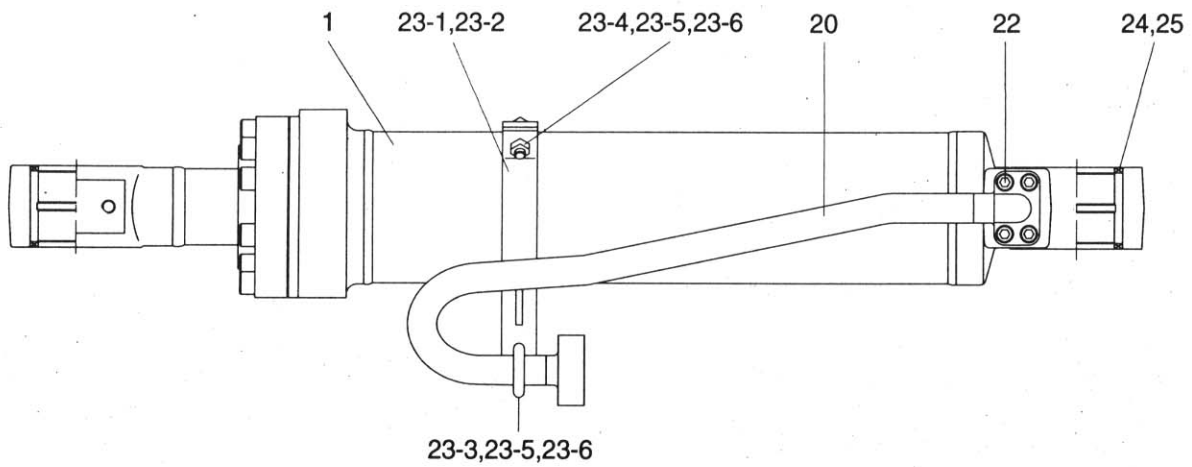

### INTERNAL DETAIL

1	Tube assy	12	Piston	23	Band assy
2	Rod assy	13	O-ring	23-1	Band sub assy
3	Gland	14	Back up ring	23-2	Band
4	Bushing	15	Piston seal	23-3	U-bolt
5	Rod seal	16	Wear ring	23-4	Hexagon bolt
6	Back up ring	17	Dust ring	23-5	Hexagon nut
7	Buffer ring	18	Nylon nut	23-6	Spring washer
8	Dust wiper	19	Socket bolt	24	Bushing
9	Snap ring	20	Pipe assy	25	Dust seal
10	O-ring	21	O-ring		
11	Back up ring	22	Socket bolt		

## 9. HYDRAULIC OIL TANK

### 1) STRUCTURE

- The oil from the hydraulic tank is sent from the pump through control valve to the cylinders. In the return circuit, the oil from various parts merges.
- A part of oil is cooled in the oil cooler(if equipped), passes through the hydraulic filter and returns to the hydraulic tank(1).
- If the hydraulic return oil filter becomes clogged, return filter bypass valve(9) acts to allow the oil to return directly to the hydraulic tank(1). This prevents damage to the hydraulic filter(8). The bypass valve(9) is also actuated when negative pressure is generated in the circuit.

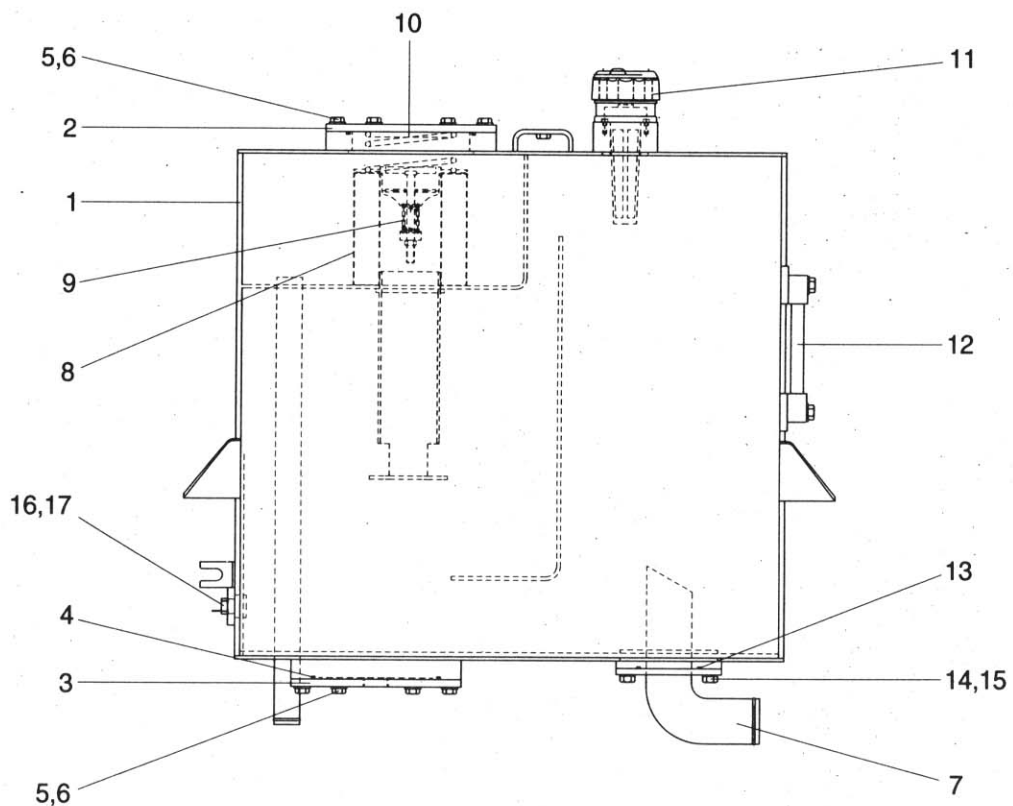

1	Hydraulic tank	7	Pipe	13	O-ring
2	Cover	8	Element	14	Bolt
3	Cover	9	Bypass valve	15	Hardened washer
4	O-ring	10	Spring	16	Overheat switch
5	Bolt	11	Air breather	17	O-ring
6	Hardened washer	12	Level gauge		

## 2) RETURN OIL FILTER BYPASS VALVE

### (1) When the filter is clogged

Bypass valve(1) is opened and the oil returns directly to the tank without passing through the filter.

Bypass valve set pressure : 1.36kgf/cm<sup>2</sup>  
(19.3psi)

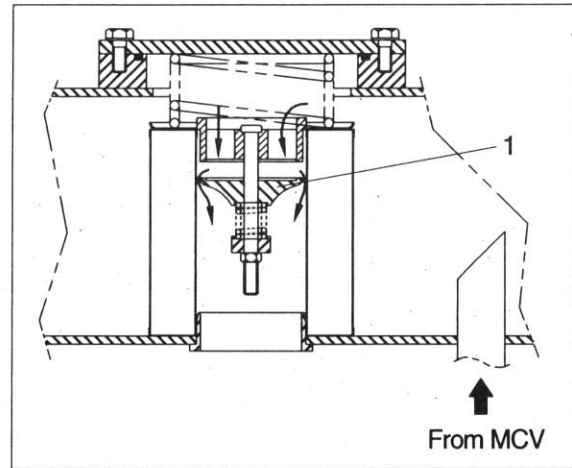

### 3) AIR BREATHER

The air breather is equipped with the capacity to perform three functions simultaneously-as an air filter, breathing valve, and as a lubrication opening.

#### (1) Preventing negative pressure inside the tank

The tank is a pressurized sealed type, so negative pressure is formed inside the hydraulic tank when the oil level drops during operations. When this happens, the difference in pressure between the tank and the outside atmospheric pressure opens the poppet in the breather, and air from the outside is let into the tank or prevent negative pressure.

#### (2) Preventing excessive pressure inside the tank

When the hydraulic cylinder is being used, the oil level in the hydraulic system increases and as temperature rises. If the hydraulic pressure rises above the set pressure, breather is actuated to release the hydraulic pressure inside the tank.

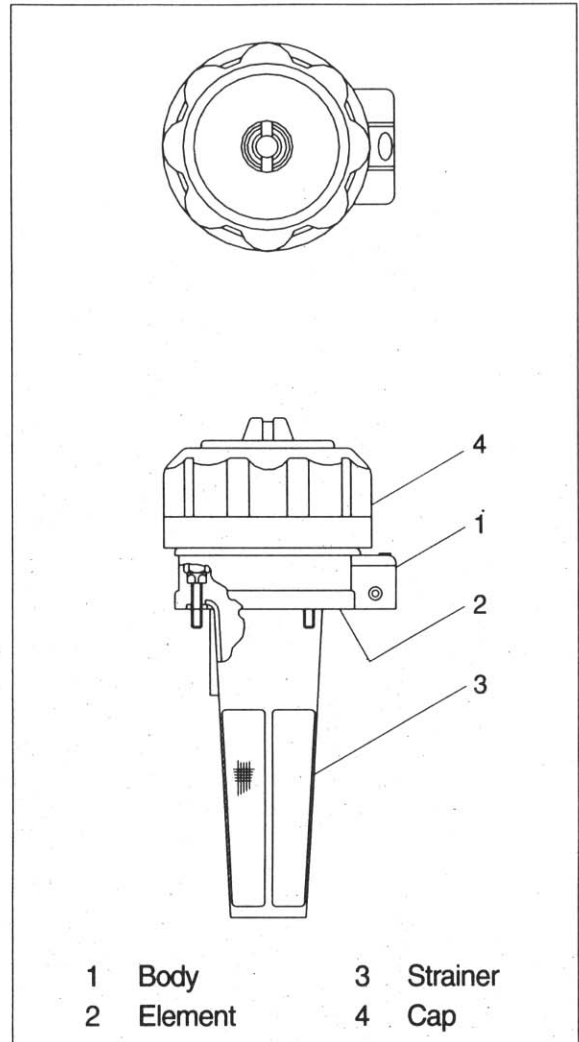

## 10. ACCUMULATOR

The accumulator is installed at the pilot oil supply unit. When the boom is left the raised position, and the control levers are operated with the engine stopped the pressure of the compressed nitrogen gas inside the accumulator sends pilot pressure to the control valve to actuate it and allow the boom and bucket to come down under their own weight.

Type of gas	Nitrogen gas(N <sub>2</sub> )
Volume of gas	0.75 l (0.2 U.S.gal)
Charging pressure of gas	16kgf/cm <sup>2</sup> (228psi)
Max actuating pressure	30kgf/cm <sup>2</sup> (427psi)

