

# SECTION 3 POWER TRAIN SYSTEM

## GROUP 1 STRUCTURE AND FUNCTION

### 1. POWER TRAIN COMPONENT OVERVIEW

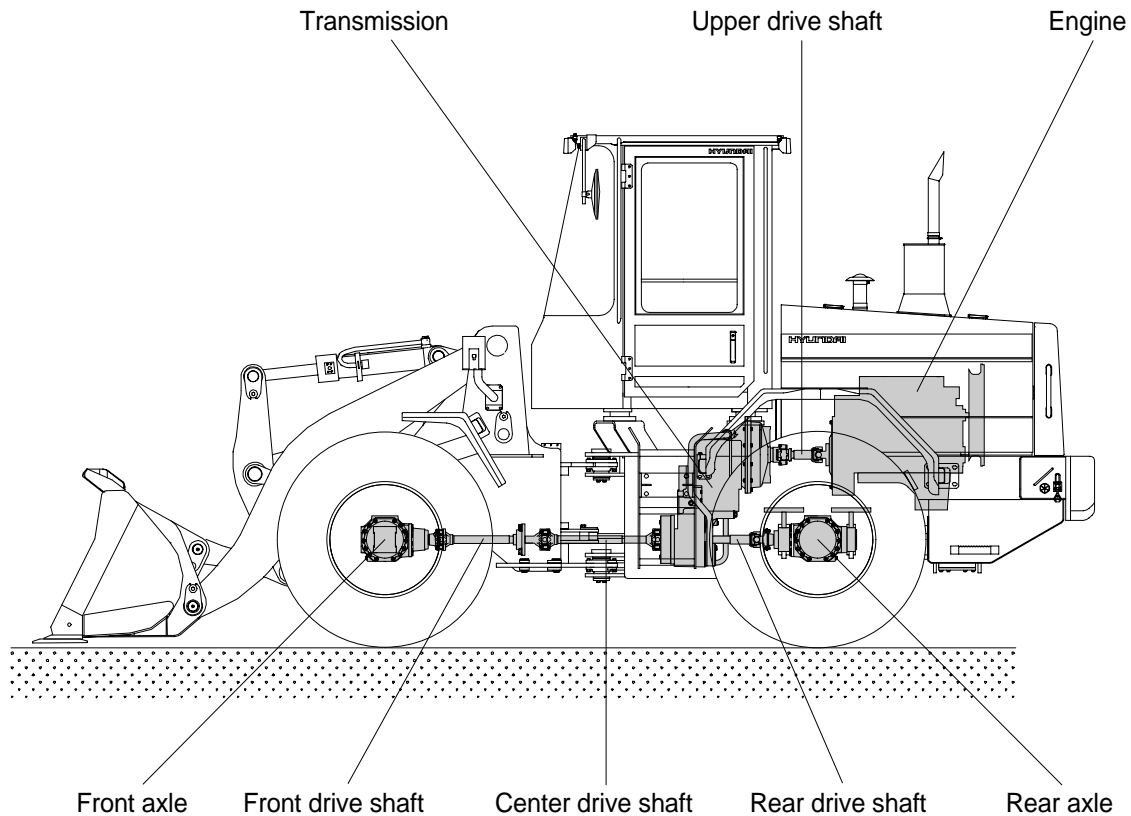

The power train consists of the following components :

- Transmission
- Front, upper, center and rear drive shafts
- Front and rear axles

Engine power is transmitted to the transmission through the upper drive shaft and the torque converter.

The transmission is a hydraulically engaged four speed forward, three speed reverse countershaft type power shift transmission. A drum type parking brake is located on the front of the transmission housing.

The transmission outputs through universal joints to three drive shaft assemblies. The front drive shaft is a telescoping shaft which drives the front axle. The front axle is mounted directly to the loader front frame. The front axle is equipped with limited slip differential.

The rear axle is mounted on an oscillating pivot. The rear axle is equipped with conventional differential.

The power transmitted to front axle and rear axle is reduced by the pinion gear and ring gear of differential. It then passes from the differential to the sun gear shaft(Axle shaft) of final drive.

The power of the sun gear is reduced by a planetary mechanism and is transmitted through the planetary hub to the wheel.

# HYDRAULIC CIRCUIT

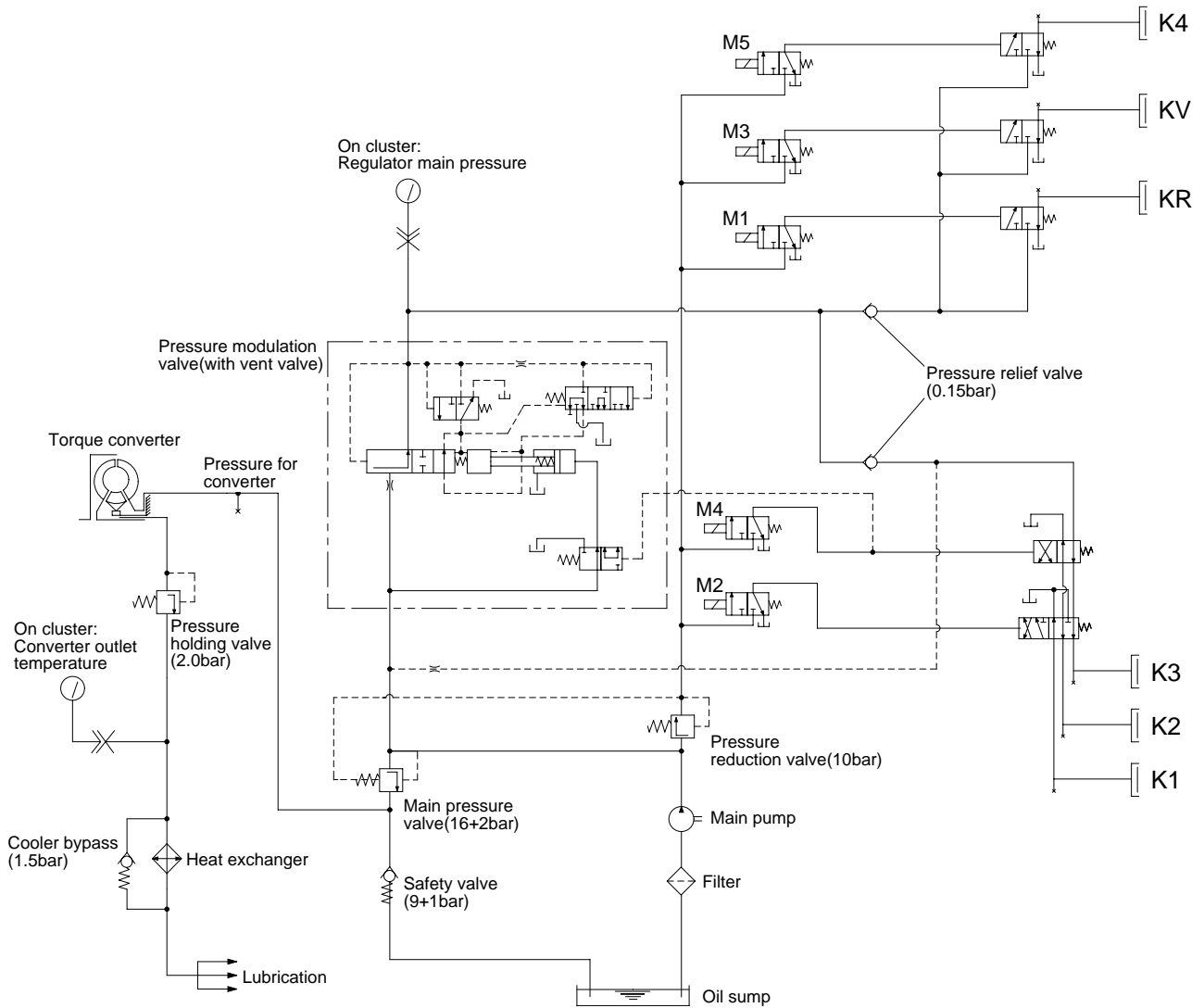

Speed	Forward				Reverse			Neutral
	1	2	3	4	1	2	3	
M1					X	X	X	
M2	X				X			
M3	X	X	X					
M4	X	X			X	X		
M5				X				

X : Solenoid engaged

## 2. TORQUE CONVERTER

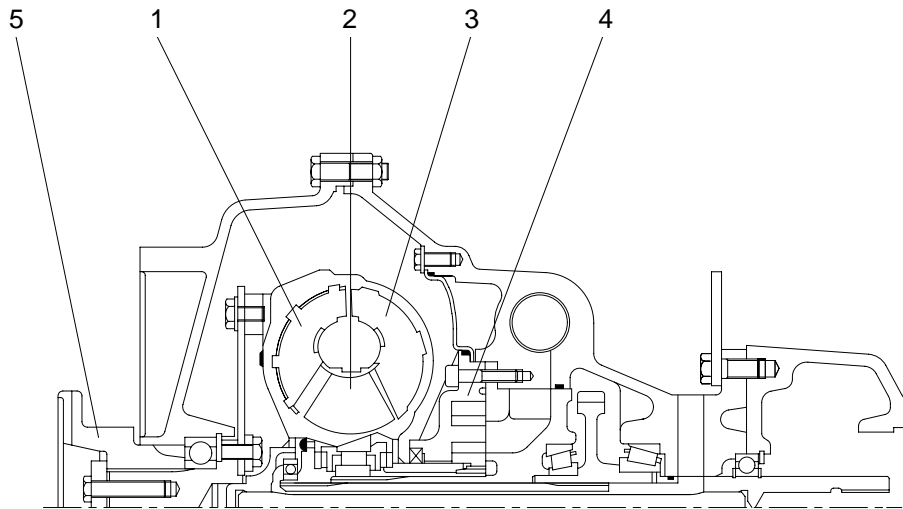

- |   |        |   |                   |   |              |
|---|--------|---|-------------------|---|--------------|
| 1 | Pump   | 3 | Turbine           | 5 | Input flange |
| 2 | Stator | 4 | Transmission pump |   |              |

The converter is working according to the Trilok-system, i.e. it assumes at high turbine speed the characteristics, and with it the favorable efficiency of a fluid clutch.

The converter will be defined according to the engine power so that the most favorable operating conditions for each installation case are given.

**The Torque converter is composed of 3 main components :**  
**Pump wheel - turbine wheel - stator(Reaction member)**

These 3 impeller wheels are arranged in such a ring-shape system that the fluid is streaming through the circuit components in the indicated order.

Pressure oil is constantly streaming out of the transmission pump through the converter. In this way, the converter can fulfill its task to multiply the torque of the engine, and at the same time, the heat created in the converter is dissipated through the escaping oil.

The oil, escaping out of the pump wheel, enters the turbine wheel and is there inverted in the direction of flow.

According to the rate of inversion, the turbine wheel and with it also the output shaft, receive a more or less high reaction moment. The stator(Reaction member), following the turbine, has the task to inverse again the oil which is escaping out of the turbine and to delivery it under the suitable discharge direction to the pump wheel.

Due to the inversion, the stator receives a reaction moment.

The relation turbine moment/pump moment is called torque conversion. This is the higher the greater the speed difference of pump wheel and turbine wheel will be.

Therefore, the maximum conversion is created at standing turbine wheel.

With increasing output speed, the torque conversion is decreasing. The adaption of the output speed to a certain required output moment is infinitely variable and automatically achieved by the torque converter.

If the turbine speed is reaching about 80% of the pump speed, the conversion becomes 1.0 i.e. the turbine moment becomes equal to that of the pump moment.

From this point on, the converter is working similar to a fluid clutch.

A stator freewheel serves to improve the efficiency in the upper driving range, it is backing up in the conversion range the moment upon the housing, and is released in the coupling range.

In this way, the stator can rotate freely.

**Function of a hydrodynamic torque converter(Schematic view)**

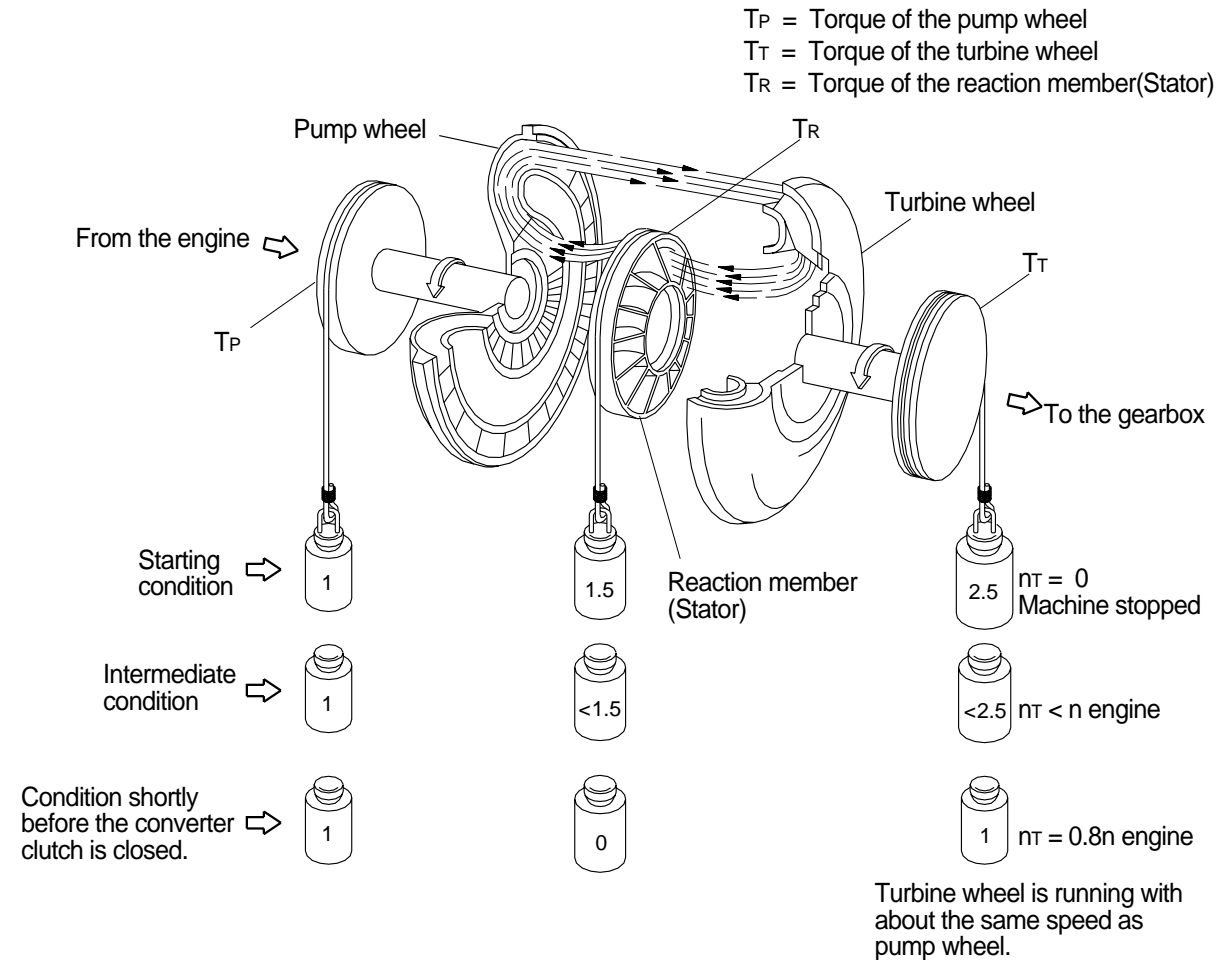

### 3. TRANSMISSION

#### 1) LAYOUT

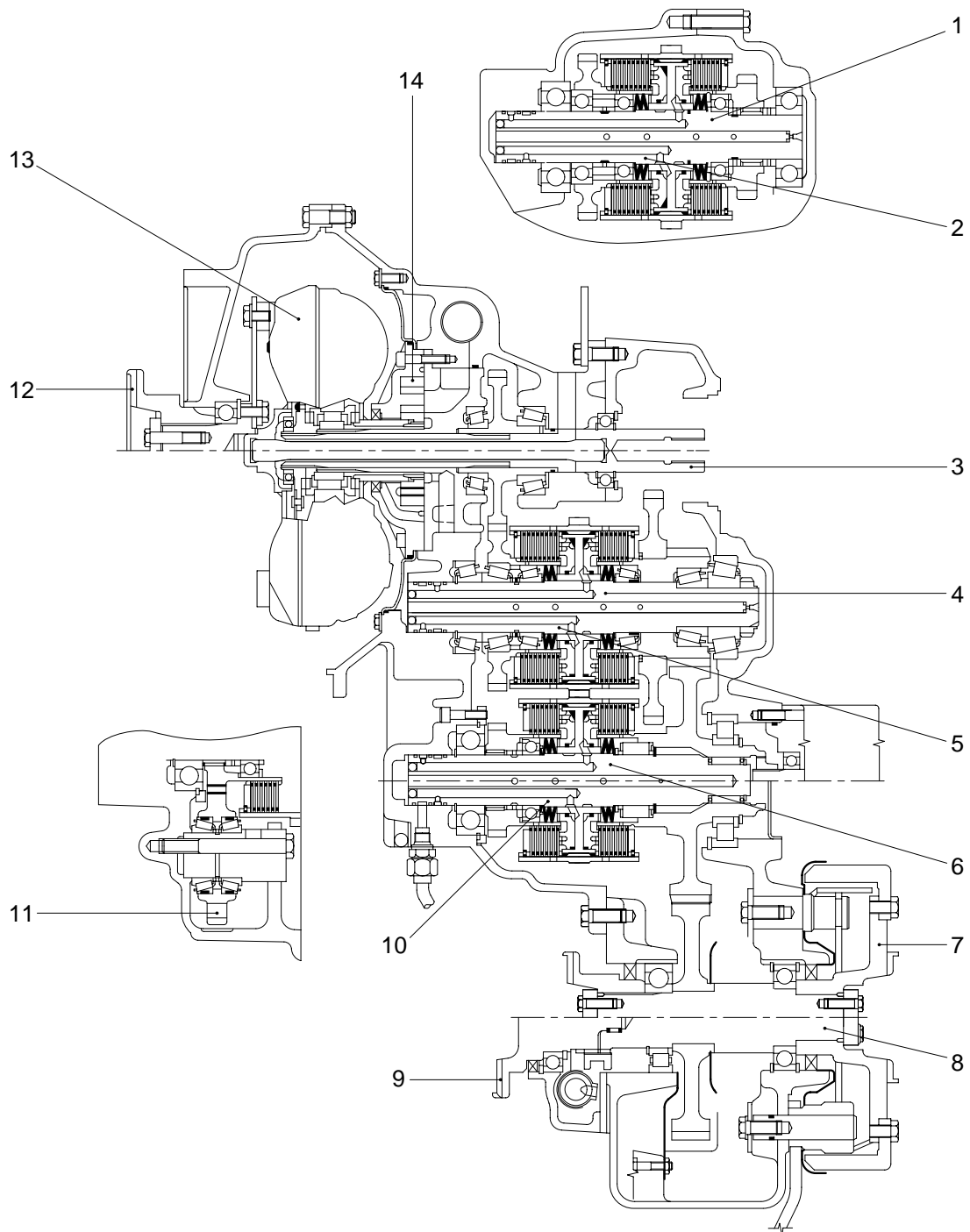

- |   |                                 |    |                              |
|---|---------------------------------|----|------------------------------|
| 1 | 1st clutch(K1)                  | 8  | Output shaft                 |
| 2 | Forward clutch(KV)              | 9  | Converter side output flange |
| 3 | Engine-dependent power take-off | 10 | 4th clutch(K4)               |
| 4 | 2nd clutch(K2)                  | 11 | Idler gear                   |
| 5 | Reverse clutch(KR)              | 12 | Input shaft                  |
| 6 | 3rd clutch(K3)                  | 13 | Converter                    |
| 7 | Parking brake                   | 14 | Transmission pump            |

## 2) INSTALLATION VIEW

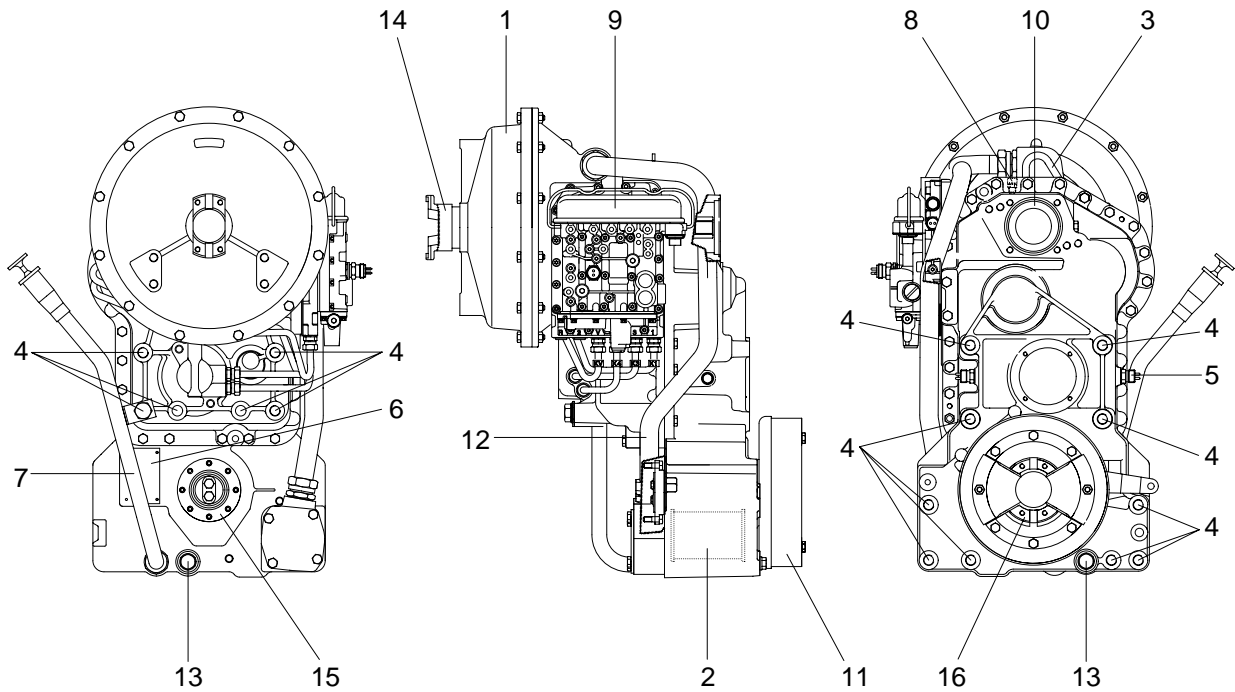

- |   |                                   |    |   |
|---|-----------------------------------|----|---|
| 1 | Converter                         | 9  | Electro-hydraulic shift unit            |
| 2 | Full flow filter                  | 10 | Power take-off;Coaxial;Engine-dependent |
| 3 | Fixing plate for assy             | 11 | Parking brake                           |
| 4 | Gearbox mounting pads             | 12 | Suction line                            |
| 5 | Inductive sensor-output speed     | 13 | Oil drain plug                          |
| 6 | Type plate                        | 14 | Input flange                            |
| 7 | Oil filler tube with oil dipstick | 15 | Output flange-converter side            |
| 8 | Breather                          | 16 | Output flange-rear side                 |

### 3) OPERATION OF TRANSMISSION

#### (1) Forward

##### ① Forward 1st

In 1st forward, FWD clutch and 1st clutch are engaged.

FWD clutch and 1st clutch are actuated by the hydraulic pressure applied to the clutch piston.

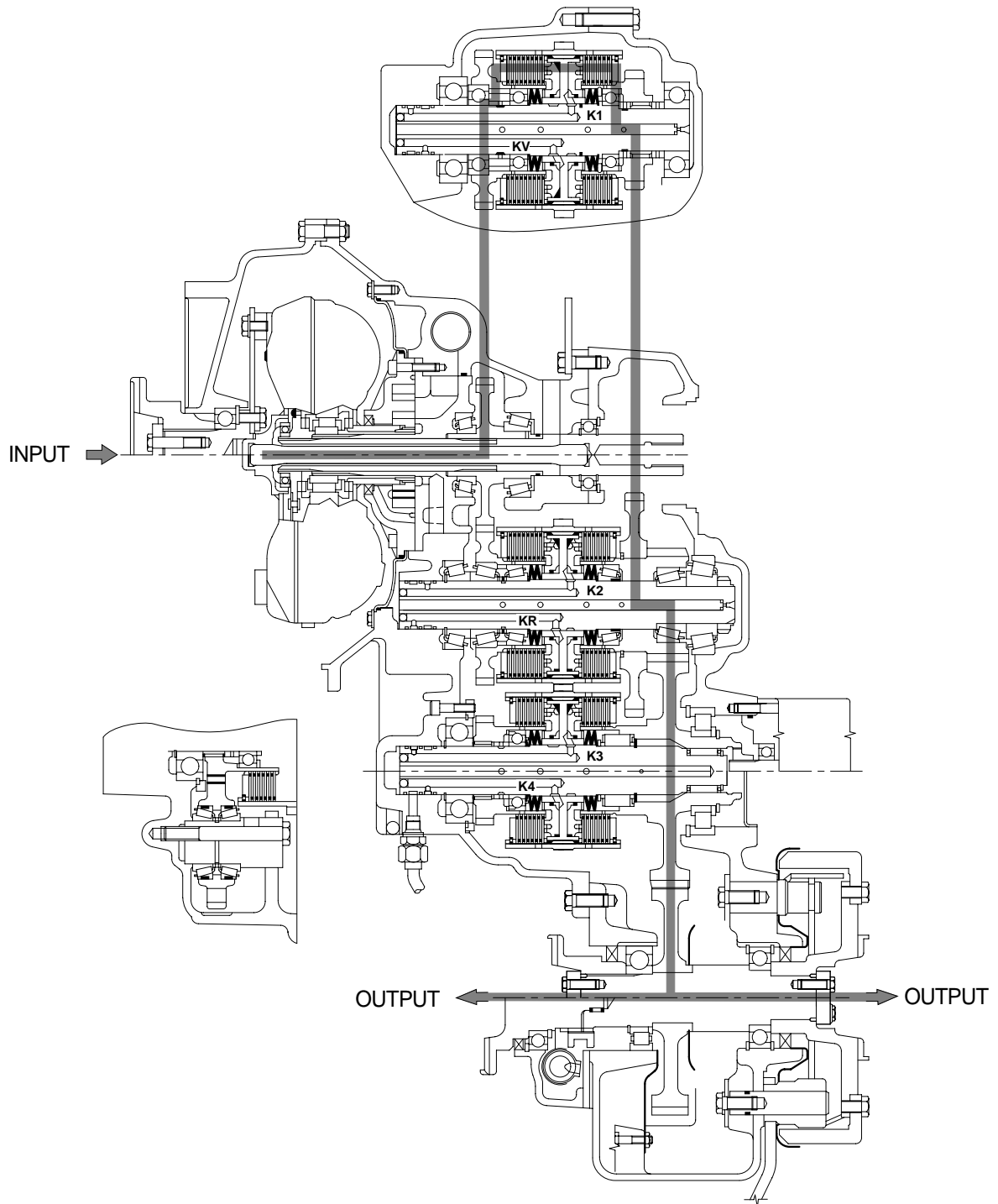

## ② Forward 2nd

In 2nd forward, FWD clutch and 2nd clutch are engaged.

FWD clutch and 2nd clutch are actuated by the hydraulic pressure applied to the clutch piston.

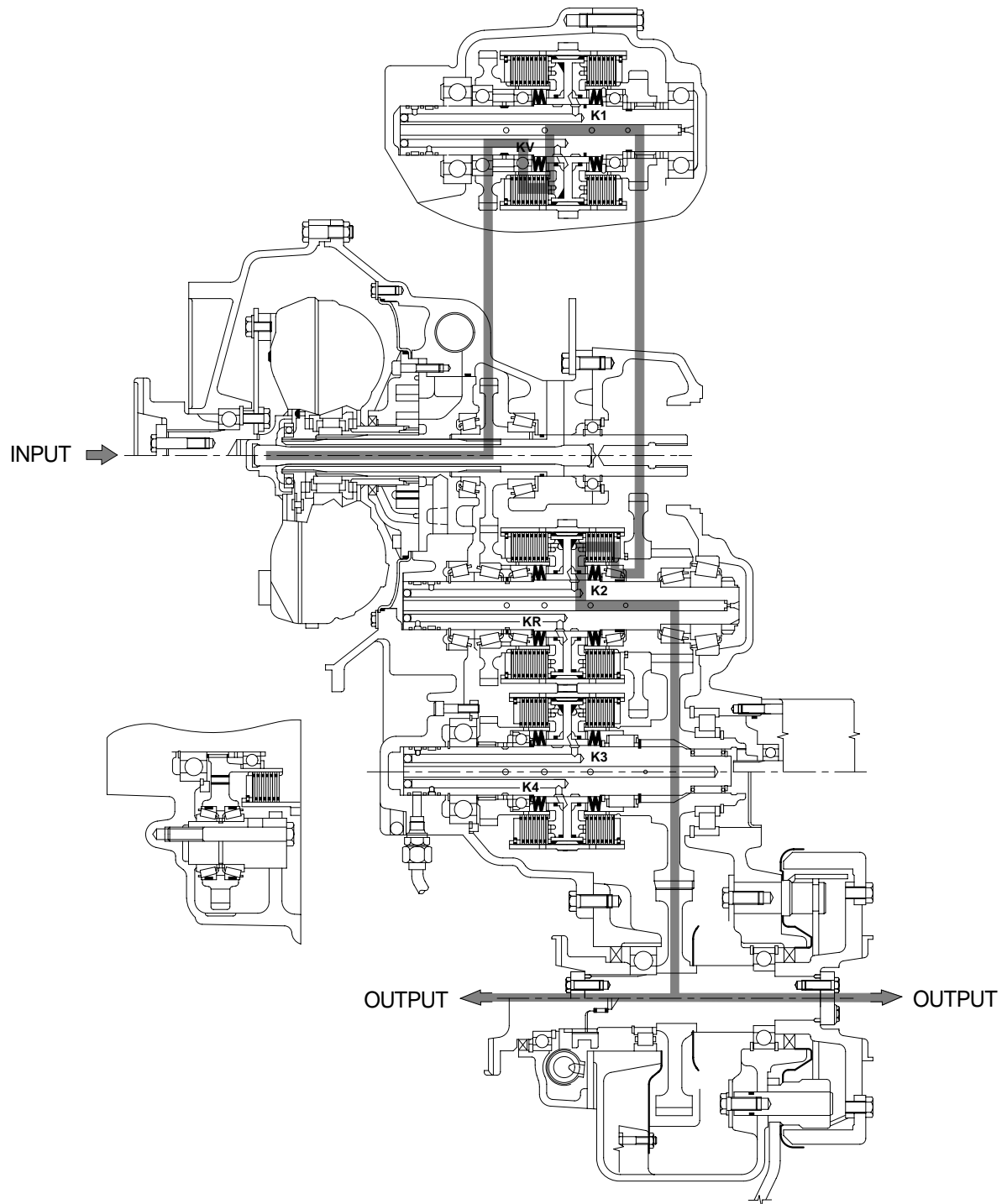



### ③ Forward 3rd

In 3rd forward, FWD clutch and 3rd clutch are engaged.

FWD clutch and 3rd clutch are actuated by the hydraulic pressure applied to the clutch piston.

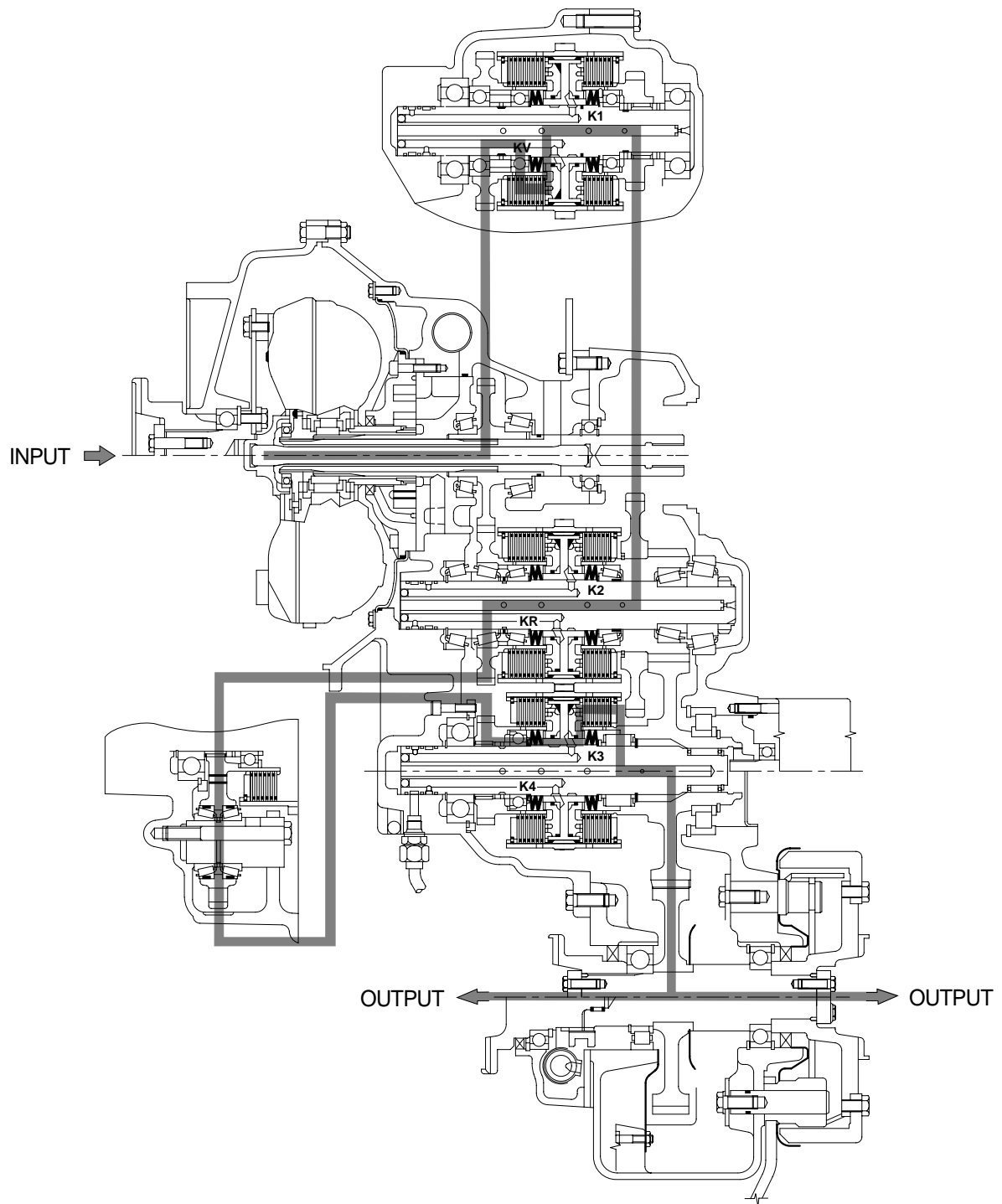

#### ④ Forward 4th

In 4th forward, 4th clutch and 3rd clutch are engaged.

4th clutch and 3rd clutch are actuated by the hydraulic pressure applied to the clutch piston.

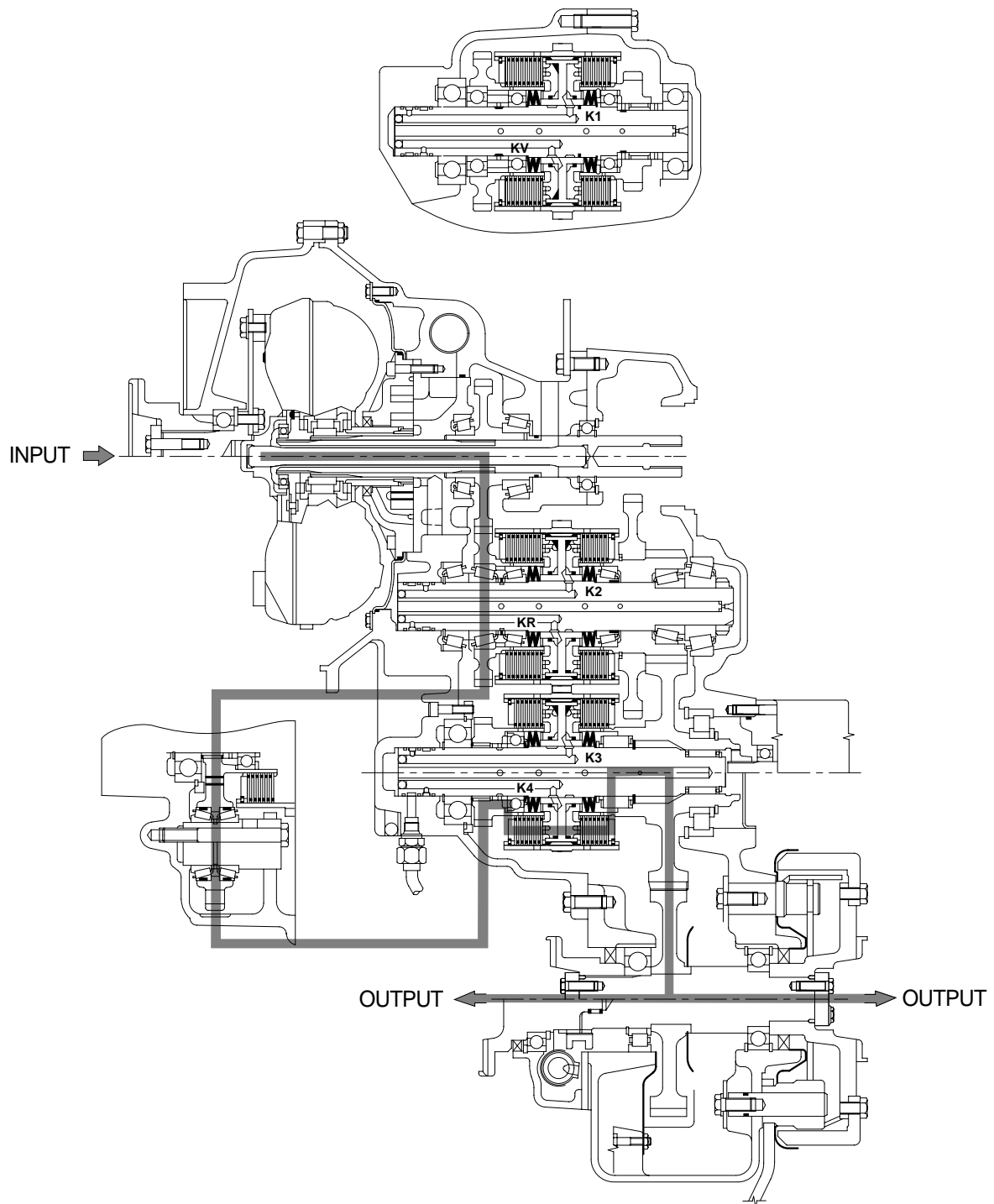

## (2) Reverse

### ① Reverse 1st

In 1st reverse, REV clutch and 1st clutch are engaged.

REV clutch and 1st clutch are actuated by the hydraulic pressure applied to the clutch piston.

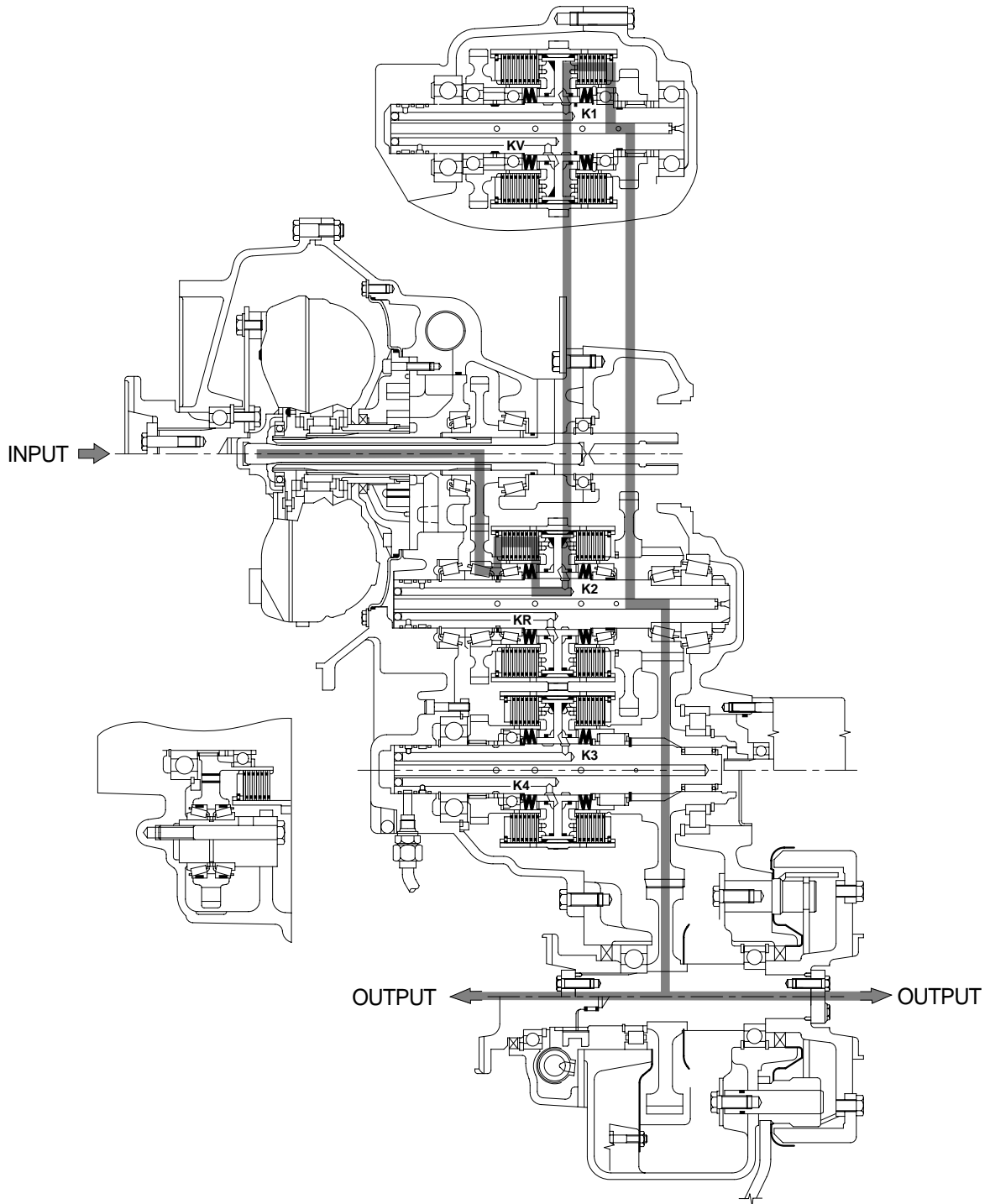

② Reverse 2nd

In 2nd reverse, REV clutch and 2nd clutch are engaged.

REV clutch and 2nd clutch are actuated by the hydraulic pressure applied to the clutch piston.

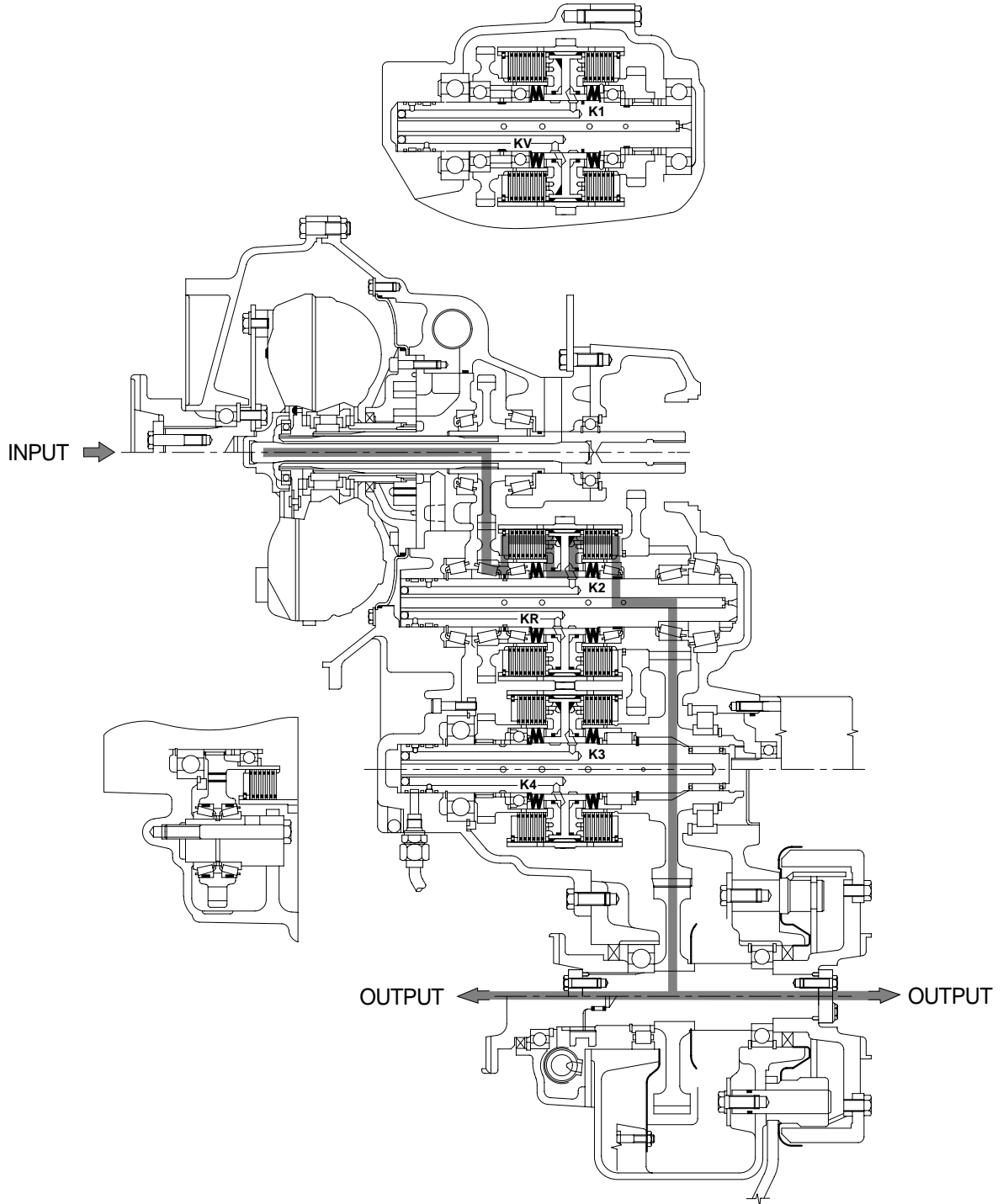

③ Reverse 3rd

In 3rd reverse, REV clutch and 3rd clutch are engaged.

REV clutch and 3rd clutch are actuated by the hydraulic pressure applied to the clutch piston.

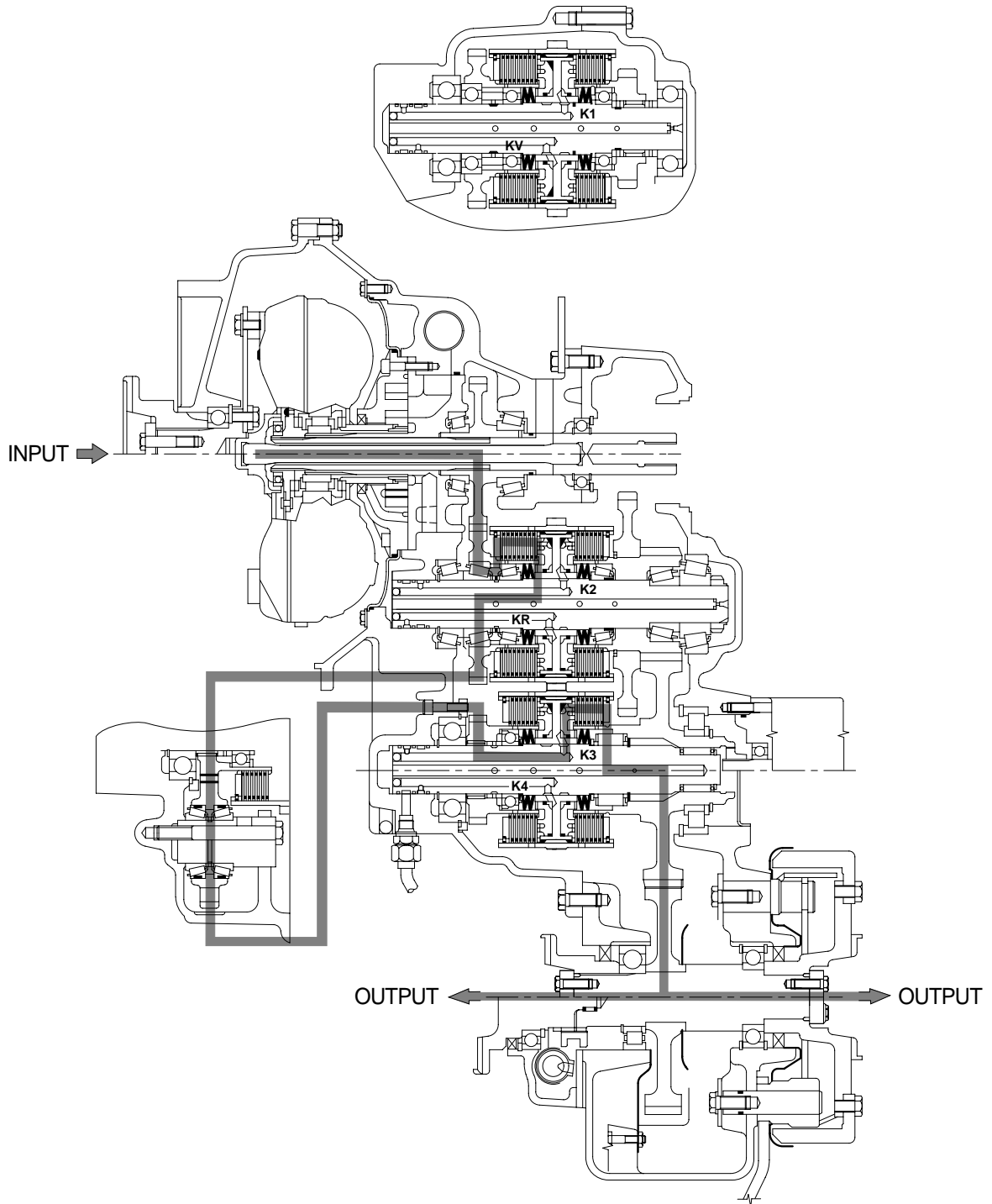

#### 4) ELECTRO-HYDRAULIC SHIFT UNIT

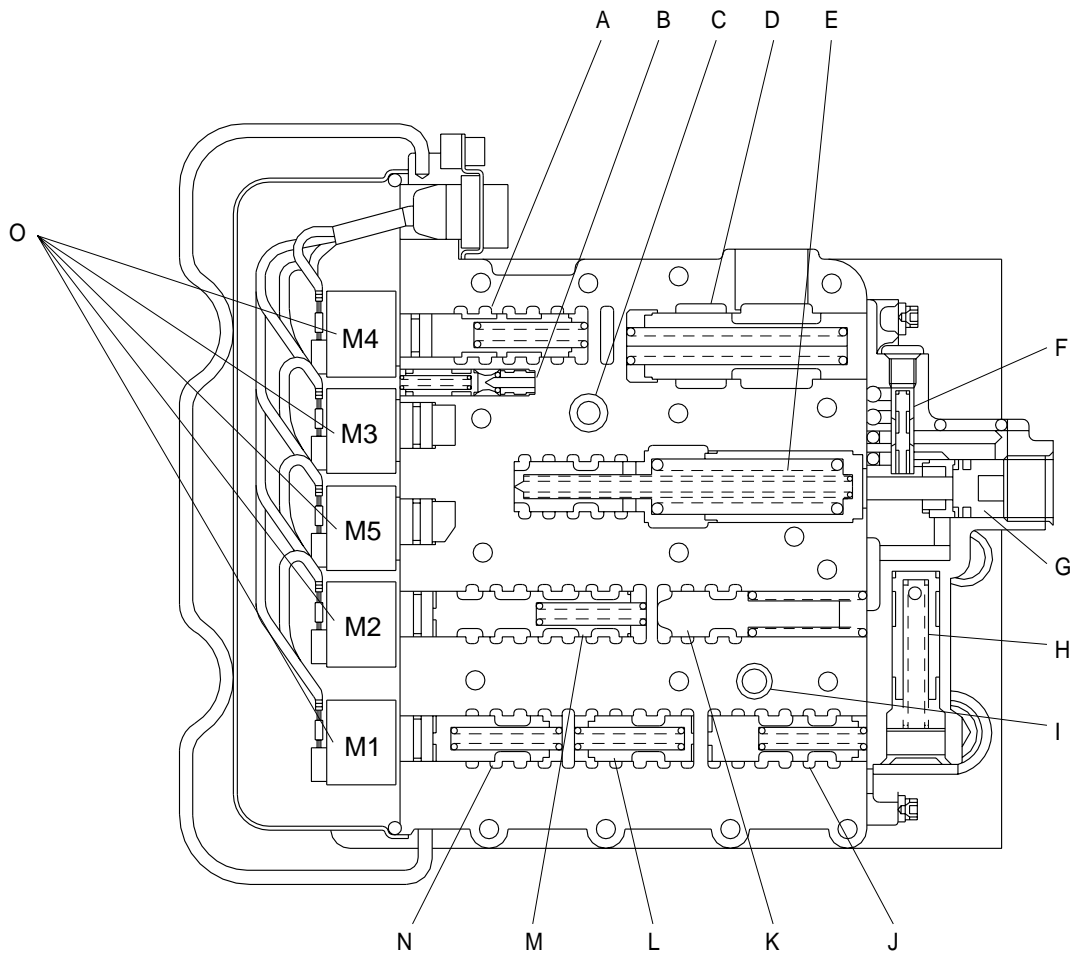

- |   |                                    |   |                     |   |                     |
|---|------------------------------------|---|---------------------|---|---------------------|
| A | First and second shift valve       | F | Pilot valve         | K | Reset valve         |
| B | Solenoid pressure regulating valve | G | Two-stage piston    | L | Fourth shift valve  |
| C | Check valve                        | H | Vent valve          | M | First shift valve   |
| D | Pressure reducing valve            | I | Check valve         | N | Reverse shift valve |
| E | Modulation valve                   | J | Forward shift valve | O | Solenoid valve      |

- (1) The transmission control valve assembly regulates the hydraulic control circuit of the transmission. The control valve receives electrical signals from the main controller to energize the solenoids which direct oil to move the shift valves. When the shift valves move, oil pressure drops to start modulation and fill the oncoming clutch pack.
- (2) There are four gaskets and three plates between the transmission control valve and the housing. Two plates are used to orifice oil to valves. The middle plate(Duct plate) is used to route oil from the solenoids to the valves and then thru the hoses to transmission shafts. The main valve contains pressure regulating valves, solenoid valves, shift valves, and valves for modulation.
- (3) The pressure reducing valve(D) is a spring-loaded spool valve which regulates main pressure oil by controlling flow into the control circuit. Excess oil from the control circuit flows to the torque converter.
- (4) Main pressure oil flows to the solenoid pressure regulating valve(B). The regulating valve provides a constant oil pressure to the solenoids and is not affected by modulation. The five solenoid valves(M) direct oil to the shift valves to provide machine direction and speed selection.
  - M1 Solenoid valve engages reverse shift valve(N).
  - M2 Solenoid valve engages first shift valve(M).
  - M3 Solenoid valve engages forward shift valve(J).
  - M4 Solenoid valve engages first, second shift valve(A).
  - M5 Solenoid valve engages fourth shift valve(L).
- (5) The pressure regulating valve supplies a regulated pressure oil through a plate orifice to the modulation valve(E). The modulation valve is a spring-loaded valve which controls the speed of clutch engagement during a shift.
- (6) When the first speed clutch is engaged, oil routed to the clutch pack also flows to the pilot valve (F). The pilot valve, which is a spring-loaded shuttle valve, moves and blocks passage to the two-stage piston(G). The two-stage piston is a stepping piston used to preload the modulation valve springs to start clutch modulation at a higher pressure. In first speed, modulation starts at a lower pressure to result in a less aggressive shift. In all other speeds, main pressure flows through the pilot valve to the two-stage piston and preloads the modulation valve resulting in a higher starting pressure.
- (7) As modulation ends, the reset valve(K), which is a spring-loaded spool valve, moves and opens a direct path through the modulation valve for fast clutch engagement.
- (8) Two clutches have to be engaged for the machine to move. One from the directional clutch packs either forward, reverse, or fourth. One from the speed clutch packs either first, second, or third. Check valves(C and I) are used to prevent flow between a directional shift and a speed shift. These check valves prevent a drop in clutch pack pressure in the engaged clutch.

## 5) SPEED CONTROL FUNCTIONAL DESCRIPTION

### (1) Complete system

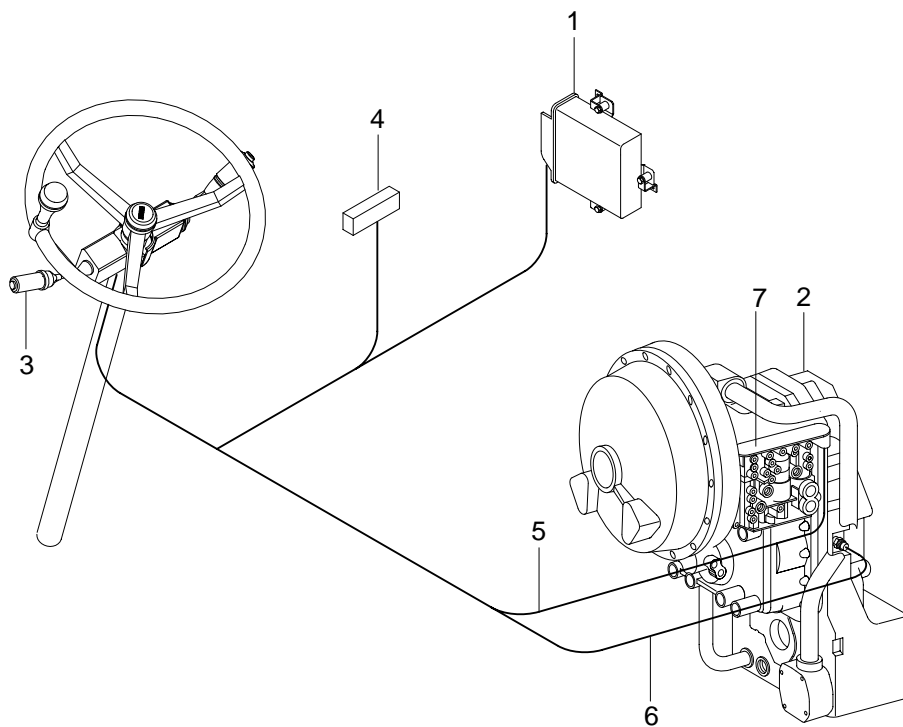

1 Transmission control unit  
2 Transmission  
3 Gear selector

4 Battery  
5 Control valves cable

6 Inductive sensor output cable  
7 Electro-hydraulic shift unit



## (2) Description of basic functions

A specific speed range selector concept has been developed for use in wheel loaders equipped with electro-hydraulically controlled power shift transmission, it incorporates the speed range selector(DW-2) and micro-processor control unit(EST-17T).

This system processes all driver's instructions, such as direction of travel, selected gear as well as the current machine speed and offers the following significant advantages:

- ① High adaptability to engine, machine and operation conditions through specific programming.
- ② Reversing possibility through all gears.
- ③ Easy KD function(**Semi-automatic**).
- ④ Waterproof, compact range selector with integrated KD button and neutral position interlock, without any other active interlocks.
- ⑤ Short circuit proof and overvoltage protected electrical system.
- ⑥ Many safety features to protect against operating errors(Software).

## (3) Block circuit diagram for micro-processor control unit(EST-17T)

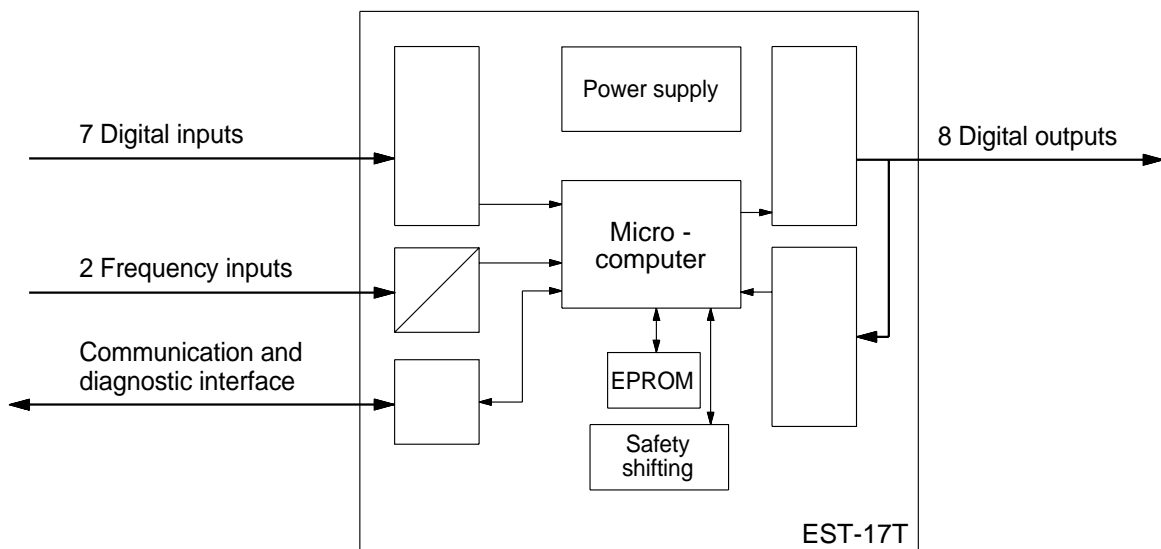

#### (4) Component description

##### ① Gear(speed) selector

The gear selector has been designed for attachment to left of steering column. Positions(Gears) 1-4 are selected by turning, whereas the direction of travel is selected by shifting the lever(Forward (V) - Neutral (N) - Reverse (R)). On transmission with 3 reverse speeds only the gear 3R is selected on gear position 4R.

A neutral position interlock protects against unintentional machine movements during start-up. Lever position D : Drive ; Position N : Shift lever is locked in NEUTRAL position.

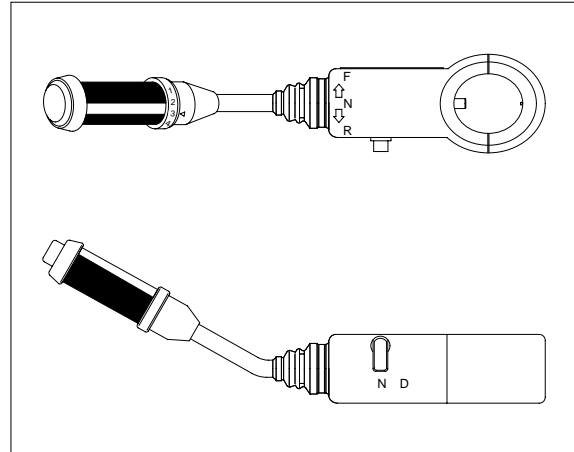

##### ② Micro processor control unit

###### A. General

The short-circuit-proof and overvoltage-protected control unit must be installed in a protected place in the driver's cab. via the by-packed buffers.

The control unit with inserted plug is splash-waterproof.

###### B. Direct control of solenoid valves

The solenoids of the electro-hydraulic control block at the transmission are directly controlled by the electronics, i.e. without relays. Therefore, in normal practice just the outputs for the starter interlock and reverse lights must be relay-controlled.

###### C. Gear selection

When ignition is turned on, the electronics remain in stand-by position and are ready for operation when the lever is shifted into NEUTRAL position. Thereupon the gear can be selected.

In general, the following applies for gear selection from NEUTRAL position : If road speed is too high for the preselected gear(Risk of overrevving), it is necessary to downshift to the lowest permissible gear and then continue down-shifting in steps of 2.5 seconds until the preselected gear is reached.

###### D. Kick down function

In gear positions 2V or 2R the 1st gear can be selected any time through slightly pushing the KD button which is integrated in the shift lever. At proper road speed(Approx 95% of max speed of 1st gear) up-shifting to the 2nd gear is performed automatically, however, not before 2.5 seconds.

This KD function remains in force also during reverse shifting, unless shift lever remains in NEUTRAL position not longer than 1 second.

### **E. Passive reversing interlock**

Since the gear selector DW-2 has no active reversing interlock, reversing is possible at any time. Depending on current road speed resulting in :

- Direct reversing is possible at any time in gears 1 and 2(1V  $\leftarrow$   $\rightarrow$  1R and 2V  $\leftarrow$   $\rightarrow$  2R).
- The sequence of road-speed-dependent reversing in gears 3 and 4 is as follows :
  - Beyond a programmed speed limit(Normally the max speed of the 2nd gear) reversing is performed via an immediate down-shift to the 2nd gear of the current direction of travel, a shuttle-shift to the 2nd gear of the reverse direction of travel for 1.2 seconds, and finally up-shifts to the preselected gear in steps of 2.5 seconds.
    - If speed drops below limit speed, reversing is performed immediately.
  - Below this speed limit, reversing is performed directly, i.e. without prior down-shifts.

### **F. Up - shifts**

If preselected gear is more than 2 gear steps beyond the currently selected gear, up-shifting is performed in steps of 2.5 seconds.

### **G. Down - shifts**

Down - shifts to the 2nd gear are performed immediately, even if gears are being skipped.

If 1st gear is to be selected from either the 3rd or 4th gear, it is necessary to first down - shift to the 2nd gear for 1.2 seconds, and then continue to the 1st gear.

### **H. Pressure cut - off**

The pressure cut - off device in the 1st and 2nd gear forward and reverse is activated by an external positive signal(+). The transmission power-flow is interrupted as long as this positive signal is being transmitted.

### **I. Cross shifts**

If within the locking period of 1.2 seconds not only down but also reverse shifts are performed, the transmission shifts to Neutral position till the end of this interval(Counted from the first selected shifting point).

### **J. Direct solenoid control in NEUTRAL position**

With the gear selector lever in NEUTRAL position certain transmission-specific solenoid combinations are signalled for gear positions 1 and 2. These signals will be eliminated as soon as max speed of 2nd gear is exceeded.

### **K. Detection of inductive sensor failure**

The road speed is determined via the inductive sensor at the output side. Its failure will also be assumed at a vehicle stand-still for longer than 10 seconds, although the 3rd or 4th gear is engaged.

If the electronics have determined an inductive sensor failure, up-shifts beyond the 2nd gear are not possible and from the 3rd and 4th gear, down-shifts can be performed only. Moreover, reverse shifts from the 3rd or 4th gear are only possible to the 2nd gear in the reverse direction of travel. The status inductive sensor failure will be eliminated as soon as the inductive sensor signal can be sensed again. In this case, there is no automatic up-shifting to the preselected higher gear(See L).

#### **L. System performance in case of faults**

The control unit constantly controls all inputs of the range selector as well as all outputs to the solenoid valves. In case of inadmissible combinations(e.g. cable break, stray signals) the electronics shift immediately to neutral condition and lock all outputs.

The same applies, if certain voltage limits are exceeded or in case of short-circuit.

This lock can be eliminated by shifting the range shift lever through the NEUTRAL position.

The same applies for the up-shift interlock after inductive sensor failure.

In case of repeated faults, it is imperative to check the machine's electrical circuit and to exchange defective components immediately.

#### **M. Wiring**

All cable connections for solenoid valves, inductive sensor, speed range selector, electronics and machine's electrical circuit are integrated in the compact wiring harness avoiding the individual wiring.

This compact wiring harness is available from production in different lengths.

- ※ **A wiring system of single cables is available for prototype units in order to simplify necessary modifications.**



## 2) SECTION OF FRONT AXLE DIFFERENTIAL

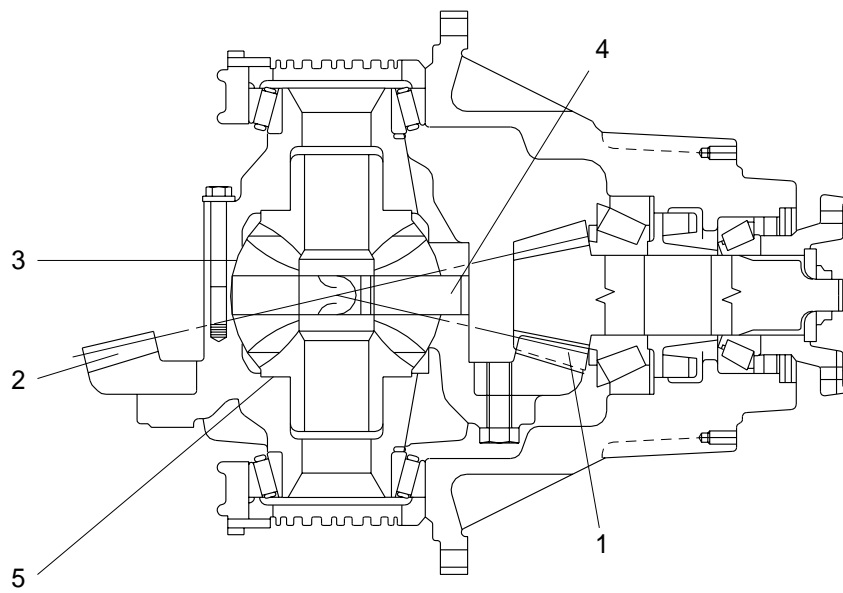
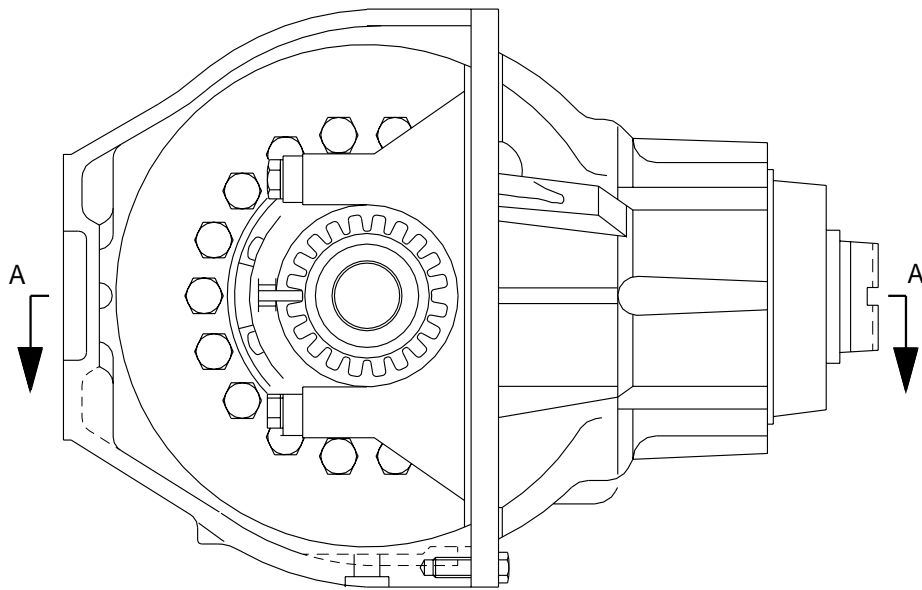

SECTION A-A

- |   |              |   |           |   |                         |
|---|--------------|---|-----------|---|-------------------------|
| 1 | Bevel pinion | 3 | Sun gears | 5 | Side gear(Differential) |
| 2 | Bevel gear   | 4 | Shaft     |   |                         |

### 3) SECTION OF REAR AXLE DIFFERENTIAL

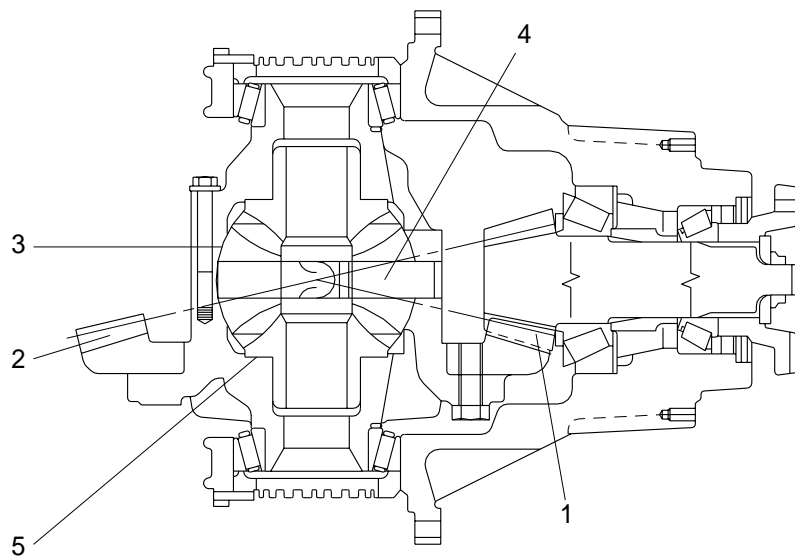
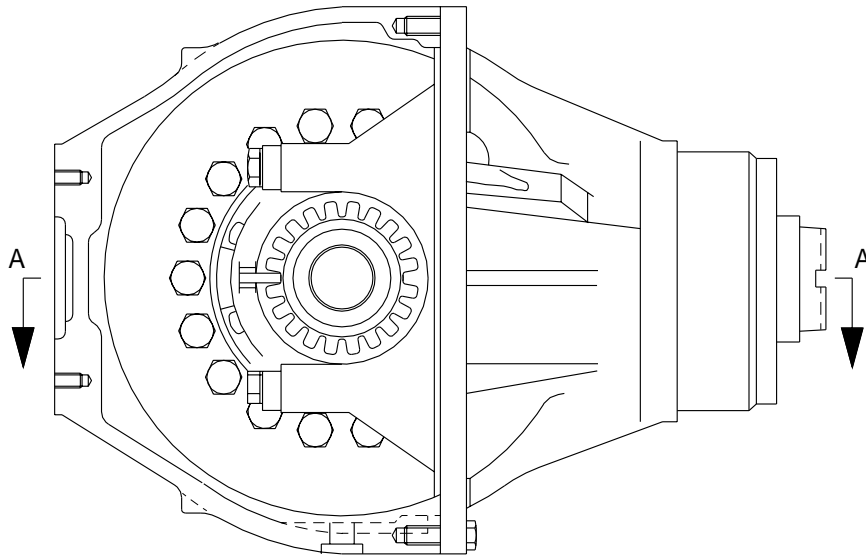

SECTION A-A

- |   |              |   |           |   |                         |
|---|--------------|---|-----------|---|-------------------------|
| 1 | Bevel pinion | 3 | Sun gears | 5 | Side gear(Differential) |
| 2 | Bevel gear   | 4 | Shaft     |   |                         |

#### 4) DIFFERENTIAL

##### (1) Description

When the machine makes a turn, the outside wheel must rotate faster than the inside wheel. A differential is a device which continuously transmits power to the right and left wheels while allowing them to turn at different speeds, during a turn.

The power from the drive shaft passes through bevel pinion(1) and is transmitted to the bevel gear(2). The bevel gear changes the direction of the motive force by 90 degree, and at the same time reduces the speed.

It then transmits the motive force through the differential(3) to the axle gear shaft(4).

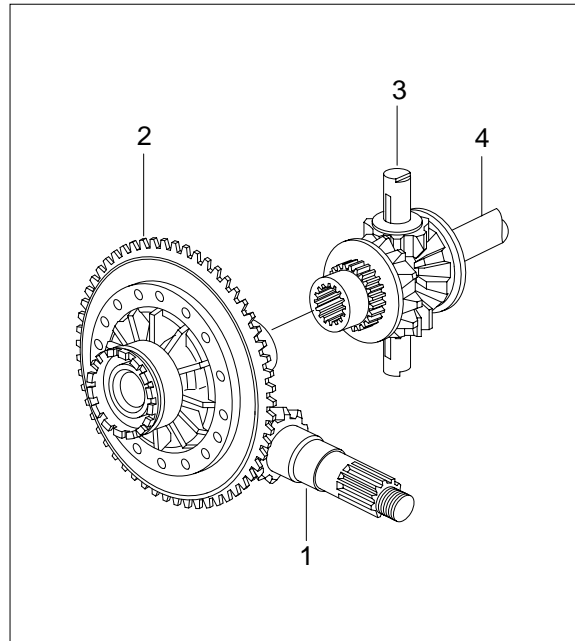

##### (2) When driving straight forward

When the machine is being driven straight forward and the right and left wheels are rotating at the same speed, so the pinion gear inside the differential assembly do not rotate. The motive force of the carrier is sent through the pinion gear and the side gear, therefore the power is equally transmitted to the left and right axle gear shaft.

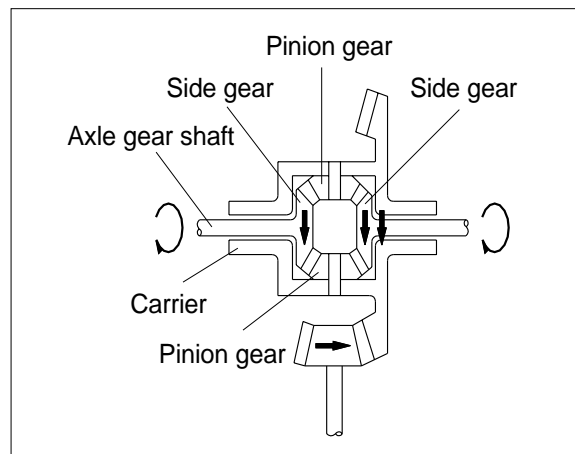

##### (3) When turning

When turning, the rotating speed of the left and right wheels is different, so the pinion gear and side gear inside the differential assembly rotate in accordance with the difference between the rotating speed of the left and right wheels.

The power of the carrier is then transmitted to the axle gear shafts.

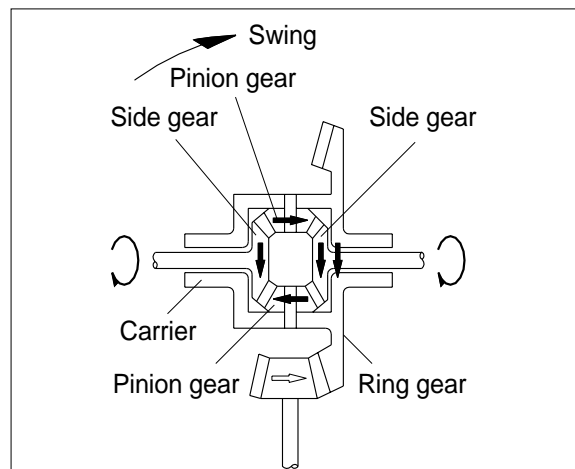



## 5) TORQUE PROPORTIONING DIFFERENTIAL

### (1) Function

① Because of the nature of their work, 4-wheel-drive loaders have to work in places where the road surface is bad.

In such places, if the tires slip, the ability to work as a loader is reduced, and also the life of the tire is reduced.

The torque proportioning differential is installed to overcome this problem.

In structure it resembles the differential of an automobile, but the differential pinion gear has an odd number of teeth.

Because of the difference in the resistance from the road surface, the position of meshing of the pinion gear and side gear changes, and this changes the traction of the left and right tires.

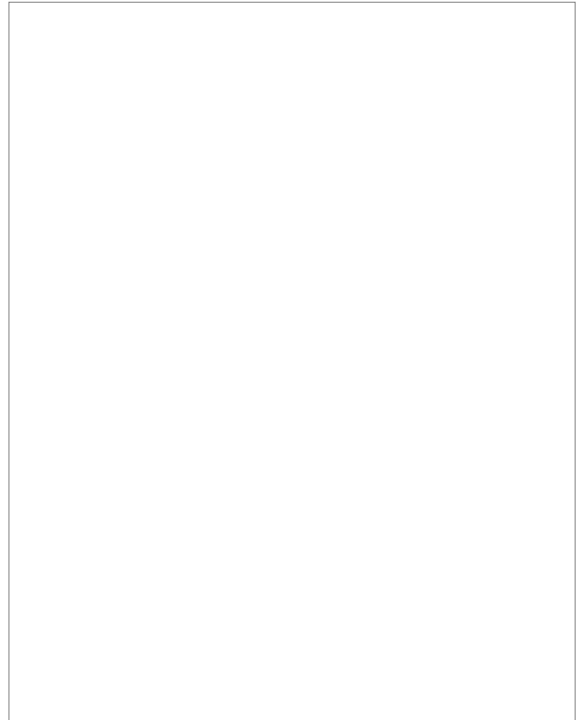

### (2) Operation

① **When traveling straight**(Equal resistance from road surface to left and right tires)

Under this condition, the distances involving the engaging points between right and left side gears and pinion-a and b-are equal and the pinion is balanced as  $FL \times a = FR \times b$ . Thus,  $FL = FR$ , and the right and left side gears are driven with the same force.

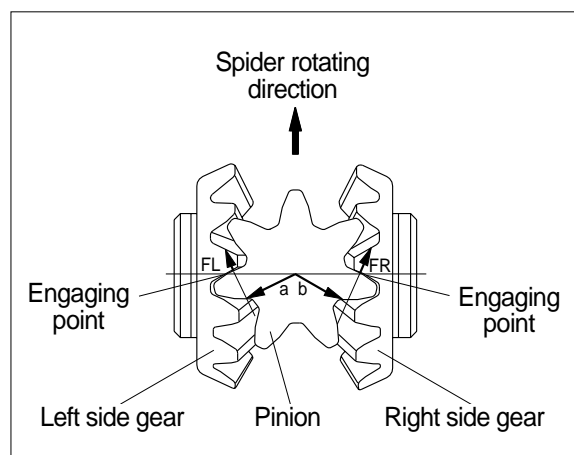

② **When traveling on soft ground**

(Resistance from road surface to left and right tires is different)

If the road resistance to the left wheel is smaller, the left side gear tends to rotate forward, and this rotation changes the engaging points between the side gears and pinion. As a result, the distances involving the engaging points becomes  $a > b$ . The pinion now is balanced as  $FL \times a = FR \times b$ , where  $FL > FR$ . The right side gear is driven with a greater force than the left side gear. The torque can be increased by up to about 30% for either side gear.

The pinion therefore does not run idle and driving power is transmitted to both side gears until the difference between road resistance to the right and left wheels reaches about 30%.

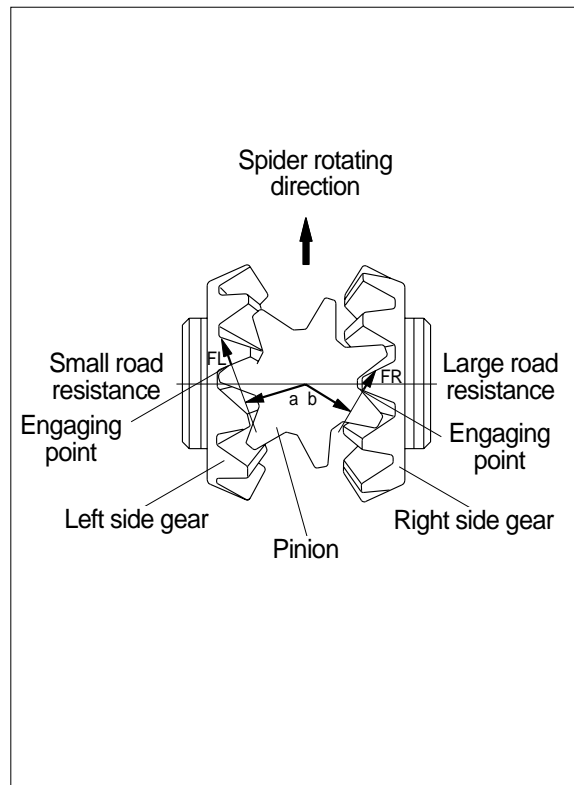

## 6) FINAL DRIVE(Front & rear)

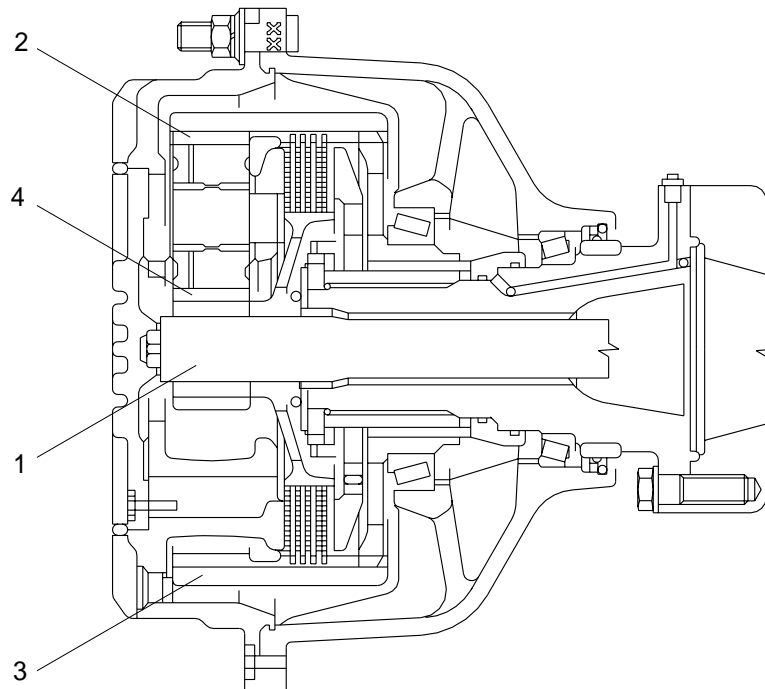

1 Axle shaft

2 Planetary gear

3 Ring gear

4 Sun gear

- (1) To gain a large drive force, the final drive uses a planetary gear system to reduce the speed and send drive force to the tires.
- (2) The power transmitted from the differential through axle shaft(1) to sun gear(4) is transmitted to planetary gear(2). The planetary gear rotates around the inside of a fixed ring gear(3) and in this way transmits rotation at a reduced speed to the planetary carrier. This power is then sent to the wheels which are installed to the planetary carriers.

## 5. TIRE AND WHEEL

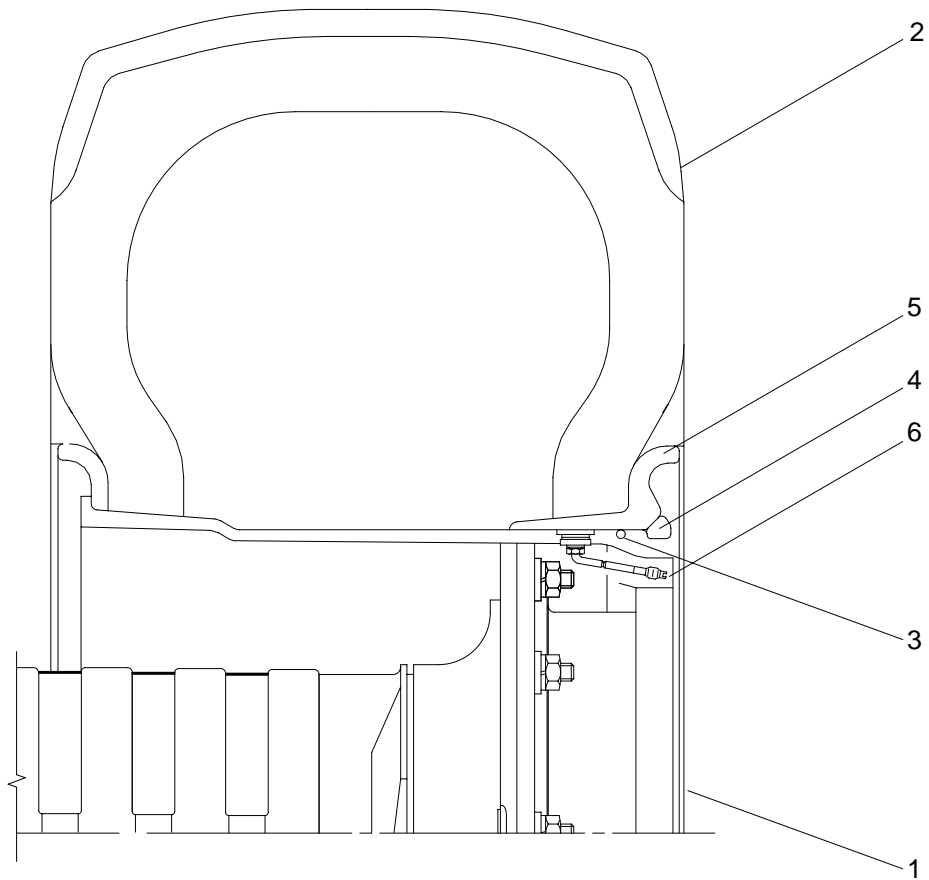

1 Wheel rim

2 Tire

3 O-ring

4 Lock ring

5 Side ring

6 Valve assembly

- 1) The tire acts to absorb the shock from the ground surface to the machine, and at the same time they must rotate in contact with the ground to gain the power which drives the machine.
- 2) Various types of tires are available to suit the purpose. Therefore it is very important to select the correct tires for the type of work and bucket capacity.