

# SECTION 7 ELECTRICAL SYSTEM

## GROUP 1 COMPONENT LOCATION

### 1. LOCATION 1

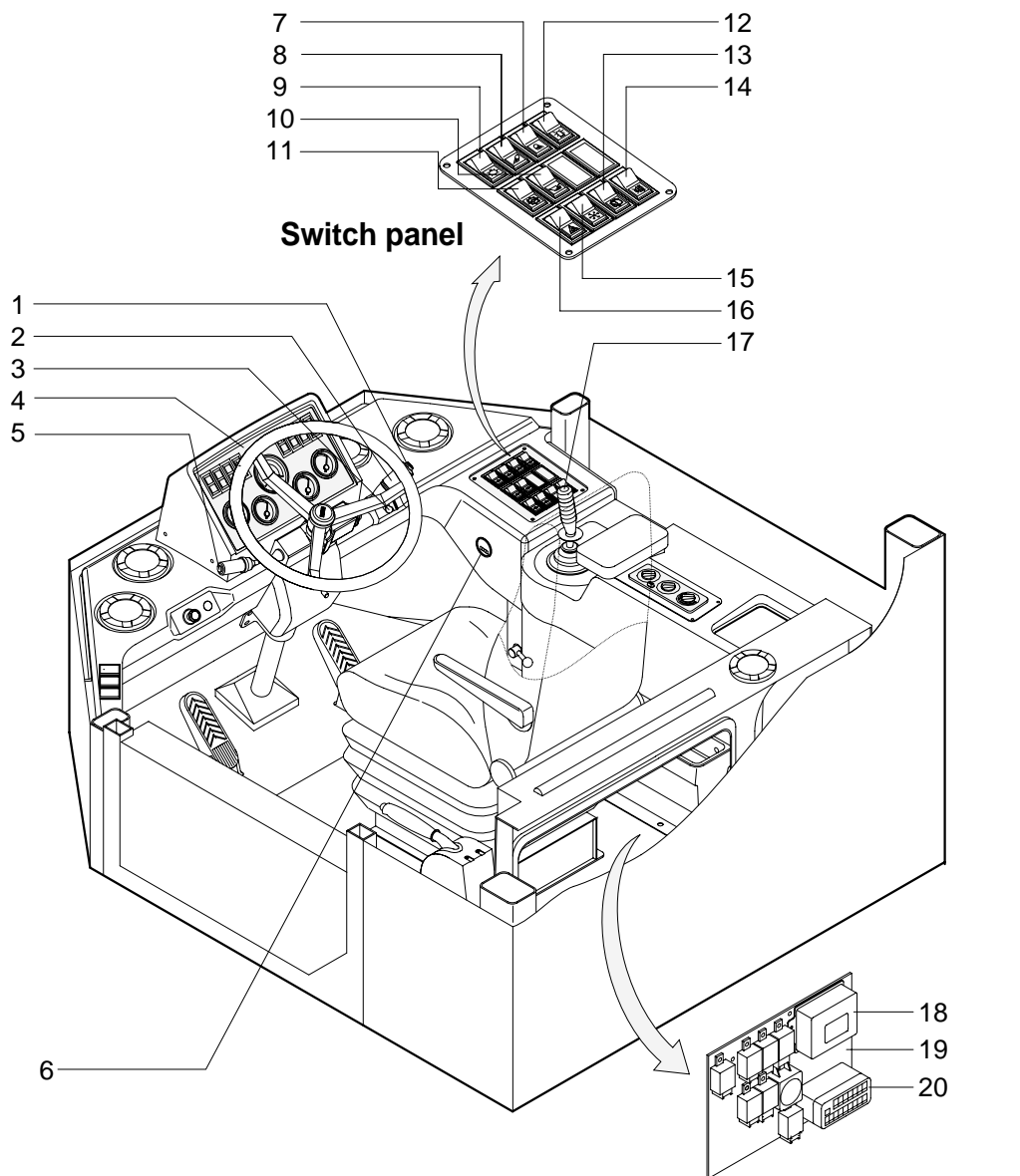

- |   |                       |    |                               |    |                  |
|---|-----------------------|----|-------------------------------|----|------------------|
| 1 | Horn button           | 8  | Front work lamp switch        | 15 | Aircon switch    |
| 2 | Multi function switch | 9  | Main light switch             | 16 | Hazard switch    |
| 3 | Starting switch       | 10 | Ride control switch(Optional) | 17 | Kick down switch |
| 4 | Cluster               | 11 | Clutch cut off switch         | 18 | Check unit       |
| 5 | Kick down switch      | 12 | Beacon switch(Optional)       | 19 | Relay board      |
| 6 | Service meter         | 13 | Rear wiper/washer switch      | 20 | Fuse box         |
| 7 | Rear work lamp switch | 14 | Buzzer stop switch            |    |                  |

## 2. LOCATION 2

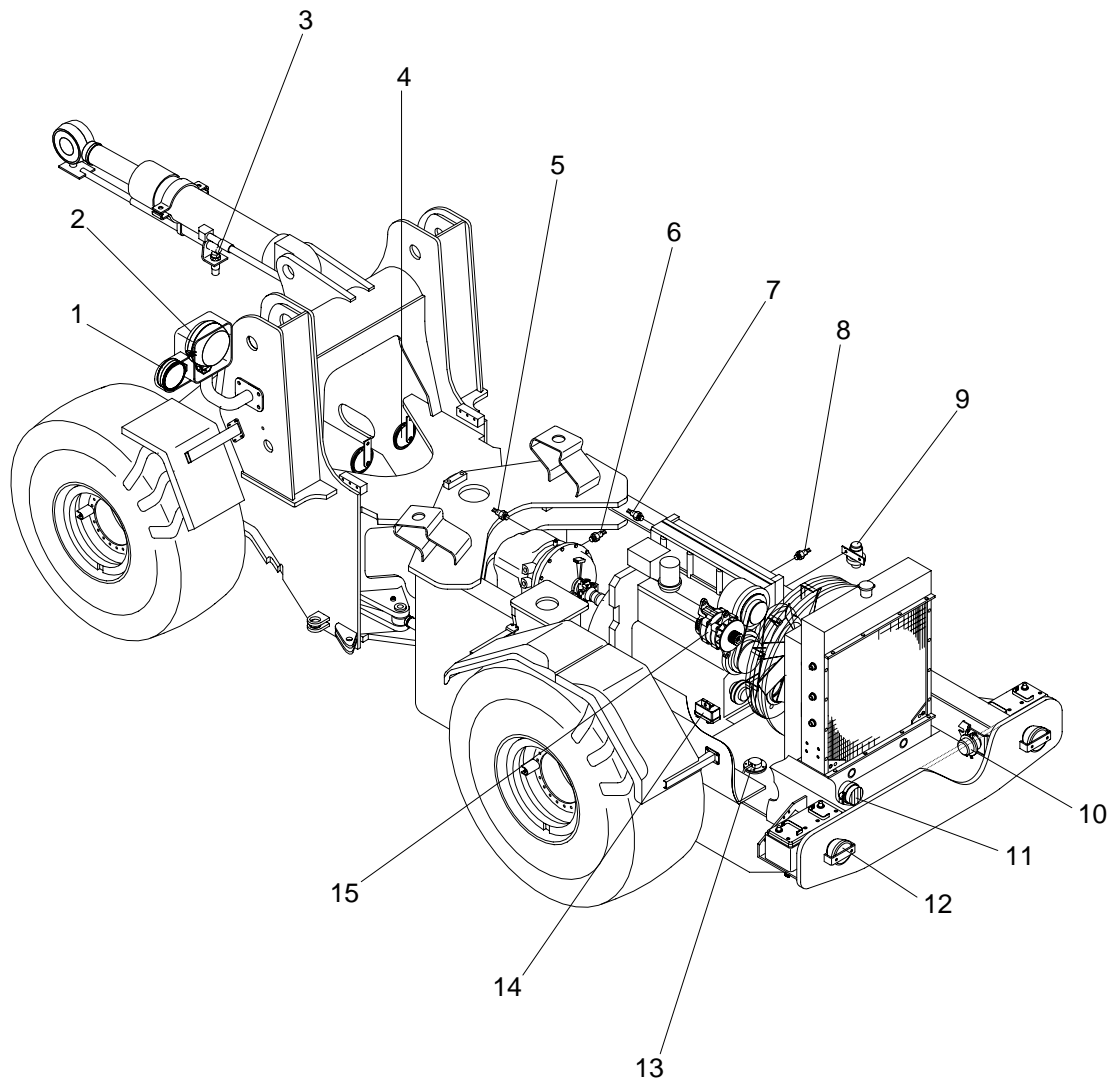

- |   |                        |    |                            |    |                       |
|---|------------------------|----|----------------------------|----|-----------------------|
| 1 | Turn lamp              | 6  | T/M oil pressure switch    | 11 | Backup buzzer         |
| 2 | Head lamp              | 7  | E/G oil temperature sender | 12 | Rear combination lamp |
| 3 | Proximate switch       | 8  | Water temperature switch   | 13 | Fuel sender           |
| 4 | Horn                   | 9  | Start relay                | 14 | Glow timer            |
| 5 | T/M temperature sender | 10 | Battery relay              | 15 | Alternator            |