

SERVICE MANUAL

HL660V

HL665V

TABLE OF CONTENTS

Safety

Wheel Loader Safety	SPC000029
---------------------------	-----------

Specifications

Specifications for	SPC000030
--------------------------	-----------

General Maintenance

General Maintenance Procedures.....	SPC000031
-------------------------------------	-----------

Standard Torques.....	SPC000032
-----------------------	-----------

Upper Structure

Counterweight.....	SPC000033
--------------------	-----------

Hydraulic Oil Tank	SPC000034
--------------------------	-----------

Lower Structure and Chassis

Center Joint (Articulation Joint).....	SPC000035
--	-----------

Engine and Drive Train

Engine.....	SPC000036
-------------	-----------

Front Axle	SPC000037
------------------	-----------

Rear Axle	SPC000038
-----------------	-----------

Air Conditioner.....	SPC000039
----------------------	-----------

Transmission and Torque Converter	SPC000040
---	-----------

Hydraulics

Cylinders.....	SPC000041
----------------	-----------

Main Pump.....	SPC000042
----------------	-----------

Steer Pump.....	SPC000043
-----------------	-----------

Main Control Valve.....	SPC000044
-------------------------	-----------

Pilot Control Valve	SPC000045
---------------------------	-----------

Priority Valve	SPC000046
----------------------	-----------

Steering Unit.....	SPC000047
--------------------	-----------

Hydraulic Schematic	SPC000048
---------------------------	-----------

Brake

Brake System SPC000049
Parking System..... SPC000050

Electrical System

Electrical SystemSPC000051
Electrical SchematicSPC000052

Attachments

SAFETY

WHEEL LOADER SAFETY

 **CAUTION!**

Follow all safety recommendations and safe shop practices outlined in the front of this manual or those contained within this section.

Always use tools and equipment that is in good working order.

Use lifting and hoisting equipment capable of safely handling load.

Remember, that ultimately safety is your own personal responsibility.

TABLE OF CONTENTS

To the Operator of a DISD Wheel Loader	3
General Safety Essentials	6
Location of Safety Labels	6
Unauthorized Modifications.....	6
General Hazard Information	7
Before Starting Engine	14
Machine Operation	17
Maintenance.....	24
Battery.....	32
Towing	34
Shipping and Transportation	35

TO THE OPERATOR OF A DISD WHEEL LOADER

DANGER!

Unsafe use of the wheel loader could lead to serious injury or death. Operating procedures, maintenance and equipment practices or traveling or shipping methods that do not follow the safety guidelines on the following pages could cause serious, potentially fatal injuries or extensive damage to the machine or nearby property.

Please respect the importance of taking responsibility for your own safety, and that other people who may be affected by your actions.

Safety information on the following pages is organized into the following topics.

1. "General Safety Essentials" on page 6.
2. "Location of Safety Labels" on page 6.
3. "Unauthorized Modifications" on page 6.
4. "General Hazard Information" on page 7.
5. "Before Starting Engine" on page 15.
6. "Machine Operation" on page 18.
7. "Maintenance" on page 25.
8. "Battery" on page 33.
9. "Towing" on page 35.
10. "Shipping and Transportation" on page 36.

WARNING!

Improper operation and maintenance of this machine can be hazardous and could result in serious injury or death.

Operator and maintenance personnel should read this manual thoroughly before beginning operation or maintenance.

Keep this manual in the storage compartment to the rear of the operator's seat, and have all personnel involved in working on the machine periodically read the manual.

Some actions involved in operation and maintenance of the machine can cause a serious accident, if they are not done in a manner described in this manual.

The procedures and precautions given in this manual apply only to intended uses of the machine.

If you use your machine for any unintended uses that are not specifically prohibited, you must be sure that it is safe for any others. In no event should you or others engage in prohibited uses or actions as described in this manual.

SAFETY ALERT SYMBOL

Be Prepared - Get to Know All Operating and Safety Instructions

This is the Safety Alert Symbol. Wherever it appears - in this manual or on safety signs on the machine - you should be alert to potential for personal injury or accidents. Always observe safety precautions and follow recommended procedures.

LEARN SIGNAL WORDS USED WITH SAFETY ALERT SYMBOL

Words "**CAUTION**" "**WARNING**" and "**DANGER**" used throughout this manual and labels on machine indicate hazards or unsafe practices. All three statements indicate that safety is involved. Observe precautions indicated whenever you see the Safety Alert "Triangle," no matter which signal word appears next to the "Exclamation Point" symbol.

CAUTION!

This word is used on safety messages and safety labels and indicates potential of a hazardous situation that, if not avoided, could result in minor or moderate injury. It may also be used to alert against a generally unsafe practice.

WARNING!

This word is used on safety messages and safety labels and indicates potential of a hazardous situation that, if not avoided, could result in serious injury or death. It may also be used to alert against a highly unsafe practice.

DANGER!

This word is used on safety messages and safety labels and indicates imminent hazard of a situation that, if not avoided, is very likely to cause death or extremely serious injury. It may also be used to alert against equipment that may explode or detonate if handled or treated carelessly.

Safety precautions are described in SAFETY from page 6 on.

DISD cannot predict every circumstance that might involve a potential hazard in operation and maintenance. Therefore the safety messages in this manual and on the machine may not include all possible safety precautions. If any procedures or actions not specifically recommended or allowed in this manual are used, you must be sure that you and others can do such procedures and actions safely and without damaging the machine.

GENERAL SAFETY ESSENTIALS

LOCATION OF SAFETY LABELS

Location of safety labels (decals) can vary from unit to unit. Refer to appropriate Operation and Maintenance Manual, and Parts Manual for your unit.

There are several specific warning signs on this machine. The exact location of hazards and the description of the hazards are reviewed in the appropriate Operation and Maintenance Manual.

Please become familiarized with all warning signs.

Make sure that all of the warning signs are legible. Clean the warning signs or replace the warning signs if you cannot read the words. Replace the illustrations if the illustrations are not visible. When you clean the warning signs, use a cloth, water and soap. Do not use solvent, gasoline, or other harsh chemicals to clean the safety signs. Solvents, gasoline, or other harsh chemicals could loosen the adhesive that secures the warning sign. Loose adhesive will allow the warning sign to fall off.

Replace any safety sign that is damaged, or missing. If a safety sign is attached to a part that is replaced, install a safety sign on the replacement part.

UNAUTHORIZED MODIFICATIONS

Any modification made without authorization or written approval from DISD can create a safety hazard, for which the machine owner must be held responsible.

For safety's sake, replace all OEM parts with the correct authorized or genuine DISD part. For example, not taking the time to replace fasteners, bolts or nuts with the correct replacement parts could lead to a condition in which the safety of critical assemblies is dangerously compromised.

GENERAL HAZARD INFORMATION

SAFETY RULES

Only trained and authorized personnel can operate and maintain the machine.

Follow all safety rules, precautions and instructions when operating or performing maintenance on the machine.

Do not operate the machine if you are not feeling well, if you are taking medication that makes you feel sleepy, if you have been drinking, or if you are suffering from emotional problems. These problems will interfere with your sense of judgment in emergencies and may cause accidents.

When working with another operator or with a person on work site traffic duty, be sure that all personnel know the nature of the work and understand all hand signals that are to be used.

Always observe strictly any other rules related to safety.

SAFETY FEATURES

Be sure that all guards and covers are installed in their proper position. Have guards and covers repaired immediately if damaged.

Be sure that you understand the method of use of safety features such as transmission lever neutral lock and the seat belt, and use them properly.

Never remove any safety features. Always keep them in good operating condition.

Failure to use safety features according to the instructions in the Operation and Maintenance Manual could result in serious bodily injury.

INSIDE OPERATOR'S COMPARTMENT

When entering the operator's compartment, always remove all mud and oil from the soles of your shoes. If you operate the accelerator and brake pedals with mud or oil stuck to your shoes, your foot may slip and this may cause a serious accident.

Clean grease and dirt from pedals and controls. This contributes to safe operation. Cleaning also provides an opportunity to inspect equipment. Minor damage can be repaired or corrected before major problems result.

Keep cab floor and consoles free of tools and personal items.

After using the ashtray, make sure that any matches or cigarettes are properly extinguished, and be sure to close the ashtray. If the ashtray is left open, there is danger of fire.

Do not stick suction pads to the window glass. Suction pads act as a lens and may cause fire.

Do not leave lighters lighting around the operator's compartment. If the temperature inside the operator's compartment becomes high, there is danger that the lighter may explode.

Do not use cellular telephones inside the operator's compartment when driving or operating the machine.

There is danger that this may lead to an unexpected accident.

Never bring any dangerous objects such as flammable or explosive items into the operator's cab. To ensure safety, do not use the radio or music headphones when operating the machine. There is danger that this may lead to a serious accident.

When operating the machine, do not put your hands or head out of the window.

When standing up from the operator's seat, always place transmission neutral lock lever in the "LOCK" position and set pilot cutoff switch to "O" (OFF) position. If you accidentally touch the work equipment levers when they are not locked, the machine may suddenly move and cause serious injury or damage.

When leaving the machine, lower the work equipment completely to the ground, set transmission neutral lock lever in the "LOCK" position, set pilot cutoff switch to "O" (OFF) position, "APPLY" parking brake, and shut down engine. Use the key to lock all the equipment. Always remove the key and take it with you.

CLOTHING AND PERSONAL PROTECTIVE ITEMS

Contain long hair, and avoid loose clothing and jewelry. They can catch on controls or in protruding parts and cause serious injury or death.

Do not wear oily clothes. They are highly flammable.

Full eye protection, a hard hat, safety shoes and gloves may be required at the work site. While working on the machine, never use inadequate tools.

They could break or slip, causing injury, or they may not adequately perform intended functions.

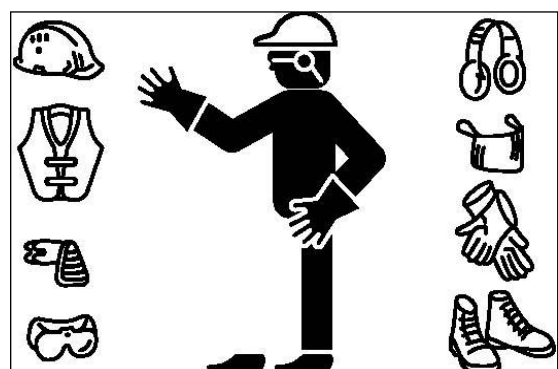

Figure 1

BREATHING MASKS, EAR PROTECTION MAY BE REQUIRED

Do not forget that some risks to your health may not be immediately apparent. Exhaust gases and noise pollution may not be visible, but these hazards can cause disabling or permanent injuries.

ASBESTOS DUST HAZARD PREVENTION

Asbestos dust can be hazardous to your health if it is inhaled. Materials containing asbestos fiber can be present on work site. Breathing air that contains asbestos fiber can ultimately cause serious or fatal lung damage. To prevent lung damage from asbestos fiber, observe following precautions;

- Use a respirator that is approved for use in an asbestos-laden atmosphere.
- Never use compressed air for cleaning.
- Use water for cleaning to keep down the dust.
- Work on the machine or component with the wind at your back whenever possible.
- Always observe any rules and regulations related to the work site and working environment

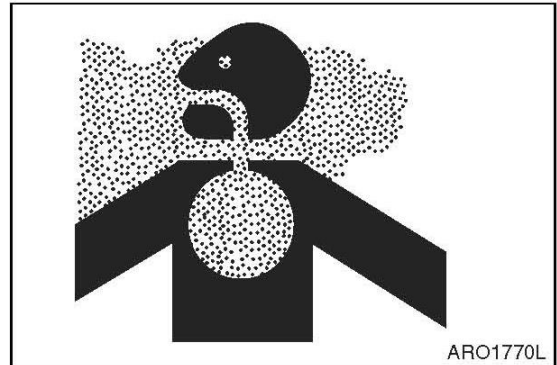

Figure 2

MOUNTING AND DISMOUNTING

Before getting on or off the machine, if there is any oil, grease, or mud on the handrails, steps, or track shoes, wipe it off immediately. Always keep these parts clean. Repair any damage and tighten any loose bolts.

Never get on or off a moving machine. In particular, never get on or off a moving machine. These actions may lead to serious injury.

When getting on or off the machine, always face the machine, and maintain a three-point contact (both feet and one hand or one foot and both hands) with the handholds and steps to ensure that you support yourself securely.

Never hold any control levers when getting on or off the machine.

Never get up from operator's seat or leave operator's station and dismount machine if engine is running.

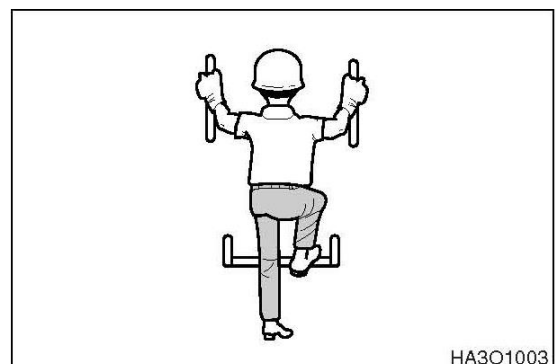

Figure 3

FUEL, OIL AND HYDRAULIC FLUID FIRE HAZARDS

Fuel, oil and antifreeze will catch fire if it is brought close to a flame. Fuel is particularly flammable and can be hazardous.

Always strictly observe the following.

Add fuel, oil, antifreeze and hydraulic fluid to the machine only in a well-ventilated area. The machine must be parked with controls, lights and switches turned "OFF." The engine must be "OFF" and any flames, glowing embers, auxiliary heating units or spark-causing equipment must be doused, turned off and/or kept well clear of the machine.

Static electricity can produce dangerous sparks at the fuel filling nozzle. In very cold, dry weather or other conditions that could produce a static discharge, keep the tip of the fuel nozzle in constant contact with the neck of the fuel filling nozzle, to provide a ground.

Keep fuel and other fluid reservoir caps tight and do not start the engine until caps have been secured.



Figure 4

PRECAUTIONS WHEN HANDLING FLUIDS AT HIGH TEMPERATURE

Immediately after operations are stopped, the coolant, engine oil, and hydraulic oil are at high temperature and the radiator and hydraulic tank are still under pressure. Attempting to remove the cap, drain the oil or coolant, or replace the filters may lead to serious burns. Always wait for the temperature to go down, and follow the specified procedures when carrying out these operations.

To prevent hot coolant from spurting out, shut down engine, wait for the coolant to cool, then loosen the cap slowly to relieve the pressure. To prevent hot oil from spurting out, shut down engine, wait for the oil to cool, then loosen the cap slowly to relieve the pressure.

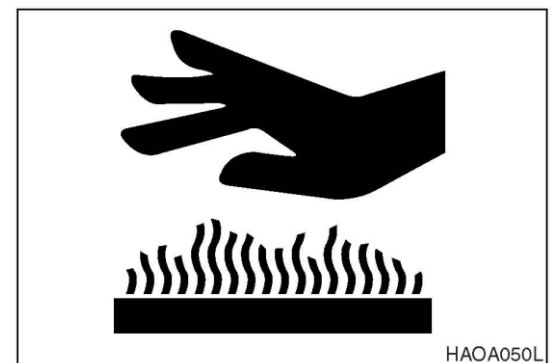

Figure 5



Figure 6

INJURY FROM WORK EQUIPMENT

Do not enter or put your hand, arm or any other part of your body between movable parts, such as between the work equipment and cylinders, or between the machine and work equipment.

If the control levers are operated, the clearance between the machine and the work equipment will change and this may lead to serious damage or personal injury.

If going between movable parts is necessary, always position and secure the work equipment so that it cannot move.

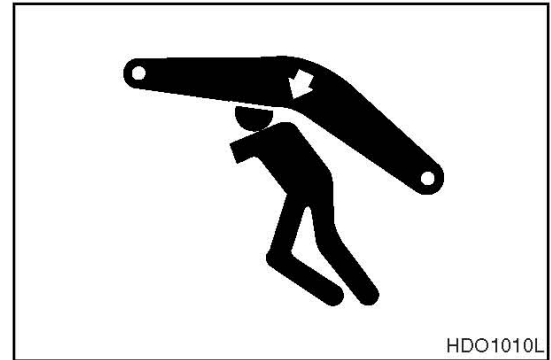

Figure 7

FIRE EXTINGUISHER AND FIRST AID KIT

As a precaution if any injury or fire should occur, always do the following.

- Be sure that fire extinguishers have been provided and read the labels to ensure that you know how to use them. It is recommended that an appropriately sized (2.27 kg [5 lb] or larger) multipurpose "A/B/C" fire extinguisher be mounted in the cab. Check and service the fire extinguisher at regular intervals and make sure that all work site crew members are adequately trained in its use.
- Provide a first aid kit in the storage compartment and keep another at the work site. Check the kit periodically and make any additions if necessary.
- Know what to do in case of injury from fire.
- Keep emergency numbers for doctor, ambulance service, hospital and fire department your telephone.

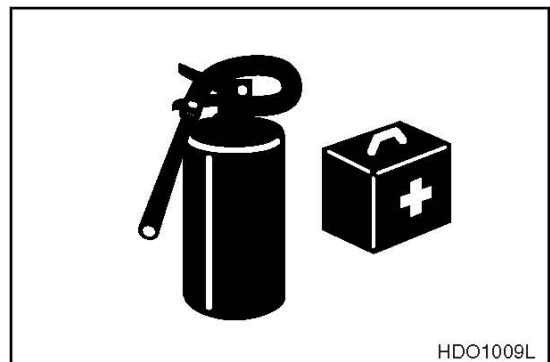

Figure 8

If the machine catches fire, it may lead to serious personal injury or death. If a fire occurs during operation, escape from the machine as follows;

- Turn the starter switch "OFF" and shut down engine.
- If there is time, use the fire extinguisher to extinguish as much of the fire as possible.
- Use the handrails and steps to escape from the machine.

The above is the basic method for escaping from the machine, but changing the method may be necessary according to the conditions, so carry out practice drills at the work site.

PROTECTION FROM FALLING OR FLYING OBJECTS

On work sites where there is danger that falling objects or flying objects may hit the operator's cab select a guard to match the operating conditions to protect the operator.

Work in mines, tunnels, deep pits or on loose or wet surfaces could produce danger of falling rock, roll over or hazardous flying objects. Additional protection for operator's cab could be required in form of a FOPS/Falling Object Protective Structure and/or ROPS/Roll over Protective Structure reinforcement system (Option).

Any reinforcement system that is installed on machine must pass safety and certification standards and carry appropriate labeling and rating information. For example, most often added type of reinforcement system, FOPS, must meet or exceed Society of Automotive Engineers standard SAE J1356, "Performance Criteria for Falling Object Guards for Wheel loaders. (Option)"

Never attempt to alter or modify any type of protective structure reinforcement system, by drilling holes, welding or remounting or relocating fasteners. Any serious impact or damage to system requires a complete integrity reevaluation. Reinstallation, recertification and/ or replacement of system may be necessary.



Figure 9



Figure 10

INSTALL ADDITIONAL SAFETY EQUIPMENT IF CONDITIONS REQUIRE

Laminate glass protection for the front, side or rear windows may also be recommended depending upon particular site conditions.

Contact your distributor for available safety guards and/or recommendations if there is any danger of getting hit by objects that could strike the operator's cab. Make sure that all other work site crew members are kept well away from wheel loader and safe from potential hazards.

MAINTAIN STANDARD SAFETY EQUIPMENT IN GOOD CONDITION

Machinery guards and body panel covers must be in place at all times. Keep well clear of rotating parts. Pinch point hazards such as cooling fan and alternator drive belts could catch hair, jewelry or oversize or very loose clothing.

Safety labels must be replaced if they are damaged or become unreadable. Information on labels gives work crew members an important safety reminder. Part numbers for each decal and required mounting locations are shown on pages 1-2 through 1-4 of this section.

ATTACHMENT PRECAUTIONS

Options kits are available through your dealer. Contact for information on available one-way (single-acting) and two-way (double-acting) piping / valving / auxiliary control kits. Because cannot anticipate, identify or test all attachments that owners may wish to install on their machines, please contact for authorization and approval of attachments and their compatibility with options kits.

ACCUMULATOR

The pilot control system is equipped with an accumulator. For a brief period of time after the engine has been shut down, the accumulator will store a pressure charge that may enable hydraulic controls to be activated. Activation of any controls may enable the selected function to operate under force of gravity. When performing maintenance on the pilot control system, the hydraulic pressure in the system must be released as describe in Operation and Maintenance Manual.

The accumulator is charged with high-pressure nitrogen gas, so it is extremely dangerous if it is handled in the wrong way. Always observe the following precautions;

- Do not drill or make any holes in the accumulator or expose it any flame, fire or heat source.
- Do not weld on the accumulator, or try attaching anything to it.
- When carrying out disassembly or maintenance of the accumulator, or when disposing of the accumulator, the charged gas must be properly released. Contact your distributor.
- Wear safety goggles and protective gloves when working on an accumulator. Hydraulic oil under pressure can penetrate the skin and cause serious injuries.

ENGINE VENTILATION

Engine exhaust gases can cause loss of judgment, loss of alertness, and loss of motor control. These gases can also cause unconsciousness, serious injury and fatal accidents.

Make sure of adequate ventilation before starting engine in any enclosed area.

You should also be aware of open windows, doors or ductwork into which exhaust may be carried, or blown

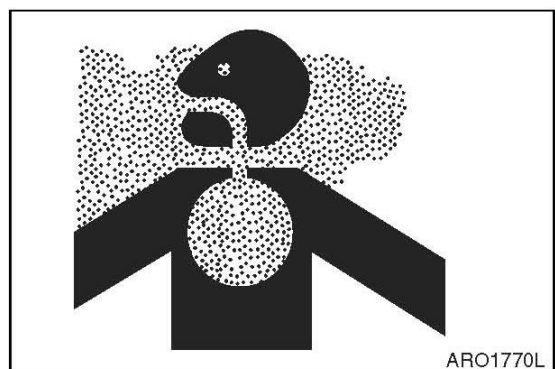

Figure 11

BEFORE STARTING ENGINE

WORK SITE PRECAUTIONS

Before starting operations, thoroughly check the area for any unusual conditions that could be dangerous.

Check the terrain and condition of the ground at the work site, and determine the best and safest method of operation.

Make the ground surface as hard and horizontal as possible before carrying out operations. If there is a lot of dust and sand on the work site, spray water before starting operations.

If you need to operate on a street, protect pedestrians and cars by designating a person for work site traffic duty or by erecting fences and posting "No Entry" signs around the work site.

Erect fences, post "No Entry" signs, and take other steps to prevent people from coming close to or entering the work site. If people come close to a moving machine, they may be hit or caught by the machine, and this may lead to serious personal injury or death.

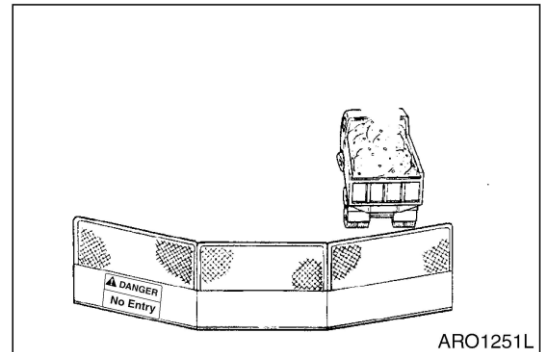

Figure 12

Water lines, gas lines, phone lines and high-voltage electrical lines may be buried under the work site. Contact each utility and identify their locations. Be careful not to damage or cut any of these lines.

NEVER be in water that is in excess of the permissible water depth. Refer to "Operation Manual."

Any type of object in the vicinity of the boom could represent a potential hazard, or cause the operator to react suddenly and cause an accident. Use a spotter or signal person working near bridges, phone lines, work site scaffolds, or other obstructions.

Minimum levels of insurance coverage, work permits or certification, physical barriers around the work site or restricted hours of operation may be mandated by governing authorities. There may also be regulations, guidelines, standards or restrictions on equipment that may have to be followed for local requirements.

There may also be regulations related to performing certain kinds of work. If there is any question about whether your machine and work site complies with the applicable standards and regulations contact your local authorities and agencies.

Avoid entering soft ground. It will be difficult for the machine to escape.

Avoid operating your machine too close to the edge of cliffs, overhangs, and deep ditches. The ground may be weak in such areas. If the ground should collapse, the machine could fall or tip over and this could result in serious injury or death.

Remember that the soil after heavy rain, blasting or after earthquakes, is weakened in these areas.

Earth laid on the ground and the soil near ditches is loose. It can collapse under the weight of vibration of your machine and cause your machine to tip over. Install the head guard (FOPS) if working in areas where there is danger of falling rocks.

CHECKS BEFORE STARTING ENGINE

Every day before starting the engine for the first time, carry out the following checks. If these checks are not carried out properly, there is danger of serious injury.

- Completely remove all wood chips, leaves, grass, paper and other flammable materials accumulated in the engine compartment and around the battery. They could cause a fire.
Remove any dirt from the window glass, mirrors, handrails, and steps.
- Do not leave tools or spare parts laying around in the operator's compartment. The vibration of the machine when traveling or during operations may cause them to fall and damage or break the control levers or switches. They may also get caught in the gap of the control levers and cause the work equipment to malfunction or move dangerously. This may lead to unexpected accidents.
- Check the coolant level, fuel level, and hydraulic tank oil level, and check for clogged air cleaner and damage to the electrical wiring.
- Adjust the operator's seat to a position where it is easy to operate the machine, and check the seat belt and mounts for damage and wear.
- Check the operation of the gauges and the angle of the mirrors, and check that the safety lever is in "LOCKED" position.
- If any abnormalities are found in the above checks, carry out repairs immediately.

ENGINE STARTING

- Walk around your machine before getting in operator's cab. Look for evidence of leaking fluid, loose fasteners, misaligned assemblies or any other indications of possible equipment hazard.
- All equipment covers and machinery safety guards must be in place, to protect against injury while machine is being operated.
- Look around work site area for potential hazards, or people or property that could be at risk while operation is in progress.
- NEVER start engine if there is any indication that maintenance or service work is in progress, or if a warning tag is attached to controls in cab.
- A machine that has not been used recently, or is being operated in extremely cold temperatures, could require a warm-up or maintenance service before start up.
- Check gauges and monitor displays for normal operation before starting engine. Listen for unusual noises and remain alert for other potentially hazardous conditions at start of work cycle.
- Check tire inflation and check tires for damage or uneven wear. Perform maintenance before operation.
- Do not short circuit the starting motor to start the engine. This is not only dangerous, but may also damage the machine.
- When starting the engine, sound the horn as an alert.
- Start and operate the machine only while seated.

BEFORE OPERATING MACHINE

If checks are not carried out properly after starting the engine, it may result in a delay in discovering abnormalities in the machine, and this may lead to personal injury or damage to the machine.

Carry out the checks in an open area where there are no obstructions. Do not let anyone near the machine when carrying out the checks.

- Check the operating condition of the equipment, and the actuation of the bucket, boom, and travel systems.
- Check the machine for any abnormal noise, vibration, heat, smell, or abnormality with the gauges. Check also for leakage of air, oil, and fuel.
- If any abnormality is found, repair the problem immediately. If the machine is used without repairing the problems, it may lead to unexpected injury or failure.
- Clear all personnel from directly around machine and from the area.
- Clear all obstacles from the machine's path. Beware of hazards.
- Be sure that all windows are clean. Secure the doors and the windows in the open position or in the shut position.
- Adjust the rear view mirrors for best visibility close to the machine. Make sure that the horn, the travel alarm (if equipped), and all other warning devices are working properly.
- Fasten the seat belt securely.
- Warm up the engine and hydraulic oil before operating machine.
- Before moving the machine, check the position of undercarriage. The normal travel position is with idler wheels to the front under the cab and the drive sprockets to the rear. When the undercarriage is in the reversed position, the travel controls must be operated in opposite directions

MACHINE OPERATION

IMPORTANT

If you need more information or have any questions or concerns about safe operating procedures or working the wheel loader correctly in a particular application or in the specific conditions of your individual operating environment, please consult your local representative.

OPERATE WHILE SEATED AT OPERATOR'S STATION ONLY

Never reach in through a window to work a control. Do not try to operate wheel loader unless you're in command position - seated at controls. You should stay alert and focused on your work at all times. Do not twist out of seat if job activity behind you (or to the side) requires your attention.

Use a spotter or signal person if you cannot see clearly and something is happening behind you.

Replace damaged safety labels and lost or damaged operator's manuals.

Do not let anyone operate machine unless they've been fully and completely trained, in safety and in operation of the machine.

SEAT BELTS SHOULD BE USED AT ALL TIMES

Whenever engine is running, operator should be seated at the control station with seat belt properly engaged.

MOVEMENT ALARMS

If wheel loader is equipped with an audible travel movement alarm, test alarm on a daily basis. Audible alarm should sound as soon as travel system is engaged.



Figure 13



Figure 14

TRAVEL PRECAUTIONS

When traveling, wheel loader always keeps lights on; make sure that you are in compliance with all state and local regulations concerning warning flags and signs.

Never turn the starter switch to the "O" (OFF) position when traveling. It is dangerous if the engine stops when the machine is traveling. It will be impossible to operate the steering unless the unit is equipped with an emergency steering system.

Pilot control valve lever (joystick) should not be operated while traveling.

Lower work equipment so that it is 300 mm (12 in) above ground.

Never travel over obstacles or slopes that will cause machine to tilt severely. Travel around any slope or obstacle that causes 10° tilt, or more.

Do not operate the steering suddenly. The work equipment may hit the ground and cause the machine to lose its balance, and this may damage the machine or structures in the area.

When traveling on rough ground, travel at low speed, and avoid sudden changes in direction.

Always keep to the permissible water depth.

When traveling over bridges or structures on private land, check first that the bridge or structure can withstand the weight of the machine. When traveling on public roads, check with the local authorities and follow their instructions.

SLOPING TERRAIN REQUIRES CAUTION

Dig evenly around work site whenever possible, trying to gradually level any existing slope. If it's not possible to level area or avoid working on a slope, reducing size and cycling rate workload is recommended.

On sloping surfaces, use caution when positioning wheel loader before starting a work cycle. Stay alert for unstable situations to avoid getting into them. For example, you should always avoid working bucket over downhill side of machine when parked perpendicular to slope. Avoid full extensions of bucket in a downhill direction. Lifting bucket too high, too close to machine, while wheel loader is turned uphill can also be hazardous.

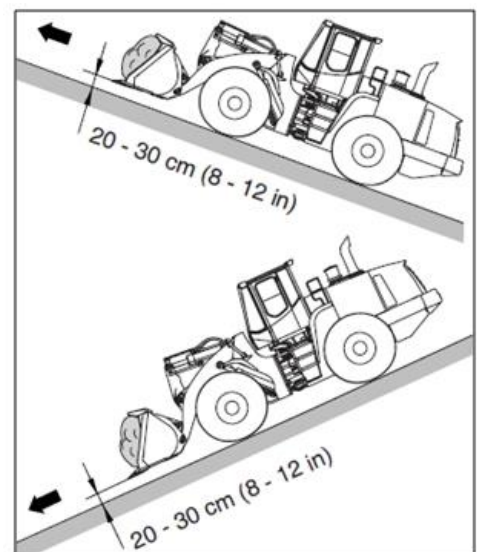

Figure 15

AVOID HIGH-VOLTAGE CABLES

Serious injury or death can result from contact or proximity to high-voltage electric lines. The bucket does not have to make physical contact with power lines for current to be transmitted.

Use a spotter and hand signals to stay away from power lines not clearly visible to operator.

VOLTAGE	MINIMUM SAFE DISTANCE
6.6 kV	3 m (9' 10")
33.0 kV	4 m (13' 1")
66.0 kV	5 m (16' 5")
154.0 kV	8 m (26' 3")
275.0 kV	10 m (32' 10")

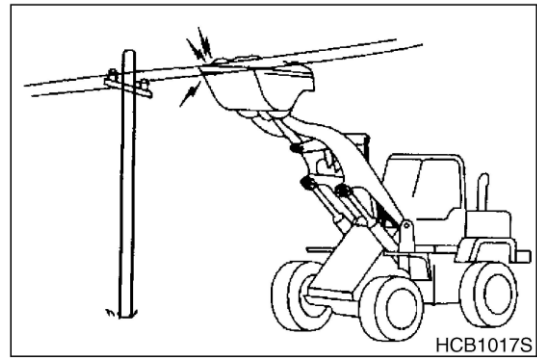

Figure 16

Use these minimum distances as a guideline only. Depending upon voltage in line and atmospheric conditions, strong current shocks can occur with boom or bucket as far away as 4 - 6 m (13 - 20 ft) from power line. Very high voltage and rainy weather could further decrease that safety margin.

NOTE: Before starting any type of operation near power lines (either above ground or buried cable-type) you should always contact power utility directly and work out a safety plan with them.

BEFORE STARTING TO DIG, CONTACT AUTHORITIES

Below ground hazards also include natural gas lines, water mains, tunnels and buried foundations. Know what's underneath work site before starting to dig.

BE AWARE OF HEIGHT OBSTACLES

Any type of object in vicinity of boom could represent a potential hazard, or cause operator to react suddenly and cause an accident. Use a spotter or signal person working near bridges, phone lines, work site scaffolds, or other obstructions.

USE CARE ON LOOSE SUPPORT

Working heavy loads over loose, soft ground or uneven, broken terrain can cause dangerous side load conditions and possible tip over and injury. Travel without a load or balanced load may also be hazardous. If temperatures are changing, be cautious of dark and wet patches when working or traveling over frozen ground. Stay away from ditches, overhangs and all other weak support surfaces. Halt work and install support mats or blocking if work is required in an area of poor support.

USE SOLID SUPPORT BLOCKING

Never rely on lift jacks or other inadequate supports when work is being done. Block wheels fore and aft to prevent any movement.

DIGGING BENEATH OVERHANGS

Digging beneath an overhang is dangerous. Overhand could collapse on top of operator and cause serious injury or death. Go on to another digging area before steep overhangs are formed. Know height and reach limits of wheel loader and plan ahead while working. Park wheel loader away from overhangs before work shut down.

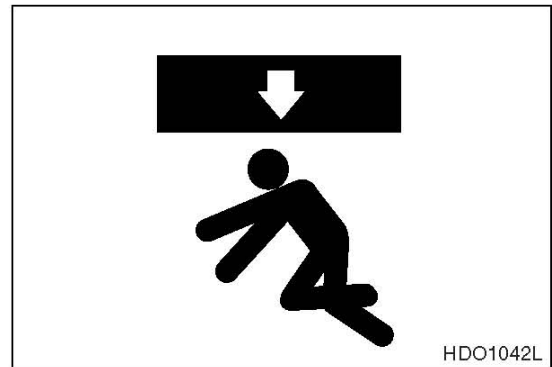

Figure 17

DIGGING BENEATH WHEEL LOADER

Digging beneath wheel loader is dangerous. Earth beneath could collapse. This could cause wheel loader to tip, which could cause serious injury or death to operator. Working around deep pits, trenching or along high walls may require support blocks, especially after heavy rainfalls or during spring thaws.

STAY ALERT FOR PEOPLE MOVING THROUGH WORK AREA

When loading a truck you should always know where the driver is.

Avoid loading over the cab of a truck even if the driver is in a safe spot. Someone else could have gone inside, for any number of reasons. Avoid working where unseen passersby might be.

Slow down work cycle and use slower travel speeds in congested or populated areas. Use a commonly understood signal so that other members of work crew can warn operator to slow or halt work in an impending hazardous situation.

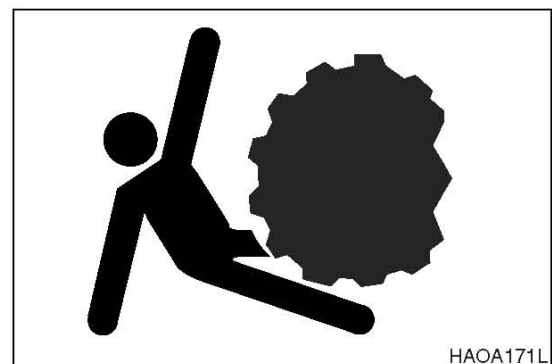

Figure 18

BE AWARE OF AND CONFORM TO LOCAL REGULATIONS

Minimum levels of insurance coverage, work permits or certification, physical barriers around work-site or restricted hours of operation may be mandated by governing authorities. There may also be guidelines, standards or restrictions on equipment that may be used to perform certain kinds of work. Check and follow all local requirements, which may also be related to below ground hazards and power lines.

NEVER USE ETHER STARTING AIDS

An electric-grid type manifold heater is used for cold starting. Glowing heater element can cause ether or other starting fluid to detonate, causing injury.

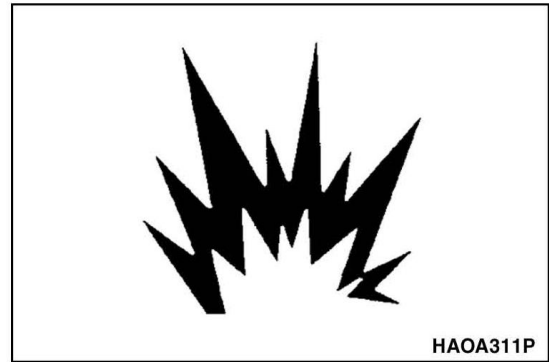

Figure 19

OBSERVE GENERAL SAFETY RULES

Only trained and authorized personnel, with a good knowledge and awareness of safe procedures, may be allowed to operate or perform maintenance or service on wheel loader.

All personnel at work site should be aware of assigned individual responsibilities and tasks.

Communication and hand signals used should be understood by everyone.

Terrain and soil conditions at work site, approaching traffic, weather-related hazards and any above or below ground obstacles or hazards should be observed and monitored by all work crew members.

TAKE TIME TO PROVIDE GOOD VISIBILITY

Be careful not to go close to the edge of a cliff by mistake.

Use the machine only for its main purpose. Using it for other purposes will cause failures.

To ensure an ample view, do as follows:

- When working in dark areas, attach working lights and front lights to the machine. If necessary, set up lighting at the work site.
- Stop operations when the visibility is poor, such as in fog, mist, snow, and rain. Wait for the visibility to improve to a level which causes no problems for the operation.
- Keep dirt and dust off of windows and off lens surfaces of work lights. Stop working if lights, windows or mirrors need cleaning or adjustment.

To avoid hitting the work equipment, always do the following;

- When working in tunnels, on bridges, under electric wires, or when parking the machine or carrying out other operations in places with limited height, be extremely careful not to hit the bucket or other parts.
- To prevent collisions, operate the machine at a safe speed when working in confined spaces, indoors, or in crowded areas.
- Do not pass the bucket over the heads of workers or over the operator's compartment of dump truck.

KEEP "PINCH POINT" AREAS CLEAR – USE CAUTION IN REVERSE

Use a signal person in high traffic areas and whenever operator's view is not clear, such as when traveling in reverse.

Anyone standing near wheels, or working assemblies of the attachment, is at risk of being caught between moving parts of machine.

Never allow anyone to ride on any part of machine or attachment, including any part of operator's cab.

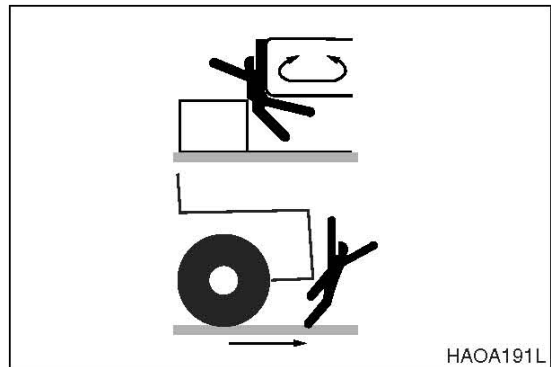

Figure 20

OPERATE CAREFULLY ON SNOW AND ICE AND IN VERY COLD TEMPERATURES

In icy cold weather avoid sudden travel movements and stay away from even very slight slopes. Machine could skid off to one side very easily.

Snow accumulation could hide or obscure potential hazards. Use care while operating or while using machine to clear snow.

Warming up engine for a short period may be necessary, to avoid operating with sluggish or reduced working capacity. Jolting shocks and impact loads caused by bumping or bottoming boom or attachment are more likely to cause severe stress in very cold temperatures. Reducing work cycle rate and work load may be necessary.

When the temperature rises, frozen road surfaces become soft, so the machine travel becomes unstable.

In cold weather, do not touch metal surfaces with your bare hands. If you touch a metal surface in extremely cold weather, your skin may freeze to the metal surface.

PARKING MACHINE

Avoid making sudden stops, or parking machine wherever it happens to be at the end of the work day. Plan ahead so that the wheel loader will be on firm, level ground away from traffic and away from high walls, cliff edges and any area of potential water accumulation or runoff. If parking on inclines is unavoidable, block wheels to prevent movement. Lower bucket or other working attachment completely to ground, or to an overnight support saddle. There should be no possibility of unintended or accidental movement.

When parking on public roads, provide fences, signs, flags, or lights, and put up any other necessary signs to ensure that passing traffic can see the machine clearly, and park the machine so that the machine, flags, and fences do not obstruct traffic.

SHUTDOWN CONTROL FUNCTIONS

After bucket has been lowered to overnight storage position, move all switches and controls to "OFF" position. Pull parking brake knob to "APPLIED" position. This will apply parking brake. Move pilot cutoff switch to "LOCK" position. This will disable pilot control valve lever (joystick). Move key in starter switch to "OFF" position, and remove key from switch.

Engage all lock-down security equipment that may have been installed on machine.

IMPORTANT

When hydraulic system maintenance or service work must be performed, be aware that accumulators in system store fluid under pressure after system has been shut down. To release hydraulic pressure in accumulators, operate control with engine "OFF" until accumulator pressure is completely dissipated.

NEVER LET ANYONE RIDE ON ATTACHMENT

Never let anyone ride on any work attachment, such as the bucket, crusher, grapple, or clamshell (grab bucket). There is a danger of the person falling and suffering serious injury.



Figure 21

MAINTENANCE

USE WARNING TAG DURING SERVICE

Alert others that service or maintenance is being performed and tag operator's cab controls - and other machine areas if required - with a warning notice.

Warning tags for controls are available from distributors; see Figure 22.



Figure 22

CLEAN BEFORE INSPECTION OR MAINTENANCE

Clean the machine before carrying out inspection and maintenance. This prevents dirt from getting into the machine and also ensures safety during maintenance.

If inspection and maintenance are carried out when the machine is dirty, it will become more difficult to locate the problems, and also there is danger that you may get dirt or mud in your eyes or that you may slip and injure yourself.

When washing the machine, do the following;

- Wear shoes with nonslip soles to prevent yourself from slipping and falling on wet places.
- Wear safety glasses and protective clothing when washing the machine with high-pressure steam.
- Take action to prevent touching high-pressure water and cutting your skin or having mud fly into your eyes.
- Do not spray water directly on electrical components (sensors, connector) (1, Figure 23). If water gets into the electrical system, there is danger that it will cause defective operation and malfunction.

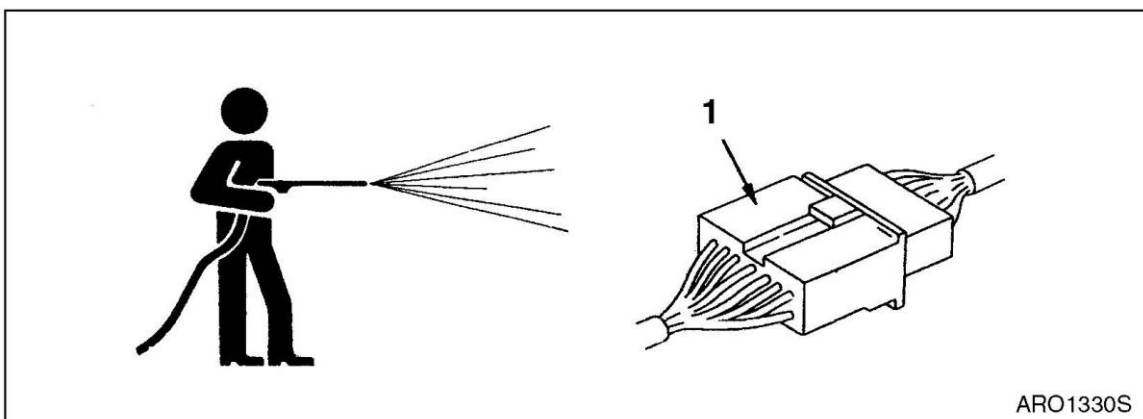

Figure 23

Pick up any tools or hammers that are laying in the work place, wipe up any grease or oil or any other slippery substances, and clean the area to make it possible to carry out the operation in safety. If the work place is left untidy, you may trip or slip and suffer injury.

PROPER TOOLS

Use only tools suited to the task. Using damaged, low quality, faulty, or makeshift tools could cause personal injury. There is danger that pieces from, chisels with crushed heads, or hammers, may get into your eyes and cause blindness.

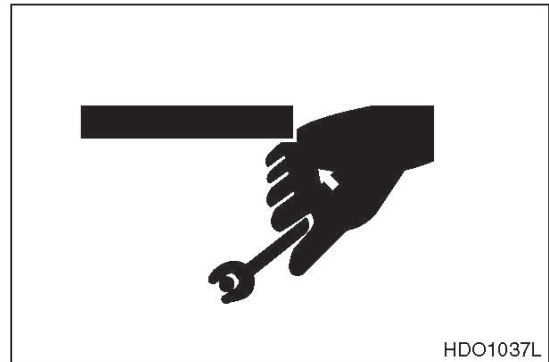

Figure 24

USE OF LIGHTING

When checking fuel, oil, battery electrolyte, or window washing fluid, always use lighting with anti-explosion specifications. If such lighting equipment is not used, there is danger of explosion.

If work is carried out in dark places without using lighting, it may lead to injury, so always use proper lighting.

Even if the place is dark, never use a lighter or flame instead of lighting. There is danger of fire.

There is also danger that the battery gas may catch fire and cause an explosion.

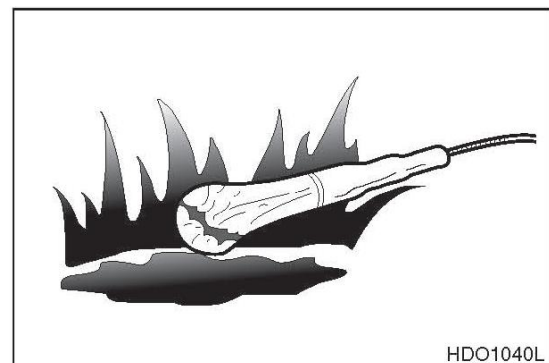

Figure 25

FIRE PREVENTION AND EXPLOSION PREVENTION

All fuels, most lubricants and some coolant mixtures are flammable. Leaking fuel or fuel that is spilled onto hot surfaces or onto electrical components can cause a fire.

Store all fuels and all lubricants in properly marked containers and away from all unauthorized persons.

Store oily rags and other flammable material in a protective container.

Do not smoke while you refuel the machine or while you are in a refueling area.

Do not smoke in battery charging areas or in areas that contain flammable material.

Clean all electrical connections and tighten all electrical connections. Check the electrical wires daily for wires that are loose or frayed. Tighten all loose electrical wires before you operate the machine. Repair all frayed electrical wires before you operate the machine.

Remove all flammable materials before they accumulate on the machine.

Do not weld on pipes or on tubes that contain flammable fluids. Do not flame cut on pipes or on tubes that contain flammable fluids. Before you weld on pipes or on tubes or before you flame cut on pipes or on tubes, clean the pipes or tubes thoroughly with a nonflammable solvent.

BURN PREVENTION

When checking the radiator coolant level, shut down engine, let the engine and radiator cool down, then check the coolant recovery tank. If the coolant level in the coolant recovery tank is near the upper limit, there is enough coolant in the radiator.

Loosen the radiator cap gradually to release the internal pressure before removing the radiator cap.

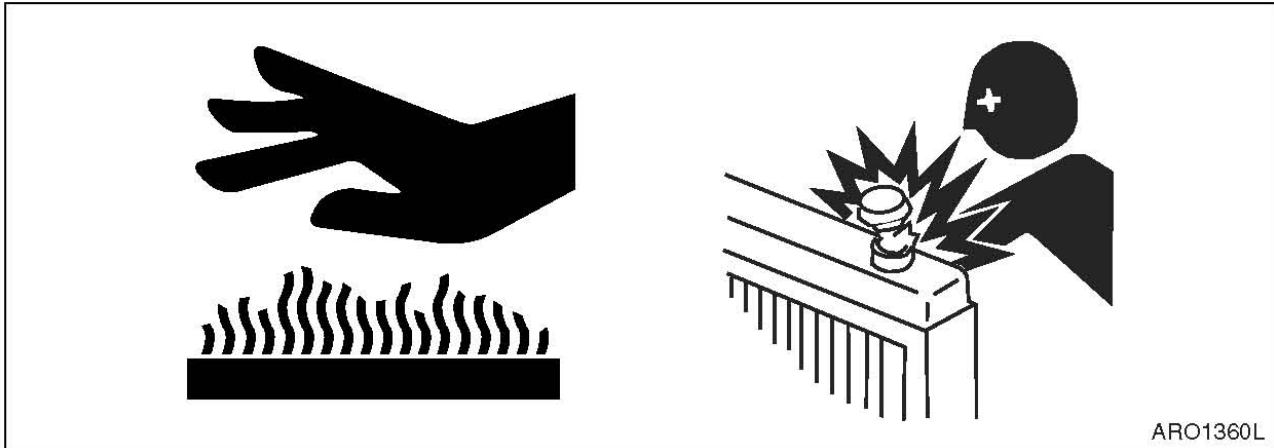

Figure 26

If the coolant level in the coolant recovery tank is below the lower limit, add coolant.

Cooling system conditioner contains alkali. Alkali can cause personal injury. Do not allow alkali to contact the skin, the eyes, or the mouth.

Allow cooling system components to cool before you drain the cooling system.

Hot oil and hot components can cause personal injury. Do not allow hot oil or hot components to contact the skin.

Remove the hydraulic tank filter plug only after the engine has been stopped. Make sure that the hydraulic tank filter plug is cool before you remove it with your bare hand. Remove the hydraulic tank filter plug slowly to relieve pressure.

Relieve all pressure in the hydraulic oil system, in the fuel system, or in the cooling system before you disconnect any lines, fittings, or related items.

Batteries give off flammable fumes that can explode.

Do not smoke while you are checking the battery electrolyte levels.

Electrolyte is an acid. Electrolyte can cause personal injury. Do not allow electrolyte to contact the skin or the eyes.

Always wear protective glasses when you work on batteries.

WELDING REPAIRS

When carrying out welding repairs, carry out the welding in a properly equipped place. The welding should be performed by a qualified worker. During welding operations, there is the danger of, generation of gas, fire, or electric shock, so never let an unqualified worker do welding.

The qualified welder must do the following;

- To prevent explosion of the battery, disconnect the battery terminals and remove batteries.
- To prevent generation of gas, remove the paint from the location of the weld.
- If hydraulic equipment, piping or places close to them are heated, a flammable gas or mist will be generated and there is danger of it catching fire. To avoid this, never subject these places to heat.
- Do not weld on pipes or on tubes that contain flammable fluids. Do not flame cut on pipes or on tubes that contain flammable fluids. Before you weld on pipes or on tubes or before you flame cut on pipes or on tubes, clean the pipes or tubes thoroughly with a nonflammable solvent.
- If heat is applied directly to rubber hoses or piping under pressure, they may suddenly break so cover them with a fireproof covering.
- Wear protective clothing.
- Make sure there is good ventilation.
- Remove all flammable objects and provide a fire extinguisher.

PRECAUTIONS FOR REMOVAL, INSTALLATION, AND STORAGE OF ATTACHMENTS

Before starting removal and installation of attachments, decide the team leader.

Do not allow anyone except the authorized workers close to the machine or attachment.

Place attachments that have been removed from the machine in a safe place so that they do not fall.

Put up a fence around the attachments and take other measures to prevent unauthorized persons from entering.

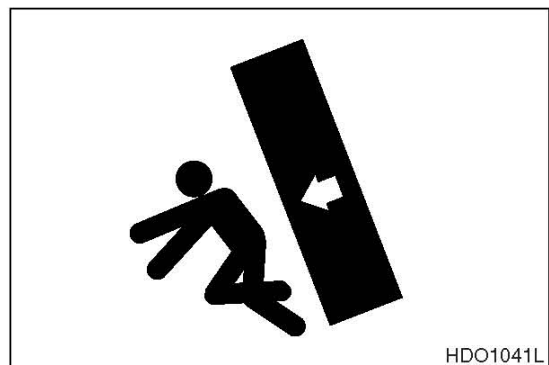

Figure 27

PRECAUTIONS WHEN WORKING ON MACHINE

When carrying out maintenance operations on the machine, keep the area around your feet clean and tidy to prevent you from falling.

Always do the following;

- Do not spill oil or grease.
- Do not leave tools laying about.
- Watch your step when walking.



Figure 28

Never jump down from the machine. When getting on or off the machine, use the steps and handrails, and maintain a three-point contact (both feet and one hand or both hands and one foot) to support yourself securely.

If the job requires it, wear protective clothing.

To prevent injury from slipping or falling, when working on the hood or covers, never use any part except the inspection passage fitted with nonslip pads.

LOCK INSPECTION COVERS

When carrying out maintenance with the inspection cover open, lock the cover securely in position with the lock bar.

If maintenance work is carried out with the inspection cover open but not locked, there is danger that it may suddenly close and cause injury if there is a gust of wind.

CRUSHING PREVENTION AND CUTTING PREVENTION

You should always have at least two people working together if the engine must be run during service. One person needs to remain in the operator's seat, ready to work the controls or stop the machine and shut off the engine.

Unless you are instructed otherwise, never attempt adjustments while the machine is moving or while the engine is running.

Stay clear of all rotating parts and moving parts.

Keep objects away from moving fan blades. The fan blades will throw objects and the fan blades can cut objects.

Do not use a wire rope cable that is kinked or frayed. Wear gloves when you handle a wire rope cable.

When you strike a retainer pin, the retainer pin might fly out. The loose retainer pin can injure personnel.

Make sure that the area is clear of people when you strike a retainer pin. To avoid injury to your eyes, wear protective glasses when you strike a retainer pin.

DO NOT RUN ENGINE IF REPAIRS OR WORK ARE BEING PERFORMED ALONE

You should always have at least two people working together if engine must be run during service. One person needs to remain in operator's seat, ready to work controls or stop machine and shut "OFF" engine.

ALWAYS USE ADEQUATE EQUIPMENT SUPPORTS AND BLOCKING

Do not allow weight or equipment loads to remain suspended. Lower everything to ground before leaving operator's seat. Do not use hollow, cracked or unsteady, wobbling weight supports. Do not work under any equipment supported solely by a lift jack.

DO NOT WORK ON HOT ENGINES OR HOT COOLING OR HYDRAULIC SYSTEMS

Wait for engine to cool off after normal operation. Park wheel loader on firm, level ground and lower all equipment before shutting down and switching "OFF" controls. When engine lube oil, gearbox lubricant or other fluids require change, wait for fluid temperatures to decrease to a moderate level before removing drain plugs.

NOTE: *Oil will drain more quickly and completely if it is warm. Do not drain fluids at temperatures exceeding 95°C (203°F), however do not allow full cool down.*

HYDRAULIC CYLINDER SEALS REQUIRE PERIODIC REPLACEMENT

Check cylinder drift rate at regular intervals.

HIGH PRESSURE HYDRAULIC LINES CAN STORE A GREAT DEAL OF ENERGY

Exposed hydraulic hoses on arm or boom could react with explosive force if struck by a falling rock, overhead obstacle or other work site hazard. Extra safety guards may be required. NEVER allow hoses to be hit, bent or interfered with during operation.

PRECAUTIONS WITH HIGH PRESSURE LINE, TUBES AND HOSES

When inspecting or replacing high-pressure piping or hoses, check that the pressure has been released from the circuit. Failure to release the pressure may lead to serious injury. Always do the following;

- Wear protective glasses and leather gloves.
- Fluid leaks from hydraulic hoses or pressurized components can be difficult to see but pressurized oil has enough force to pierce the skin and cause serious injury. Always use a piece of wood or cardboard to check for suspected hydraulic leaks. Never use your hands or expose your fingers.
- Do not bend high pressure lines. Do not strike high pressure lines. Do not install lines, tubes or hoses that are bent or damaged.
- Make sure that all clamps, guards and heat shields are installed correctly to prevent vibration, rubbing against other parts, and excessive heat during operation.
 - If any of the following conditions are found, replace the part.
 - Damage or leakage from hose end.
 - Wear, damage, cutting of covering, or exposure of strengthening wire layer.
 - Cover portion is swollen in places.
 - There is twisting or crushing at movable parts of hose.
 - Foreign material is embedded in the covering.
 - Hose end is deformed.

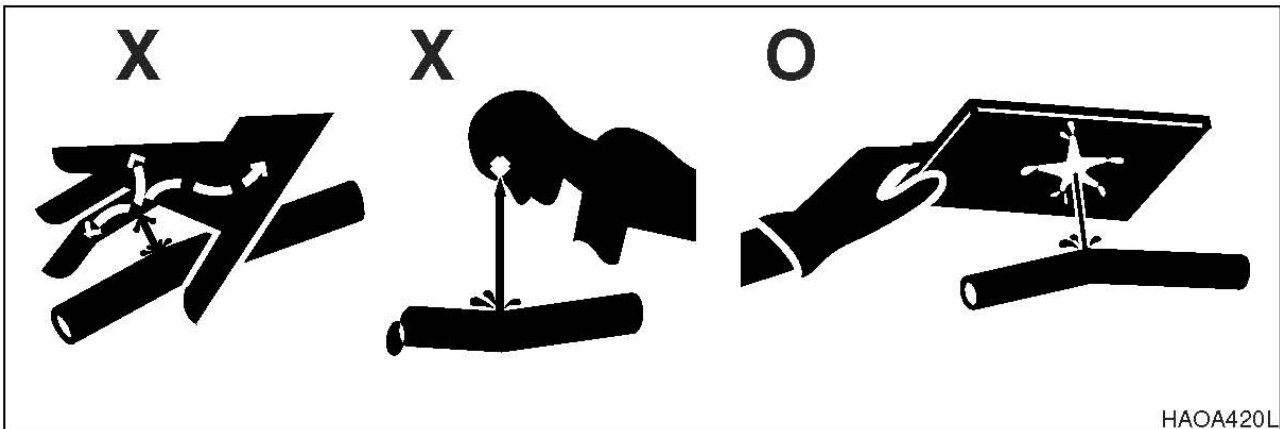

Figure 29

OBTAIN IMMEDIATE MEDICAL ATTENTION IF PRESSURIZED OIL PIERCES SKIN.

⚠ WARNING!

Failure to obtain prompt medical assistance could result in gangrene or other serious damage to tissue.

USE CORRECT REPLACEMENT FASTENERS TIGHTENED TO PROPER TORQUE

Refer to "General Maintenance" section of Shop Manual for information on tightening torques and recommended assembly compounds and always use correct part.

Poor or incorrect fastener connections can dangerously weaken assemblies.

SAFETY-CRITICAL PARTS MUST BE REPLACED PERIODICALLY

Replace following fire-related components as soon as they begin to show any sign of wear, or at regular periodic intervals, whether or not deterioration is visible:

- Fuel system flexible hoses, the tank overflow drain hose and the fuel filler cap.
- Hydraulic system hoses, especially the pump outlet lines and front and rear pump branch hoses.
- Keep mounting brackets and hose and cable routing straps tight. Hose routing should have gradual bends.

DISPOSE OF ALL PETROLEUM-BASED OILS AND FLUIDS PROPERLY

Physical contact with used motor oil may pose a health risk. Wipe oil from your hands promptly and wash off any remaining residue.

Used motor oil is an environmental contaminant and may only be disposed of at approved collection facilities. To prevent pollution of the environment, always do the following;

- Never dump waste oil in a sewer system, rivers, etc.
- Always put oil drained from your machine in containers. Never drain oil directly onto the ground.
- Obey appropriate laws and regulations when disposing of harmful materials such as oil, fuel, solvent, filters, and batteries.

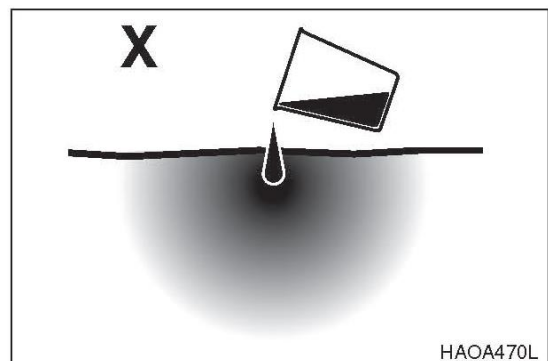

Figure 30

CHECK TIRE PRESSURE AND CONDITION

Maintain tire pressure but do not over inflate. Inspect tires and wheels daily. When inflating tires, follow procedures in Maintenance Section, which include using an extension to allow you to avoid standing in front of or over a tire. Do not change a tire unless you have both experience and proper equipment.

BATTERY HAZARD PREVENTION

Battery electrolyte contains diluted sulfuric acid and batteries generate hydrogen gas. Hydrogen gas is highly explosive, and mistakes in handling them can cause serious injury or fire. To prevent problems, always do the following;

- Do not smoke or bring any flame near the battery.
- When working with batteries, ALWAYS wear safety glasses and rubber gloves.
- If you spill battery electrolyte on yourself or your clothes, immediately flush the area with water.
- If battery electrolyte gets into your eyes, flush them immediately with large quantities of water and see a doctor at once.
- If you accidentally drink battery electrolyte, drink a large quantity of water or milk, raw egg or vegetable oil. Call a doctor or poison prevention center immediately.
- When cleaning the top surface of the battery, wipe it with a clean, damp cloth. Never use gasoline, thinner, or any other organic solvent or detergent.
- Tighten the battery caps securely.
- Explosive battery gas can be set off by sparks from incidental contact or static discharge. Turn "OFF" all switches and engine when working on batteries. Keep battery terminals tight. Contact between a loose terminal and post can create an explosive spark.
- If the battery electrolyte is frozen, do not charge the battery or start the engine with power from another source. There is danger that the battery may catch fire.
- When charging the battery or starting with power from another source, let the battery electrolyte melt and check that there is no leakage of battery electrolyte before starting the operation.
- Always remove the battery from the machine before charging.

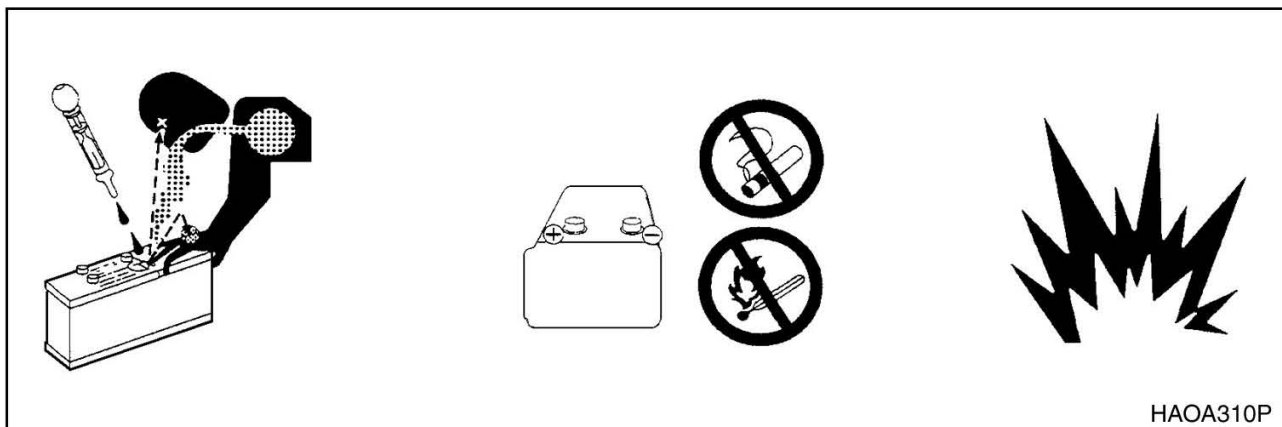

Figure 31

DISCONNECT BATTERIES BEFORE ELECTRICAL SERVICE OR ELECTRICAL WELDING

Remove cable to negative terminal first when disconnecting cable. Connect positive terminal cables first when installing a battery.

USE LOW HEAT PORTABLE LIGHTING

Hot surfaces on trouble lights or portable work lights can set off fuel or battery explosive gases.

BOOST STARTING OR CHARGING ENGINE BATTERIES

If any mistake is made in the method of connecting the booster cables, it may cause an explosion or fire.

Always do the following;

- Turn off all electrical equipment before connecting leads to the battery. This includes electrical switches on the battery charger or boost starting equipment.
- When boost-starting from another machine or vehicle do not allow the two machines to touch. Wear safety glasses or goggles while required battery connections are made.
- 24 volt battery units consisting of two series-connected twelve volt batteries have a cable connecting one positive terminal on one of the 12 volt batteries to a negative terminal on the other battery. Booster or charger cable connections must be made between the nonseries-connected positive terminals and between the negative terminal of the booster battery and the metal frame of the machine being boosted or charged. Refer to the procedure and illustration in Operation and Maintenance Manual.
- Connect positive cable first when installing cables and disconnect the negative cable first when removing them. The final cable connection, at the metal frame of the machine being charged or boost-started, should be as far away from the batteries as possible.

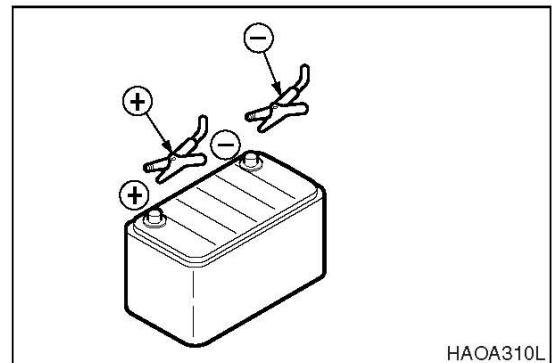

Figure 32

TOWING

PRECAUTIONS WHEN TOWING

If any mistake is made in the method of selecting or inspecting the towing wire or in the method of towing, it may lead to serious personal injury. Always do the following;

- Always use the method of towing given in this Operation and Maintenance Manual. Do not use any other method.
- Use leather gloves when handling the wire rope.
- When carrying out the preparation work for towing with two or more workers, determine the signals to use and follow these signals correctly.
- If the engine on the problem machine will not start or there is a failure in the brake system, always contact your DISD distributor.
- Never go between the towing machine and the towed machine during the towing operation.
- It is dangerous to carry out towing on slopes, so select a place where the slope is gradual. If there is no place where the slope is gradual, carry out operations to reduce the angle of the slope before starting the towing operation.
- When towing a problem machine, always use a wire rope with a sufficient towing capacity.
- Do not use a frayed, kinked rope or a rope with any loss of diameter.

SHIPPING AND TRANSPORTATION

OBEY STATE AND LOCAL OVER-THE-ROAD REGULATIONS

Check state and local restrictions regarding weight, width and length of a load before making any other preparation for transport.

Hauling vehicle, trailer and load must all be in compliance with local regulations governing intended shipping route.

Partial disassembly or tear-down of wheel loader may be necessary to meet travel restrictions or particular conditions at work site.

Refer to the section "Transportation" section of operation manual.

SUMMARY OF SAFETY PRECAUTIONS FOR LIFTING

WARNING!

Improper lifting can allow load to shift and cause personal injury or damage to the machine

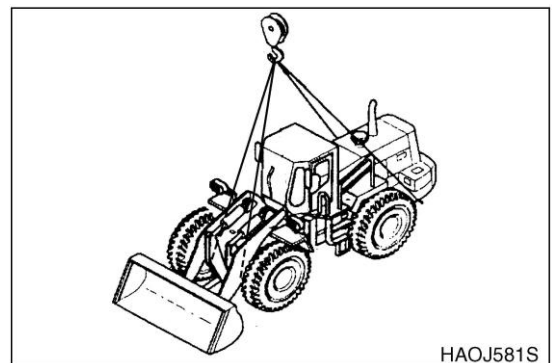

Figure 33

To make safe lifts, the following items must be evaluated by operator and work site crew.

- Condition of ground support.
- Wheel loader configuration and attachments.
- Weight, lifting height and lifting radius.
- Safe rigging of load.
- Proper handling of suspended load.

Taglines on opposite sides of load can be very helpful in keeping a suspended load secure, if they are anchored safely to control points on ground.

SPECIFICATIONS

SPECIFICATIONS

 **CAUTION!**

Follow all safety recommendations and safe shop practices outlined in the front of this manual or those contained within this section.

Always use tools and equipment that is in good working order.

Use lifting and hoisting equipment capable of safely handling load.

Remember, that ultimately safety is your own personal responsibility.

TABLE OF CONTENTS

Component Locations	3
General Specifications	5
Engine Performance Curves	6
Working Range and Dimensions.....	8
Working Capacities	9
Bucket Capacity	9
Tipping Load	9
Material Weight	9
Approximate Weight of Workload Materials	9

COMPONENT LOCATIONS

Figure 1 identifies the location of major machine components.

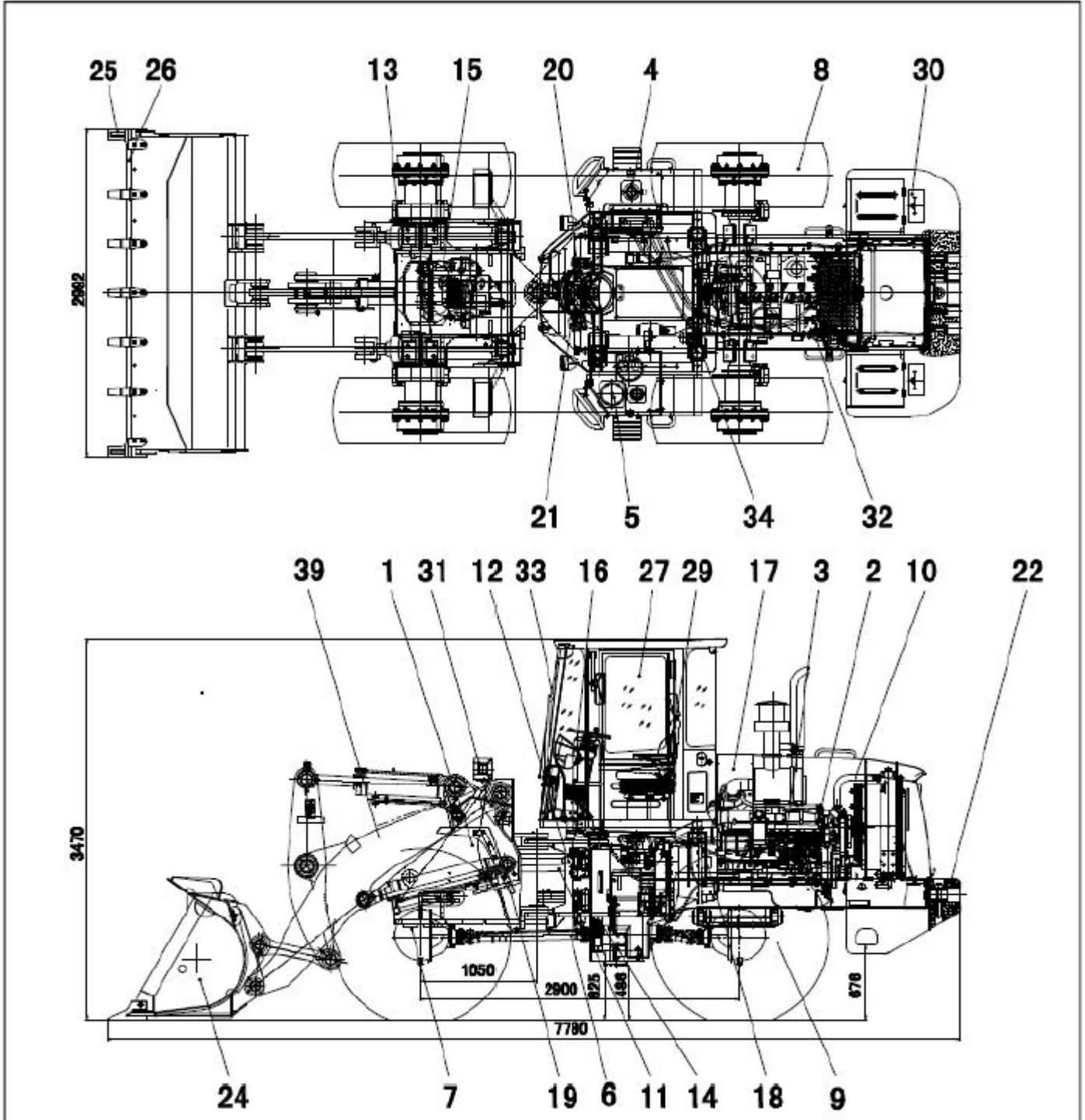

Figure 1

Reference Number	Description	Reference Number	Description
1	Frame	18	Cabin Seat
2	E/G and T/M Ass'y	19	Fender
3	Engine control	20	Pedal
4	Fuel Tank	21	Stop
5	Oil tank	22	Counterweight
6	Driving shaft	24	Bucket module
7	Axle	25	Bucket lip
8	Tire	26	Bucket knifing edge
9	Tire hub	27	Cab
10	Cooling Pipe line	29	Seat
11	Main Pipe line	30	Lighting lamp-rear
12	Steering Pipe line	31	Lighting lamp-front
13	Brake Pipe line	32	Electrical part-engine
14	Parking System	33	Electrical part-cab
15	Main Control Valve	34	Electrical par-electrical box
16	Handrail	39	nameplate
17	Cover		

GENERAL SPECIFICATIONS

Item		
Serial Number		
Standard Bucket Capacity		2.70 m ³
Vehicle Weight		17,000 kg (37,479 lb)
Engine		
	Type	Weichai
	Rated power (SAE J 1995 gross)	220 ps @ 2,000 rpm (217 hp @ 2,000 rpm)
	Max. Torque (SAE J 1995 gross)	92 kg•m / 1,300 rpm (666 ft lb @ 1,300 rpm)
Transmission		
	Mechanical gear shift	Mechanical gear shift
	Speeds	2 Forward, 1 Reverse
Brake Systems		
	Service Brakes	4 Wheel, Dry Disks, Single Pedal
	Parking Brake	Dry Disc on Transmission
Performance		
	Travel Speed (1 / 2)	13 (8.1) / 38 (23.6) km/h (mph)
	Steering Angle	+ 40°
	Min. Tire Turning Radius (Tire Center)	5,073 mm
	Max. Tractive Effort	16,400 kg (36,156 lb)
	Max. Breakout Force	16,300kg (35,936 lb)
	Bucket Rise Time	5.3Seconds
	Bucket Dump Time	1.3 Seconds
	Bucket Descent Time	3.6Seconds
Working Range		
	Dump Height at 45° (w/o teeth)	3,030 mm (10' - 3")
	Dump Reach at 45° (w/o teeth)	1,330 mm (3' - 5")
	Max Dump Angle at Fully Raised	48°
	Max Tilt Angle at Carry	45°
Travel Dimension		
	Overall Length	7,780 mm (26' - 6")
	Overall Width	2,992 mm (9' - 8")
	Overall Height	3,470 mm (11' - 5")
	Wheel Base	2,900 mm (10' - 6")
	Tread	2,150 mm (7' - 0")
	Ground Clearance	480 mm (1' - 6")

ENGINE PERFORMANCE CURVES

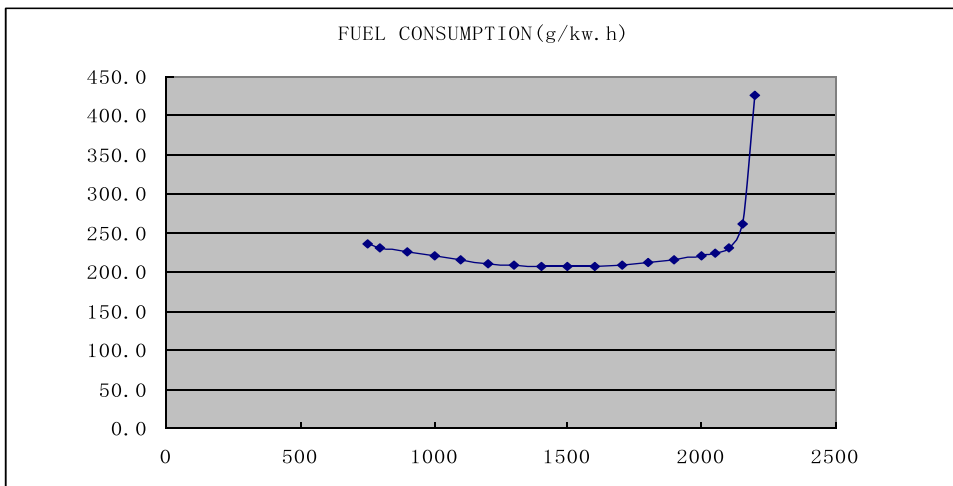
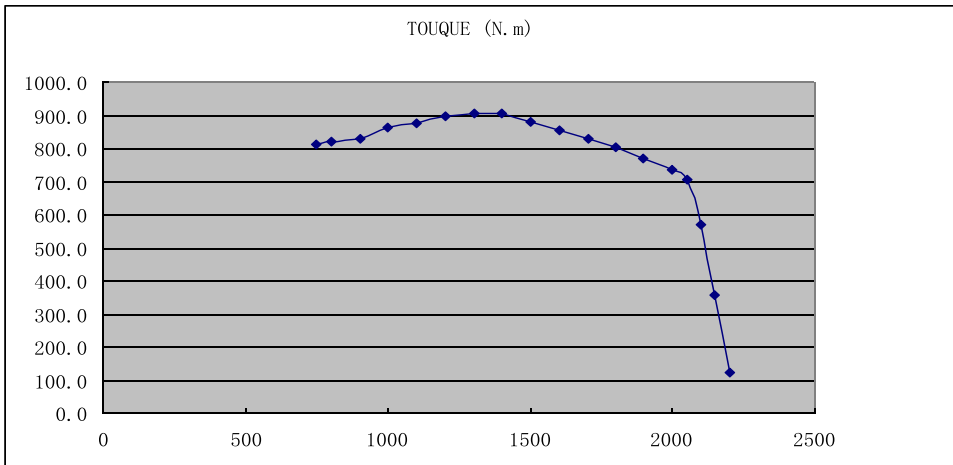
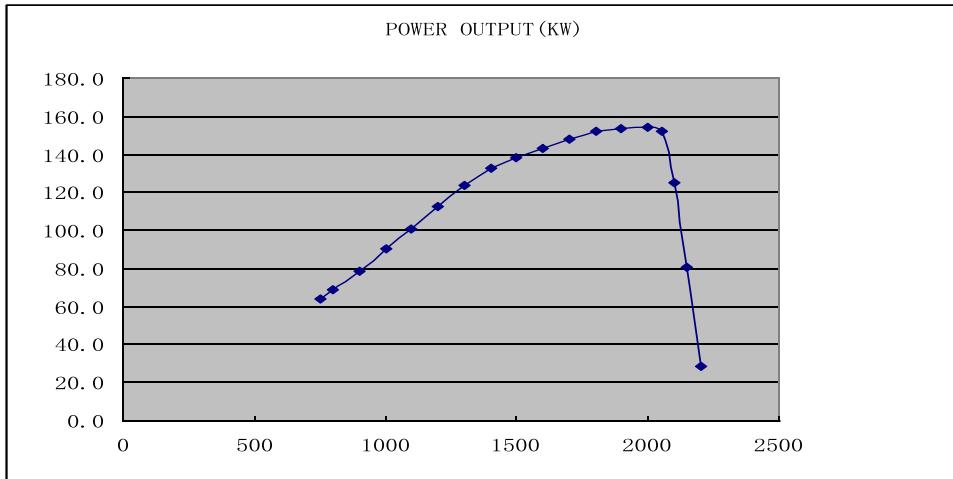

Serial Number	
Engine Type	WD10G220E23
Rated Power (217 hp @ 2,000 rpm)	220 ps @ 2,000 rpm (217 hp @ 2,200 rpm)
Maximum Torque (666 ft lb @ 1,300 rpm)	92 kg•m @ 1,300 rpm (666 ft lb @ 1,300 rpm)
Fuel Consumption	225 g/kw.h
Performance Standard	SAE J1349

NOTE: *Barometric Pressure: 760 mm (30") Mercury*

Temperature: 20°C (68°F)

W/O Cooling Fan: Driven by engine

Alternator: 24 V, 50 amp

Exhaust System: Complete, attached

Air Cleaner; Installed

WORKING RANGE AND DIMENSIONS

Figure 3, illustrates exterior machine dimensions and working range of machine when it is equipped with a standard bucket.

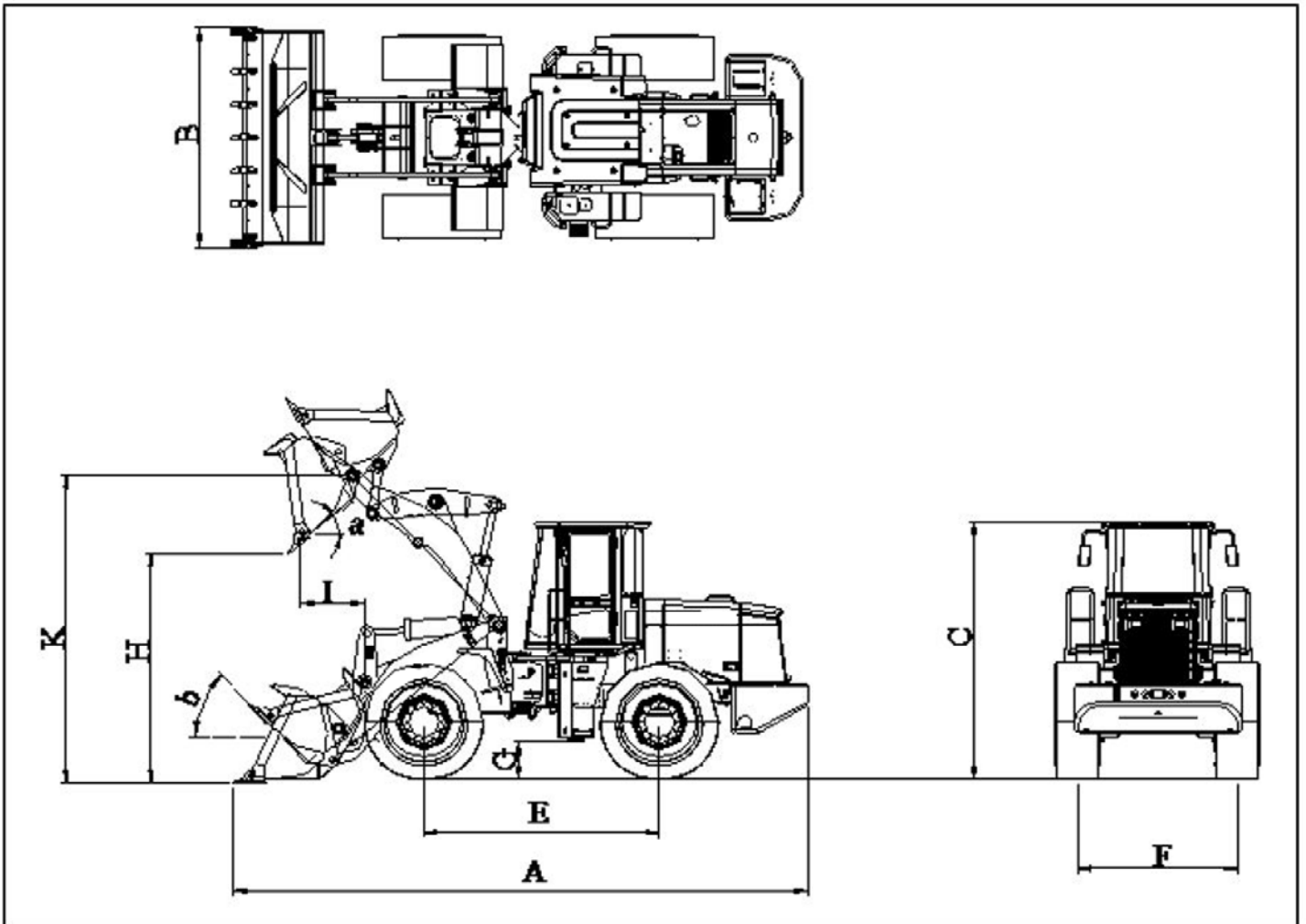

Figure 3

Category	Dimension	Category	Dimension
Overall Length (A)	7,780 mm (25' 5")	Dump Height, to tooth (H)	3,030 mm (10' - 3")
Overall Width (B)	2,992 mm (9' 8")	Dump Distance, to Bucket Edge (I)	1,330mm (3' 5")
Overall Height (C)	3,470 mm (11' 5")	Dump Height to Bucket Pivot (K)	4,100 mm (13'7")
Wheel Base (E)	2,900 mm (9' 5")	Max. Dump Angle at Fully Raised (a)	48°
Tread (F)	2,150 mm (7' 0")	Max. Tilt Angle at Carry (b)	45°
Ground Clearance (G)	480 mm (1' 6")	Tire Size	23.5-25-16 PR(L3)

WORKING CAPACITIES

BUCKET CAPACITY

Standard toothed bucket has a capacity of 2.9 m³ (3.8 yd³). An optional bucket equipped with a cutting edge and no teeth has a capacity of 2.7 m³

TIPPING LOAD

Static Tipping Load with bucket at max reach position is 10,600 kg (23,369 lb). With bucket in Fully Turned position, Static Tipping Load is 9,500 kg (29,944lb).

MATERIAL WEIGHT

The data below describes weight of a cubic meter (cubic yard) of many types of workload materials.

APPROXIMATE WEIGHT OF WORKLOAD MATERIALS

MATERIAL	LOW WEIGHT OR DENSITY 1,100 KG/M ³ (1,850 LB/YD ³), OR LESS	MEDIUM WEIGHT OR DENSITY 1,600 KG/M ³ (2,700 LB/YD ³), OR LESS	HIGH WEIGHT OR DENSITY 2,000 KG/M ³ (3,370 LB/YD ³), OR LESS
Charcoal	401 kg/m ³ (695 lb/yd ³)	-----	-----
Coke, blast furnace size	433 kg/m ³ (729 lb/yd ³)	-----	-----
Coke, foundry size	449 kg/m ³ (756 lb/yd ³)	-----	-----
Coal, bituminous slack, piled	801 kg/m ³ (1,350 lb/yd ³)	-----	-----
Coal, bituminous r. of m., piled	881 kg/m ³ (1,485 lb/yd ³)	-----	-----
Coal, anthracite	897 kg/m ³ (1,512 lb/yd ³)	-----	-----
Clay, DRY, in broken lumps	1,009 kg/m ³ (1,701 lb/yd ³)	-----	-----
Clay, DAMP, natural bed	-----	1,746 kg/m ³ (2,943 lb/yd ³)	-----

MATERIAL	LOW WEIGHT OR DENSITY 1,100 KG/M³ (1,850 LB/YD³), OR LESS	MEDIUM WEIGHT OR DENSITY 1,600 KG/M³ (2,700 LB/YD³), OR LESS	HIGH WEIGHT OR DENSITY 2,000 KG/M³ (3,370 LB/YD³), OR LESS
Cement, Portland, DRY granular	-----	1,506 kg/m ³ (2,583 lb/yd ³)	-----
Cement, Portland, DRY clinkers	-----	1,362 kg/m ³ (2,295 lb/yd ³)	-----
Dolomite, crushed	-----	1,522 kg/m ³ (2,565 lb/yd ³)	-----
Earth, loamy, DRY, loose	-----	1,202 kg/m ³ (2,025 lb/yd ³)	-----
Earth, DRY, packed	-----	1,522 kg/m ³ (2,565 lb/y d ³)	-----
Earth, WET, muddy	-----	-----	1,762 kg/m ³ (2,970 lb/yd ³)
Gypsum, calcined, (heated, powder)	961kg/m ³ (1,620 lb/yd ³)	-----	-----
Gypsum, crushed to 3 inch size	-----	1,522 kg/m ³ (2,565 lb/y d ³)	-----
Gravel, DRY, packed fragments	-----	-----	1,810 kg/m ³ (3,051 lb/y d ³)
Gravel, WET, packed fragments	-----	-----	1,522 kg/m ³ (3,240 lb/y d ³)
Limestone, graded above 2	-----	1,282 kg/m ³ (2,160 lb/y d ³)	-----
Limestone, graded 1-1/2 or 2	-----	1,362 kg/m ³ (2,295 lb/y d ³)	-----
Limestone, crushed	-----	1,522 kg/m ³ (2,565 lb/y d ³)	-----
Limestone, fine	-----	-----	1,602 kg/m ³ (2,705 lb/y d ³)
Phosphate, rock	-----	1,282 kg/m ³ (2,160 lb/y d ³)	-----

MATERIAL	LOW WEIGHT OR DENSITY 1,100 KG/M³ (1,850 LB/YD³), OR LESS	MEDIUM WEIGHT OR DENSITY 1,600 KG/M³ (2,700 LB/YD³), OR LESS	HIGH WEIGHT OR DENSITY 2,000 KG/M³ (3,370 LB/YD³), OR LESS
Salt	929 kg/m ³ (1,566 lb/yd ³)	-----	-----
Snow, light density	529 kg/m ³ (891 lb/yd ³)	-----	-----
Sand, DRY, loose	-----	1,522 kg/m ³ (2,565 lb/yd ³)	-----
Sand, WET, packed	-----	-----	1,922 kg/m ³ (3,240 lb/yd ³)
Shale, broken	-----	1,362 kg/m ³ (2,295 lb/y d ³)	-----
Sulphur, broken	529 kg/m ³ (891 lb/yd ³)	-----	-----

IMPORTANT

Weights are approximations of estimated average volume and mass. Exposure to rain, snow or ground water; settling or compaction due to overhead weight and chemical or industrial processing or changes due to thermal or chemical transformations could all increase value of weights listed in table..

GENERAL MAINTENANCE

GENERAL MAINTENANCE PROCEDURES

CAUTION!

Follow all safety recommendations and safe shop practices outlined in the front of this manual or those contained within this section.

Always use tools and equipment that is in good working order.

Use lifting and hoisting equipment capable of safely handling load.

Remember, that ultimately safety is your own personal responsibility.

TABLE OF CONTENTS

Welding Precautions and Guidelines	3
Hydraulic System - General Precautions	4
Maintenance Service and Repair Procedure	5
General Precautions	5
Hydraulic System Cleanliness and Oil Leaks.....	6
Maintenance Precautions for Hydraulic System Service	6
Oil Leakage Precautions.....	6
Cleaning and Inspection.....	7
General Guidelines	7
Bearing inspection	8

WELDING PRECAUTIONS AND GUIDELINES

IMPORTANT

To avoid accidents, personal injury and the possibility of causing damage to the machine or to components, welding must only be performed by properly trained and qualified personnel, who possess the correct certification (when required) for the specific welding fabrication or specialized repair being performed.

WARNING!

Structural elements of the machine may be built from a variety of steels. These could contain unique alloys or may have been heat treated to obtain particular strength characteristics. It is extremely important that welding repairs on these types of steel are performed with the proper procedures and equipment. If repairs are performed incorrectly, structural weakening or other damage to the machine (that is not always readily visible) could be caused. Always consult DISD After Sales Service before welding on integral components (loader arm, frames, car body, track frames, turntable, attachment, etc.) of the machine. It is possible that some types of structurally critical repairs may require Magnetic Particle or Liquid Penetrant testing, to make sure there are no hidden cracks or damage, before the machine can be returned to service.

CAUTION!

Always perform welding procedures with the proper safety equipment on hand. Adequate ventilation and a dry work area are absolutely essential. Keep a fire extinguisher nearby and always wear protective clothing and the recommended type of eye protection.

CAUTION!

Observe the following safety precautions:

1. Use extra caution and adequate safety shielding when welding near fuel and oil tanks, batteries, hydraulic piping lines or other fire hazards.
2. Never weld when the engine is running. Battery cables must be disconnected before the welding procedure is started.
3. Never weld on a wet or damp surface. The presence of moisture causes hydrogen embrittlement and structural weakening of the weld.
4. If welding procedures are being performed near cylinder rods, operator's cab window areas or any other assemblies that could be damaged by weld spatters, use adequate shielding protection in front of the assembly.
5. During equipment setup, always attach ground cables directly to the area or component being welded to prevent arcing through bearings, bushings, or spacers.
6. Always use correct welding rods for the type of weld being performed and observe recommended precautions and time constraints. AWS Class E7018 welding rods for low alloy to medium carbon steel must be used within two hours after removal from a freshly opened container. Class E11018G welding rods for T-1 and other higher strength steel must be used within 1/2 hour.

HYDRAULIC SYSTEM - GENERAL PRECAUTIONS

Always maintain oil level in the system at recommended levels. Assemblies that operate under heavy loads, at high speed, with extremely precise dimensional tolerances between moving parts - pistons and cylinders, or shoes and swash plates, for example - can be severely damaged if oil supply runs dry.

Assemblies can be run dry and damaged severely in a very short time when piping or hoses are disconnected to repair leaks and/or replace damaged components. Hoses that are inadvertently switched during disassembly (inlet for outlet and vice versa), air introduced into the system or assemblies that are low on oil due to neglect or careless maintenance, could all produce sufficient fluid loss to cause damage.

When starting the engine (particularly after long layoff or storage intervals), make sure that all hydraulic controls and operating circuits are in neutral, or "OFF." That will prevent pumps or other components that may be temporarily oil-starved from being run under a load.

Replacement of any hydraulic system component could require thorough cleaning, flushing, and some amount of pre-filling with fresh, clean oil if the protective seal on replacement parts has obviously been broken or if seal integrity may have been compromised. When protective seals are removed before installation and reassembly, inspect all replacement parts carefully, before they are installed. If the replacement part is bone dry (with no trace of factory pre-lube) or has been contaminated by dirt or by questionable oils, flushing and pre-filling with clean hydraulic fluid is recommended.

Vibration, irregular or difficult movement or unusual noise from any part of the hydraulic system could be an indication of air in the system (and many other types of problems). As a general precaution (and to help minimize the risk of potential long-term damage), allow the engine to run at no-load idle speed immediately after initial start-up. Hydraulic fluid will circulate, releasing any air that may have been trapped in the system before load demands are imposed.

A daily walk-around pre-start equipment safety inspection, including a quick visual scan for any exterior evidence of leaking hydraulic fluid, can help extend the service life of system components.

IMPORTANT

Hydraulic system operating conditions (repetitive cycling, heavy work loads, fluid circulating under high pressure) make it extremely critical that dust, grit or any other type of contamination be kept out of the system. Observe fluid and filter change maintenance interval recommendations and always pre-clean any exterior surface of the system before it is exposed to air. For example, the reservoir filler cap and neck area, hoses that have to be disassembled, and the covers and external surfaces of filter canisters should all be cleaned before disassembly.

MAINTENANCE SERVICE AND REPAIR PROCEDURE

GENERAL PRECAUTIONS

Fluid level and condition should always be checked whenever any other type of maintenance service or repair is being performed.

NOTE: *If the unit is being used in an extreme temperature environment (in sub-freezing climates or in high temperature, high humidity tropical conditions), frequent purging of moisture condensation from the hydraulic reservoir drain tap should be a regular and frequent part of the operating routine. In more moderate, temperate climates, draining reservoir sediment and moisture may not be required more than once or twice every few months.*

Inspect drained oil and used filters for signs of abnormal coloring or visible fluid contamination at every oil change. Abrasive grit or dust particles will cause discoloration and darkening of the fluid. Visible accumulations of dirt or grit could be an indication that filter elements are overloaded (and will require more frequent replacement) or that disintegrating bearings or other component failures in the hydraulic circuit may be imminent or have already occurred. Open the drain plugs on the main pump casings and check and compare drain oil in the pumps. Look for evidence of grit or metallic particles.

Vibration or unusual noise during operation could be an indication of air leaking into the circuit (Refer to the appropriate Troubleshooting section for component or unit for procedures.), or it may be evidence of a defective pump. The gear-type pilot pump could be defective, causing low pilot pressure, or a main pump broken shoe or piston could be responsible.

NOTE: *If equipped, indicated operating pressure, as shown on the multidisplay digital gauge on the Instrument Panel ("F-Pump" and "R-Pump") will be reduced as a result of a mechanical problem inside the pump. However, pressure loss could also be due to cavitation or air leakage, or other faults in the hydraulic system.*

Check the exterior case drain oil in the main pumps. If no metallic particles are found, make sure there is no air in the system. Unbolt and remove the tank return drain line from the top part of the swing motor, both travel motors and each main pump. If there is air in any one of the drain lines, carefully pre-fill the assembly before bolting together the drain line piping connections. Run the system at low rpm.

HYDRAULIC SYSTEM CLEANLINESS AND OIL LEAKS

MAINTENANCE PRECAUTIONS FOR HYDRAULIC SYSTEM SERVICE

Whenever maintenance, repairs or any other type of troubleshooting or service is being performed, it's important to remember that the hydraulic system - including both the interior and exterior surfaces of assemblies, and every drop of operating fluid - must be protected from contamination.

Dust and other foreign contaminants are major contributors to premature wear in hydraulic circuits. The narrow tolerances, rapidly moving parts and high operating pressures of the system require that fluid be kept as clean as possible. The performance and dependability of the machine (and the service life of individual components) can be noticeably reduced if proper precautions are not observed:

- Use a safe, noncombustible, evaporative-type, low-residue solvent and thoroughly clean exterior surfaces of assemblies before any part of the circuit is opened up or disassembled.

NOTE: *It's just as important to clean the cap and reservoir top before routine fluid changes or quick checks as it is before major repairs. (Accumulated dirt attracts moisture, oil and other fluids - and more dirt.)*

- Keep dismantled parts covered during disassembly. Use clean caps, plugs or tape to protect the disconnected openings of flanges, manifolds and piping.
- Do not allow cleaning solvents or other fluids to mix with the oil in the system. Use clean oil to flush any traces of solvent or other residue before reassembly.
- If metal or rubber fragments are found in the system, flush and replace all fluid in the system and troubleshoot the circuit to identify the source of contamination.

IMPORTANT

Make sure that cleaning solvents will be compatible with rubber materials used in the hydraulic system. Many petroleum based compounds can cause swelling, softening, or other deterioration of system sealing elements, such as O-rings, caps and other seals.

OIL LEAKAGE PRECAUTIONS

Oil that is visibly seeping from joints or seals should always serve as a "red flag" alarm.

Leaks must alert the machine operator and maintenance crew that air, water and dirt have an open, free passageway through which to enter the circuit. Harsh, corrosive salt air, freezing and thawing condensation cycles and working environments that are full of fine dust are especially hazardous. Clogging of valve spools or external piping (especially pilot circuit piping) can gradually diminish or very suddenly put a complete stop to normal hydraulic function. You can prevent having to make these types of repairs by following recommended assembly procedures:

1. Use new O-rings and oil seals whenever hydraulic assemblies are rebuilt.
2. Prepare joint surfaces before assembly by checking alignment and flatness. Clean and repair corrosion or any other damage.
3. Follow bolt torque recommendations and all other assembly requirements

NOTE: Grease lip seals before assembly.

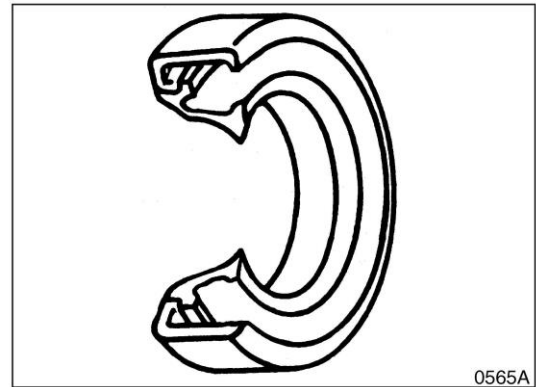

Figure 1

CLEANING AND INSPECTION

GENERAL GUIDELINES

All parts must be clean to permit an effective inspection. During assembly, it is very important that no dirt or foreign material enters unit being assembled. Even minute particles can cause malfunction of close fitting parts such as thrust bearing, matched parts, etc.

⚠ WARNING!

Care should be exercised to avoid inhalation of vapors, exposure to skin and creating fire hazards when using solvent type cleaners.

1. Clean all metal parts thoroughly using a suitable cleaning fluid. It is recommended that parts be immersed in cleaning fluid and moved up and down slowly until all oils, lubricants, and/or foreign materials are dissolved and parts are thoroughly clean.
2. For bearings that can be removed, soak them in a suitable cleaning fluid for a minute or two, then remove bearings from cleaning fluid and strike flat against a block of wood to dislodge solidified particles of lubricant. Immerse again in cleaning fluid to flush out particles. Repeat above operation until bearings are thoroughly clean. To dry bearings, use moisture-free compressed air. Be careful to direct air stream across bearing to avoid spinning bearings that are not lubricated. **DO NOT SPIN BEARINGS WHEN DRYING;** bearings may be rotated slowly by hand to facilitate drying process.
3. Carefully inspect all bearing rollers, cages and cups for wear, chipping or nicks to determine condition. Do not replace a bearing cone or cup individually without replacing mating cup or cone at the same time. After inspection, dip bearings in light weight oil and wrap in clean lintless cloth or paper to protect them until installation.

For those bearings that are to be inspected in place; inspect bearings for roughness of rotation, scoring, pitting, cracked or chipped races. If any of these defects are found, replace bearings. Also inspect defective bearing housing and/or shaft for grooved, galled or burred conditions that indicate bearing has been turning in its housing or on its shaft.

4. It is more economical to replace oil seals, O-rings, sealing rings, gaskets and snap rings when unit is disassembled than waiting for premature failures; refer to latest Micro Fiche and/or Parts Book for replacement items. Be extremely careful when installing sealing members, to avoid cutting or

scratching. Curling under of any seal lip will seriously impair its efficiency. Apply a thin coat of Loctite #120 to outer diameter, of metal casing, on oil seals to assure an oil tight fit into retainer. Use extreme care not to get Loctite on lips of oil seals. If this happens, that portion of the seal will become brittle and allow leakage.

When replacing lip type seals, make sure spring loaded side is towards oil to be sealed.

5. If available, use magna-flux or similar process for checking for cracks that are not visible to the eye. Examine teeth on all gears carefully for wear, pitting, chipping, nicks, cracks or scores. Replace all gears showing cracks or spots where case hardening has worn through. Small nicks may be removed with suitable hone. Inspect shafts and quills to make certain they have not been sprung, bent, or splines twisted and that shafts are true.

NOTE: *Spline wear is not considered detrimental except where it affects tightness of splined parts.*

Inspect thrust washers for distortion, scores, burs, and wear. Replace thrust washer if defective or worn.

6. Inspect bores and bearing surfaces of cast parts and machined surfaces for scratches, wear, grooves and dirt. Remove any scratches and burrs with crocus cloth. Remove foreign material. Replace any parts that are deeply grooved or scratched which would affect their operation.

BEARING INSPECTION

The conditions of the bearing are vital to the smooth and efficient operation of the machinery. When any component containing bearings is disassembled, always carefully examine the condition of the bearings and all of its components for wear and damage.

Once the bearing is removed, clean all parts thoroughly using a suitable cleaning solution. If the bearing is excessively dirty soak the bearing assembly in a light solution and move the bearing around until all lubricants and or foreign materials are dissolved and the parts are thoroughly clean.

When drying bearings, moisture free compressed air can be used. Be careful not to direct the air in a direction which will force the bearing to dry spin while not being properly lubricated.

After the bearings have been cleaned and dried, carefully inspect all bearing rollers, cages and cups for wear, chipping or nicks. If the bearing cannot be removed and is to be inspected in place, check for roughness of rotation, scoring, pitting, cracked or chipped races. If any of these defects are found replace the whole bearing assembly. NEVER replace the bearing alone without replacing the mating cup or the cone at the same time.

After inspection lightly coat the bearing and related parts with oil and wrap in a clean lintless cloth or paper and protect them from moisture and other foreign materials until installation.

It is also important to inspect the bearing housing and/or shaft for grooved, galled or burred conditions that indicate that the bearing has been turning in its housing or on its shaft.

If available, use magna-flux or similar process for checking for cracks that are not visible to the naked eye.

The following illustrations will aid in identifying and diagnosing some of the bearing related problems.

NOTE: *The illustrations will only show tapered roller bearings, but the principles of identifying, diagnosing and remedying the defects are common to all styles and types of bearings.*

Normal Bearing

Smooth even surfaces with no discoloration or marks.

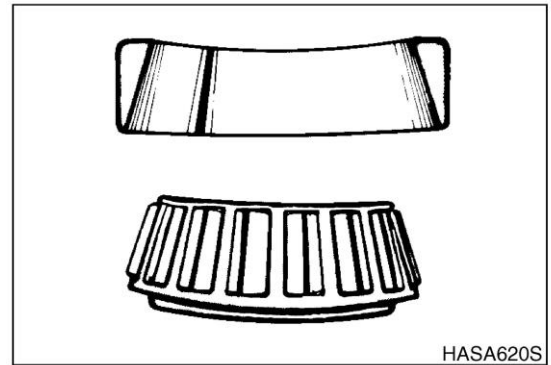

Figure 2

Bent Cage

Cage damage due to improper handling or tool usage.

Replace bearing.

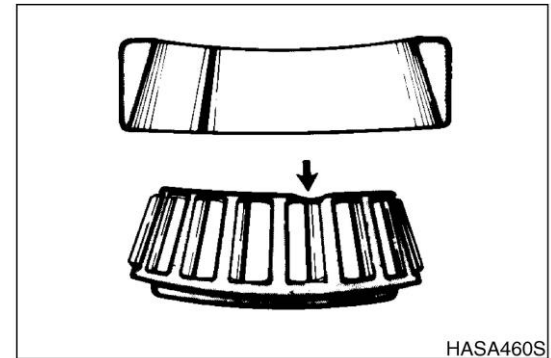

Figure 3

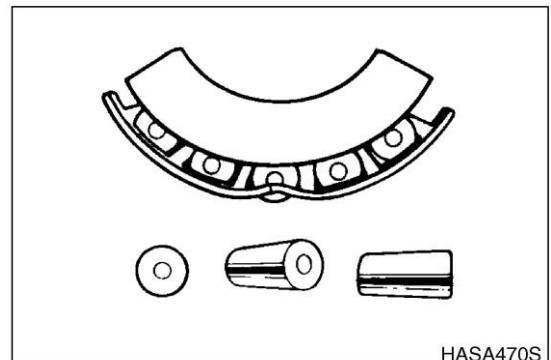

Figure 4

Galling

Metal smears on roller ends due to over heat, lubricant failure or overload.

Replace bearing - check seals and check for proper lubrication.

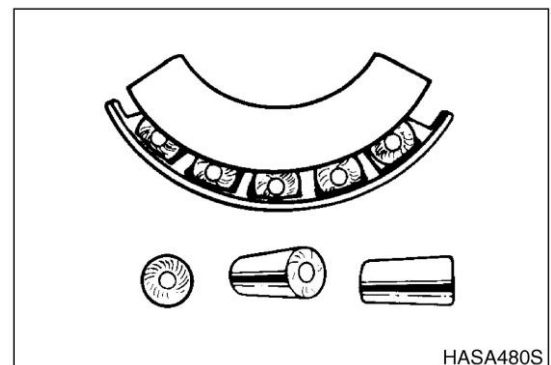

Figure 5

Abrasive Step Wear

Pattern on roller ends caused by fine abrasives.

Clean all parts and housings, check all parts and housings, check seals and bearings and replace if leaking, rough or noisy.

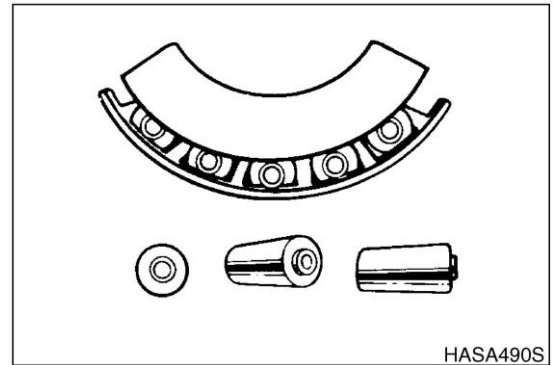

Figure 6

Etching

Bearing surfaces appear gray or grayish black in color with related etching away of material usually at roller spacing.

Replace bearings - check seals and check for proper lubrication.

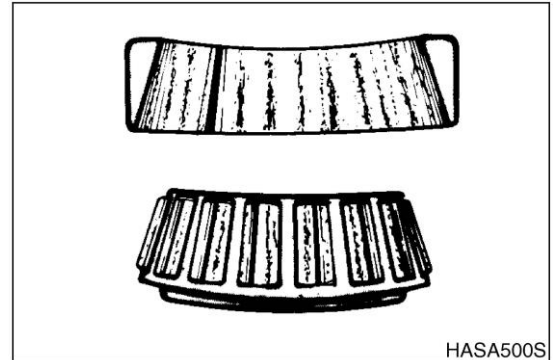

Figure 7

Misalignment

Outer race misalignment due to foreign object.

Clean related parts and replace bearing. Make sure races are properly seated.

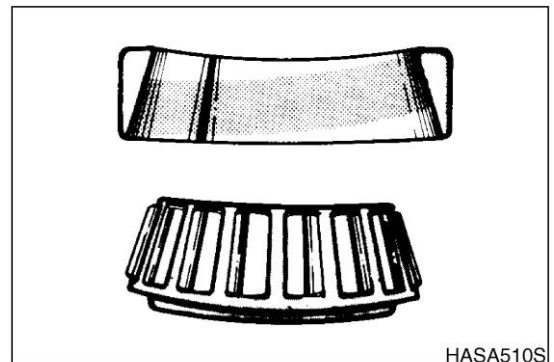

Figure 8

Indentations

Surface depressions on race and rollers caused by hard particles of foreign materials.

Clean all parts and housings, check seals and replace bearings if rough or noisy.

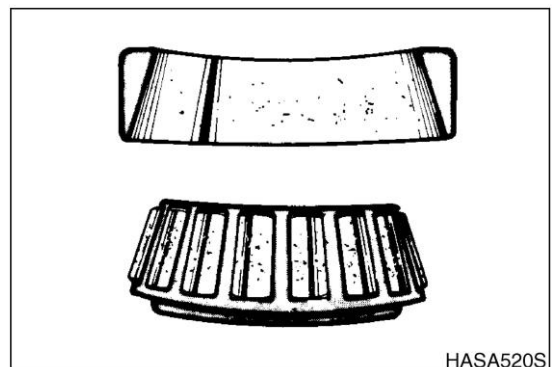

Figure 9

Fatigue Spalling

Flaking of surface metal resulting from fatigue.

Replace bearing - clean all related parts.

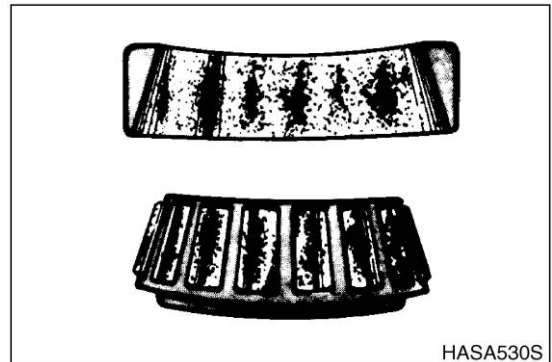

Figure 10

Brinelling

Surface indentations in raceway caused by rollers either under impact loading or vibration while the bearing is not rotating.

Replace bearing if rough or noisy.

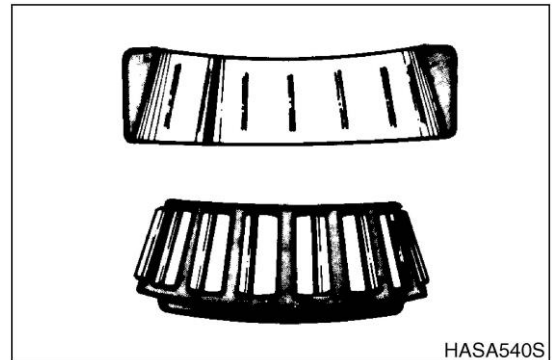

Figure 11

Cage Wear

Wear around outside diameter of cage and roller pockets caused by abrasive material and inefficient lubrication.

Replace bearings - check seals.

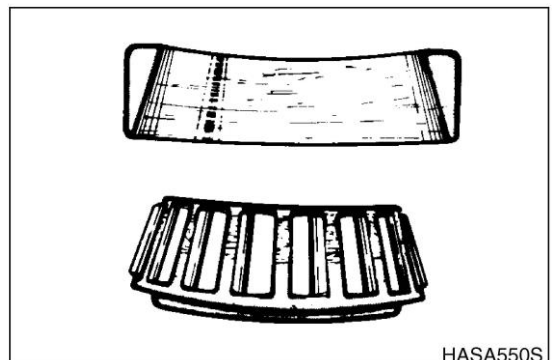

Figure 12

Abrasive Roller Wear

Pattern on races and rollers caused by fine abrasives.

Clean all parts and housings, check seals and bearings and replace if leaking, rough or noisy.

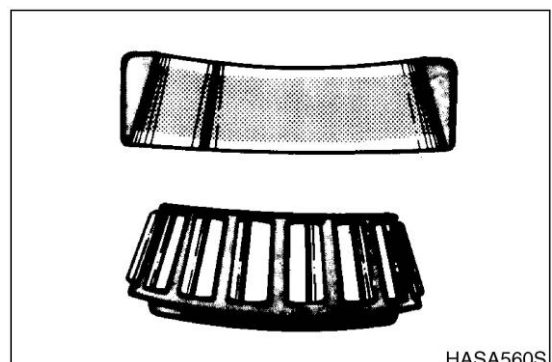

Figure 13

Cracked Inner Race

Race cracked due to improper fit, cocking or poor bearing seat.

Replace all parts and housings, check seals and bearings and replace if leaking.

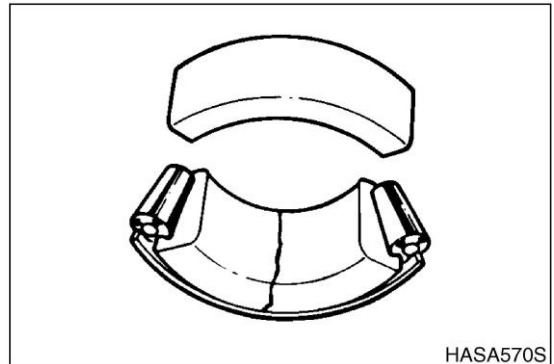

Figure 14

Smears

Smearing of metal due to slippage caused by poor fitting, lubrication, overheating, overloads or handling damage.

Replace bearings, clean related parts and check for proper fit and lubrication.

Replace shaft if damaged.

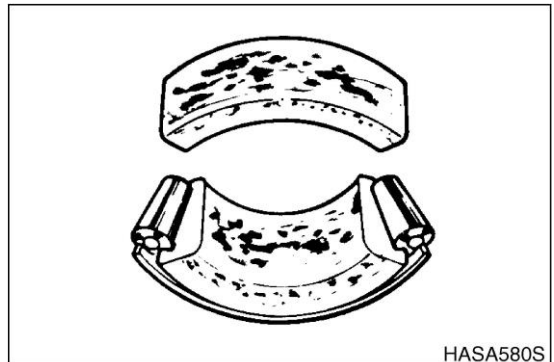

Figure 15

Frottage

Corrosion set up by small relative movement of parts with no lubrication.

Replace bearing. Clean all related parts. Check seals and check for proper lubrication.

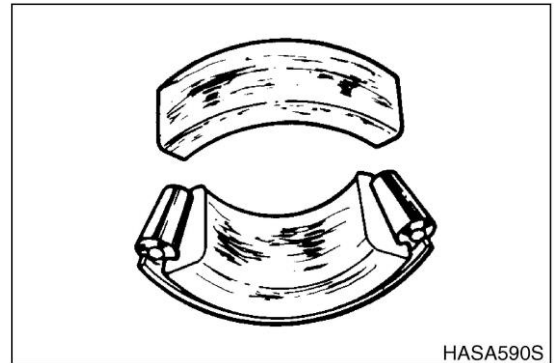

Figure 16

Heat Discoloration

Heat discoloration can range from faint yellow to dark blue resulting from overload or incorrect lubrication.

Excessive heat can cause softening of races or rollers.

To check for loss of temper on races or rollers, a simple file test may be made. A file drawn over a tempered part will grab and cut metal, whereas a file drawn over a hard part will glide readily with no metal cutting.

Replace bearing if over heating damage is indicated.
Check seals and other related parts for damage.

Stain Discoloration

Discoloration can range from light brown to black caused by incorrect lubrication or moisture.

if the stain can be removed by light polishing or if no evidence of overheating is visible, the bearing can be reused.

Check seals and other related parts for damage.

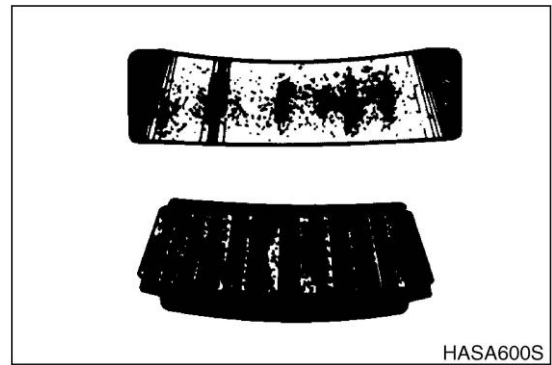

Figure 17

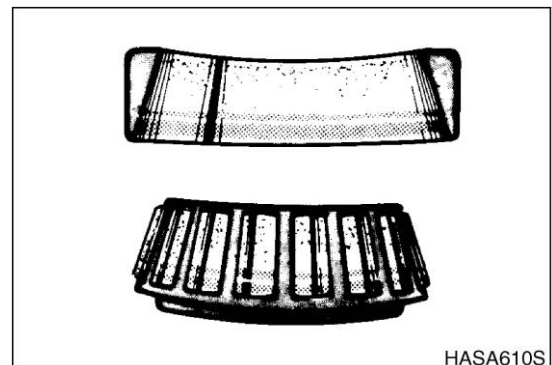

Figure 18

STANDARD TORQUES

 **CAUTION!**

Follow all safety recommendations and safe shop practices outlined in the front of this manual or those contained within this section.

Always use tools and equipment that is in good working order.

Use lifting and hoisting equipment capable of safely handling load.

Remember, that ultimately safety is your own personal responsibility.

TABLE OF CONTENTS



Torque Values for Standard Metric Fasteners	3
Torque Values for Standard U.S. Fasteners	4
Type 8 Phosphate Coated Hardware	6
Torque Values for Hose Clamps.....	7
Torque Values for Split Flanges.....	8
Torque Wrench Extension Tools.....	9
Torque Multiplication	9
Other Uses for Torque Wrench Extension Tools	10
Tightening Torque Specifications (Metric)	10

TORQUE VALUES FOR STANDARD METRIC FASTENERS

NOTE: The units for the torque values are kg•m (ft lb).

Dia. x Pitch (mm)	Grade										
	3.6 (4A)	4.6 (4D)	4.8 (4S)	5.6 (5D)	5.8 (5S)	6.6 (6D)	6.8 (6S)	6.9 (6G)	8.8 (8G)	10.9 (10K)	12.9 (12K)
M5 x Std.	0.15 (1.08)	0.16 (1.15)	0.25 (1.80)	0.22 (1.59)	0.31 (2.24)	0.28 (2.02)	0.43 (3.11)	0.48 (3.47)	0.50 (3.61)	0.75 (5.42)	0.90 (6.50)
M6 x Std.	0.28 (2.02)	0.30 (2.16)	0.55 (3.25)	0.40 (2.89)	0.55 (3.97)	0.47 (3.39)	0.77 (5.56)	0.85 (6.14)	0.90 (6.50)	1.25 (9.04)	1.50 (10.84)
M7 x Std.	0.43 (3.11)	0.46 (3.32)	0.70 (5.06)	0.63 (4.55)	0.83 (6.00)	0.78 (5.64)	1.20 (8.67)	1.30 (9.40)	1.40 (10.12)	1.95 (14.10)	2.35 (1.99)
M8 x Std.	0.70 (5.06)	0.75 (5.42)	1.10 (7.95)	1.00 (7.23)	1.40 (10.12)	1.25 (9.04)	1.90 (13.74)	2.10 (15.18)	2.20 (15.91)	3.10 (22.42)	3.80 (27.48)
M8 x 1	0.73 (5.28)	0.80 (5.78)	1.20 (8.67)	1.00 (7.23)	1.50 (10.84)	1.35 (9.76)	2.10 (15.18)	2.30 (16.63)	2.40 (17.35)	3.35 (24.23)	4.10 (29.65)
M10 x Std.	1.35 (9.76)	1.40 (10.12)	2.20 (15.91)	1.90 (13.74)	2.70 (19.52)	2.35 (19.99)	3.70 (26.76)	4.20 (30.37)	4.40 (31.18)	6.20 (44.84)	7.20 (52.07)
M10 x 1	1.50 (10.84)	1.60 (11.57)	2.50 (18.08)	2.10 (15.18)	3.10 (22.42)	2.80 (20.25)	4.30 (31.10)	4.90 (35.44)	5.00 (36.16)	7.00 (50.63)	8.40 (60.75)
M12 x Std.	2.40 (17.35)	2.50 (18.08)	3.70 (26.76)	3.30 (23.86)	4.70 (33.99)	4.20 (30.37)	6.30 (45.56)	7.20 (52.07)	7.50 (54.24)	10.50 (75.94)	12.50 (90.41)
M12 x 1.5	2.55 (18.44)	2.70 (19.52)	4.00 (28.93)	3.50 (25.31)	5.00 (36.16)	4.50 (32.54)	6.80 (49.18)	7.70 (55.69)	8.00 (57.86)	11.20 (81.00)	13.40 (96.92)
M14 x Std.	3.70 (26.76)	3.90 (28.20)	6.00 (43.23)	5.20 (37.61)	7.50 (54.24)	7.00 (50.63)	10.00 (72.33)	11.50 (83.17)	12.00 (86.79)	17.00 (122.96)	20.00 (144.66)
M14 x 1.5	4.10 (29.65)	4.30 (31.10)	6.60 (47.73)	5.70 (41.22)	8.30 (60.03)	7.50 (54.24)	11.10 (80.28)	12.50 (90.41)	13.00 (94.02)	18.50 (11.26)	22.00 (158.12)
M16 x Std.	5.60 (40.50)	6.00 (43.39)	9.00 (65.09)	8.00 (57.86)	11.50 (83.17)	10.50 (75.94)	15.50 (112.11)	17.90 (129.47)	18.50 (133.81)	26.00 (188.05)	31.00 (224.22)
M16 x 1.5	6.20 (44.84)	6.50 (47.01)	9.70 (70.16)	8.60 (62.20)	12.50 (90.41)	11.30 (81.73)	17.00 (122.96)	19.50 (141.04)	20.00 (144.66)	28.00 (202.52)	35.50 (256.77)
M18 x Std.	7.80 (56.41)	8.30 (60.03)	12.50 (90.41)	11.00 (79.56)	16.00 (115.72)	14.50 (104.87)	21.00 (151.89)	27.50 (198.90)	28.50 (206.14)	41.00 (296.55)	43.00 (311.01)
M18 x 1.5	9.10 (65.82)	9.50 (68.71)	14.40 (104.15)	12.50 (90.41)	18.50 (133.81)	16.70 (120.79)	24.50 (177.20)	27.50 (198.90)	28.50 (206.14)	41.00 (296.55)	49.00 (354.41)
M20 x Std.	11.50 (83.17)	12.00 (86.79)	20.50 (148.27)	18.00 (130.19)	25.00 (180.82)	22.50 (162.74)	35.00 (253.15)	39.50 (285.70)	41.00 (296.55)	58.00 (419.51)	68.00 (491.84)
M20 x 1.5	12.80 (92.58)	13.50 (97.64)	20.50 (148.27)	18.00 (130.19)	25.00 (180.82)	22.50 (162.74)	35.00 (253.15)	39.50 (285.70)	41.00 (296.55)	58.00 (419.51)	68.00 (491.84)
M22 x Std.	15.50 (112.11)	16.00 (115.72)	24.50 (177.20)	21.00 (151.89)	30.00 (216.99)	26.00 (188.05)	42.00 (303.78)	46.00 (332.71)	49.00 (354.41)	67.00 (484.61)	75.00 (542.47)
M22 x 1.5	17.00 (122.96)	18.50 (133.81)	28.00 (202.52)	24.00 (173.59)	34.00 (245.92)	29.00 (209.75)	47.00 (339.95)	52.00 (44.76)	56.00 (405.04)	75.00 (542.47)	85.00 (614.80)
M24 x Std.	20.50 (148.27)	21.50 (155.50)	33.00 (238.68)	27.00 (195.29)	40.00 (289.32)	34.00 (245.92)	55.00 (397.81)	58.00 (419.51)	63.00 (455.67)	82.00 (593.10)	92.00 (655.43)
M24 x 1.5	23.00 (166.35)	35.00 (253.15)	37.00 (267.62)	31.00 (224.22)	45.00 (325.48)	38.00 (202.52)	61.00 (441.21)	67.00 (484.61)	74.00 (535.24)	93.00 (672.66)	103.00 (744.99)

TORQUE VALUES FOR STANDARD U.S. FASTENERS

TYPE	S.A.E. GRADE	DESCRIPTION	BOLT HEAD MARKING
1	1 OR 2	WILL HAVE NO MARKINGS IN THE CENTER OF THE HEAD. Low or Medium Carbon Steel Not Heat Treated.	
5	5	WILL HAVE THREE RADIAL LINES. Quenched and Tempered Medium Carbon Steel.	
8	8	WILL HAVE 6 RADIAL LINES. Quenched and Tempered Special Carbon or Alloy Steel.	

Recommended torque, in foot pounds, for all Standard Application Nuts and Bolts, provided:

1. All thread surfaces are clean and lubricated with SAE-30 engine oil. (See Note.)
2. Joints are rigid, that is, no gaskets or compressible materials are used.
3. When reusing nuts or bolts, use minimum torque values.

NOTE: *Multiply the standard torque by:*

0.65 when finished jam nuts are used.

0.70 when Molykote, white lead or similar mixtures are used as lubricants.

0.75 when parkerized bolts or nuts are used.

0.85 when cadmium plated bolts or nuts and zinc bolts w/waxed zinc nuts are used.

0.90 when hardened surfaces are used under the nut or bolt head.

NOTE: *When reusing bolts and nuts in service, use minimum torque values.*

The following General Torque Values must be used in all cases where **SPECIAL TORQUE VALUES** are not given

NOTE: TORQUE VALUES LISTED THROUGHOUT THIS MANUAL ARE LUBRICATED (WET) THREADS; VALUES SHOULD BE INCREASED 1/3 FOR NONLUBRICATED (DRY) THREADS.				
THREAD SIZE	HEAT TREATED MATERIAL GRADE 5 AND GRADE 8			
	GRADE 5 (3 RADIAL DASHES ON HEAD)		GRADE 8 (6 RADIAL DASHES ON HEAD)	
	FOOT POUNDS (ft lb)	NEWTON METER (N•m)	FOOT POUNDS (ft lb)	NEWTON METER (N•m)
1/4" - 20	6	8	9	12
1/4" - 28	7	9	11	15
5/16" - 18	13	18	18	24
5/16" - 24	15	20	21	28
3/8" - 16	24	33	34	46
3/8" - 24	27	37	38	52
7/16" - 14	38	52	54	73
7/16" - 20	42	57	60	81
1/2" - 13	58	79	82	111
1/2" - 20	65	88	90	122
9/16" - 12	84	114	120	163
9/16" - 18	93	126	132	179
5/8" - 11	115	156	165	224
5/8" - 18	130	176	185	251
3/4" - 10	205	278	290	393
3/4" - 16	240	312	320	434
7/8" - 9	305	414	455	617
7/8" - 14	334	454	515	698
1" - 8	455	617	695	942
1" - 14	510	691	785	1064
1 1/8" - 7	610	827	990	1342
1 1/8" - 12	685	929	1110	1505
1 1/4" - 7	860	1166	1400	1898
1 1/4" - 12	955	1295	1550	2102
1 3/8" - 6	1130	1532	1830	2481
1 3/8" - 12	1290	1749	2085	2827
1 1/2" - 6	1400	2034	2430	3295
1 1/2" - 12	1690	2291	2730	3701
1 3/4" - 5	2370	3213	3810	5166
2" - 4 1/2	3550	4813	5760	7810

NOTE: If any bolts and nuts are found loose or at values less than what the chart states, it is recommended that the loose bolt and/or nut be replaced with a new one.

TYPE 8 PHOSPHATE COATED HARDWARE

This chart provides tightening torque for general purpose applications using original equipment standard hardware as listed in the Parts Manual for the machine involved. **DO NOT SUBSTITUTE.** In most cases, original equipment standard hardware is defined as Type 8, coarse thread bolts and nuts and thru hardened flat washers (Rockwell "C" 38 - 45), all phosphate coated and assembled without supplemental lubrication (as received) condition.

The torques shown below also apply to the following:

1. Phosphate coated bolts used in tapped holes in steel or gray iron.
2. Phosphate coated bolts used with phosphate coated prevailing torque nuts (nuts with distorted threads or plastic inserts).
3. Phosphate coated bolts used with copper plated weld nuts.

Markings on bolt heads or nuts indicate material grade ONLY and are NOT to be used to determine required torque.

NOMINAL THREAD DIAMETER	STANDARD TORQUE ±10%	
	KILOGRAM METER (kg•m)	FOOT POUNDS (ft lb)
1/4"	1.1	8
5/16"	2.2	16
3/8"	3.9	28
7/16"	6.2	45
1/2"	9.7	70
9/16"	13.8	100
5/8"	19.4	140
3/4"	33.2	240
7/8"	53.9	390
1"	80.2	580
1 - 1/8"	113.4	820
1 - 1/4"	160.4	1160
1 - 3/8"	210.2	1520
1 - 1/2"	279.4	2020
1 - 3/4"	347.1	2510
2	522.8	3780

TORQUE VALUES FOR HOSE CLAMPS

The following chart provides the tightening torques for hose clamps used in all rubber applications (radiator, air cleaner, operating lever boots, hydraulic system, etc.).

CLAMP TYPE AND SIZE	TORQUE			
	RADIATOR, AIR CLEANER, BOOTS, ETC.		HYDRAULIC SYSTEM	
	KILOGRAM METER (kg•m)	INCH POUNDS (in lb)	KILOGRAM METER (kg•m)	INCH POUNDS (in lb)
"T" Bolt (Any Diameter)	0.68 - 0.72	59 - 63	-----	-----
Worm Drive - Under 44 mm (1-3/4 in) Open Diameter	0.2 - 0.3	20 - 30	0.5 - 0.6	40 - 50
Worm Drive - Over 44 mm (1-3/4 in) Open Diameter	0.5 - 0.6	40 - 50	-----	-----
Worm Drive - All "Ultra- Tite"	0.6 - 0.7	50 - 60	0.5 - 0.6	40 - 50

TORQUE VALUES FOR SPLIT FLANGES

The following chart provides the tightening torques for split flange connections used in hydraulic systems. Split flanges and fitting shoulders should fit squarely. Install all bolts, finger tight and then torque evenly.

NOTE: Over torquing bolts will damage the flanges and/or bolts, which may cause leakage.

FLANGE SIZE (*)	BOLT SIZE	BOLT TORQUE	
		KILOGRAM METER (kg•m)	INCH POUNDS (in lb)
1/2"	5/16"	2.1 - 2.5	15 - 18
3/4"	3/8"	3.0 - 3.7	22 - 27
1"	3/8"	3.7 - 4.8	27 - 35
1 - 1/4"	7/16"	4.8 - 6.2	35 - 45
1 - 1/2"	1/2"	6.4 - 8.0	46 - 58
2"	1/2"	7.6 - 9.0	55 - 65
2 - 1/2"	1/2"	10.9 - 12.6	79 - 91
3"	5/8"	19.1 - 20.7	138 - 150
3 - 1/2"	5/8"	16.2 - 18.4	117 - 133

(*) - Inside diameter of flange on end of hydraulic tube or hose fitting.

NOTE: Values stated in chart are for Standard Pressure Series (Code 61) Split Flanges.

TORQUE WRENCH EXTENSION TOOLS

Very large diameter, high grade fasteners (nuts, bolts, cap screws, etc.) require a great deal of turning force to achieve recommended tightening torque values.

Common problems that could occur as a result are:

- Recommended torque exceeds the measuring capacity of the torque wrench.
- Specialized sockets do not fit the adapter on the front end (nose) of the torque wrench.
- Generating adequate force on the back end (handle) of the wrench is difficult or impossible.
- Restricted access or an obstruction may make use of the torque wrench impossible.
- A unique application requires fabrication of an adapter or other special extension.

Most standard torque wrenches can be adapted to suit any one of the proceeding needs or situations, if the right extension tool is used or fabricated.

TORQUE MULTIPLICATION

A wrench extension tool can be used to increase the tightening force on a high capacity nut or bolt.

For example, doubling the distance between the bolt and the back (handle) end of the torque wrench doubles the tightening force on the bolt.

It also halves the indicated reading on the scale or dial of the torque wrench. To accurately adjust or convert indicated scale or dial readings, use the following formula:

$I = A \times T / A + B$ where:

I = Indicated force shown on the torque wrench scale or dial.

T = Tightening force applied to the nut or bolt (actual Torque).

A = Length of the torque wrench (between the center of the nut or bolt and the center of the handle).

B = Length of the extension.

As an example, if a 12" extension is added to a 12" torque wrench, and the indicated torque on the dial reads "150 ft lb," the real force applied to the bolt is 300 ft lb:

$$I = \frac{A \times T}{A + B} = \frac{12 \times 300}{12 + 12} = \frac{3600}{24} = 150$$

NOTE: The formula assumes that there is no added deflection or "give" in the joint between the extension and torque wrench. Readings may also be inaccurate:

- If the extension itself absorbs some of the tightening force and starts to bend or bow out.
- If an extension has to be fabricated that is not perfectly straight (for example, an extension made to go around an obstruction, to allow access to a difficult to tighten fastener), the materials and methods used must be solid enough to transmit full tightening torque.

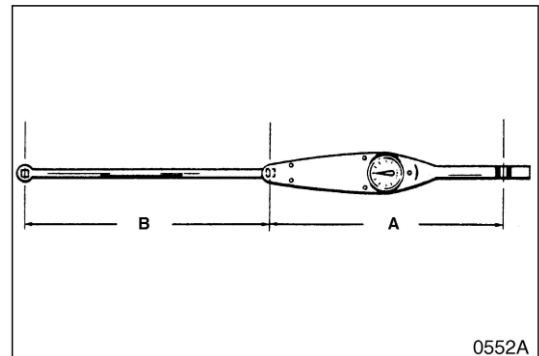

Figure 1

OTHER USES FOR TORQUE WRENCH EXTENSION TOOLS

Torque wrench extensions are sometimes made up for reasons other than increasing leverage on a fastener. For example, a torque wrench and extension can be used to measure adjustment "tightness" of a linkage or assembly. Specially fabricated extensions can be used to make very precise checks of the force required to engage or disengage a clutch mechanism, release a spring-applied brake assembly, or "take up" free play in most any movable linkage.

Once the value of the adjustment force is established, repeated checks at regular intervals can help to monitor and maintain peak operating efficiency. These types of adjustment checks are especially useful if physical measurements of linkage travel are difficult to make or will not provide the needed degree of precision and accuracy.

To allow the assembly or mechanism to accept a torque wrench, welding a nut or other adapter on the end of a linkage shaft or other leverage point will allow turning the shaft or assembly manually.

TIGHTENING TORQUE SPECIFICATIONS (METRIC)

(For coated threads, prelubricated assemblies.)

 CAUTION!
Disassembly, overhaul and replacement of components on the machine, installation of new or replacement parts and/or other service-related maintenance may require the use of thread or flange sealing assembly compound.
Use the information on this page as a general guide in selecting specific formulas that will meet the particular requirements of individual assembly installations. HCE does not specifically endorse a specific manufacturer or brand name but the following table of "Loctite" applications is included for which cross-references to other makers' products should also be widely available.

IMPORTANT
Use primer "T" or "N" for all cold weather assembly of fastener adhesives, with Thread locker sealers 222, 242/243, 262, 271, 272, or 277.

I. "Loctite" Fastener Adhesives

Product	Application	Color	Removal	Break-away Cure Strength (in lb) of Sealer Alone
222	Low strength for 6 mm (1/4") or smaller fasteners.	Purple	Hand tools	45
242 or 243	Medium strength for 6 mm (1/4") and larger fasteners.	Blue	Hand tools	80
262	High strength for high grade fasteners subject to shock, stress and vibration.	Red	Heat/260°C (500°F) Remove HOT (NO solvent)	160
271	Extra high strength for fine thread fasteners up to 25 mm (1") diameter.	Red	Heat/260°C (500°F) Remove HOT	160
272	High temperature/high strength for hostile environments to 232°C (450°F).	Red	Heat/316°C (600°F) Remove HOT	180
277	Extra high strength for coarse thread fasteners 25 mm (1") diameter and larger.	Red	Heat/260°C (500°F) Remove HOT	210

II. "Loctite" Pipe Thread Sealant

Product	Application	Color	Removal	Required Setup
545	"No-filler/non-clog" formula for high-pressure hydraulic systems. Over-application will not restrict or foul system components.	Purple	Hand tools	4 Hours (or 1/2 hour with Locquic "T" Primer)
656	Solvent-resistant, higher viscosity tapered thread sealer.	White	Hand tools	4 Hours (or 1/2 hour with Locquic "T" Primer)

III. "Loctite" gasket/flange sealer

Product	Application	Color	Notes
518	Gasket eliminator specifically made for aluminum flanges/surfaces. For hydraulic systems to 34,475 kPa (5,000 psi).	Red	Use Locquic "N" primer for fast (1/2 - 4 hours) setup. Unprimed setup 4 - 24 hours.
504	Low pressure/wide-gap gasket eliminator compound. Fills gaps to 0.0012 mm (0.030"), cures to rigid seal.	Orange	Use Locquic "N" primer for faster (1/2 - 4 hours) setup. Unprimed setup 4 - 24 hours.
515	General purpose, fast setup, flexible-cure gasket eliminator. For nonrigid assemblies subject to shock, vibration or deflection.	Purple	Use Locquic "N" primer for faster (1/4 - 2 hours) setup. Unprimed setup 1 - 12 hours.

IV. "Loctite" retaining compounds

Product	Application	Color	Notes
609	For bushings, sleeves, press-fit bearings, splines and collars. For gaps to 0.0002 mm (0.005"), temperatures to 121°C (250°F).	Green	Use Locquic "N" primer for increased bond strength and all cold temperature applications.
620	For high temperatures to 232°C (450°F).	Green	Same as 609, above.
680	For high strength bonds and tight clearance gaps, to 0.00008 mm (0.002").	Green	Same as 609, above.

V. "Loctite" Adhesives

Product	Application	Color	Notes
380	Black Max instant adhesive for shock and vibration-resistant bonds.	Black	May take 120 hours to reach full cure strength.
454	Adhesive for porous surfaces.	Clear	Full strength in 24 hours.
480	Increased strength (+50%), shock and vibration-resistant.	Black	Full strength in 24 hours.

UPPER STRUCTURE

COUNTERWEIGHT

 **CAUTION!**

Follow all safety recommendations and safe shop practices outlined in the front of this manual or those contained within this section.

Always use tools and equipment that is in good working order.

Use lifting and hoisting equipment capable of safely handling load.

Remember, that ultimately safety is your own personal responsibility.

TABLE OF CONTENTS

Specifications 3
Counterweight 3

Specifications

NOTE: *Weight*

Weight
1600 kg (3,527 lb)

Counterweight

1. Parts list

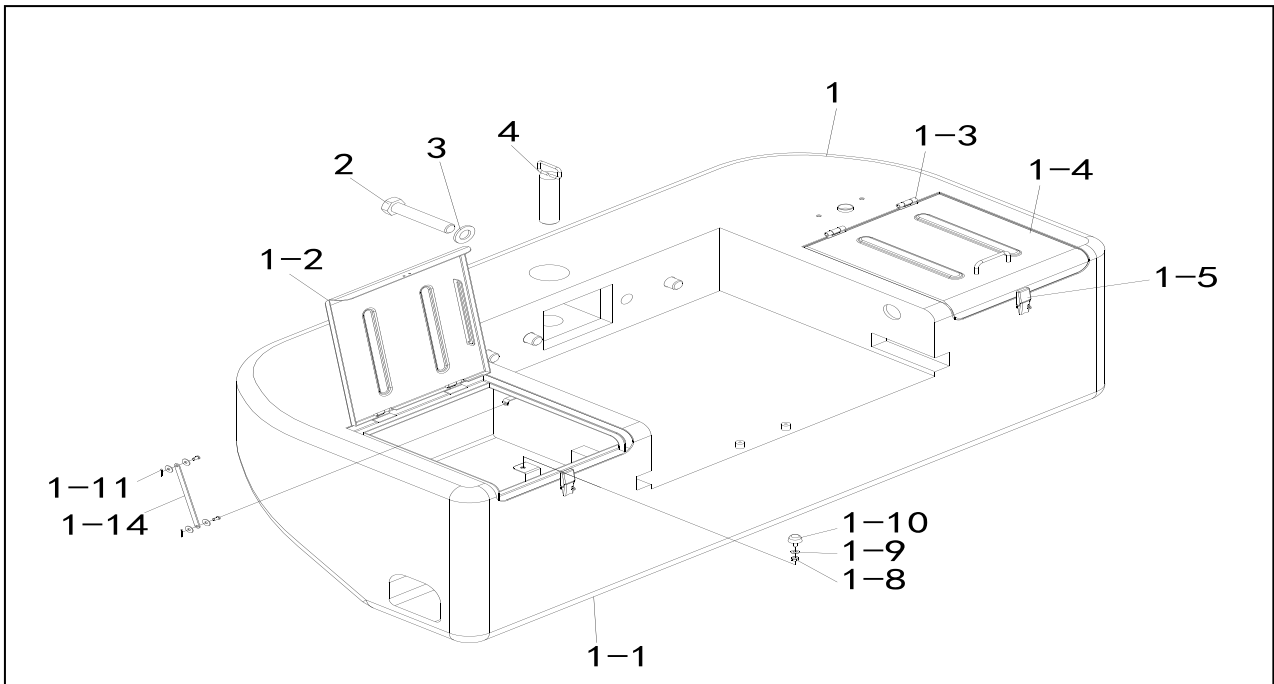

Figure. 1

Reference Number	Description	Reference Number	Description
1	COUNTERWEIGHT ASSAMBLE	1-9	WASHER
1-1	COUNTERWEIGHT	1-10	BUFFER
1-2	BATTERY COVER(L)	1-11	COTTER PIN
1-3	HINGERS	1-14	SUPPORT ROD
1-4	BATTERY COVER(R)	2	BOLT
1-5	RIVET	3	WASHER
1-8	NUT	4	PIN

2. TORQUE

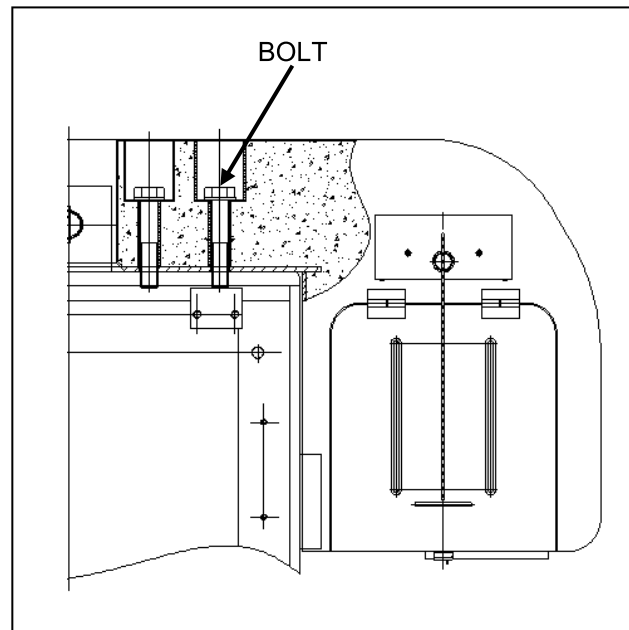

Figure. 2

NOTE: 1) *Tighten bolt to torque value list in the following table.*

100 kg • m (726 ft lb)

HYDRAULIC OIL TANK

 **CAUTION!**

Follow all safety recommendations and safe shop practices outlined in the front of this manual or those contained within this section.

Always use tools and equipment that is in good working order.

Use lifting and hoisting equipment capable of safely handling load.

Remember, that ultimately safety is your own personal responsibility.

TABLE OF CONTENTS

General Description..... 3
Parts List..... 3
Specifications..... 4

GENERAL DESCRIPTION

PARTS LIST

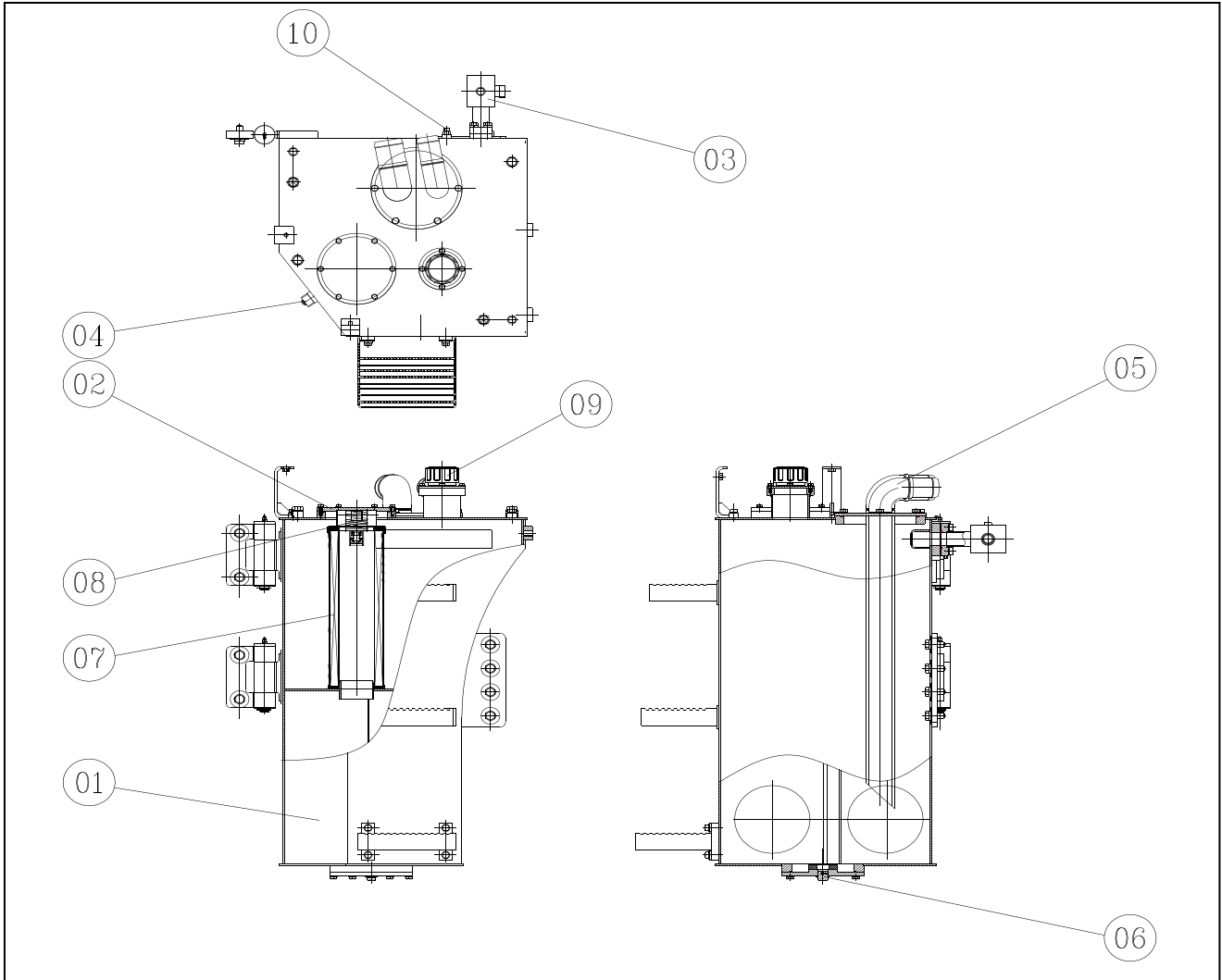

Figure 1

Reference Number	Description	Reference Number	Description
01	Oil Tank	06	Drain Plug
02	Cover	07	Return Filter
03	Return Pipe	08	Spring
04	Level Gauge	09	Air Breather
05	Suction Pipe	10	Adapter

SPECIFICATIONS

TYPE	Pressure seal
Capability (sys)	260 L
Breather	
Starting pressure	0.035 MPa
Return filter	
Filter precision	12 μ
Pressure descending	0.045 MPa @1200L/min

LOWER STRUCTURE AND CHASSIS

CENTER JOINT (ARTICULATION JOINT)

CAUTION!

Follow all safety recommendations and safe shop practices outlined in the front of this manual or those contained within this section.

Always use tools and equipment that is in good working order.

Use lifting and hoisting equipment capable of safely handling load.

Remember, that ultimately safety is your own personal responsibility.

TABLE OF CONTENTS

General Description	3
Maintenance Standard	4

General Description

The loader frame is an articulated type: the front frame is joined to the rear frame with two hinge pins around which the loader pivots for steering.

⚠ CAUTION!

When the loader is steered, the area near center hinge pins becomes so narrow that you may get caught between front and rear frames. Before trying to service the loader, make sure to set frame lock plate.

Prior to moving (traveling) the loader, make sure the frame lock plate is set to original position.

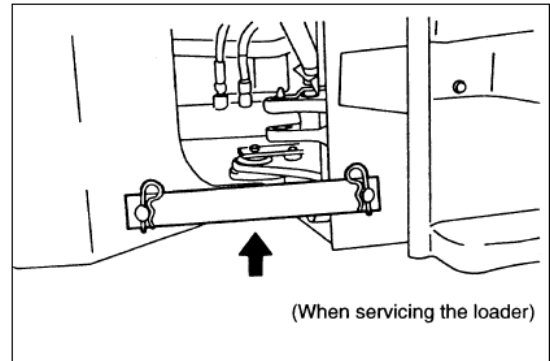

Figure 1

Maintenance Standard

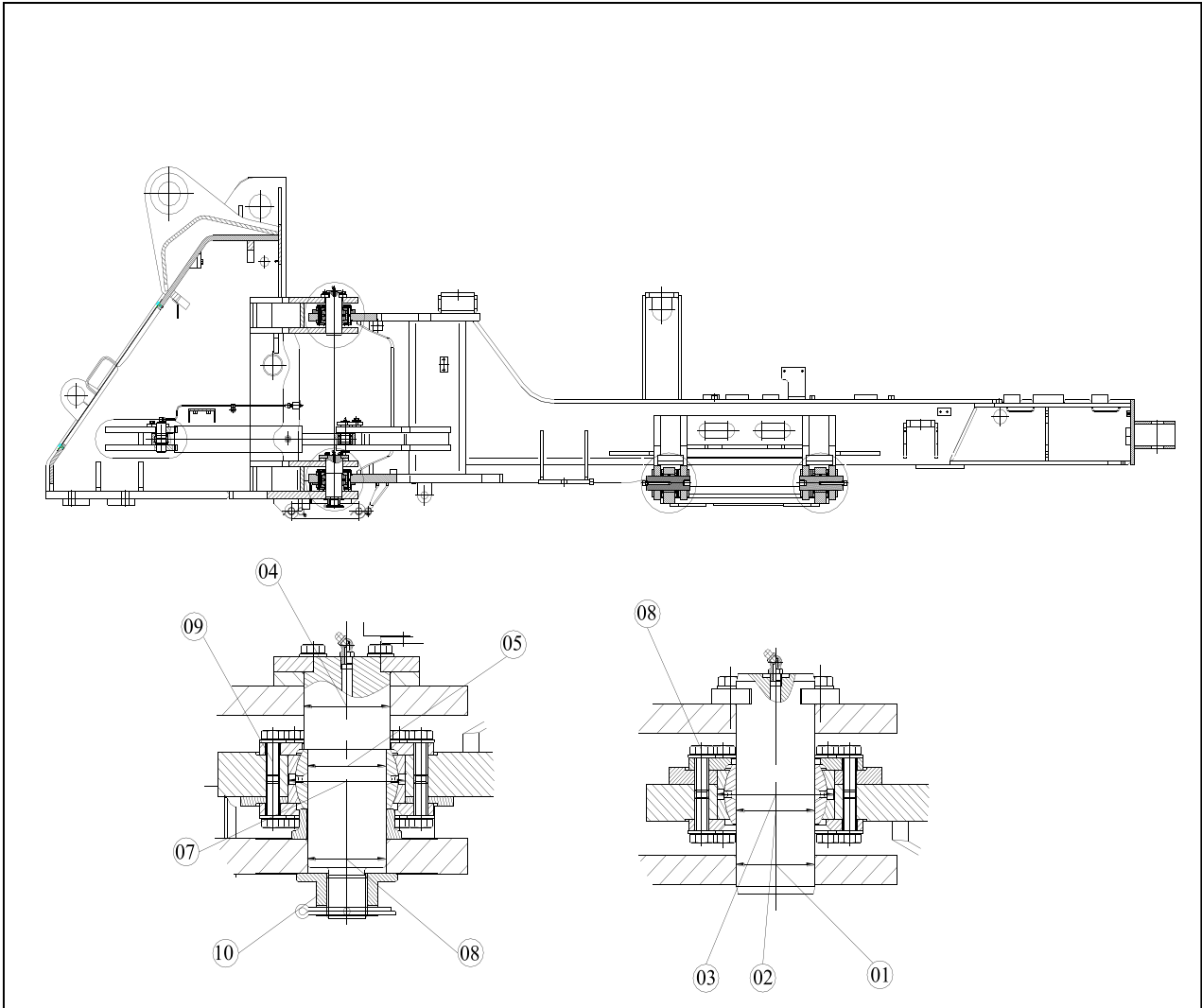

Figure 2

(LOWER HINGE BEARING)

(UPPER HINGE BEARING)

UNIT : mm

No.	Check item	Criteria				Remedy
		Standard size	Tolerance		Standard Clearance	
1	Clearance between upper hinge pin and rear frame		70	0		+0.174
		-0.019		+0.1		
2	Clearance between upper hinge pin and bearing	70	0	0	-0.015-0.019	-
			-0.019	-0.015		
3	Clearance between bearing and front frame	105	0	0	-0.035-0.015	-
			-0.015	-0.035		
4	Clearance between lower hinge pin and front frame	77	0	+0.174	0.1-0.248	-
			-0.074	+0.1		
5	Clearance between lower hinge pin and bearing	70	0	0	-0.015-0.019	-
			-0.019	-0.015		
6	Clearance between lower hinge pin and front frame	70	0	+0.174	0.1-0.193	-
			-0.019	+0.1		
7	Clearance between lower hinge bearing and rear frame	105	0	0	-0.035-0.015	-
			-0.015	-0.035		
08	Tightening torque of upper hinge cap mounting bolt	9±1.0 kg·m				Replace
09	Tightening torque of lower hinge cap mounting bolt	9±1.0 kg·m				
10	Tightening torque of lower hinge slotted nut	110±1.0 kg·m				

ENGINE AND DRIVE TRAIN

5Ton Diesel Engine

 **CAUTION!**

Follow all safety recommendations and safe shop practices outlined in the front of this manual or those contained within this section.

Always use tools and equipment that is in good working order.















Use lifting and hoisting equipment capable of safely handling load.

Remember, that ultimately safety is your own personal responsibility.

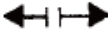
TABLE OF CONTENTS

Description of the Illustration Marks.....	3
Usage Instruction.....	4
Guide for Maintenance.....	7
Maintenance Contents.....	10
Schematic Diagram of Main Systems.....	20
Tightening Torque and Tightening Method of Rigid Bolts.....	24
Fuel, Oil, Coolant and Auxiliary Materials.....	29
Electric System.....	31
Adjustment and Replacement of Main Parts and Components.....	33
Common Troubles and Remedy	54

DESCRIPTION OF THE ILLUSTRATION MARKS

	Dismounting (assembly parts)		Oil coating
	Fitting (assembly parts)		Special tools, such as K --- ---, KUKKO, --- ---, TS --- ---W
	Marking (do before disassemble, adjust when assemble)		Pay attention to assembly direction
	Filling- full charge (such as lubricating oil, cooling water etc.)		Deflating
	Draining off (lubricating oil or cooling water)		Unloosing (such as: unloose clamping equipment)
	(loose-proof-fixed) Coat fluid sealant		Clamping (such as: reinforcing clamp equipment)
	Accident preventing (marks for dangerous occasion)		Inspecting-adjusting (such as: tightening torque, dimension pressure and clearance)
	Replacement when reassembly		Inspecting

USAGE INSTRUCTION

OPERATING NOTICE FOR NEW DIESEL ENGINE

For construction machinery application, the engine should be running under part load(the accelerator should be controlled under 3/4 full load)during its initial 60h running.

The lubricating oil should be replaced after the primary running period, otherwise the engine parts possibly be over worn or damaged. Proper protection and maintenance will—ensure your better performance, more economical and longer service life.

Check the oil pressure gauge, temperature meter alarm indicator light and other instrument every day.

Keep daily maintenance as per this manual .

PACKAGE OPENING OF ENGINE

When opening the packing of engine, you should firstly check the surface of engine and the amount of accessories as per packing list, then proceed on as following :

1. Clean the anticorrosive coating and preservative of outer parts.
2. Drain off the seal diesel oil from fuel filters and fuel supply system(the engine is also allowed to be started before seal diesel oil draining, but not allowed to be operated at full load until the seal diesel oil of fuel supply. System has been used up and the usual fuel has been provided).
3. Turn the flywheel and inject solvent to air intake manifold till the seal oil of cylinder has been drained off.
4. As per the agreement between Weichai and the customer, the engines supplied with empty oil sumps should be filled with oil.
5. As per the agreement between Weichai and the customer, and as per customer's requirement before delivery, coolant performance should be checked if the engine has been filled up with coolant. The coolant could be remained to use if its anti-freezing performance could meet -30°C or -35°C and pH is 7-8(1itmusless), and its total rigidity number is 5-15°d [9-27°f (rigidity)], otherwise it should be drained off and replaced by new coolant containing antifreeze. The volume of coolant filled to engine is approximately 40 liter.

INSPECTION BEFORE STARTING

Inspect the coolant level.

Inspect the fuel level.

Inspect the lubricating oil level.

STARTING

Put the power switch and starting key at the starting position.

Put the gearlever at empty gear-matching position.

Step down footplate of clutch and footplate of accelerator, pull the handle of extra fuel supply device for starting(if have), and starting the engine. The handle of the device should be reset after engine is started. If the engine can't be started, repeat the above operating after about 1 minute. Oil pressure gauge should immediately indicate number values after engine started. The extra fuel supply device for auxiliary starting device should not to be used during starting in thermal state.

Low temperature starting - Maintenance Manual of 5ton Diesel Engine with electric control flame preheating device.

When the temperature of coolant inside the engine is lower than -23°C , turn on the electronic key, the preheating indicator lighting, the heating plug is heated, and the preheating indicator will be automatically flickered after 50S. When the heating plug is heated to $850-950^{\circ}\text{C}$, press down the start button, connect the starter, the electromagnetic valve will be automatically opened, and the heating plug will be provided with fuel to proceed flame preheating, and the engine can be easily started under -25°C .

With low temperature auxiliary starting device

One bottle of starting fuel will be provided with the truck which fitted with low temperature auxiliary starting device. It can't be preserved when the ambient temperature is higher than 50°C . To prevent from fire, it should be put at a cool place in summer.

Starting process : Input starting fuel to the tank under the instrument plate in the driver-cab, pull the hand-pump three times before connecting the starter, after the engine run several rotations continue to pull the hand- pump till the engine started, but don't pull too many times before starting; In the case of very low temperature, continue to pull the hand-pump after starting till the engine runs smoothly. With this auxiliary device, the engine can be started easily under -40°C .

RUNNING OF DIESEL ENGINE

When the engine running at the speed lower than the speed of the biggest torque, it is not allowed to continue running on full load over 1 min.

After running on full load, the engine should run in idling speed for 3-5 minutes before stopped.

Often watch and check the oil pressure gauge and coolant temperature meter.

Stop the engine if the pressure and temperature cannot meet the standard requirement.

NOTE : *Diesel engine can not continue to run when the coolant temperature is lower than 60 °C or higher than 100°C , because this would damage the engine .*

ENGINE'S RUNNING STOP

Put the hand-accelerator of injection pump at zero position, stop the engine, and readjust the hand-accelerator.

NOTE: *The engine should run in idling speed for 1-2 minutes before stopped.*

GUIDE FOR MAINTENANCE OF DIESEL ENGINE

DAILY MAINTENANCE INSPECTION

1. Check the oil level.
2. Check the coolant level.
3. Check the fuel level.
4. Check whether the fan is damaged.
5. Check whether the V-belt is cracked or scratched.
6. Check whether the accessories are fixed well.
7. Check whether the water or oil is leaking.
8. Check whether the charging indicator light is in order.
9. Inspect sufficient grease.
10. Inspect oil pressure and water temperature is normal condition.
11. Inspect that exhaust temperature, sound and vibration are normal condition.
12. Inspect rotary speed is stable.

PERIODIC MAINTENANCE

Regular maintenance can be conduct on as per the following table. If the operating condition is heavy dust content or the engine running on started-stopped frequently, the regular maintenance period should be shortened accordingly.

Maintenance Period:

Period	Running hours(h)
The first inspection	30-50
Periodical inspection	Every 250
Maintenance I(WD1)	Every 500
Maintenance2(WD2)	Every 1000
Maintenance 3(WD3)	Every 2000
Maintenance4(WD4)	Every 4000

NOTE: *The above maintenance period is calculated based on 1,500 running hours per year of the diesel engine. If the running hours of diesel engine per year are less than 500 hours, the maintenance period is 0.5 times of the above maintenance period. If the running hours of diesel engine are more than 1,500 hours, the maintenance period is 1.5 times of the above maintenance period.*

Replacement and Work in Inspection and Maintenance of Engine:

Diesel Engine Maintenance Item	1# Inspection	P	WD1	WD2	WD3	WD4
Replace diesel engine oil (once a year at least)	▲	▲	▲	▲	▲	▲
Lubricate water pump (via grease cup)	▲	▲	▲	▲	▲	▲
Replace oil filter	▲	In replacement of engine oil				
Check and adjust valve clearance	▲		▲	▲	▲	▲
Check injector nozzle opening pressure	▲				▲	▲
Replace fuel filter			▲	▲	▲	▲
Clean fuel pump coarse filter			▲	▲	▲	▲
Check coolant quantity and add enough coolant	▲	▲	▲	▲	▲	▲
Replace coolant		Every 24 months				
Fasten cooling pipe clamp	▲					
Fasten connecting parts of intake pipe, hose and flange	▲		▲	▲	▲	▲
Check air filter maintenance light			▲	▲	▲	▲
Clean dust cup of air filter (excluding automatic dust exhaust type)		▲	▲	▲	▲	▲
Clean air filter main element	When indicator light comes on					
Replace air filter main element				▲		
Replace air filter safety element	After 5 times of main filter element cleaning					
Check and fasten V-belt	▲	▲	▲	▲	▲	▲
Check supercharger bearing clearance						▲
Check fuel injection pump in special maintenance station						▲
Adjust idle speed	▲					

MAINTENANCE RECORD

Engine number _____ Model _____

User _____ Equipment _____

Date	Running Kilometers / hours or interval hours	Actual Kilometers	Maintenance contents	operator	Remark

MAINTENANCE CONTENTS

Daily Maintenance

Preventive maintenance should be done everyday in order to understand the engine's condition.

Before starting the engine should check the oil level coolant level and the fuel level.

Inspect :

- Leakage
- Fast wearing parts
- Any unconventionality

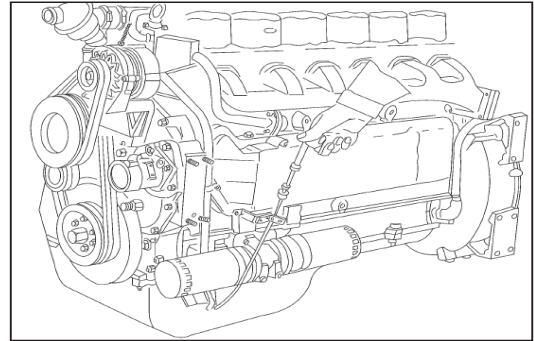

Inspect the oil level height

When the oil level is lower than the lower limit or higher than the upper limit, it is not allowed to start the engine.

After the engine stopped, inspect the oil level at least 5 minutes later in order to ensure the oil can flow back to the oil sump. The oil volume tolerance between the lower limit and the upper limit is 3 liters.

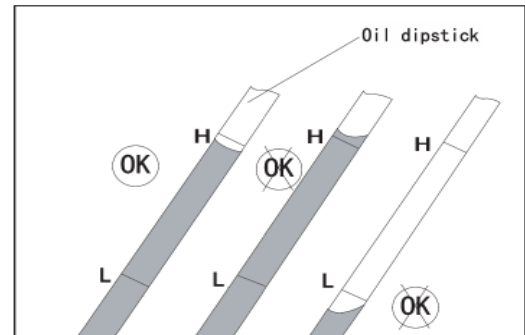

Inspect the coolant level

Inspect the coolant level through the vitreous view hole, if the coolant is not sufficient, open the inlet cover and fill into the coolant.

NOTE: When opening the inlet cover, must press down the exhaust button firstly to prevent hot coolant from injuring people.

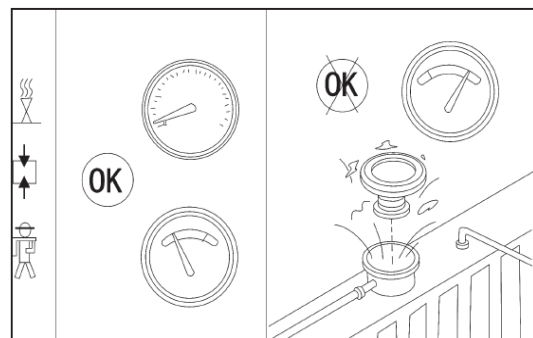

Inspect the fan

Check whether the plastic fan is distorted. For steel fan, check whether the rivet loosened and the vane is curved to ensure reliable running.

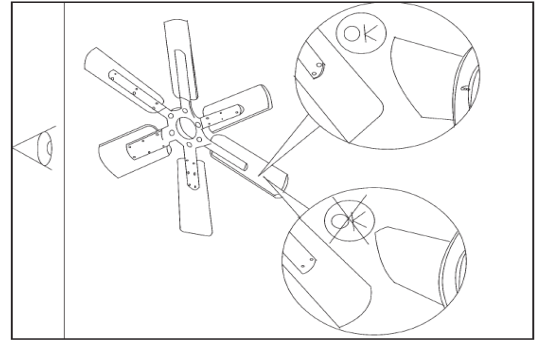

Inspect the V-belts

Inspect the V-belts with your eyes to find if there is any crack or scratch on the V-belts. Replace them if necessary.

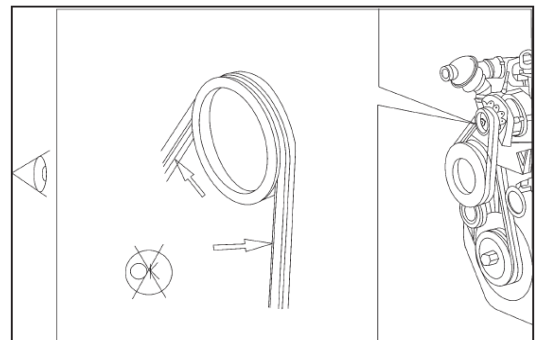

Drain off the water and deposit from the small filter cup fitted on the fuel delivery pump.

Unscrew the bottom bolt of the small filter cup, dismount it and drain off the water and deposit, then re-install the cup again.

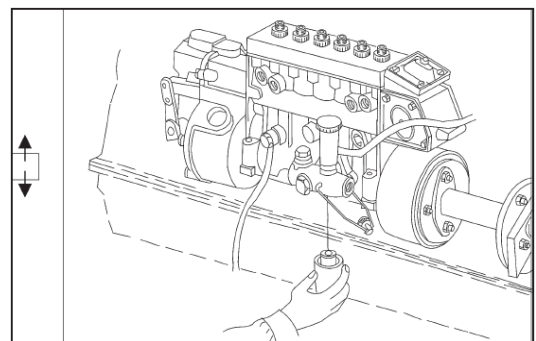

Maintenance Content of Different Levels

The following contents will be added except daily maintenance items:

Replace the oil and oil filter.

The oil will be polluted after using, the pollution contents is of accordance with the consumption of fuel and oil.

NOTE: *The replacement period of oil under proper using condition cannot beyond 250h (10,000Kilometers).*

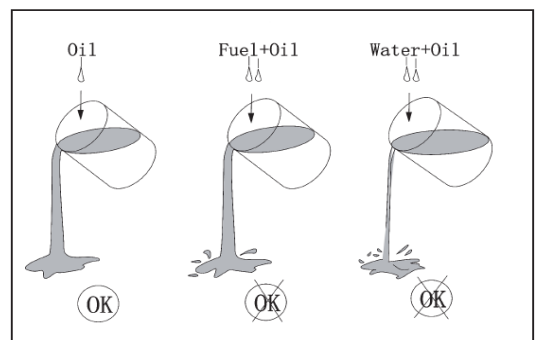

Replace the oil and oil filter to clean the impurities containing in oil.

NOTE: *The oil should be drained off when it is hot.*

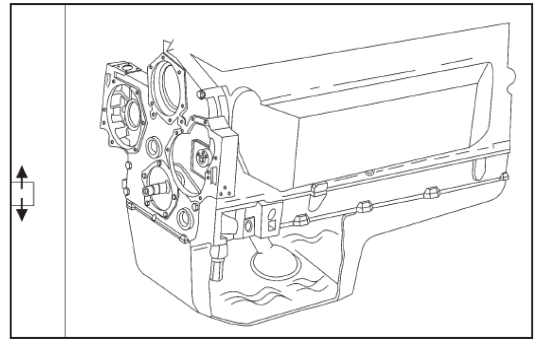

Remove the whorl plug, prepare a container to collect 20L of oil.

NOTE: *Hot oil can injure people.*

TOOL: 32mm open-ended wrench

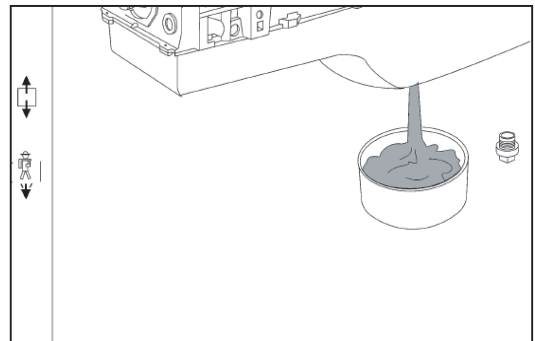

Clean the end surrounding of the filter, and remove it.

TOOL: The special wrench for filter.

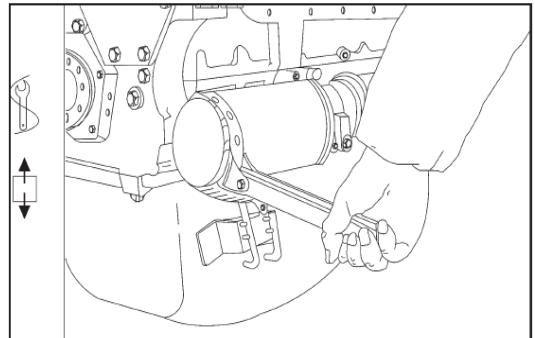

Install the new oil filter.

NOTE: *Adjust the seal ring and smear some lubricating oil on it while fitting the oil filter.*

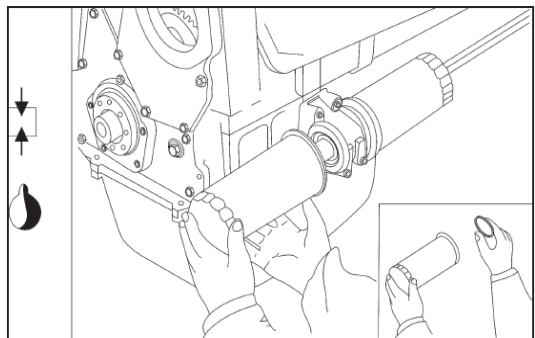

Check and clean the screw thread and seal ring, and then install the whorl plug.

TOOL: 32mm open-ended wrench

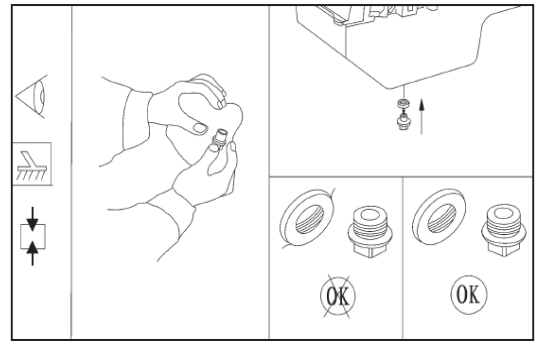

Fill the clean oil up to the upper limit, the capacity of the oil sump is 20L.

NOTE: Oil details refer to page 28

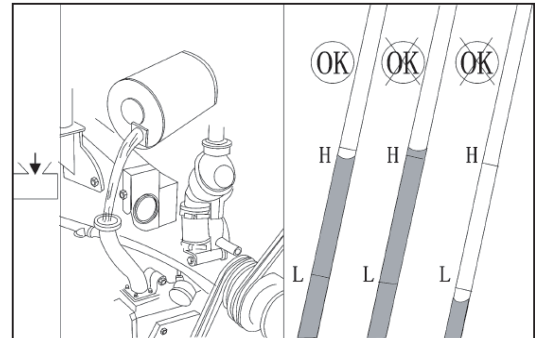

Run the engine at idling speed and check the filter to find whether it leaks or not.

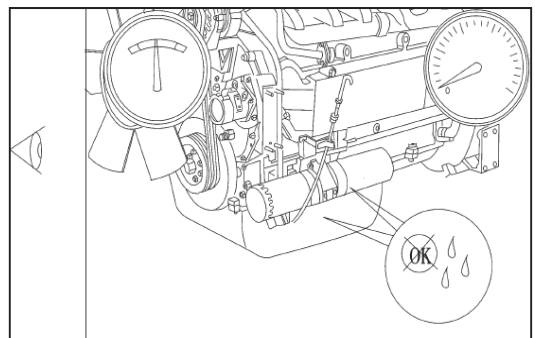

Stop the engine and make the oil run into the sump from the upper parts 5 minutes later, then check the oil level, fill oil up to the upper limit if necessary.

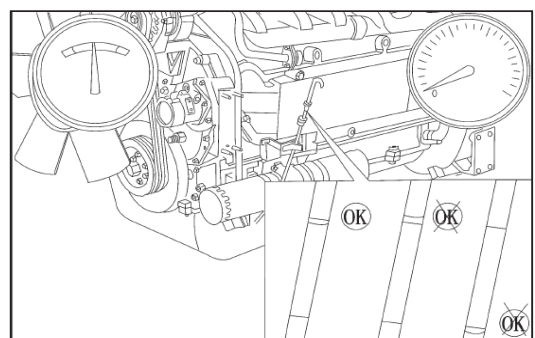

Check and adjust the valve clearance.

Disassemble 6 cylinder head covers.

TOOL: 13mm sleeve wrench

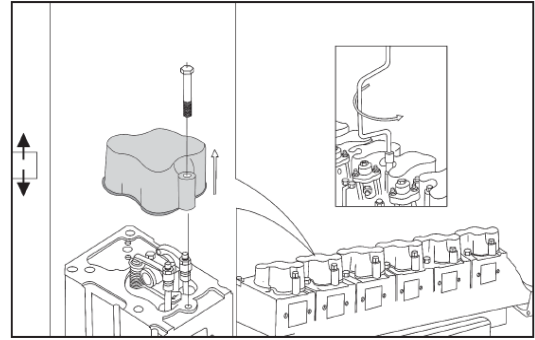

Turn the flywheel until its OT scale and the mark on its housing are aligned, push the piston to the position of TDC of compression stroke of 1st cylinder(the intake and exhaust valve of 1st cylinder are closed) .

TOOL: 32mm wrench for turning the crankshaft

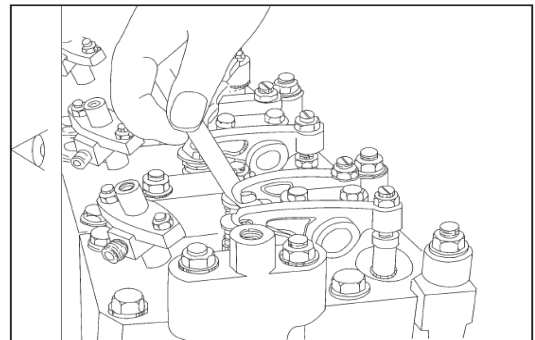

The clearance of intake valve is 0.30mm

The clearance of exhaust valve is 0.40mm

NOTE: *When check the clearance of valve , the engine should be at the Cool condition—its temperature is less than 60°C . When the clearance gauge glides between the top of valve rod and rocker arm and can be felt retarded and sticky , the measuring result is proper .*

TOOL: Clearance gauge

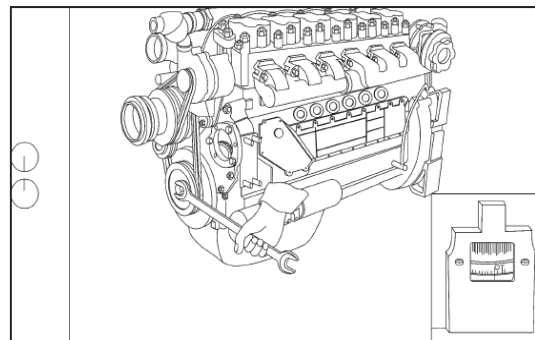

The piston of 1st cylinder is at TDC of the compression stroke.

Check and adjust the valve clearance as step A(I-air intake Valve E-air exhaust valve)

Adjust the clearance by gauge and tighten the fixing nut of rocker arm , re-check the clearance till it meets the requirement.

TOOL : 6# screwdriver and 14mm double offset ring wrench.

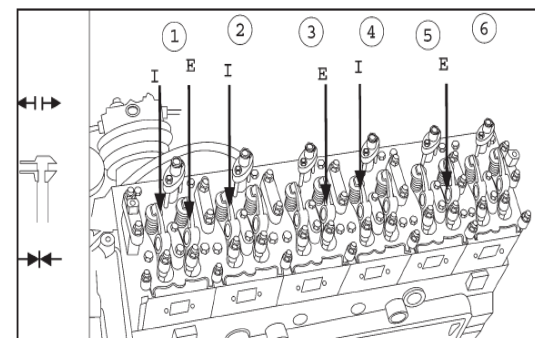

Turn the crankshaft 360° by the spanner; it can also be turned 360° after marking on the vibration damper.

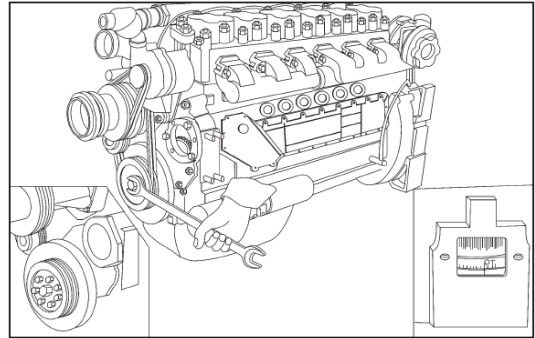

Adjust the valve clearance as step B Loosen the fixing nut of rocker arm, adjust the clearance by gauge then tighten the nut again.

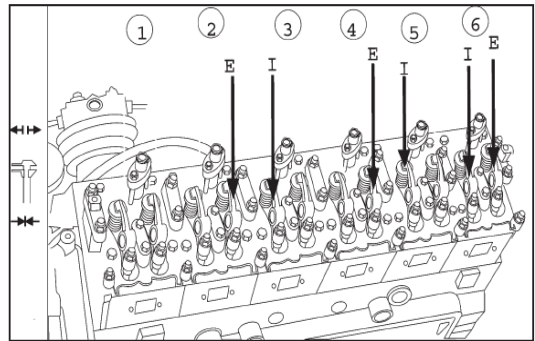

Install the gasket and cylinder head cover.
The tightening torque of bolt is 23N·m (recommended)
Tool: 13mm sleeve wrench

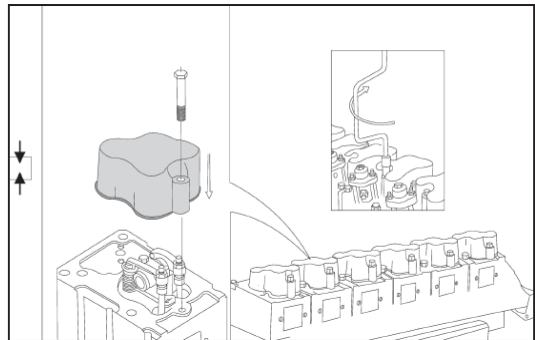

Check the tension of V-belts Measure the flexibility of the V-belt at the middle of its biggest span, generally the requirement result should be less than 10mm under strong press by your thumb.

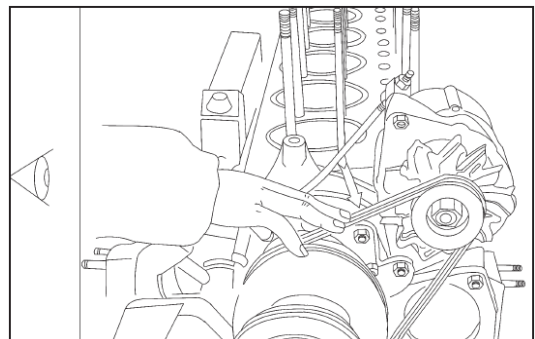

16mm open-ended wrench If the flexibility is more than 10mm, it means the V-belt has been loosen. The nut for tension pulley needs to be relaxed, strain the V-belt again and tighten the nut.

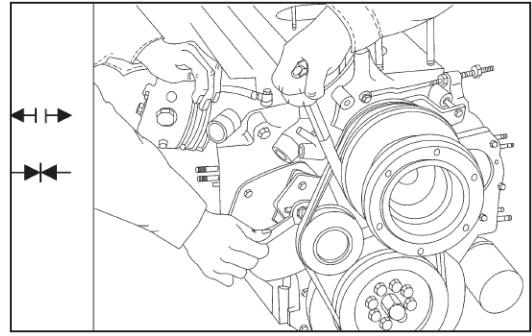

Check whether the rubber pipes of cooling system is aging or cracked, the steel wire hoop is loosening. If it is necessary, tighten or replace the parts to ensure good sealing performance.

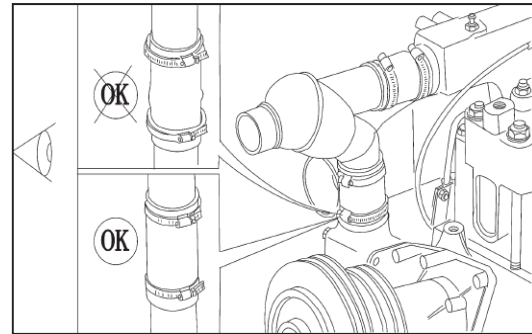

Add the following maintenance contents every 500h (20, 000 Kilometers)
Replace the fuel filter.
Tool : 13mm open-ended wrench

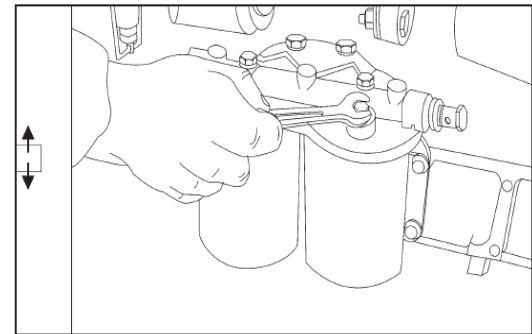

Clean the end surrounding of the fuel filter, unloosen the upper bolt and disassemble the fuel filter.
Install the new fuel pre-filter element and filter element.

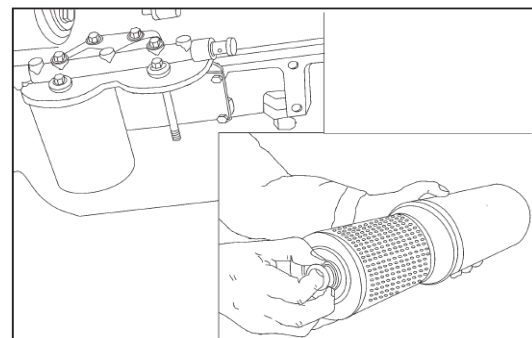

Install the replaced fuel filter on the bracket and tighten the bolt.

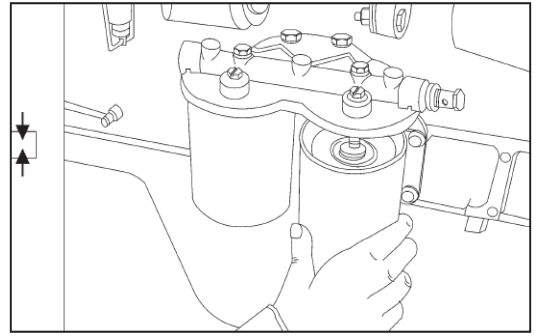

Drain off the air from the fuel delivery pipe and fuel filter
Open the fuel draining bolt at the inlet of injection pump

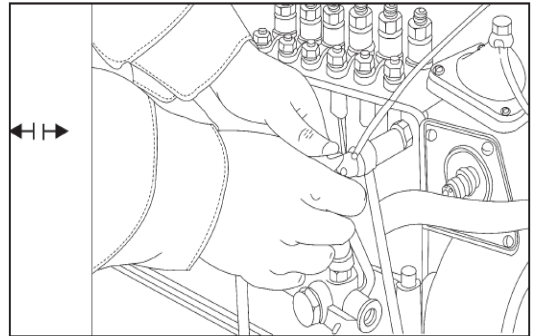

Press the fuel delivery pump plug till the fuel drained off from the draining bolt outlet does not contain air, then tighten the bolt.

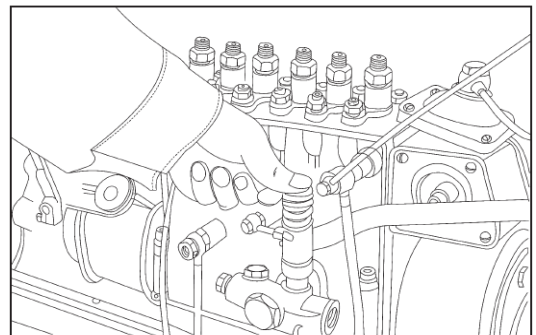

Check the air intake system

Check whether the air intake rubber pipes are aging or cracked, the steel wire hoop is loosening. If it is necessary tighten or replace the parts to ensure good sealing performance.

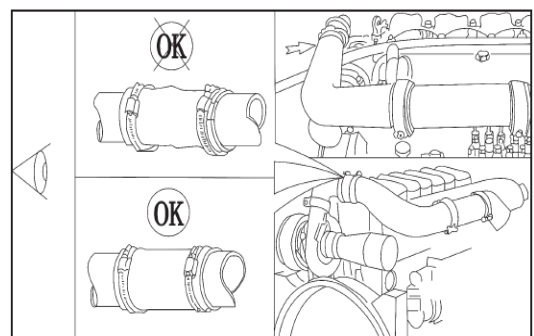

Check the air filter element

The max. permitted inlet resistance of diesel engine is 7kPa, and the max. inlet resistance of diesel engine must be inspected with the engine running at rated speed and with full load. When the inlet resistance reaches the max. permitted limited value, clean or replace the element in accordance with the provision of manufacturer.

CAUTION: *It is forbidden to operate engine without air filter, or entrance of dust and impurity into the engine will result in early wear.*

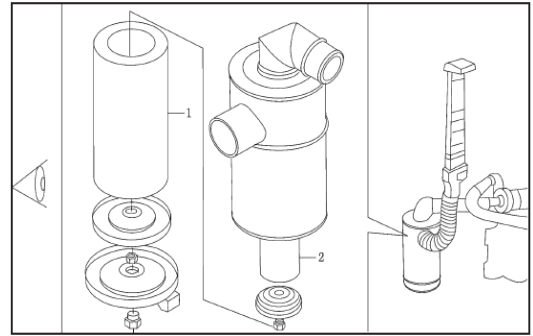

1. Paper filtering element
2. Blankety safety filtering element

Dismantle the element from air filter, and bat the end face slightly in order to make the dust fall down, or blow it reversely with compressed air (blow from inside to outside).

CAUTION: *Do not blow through the filter paper.*

Do not clean the filter paper with water and oil.

Do not bat or knock the element heavily.

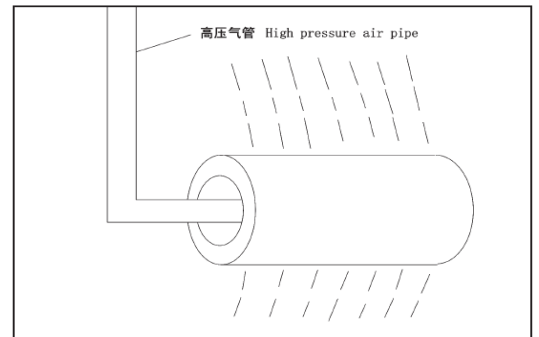

Maintenance during long-term storage

In order to prevent rust and corrosion, the diesel engine is oil sealed before ex-work. Usually, the oil seal period for the diesel engine is one year. Whenever the oil seal period exceeds one year, check and take necessary supplementary measures.

Preservation: First fill the diesel engine with sealing oil and coolant with anti-rust agent, start the engine and run at idling speed for 15~25min. Spray sealing oil to air compressor intake 2min before stopping of the engine. After stop, remove the pipeline connecting intercooler and engine, so that the starter drives the engine to rotate. The sealing oil is sprayed into the cavities of intake pipe, turbo-supercharger, etc. Apply sealing oil on all the exposed surfaces and the extended shaft ends.

Protection in storage period: Block all the oil, air and water inlets and outlets with cap or banded plastic cloth; and seal up the whole diesel engine with weather rust proof film.

Add external package if transportation is needed.

THE MAIN SYATEM FLOW CHART OF ENGINE

- Lubricating system;
- Cooling system:
- Intake and exhaust system;
- Fuel supplying system;

To understand the main system flow chart of the engine will give help to you for operating and maintaining the engine.

Lubricating System

1. Strainer
2. Oil pump
3. Oil filter
4. Oil cooler
5. Main oil passage
6. Safety valve of oil pump
7. Safety valve
8. Oil release valve for main oil passage
9. Bypass valve of oil filter

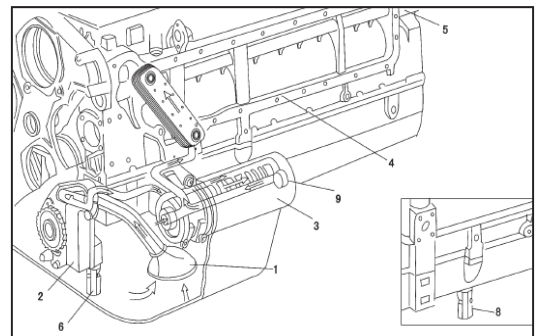

Lubricating for main moving parts

1. The oil flowing from the oil cooler.
2. Main oil passage.
3. Oil to the main crankshaft journal.
4. Connecting rod journal. Connecting rod journal.
5. The main journal of crankshaft.
6. Oil to connecting rod beating.

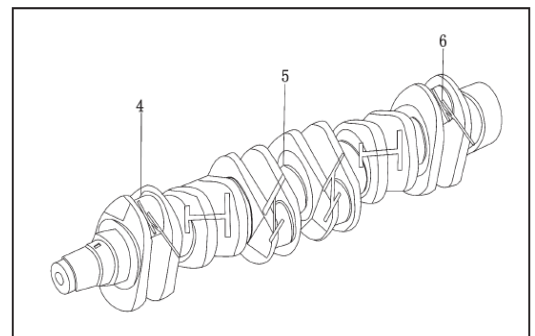
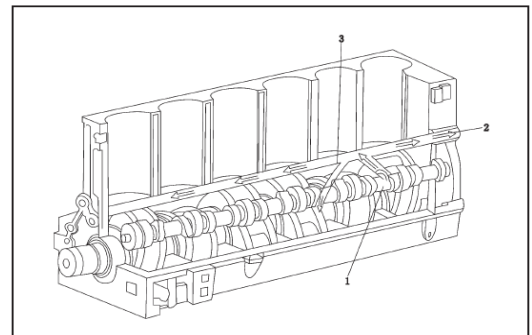

- 7. The branch oil passage passing to main Dearing.
- 8. Sub-passage of oil.
- 9. Oil injection nozzle to Cool piston.
- 10. Camshaft beating.

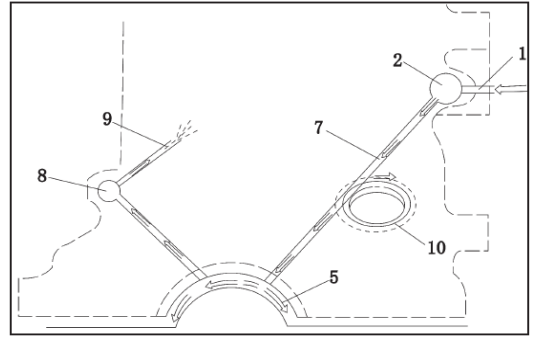

- 11. Lubricating air compressor through the oil from sub-passage.
- 12. Lubricating fuel injection pump through the oil from sub-passage.

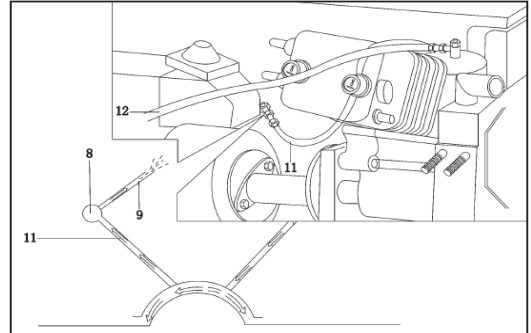

Lubricating for rocker arm system

- 1. Oil flowing from the oil branch
- 2. Tappet oil hole
- 3. Push rod oil hole
- 4. Oil hole of rocker arm bolt
- 5. Oil hole of rocker arm passage

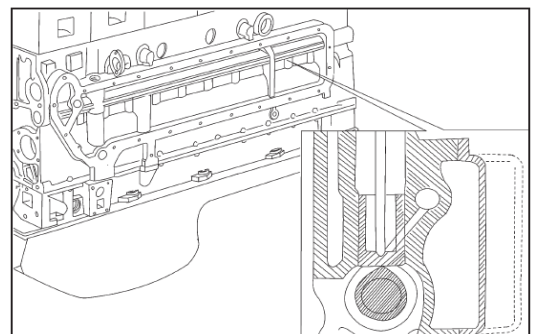
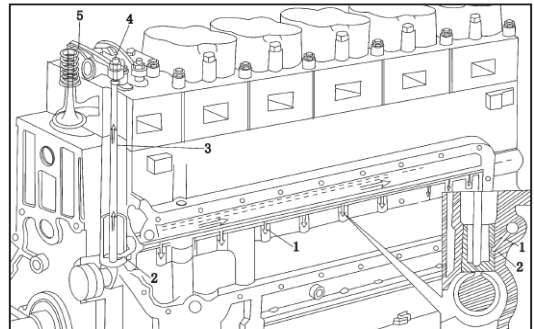

Cooling System

1. Water pump inlet
2. Water pump
3. Water channel of oil cooler
4. Water jacket of cylinder block

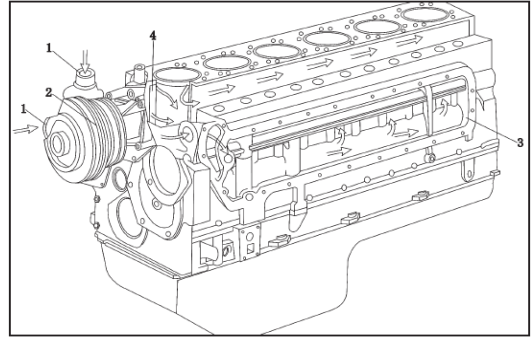

1. Water jacket of cylinder block
2. Cooling water flowing from water jacket of cylinder block
3. Cylinder head gasket
4. Cooling water passing through the water passage of cylinder head
5. Cooling water outlet

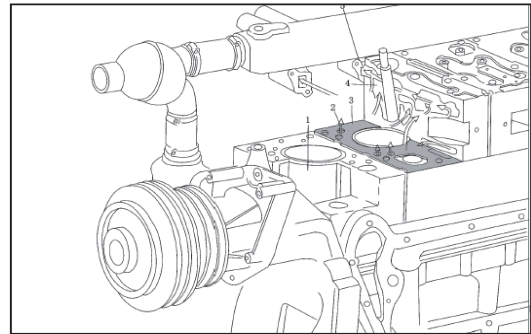

1. Coolant flowing from cylinder block
2. Thermostat
3. Bypass valve
4. Coolant flowing into water pump
5. Bypass valve closed
6. Coolant flowing into the radiator

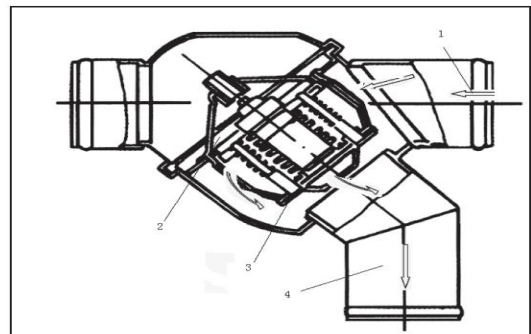
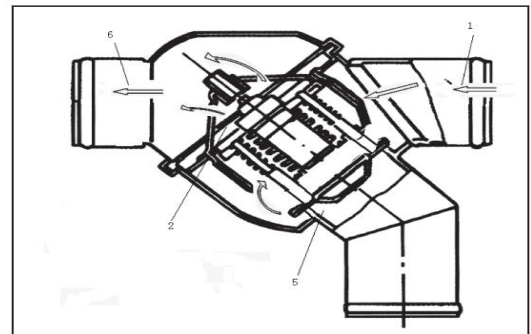

Intake and Exhaust System

1. The fresh air passing through the air filter flows into turbocharger
2. The turbocharged air flows into intake manifold.
3. Intake manifold
4. Intake valve

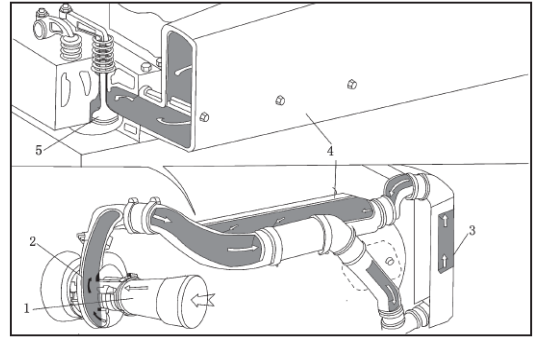

1. Exhaust Valve
2. Exhaust manifold
3. Exhausting gas flowing into the turbo of turbocharger
4. Exhaust outlet of turbocharger

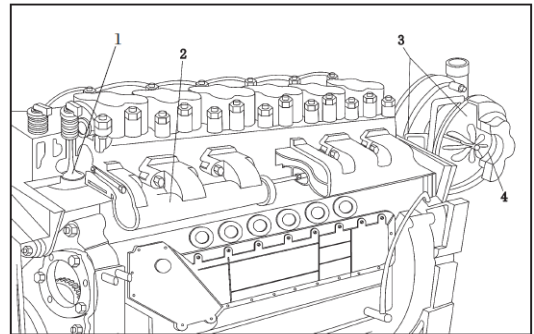

Fuel Supplying System

1. Fuel from the fuel tank
2. Fuel delivery pump
3. Fuel filter
4. Fuel delivery pipe
5. Air connecting pipe for smoke controlling device
6. Fuel injection pump
7. High pressure fuel pipe
8. Injector
9. Fuel returning pipe of Injector
10. Fuel pipe back to the fuel tank

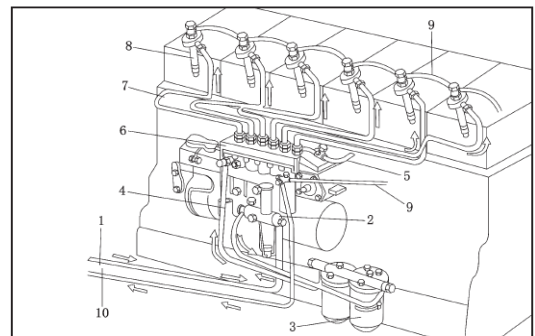

TIGHTENING TORQUE AND TIGHTENING METHOD OF HIGH STRENGTH BOLTS

Main-Bearing Bolt:

Total nos.:14pcs M18 bolts

Tool: 22mm sleeve wrench

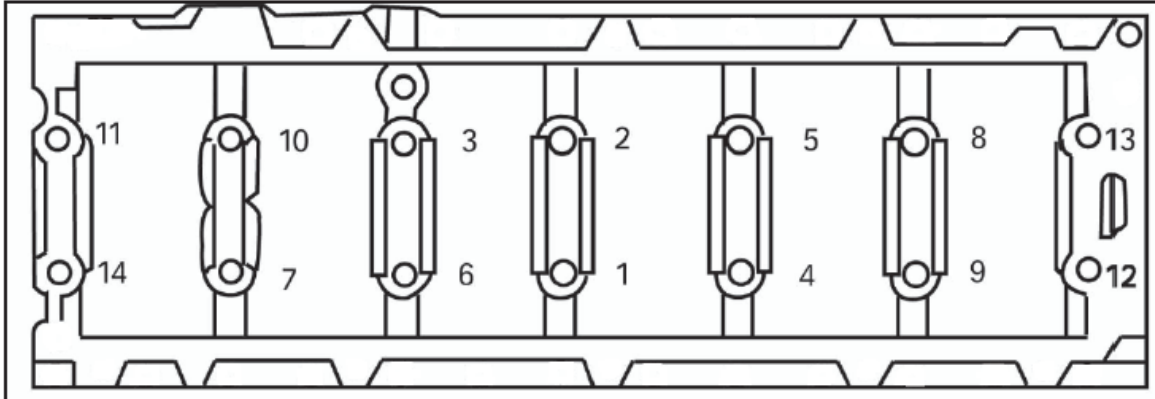

Tighten bolts in twice (tightening sequence see the figure above)

The first time: 80N·m

The second time: 250+25N·m

Cylinder Head Bolt:

Total nos.: 24pcs M16 main bolts, Tool: 22mm sleeve wrench

Total nos.: 21pcs nuts of M12 auxiliary bolt, Tool: 17mm sleeve wrench

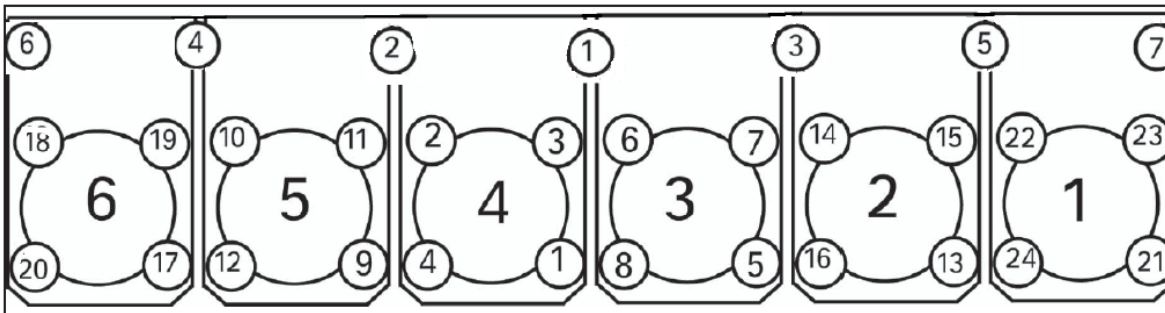

Following such tightening sequence:

Step 1: Align cylinder head after assembly, i.e. the exhaust port side of cylinder heads should be in the same plane. All the bolts should be tightened beforehand, and the torque is 30 N·m.

Step 2: Tighten 24pcs main bolts as the sequence in above figure, and the torque is 200N·m.

Step 3: Tighten 21pcs auxiliary bolts as the sequence in above figure, and the torque is 100N·m.

Step 4: Turn the main bolts 90° as the sequence in above figure.

Step 5: Turn the auxiliary bolts 90° as the sequence in above figure.

Step 6: Turn the main bolts 90° as the sequence in above figure again, and the torque range is 240—340N·m.

Step 7: Turn the auxiliary bolts 90° as the sequence in above figure again the torque range is 120 ~ 160N·m.

Replace those bolts that cannot reach required torque range. The main bolt is allowed to be reused for 3 times, and the auxiliary bolt is allowed to be reused for 2 times.

Connecting rod Bolt : Connecting rod Bolt :

Total nos. : 2pcs M14x1.5 for each connecting rod

Tool: 19mm sleeve wrench

Step 1: Tighten tightly, then tighten these bolts symmetrically with a torque of 120N·m.

Step 2: Turn these bolts 90°±5°. and the torque range is 170 ~ 250N·m.

Replace those bolts that can not reach required torque range.

NOTE: *The connecting rod bolts that have been used should not be reused .*

Flywheel Bolt :

Total nos.: 9pcs M14x1.5

Tool: 22mm sleeve wrench.

Step 1: Tighten these bolts symmetrically with a torque of 60N·m.

Step 2: Turn these bolts 180°±5°, and the torque range is 230 ~ 280N·m.

Replace those bolts that can not reach required torque range.

NOTE: *The flywheel bolt is only allowed to be reused for 2 times .*

Bolt for Flywheel Housing :

Total nos.: 13pcs M12 bolts

Tool: box wrench

Step 1: Tighten these bolts with a torque of 40N·m.

Step 2: Turn these bolts 120°±5° respectively, and the torque range is 110-140N·m.

Replace those bolts that can not reach required torque range.

The flywheel housing bolt is allowed to be reused for 2 times.

NOTE: *Smear thread and bearing surface of high strength bolts described above with lubricating oil before tightening .*

Bolt for Intermediate Gear Shaft

Total nos.: 4pcs M10 bolts

Tool: sleeve wrench

Step 1: Tighten these bolts symmetrically with a torque of 60N·m.

Step 2: Turn these bolts 90°, and the torque range is 100~125N·m.

Replace those bolts that can not reach required torque range.

Smear the thread with Loctite 242 thread locker before tightening.

The bolt of intermediate gear shaft is allowed to be reused for three times.

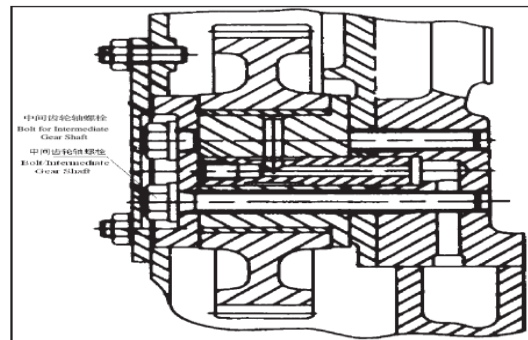

Bolt / Oil Pump Idler Gear Shaft

Total nos.: 1 piece M 10 bolt

Tool: 16mm sleeve wrench Tighten the bolt with a torque of 60⁺⁵ N·m.

Coat the thread with LOCTITE 242 THREADLOCKER.

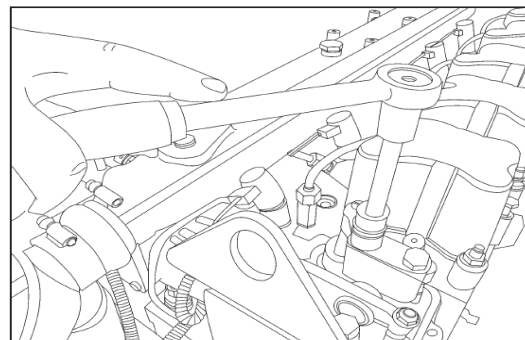

Bolt / Rocker-Arm Support

Total nos.: 12pcs M12 bolts

Tool: 18mm sleeve wrench these bolts with a torque of 100N·m.

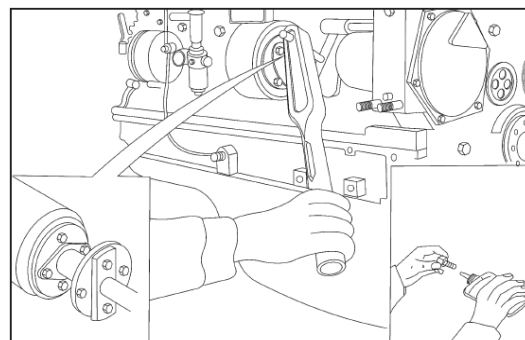

Hex head Bolt/Binding Coupling and Injection Pump

Total nos.: 1 piece M14x1.5 bolt.

Tool: 18mm box wrench the both with a torque of 150⁺¹⁵ N·m.

Coat the thread with LOCTITE 242 THREADLOCKER before tightening

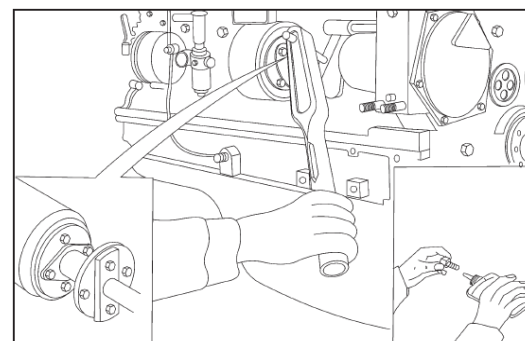

Tight Nut/Injection Pump Driving Gear

Total nos.: 1 piece M24x1.5 nut

Tool: 36mm sleeve wrench

Tighten the nut with a torque of 450~500N·m.

Coat the thread with LOCTITE 242 THREADLOCKER before tightening.

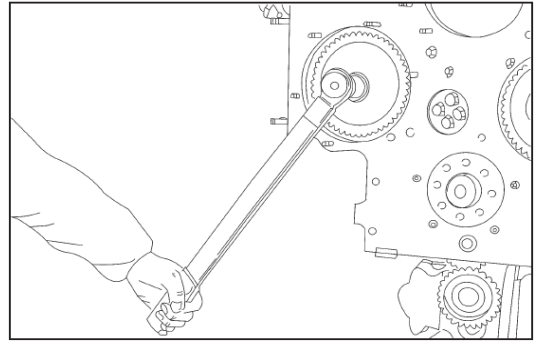

Bosh Camshaft Gear

Total nos.: 4pcs M8 bolts

Tool: 13mm sleeve wrench

Tighten these bolts symmetrically with a torque of 35N·m.

Coat the thread with LOCTITE 242 THREADLOCKER before tightening.

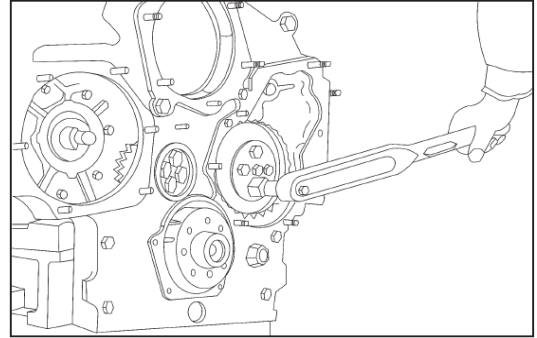

12Bolt/Attaching Damper Pulley and Crankshaft

Total nos.: 8pcs M10 bolts

Tool: 16ram sleeve wrench

Tighten these bolts symmetrically with a torque of 60₀⁺⁵ N·m.

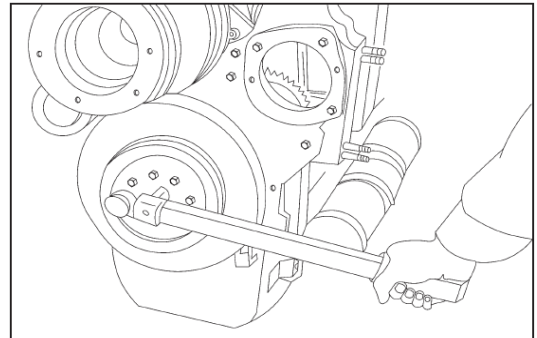

Tight bolts / Attaching Injection Pump and Bracket

Total nos.: 4pcs M10 socket head bolts

Tool: 6mm inner hexagon wrench

Tighten these bolts in sequence, and the torque is 45₀⁺⁵ N·m.

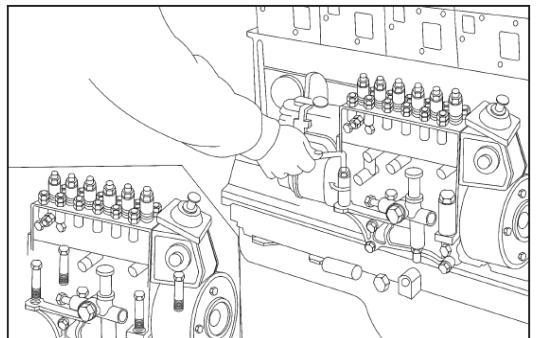

Bolts/Exhaust Manifold

Total nos.: 12pcs M 10 bolts

Tighten these bolts symmetrically with fl torque of (65~80)N·m.

NOTE: Coat the thread and bearing surface with Molybdenum disulfide Lube before tightening .
The exhaust pipe bolt is allowed to be reused for twice.

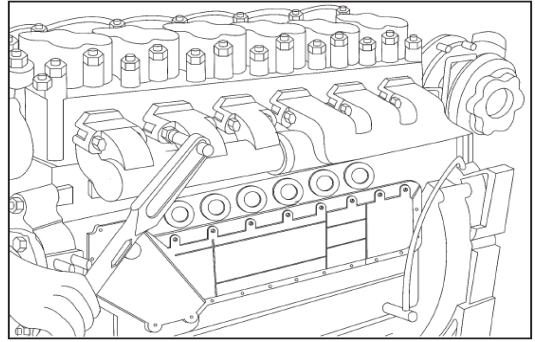

FUEL, LUBRICANT, COOLANT AND AUXILIARY MATERIALS FOR DIESEL ENGINE

Fuel

In summer: No.0 diesel fuel (GB252)

In winter: No.-10 light diesel fuel GB252. When the temperature in winter is lower than -15°C , use No.-20 diesel fuel. When the temperature in winter is below -30°C , use No.-35 diesel fuel.

Oil

Volume of oil: 16L, however, the lubricant volume is measured by the dipstick.

Selection of oil: For the safe and reliable running of the diesel engine, please choose oil grade 15W/40CF-4 or 20W/40CF-4. Grade 15W/40CF-4 oil can be used within the range of $-15^{\circ}\text{C} \sim +30^{\circ}\text{C}$ while grade 20W/40CF-4 oil should be used in the range of $-10^{\circ}\text{C} \sim +30^{\circ}\text{C}$ (Weichai special engine oil is recommended).

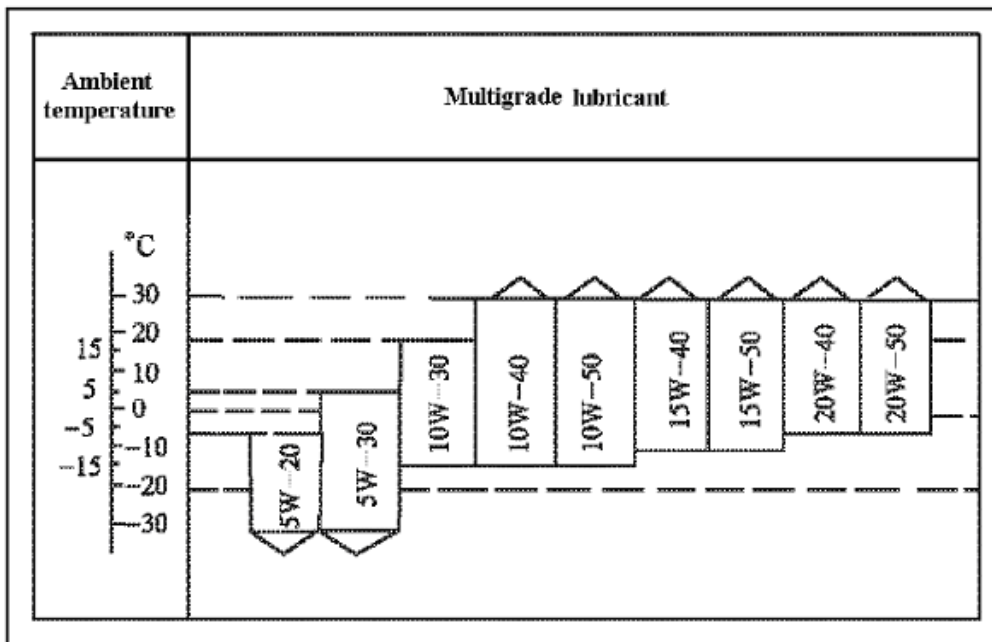

Antifreeze additive of engine cooling system

The commonly used antifreeze additive is ethylene glycol. Long-acting antifreeze additive with reliable quality made in China is allowable. Refer to relevant instructions for the detailed methods employed. Recently recommended long-acting antifreeze additives in China are: long-acting antifreeze additive JFL-336 and long-acting antifreeze additive FD-30 #.

CAUTION: Periodically replace the long-acting antifreeze additives as per relevant requirements.

Calculation of the antifreeze additives (for reference only):

Total capacity of the coolant: 30L (filling the engine with a radiator)

Inspection temperature of the antifreeze right now: -20°C

The lowest antifreeze temperature required: -30°C

Calculation methods: Get the point of the coolant total amount "30L" on the x-coordinate; draw a line across this point and find intersection 1 and intersection 2 of the -20°C slant and the -30°C slant (refer to Fig. 6-1).

Get: the amount of anti-freeze additive at -20°C is 13.5L; the difference of the anti-freeze amount at -30°C and that at -20°C is 4L.

As for the 4L difference value, must add 50% of the amount to calculate. Because before filling the antifreeze additive, some coolant must be drained. Then, the antifreeze additive mixed with.

Auxiliary Materials List of 5ton Diesel Engine

Serial No.	Name	Color	Function and Application
1	Fine Molybdenum Powder	Black	Apply to smooth surface of metal to prevent biting. eg: Apply to exterior surface of cylinder liner.
2	Molybdenum disulfide Lube	Dark Grey	To prevent adhesion of parts under higher temperature. eg, Apply to the bolts of exhaust outlet of turbocharger.
3	Loctite 242 glue	Blue	Apply to thread to seal. eg, Apply to bolts and thread.
4	Loctite 262 glue	Red	Apply to thread to lock and seal. eg, Apply to auxiliary bolts of cylinder head.
5	Loctite510 glue	Red	Apply to surface of metal to seal. eg, Apply to bond surface of cylinder block and crankcase.
6	Loctite 271 glue	Red	Apply to surface of metal to seal. eg, Apply to oil channel plug.
7	Loctite 277 glue	Red	Sealing of plug and hole. eg, Apply to the water reservoir plug of cylinder block.
8	Lithium Grease	Achromatic Color	Grease for Water Pump

NOTE: To ensure the proper operation of our diesel engines , please use the correct brand fuel and oil as this manual described .

ELECTRICAL APPLIANCE

This section consists of generator, starter, sensor of water temperature indicator, induction plug of oil pressure, etc.

Generator

The generator is three-phase alternator, after silicon rectification the current change into direct current.

Output Voltage : 28V DC

Current : 27A(In order to meet customer's demand, the currents of 35A and 55A are available for option)

Rotation Direction : clockwise

Maximum Allowable Speed : 11000 r / min

Rated Load Speed : 6000 r / min

Circuit Diagram :

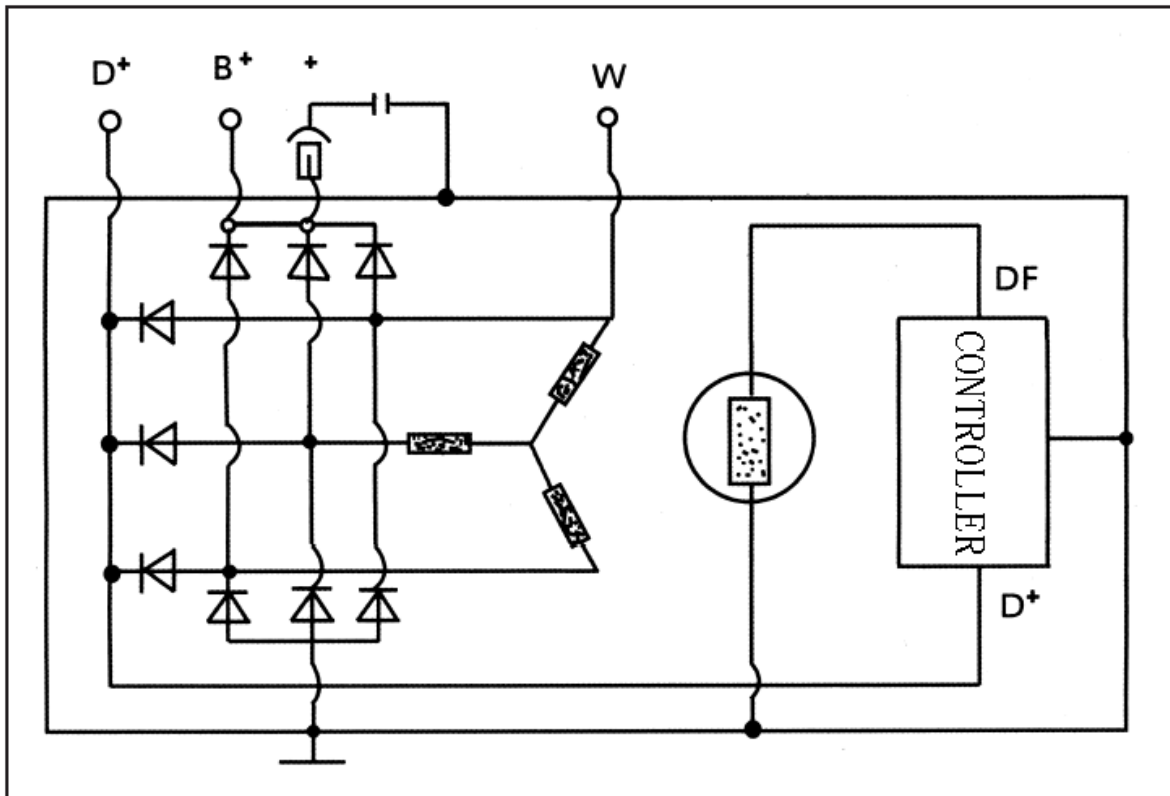

Connection Pole D+ connect to Charging(electrification)Indicating Lamp, the screw specification : M4

W connect to Speed Measuring Motor, the screw specification : M5

B+ connect to the positive electrode of battery, generator shell is grounded, the screw specification : M6

Starter

The starter is DC starter, Voltage : 24V, Power : 5.4kW, 7.5kW or 8.1 kW, Rotation Direction: clockwise (View direction : face to the output end of the engine)

The starter of which mode number is 3 is divided into two types: 9-tooth (used for SAE II flywheel housing) and 11-tooth (used for SAE I and 6135 flywheel housings). (7.5kW and 8.1kW 9-tooth starters are not available currently). The starter of which mode number is 3.5 is divided into two types: 10-tooth and 11-tooth. The 11-tooth is BOSCH pre-meshed starting

Circuit Diagram :

External Connection Pole : 30 connect to the positive electrode of battery, the screw specification : M10
 3 1 grounding the screw specification : M10
 50 connect to the electromagnetic switch the screw specification : M6

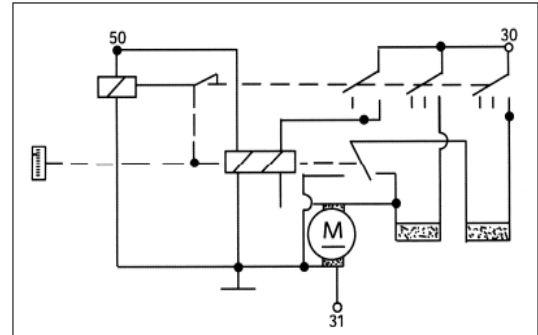

Induction plug of oil pressure

Operating Temperature : -25~100°C Measurement

Range : 0--500kPa

Alarm Pressure : 45~75kPa

Rated Voltage : 6~24V

Sensor of water temperature meter

Operating Temperature : -25 ~ 120°C

Rated Voltage : 6~24V

Battery 2x12V 135Ah or 165Ah or 195Ah 2×12V 135Ah or 165Ah or 195Ah

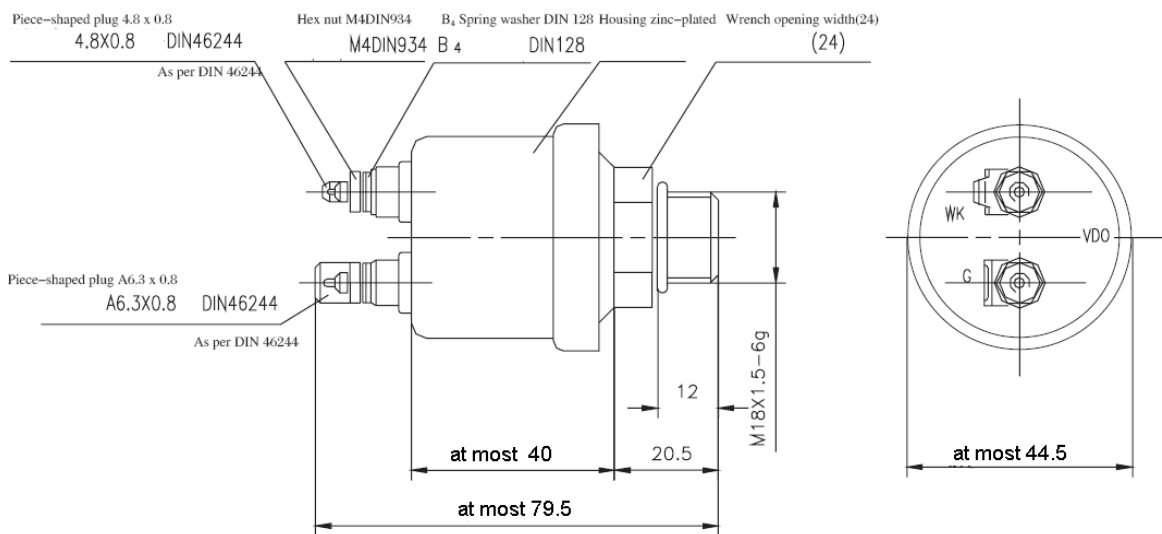

ADJUSTMENT AND REPLACEMENT OF MAIN COMPONENTS

Cooling System

Replace the V-belts

Loosen the tightening nut of the generator to remove generator belt.

Tool: 16mm open-ended wrench

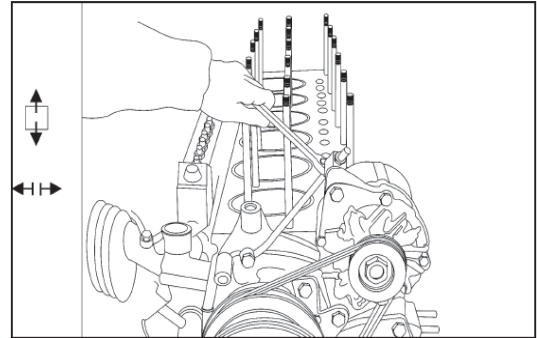

Loosen the M10 self-lock nut (2) of tension pulley, remove the V-belt of water pump.

Tool: 16mm open-ended wrench

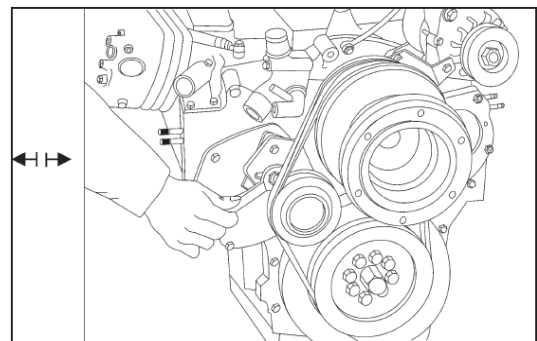

Replace the V-belts, tighten self-lock nuts (2) and the nuts of tension bolts again.

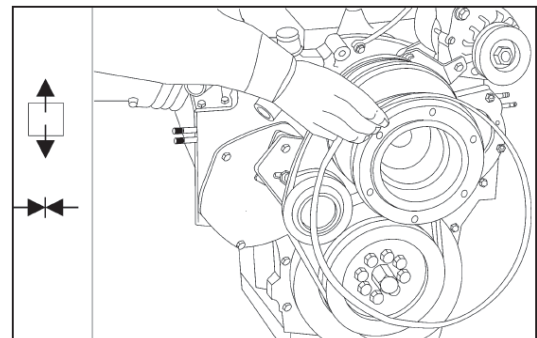

Replace Water Pump

Loosen the tightening bolts of generator to remove the V-belt.

Tool: 16mm open-ended wrench

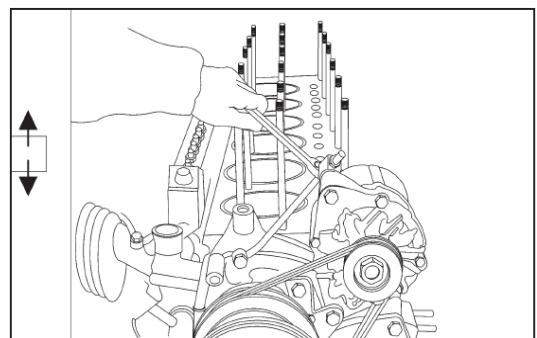

Loosen the bolt from the generator mounting plate.

Tool: 13mm open-ended wrench

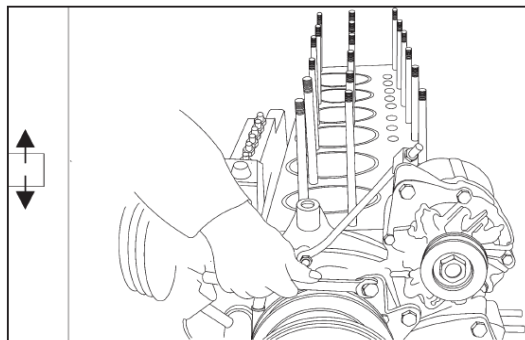

Remove the tightening bolts and hexagon nuts attaching gear case.

Tool: 13mm open ended wrench

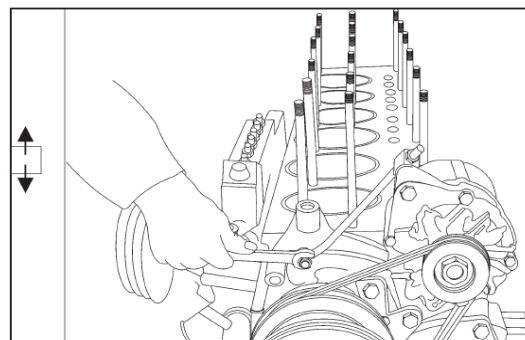

Remove generator.

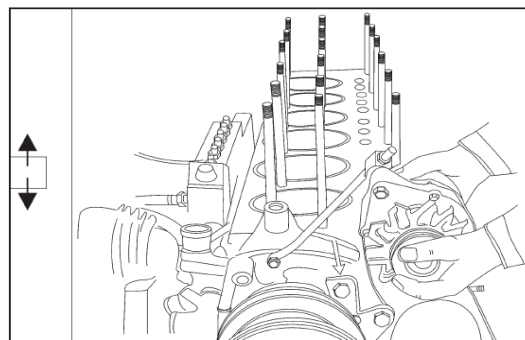

Loosen the hexagon lock nuts of tension pulley to remove the V-belt of water pump.

Tool: 16mm open-ended wrench

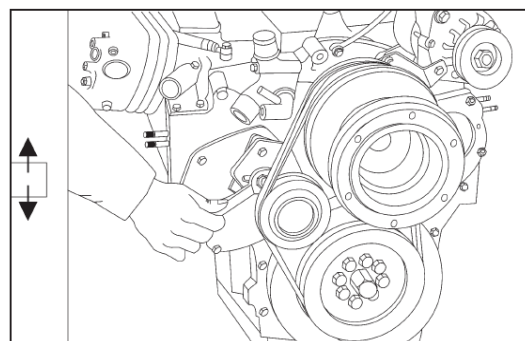

Loosen the rubber hose clamp of water pipe joint.

Tool: 6#Screwdriver

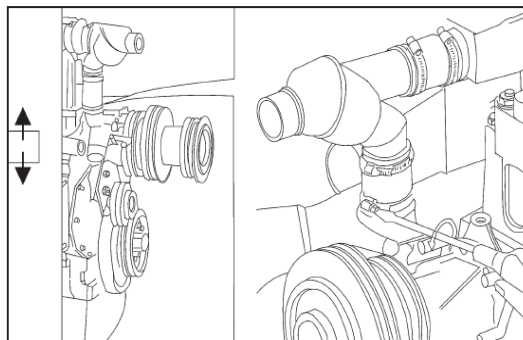

Loosen the bolt of water pipe joint to remove water pipe joint.

Tool: 13mm sleeve wrench

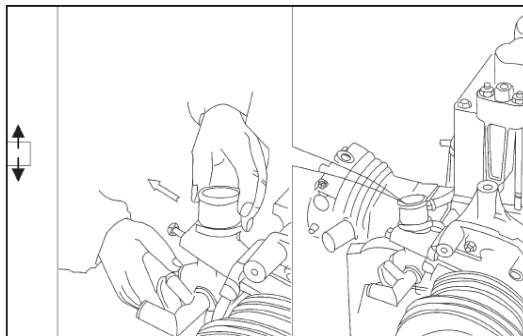

Loosen the 6 hexagon nuts attaching water pump and gear case.

Tool: 13mm open-ended wrench

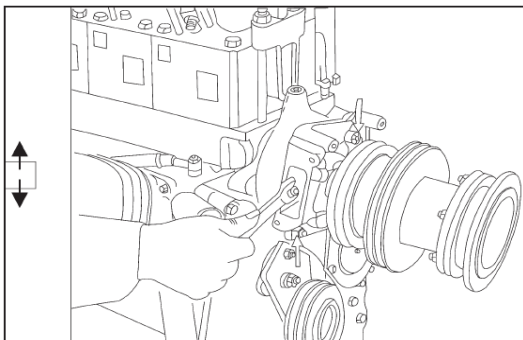

Remove water pump.

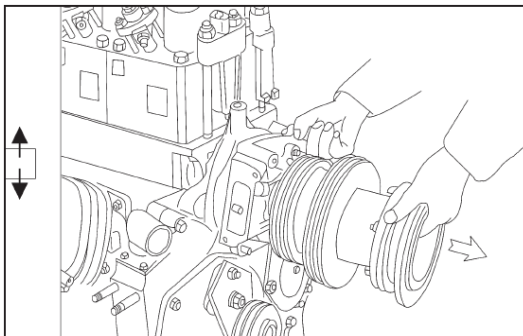

Clean the seal surface of water pump.

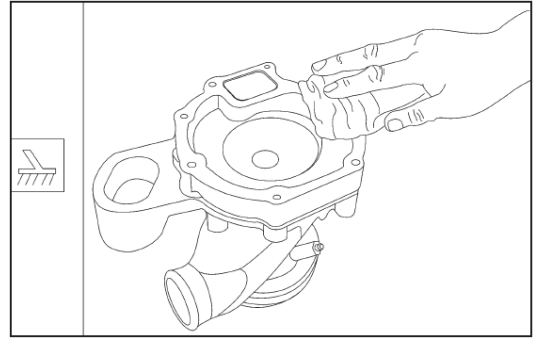

Replace the seal gasket of water pump.

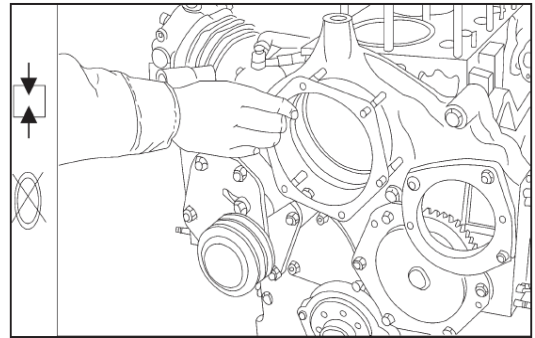

Install the new water pump assembly, tighten 6 hexagon nuts. (There is a nut in the inner side of water pipe joint).

NOTE: Fill the Lumen of water pump with 120cm³ general Lithium grease . Refill lithium grease With grease cup periodically .

Tool: 13mm open-ended wrench

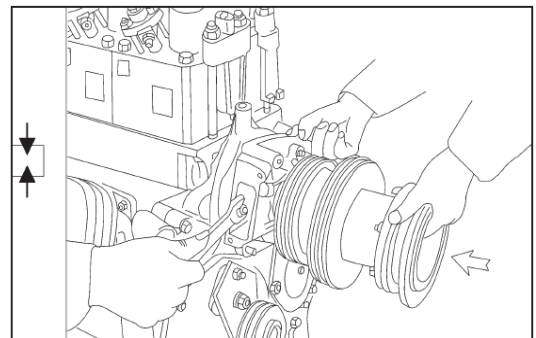

Install the water pipe joint, tighten two M8 bolts of water pipe joint, then install the rubber hose.

Tool: 13mm open-ended wrench

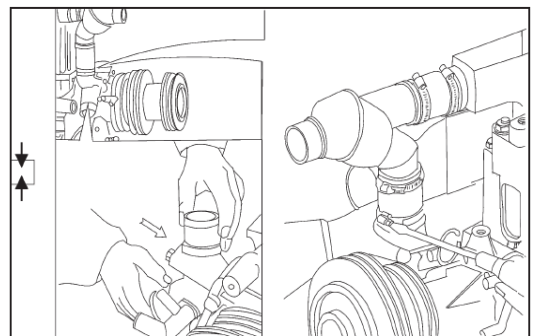

Install generator.

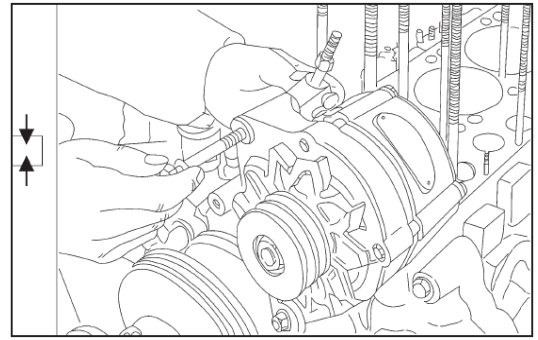

Install the V-belt and adjust the tensely, tighten M10 hexagon lock nuts of tightening pulley.

Tool: 16mm open-ended wrench

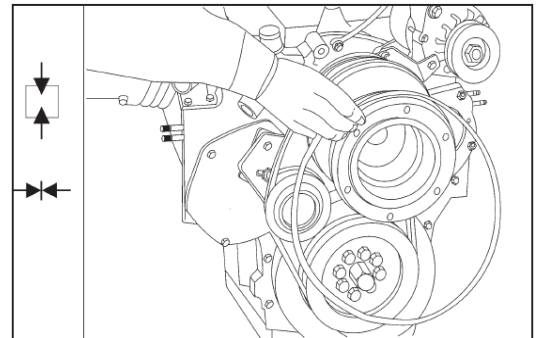

Install the V-belt of generator and adjust the tensely, tighten top nuts of tightening bolts and nuts of mounting plate.

Tool: 13mm and 16mm open-ended wrench

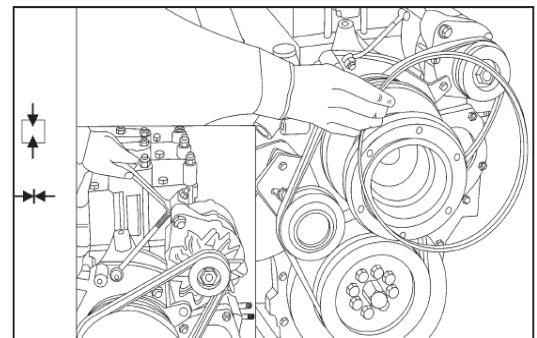

Lubricating System

Replace the oil cooler core

Loosen all of the M8 bolts on the oil cooler cover to remove oil cooler cover (Discharge coolant before demounting the oil cooler cover).

Tool: 13mm sleeve wrench

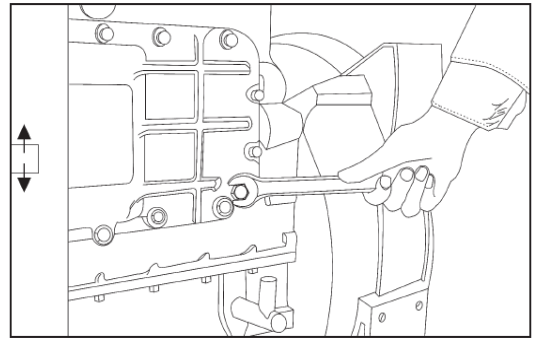

Clean the oil cooler cover and seal surface of the cylinder block, replace with new gasket of oil cooler cover.

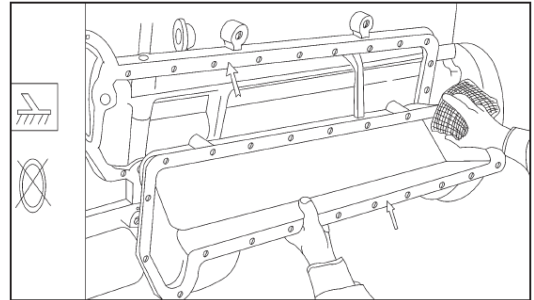

Loosen the 8pcs M 8 bolts of oil cooler element

Tool: 13mm sleeve wrench.

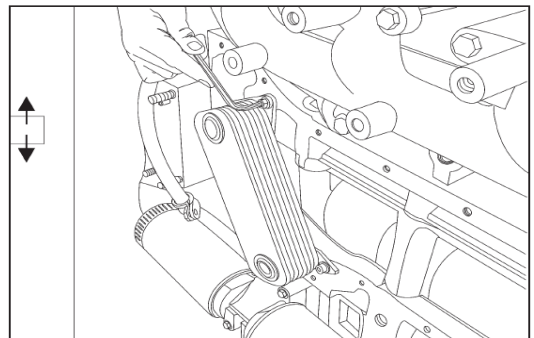

Remove element of oil cooler and clean the bonding surface of flange of oil cooler element.

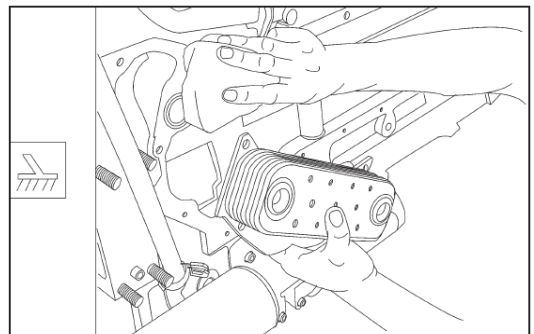

Replace the gasket of oil cooler flange.

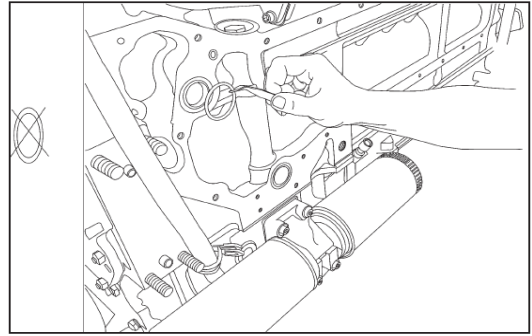

Install the new oil cooler element and tighten the M8 hexagon bolts.

NOTE: Coat the thread with *LOCTITE 242 HEADLOCKER* before tightening .

Tool: 13mm sleeve wrench

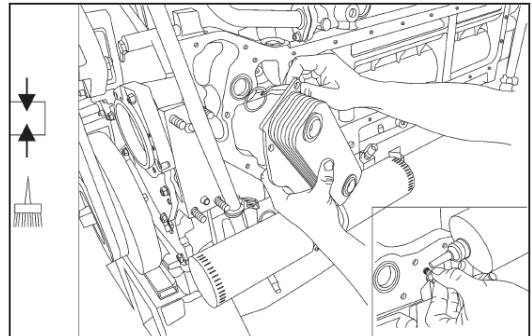

Install the oil cooler cover and tighten all the peripheral M8 hex head bolts.

Tool: 13mm sleeve wrench

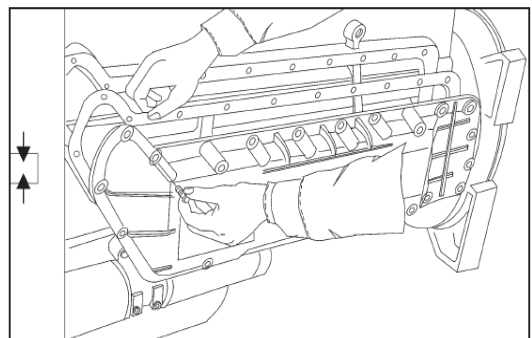

Replace the release valve of main oil channel

Tool: 13mm sleeve wrench

Loosen all peripheral M8 hex head bolts of oil pan.

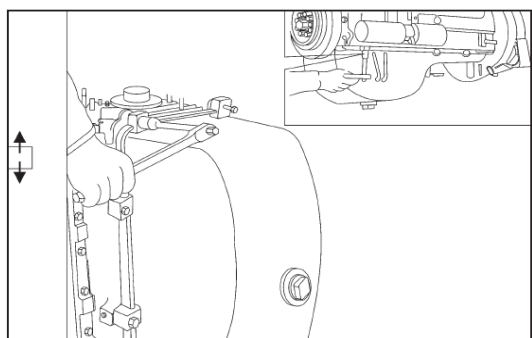

Remove retainer, then remove oil pan.

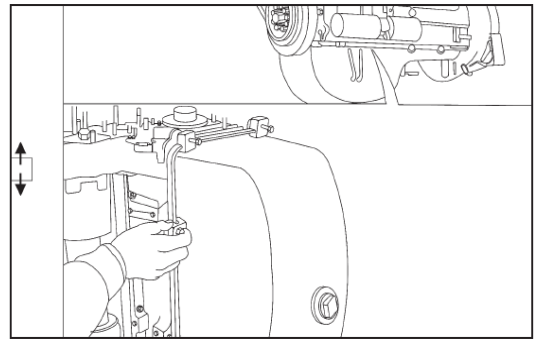

Remove the release valve of main oil channel. When remove the release valve of oil channel, move the male end of hexagonal part on valve body.

Tool: 27mm open-ended wrench

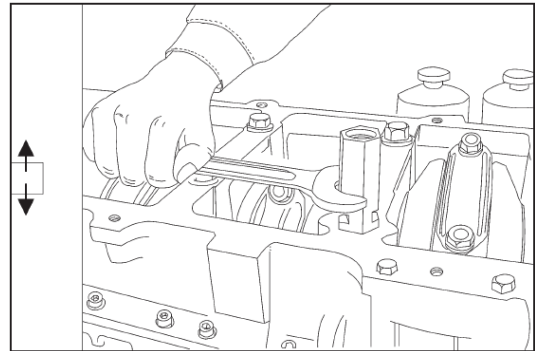

Install new release valve, coat the thread with LOCTITE 242 THREADLOCKER before tightening. When installing new release valve, move the male end of hexagonal part on valve body.

Tool: 27mm open-ended wrench

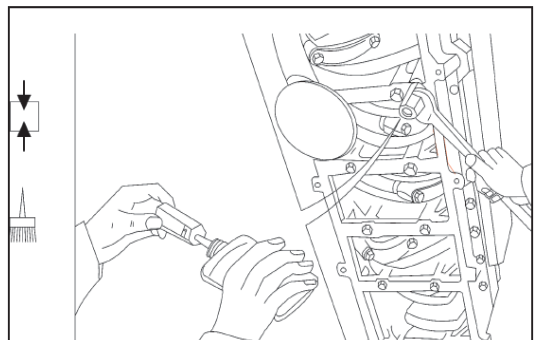

Install oil pan and tighten the M8 hex head bolts.

NOTE: Make sure packing washer of oil pan was pressed well .

Tool: 13mm open-ended wrench

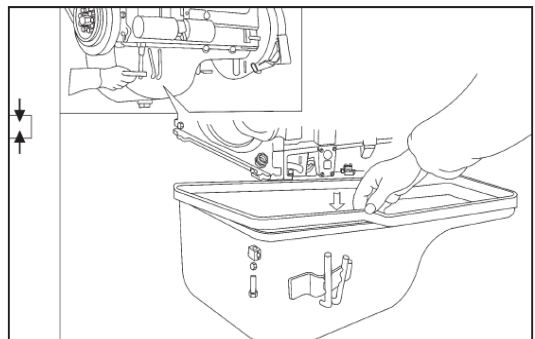

Replace Oil Pump

Remove oil pan and suction pipe.

Tool: 13mm sleeve wrench and 16mm open-ended wrench

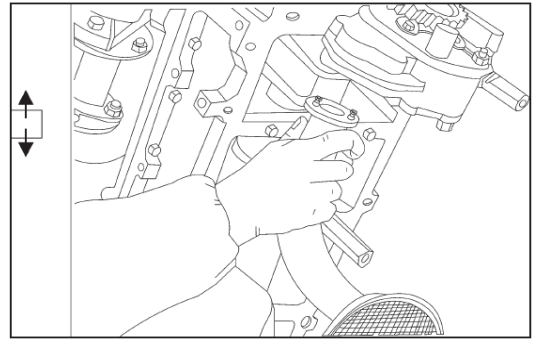

Loosen the mounting plate of oil suction pipe (two-stage oil pump).

Tool: 10mm open-ended wrench

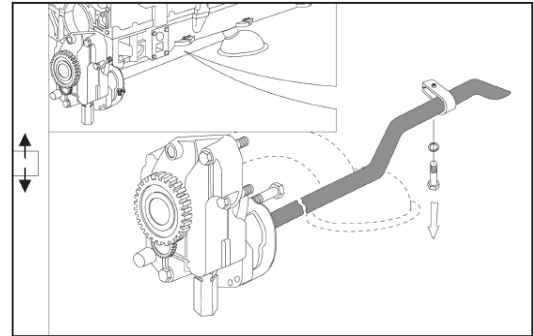

Loosen the M10 hex head bolts of oil suction pipe to remove oil suction pipe.

Tool: 16mm open-ended wrench (two-stage oil pump)

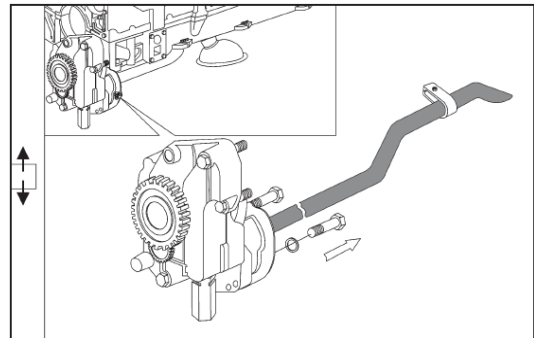

Loosen the hex head bolts of tension pulley and the bolts of crankshaft pulley.

Tool: 16mm open-ended wrench and 16mm sleeve wrench

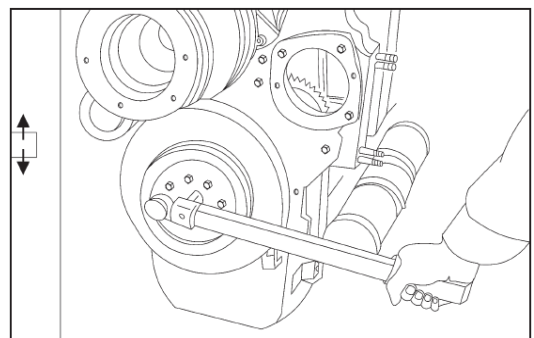

Remove the pulley and damper, the damper and crankshaft is transition fit, the damper can be knocked slightly if it is necessary for removing.

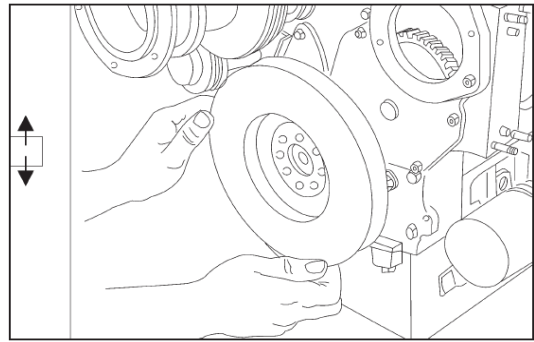

Remove the hex head plug screws of gear case.

Tool: 22mm open-ended wrench

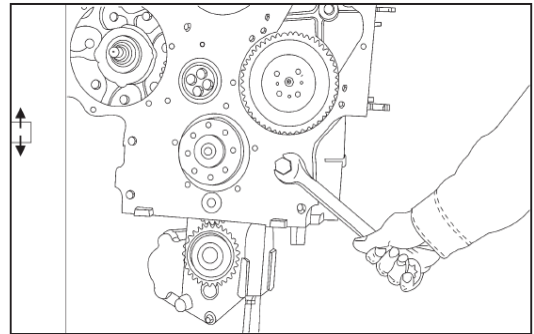

Remove the bolts of intermediate gear shaft of oil pump.

Tool: 16mm sleeve wrench

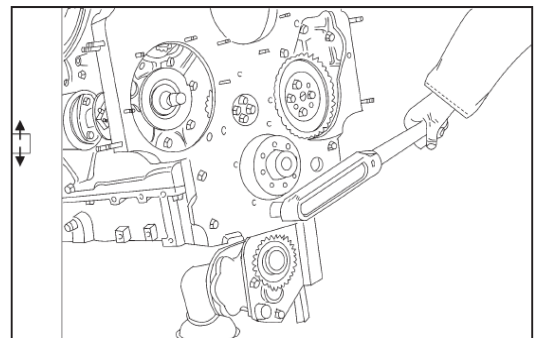

Remove intermediate gear shaft of oil pump with special tool.

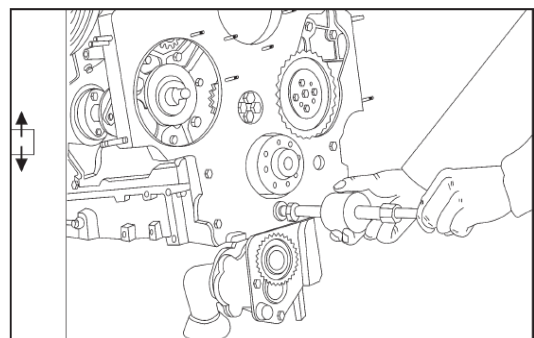

Remove intermediate gear of oil pump.

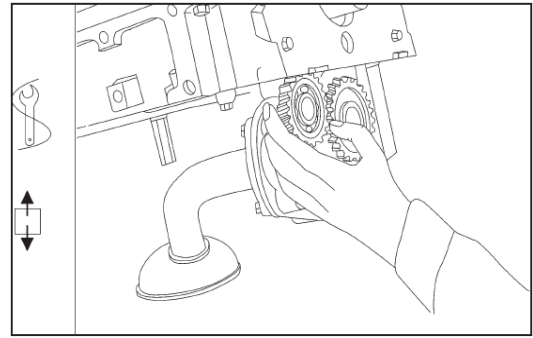

Remove the hex head bolts from the hex plug and another hex head bolt.

Tool: 16mm sleeve wrench

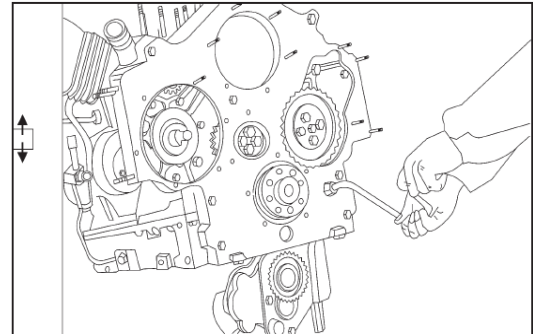

Remove oil pump.

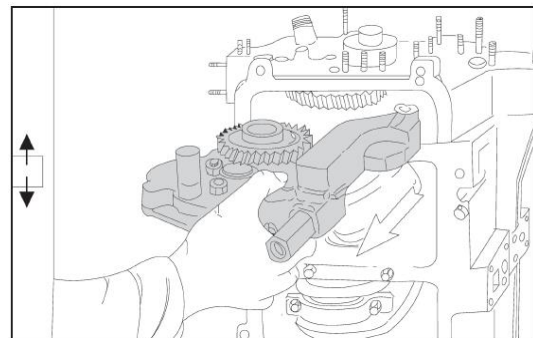

Clean the seal surface between crank Case and Oil pump.

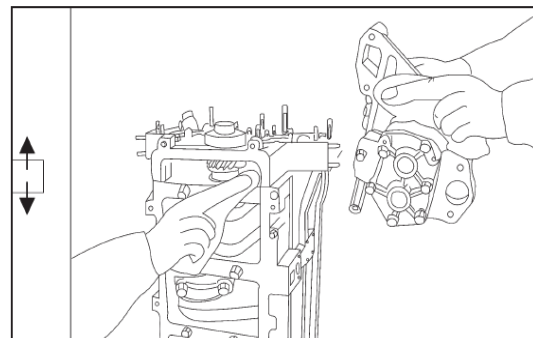

Install new oil pump and gasket, tighten the hex head bolts.

(One of them is in the hex head plug)

Tool: 16mm sleeve wrench

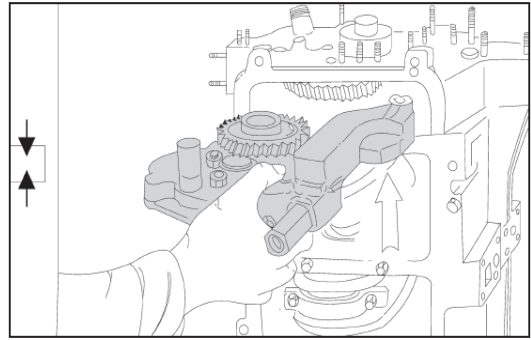

Install intermediate gear of oil pump.

NOTE: convex towards inside

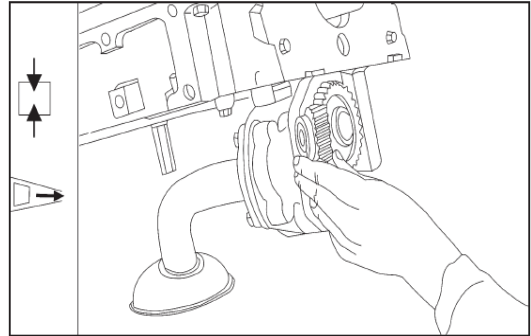

Install intermediate gear shaft of oil pump.

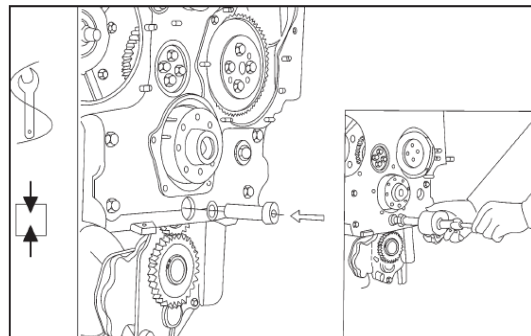

Install the bolts of intermediate gear shaft and tighten them.

Tightening torque : $60 \pm 5 \text{ N}\cdot\text{m}$

Tool: 16mm sleeve wrench

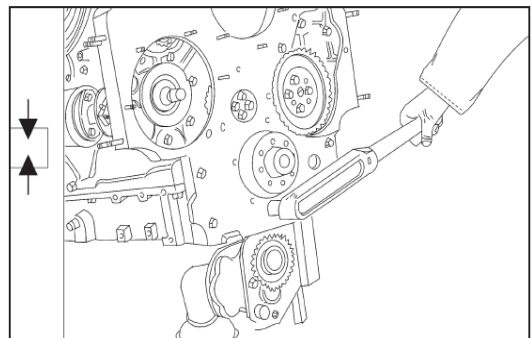

Install damper and pulley.

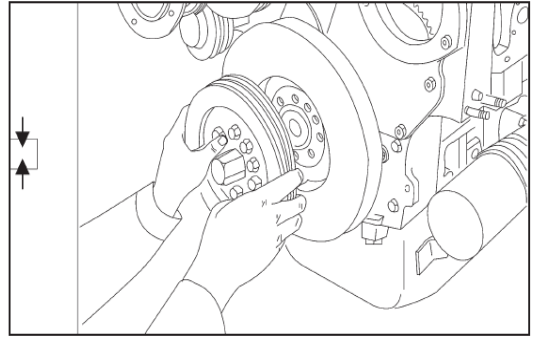

Install the V—belt pulley and adjust the tension, then tighten the hex head lock nuts.

Tool: 16mm open-ended wrench

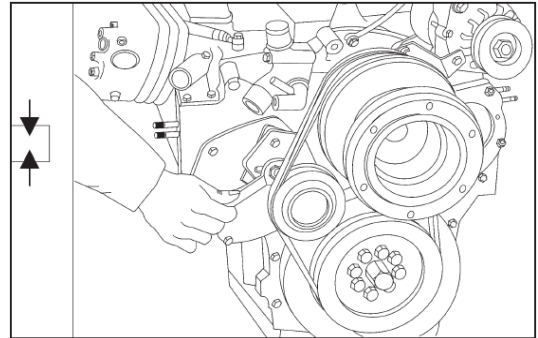

Fuel Supplying System

Replace injection pump

Remove the joint between the high pressure pipe and injection pump.

Tool: 16mm open-ended wrench

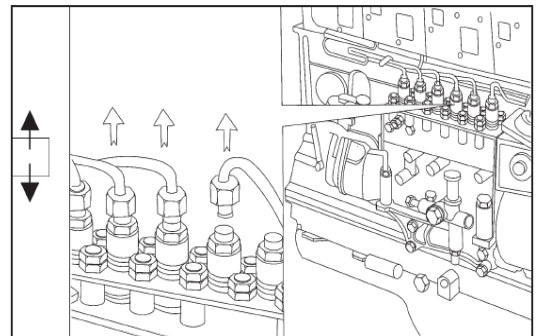

Rotate flywheel slowly, align the calibrating line of flywheel housing to "0T" calibrating line, to fix the position of TDC of compression stroke of the first cylinder.

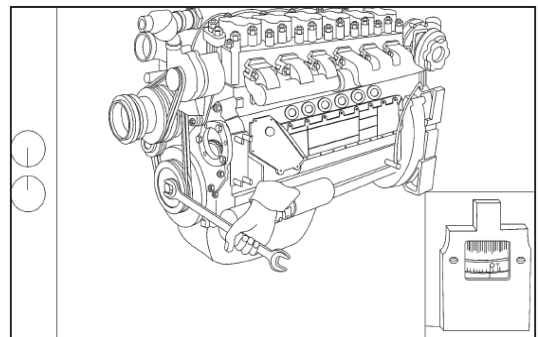

Remove the screws attaching shaft coupling and driving shaft.

Tool: 16mm sleeve wrench

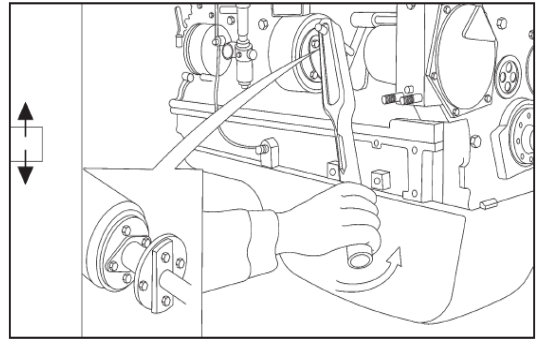

Remove bolts attaching shaft coupling and timing advance unit.

Tool: 16mm open-ended wrench and 16mm double offset ring wrench

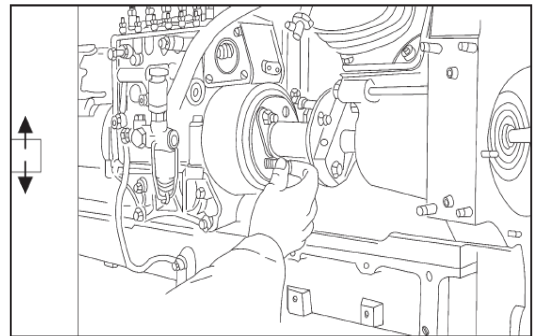

Depart gap of coupling flange attaching the coupling and driving shaft.

Tool: 6# screwdriver 0.5kg

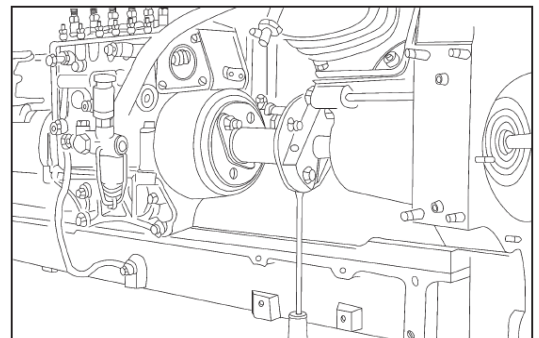

Push shaft coupling backward.

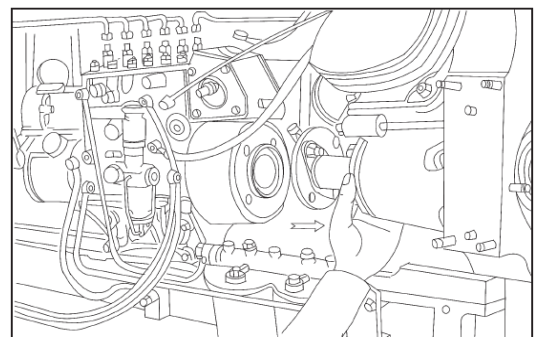

Remove the 4pcs socket head bolts attaching injection pump and bracket

Tool: 8mm inner hexagon wrench

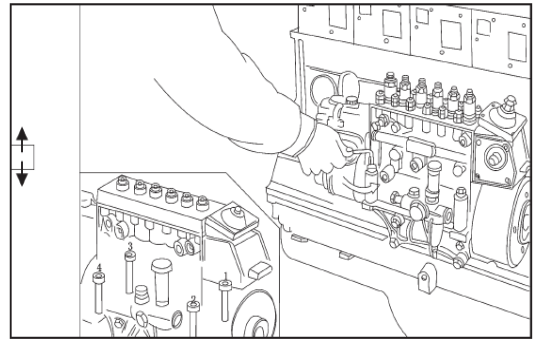

Remove all the connecting pipes from the injection pump.

Tool: 19mm open-ended wrench.

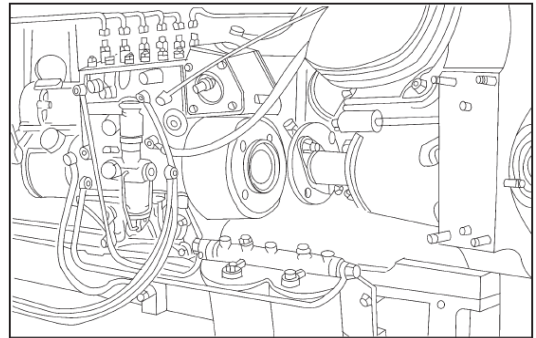

Remove the injection pump and install new injection pump and socket head bolts.

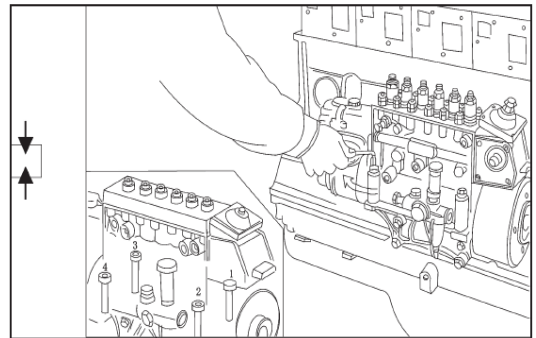

Tighten socket hexagon bolts of injection pump, connect pipeline.

Tightening torque : 45^{+5}_0 N·m

Tool: 8mm sleeve wrench

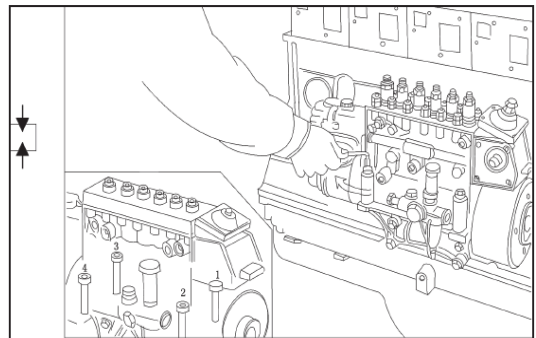

Install bolts attaching injection pump and shaft coupling, coat the thread with LOCTITE 242 THREERADLOCKER before tightening.

Tightening torque: 110N·m.

Tool: 16mm open-ended wrench and 10mm(double offset ring wrench).

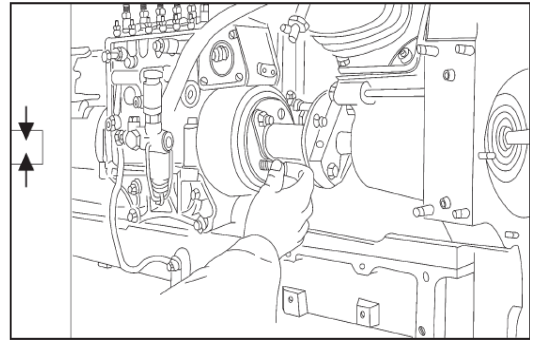

Rotate shaft coupling to watch the fuel oil jiggle at the outlet of any cylinder of the injection pump, then stop rotation.

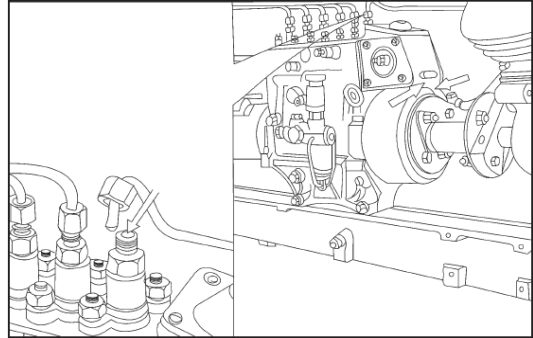

Rotate flywheel to align the indicated needle of flywheel to fuel supply advance angle. (Please refer to Fuel System Mating List for fuel supply advance angle of each cylinder).

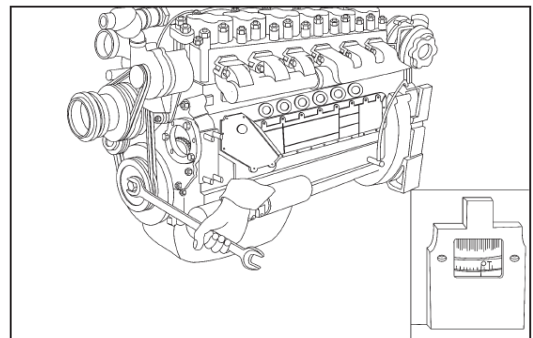

The calibration tails of injection pump is aligned with calibration tails of timing advance unit or flange).

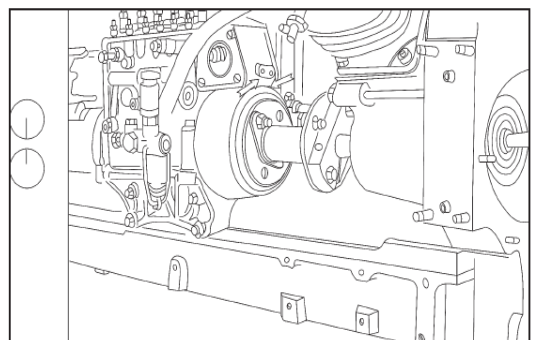

Install bolts attaching shaft coupling and driving haft. Coat the thread with L OCTITE 242 THREADLOCKER before tightening.

Tightening torque: 150_{-5}^{+5} N·m.

Tool: 16mm sleeve wrench

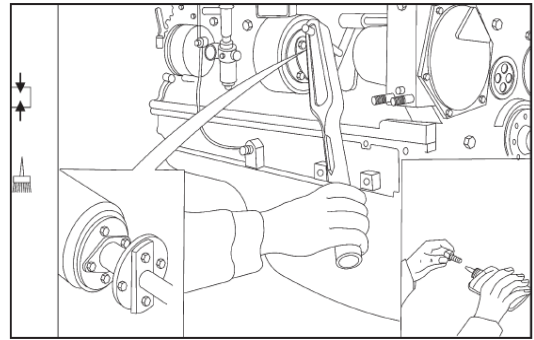

Rotate flywheel to recheck the advance angle of fuel supply, remove bolts attaching shaft coupling and driving shaft for readjustment if necessary.

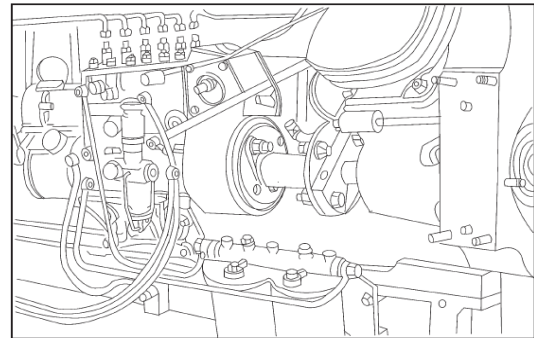

Replace Injection Pump

Clean all round of the injector, remove the joint attaching high pressure fuel pipe and injector.

Tool: 17mm open-ended wrench

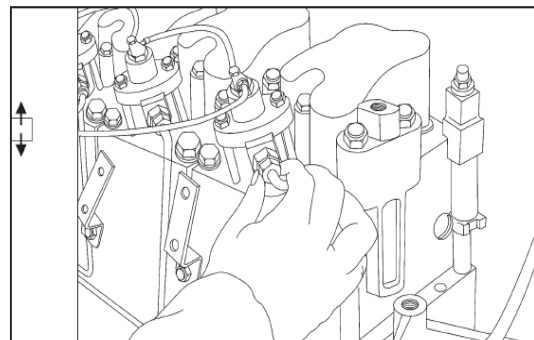

Remove fuel return pipe of the injector.

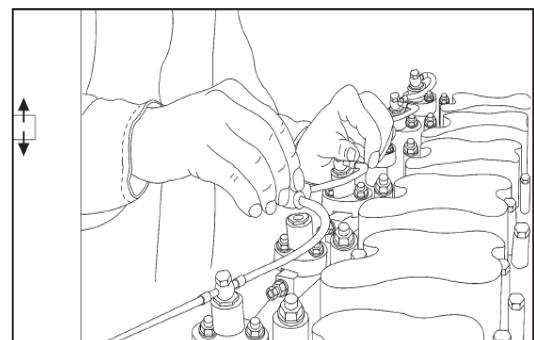

Loosen bolts of mounting plate, then remove mounting plate.

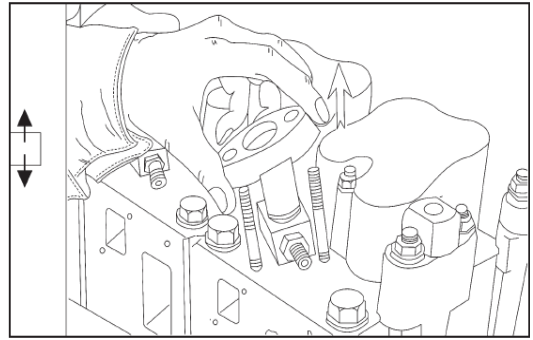

Remove injectors.

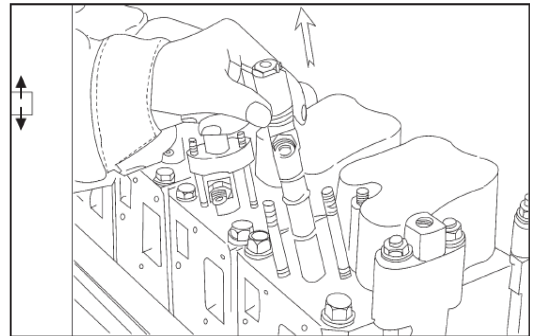

Clean seat hole of injector.

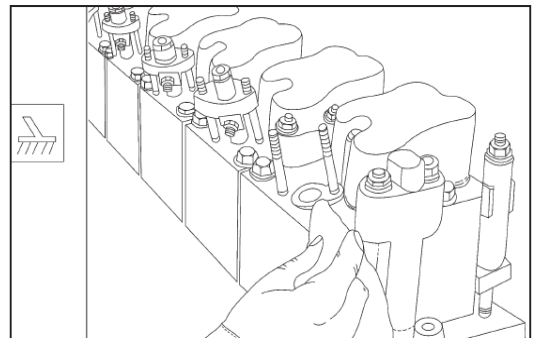

Replace with new copper washer.

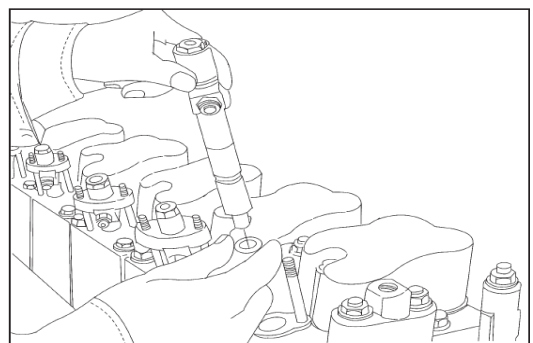

Replace with new injector and install new rubber seal ring.

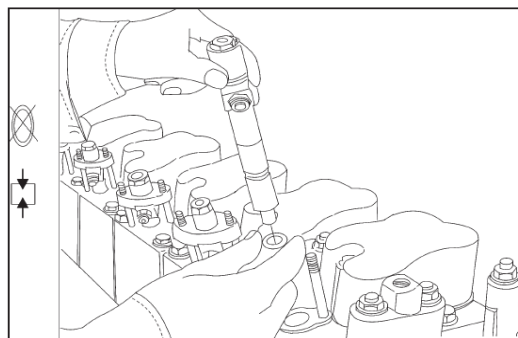

Install new injector into the seat hole.

NOTE: *It is not allowed to appear any mark of pressing rubber cushion after mounting injector .*

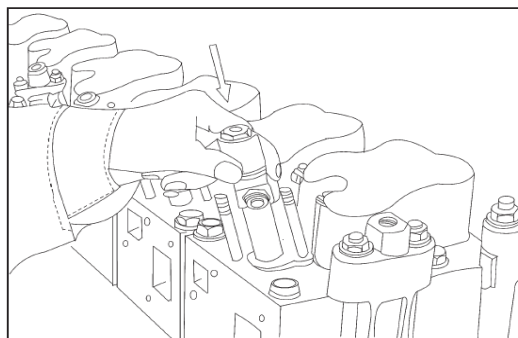

Install the mounting plate of injector.

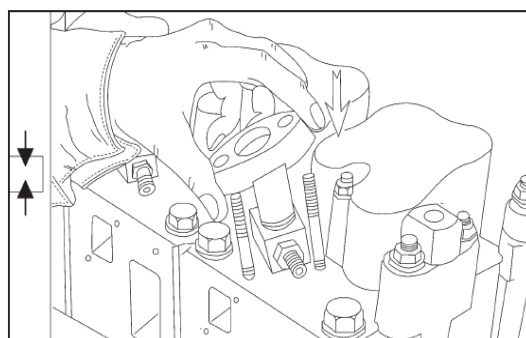

Install bolts or hex head nuts of mounting plate.

Tightening torque : 25N·m

Tool: 13mm sleeve wrench

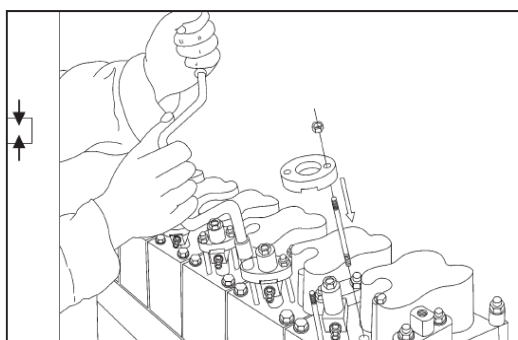

Tighten the joint attaching injector and high pressure fuel pipe, install fuel return pipe.

Tool: 13mm and 17mm open-ended wrench

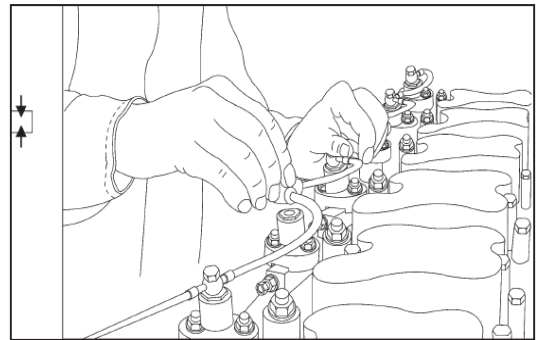

Air Intake System

Replace Turbocharger

Loosen rubber hose clamps from the inlet and outlet of compressor.

Tool: 6mm screwdriver

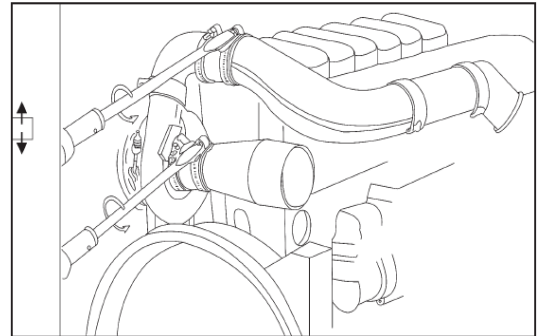

Loosen hose clamp from turbocharger oil return pipe.

Tool: 6mm screwdriver

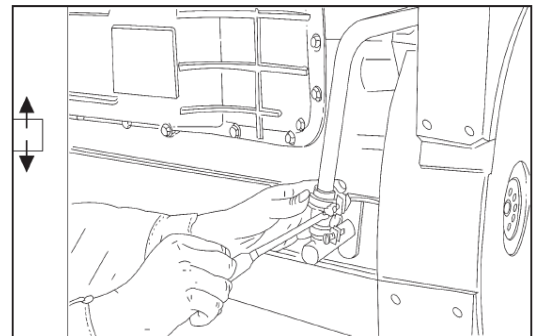

Remove inner head bolts from turbocharger oil inlet sucker, raise flange of sucker.

Tool: 6mm inner hexagon wrench

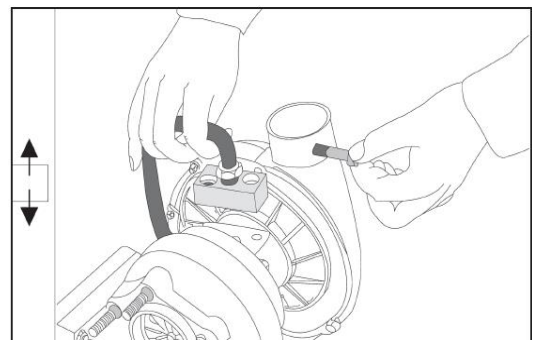

Remove the self-locking nuts from exhaust manifold to remove turbocharger.

Tool: 16mm open-ended wrench

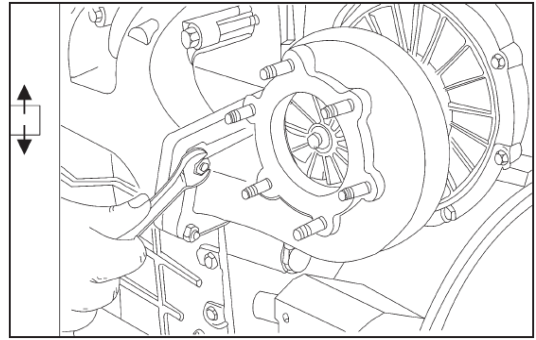

Replace with new turbocharger

NOTE: *If the turbocharger is not replaced immediately, the intake and exhaust manifolds should be covered to prevent anything falling into cylinder.*

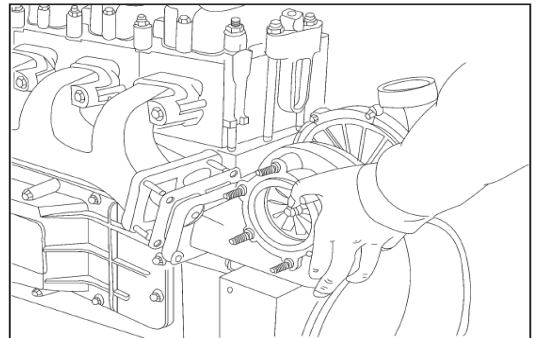

Replace with new gasket for oil return pipe, tighten bolts of oil return pipe.

NOTE: *Make sure to adjust the gasket oil hole and turbocharger flange oil hole, add some clean oil and rotate turbo impeller to let oil flow into bearing case.*

Tool: 6mm inner hexagon wrench

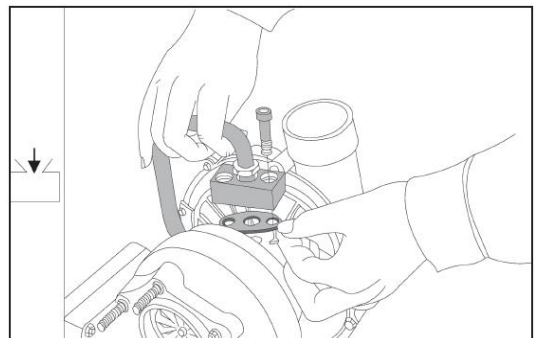

COMMON TROUBLES AND REMEDY

1. Diesel engine can not start

Cause	Remedy
1. Fuel intake filter screen of supply pump or hose clogged	Clear away the dirt and check if the fuel is clean
2. Air entered into the fuel system	Drain off the air, check the sealing of the connector and repair it
3. Injection pump damaged	Check plunger, fuel outlet valve and repair or replace the broken parts
4. Injector damaged	Check the atomization of injector, and repair it
5. Initial angles of valve gear or fuel delivery is wrong	Check and adjust it
6. High pressure line damaged or leaked	Repair or replace
7. Insufficient pressure in cylinder	Check the sealing of the valve and cylinder gasket and the wear of the piston ring. Repair or replace them
8. The temperature is too low	With the addition of start-assist device

2. Stop soon after starting

1. Fuel filter clogged	Dismantle and clean away dirt and water, replace the filter element if necessary
2. Air entered into fuel system	Check fuel pipe and sealing of the connector, tighten air venting bolt, and drain off the air
3. Supply pump doesn't work	Check piston and valve of supply pump, clean and repair
4. Poor quality of fuel	Clean fuel filter and renew fuel
5. Idling speed is too low	Readjust it

3. Insufficient output

1. Air intake clogged (air cleaner choked)	Check the air cleaner and air intake pipe, clean or replace filter element
2. Exhaust back pressure is too high	Check the valve-timing and exhaust pipe, adjust and repair
3. Insufficient pressure in supercharging system	Check and block up the leakage of pipeline
4. Faults in turbocharger	Replace the turbocharger assembly
4.1. Compressor and turbine streets choked up	Clean or replace
4.2. Floating bearing cease to be in effect	Replace
4.3 Carbon deposit or greasy filth in clearance of turbine and compressor back	Clean
5. Intercooler damaged	Replace or repair
6. Leakage or choke of fuel line	Check the sealing of fuel pipe and connector, fuel filter and fuel line, repair, clean or replace the filter element
7. Poor quality of fuel	Clean the fuel tank, filter parts and fuel pipe. Renew the fuel
8. Excessive wear for injection pump or governor	Repair or replace
9. Smoke-limiter diaphragm of injection pump damaged	Repair or replace
10. Air pipe of smoke-limiter damaged	Replace
11. Poor atomizing	Check the injecting pressure, clean away the carbon deposit in nozzle, adjust and repair injector
12. Incorrect timing of valve gear or fuel delivery	Check and adjust it
13. High-speed of governor is adjusted too low	Check the speed-governing and adjust
14. Oil level in the oil sump is too high	Check the oil-dipstick, and drain off unnecessary oil
15. Leakage in cylinder gaskets	Check the compressed pressure at hot state, replace cylinder gaskets
16. Piston ring broken, the clearance of main bearing is too large	Replace worn parts or overhaul the engine
17. Cylinder liner or piston worn, or piston scuffing	Overhaul the engine

4. Fuel consumption is too high

1. Air intake clogged (air cleaner choked)	Check air cleaner and air intake pipe, then clean them
2. Exhaust back pressure is too high	Check exhaust pipe and brake valve, then clean them
3. Poor quality of fuel	Renew the fuel according to requirements
4. Fuel line choked	Check and repair
5. Fuel line leaked	Check and repair
6. Poor atomizing	Check, adjust and repair
7. Incorrect timing of valve gear or fuel delivery	Adjust valve clearance and injection advance angle according to requirements
8. Leakage in cylinder gasket	Check compressed pressure
9. The clearance of main bearing shell is too large Engine need to overhaul	Check and overhaul
10. Piston scuffing	Replace cylinder liner, piston and piston ring
11. Insufficient pressure in supercharging system	Check and block up the leakage of pipeline
12. Faults in turbocharger	Check and replace
13. Intercooler damaged or leaked	Replace or repair

5. Black smoke exhaust

1. Air intake isn't free or exhaust back pressure is too high	Clean
2. Poor quality of fuel	Clean and renew
3. Incorrect timing of valve gear or fuel supply	Adjust according to requirements
4. Poor atomizing	Check, repair or replace injector
5. Excessive injection quantity	Check and adjust (by manufacturer)
6. Insufficient pressure in supercharging system	Check and block up the leakage of pipeline and connector
7. Faults in turbocharger	Check and replace
8. Intercooler damaged or leaked	Replace or repair
9. Incorrect working point of smoke-limiter	Readjust (by manufacturer)

6. Lub-oil gathered in air intake port and air intake pipe of turbocharger

1. The sealing of turbocharger cease to be in effect	Repair or replace turbocharger
2. The gas-oil separator cease to be in effect	Replace
3. Lub-oil level in oil sump is too high	Drain off unnecessary oil according to requirements

7. White, blue smoke exhaust

1. Poor quality of fuel, contains water	Renew fuel
2. Temperature of cooling water is too low	Check working temperature of thermostat, replace if necessary
3. Incorrect timing of valve gear or fuel delivery	Check and adjust
4. Poor atomizing	Check and repair
5. Incomplete combustion, scuffing and the compressed pressure is too low	Check piston ring, cylinder liner, cylinder gasket, and repair them
6. Wear-in between the piston rings and cylinder liners is not good	Go on wearing-in
7. The gaps of the piston rings are not staggered	Adjust, reassembly
8. Piston oil rings cease to be in effect	Replace
9. The fit clearance between piston and cylinder liner is too large	Repair or replace
10. The sealing ring of turbocharger worn	Check and replace
11. The thrust bearing of turbocharger worn	Check and replace
12. The oil return pipe of turbocharger choked.	Clean or repair

8. Uneven engine speed

1. Poor quality of fuel, mingled with water or wax	Clean fuel system, and renew fuel
2. Air entered into fuel suction pipe	Check the sealing of fuel pipe and connector, drain off air
3. Faults in flyweight of governor and speed governing spring	Check and repair (by manufacturer)
4. Uneven fuel delivery	Check and adjust (by manufacturer)
5. Unstable atomizing	Check and repair
6. Surge in turbocharger	Check, Wash compressor streets, clean away the carbon deposit from exhaust passage
7. Bearing of turbocharger damaged	Replace it

9. Cooling water temperature is too high

1. Water level in water tank is too low	Check water leakage, add water
2. Water tank clogged	Clean or repair
3. The belt of water pump loosened	Adjust tension according to requirements
4. Water pump gasket damaged, water pump impeller worn	Check and repair, or replace
5. Faults in thermostat	Replace it
6. Water pipe damaged and air entered	Check the water pipe, connector and gasket. Renew the damaged parts
7. The oil level in oil sump is too low	Check oil leakage, repair and add oil

10. Lub-oil pressure is too low

1. Oil level in oil sump is too low	Check oil leakage, add oil
2. Faults in pressure regulating valve of main oil passage	Check valve, clean and repair
3. Strainer, oil pipes, connector gasket choked or broken	Check strainer and connector , check if there is any sponge in oil passage, repair
4. Lub-oil does not conform to specifications	Renew the lub-oil according to requirements
5. Intake pipe of oil pump leaked	Check the oil pipe and connector, repair or replace
6. Wear-in between the piston rings and cylinder liners is not good	Go on wearing-in
7. The gaps of the piston rings are not staggered	Adjust, reassembly
8. Piston oil rings cease to be in effect	Replace
9. The fit clearance between piston and cylinder liner is too large	Repair or replace
10. The sealing ring of turbocharger worn	Check and replace
11. The thrust bearing of turbocharger worn	Check and replace
12. The oil return pipe of turbocharger choked.	Clean or repair

11. Parts wore quickly

1. Filter element of air cleaner is unqualified or damaged	Check and replace filter element
2. Air leakage in air intake system	Check air intake pipe, gasket and connecting sleeve, repair or replace
3. Oil level in oil sump is too low	Check oil leakage, repair and add oil
4. Oil passage clogged	Clean
5. Oil doesn't conform to specifications	Renew lub-oil according to specifications
6. Piston rings broken or worn	Replace
7. Cylinder liner and piston worn or piston scuffing	Dismantle and check piston and liner, repair or replace
8. Filter element of oil filter can not be replaced in time	Replace it according to specifications
9. Excessive wear of parts, need to over-haul	Check the mileage and overhaul
10. Crankshaft isn't concentric with the shaft of engine follower	Check the mounting support, repair it
11. Wrong oil grade	Adopt correct oil grade

12. Noise is too high

1. Poor quality of fuel	Renew fuel
2. Temp of cooling water is too low	Check thermostat, replace it if necessary
3. Incorrect timing of valve gear or fuel delivery	Check, repair and adjust
4. Poor atomizing	Check, repair and adjust
5. Excessive injection quantity	Check and adjust (by manufacturer)
6. Vibration damper damaged	Check connecting bolt and replace damaged parts
7. Leakage in valve or adjusted unsuitably	Dismantle and check valve, readjust it
8. Excessive gear clearance or tooth broken	Check and replace damaged parts
9. Cylinder liner or piston worn, or piston scuffing	Check and repair, or replace
10. Push rod bended or broken	Replace it
11. Piston rings broken or worn	Check and replace damaged parts
12. Piston rings broken or worn	Check and replace damaged parts
13. Excessive wear in main bearing	Check and replace
14. Excessive thrust clearance of crank-shaft	Replace the thrust ring
15. All main bearings are not concentric	Check and repair
16. Crankshaft isn't concentric with the shaft of engine follower	Check the bolts of support and repair
17. Excessive wear in parts, need to over-haul	Check the mileage and overhaul
18. Surge in turbocharger	Clean compressor streets, and clean away the carbon deposit from exhaust passage
19. Sealing ring of turbocharger sintered	Replace turbocharger assembly
20. Turbocharger bearing damaged, moving parts and fixed parts bumped each other	Replace turbocharger assembly
21. Foreign body entered turbocharger turbine or compressor impeller	Replace turbocharger assembly

13. Starting motor doesn't work

1. Insufficient charging for battery	Check, charge or replace
2. Bad contact in connecting wire	Check up circuit, tighten terminal
3. Fuse broken	Replace
4. Bad contact in brush	Clean brush surface or replace brush
5. Short circuit in starting motor	Check and repair it, or replace the motor assembly

14. Starting motor is powerless

1. Insufficient voltage of battery	Charge or replace
2. Bearing bush worn	Replace bearing assembly
3. Bad contact in brush	Clean brush surface or replace brush
4. Commutator unclean or sintered	Clean away the dirt and furbished using sandpaper, or replace commutator assembly
5. Sealing off at wire end	Re-weld
6. Bad contact for switch	Check and repair
7. Wore clutch slipped	Adjust working moment of clutch or replace

15. Generator doesn't work

1. Wire connecting broken, short circuit, joint loosened	Check the connecting wire of generator or galvanometer repair
2. Coil of rotator and stator shorted, broken	Repair or replace
3. Rectifier tube damaged	Replace
4. Terminal damaged, wire broken	Repair
5. Voltage regulated by regulator is too low	Repair
6. Contact of regulator fused	Repair or replace

16. Insufficient charging of generator

1. Connecting wire broken or shorted, terminal loosened	Repair
2. Coil of rotator and stator shorted or broken partially	Repair or replace
3. Belt of generator loosened	Check and adjust tension
4. Rectifier tube damaged, bad contact in brush	Repair
5. Insufficient voltage of regulator	Regulate
6. Field coil or resistance connecting wire broken	Repair or replace
7. Insufficient electrolyte of battery or battery is too old	Add electrolyte or renew battery

17. Uneven charging current

1. Coil of rotator or stator will short or break	Repair or replace
2. Bad contact in brush	Repair
3. Terminal loosened and bad contact	Repair
4. Voltage regulator damaged	Repair
5. Incorrect regulated voltage	Check and regulate

18. Generator over-charged

1. Shorted in battery	Repair or replace
2. Voltage of regulator is too high	Repair and regulate
3. Bad contact in regulator	Repair
4. Faults in regulator contact, voltage coil or resistance connecting wire broken	Repair or replace

19. Abnormal sound in generator

1. Incorrect mounting for generator	Repair
2. Bearing damaged	Replace
3. Moving parts bumping to fixed parts	Repair or replace
4. Rectifier shorted	Replace
5. Stator coil shorted	Repair or replace

FRONT AXLE

 CAUTION!

Follow all safety recommendations and safe shop practices outlined in the front of this manual or those contained within this section.

Always use tools and equipment that is in good working order.

Use lifting and hoisting equipment capable of safely handling load.

Remember, that ultimately safety is your own personal responsibility.

TABLE OF CONTENTS

Generation Description.....	3
Structure Chart.....	3
Basic Parameters of Drive Axle	3
Internal Structure of Drive Axle	4
Parts List	4
Hub Drive Axle Assembly	5
Drive Axle Brake Assembly	7
Main Drive Assembly	9
Scheduled Maintenance.....	11
Every Month Maintenance	11
Every Half Year Maintenance	11
Every Year Maintenance.....	11
General Disassembly and Reassembly Instructions.....	12
Axle Disassembly	13
Drive axle Disassembly	13
Assembly Dismantling	18
Axle Reassembly	27
Axle Assembly	27
Assembly Parts Assembling	32

GENERAL DESCRIPTION

Structure chart

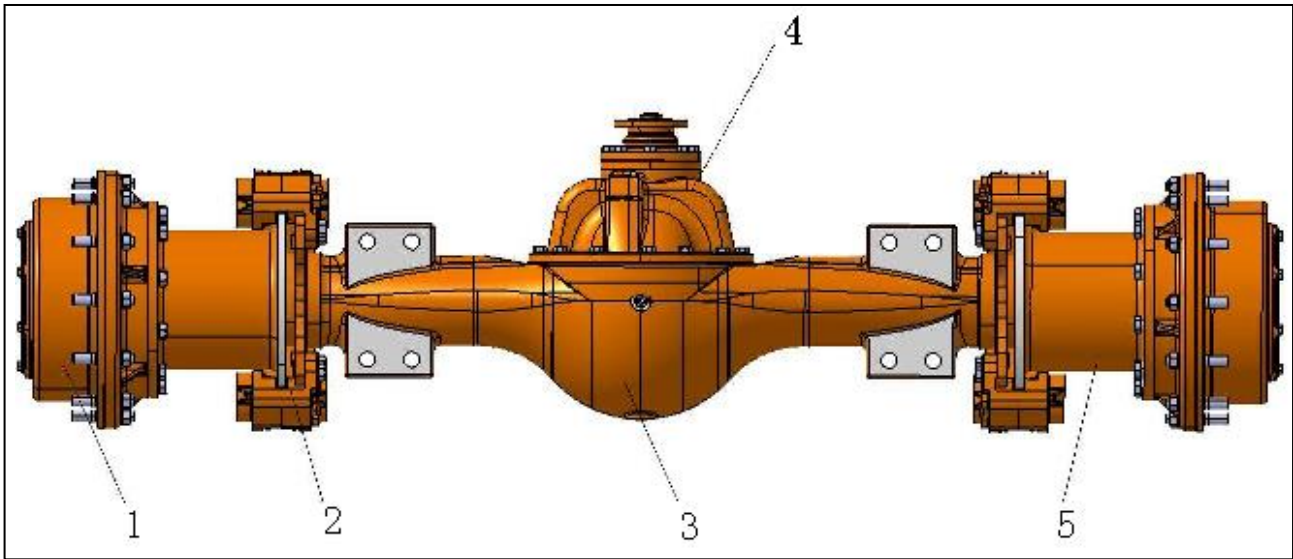

Figure 1

1. EDGE REDUCER ASS'Y 2. BRAKE CLAMP ASS'Y 3. SHELL 4. MAIN REDUCER ASS'Y
5. HUB ASS'Y

Basic parameters of drive axle:

Main drive	Type	Spiral bevel gear grade one reduction
	Reduction ratio	4.625
Hub reduction gear	Type	Grade one planet reduction
	Reduction ratio	4.94
Axle oil	GB13895-1992 gear oil	16Kg

Internal structure of drive axle

Drive axle assembly is one of the most important spare parts of transmission system, its main function is reduce rotation speed from gear box and increase torque, and make wheels at both sides having speed difference. Besides, it also plays the role of bearing and transmitting. Drive axle assembly of loader is mainly composed of shell, main drive (including differential mechanism), semiaxis, hub reduction gear, brake caliper assembly and other parts. Of which, the parts having reduction and differential function is main driver and hub reduction gear; power transmission between main drive and hub reduction gear is realized through semiaxis, multiple spline at both sides of semiaxis and axle shaft gear of differential mechanism and sun gear of hub reduction gear mesh with each other to realize power connection between main drive and hub reduction gear.

PARTS LIST

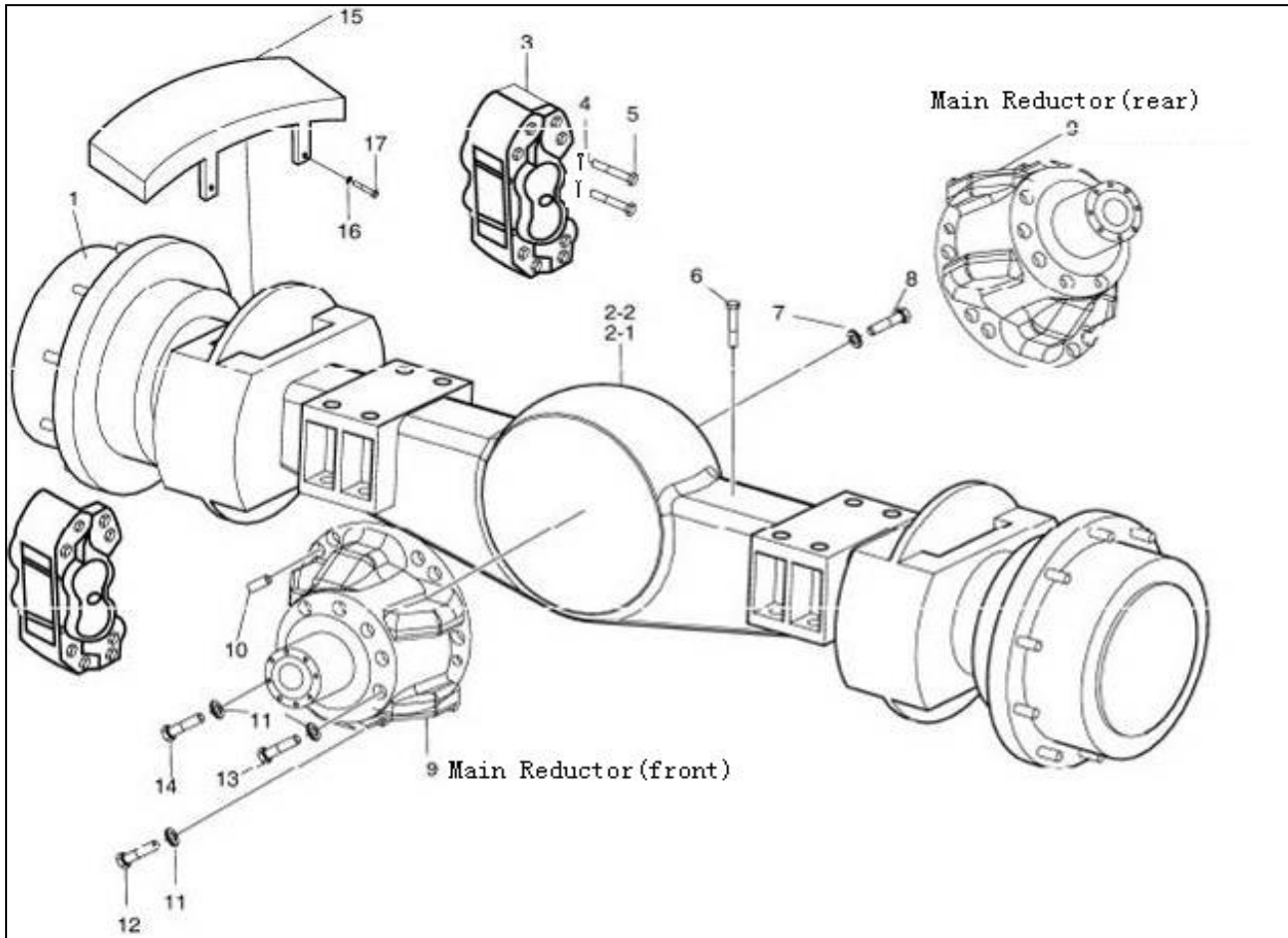

Figure 2

Reference Number	Description	Reference Number	Description
1	REDUCTOR ASS'Y	9	MAIN REDUCTOR (FRONT)
2-1	SUPPORT ASSY,AXLE		MAIN REDUCTOR (REAR)
2-2	REAR DRIVING AXLE SHELLI	10	D12X20 PIN
3	BRAKE ASSY	11	WASHER
4	PIN	12	BOLT M14X1.5X35-10.9
5	BOLT FOR BRAKE	13	BOLT M14X1.5X40-10.9
6	DEFLATION VALVE Z1/8	14	BOLT M14X1.5X60-10.9
7	O-RING25.8X2.65	15	PLATE,COVER
8	PLUG	16	WASHER
		17	BOLT

Hub drive axle assembly

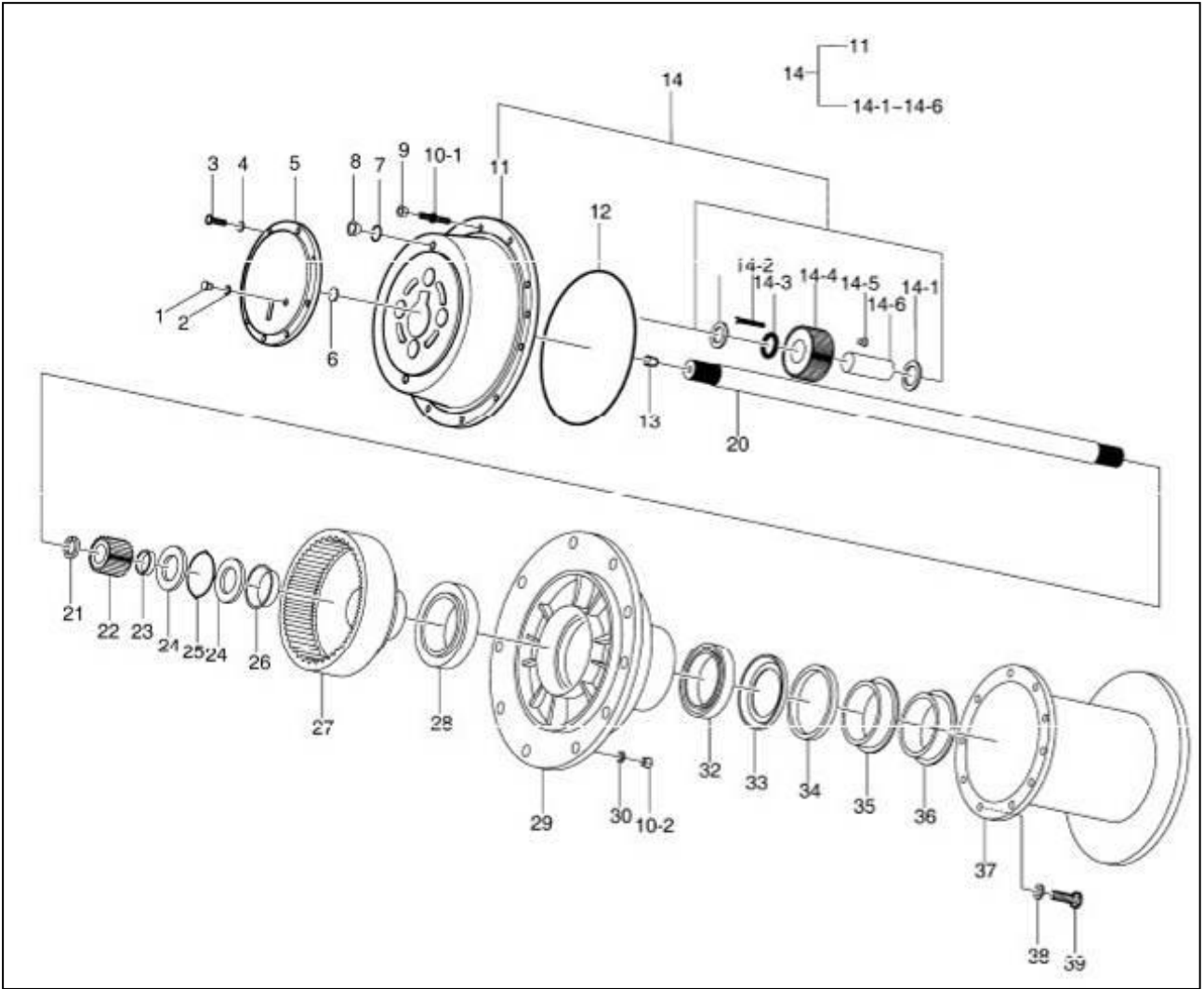

Figure 3

Reference Number	Description	Reference Number	Description
1	PLUG	14-5	STEEL BALL
2	WASHER	14-6	SHAFT OF PLANETARY GEAR
3	BOLT M12X1.25X30	20	SHAFT
4	WASHER	21	SNAP RING
5	COVER	22	SUN GEAR
6	SNAP RING	23	SPACER
7	O-RING25.8X2.65	24	NUT
8	PLUG	25	WASHER FOR NUT
9	NUT,HEX FLANGE	26	TAPER BUSHING
10	BOLT ASSY: WITH NUT	27	INTERNAL GEAR ASSY
10-1	STUD 7/16X4.21	28	32026 BEARING
10-2	NUT	29	RIM,WHEEL
11	CARRIER,PLANETARY GEAR	30	WASHER
12	SEAL RING	32	32024 BEARING
13	ADJUSTING PIN	33	WASHER
14	CARRIER,PLANET	34	RING,SNAP
14-1	WASHER FOR PLANETARY GEAR	36	OIL SEAL
14-2	BEARING,NEEDLE ROLLER	37	BRAKE DISK
14-3	SPACE BUSHING	38	WASHER
14-4	PLANETARY GEAR	39	BOLT
14-5	STEEL BALL		

Drive axle brake assembly

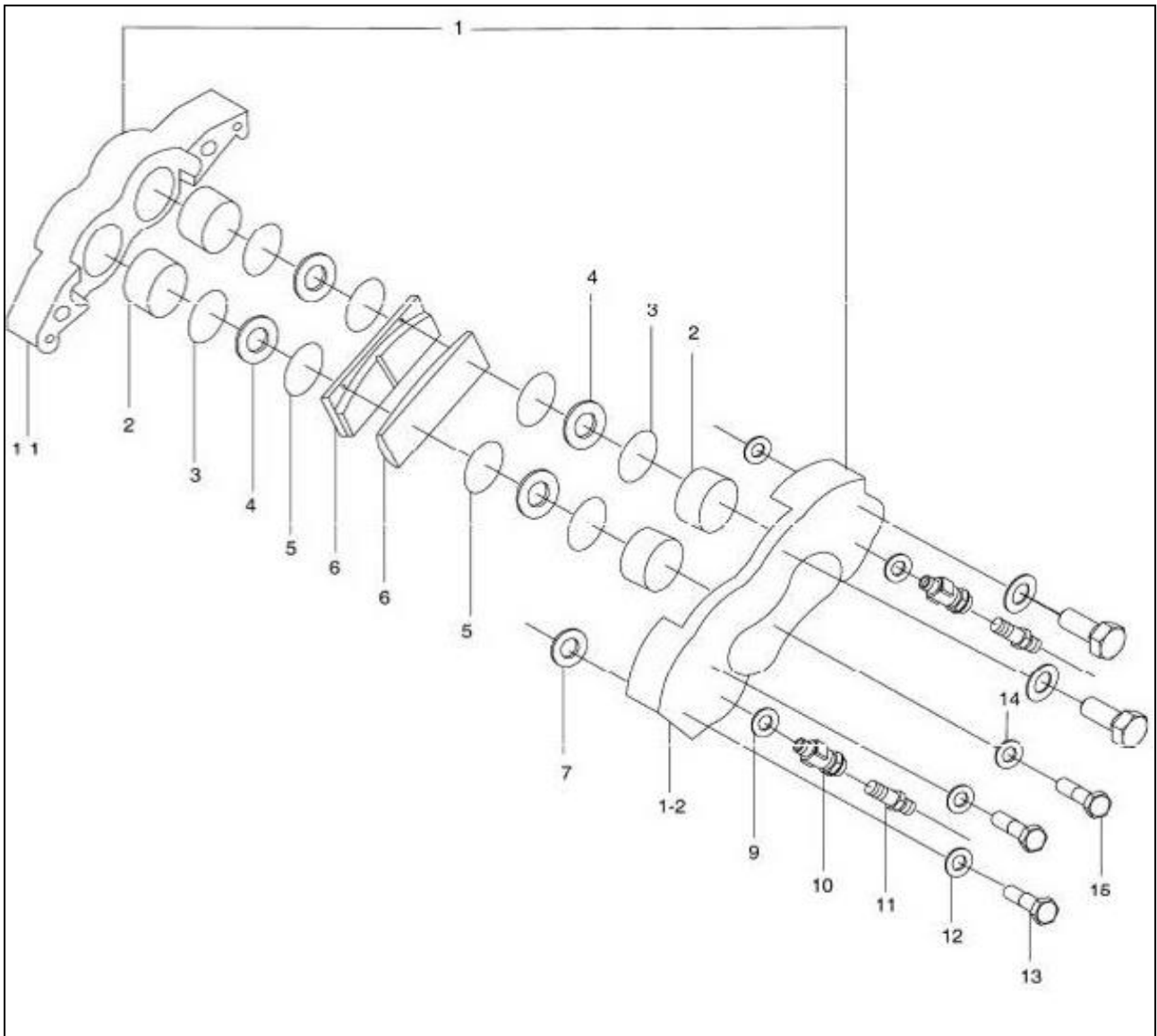

Figure 4

Reference Number	Description	Reference Number	Description
1	CALIPER ASSY	7	O-RING
1-1	EXTERIOR BRAKE	9	WASHER
1-2	INNER BRAKE	10	CONNECTING
2	PISTON	11	DEFLATING VALVE
3	RECTANGULAR SEAL	12	WASHER
4	DUST CASE	13	BOLT
5	BLOCK RING	14	WASHER
6	BRAKE DISK	15	BOLT PIN

Main drive assembly

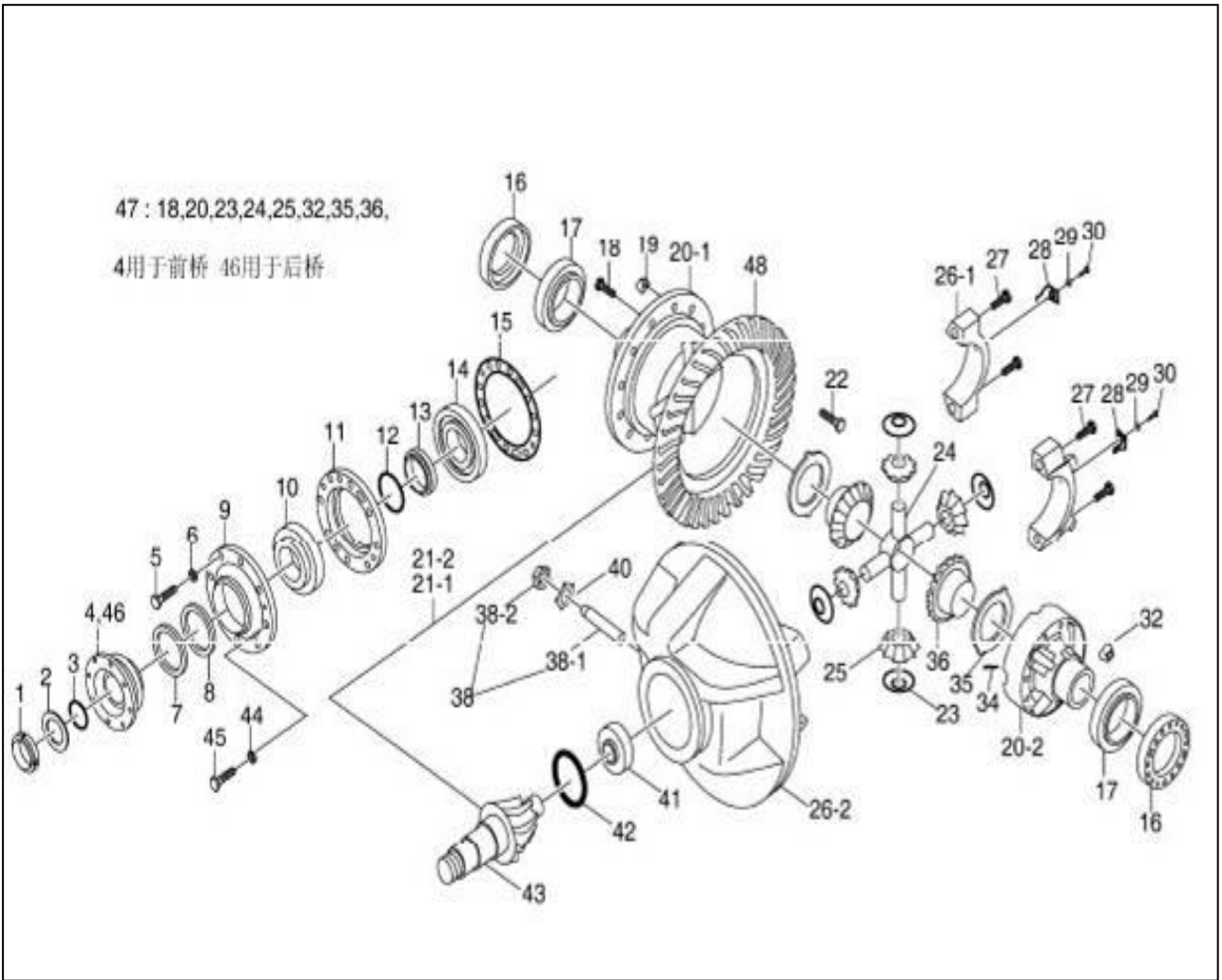

Figure 5

Reference Number	Description	Reference Number	Description
1	LOCK NUT	24	DIFFERENTIAL CROSSING
2	WASHER	25	BEVEL GEAR
3	O SEAL RING	26	CASE,BEARING
4	FLANGE	26-1	BEARING SEAT
5	BOLT	26-2	DIFFERENTIAL CAGE
6	WASHER	27	BOLT FOR MAIN REDUCTOR
7	OIL SEAL	28	LOCK PLATE
8	RING,SHIM	29	WASHER
9	SEALING GLAND	30	BOLT M10X1X20-8.8
10	BEARING	32	M16X1.5NUT
11	BEARING BUSHING	34	DIFFERENTIAL BOLT
12	ADJUSTING WASHER	35	WASHER
13	SHAFT BUSHING	36	AXLE SHAFT GEAR
14	BEARING	38	BOLT,UNION
15	ADJUSTING WASHER	38-1	BOLT
16	ADJUSTING NUT	38-2	NUT M27X2
17	BEARING	40	LOCK PLATE
18	DIFFERENTIAL BOLT	41	BEARING
19	M14X1.5 NUT	42	90/96.5 STOP RING
20	CAGE,DIFFERENTIAL	43	DRIVING BEVEL GEAR
20-1	DIFFERENTIAL CAGE	44	WASHER
20-2	DIFFERENTIAL CAGE	45	BOLT
21-1	DRIVEN BEVEL GEAR	46	FLANGE ASSY
21-2	GEAR ASSY,BEVEL	47	GEAR ASSY,DIFFERENTIAL
22	BOLT	48	DRIVING BEVEL GEAR
23	WASHER FOR BEVEL GEAR	48	DRIVING BEVEL GEAR

SCHEDULED MAINTENANCE

Oil of new drive axle must be replaced after working for 15 days (about 100 working hours), oil shall be replaced once after working for every six months (about 1200 working hours) in following days.

Every month maintenance:

1. Check abrasion condition of brake disc, if there is disruptive abrasion; please handle in time if there is any.
2. Check abrasion condition of brake block to guarantee separation and reunion of brake caliper is flexible; it shall be replaced in time when brake block is wearing close to abrasion line (at the bottom of groove).
3. Check if oil level of shell complies with requirements, please add new oil if the oil level descends.
4. Keep axle clean, keep vent pipe smooth, and avoid silt going into axle. Check loosening condition of all fasteners, especially rim nuts, if it is loosed, please refasten again.

Every half year maintenance:

Lubrication oil in axle shall be replaced every half a year, different brands of lubrication oil shall be adopted for different areas and seasons. Please refer to 4.2 for oil replacing method.

Every year maintenance:

Overhaul checking every working year:

1. Check the gap, mesh and abrasion condition of spiral bevel gear of main reducer.
2. Check abrasion condition of differential mechanism gear.
3. Check abrasion condition of hub gear.
4. Check abrasion condition of needle bearing of hub planetary gear.
5. Requirements of installation and debugging items after overhaul checking:
 - 1) After assembling, axle shaft gear and bevel gear shall move flexibly with hand touching rather than locking. The Min. gear backlash of gear is 0.18-0.23mm. Tooth length and tooth height of contacting area of two gears cannot be less than 50%.
 - 2) In order to guarantee enough bearing rigidity of active spiral gear, before assembling oil seal and sealing cover, adopt gradually reducing spacer shim between two tapered roller bearing to give 1.0-1.5N.m preloaded torque to roller bearing.
 - 3) Gear backlash between the driving and driven spiral bevel gear is 0.25-0.45mm, the changing amount cannot be more than 0.15mm, gear backlash can be realized through adjusting nuts of both sides of differential mechanism and spacer shim of bearing sleeve. Tooth surface contacting area shall guarantee direction of tooth length and tooth height is not less than 50%, contacting position shall be at the middle side of tooth surface and closer to the smaller side.
 - 4) Adjusting of bearing clearance of shell at both sides of drive axle: Fasten adjusting nuts, give 28-38N.m preload to shell roller bearing, and then lock two round nuts with screw fastening

GENERAL DISASSEMBLY AND REASSEMBLY

INSTRUCTIONS

WARNING!

Never use gasoline, solvents, or other flammable fluids to clean components. Only use approved commercial solvents that are nonflammable and nontoxic.

IMPORTANT

Use only **GENUINE DOOSAN SPARE PARTS** to warrant proper operations and prevent interchangeability problems.

GENERAL INSTRUCTIONS

1. Thoroughly clean and dry axle before disassembly.
2. All components should be thoroughly cleaned and dried before reassembly. Dirt, chips, and foreign material may cause failures.
3. All ducts and castings should be thoroughly cleaned and dried to remove dirt, chips, and foreign material to prevent damage after reassembly.
4. Reassembly should be done in a clean shop, and should be as dust free as possible.
5. Make sure tools and equipment are at hand.
6. When reassembling DISD strongly recommends to replace the following parts with new.
 - Seal Rings.
 - O-rings.
 - Gaskets.
 - Threaded rings with notched collar.
 - Any component damaged during disassembly.
7. When mounting heat fitted components, make sure of their proper position and direction of assembly, after they have cooled.
8. To heat bearings, use proper heating plates, piping, or suitable ovens.

NOTE: *Never heat parts by using a torch. Oil bath, heated by a torch, maybe used to warm components.*
9. Lubricate all sections concerned when reassembling shafts, bearings, etc.
10. Lubricate O-rings before installing them in relevant seats to prevent kinking during assembly, such a position would impair proper sealing.
11. Replace gears only in matched sets to make sure of proper tooth mating.

AXLE DISASSEMBLY

Drive axle disassembly

1. Put drive axle on supporting and make sure main driver assembly is upward.



Figure 6

2. Dismantle brake caliper dust cover

Loosen bolts of dust cover with tools of relative specifications (such as sleeve, open end wrench, etc, same as following situation, which will not state again).



Figure 7

3. Dismantle brake caliper assembly

Loosen the connection bolts between brake caliper and brake caliper support, dismantle brake caliper assemble.



Figure 8

4. Release gear oil from

Loosen hub oil releasing drain plug and shell oil releasing drain plug, turn on slowly with hands to avoid oil spilling.

Note: Store gear oil with clean container.



Figure 9

5. Release gear oil from shell

Turn on oil releasing bolts axle end cap to release gear oil.

Note: Store gear oil with clean container.

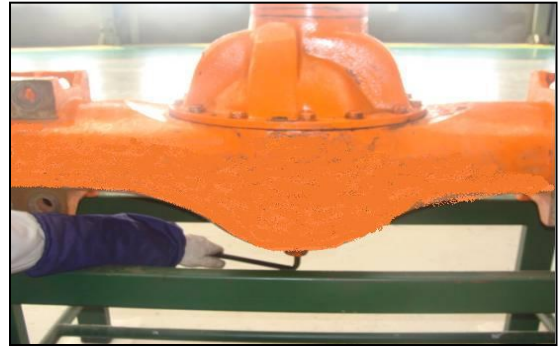

Figure 10

6. Dismantle end cap

Loosen connection bolts between planet carrier and end cap, then get end cap from hub reducer assembly with jackscrew, dismantle end cap.



Figure 11

7. Dismantle locating block

Take down locating block with hands.

Note: If it is tight when taking down, please use assistant tools to pry out.



Figure 12

8. Dismantle stop collar

Dismantle stop collar from semiaxis with stop collar pincers.

Note: Before dismantling stop collar, pull out a section of semiaxis from shell.

Note: It must clamp firmly when using stop collar pincers to avoid safety hazard when it is popup.



Figure 13

9. Dismantle sun gear

Dismantle semiaxis from sun gear.



Figure 14

10. Dismantle locating block

Dismantle locating block from semi axle with hands.



Figure 15

11. Dismantle semiaxis

Take semiaxis from shell slightly.



Figure 16

12. Hub reducer

First loosen rim bolts with relative tools, then loosen rim from planet carrier with jackscrew and dismantle planet carrier assembly.

Note: *Please slowly loosen planet carrier to avoid safety hazard resulted from dropping of planet carrier assembly.*



Figure 17

13. O Ring

Dismantle O ring from hub.

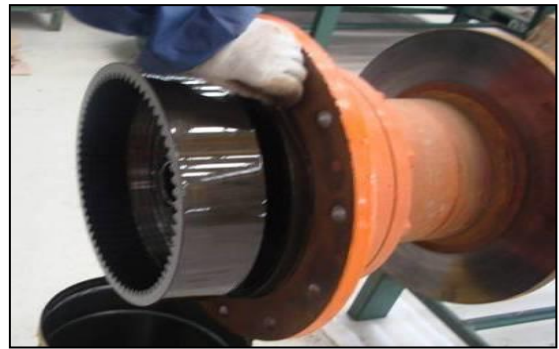

Figure 18

14. Dismantle round bolts

Pry up anti-loosing gasket of round nuts, then
dismantle round nuts.



Figure 19

15. Dismantle internal gear

Take internal gear out by slightly rocking.



Figure 20

16. Dismantle rolling bearing

Take out rolling bearing with special dismantling
tool.



Figure 21

17. Dismantle wheel hub assembly

Take wheel hub assembly from supporting axle.

Note: *During hanging and dismantling process, please keep axis of wheel hub assembly is in line with axis of hub reduction supporting axle to avoid scratching oil surface and internal spare parts during dismantling process.*



Figure 22

18. Dismantle spacer bush

Take out spacer bush.

Remark: Dismantle all parts at the other side with the same method.



Figure 23

19. Dismantle main drive assembly

Dismantle connection bolts between main drive and shell assembly, take out main drive with jackscrew, and suspend main drive assembly.

Note: *When suspending main drive assembly, guarantee suspending and dismantling tools are at the above of main drive assembly to avoid spare parts inside are knocked again during suspending and dismantling process.*



Figure 24

Assembly dismantling

Dismantle planet carrier assembly

1. Put planet carrier on working platform horizontally.



Figure 25

2. Take out planet axle with tools.



Figure 26

3. Take out steel balls.



Figure 27

4. Take out planet wheel.



Figure 28

Front Axle

5. Take out baffle ring and quill roller from inside of planet wheel.



Figure 29

Dismantle hub assembly

1. Put hub assembly on working platform.



Figure 30

2. Loosen connection bolts between brake disc and hub.



Figure 31

3. Take out brake disc.



Figure 32

4. Take out oil seal.



Figure 33

5. Take out baffle ring.

Note: *It must be clamped firmly when using baffle ring pincer to avoid safety hazard when it is popping out during assembling process.*



Figure 34

6. Take out bearing.



Figure 35

Dismantle main drive assembly

1. Put main drive assembly (input flange upward) horizontally and fixed on supporting.



Figure 36

2. Dismantle thrust bolts.



Figure 37

3. Dismantle locknut gasket, O ring and baffle ring.



Figure 38

4. Take out input flange.



Figure 39

5. Dismantle connection bolts between sealing cover and bearing sleeve, take out sealing cover.



Figure 40

6. Turn main drive for 180°,
Dismantle locking wire.

Note: *Some of the machine structure may be different from this figure, please adjust working content according to actual structure.*



Figure 41

7. Dismantle bolts of
Fastening lock plate, take out lock plate.



Figure 42

8. Mark with signs so that they can be back to
original position during assembling.



Figure 43

9. Dismantle connection bolts of bearing seat and
take out bearing seat.



Figure 44

10. Dismantle adjusting nuts.



Figure 45

11. Dismantle bearing outer ring.



Figure 46

12. Hang out differential mechanism assembly.

Note: Keep balance when hanging out to avoid safety hazard.



Figure 47

13. Separate active spiral bevel gear assembly and bracket with jackscrew.



Figure 48

Dismantle differential assembly

1. Put differential assembly vertically on working platform, and guarantee it is stable.



Figure 49

2. Dismantle bearing on left and right shell of differential mechanism.



Figure 50

3. Loosen connection nuts between driven spiral bevel gear and right shell of differential mechanism, dismantle driven spiral bevel gear.

Note: Check or mark sign before dismantling driven spiral bevel gear so that it can be assembled to original position.



Figure 51

4. Loosen connection screws of left and right shell, separate shell of differential mechanism.

Note: Before taking out driven spiral bevel gear, please check or mark assembling sign first so that it can be placed back to the original position.



Figure 52

5. Take out semiaxis gear gasket and semiaxis gear.



Figure 53

6. Take out joint cross and differential gear together, take out differential gear gasket and gear from joint cross.



Figure 54

7. Take out semiaxis gear gasket and gear.



Figure 55

Dismantle active spiral bevel gear assembly

1. Put active spiral bevel gear assembly on working platform, support flange of bearing sleeve, clamp down on thread end of active spiral bevel gear assembly with down device.

Note: *Do not clamp too much to avoid damaging flange, pull out bearing sleeve from active spiral bevel gear assembly.*



Figure 56

2. Reverse bevel gear assembly and take out bearing.



Figure 57

3. Take out bearing sleeve.



Figure 58

4. Take out adjusting gasket.



Figure 59

5. Take out spacer bush.



Figure 60

AXLE REASSEMBLY

Axle assembly

1. Shell

Clean shell and suspend with special supporting.
Fasten gummed plug screw at oil inlet and oil filler.

Note: Plug screw fastening torque: 175 ~ 235 Nm

Note: Loctite 262 taper thread sealant.



Figure 61

2. Spacer bush

Overturn shell and install bearing spacer bush.



Figure 62

3. Wheel hub assembly

Coat lubrication grease on hub supporting axle of shell assembly, assembly wheel hub assembly on both sides of supporting axle of shell assembly.

Note: Grapple the $\Phi 22.5$ hole on wheel hub with push and pull ergometer, pull ergometer along with tangential direction, indication on ergometer is $160 \pm 10N$, if the indication is not within the range of $160 \pm 10N$, adjust tightness degree of round bolts according to the indication until it is within the range of $160 \pm 10N$. In the end, coat Loctite 262 thread fastening sealant for 5~6 from the second thread hole of internal gear (form a liquid level at 1/3 circle of thread), then fasten bolts, and fix round nuts.



Figure 63

Note: Before dynamometry, rotate hub wheel for more than 5 times.

Loctite 262 thread fastening sealant



Figure 64

4. Bearing

Heat the inner ring of rolling bearing to 50°C~80°C and install on inner gear.



Figure 65

5. Internal gear

Assemble internal gear of drive axle at multiple spline at the end of supporting bearing.



Figure 66

6. Round nuts

Assemble round nuts and fasten. Knock internal gear slightly with copper stick to make internal gear in place.



Figure 67

7. Assemble O sealing ring

Assemble O sealing ring on hub assemble.

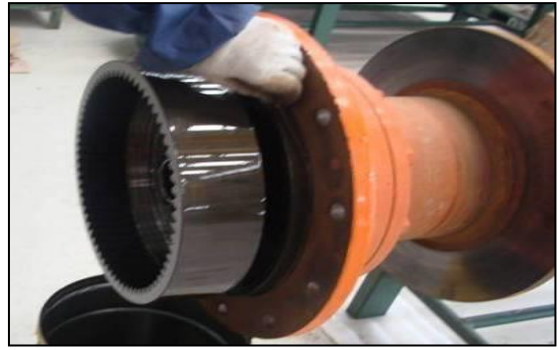

Figure 68

8. Install planet carrier assembly

Assemble planet carrier assembly and O sealing ring on wheel hub with rim bolts, gaskets and nuts.

Note: *fastening torque: 500±10Nm*



Figure 69

9. Assemble semiaxis

Install semiaxis assembly with sun gear on hub (pay attention to semiaxis multiple spline and gear assembly).



Figure 70

10. Assemble sun gear

Assemble sun gear at one side of semiaxis with baffle ring groove

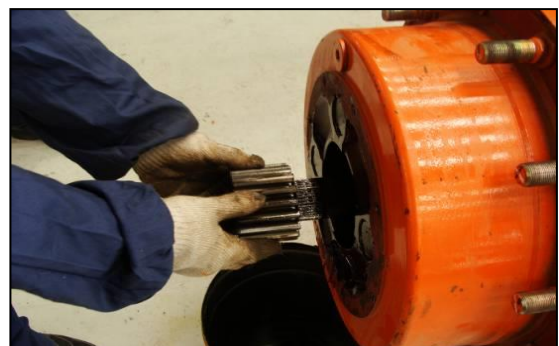

Figure 71

11. Assemble baffle ring

Assemble baffle ring with baffle ring used for axle.

Note: *It must be clamped firmly when using baffle ring pincer to avoid safety hazard when it is popping out during assembling process.*



Figure 72

12. Assemble locating block

Stake steel ball on locating block, it can rotate flexibly after staking steel ball.



Figure 73

13. Assemble end cap

Assemble end cap

Note: *Fasten all screws according to symmetrical and crossing principle. Fastening torque: 110 ~ 130Nm, Loctite 262 thread fastening sealant*



Figure 74

14. Assemble brake caliper assembly

Assemble disc brake on brake caliper supporting, fix with bolts and gaskets.

Note: *Fastening torque: 550±40Nm Coat Loctite 262 thread fastening sealant at 20mm length at thread end during assembling.*



Figure 75

15. Assemble main drive assembly

Coat Loctite 598 silicon rubber surface sealant at the joint surface between shell and bracket, coat $\phi 3 \sim \phi 6$ glue solution ring with sealing surrounding inside of thread hole at the large end of shell. The coated sealant cannot be in the air for more than ten minutes.

Note: *Loctite 598 silicon rubber surface sealant*



Figure 76

16. Assemble main drive

Hand up main drive assembly with overhead crane, put main drive at main drive shell of the axle, assemble locating pin.



Figure 77

17. Assemble bolts

Coat proper Loctite 262 thread fastening sealant on bolts, the coating position is 15mm length at thread end. Fasten main drive assembly and shell assembly with bolts and gaskets.

Note: *Fastening torque: 180 ~ 210Nm*

Loctite 262 thread fastening sealant

Fasten all screws according to symmetrical and crossing principle.



Figure 78

18. Add oil

Add 10L 85W/90 GL-5 gear oil (GB13895-1992) in axle bag of shell and fasten plug screws.

Note: *use 85W/90 GL-5 gear oil*

Anaerobic type pipe thread sealant

Fastening torque: 175 ~ 235 Nm



Figure 79

Inject 4.5L (subject to overflowing from planet carrier) 85W/90 GL-5 gear oil (GB13895-1992) into two hub reducers and fasten plug screws.

Note: 85W/90 GL-5 gear oil

Anaerobic type pipe thread sealant

Fastening torque: 175 ~ 235 Nm



Figure 80

Assembly parts assembling

Install hub assembly

1. Keep the large end of hub upward, assemble bearing outer ring and turn over to keep the small end of hub upward and assemble bearing inner ring.



Figure 81

2. Install baffle ring.



Figure 82

3. Coat lubrication oil at oil seal end, check completeness of oil seal, coat lubrication oil in groove of framework oil seal evenly, and assemble framework oil seal in side of oil seal end cap.



Figure 83

4. Assemble brake disc on hub and fasten with bolts and gaskets.

Note: Fastening torque: $360\pm 20\text{Nm}$

Fasten all screws according to symmetrical and crossing principle.



Figure 84

Assemble planet carrier assembly

1. Stick lubrication grease quill roller (27 units each) on walls of inner holes of planet gears, assemble baffle ring in the middle of quill roller, assemble gaskets at both sides of planet gear, then assemble to the seat hole of planet carrier.



Figure 85

2. Assemble steel balls in holes of planet gear shaft, steel ball shall aim at semi circle of planet carrier, go through the inner hole of planet gear and gasket and assemble on planet carrier. After assembly, planet gear shall rotate flexibly there is no blocking.



Figure 86

Install of main drive assembly

1. Assemble rolling bearing on bear neck of the terminal with pressure machine, rotate to the left on active spiral bevel gear front axle, and rotate to the right side.



Figure 87

2. Press inner ring into rolling bearing with pressure machine at the other side



Figure 88

3. Turn over gear and assemble outer ring of gear



Figure 89

4. Install spacer bush



Figure 90

5. Install gaskets



Figure 91

6. Install bearing sleeve



Figure 92

7. Press inner ring of antifriction bearing in the end.

Note: when assembling main reducer, taper rolling bearing shall have certain tightness that is on the basis of eliminating bearing clearance and give certain preload. The purpose is to reduce axial force caused during transmission process which will result in axial displacement, improve supporting rigidity, and guarantee normal mesh of bevel gear pair. But if it is too tight, it will accelerate abrasion of taper rolling bearing. Press with $P= 5420$ kg pressure at the top side of inner ring of rolling bearing, grapple $\Phi 14.5$ hole with pull and push ergometer, pull ergometer along with tangential direction, indication of ergometer when pushing shall be 17.34-30.06N, if the indication is not within the range of 17.34-30.06N, increase or reduce thickness of spacer shim, repeat the above process until the indication is within 17.34-30.06N.



Figure 93



Figure 94

Assemble of differential assembly

1. Assemble rolling bearing at the bearing position of right shell terminal of differential mechanism.



Figure 95

2. Assemble rolling bearing at the bearing position of left shell terminal of differential mechanism.



Figure 96

3. Assemble semiaxis gear
Assemble semi axis gear gasket in left shell of differential mechanism

Note: *the side of gasket with groove shall toward to the direction of joint cross*



Figure 97

4. Install semiaxis gear



Figure 98

5. Assemble joint cross assembly
Assemble bevel gear (internal of small terminal) and bevel gear gasket on four axles of joint cross.

Note: *Lubricate with grease when assembling bevel gear and bevel gear gasket*



Figure 99

6. Differential mechanism shell

Assemble joint cross in right shell of differential mechanism to make bevel gear and semiaxis gear mesh, turn over left shell assembly of differential mechanism to assemble right shell assembly of differential mechanism, join right shell and left shells of differential mechanism with bolts and fasten with gaskets and nuts.

Note: Nuts fastening torque: 180 ~ 210Nm

Note: Guarantee assembling mark of right shell and left shell of differential mechanism align.

Note: Coat proper Loctite 262 thread fastening sealant at the thread bottom within 12mm length.

Note: After assembling, semiaxis gear and taper gear can be rotated manually without blocking.

7. Install driven spiral bevel gear

Aim at assembling mark, fasten driven spiral bevel gear (Rotate to the left for rear axle, rotate to the right for front axle) with bolts, gaskets and nuts, and fasten screws.

Note: Nuts fastening torque 280 ± 25 Nm.

Note: Coat proper Loctite 262 thread fastening sealant at the thread bottom within 12mm length. **Note:** Judging method of left and right spiral: face to positive side of gear, right rotation refers to the spiral gear rotates to large terminal clockwise; on the contrary, left rotation refers to the spiral gear rotates to large terminal anticlockwise.



Figure 100



Figure 101



Figure 102

Install main reducer

1. Install the assembled active spiral bevel gear assembly in bracket



Figure 103

2. Coat sealant line with diameter 2-4mm at the small end, refer to the picture for sealant line; sealant line and diameter of bearing sleeve (the other side of gasket) shall be done according to the above requirements.

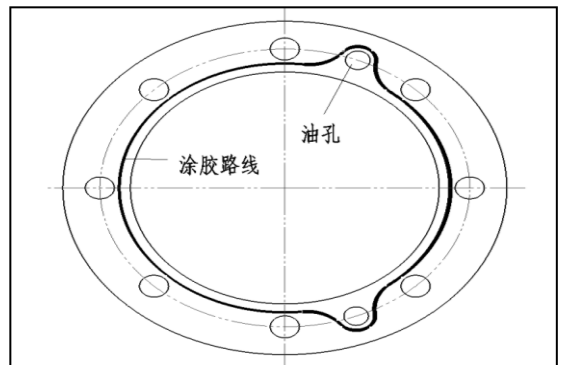

Figure 104

3. Assemble sealing cover
Press oil seal in sealing cover.

Note: Coat a layer of proper lubrication oil when assembling oil seal.



Figure 105

4. Install input flange
Put gasket on the end face of bracket, install sealing cover assembly (coat lubrication grease on oil seal according to common requirements of drive axle), and connect with bracket with bolts and gaskets.

Note: Screw fastening torque 180 ~ 210 Nm



Figure 106

5. Install input flange.



Figure 107

6. Install baffle ring, O ring, coat sealant on one end face of gasket, the surface with sealant is downward, install gasket.

Note: *Loctite 598 sealant*



Figure 108

7. Install gasket



Figure 109

8. Install round screws and fasten.

Note: *Screw fastening torque: 320 ~ 400 Nm*

Note: *Before installing flange, install flange on multiple spline on main spiral bevel gear, measure radial play eccentricity of flange, guarantee it cannot be more than 0.08, and mark matching and assembling signs. If it is out of tolerance, rotate flange to certain angle and measure until it complies with requirements, otherwise, replace flange.*

Note: *Gasket shall be close to $\phi 2 \sim \phi 3$ glue line.*



Figure 110

9. Install differential assembly

Turnover bracket, install differential assembly in bracket.



Figure 111

10. Install bearing seat with gaskets and bolts (bolts shall be a little bit tight). Install adjustable nuts.

Note: Two bearing seats cannot be exchanged.

Note: Coat proper thread sealant on the length of 15~25mm on thread end surface of bolts.



Figure 112

11. Adjust spiral bevel gear

Adjustment of spiral bevel gear mesh condition refers to adjustment of mesh zone and back lash, when adjusting back lash of spiral bevel gear pair, dial gauge can be used to touch the gear surface of large side edge of driven spiral bevel gear, then rotate driven spiral bevel gear to measure back lash directly, the clearance shall be 0.2~0.35mm. Adjusting method of back mesh is



Figure 113

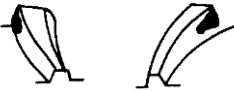
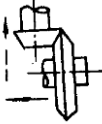
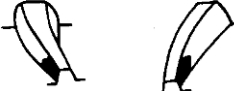
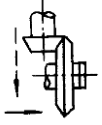
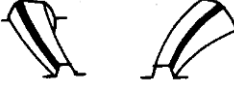
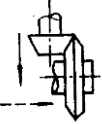
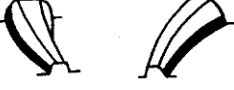



Figure 114

To twist adjusting nuts to change position of driven spiral bevel gear (when it is necessary, move active spiral bevel gear assembly to adjust). If the clearance is larger than the regulated value, approach active spiral bevel gear from driven spiral bevel gear; otherwise be away from it. In order to keep the adjusted preload of taper rolling bearing of differential mechanism, twisting numbers of adjusting nuts at one side shall be equal to twisting numbers of adjusting nuts at the other side.

When adjusting contact zone of spiral bevel gear pair, coat red color (red lead powder) on driven spiral bevel gear teeth (coat three teeth usually), rotate driven spiral bevel gear with hands repeatedly, check contacting moulage. Adjust the correct position of spiral bevel gear mesh moulage: it shall not be less than 50% along with teeth height direction and teeth length direction, mesh moulage of driven bevel gear shall be close to the center, and in the middle of teeth height, smaller than the small end on teeth length direction. Increasing preload of differential bearing: after adjusting back lash of spiral bevel gear well, it shall guarantee the clearance between taper rolling bearing at both sides of differential mechanism is 0. Following is the adjusting methods.

Adjustment of contact zone and back lash when installing spiral bevel gear

Contact zone of driven spiral bevel gear	Adjusting method	Gear moving direction
	Move driven gear to the direction of active gear, if the clearance is too small, move active gear outside	
	Move driven gear away from active gear, if the clearance is too large, move active gear inside	
	Move active gear to the direction of driven gear, if the clearance is too small, move driven gear inside and outside	
	Move active gear away from driven gear, if clearance is too large, move driven gear inside	

Method of adjusting mesh zone is usually increasing and decreasing adjusting gaskets and rotating adjusting nuts. Adjusting of contact zone will affect performance and service life greatly, it shall be carried out carefully.

Note: After adjusting, clean off red lead powder.

12. Install locking plate

Fasten the fixed bolts on bearing seat, fastening torque is 410 ~ 510Nm. Put locking plate at the right position, fix it on bearing seat with bolts and gaskets, and fasten fixing bolts of locking plate.

Note: *Fastening torque 40 ~ 50Nm*

Note: *Coat proper Loctite 262 thread fastening sealant on 5-10mm length at the end surface of fixing bolt.*

Note: *Coat Loctite 262 thread fastening sealant*



Figure 115

13. Install thrust bolts

Overturn carrier, press copper cover into the side with thrust bolts, twist into the center of carrier, make copper contact with the back of driven spiral bevel gear of differential assembly, reverse for 1/6-1/4 circles, fasten with nuts and lock plate.

Note: *Loctite 598 sealant*



Figure 116

14. Bend one of the teeth of lock pate to avoid loosening of nuts.



Figure 117

REAR AXLE

 **CAUTION!**

Follow all safety recommendations and safe shop practices outlined in the front of this manual or those contained within this section.

Always use tools and equipment that is in good working order.

Use lifting and hoisting equipment capable of safely handling load.

Remember, that ultimately safety is your own personal responsibility.

TABLE OF CONTENTS

Generation Description.....	3
Structure Chart.....	3
Basic Parameters of Drive Axle	3
Parts List	4
Assembly	4
Hub Drive Axle Assembly	6
Drive Axle Brake Assembly	8
Main Drive Assembly	10
Scheduled Maintenance.....	12
Every Month Maintenance	12
Every Half Year Maintenance	12
Every Year Maintenance.....	12
General Disassembly and Reassembly Instructions.....	13
Axle Disassembly	14
Drive axle Disassembly	14
Assembly Dismantling	19
Axle Reassembly	28
Axle Assembly	28
Assembly Parts Assembling	33

GENERAL DESCRIPTION

Structure chart

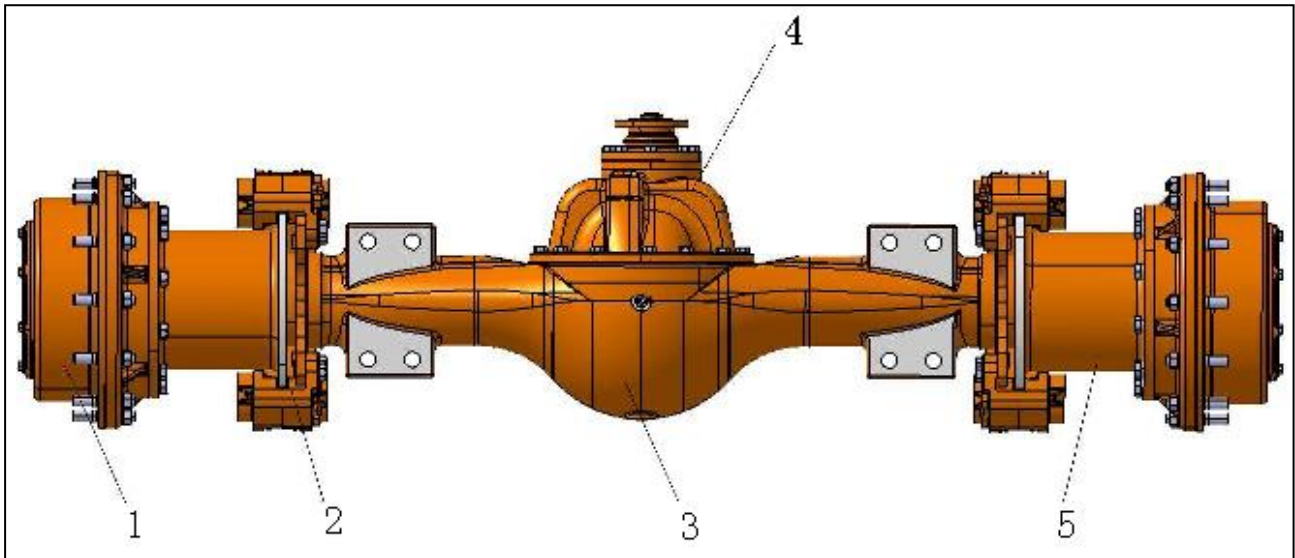

Figure 1

1. EDGE REDUCER ASS'Y 2. BRAKE CLAMP ASS'Y 3. SHELL 4. MAIN REDUCER ASS'Y
5. HUB ASS'Y

Basic parameters of drive axle:

Main drive	Type	Spiral bevel gear grade one reduction
	Reduction ratio	4.625
Hub reduction gear	Type	Grade one planet reduction
	Reduction ratio	4.94
Axle oil	GB13895-1992gear oil	16Kg

Drive axle assembly is one of the most important spare parts of transmission system, its main function is reduce rotation speed from gear box and increase torque, and make wheels at both sides having speed difference. Besides, it also plays the role of bearing and transmitting. Drive axle assembly of loader is mainly composed of shell, main drive (including differential mechanism), semi-axis, hub reduction gear, brake caliper assembly and other parts. Of which, the parts having reduction and differential function is main driver and hub reduction gear; power transmission between main drive and hub reduction gear is realized through semi-axis, multiple spline at both sides of semi-axis and axle shaft gear of differential mechanism and sun gear of hub reduction gear mesh with each other to realize power connection between main drive and hub reduction gear.

PARTS LIST

Assembly

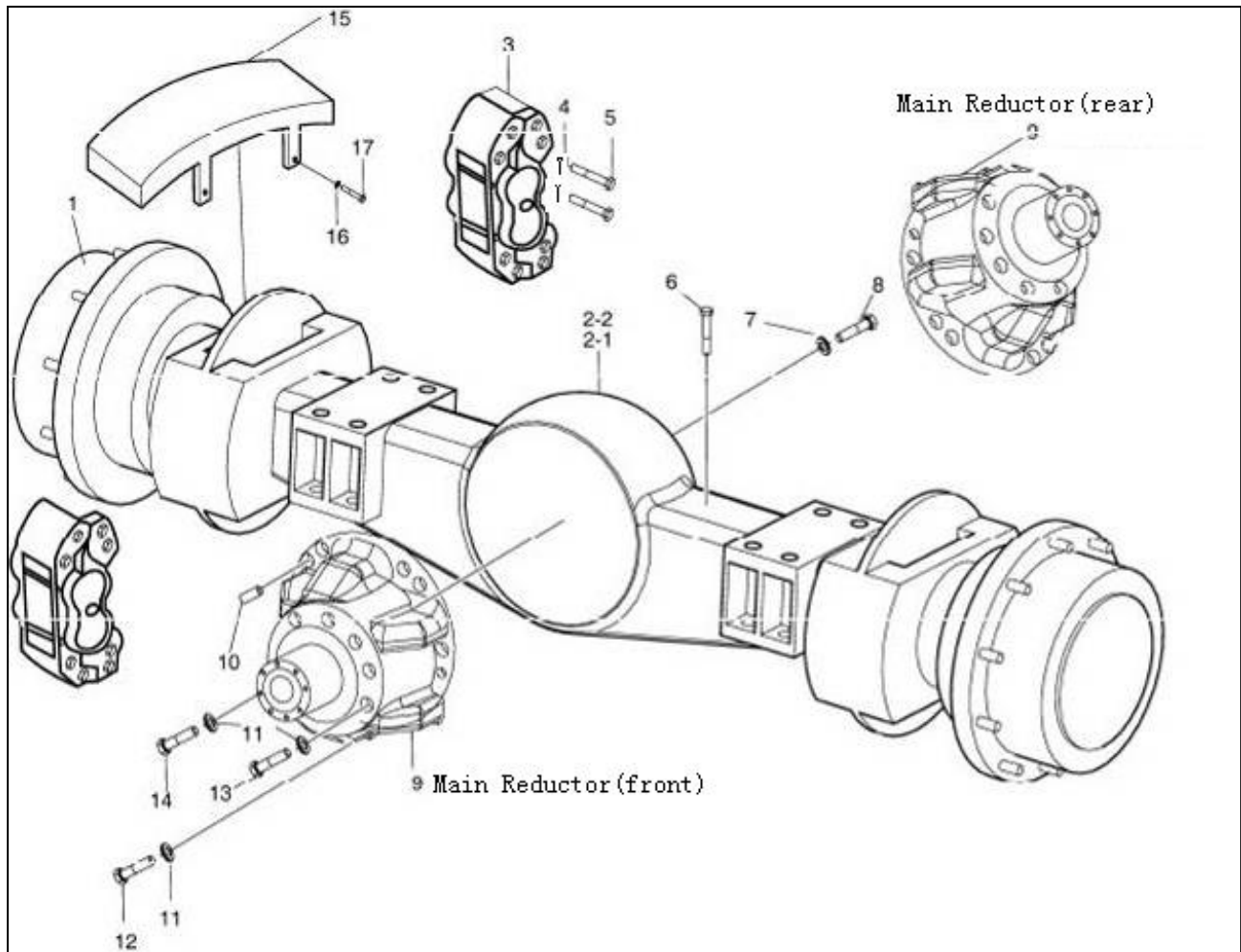

Figure 2

Reference Number	Description	Reference Number	Description
1	REDUCTOR ASS'Y	9	MAIN REDUCTOR (FRONT)
2-1	SUPPORT ASSY,AXLE		MAIN REDUCTOR (REAR)
2-2	Rear driving axle shell	10	D12X20 PIN
3	BRAKE ASSY	11	WASHER
4	PIN	12	BOLT M14X1.5X35-10.9
5	BOLT FOR BRAKE	13	BOLT M14X1.5X40-10.9
6	DEFLATION VALVE Z1/8	14	BOLT M14X1.5X60-10.9
7	O-RING25.8X2.65	15	PLATE,COVER
8	PLUG	16	WASHER
		17	BOLT

Hub drive axle assembly

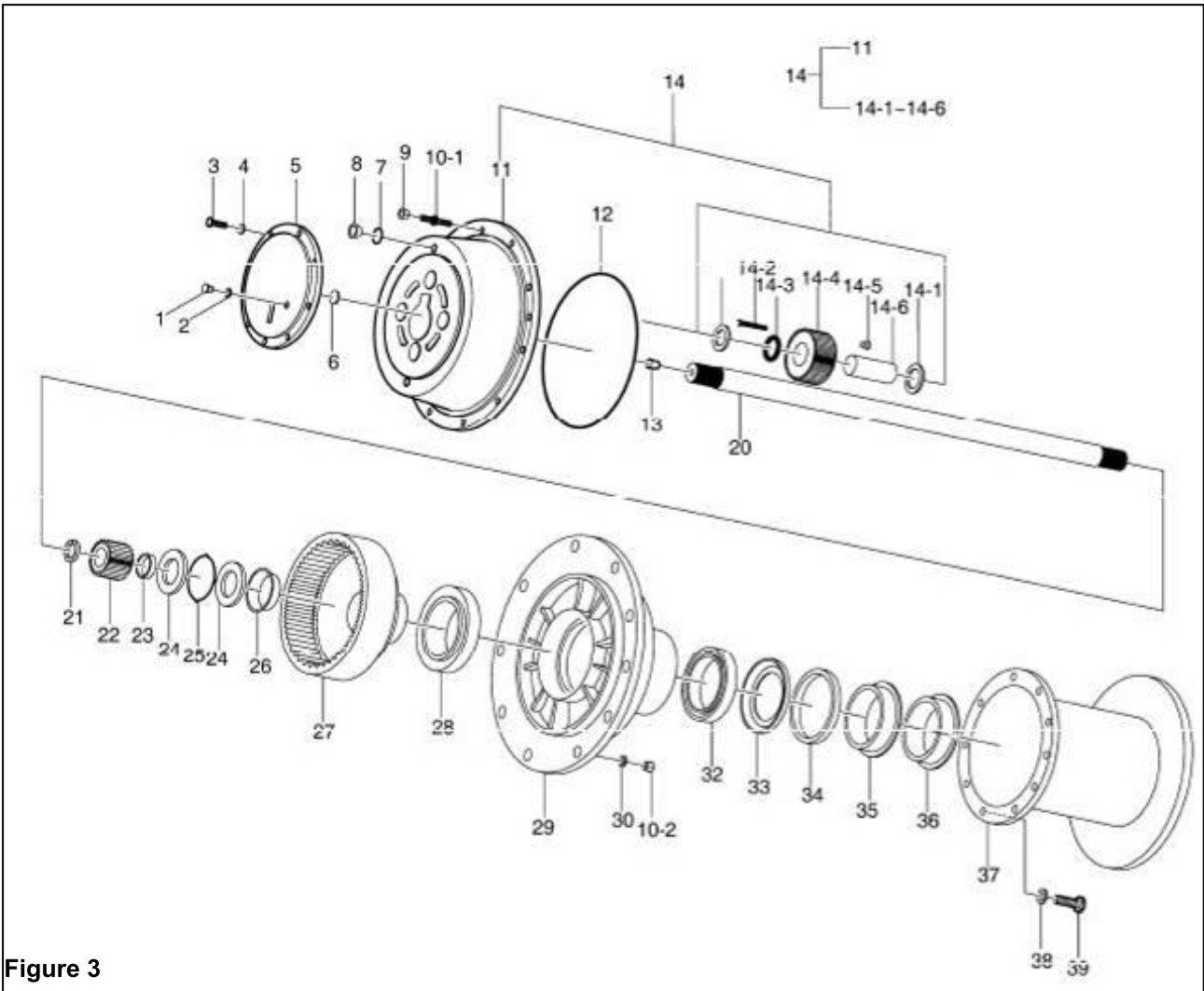

Figure 3

Reference	Description	Reference	Description
-----------	-------------	-----------	-------------

Number		Number	
1	PLUG	14-5	STEEL BALL
2	WASHER	14-6	SHAFT OF PLANETARY GEAR
3	BOLT M12X1.25X30	20	SHAFT
4	WASHER	21	SNAP RING
5	COVER	22	SUN GEAR
6	SNAP RING	23	SPACER
7	O-RING25.8X2.65	24	NUT
8	PLUG	25	WASHER FOR NUT
9	NUT,HEX FLANGE	26	TAPER BUSHING
10	BOLT ASSY: WITH NUT	27	INTERNAL GEAR ASSY
10-1	STUD 7/16X4.21	28	32026 BEARING
10-2	NUT	29	RIM,WHEEL
11	CARRIER,PLANETARY GEAR	30	WASHER
12	SEAL RING	32	32024 BEARING
13	ADJUSTING PIN	33	WASHER
14	CARRIER,PLANET	34	RING,SNAP
14-1	WASHER FOR PLANETARY GEAR	36	OIL SEAL
14-2	BEARING,NEEDLE ROLLER	37	BRAKE DISK
14-3	SPACE BUSHING	38	WASHER
14-4	PLANETARY GEAR	39	BOLT
14-5	STEEL BALL		

Drive axle brake assembly

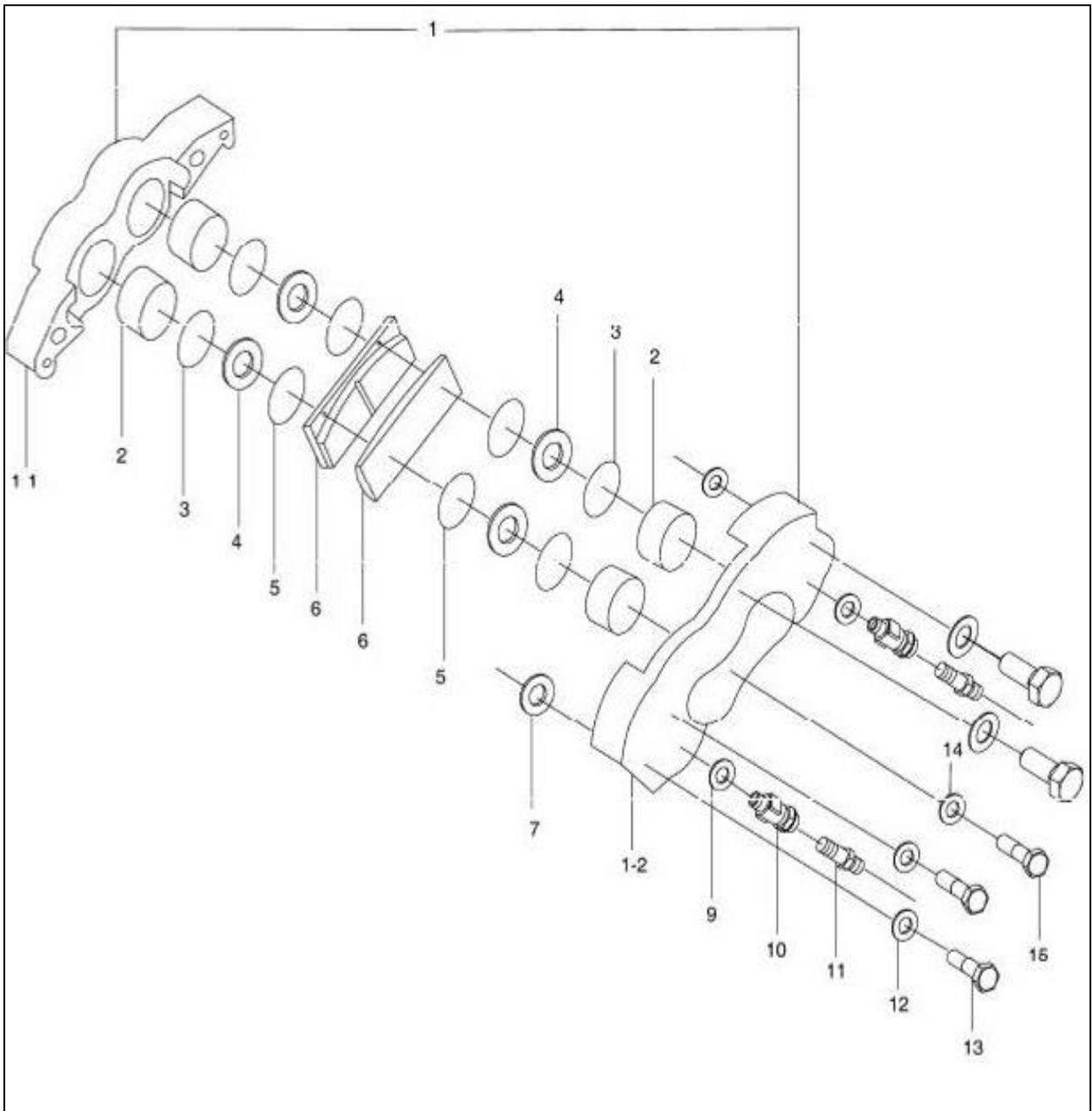

Figure 4

Reference Number	Description	Reference Number	Description
1	CALIPER ASSY	7	O-RING
1-1	EXTERIOR BRAKE	9	WASHER
1-2	INNER BRAKE	10	CONNECTING
2	PISTON	11	DEFLATING VALVE
3	RECTANGULAR SEAL	12	WASHER
4	DUST CASE	13	BOLT
5	BLOCK RING	14	WASHER
6	BRAKE DISK	15	BOLT PIN

Main drive assembly

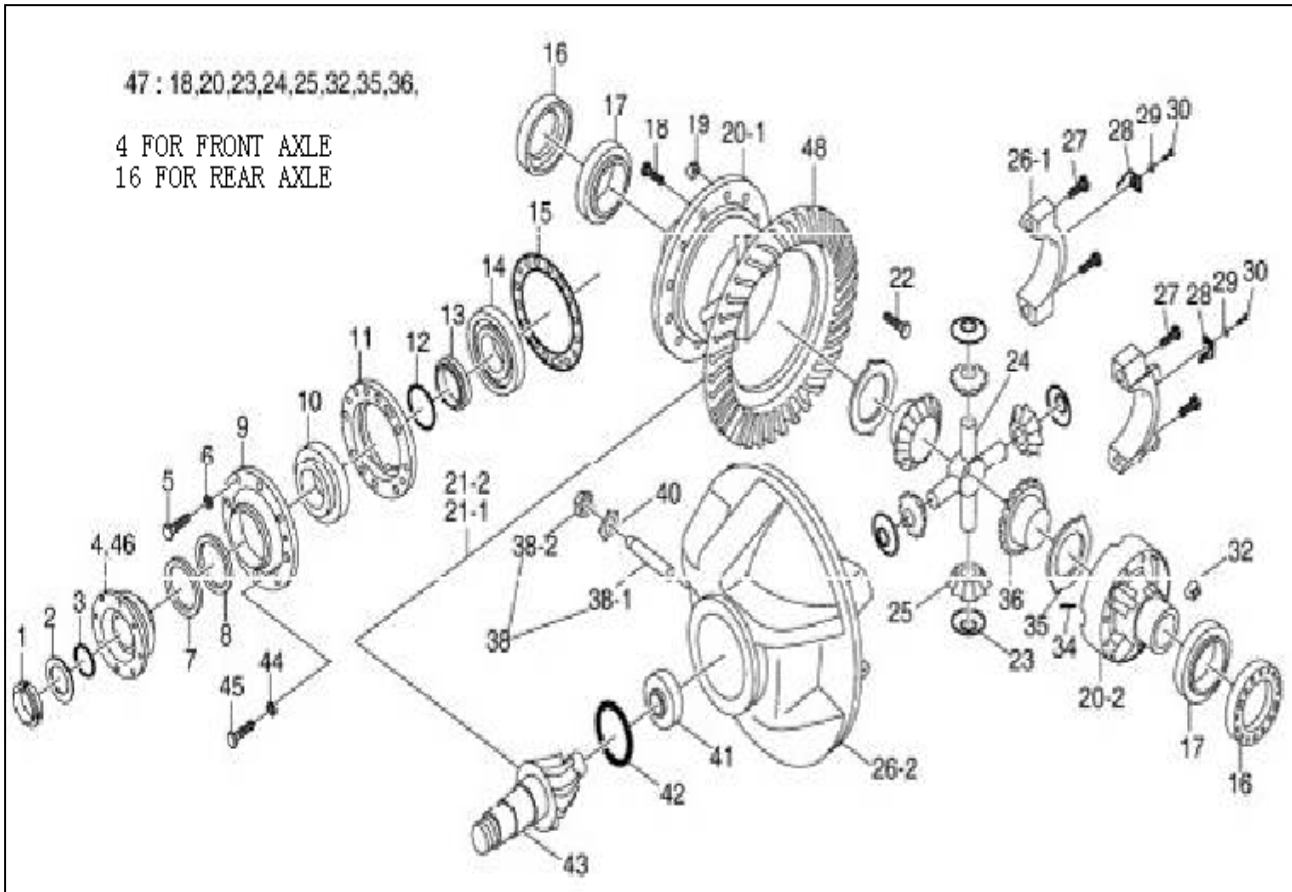

Figure 5

Reference Number	Description	Reference Number	Description
1	LOCK NUT	24	DIFFERENTIAL CROSSING
2	WASHER	25	BEVEL GEAR
3	O SEAL RING	26	CASE,BEARING
4	FLANGE	26-1	BEARING SEAT
5	BOLT	26-2	DIFFERENTIAL CAGE
6	WASHER	27	BOLT FOR MAIN REDUCTOR
7	OIL SEAL	28	LOCK PLATE
8	RING,SHIM	29	WASHER
9	SEALING GLAND	30	BOLT M10X1X20-8.8
10	BEARING	32	M16X1.5NUT
11	BEARING BUSHING	34	DIFFERENTIAL BOLT
12	ADJUSTING WASHER	35	WASHER
13	SHAFT BUSHING	36	AXLE SHAFT GEAR
14	BEARING	38	BOLT,UNION
15	ADJUSTING WASHER	38-1	BOLT
16	ADJUSTING NUT	38-2	NUT M27X2
17	BEARING	40	LOCK PLATE
18	DIFFERENTIAL BOLT	41	BEARING
19	M14X1.5 NUT	42	90/96.5 STOP RING
20	CAGE,DIFFERENTIAL	43	DRIVING BEVEL GEAR
20-1	DIFFERENTIAL CAGE	44	WASHER
20-2	DIFFERENTIAL CAGE	45	BOLT
21-1	DRIVEN BEVEL GEAR	46	FLANGE ASSY
21-2	GEAR ASSY,BEVEL	47	GEAR ASSY,DIFFERENTIAL
22	BOLT	48	DRIVING BEVEL GEAR
23	WASHER FOR BEVEL GEAR	48	DRIVING BEVEL GEAR

SCHEDULED MAINTENANCE

Oil of new drive axle must be replaced after working for 15 days (about 100 working hours), oil shall be replaced once after working for every six months (about 1200 working hours) in following days.

Every month maintenance:

1. Check abrasion condition of brake disc, if there is disruptive abrasion; please handle in time if there is any.
2. Check abrasion condition of brake block to guarantee separation and reunion of brake caliper is flexible; it shall be replaced in time when brake block is wearing close to abrasion line (at the bottom of groove).
3. Check if oil level of shell complies with requirements, please add new oil if the oil level descends.
4. Keep axle clean, keep vent pipe smooth, avoid silt going into axle. Check loosening condition of all fasteners, especially rim nuts, if it is loosed, please refasten again.

Every half year maintenance:

Lubrication oil in axle shall be replaced every half a year, different brands of lubrication oil shall be adopted for different areas and seasons. Please refer to 4.2 for oil replacing method.

Every year maintenance:

Overhaul checking every working year:

1. Check the gap, mesh and abrasion condition of spiral bevel gear of main reducer.
2. Check abrasion condition of differential mechanism gear.
3. Check abrasion condition of hub gear.
4. Check abrasion condition of needle bearing of hub planetary gear.
5. Requirements of installation and debugging items after overhaul checking:
 - 1) After assembling, axle shaft gear and bevel gear shall move flexibly with hand touching rather than locking. The Min. gear backlash of gear is 0.18-0.23mm. Tooth length and tooth height of contacting area of two gears cannot be less than 50%.
 - 2) In order to guarantee enough bearing rigidity of active spiral gear, before assembling oil seal and sealing cover, adopt gradually reducing spacer shim between two tapered roller bearing to give 1.0-1.5N.m preloaded torque to roller bearing.
 - 3) Gear backlash between the driving and driven spiral bevel gear is 0.25-0.45mm, the changing amount cannot be more than 0.15mm, gear backlash can be realized through adjusting nuts of both sides of differential mechanism and spacer shim of bearing sleeve. Tooth surface contacting area shall guarantee direction of tooth length and tooth height is not less than 50%, contacting position shall be at the middle side of tooth surface and closer to the smaller side.
 - 4) Adjusting of bearing clearance of shell at both sides of drive axle: Fasten adjusting nuts, give 28-38N.m preload to shell roller bearing, then lock two round nuts with screw fastening

GENERAL DISASSEMBLY AND REASSEMBLY INSTRUCTIONS

WARNING!

Never use gasoline, solvents, or other flammable fluids to clean components. Only use approved commercial solvents that are nonflammable and nontoxic.

IMPORTANT

Use only **GENUINE DOOSAN SPARE PARTS** to warrant proper operations and prevent interchangeability problems.

GENERAL INSTRUCTIONS

1. Thoroughly clean and dry axle before disassembly.
2. All components should be thoroughly cleaned and dried before reassembly. Dirt, chips, and foreign material may cause failures.
3. All ducts and castings should be thoroughly cleaned and dried to remove dirt, chips, and foreign material to prevent damage after reassembly.
4. Reassembly should be done in a clean shop, and should be as dust free as possible.
5. Make sure tools and equipment are at hand.
6. When reassembling DISD strongly recommends to replace the following parts with new.
 - Seal Rings.
 - O-rings.
 - Gaskets.
 - Threaded rings with notched collar.
 - Any component damaged during disassembly.
7. When mounting heat fitted components, make sure of their proper position and direction of assembly, after they have cooled.
8. To heat bearings, use proper heating plates, piping, or suitable ovens.

NOTE: *Never heat parts by using a torch. Oil bath, heated by a torch, maybe used to warm components.*
9. Lubricate all sections concerned when reassembling shafts, bearings, etc.
10. Lubricate O-rings before installing them in relevant seats to prevent kinking during assembly, such a position would impair proper sealing.
11. Replace gears only in matched sets to make sure of proper tooth mating.

AXLE DISASSEMBLY

Drive axle disassembly

1. Put drive axle on supporting and make sure main driver assembly is upward.



Figure 6

2. Dismantle brake caliper dust cover

Loosen bolts of dust cover with tools of relative specifications (such as sleeve, open end wrench, etc, same as following situation, which will not state again).



Figure 7

3. Dismantle brake caliper assembly

Loosen the connection bolts between brake caliper and brake caliper support, dismantle brake caliper assemble.



Figure 8

4. Release gear oil from planet carrier

Loosen hub oil releasing drain plug and shell oil releasing drain plug, turn on slowly with hands to avoid oil spilling.

Note: Store gear oil with clean container.



Figure 9

Rear Axle

5. Release gear oil from shell

Turn on oil releasing bolts axle end cap to release gear oil.

Note: Store gear oil with clean container.

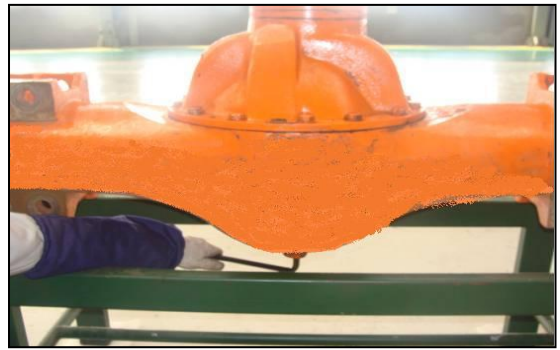

Figure 10

6. Dismantle end cap

Loosen connection bolts between planet carrier and end cap, then get end cap from hub reducer assembly with jackscrew, dismantle end cap.



Figure 11

7. Dismantle locating block

Take down locating block with hands.

Note: If it is tight when taking down, please use assistant tools to pry out.



Figure 12

8. Dismantle stop collar

Dismantle stop collar from semiaxis with stop collar pincers.

Note: Before dismantling stop collar, pull out a section of semiaxis from shell.

Note: It must clamp firmly when using stop collar pincers to avoid safety hazard when it is popping up.



Figure 13

9. Dismantle sun gear

Dismantle semiaxis from sun gear.

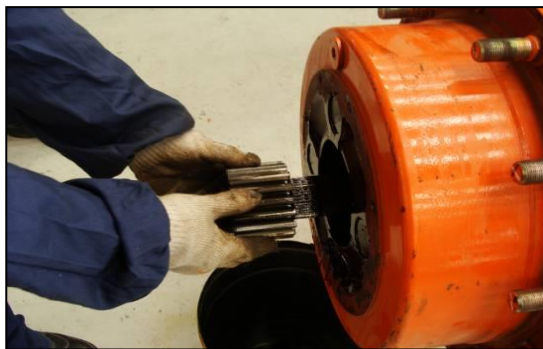

Figure 14

10. Dismantle locating block

Dismantle locating block from semi axle with hands.



Figure 15

11. Dismantle semiaxis

Take semiaxis from shell slightly.



Figure 16

12. Hub reducer

First loosen rim bolts with relative tools, then loosen rim from planet carrier with jackscrew and dismantle planet carrier assembly.

Note: *Please slowly loosen planet carrier to avoid safety hazard resulted from dropping of planet carrier assembly.*



Figure 17

13. O ring

Take out O ring from hub.

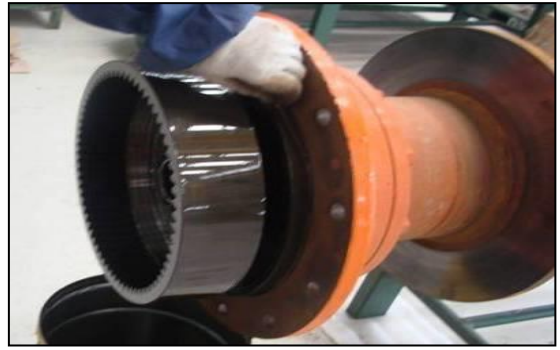

Figure 18

14. Dismantle round nuts

Pry up anti-loosing gasket of round nuts, then dismantle round nuts.



Figure 19

15. Dismantle internal gear

Take internal gear out by slightly rocking.



Figure 20

16. Dismantle rolling bearing

Take out rolling bearing with special dismantling tool.



Figure 21

17. Dismantle wheel hub assembly

Take wheel hub assembly from supporting axle.

Note: *During hanging and dismantling process, please keep axis of wheel hub assembly is in line with axis of hub reduction supporting axle to avoid scratching oil surface and internal spare parts during dismantling process.*



Figure 22

18. Dismantle spacer bush

Take out spacer bush.

Note: *Dismantle all parts at the other side with the same method.*



Figure 23

19. Dismantle of main drive assembly

Dismantle connection bolts between main drive and shell assembly, take out main drive with jackscrew, and suspend main drive assembly.

Note: *When suspending main drive assembly, guarantee suspending and dismantling tools are at the above of main drive assembly to avoid spare parts inside are knocked again during suspending and dismantling process.*



Figure 24

Assembly dismantling

Dismantle planet carrier assembly

1. Put planet carrier on working platform horizontally.



Figure 25

2. Take out planet axle with tools.



Figure 26

3. Take out steel balls.



Figure 27

4. Take out planet wheel.



Figure 28

5. Take out baffle ring and quill roller from inside of planet wheel.



Figure 29

Dismantle hub assembly

1. Put hub assembly on working platform.



Figure 30

2. Loosen connection bolts between brake disc and hub.



Figure 31

3. Take out brake disc.



Figure 32

4. Take out oil seal.



Figure 33

5. Take out baffle ring.

Note: *It must be clamped firmly when using baffle ring pincer to avoid safety hazard when it is popping out during assembling process.*



Figure 34

6. Take out bearing.



Figure 35

Dismantle main drive assembly

1. Put main drive assembly (input flange upward) horizontally and fixed on supporting.



Figure 36

2. Dismantle thrust bolts.



Figure 37

3. Dismantle locknut gasket, O ring and baffle ring.



Figure 38

4. Take out input flange.



Figure 39

5. Dismantle connection bolts between sealing cover and bearing sleeve, take out sealing cover.



Figure 40

6. Turn main drive for 180°, dismantle bolts fastening locking plate, take out locking plate.

Note: *Some of the machine structure may be different from this figure, please adjust working content according to actual structure.*



Figure 41

7. Dismantle bolts of fastening lock plate, take out lock plate.



Figure 42

8. Mark with signs so that they can be back to original position during assembling.



Figure 43

9. Dismantle connection bolts of bearing seat and take out bearing seat.



Figure 44

10. Dismantle adjusting nuts.



Figure 45

11. Dismantle bearing outer ring.



Figure 46

12. Hang out differential mechanism assembly.

Note: *Keep balance when hanging out to avoid safety hazard.*



Figure 47

13. Separate active spiral bevel gear assembly and bracket with jackscrew.



Figure 48

Dismantle differential assembly

1. Put differential assembly vertically on working platform, and guarantee it is stable.



Figure 49

2. Dismantle bearing on left and right shell of differential mechanism.



Figure 50

3. Loosen connection nuts between driven spiral bevel gear and right shell of differential mechanism, dismantle driven spiral bevel gear.

Note: Before taking out driven spiral bevel gear, please check or mark assembling sign first so that it can be placed back to the original position.



Figure 51

4. Loosen connection nuts of left and right shell, separate left and right shell of differential mechanism.

Note: Before separating left and right shell of differential mechanism, please check or mark assembling sign first so that it can be placed back to the original position.



Figure 52

5. Take out semiaxis gear gasket and semiaxis gear.



Figure 53

6. Take out joint cross and differential gear together, take out differential gear gasket and gear from joint cross.



Figure 54

7. Take out semiaxis gear gasket and gear.



Figure 55

Dismantle active spiral bevel gear assembly

1. Put active spiral bevel gear assembly on working platform, support flange of bearing sleeve, clamp down on thread end of active spiral bevel gear assembly with down device.

Note: Do not clamp too much to avoid damaging flange, pull out bearing sleeve from active spiral bevel gear assembly.



Figure 56

2. Reverse bevel gear assembly and take out bearing.



Figure 57

3. Take out bearing sleeve.



Figure 58

4. Take out adjusting gasket.



Figure 59

5. Take out spacer bush.



Figure 60

AXLE REASSEMBLY

Axle assembly

1. Shell

Clean shell and suspend with special supporting.
Fasten gummed plug screw at oil inlet and oil filler.

Note: Plug screw fastening torque: 175 ~ 235 Nm

Note: Loctite 262 taper thread sealant.



Figure 61

2. Spacer bush

Overturn shell and install bearing spacer bush.



Figure 62

3. Wheel hub assembly

Coat lubrication grease on hub supporting axle of shell assembly, assembly wheel hub assembly on both sides of supporting axle of shell assembly.

Note: Grapple the $\Phi 22.5$ hole on wheel hub with push and pull ergometer, pull ergometer along with tangential direction, indication on ergometer is $160 \pm 10N$, if the indication is not within the range of $160 \pm 10N$, adjust tightness degree of round bolts according to the indication until it is within the range of $160 \pm 10N$. In the end, coat Loctite 262 thread fastening sealant for 5~6 from the second thread hole of internal gear (form a liquid level at 1/3 circle of thread), then fasten bolts, and fix round nuts.



Figure 63

Note: Before dynamometry, rotate hub wheel for more than 5 times.

Loctite 262 thread fastening sealant



Figure 64

4. Bearing

Heat the inner ring of rolling bearing to 50°C~80°C and install on inner gear.



Figure 65

5. Internal gear

Assemble internal gear of drive axle at multiple spline at the end of supporting bearing.



Figure 66

6. Round nuts

Assemble round nuts and fasten. Knock internal gear slightly with copper stick to make internal gear in place.



Figure 67

7. Assemble O sealing ring

Assemble O sealing ring on hub assemble.

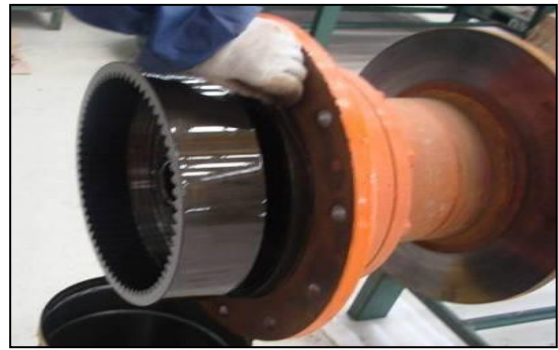

Figure 68

8. Install planet carrier assembly

Assemble planet carrier assembly and O sealing ring on wheel hub with rim bolts, gaskets and nuts.

Note: *fastening torque: 500±10Nm*



Figure 69

9. Assemble semiaxis

Install semiaxis assembly with sun gear on hub (pay attention to semiaxis multiple spline and gear assembly).



Figure 70

10. Assemble sun gear

Assemble sun gear at one side of semiaxis with baffle ring groove



Figure 71

11. Assemble baffle ring

Assemble baffle ring with baffle ring used for axle.

Note: *It must be clamped firmly when using baffle ring pincer to avoid safety hazard when it is popping out during assembling process.*



Figure 72

12. Assemble locating block

Stake steel ball on locating block, it can rotate flexibly after staking steel ball.



Figure 73

13. Assemble end cap

Coat Loctite 262 thread fastening sealant on screws, location of sealant is 15mm on top of thread end. Fasten cap with bolts and gaskets.

Note: *Fasten all screws according to symmetrical and crossing principle. Fastening torque : 110 ~ 130Nm
Loctite 262 thread fastening sealant*



Figure 74

14. Assemble brake caliper assembly

Assemble disc brake on brake caliper supporting, fix with bolts and gaskets.

Note: *Fastening torque: 550±40Nm
Coat Loctite 262 thread fastening sealant at 20mm length at thread end during assembling.*



Figure 75

15. Assemble main drive assembly

Coat Loctite 598 silicon rubber surface sealant at the joint surface between shell and bracket, coat $\phi 3 \sim \phi 6$ glue solution ring with sealing surrounding inside of thread hole at the large end of shell. The coated sealant cannot be in the air for more than ten minutes.

Note: *Loctite 598 silicon rubber surface sealant*



Figure 76

16. Assemble main drive

Hand up main drive assembly with overhead crane, put main drive at main drive shell of the axle, assemble locating pin.



Figure 77

17. Assemble bolts

Coat proper Loctite 262 thread fastening sealant on bolts, the coating position is 15mm length at thread end. Fasten main drive assembly and shell assembly with bolts and gaskets.

Note: *Fastening torque: 180 ~ 210Nm.*

Loctite 262 thread fastening sealant.

Fasten all screws according to symmetrical and crossing principle.



Figure 78

18. Add oil

Add 10L 85W/90 GL-5 gear oil (GB13895-1992) in axle bag of shell and fasten plug screws.

Note: *85W/90 GL-5 gear oil.*

Anaerobic type pipe thread sealant.

Fastening torque: 175 ~ 235 Nm.



Figure 79

Inject 4.5L (subject to overflowing from planet carrier) 85W/90 GL-5 gear oil (GB13895-1992) into two hub reducers and fasten plug screws.

Note: 85W/90 GL-5 gear oil

Anaerobic type pipe thread sealant

Fastening torque: 175 ~ 235 Nm



Figure 80

Assembly parts assembling

Install hub assembly

1. Keep the large end of hub upward, assemble bearing outer ring and turn over to keep the small end of hub upward and assemble bearing inner ring.



Figure 81

2. Install baffle ring



Figure 82

3. Coat lubrication oil at oil seal end, check completeness of oil seal, coat lubrication oil in groove of oil seal evenly, and assemble oil seal in side of oil seal end.



Figure 83

4. Assemble brake disc on hub and fasten with bolts and gaskets.

Note: *Fastening torque: $360\pm 20\text{Nm}$*

Fasten all screws according to symmetrical and crossing principle.



Figure 84

Install planet carrier assembly

1. Stick lubrication grease quill roller (27 units each) on walls of inner holes of planet gears, assemble baffle ring in the middle of quill roller, assemble gaskets at both sides of planet gear, then assemble to the seat hole of planet carrier.



Figure 85

2. Assemble steel balls in holes of planet gear shaft, steel ball shall aim at semi circle of planet carrier, go through the inner hole of planet gear and gasket and assemble on planet carrier. After assembly, planet gear shall rotate flexibly there is no blocking.



Figure 86

Assemble of main drive assembly

1. Assemble rolling bearing on bear neck of the terminal with pressure machine, rotate to the left on active spiral bevel gear front axle, and rotate to the right side.



Figure 87

2. Press inner ring into rolling bearing with pressure machine at the other side.



Figure 88

3. Turn over gear and assemble outer ring of gear.



Figure 89

4. Install spacer bush.



Figure 90

5. Assemble gasket.



Figure 91

6. Assemble bearing sleeve.



Figure 92

7. Press inner ring of antifriction bearing in the end.

Note: when assembling main reducer, taper rolling bearing shall have certain tightness, which is on the basis of eliminating bearing clearance, and give certain preload. The purpose is to reduce axial force caused during transmission process which will result in axial displacement, improve supporting rigidity, and guarantee normal mesh of bevel gear pair. But if it is too tight, it will accelerate abrasion of taper rolling bearing. Press with $P= 5420$ kg pressure at the top side of inner ring of rolling bearing, grapple $\Phi 14.5$ hole with pull and push ergometer, pull ergometer along with tangential direction, indication of ergometer when pushing shall be 17.34-30.06N, if the indication is not within the range of 17.34-30.06N, increase or reduce thickness of spacer shim, repeat the above process until the indication is within 17.34-30.06N.



Figure 93



Figure 94

Assemble of differential assembly

1. Assemble rolling

Bearing at the bearing position of right shell terminal of differential mechanism.



Figure 95

2. Assemble rolling bearing at the bearing position of left shell terminal of differential mechanism.



Figure 96

3. Assemble semiaxis gear
Assemble semiaxis gear gasket in left shell of differential mechanism.

Note: *the side of gasket with groove shall toward to the direction of joint cross*



Figure 97

4. Assemble semiaxis gear



Figure 98

5. Assemble joint cross assembly
Assemble bevel gear (internal of small terminal) and bevel gear gasket on four axles of joint cross.

Note: *lubricate with grease when assembling bevel gear and bevel gear gasket*



Figure 99

6. Differential mechanism shell

Assemble joint cross in right shell of differential mechanism to make bevel gear and semiaxis gear mesh, turn over left shell assembly of differential mechanism to assemble right shell assembly of differential mechanism, join right shell and left shells of differential mechanism with bolts and fasten with gaskets and nuts.

Note: *nuts tightening torque 180 ~ 210Nm*

Note: *Guarantee assembling mark of right shell and left shell of differential mechanism align.*

Note: *Coat proper Loctite 262 thread fastening sealant at the thread bottom within 12mm length.*

Note: *After assembling, semiaxis gear and taper gear can be rotated manually without blocking.*



Figure 100

7. Assemble driven spiral bevel gear

Aim at assembling mark, fasten driven spiral bevel gear (rotate to the left for rear axle, rotate to the right for front axle) with bolts, gaskets and nuts, and fasten screws.

Note: *Nuts fastening torque 280±25Nm.*

Note: *Coat proper Loctite 262 thread fastening sealant at the thread bottom within 12mm length.*

Note: *Judging method of left and right spiral: face to positive side of gear, right rotation refers to the spiral gear rotates to large terminal clockwise; on the contrary, left rotation refers to the spiral gear rotates to large terminal anticlockwise.*



Figure 101



Figure 102

Assemble main reducer

1. Install the assembled active spiral bevel gear assembly in bracket



Figure 103

2. Coat sealant line with diameter 2-4mm at the small end, refer to the picture for sealant line; sealant line and diameter of bearing sleeve (the other side of gasket) shall be done according to the above requirements.

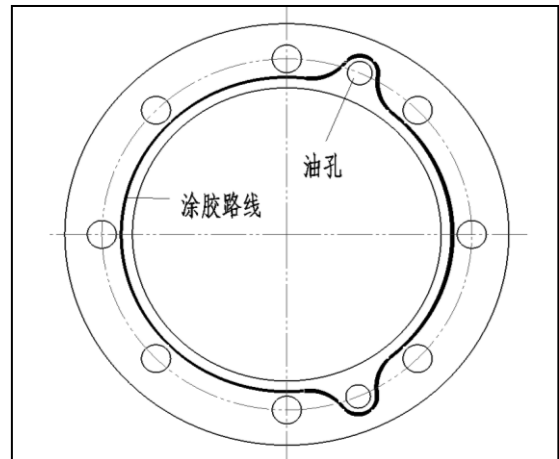

Figure 104

3. Assemble sealing cover

Press oil seal in sealing cover.

Note: Coat a layer of proper lubrication oil when assembling oil seal.



Figure 105

4. Install input flange

Put gasket on the end face of bracket, install sealing cover assembly (coat lubrication grease on oil seal according to common requirements of drive axle), and connect with bracket with bolts and gaskets.

Note: Screw fastening torque 180 ~ 210 Nm



Figure 106

5. Install input flange.



Figure 107

6. Install baffle ring, O ring, coat sealant on one end face of gasket, the surface with sealant is downward, install gasket.

Note: *Loctite 598 sealant*



Figure 108

7. Install gasket



Figure 109

8. Install round screws and fasten.

Note: *Screw fastening torque: 320 ~ 400 Nm*

Note: *Before installing flange, install flange on multiple spline on main spiral bevel gear, measure radial play eccentricity of flange, guarantee it cannot be more than 0.08, and mark matching and assembling signs. If it is out of tolerance, rotate flange to certain angle and measure until it complies with requirements, otherwise, replace flange.*

Note: *Gasket shall be close to $\phi 2 \sim \phi 3$ glue line.*



Figure 110

9. Install differential assembly

Turnover bracket, install differential assembly in bracket.



Figure 111

10. Install bearing seat with gaskets and bolts (bolts shall be a little bit tight). Install adjustable nuts.

Note: Two bearing seats cannot be exchanged.

Note: Coat proper thread sealant on the length of 15~25mm on thread end surface of bolts.



Figure 112

11. Adjust spiral bevel gear

Adjustment of spiral bevel gear mesh condition refers to adjustment of mesh zone and back lash, when adjusting back lash of spiral bevel gear pair, dial gauge can be used to touch the gear surface of large side edge of driven spiral bevel gear, then rotate driven spiral bevel gear to measure back lash directly, the clearance shall be 0.2~0.35mm. Adjusting method of back mesh is to twist adjusting nuts to change position of driven spiral bevel gear (when it is necessary, move active spiral bevel gear assembly to adjust). If the clearance is larger than the regulated value, approach active spiral bevel gear from driven spiral bevel gear; otherwise be away from it. In order to keep the adjusted preload of taper rolling bearing of differential mechanism, twisting numbers of adjusting nuts at one side shall be equal to twisting numbers of adjusting nuts at the other side.



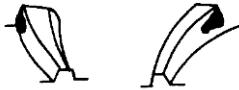
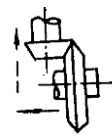
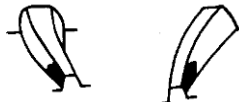

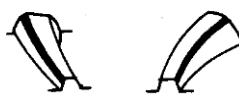
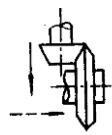
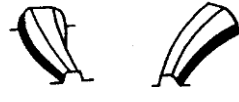

Figure 113



Figure 114

When adjusting contact zone of spiral bevel gear pair, coat red color (red lead powder) on driven spiral bevel gear teeth (coat three teeth usually), rotate driven spiral bevel gear with hands repeatedly, check contacting moulage. Adjust the correct position of spiral bevel gear mesh moulage: it shall not be less than 50% along with teeth height direction and teeth length direction, mesh moulage of driven bevel gear shall be close to the center, and in the middle of teeth height, smaller than the small end on teeth length direction. Increasing preload of differential bearing: after adjusting back lash of spiral bevel gear well, it shall guarantee the clearance between taper rolling bearing at both sides of differential mechanism is 0. Following is the adjusting methods.

Adjustment of contact zone and back lash when installing spiral bevel gear

Contact zone of driven spiral bevel gear	Adjusting method	Gear moving direction
	Move driven gear to the direction of active gear, if the clearance is too small, move active gear outside	
	Move driven gear away from active gear, if the clearance is too large, move active gear inside	
	Move active gear to the direction of driven gear, if the clearance is too small, move driven gear inside and outside	
	Move active gear away from driven gear, if clearance is too large, move driven gear inside	

Method of adjusting mesh zone is usually increasing and decreasing adjusting gaskets and rotating adjusting nuts. Adjusting of contact zone will affect performance and service life greatly, it shall be carried out carefully.

Note: After adjusting, clean off red lead powder.

12. Install locking plate

Fasten the fixed bolts on bearing seat, fastening torque is 410 ~ 510Nm. Put locking plate at the right position, fix it on bearing seat with bolts and gaskets, and fasten fixing bolts of locking plate.

Note: *fastening torque 40 ~ 50Nm*

Note: *Coat proper Loctite 262 thread fastening sealant on 5-10mm length at the end surface of fixing bolt.*

Note: *Coat Loctite 262 thread fastening sealant*



Figure 115

13. Install thrust bolts

Overturn carrier, press copper cover into the side with thrust bolts, twist into the center of carrier, make copper contact with the back of driven spiral bevel gear of differential assembly, reverse for 1/6-1/4 circles, fasten with nuts and lock plate.

Note: *Loctite 598 sealant*



Figure 116

14. Bend one of the teeth of lock pate to avoid loosening of nuts.



Figure 117

AIR CONDITIONER

CAUTION!

Follow all safety recommendations and safe shop practices outlined in the front of this manual or those contained within this section.

Always use tools and equipment that is in good working order.

Use lifting and hoisting equipment capable of safely handling load.

Remember, that ultimately safety is your own personal responsibility.

TABLE OF CONTENTS

General Description.....	3
Circulation of Refrigeration Agent.....	4
Control Panel.....	6
AC System Circuit Diagram	7
Maintenance.....	8
Trouble Shooting.....	10

GENERAL DESCRIPTION

Heater and AC evaporator share one air blower, and it is located at the front side of driving cab. When it is necessary, the driver can install it in control panel room at the right of control platform to control indoor temperature.

AC of the machine has three functions of refrigeration, heating and natural wind.

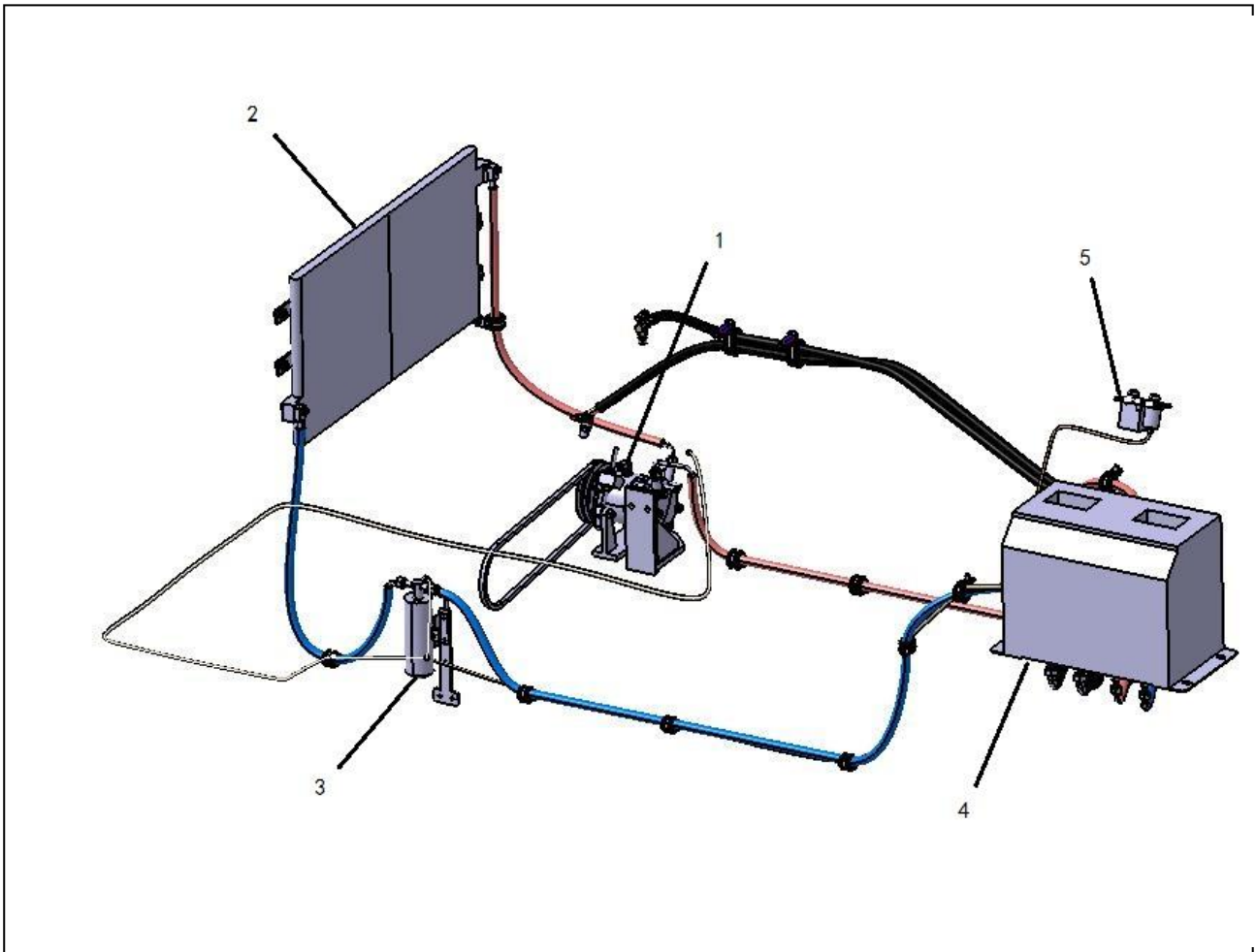

Figure 1 AC system schematic diagram

Reference Number	Description	Reference Number	Description
1	Compressor	4	Evaporator
2	Condenser	5	Control Panel
3	Receiver/Drier		

Circulation of refrigeration agent

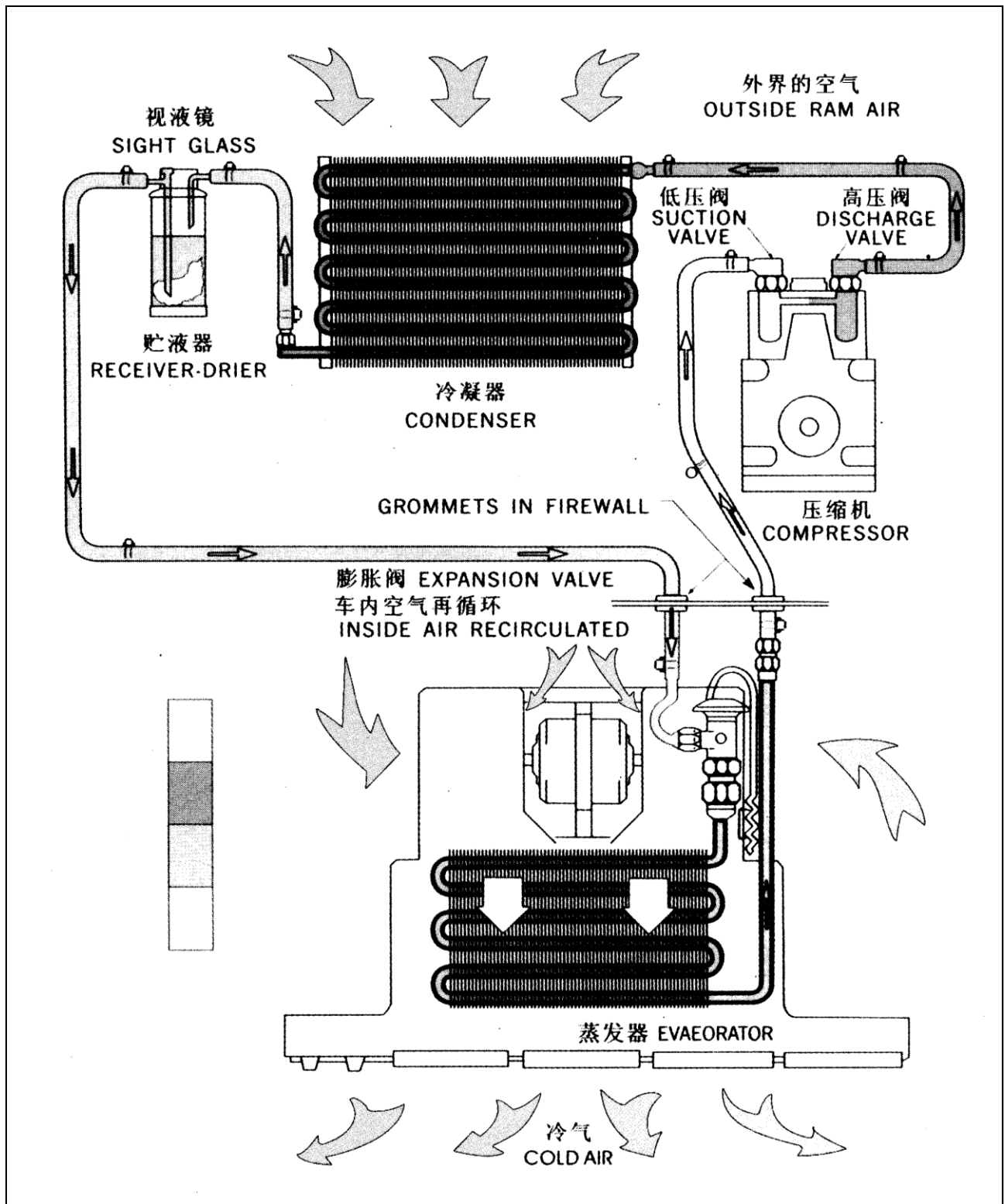

Figure 2 Refrigeration agent circulation schematic diagram

- Refrigeration agent (R134a) is compressed to 15kg/cm² (213psi) within sight view.
- Compressed refrigeration agent flows into condenser under high temperature (about 80°C (176°F)).
- Refrigeration agent of condenser is cooled down by condensation fan to about 60°C. At the same time, refrigeration agent is changed from gas state to liquid state, even if the temperature is reduced from 80°C (176°F) to 60°C (140°F) .
- Refrigeration agent is sprayed to evaporator in gas state through expansion valve. And pressure is reduced for 2 kg/cm² (28psi) , and temperature is reduced, too. The result is refrigeration agent absorbs heat from surrounding air to create refrigeration effect, refrigeration agent is changed from gas state to liquid state.
- Refrigeration agent flows into compressor in gas state again and repeat the above process.

CAUTION!

Refrigeration agent is compressed and sealed in AC system. Special protective measures are needed when injecting or releasing refrigeration agent correctly. It is strictly controlled by laws to release refrigeration agent into air. Before maintaining or repair AC, please obey the orders of all federation, states and districts, refrigeration agent used in the system must reach or exceed R134a specifications or environmental standards issued later.

Control panel

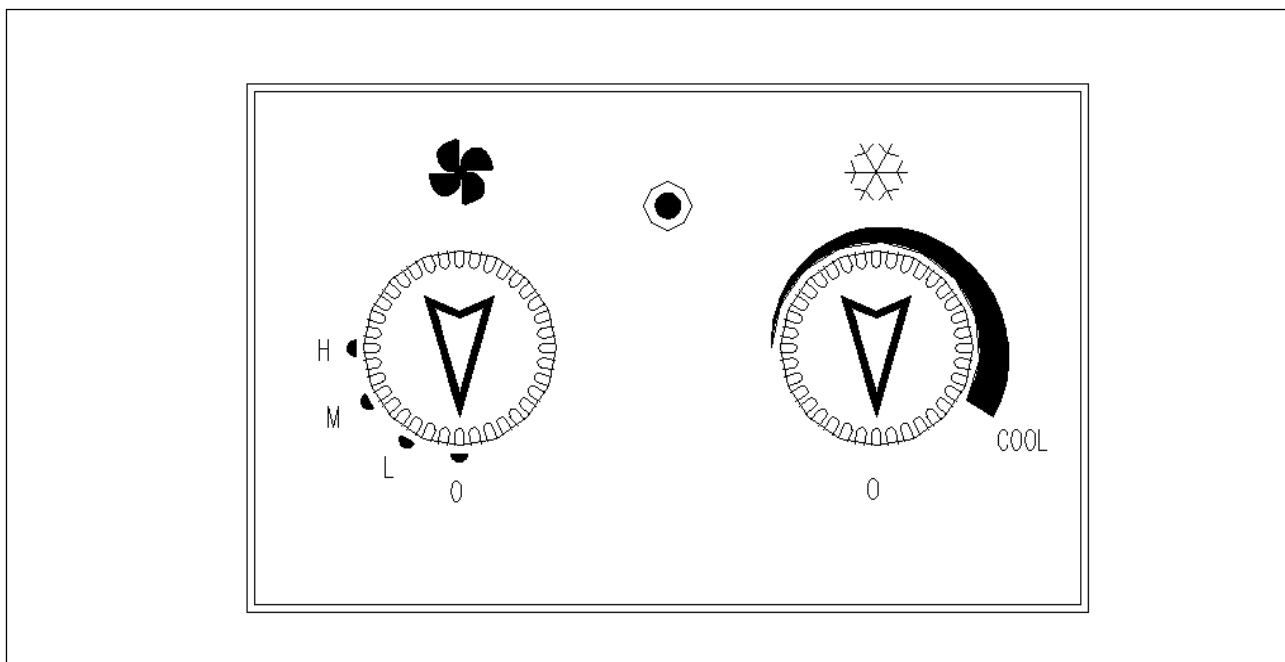

Figure 3 AC control panel diagram

Control specifications

Control item	Control switch	Control specifications
Rotation speed control of air blower	"CLOSE" switch "LOW SPEED" switch "INTERMEDIATE SPEED" switch "HIGH SPEED" switch	<p>HI RELAY</p> <p>MID RELAY</p> <p>LOW RELAY</p> <p>OFF LOW MID HI</p>
Compressor control	Temperature sensor	<p>COMP ON</p> <p>COMP OFF</p> <p>1.5 °C 4.0 °C</p>

AC system circuit diagram

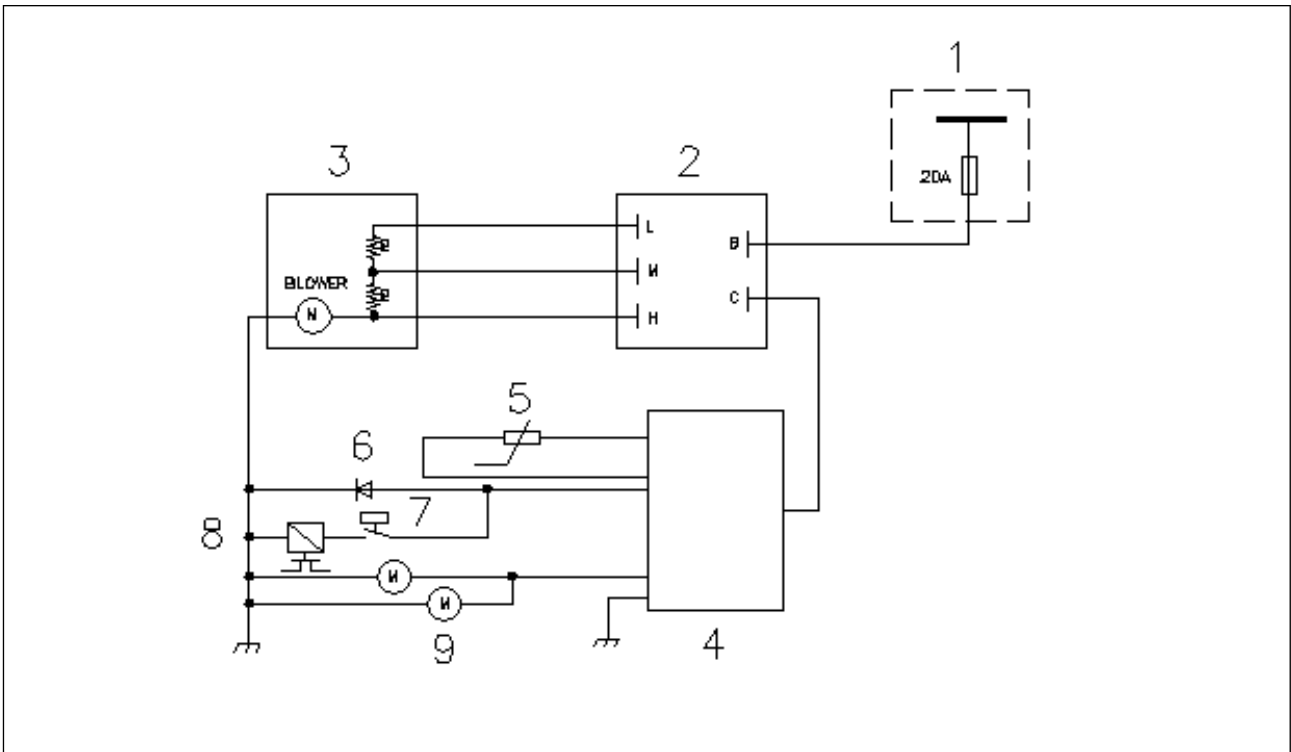

Figure 4 AC system circuit diagram

Reference Number	Description	Reference Number	Description
1	Fuse Box	6	LED
2	Blower Switch	7	Press. Cut Off Switch
3	Blower	8	Compressor
4	Thermistor	9	Condenser
5	Temperature Sensor		

Maintenance

1. AC outdoors radiator-“condenser” must be cleaned regularly; refer to figure 5.

Treatment method: dismantle condensing fan, condenser is completely exposes, wash with water, but do not use high water pressure to avoid lodging of condenser fan and affect radiation effect.

Maintenance standard: wash once a month in summer, if working environment is too bad, increase washing times properly.

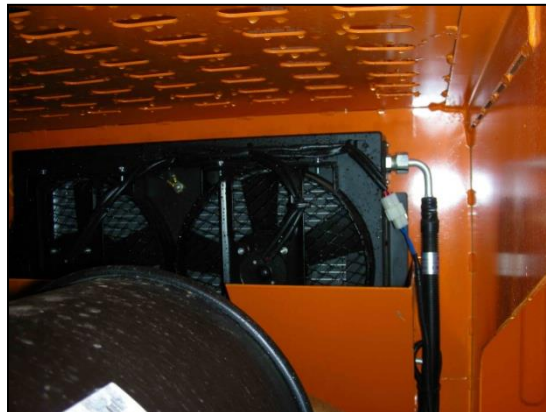

Figure 5

2. Check if fixed bolts of compressor are loosed regularly, if belt of compressor is loosed; refer to figure 6.

Checking method: visually check if AC bolts are loosed, checking method of belt tightness degree: put about 10kg force on middle of belt, force is downward, descending amplitude of belt is about 10-15mm, it cannot be too high or too low; maintenance standard: check once a week in summer.



Figure 6

3. Check if there is refrigeration agent in the system

Checking method: check Freon injection mouth of compressor head (refer to the picture), screw off plastic plug, poke with keys or other sharp things (its structure is like the air tap of tyre), check if there is large amount of air jets out, if there is no air or air current is very small, it proves that Freon is leaked (wear gloves and protect eyes during operation, do not burn skin and eyes with refrigeration agent).



Figure 7

4. Power on checking of the entire machine. Open AC control panel, turn III gear switch to H gear and check if there is wind coming from evaporator and if wind is big enough. Turn on temperature control switch on AC control panel and turns to the maximum position, check if indication light is on, at the same time, listen if AC compressor is absorbing (turn on and turn off temperature control switch repeatedly, there should be clear and melodious absorbing “Pitter-patter” at compressor).

5. Confirmation of charging amount of refrigeration. Agent charging amount of refrigeration agent R134a of the AC system is $1000\pm 50g$, the process is vacuumizing, charging and retrieving.



Figure 8

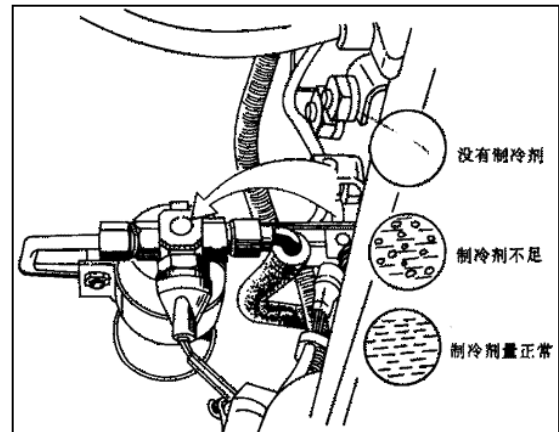

Figure 9

Comparison table between liquid sight glass state of reservoir and trouble analysis

Liquid sight glass state	Trouble analysis
Liquid sight glass is locate, bubbles can be seen at the moment of turning on and turning off AC, and bubbles become transparent suddenly.	Freon charging quantity is proper
Few bubbles flowing, compressor head is hot, refrigeration output is not enough, high and low pressure of the system are both very low.	Freon charging quantity is not enough or the system is leaking
Turn on and turn off AC, it is hard to see bubbles flowing, compressor head is cold, high and low pressure of the system are both high.	Freon is over charged
Freon charging is proper, AC does not refrigerate, it is hard to see bubbles flowing in reservoir, low pressure is negative.	Expansion valve is dirty and blocked or frozen and blocked, it shall be solved by professional personnel

Trouble shooting

Following is the common troubles and reasons

1. The entire AC system is power off
 - Reason analysis
 - Fuse of AC is burnout.
 - Wiring harness of AC power is not connected.
2. Evaporation fan is running, after turning on temperature control switch, indication light is not on, condensation fan and compressor do not work.
 - Reason analysis
 - Indoor temperature of driving cab is lower than 4°
 - Temperature sensing detector is open circuit or not connected.
 - AC temperature control switch relay is broken.
3. Evaporation fan rotates, condensation fan rotates, compressor does not absorb
 - Coil of compressor clutch is broken
 - High/low pressure switch is broken.
 - Freon is leaked
 - Circuit from high/low pressure switch to compressor is open.
4. Evaporation fan does not run, condensation fan runs, compressor absorbs
 - Earth wire of evaporation fan drops, or earth wire contact is not good.
 - Ill gear switch is broken
 - Evaporation fan is broken

Transmission and Torque Converter

CAUTION!

Follow all safety recommendations and safe shop practices outlined in the front of this manual or those contained within this section.

Always use tools and equipment that is in good working order.

Use lifting and hoisting equipment capable of safely handling load.

Remember, that ultimately safety is your own personal responsibility.

TABLE OF CONTENTS

Brief Introduction.....	3
Basic Parameters of Transmission.....	3
External Structure of Transmission	4
Front View.....	5
Left View	6
Back View	7
Internal Structure of Transmission	8
Oil Supply System of Transmission	10
Disassembly of Transmission	12
Disassembly of Transmission Assembly	12
Assembly Parts Dismantling.....	20
Assembling of Transmission	33
Assembly of the Transmission	33
Assembly Parts Assembling.....	39

Brief introduction

Basic parameters of transmission

T/M and T/C Ass'y Model	ZL50B
Product Model	SD300N Wheel Loader
Torque Converter	Single-stage, Two-phase, Four-element (Dual-turbine)
Rated Input Speed	2000 R/Min
Rated Input Power	154 KW
Cooling Method	Circulated Water Cooling
Torque Ratio	4.14
Inlet Oil pressure of T/C	0.30~0.45 MPa
Outlet Oil pressure of T/C	0.20~0.30 MPa
Max. permissible Temp. at outlet of T/C	120 °C
Hydraulic Oil Pressure	1.10~1.40 MPa
T/M Type	Power Shift, Planetary Structure
Shift	Two Forward and One Reverse Gears
Gear Ratio of F1	2.547
Gear Ratio of F2	0.683
Gear Ratio of R1	1.864

External structure of transmission

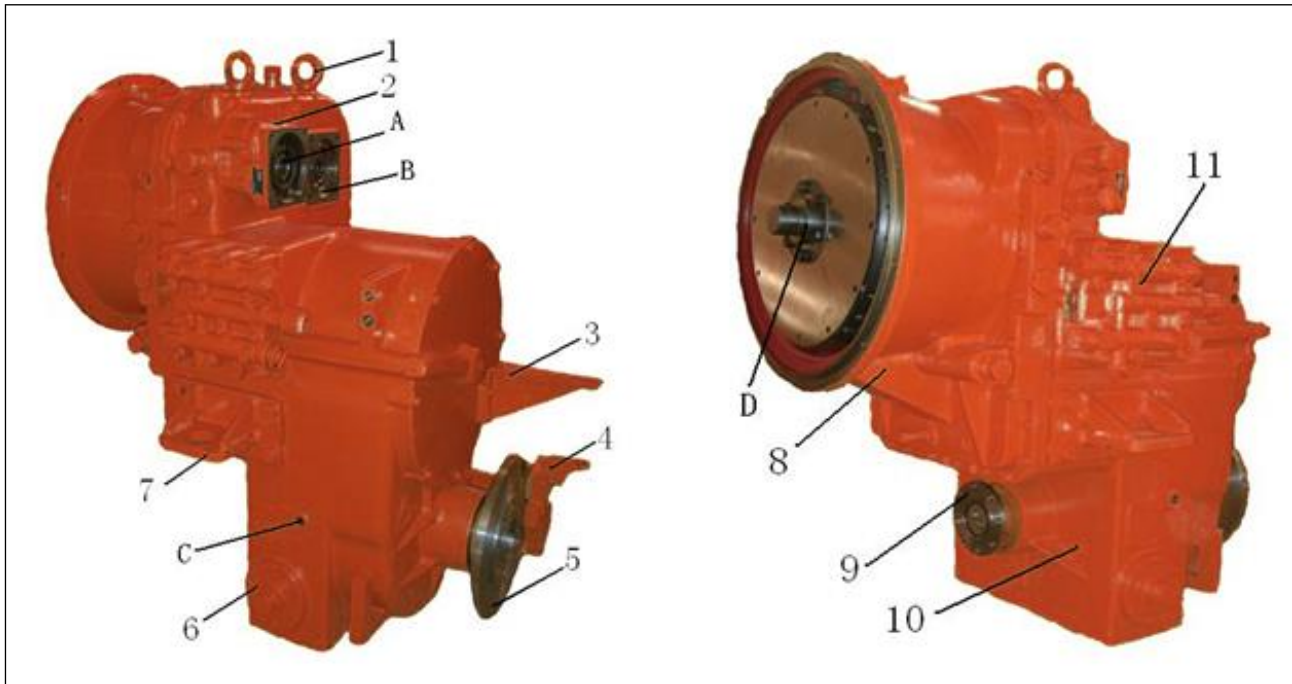

Figure 1

Reference Number	Description	Reference Number	Description
1	Ring	9	Rear Flange
2	Oil Pump	10	T/M Housing
3	Bracket	11	Shift Valve
4	Parking Brake	A	Port of Working Pump
5	Front Flange	B	Port of Steering Pump
6	Flange of Oil Suction System	C	Oil Level Port
7	Assembly Bracket	D	Power Input Port
8	Torque Converter Ass'y		

Front view

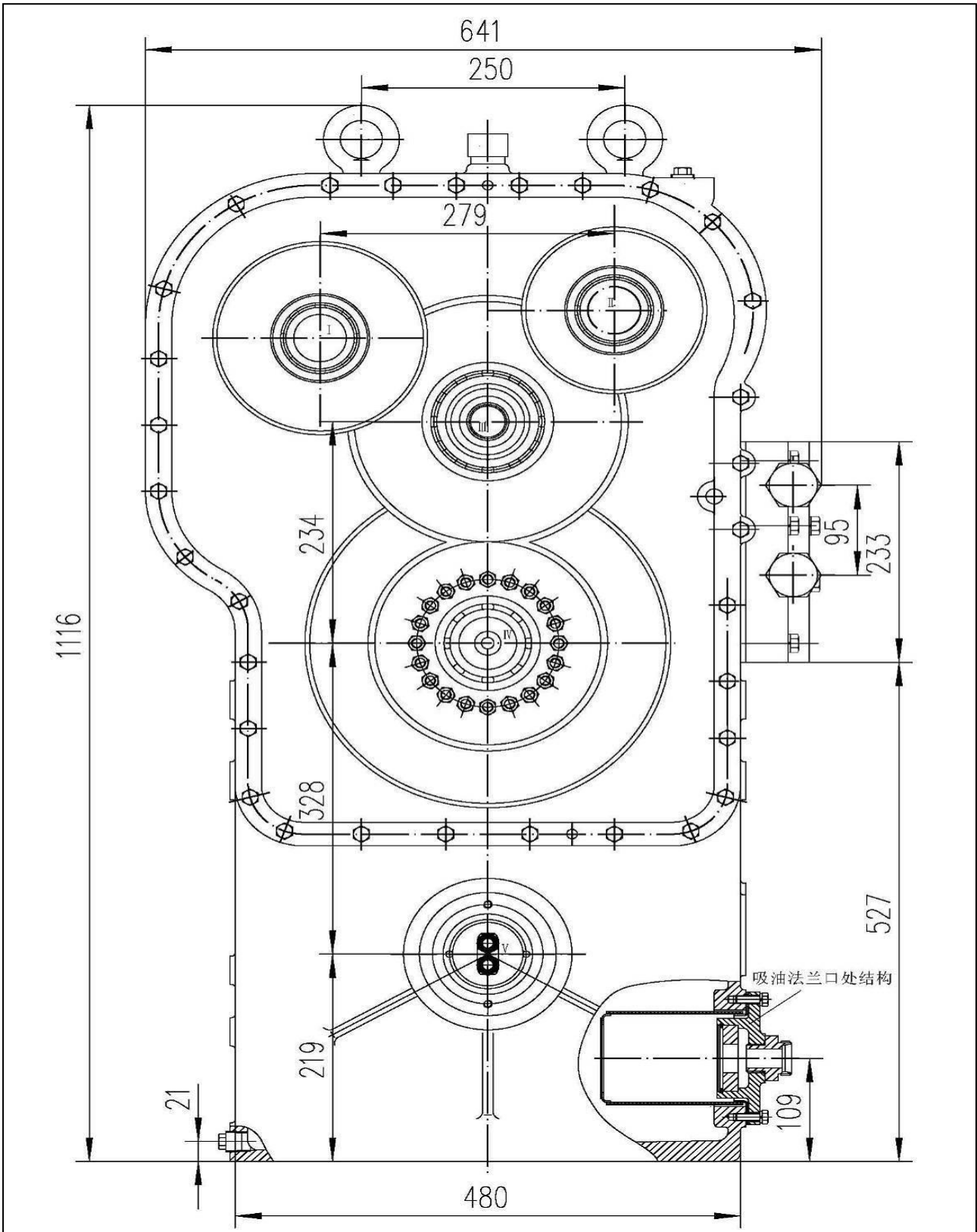

Figure 2

Left view

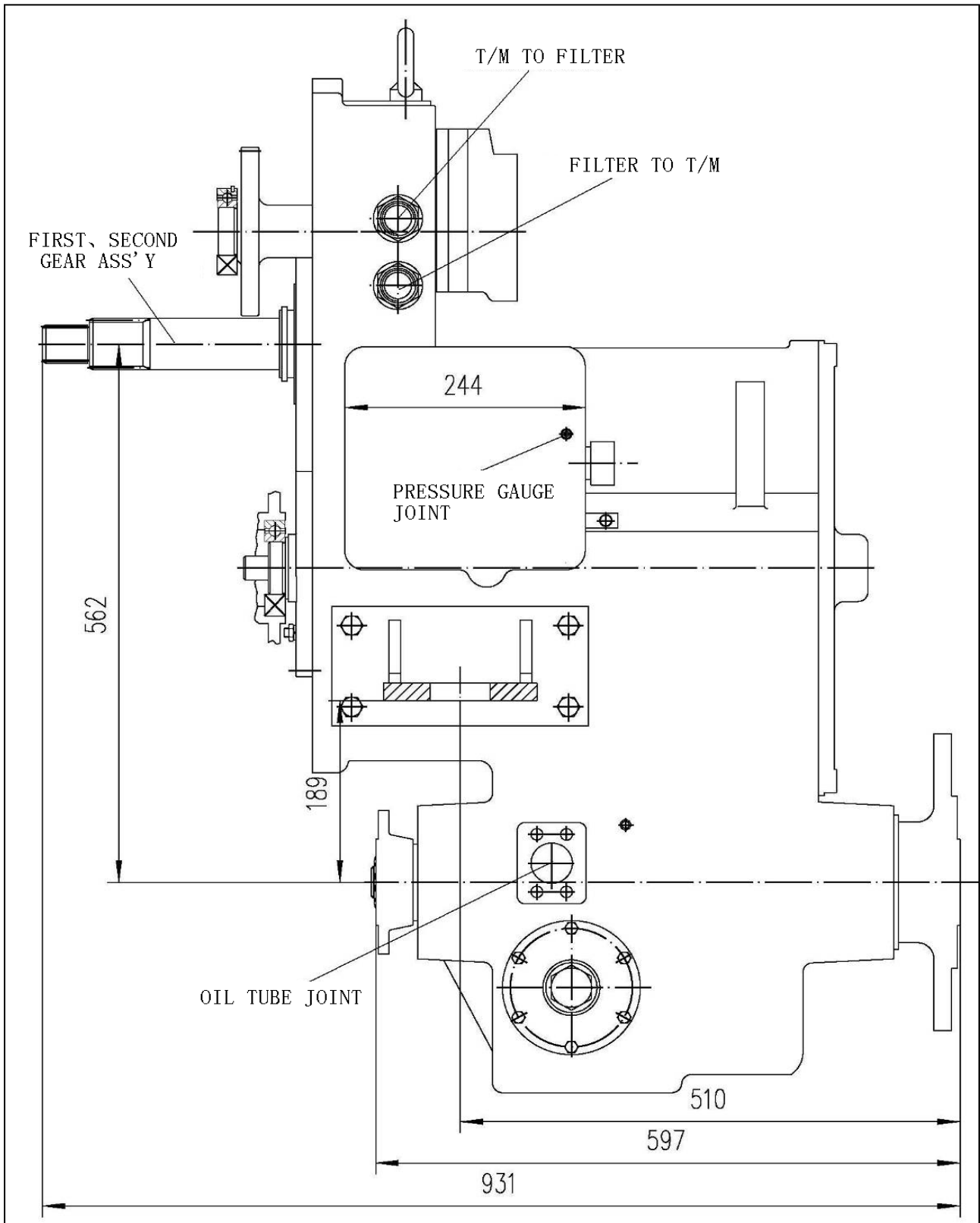
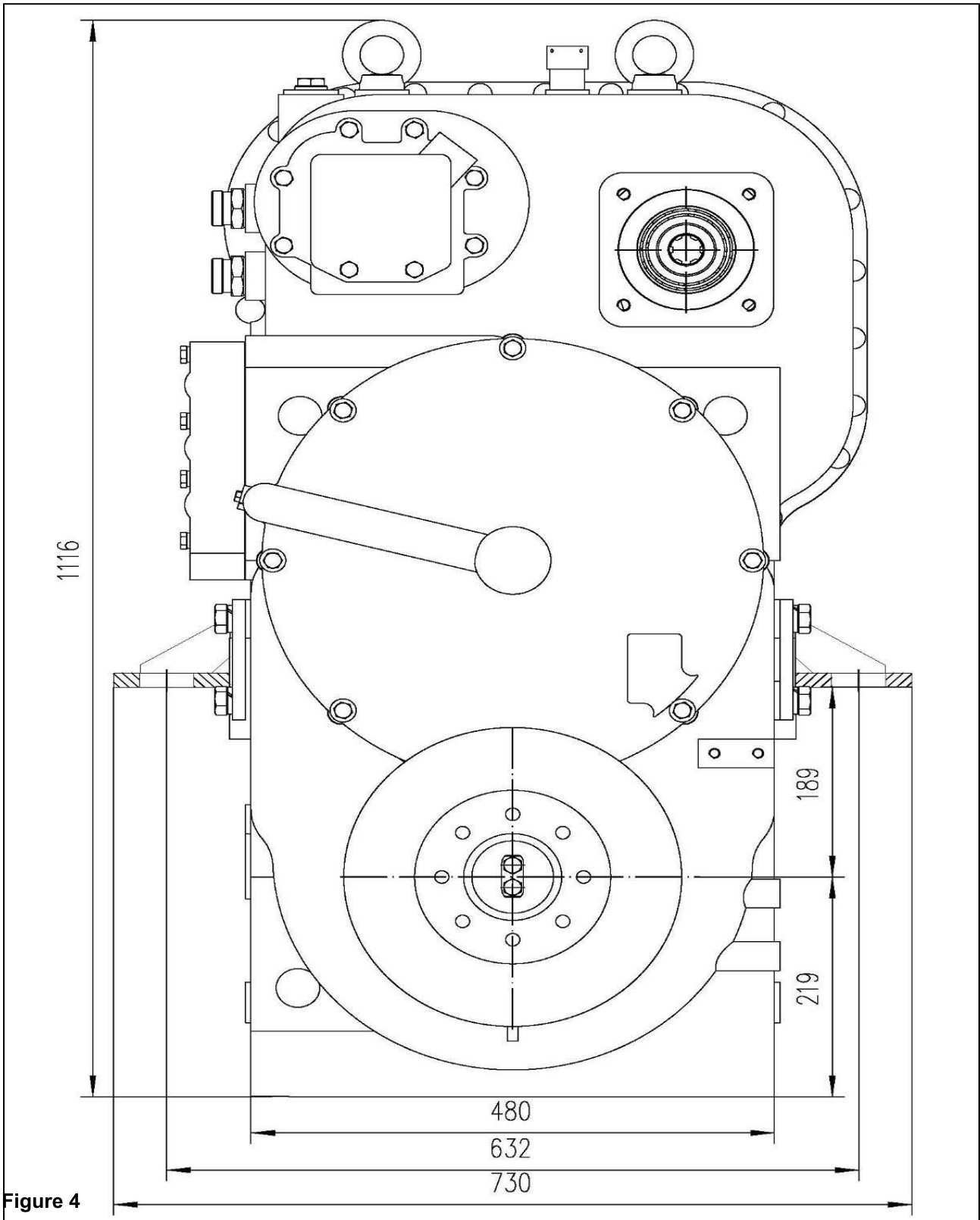

Figure 3

Back view



Internal structure of transmission

Power generated by engine is transferred to gear shifting gearbox through hydraulic torque converter, the gearbox is composed of planet variable speed part and driven gear, its internal structure is shown in figure 5. Planet variable speed part has two planet rows: reverse gear planet row (herein after referred to as reverse gear assembly) which is composed of planet wheel, reverse gear planet structure, reverse gear planet axle, baffle ring, gasket, bolts, quill roller, stop washer and bearing; first gear planet row (herein after referred to as first gear assembly) is composed of gear terminal pad, planet wheel, first gear planet structure, first gear planet axle, annular gear of reverse gear, arresting disc, baffle ring, quill roller, bearing, gasket and bolts, teeth of sun gear, planet gear and gear ring of these two planet rows are the same. Direct gear assembly (that is the second gear, same as following) is composed of direct gear pressure disc, direct gear piston, direct gear cylinder, intermediate output gear, butterfly spring, active and driven rotor plate of direct gear, direct gear axle, bearing, baffle ring, sealing ring, pin, rotation oil seal, gasket, nuts and mild steel wire.

Two planet rows use the same sun gear to transfer power, sun gear is connected with intermediate input axle and direct gear input axle through multiple spline, it is part of power output.

Reverse gear internal gear ring, I gear planet row structure and direct gear pressure disc (direct gear pressure disc and intermediate output gear are fixed together) are connected together through multiple spline, it is power output device of planet variable speed part.

Active and driven friction plate of reverse gear and I gear are installed in reverse gear planet structure and internal gear ring. They are connected with active friction plate through teeth. Driven friction plate is guided by isolated column pin fixed on shell and transfers power to shell. Compaction of active and driven friction plate depends on effect of oil cylinder piston; when active and driven friction plates are separated, piston resets along with the resetting spring.

Direct gear has two active friction plates and one driven friction plate, they are connected by bolts and direct gear input axle. Direct gear has only one driven rotor plate, it is guided by isolated column pin on direct gear pressure disc and transfers power to direct gear pressure disc. Compaction of clutch depends on oil pressure pushing piston; piston returns according to butterfly spring when during separation.

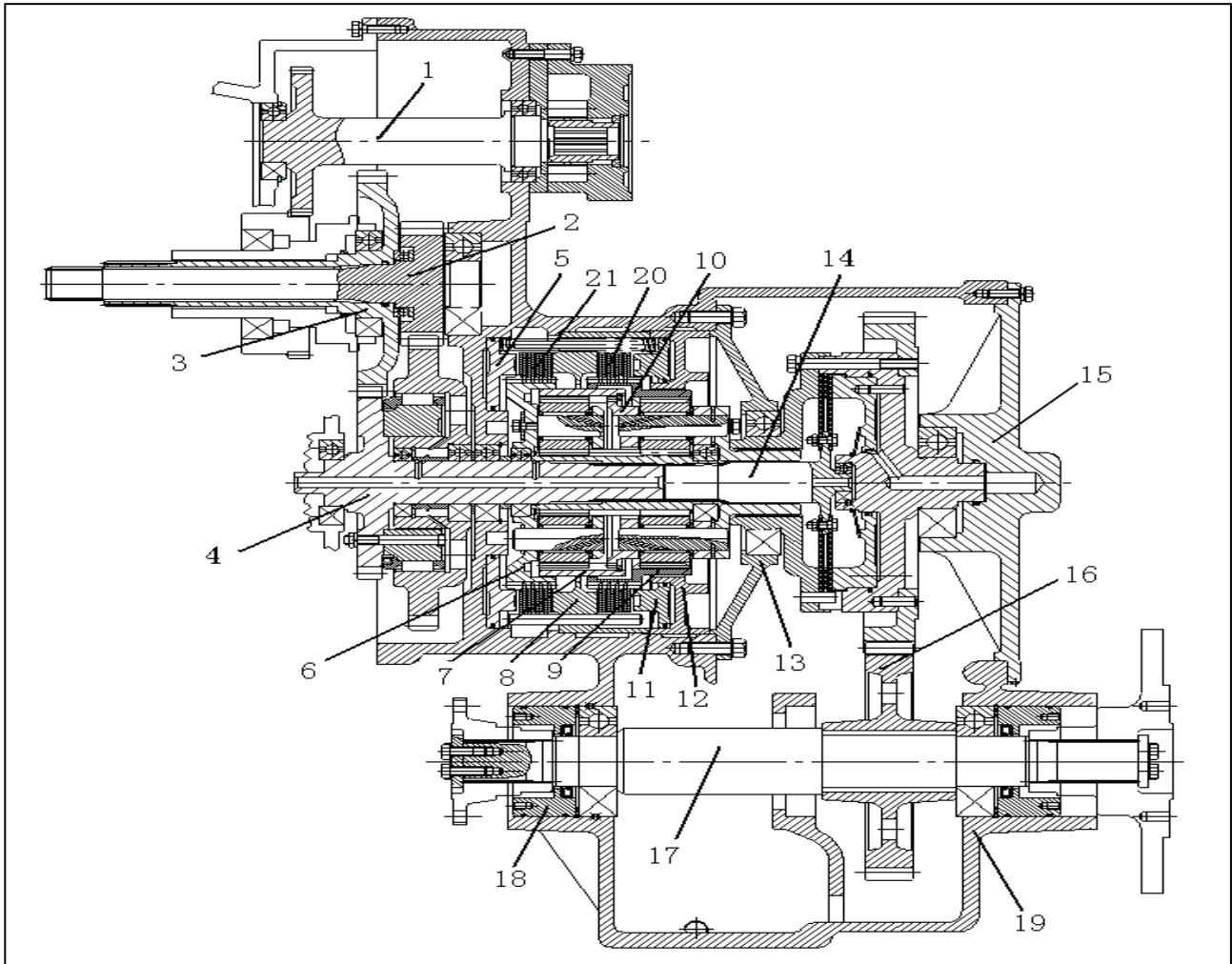

Figure 5

Reference Number	Description	Reference Number	Description
1	Gear-shaft Ass'y	12	Cylinder of F1
2	F1 Input Gear Ass'y	13	Mid-Cover
3	F2 Input Gear Ass'y	14	F2 Ass'y
4	Over Clutching Ass'y	15	End-Cover
5	Piston of R1	16	Output Gear
6	R1 Ass'y	17	Output Shaft
7	Gear Ring of R1	18	Oil seal seat assembly
8	Segregate Frame	19	Housing
9	Gear Ring of F1	20	Friction Plates of F1
10	F1 Ass'y	21	Friction Plates of F1
11	Piston of F1		

Oil supply system of transmission

Please refer to figure 6 for work principle of oil supply system of gearbox.

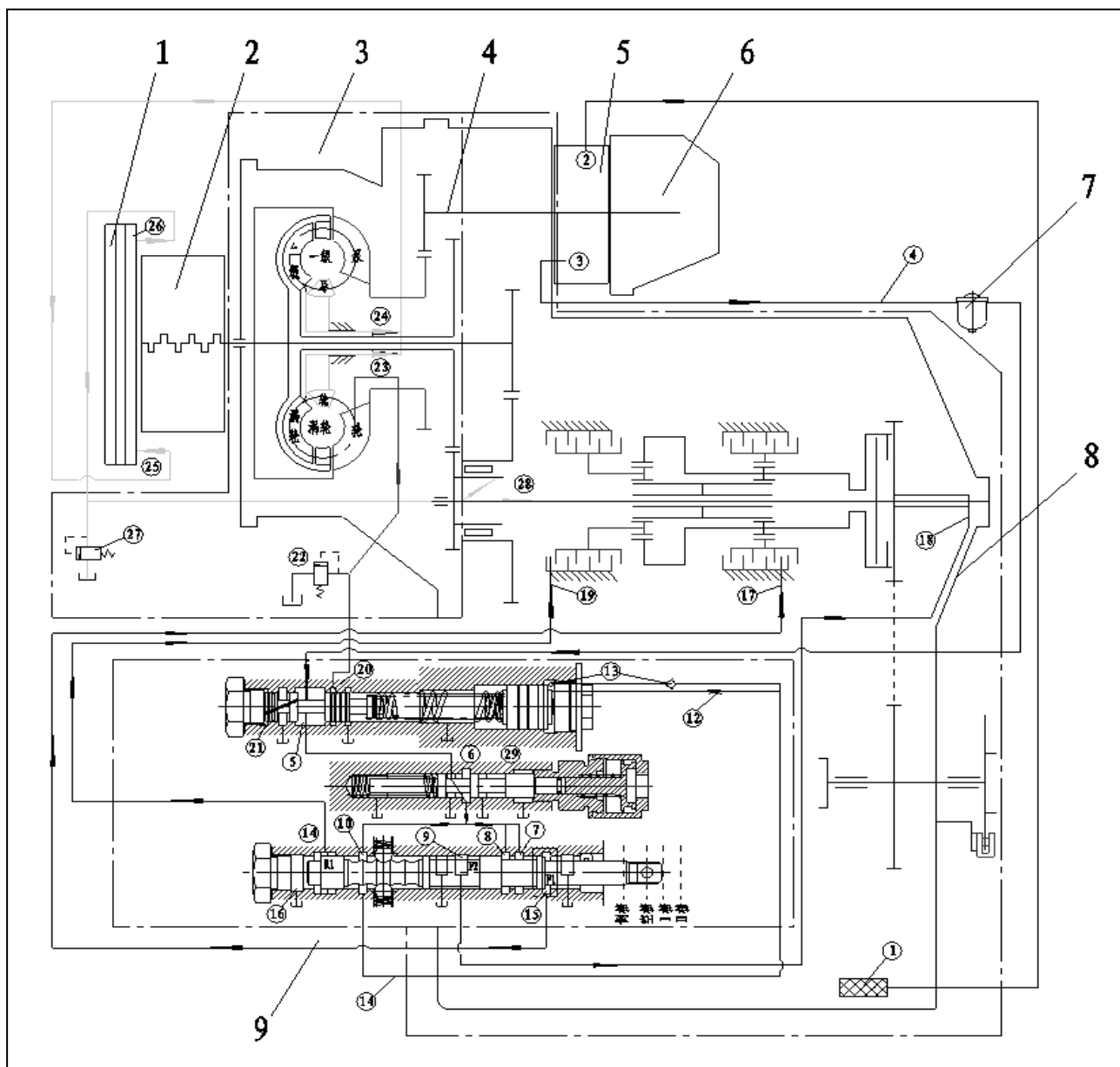

Figure 6

Reference Number	Description	Reference Number	Description
1	Radiator	6	Working Pump
2	Diesel Engine	7	Oil Filter
3	Torque Converter	8	Transmission
4	Gear Shaft	9	Shift Valve
5	Oil Pump		

Transmission oil supply system is composed of variable pump 5, variable operating valve 9, oil filter 7, radiator (cooler 1), oil tank (composed of oil pan and tank) and oil cylinder (clutch).

When diesel engine drives torque converter rotating, transfer gear and variable pump gear 4 drive variable pump to suck oil from oil pan. Pressure oil from variable pump enters variable operating valve through oil filter (when oil filter element is blocked, bypass valve is turned on). Since then, pressure oil is divided into two ways: one way enters variable operating oilway through relief valve ($P=1.08\sim 1.47\text{MPa}$), and enters cylinder of different gears from different position of variable valve rod to finish different gears. In variable oilway, stop valve can stop oilway going to variable valve rod according to requirements; the other road will go into work chamber of torque converter.

When oil is fill in variable tank, work oil will enter the left side (21) of valve rod through slant hole on relief valve rod to push valve rod move to the right, the orifices (5) is connected with (10), and begins to supply oil to torque converter, and keep certain pressure in torque converter chamber. Part of the constant oil going into torque converter will circulate in pump pulley, I and II grade turbines and guide wheel; the other part will enter oil groove of guide wheel seat through clearance of working wheels, go into radiator (cooler) through orifices (24), (25), (26) and (27) and lubrication oilway to lubricate bearings and overrunning clutch. Oil from torque converter goes into radiation device through hose for radiation to keep normal working temperature of oil supply system. It is better to keep oil temperature between $80^{\circ}\text{C}\sim 90^{\circ}\text{C}$, it can reach 120°C in short time, too high oil temperature will make dynamic property of loaders decrease obviously. Loaders shall be stopped immediately to cool down. After radiation, low pressure oil will go back to torque converter, and lubricate overrunning clutch and planet rows through holes on shell.

When gearbox shifting gears, I gear, II gear and reverse gear can be realized according to the gear shifting position shown in the figure. Oil supplying way of forward I gear is pressure regulating valve→ stop valve→ orifices(7)→ orifices(15) →I gear clutch orifices. Oil supplying way of forward II gear is pressure regulating valve→ stop valve→ orifices(8)→ orifices(9)→direct gear clutch orifices. Oil supplying way of reverse gear is pressure regulating valve→ stop valve→ orifices(10)→ orifices(14)→reverse gear clutch orifices.

Disassembly of transmission

Disassembly of transmission assembly

1. Disassemble torque converter assembly.

Keep torque converter upward, put transmission assembly on supporting and fix, loosen and dismantle bolts between torque converter and transmission.

Torque converter: about 150Kg

Separate torque converter and transmission with jackscrew, hang transmission away from torque converter assembly, put torque converter assembly on work platform vertically. Jackscrew: M10

Note: *Hanging tools must be guaranteed above the torque converter, do not grab combination surface of transmission with hands to avoid hurt hands.*



Figure 7

2. Dismantle the third shaft assembly from tank body.



Figure 8

3. Screw in the relative thread holes of overrun clutch with two jackscrews, separate tank body and suspend it away.

Jackscrew: M14



Figure 9

4. Suspend overrunning clutch.



Figure 10

5. Dismantle space ring.



Figure 11

6. Loosen bolts of variable speed valve with relative tools, dismantle variable speed valve and take out sealing gaskets.

Note: Put variable speed valve at clean place, cover oil way surface to avoid dust and sundries entering into valve.



Figure 12

7. Dismantle oil pan.



Figure 13

8. Loosen bolts with relative tools and take out fixed plate.



Figure 14

9. Take out flange.



Figure 15

10. Dismantle oil seal seat assembly with special tools.

Note: *If there is corrosion at the combination surface of tank body and oil seal seat, get rid of corrosion to avoid damage tank and oil seal seat surface. When special tool is not adopted, get out the oil seal seat horizontally with even force.*



Figure 16

11. Take out baffle ring with baffle ring pincer.

Note: *It must be clamped firmly when using baffle ring pincer to avoid safe hazard when it pops out from tank body.*



Figure 17

12. Overturn gearbox, dismantle hand brake assembly.



Figure 18

13. Take out baffle ring with baffle ring pincer.

Note: *It must be clamped firmly when using baffle ring pincer to avoid safe hazard when it pops out from tank body.*



Figure 19

14. Loosen bolts of variable pump, dismantle variable pump and take out sealing gaskets.

Note: *Put variable pump at clean place, cover oil way surface to avoid dust and sundries entering into valve.*



Figure 20

15. Loosen bolts with relative tools and separate end cap from tank body with two jackscrews. Jackscrew: M10



Figure 21

16. Suspend direct gear assembly.



Figure 22

17. Separate and take out intermediate cover with jackscrew. Jackscrew: M10

Note: *Since there are 15 resetting springs are located at the surrounding are of intermediate cover, in order to avoid intermediate cover is popped out and hurt people because of over force when dismantling intermediate cover, fix two screw holes of intermediate cover with two M14×50 bolts, when loosening connecting bolts, stop when loosen 15mm of two bolts of opposite angle, dismantle the rest 6 bolts, and loosen the remaining 2 bolts slowly, then take out intermediate cover with two M14×50 bolts.*



Figure 23

18. Dismantle I gear cylinder with hands, take out piston, and internal and external sealing rings.



Figure 24

19. Take out resetting spring and spring guide pin with hands.



Figure 25

20. Take out friction plates.

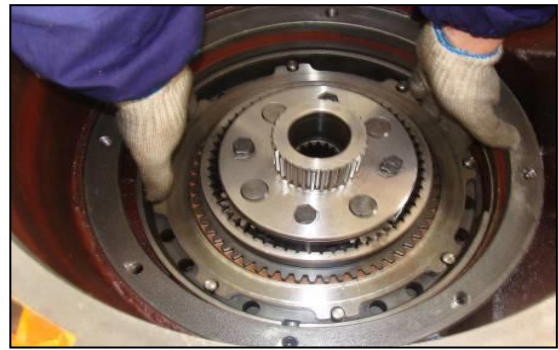

Figure 26

21. Take out I gear ring, separate from friction plates.



Figure 27

22. Take out I gear planet structure assembly.



Figure 28

23. Pry out isolated stop pin with screw driver.

Note: *Do not touch.*

The surface of tank body when prying out stop pin.



Figure 29

24. Take out isolated structure assembly.



Figure 30

25. Take out friction plates.



Figure 31

26. Take out reverse gear planet wheel structure assembly with hands.



Figure 32

27. Take out reverse gear piston, internal and external sealing elements.



Figure 33

28. Take out spring baffle ring of four axle hole of tank body with baffle ring pincer.

Note: *It must be clamped firmly when using baffle ring pincer to avoid safe hazard when it pops out from tank body.*



Figure 34

29. Dismantle output axle.

Note: *Use balance strength to avoid output axle hurts surface.*

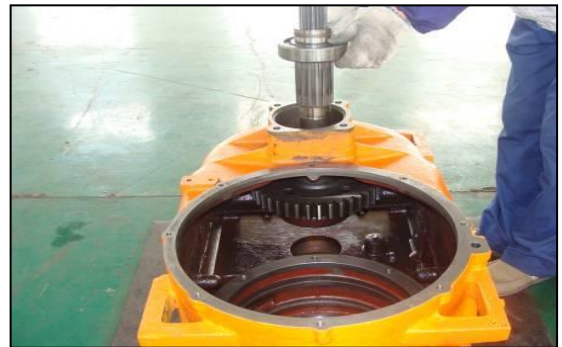

Figure 35

30. Take out output axle gear.



Figure 36

31. Take out bearing.



Figure 37

Transmission assembly parts disassembling

Disassembly of direct gear assembly

1. Put direct gear on work platform horizontally, dismantle connecting bolts.



Figure 38

2. Take out intermediate output gear.



Figure 39

3. Overturn and take out direct gear pressure disc with hands.



Figure 40

4. Take out three friction plates.



Figure 41

5. Take out direct gear axle.



Figure 42

6. Take out baffle ring with baffle ring pincer.

Note: *It must be clamped firmly when using baffle ring pincer to avoid safe hazard when it pops out from tank body.*



Figure 43

7. Take out butterfly spring with hands.



Figure 44

8. Take out direct gear piston with hands.



Figure 45

9. Take out sealing ring and rotation oil seal of direct gear piston with hands.

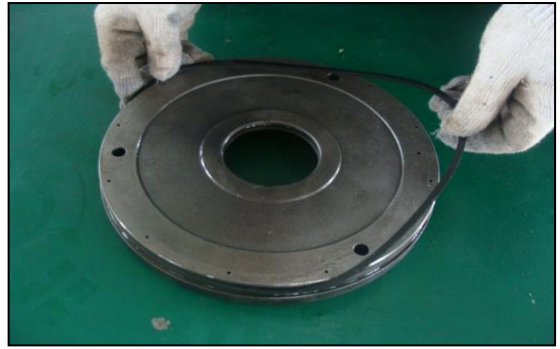

Figure 46

10. Take out bearing of pressure disc.



Figure 47

11. Take out bearing of direct bearing axle.



Figure 48

Disassembly of I gear assembly

8. Put I gear assembly on platform, dismantle connecting bolts of direct gear terminal pad.



Figure 49

9. Take out terminal pad of direct gear.



Figure 50

10. Take out arresting disc with hands.



Figure 51

11. Pry out baffle ring of reverse gear inner gear ring with screwdriver.

Note: Do not use too much strength to avoid accidents caused by popping out of baffle ring.



Figure 52

12. Separate inner gear ring from planet wheel structure, take out inner gear ring.



Figure 53

13. Take out I gear planet axle.



Figure 54

14. Take out planet wheel and gasket with hands.



Figure 55

15. Take out baffle ring and quill roller of planet wheel with hands.



Figure 56

16. Take out bearing of active gear.



Figure 57

Disassembly of reverse gear assembly

1. Put reverse gears on platform horizontally, dismantle bearing.



Figure 58

2. Dismantle bolts and arresting gasket of reverse gear planet axle.



Figure 59

3. Take out reverse gear planet axle.



Figure 60

4. Take out planet wheel and gasket with hands.



Figure 61

5. Take out baffle and quill roller of planet wheel.



Figure 62

Disassembly of overrunning clutch assembly

1. Put overrunning clutch on platform, press big gear wheel with pressure machine and take out bearing.



Figure 63

2. Take out gear.



Figure 64

3. Take out spacer bush.



Figure 65

4. Overturn and dismantle connecting nuts between intermediate input axle and inner ring cam.



Figure 66

5. Bind bolts with rubber band, take out isolation ring, inner ring cam, 24 rolling balls and bolts together.

Note: *Structure of some machine models are different from this picture, please adjust work content according to actual structure.*



Figure 67

6. Take out gasket.



Figure 68

7. Take out bearing of intermediate input axle.



Figure 69

8. Take out bearing of the other side.



Figure 70

9. Take out bearing of general output gear.



Figure 71

Disassembly of input I grade gear assembly

1. Dismantle bearing.



Figure 72

Disassembly of input II grade gear assembly

1. Dismantle baffle ring of axle.



Figure 73

2. Dismantle bearing



Figure 74

3. Dismantle gear.



Figure 75

4. Dismantle location block.



Figure 76

5. Dismantle bearing of the other side.



Figure 77

Disassembling of hydraulic torque converter assembly

1 . Put torque converter on work platform horizontally, dismantle connecting bolts.



Figure 78

2. Take out gasket.

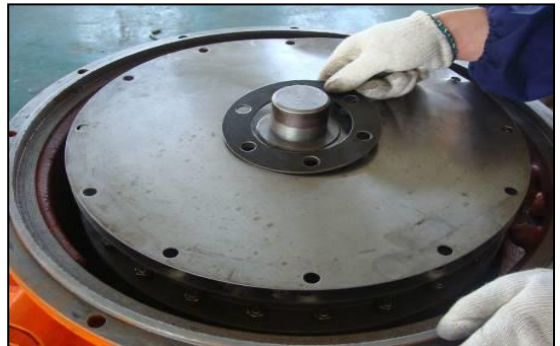

Figure 79

3. Dismantle elastic plate.



Figure 80

4. Take out gasket.



Figure 81

5. Dismantle fixed bolts and take out cover wheel.



Figure 82

6. Dismantle fixed bolts of guide wheel.



Figure 83

7. Take out guide wheel.



Figure 84

8. Dismantle fixed bolts.



Figure 85

9. Take out gasket.

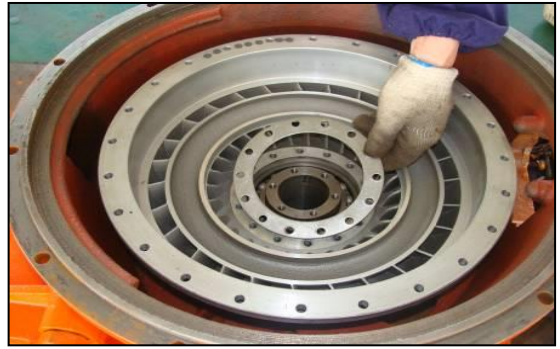

Figure 86

10. Take out pump pulley.

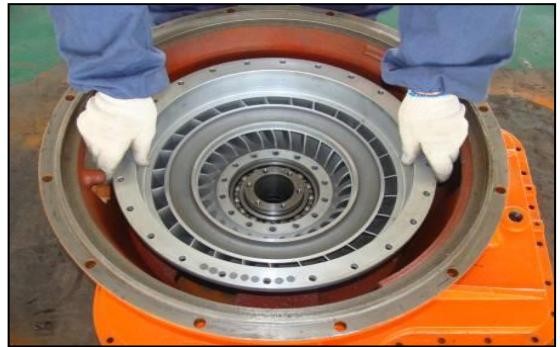

Figure 87

11. Take out bearing.



Figure 88

12. Take out output gear.



Figure 89

Assembly of transmission

1. Put clean tank body on work platform, do not let it swing, install bearing.

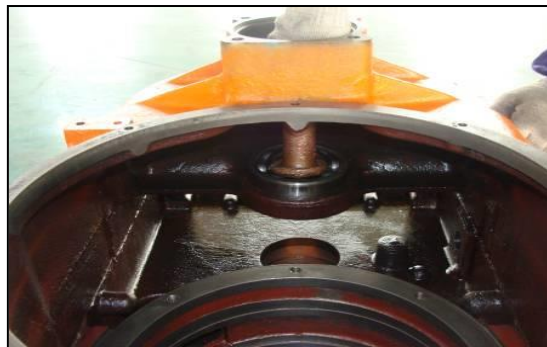

Figure 90

2. Install output axle gear.



Figure 91

3. Install output axle.



Figure 92

4. Install reverse gear piston, internal and external sealing.



Figure 93

5. Install spring baffle ring of four axle holes with baffle ring pincer.



Figure 94

6. Install reverse gear planet wheel structure assembly.



Figure 95

7. Install friction plate.



Figure 96

8. Install isolated structure assembly.



Figure 97

9. Install I gear planet wheel structure assembly.



Figure 98

10. Install I gear ring and friction plate.



Figure 99

11. Install resetting spring and spring guide pin.



Figure 100

12. Install isolated structure arresting pin.

Note: Coat with proper grease.



Figure 101

13. Install I gear piston, internal and external sealing.



Figure 102

14. Install intermediate cover, and twist bolts.

Note: *Fastening torque: 124~165Nm*



Figure 103

15. Install direct gear assembly.



Figure 104

16. Install end cap sealing gaskets.



Figure 105

17. Install end cap and twist bolts.

Note: *Fastening torque: 45~59Nm*



Figure 106

18. Install bearing



Figure 107

19. Install variable pump and twist bolts.

Note: *Fastening torque: 45~59Nm*



Figure 108

20. Install spacer bush.



Figure 109

21. Install hand brake assembly.

Note: *Fastening torque: 78~104Nm*



Figure 110

22. Overturn transmission, install space ring.



Figure 111

23. Install overrunning clutch.



Figure 112

24. Install torque converter assembly.

Note: *Fastening torque: 45~59Nm*



Figure 113

25. Install oil seal seat and flange.

Note: *Fastening torque: 22~30Nm*



Figure 114

26. Install oil pan.

Note: *Fastening torque: 45~59Nm*



Figure 115

27. Install variable speed valve and twist bolts.

Note: *Fastening torque: 45~59Nm*



Figure 116

Assembly parts assembling

1. Fix torque converter body, install output gear.



Figure 117

2. Heat inner hole of bearing to 50 ~ 80°C on heating machine and install.



Figure 118

3. Install pump pulley.

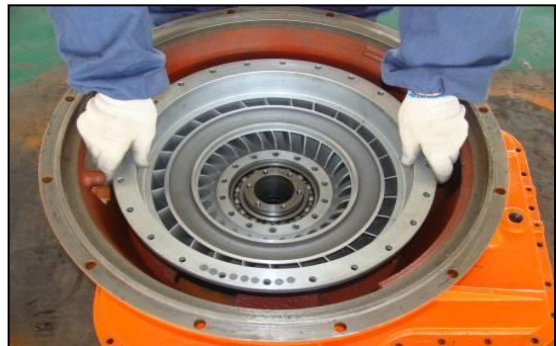

Figure 119

4. Install gasket.



Figure 120

5. Twist fixed bolts.

Note: *Fastening torque: 22 ~ 30Nm*

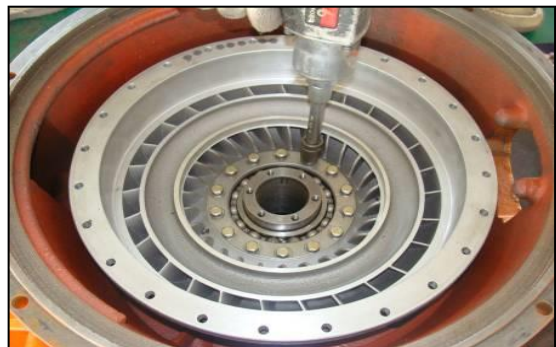

Figure 121

6. Install guide wheel and twist fixed bolts.

Note: *Fastening torque: 22~30Nm*



Figure 122

7. Install cover wheel and twist fixed bolts.

Note: *Fastening torque: 22~30Nm*



Figure 123

8. Install elastic plate.



Figure 124

9. Install gasket and twist fixed bolts.

Note: *Fastening torque: 78~104 Nm*



Figure 125

10. Overturn tank body and fix, install spacer bush.



Figure 126

11. Twist fixed bolts.

Note: *Fastening torque: 45~59Nm*

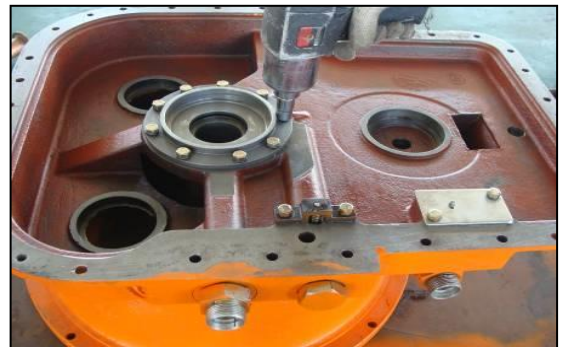

Figure 127

12. Install low speed gear.



Figure 128

13. Install high speed gear.



Figure 129

14. Install input II grade gear.



Figure 130

15. Install input I grade gear.



Figure 131

Assembling of input I grade gear

1. Heat inner hole of bearing to 50~80°C on heating machine and install it to shaft end of input I grade gear.



Figure 132

Assembling of input II grade gear

1. Heat inner hole of bearing to 50~80°C on heating machine and install it to shaft end of input II grade gear.



Figure 133

2. Install gear



Figure 134

3. Heat inner hole of bearing to 50~80°C on heating machine and install it to shaft neck of input II grade gear.



Figure 135

4. Install baffle ring.



Figure 136

Assembling of reverse gear assembly

1. Coat lubrication grease in four holes of planet wheels, stick quill roller on inner hole wall [22 for each] of planet wheel 1, quill rollers shall be tidy, and two sides of each hole is installed with one baffle ring.



Figure 137

2. Install four planet wheel assembly and gasket into seat hole of planet structure, install reverse gear planet axle [4 units].



Figure 138

3. Install bolts and gaskets and screw on.
Install bearing I n reverse gear planet structure.

Note: *Fastening torque: 22~30Nm*

Note: *After installation, planet wheel can rotate flexibly, there is no blockage, reverse gear planet axle should not have punching mark of hard things, choose relative quill roller during installation, the Max. And the Min. diameter of the same group quill roller shall be less than 0.005, roundness and column degree allowance shall be less than 0.003.*



Figure 139

Assembling of I gear assembly

1. Coat lubrication grease in four holes of planet wheels, stick quill roller on inner hole wall [22 for each] of planet wheel 1, quill rollers shall be tidy, and two sides of each hole is installed with one baffle ring.



Figure 140

2. Install four planet wheel assembly and gasket [8 units] into seat hole of planet structure, install reverse gear planet axle [4 units].



Figure 141

3. Install arresting disc, rotate arresting disc to make it blocked at the notch of I gear planet axle, install direct gear terminal pad.



Figure 142

4. Install baffle ring on bearing, and install them together on I gear planet structure.

Note: After installation, planet wheel can rotate flexibly, there is no blockage, reverse gear planet axle should not have punching mark of hard things, choose relative quill roller during installation, the Max. and the Min. diameter of the same group quill roller shall be less than 0.005, roundness and column degree allowance shall be less than 0.003.



Figure 143

5. Install parts which are finished in the above procedures on gear ring of reverse gear, and lock with baffle ring.



Figure 144

6. Screw on fixed bolts.

Note: Fastening torque: 22~30Nm



Figure 145

Assembling of direct gear assembly

1. Install bearing of direct gear.



Figure 146

2. Install direct gear ring.

Note: *Fastening torque: 22~30Nm*



Figure 147

3. Install sealing ring of cylinder.



Figure 148

4. Install bearing of cylinder.



Figure 149

5. Install direct gear piston on oil cylinder.



Figure 150

6. Install butterfly spring in direct gear cylinder.



Figure 151

7. Block butterfly spring with baffle ring.



Figure 152

8. Install direct gear axle on cylinder.



Figure 153

9. Install direct gear active rotor and driven rotor on direct gear axle.



Figure 154

10. Install pressure disc.



Figure 155

11. Install general output gear.



Figure 156

12. Screw on pressure disc and cylinder with bolts.

Note: After installation, pack oilway mouth with plastic cloth to avoid sundries.

Note: Screw on bolts according to symmetrical and crossing principle.

Note: Fastening torque: 78~104Nm



Figure 157

Assembling of overrunning clutch

1. Heat inner hole of bearing to 50 ~ 80°C on heating machine and install on intermediate input axle.

**Figure 158**

2. Heat inner hole of bearing to 50 ~ 80°C on heating machine and install to the other side.

**Figure 159**

3. Bind bolts with rubber band; install isolation ring, inner ring cam, 24 rolling balls and bolts together on intermediate input axle.

**Figure 160**

4. Screw on fixed bolts

Note: *Fastening torque: 45 ~ 59Nm*

**Figure 161**

5. Install spacer bush..



Figure 162

6. Install general output gear.



Figure 163

7. Heat inner hole of bearing to 50~80°C on heating machine and install.



Figure 164

HYDRAULICS

CYLINDERS

 CAUTION!

Follow all safety recommendations and safe shop practices outlined in the front of this manual or those contained within this section.

Always use tools and equipment that is in good working order.

Use lifting and hoisting equipment capable of safely handling load.

Remember, that ultimately safety is your own personal responsibility.

TABLE OF CONTENTS

General Description.....	3
Working principle.....	3
Detailed List of Spare Parts.....	4
Disassembling and Assembling Steps.....	5

General Description

Working principle

It is usually composed of cylinder body, piston rod and sealing parts, internal of cylinder body is divided into two parts and connect with a oil hold respectively. Since compression of liquid is very small, when oil coming into one oil hole, piston will be propelled to make oil going out from another oil hole, piston drives piston rod stretching (compressing), on the contrary as before.

Cylinder is the implementing part of the straight line movement of output force and piston effective area and the pressure difference at both sides. It is used to change hydraulic energy into mechanic energy. The input of cylinder is flow rate and pressure of fluid, the output is speed and force of straight line movement. Piston of cylinder can finish straight line alternating motion, the output straight line displacement is limited. Cylinder is the energy converting device from hydraulic energy to mechanic energy for alternating straight line movement. Cylinder is basically composed of cylinder barrel, cylinder cover, piston, piston rod, sealing device and cushioning device.

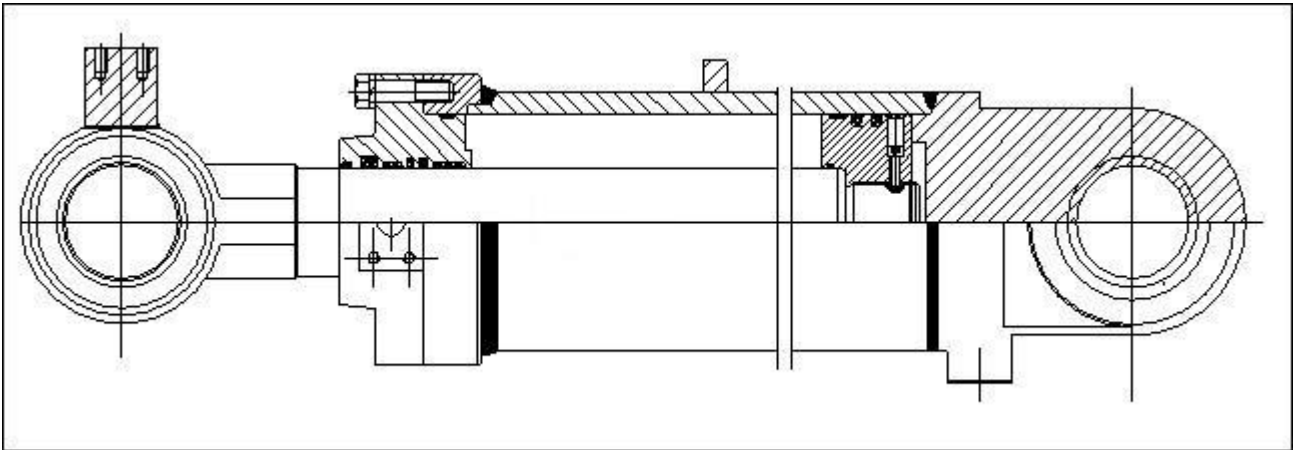

Figure 1

Detailed list of spare parts

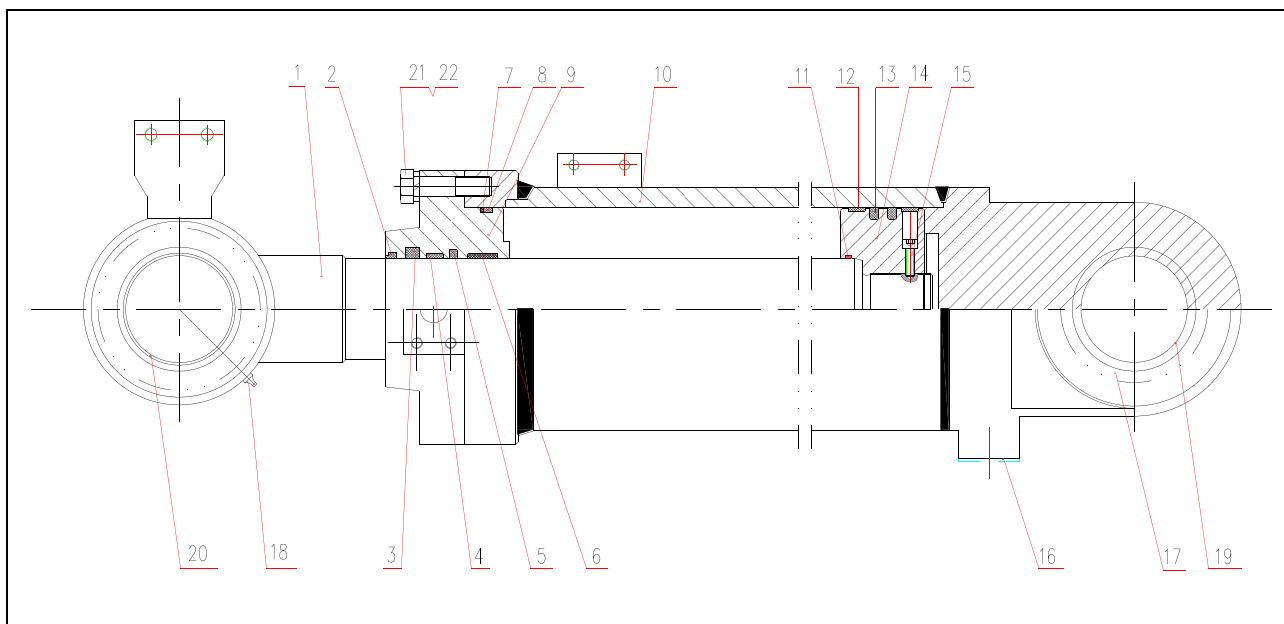

Figure 2

Reference Number	Description	Reference Number	Description
1	Cylinder rod	12	Support ring
2	Dust ring	13	SPGO
3	Obturating ring	14	Piston
4	Support ring	15	Socket head cap screw
5	Cushion seal	16	Port protecting cover
6	Support ring	17	Hole protecting cover
7	Four fluorine block circle	18	Oil cup
8	O-RING	19	Cylinder end bush
9	Guide sleeve	20	Bush
10	Cylinder block	21	Bolt
11	O-RING	22	Washer

Disassembling and assembling steps

Disassembling steps

Note: Prepare a container which can store all hydraulic oil of the maintained cylinder, hydraulic oil will flow out from cylinder.

1. Put the cylinder on special supporting vertically, screw down bolts of cylinder cover with pneumatic wrench or torque wrench.



Figure 3

2. Hang piston rod assembly out from cylinder and put it on special protective support.



Figure 4

3. Twist piston lock screw with special tools.

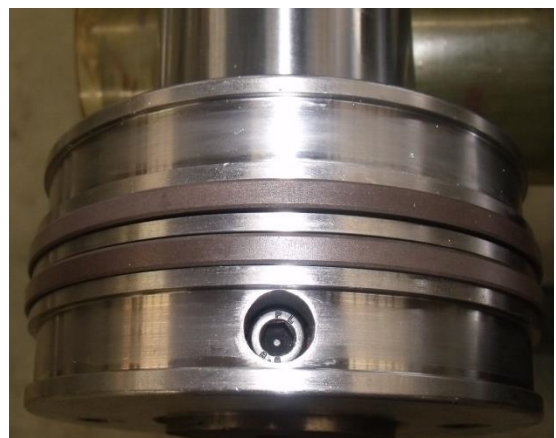

Figure 5

4. Dismantle piston with special piston tightening tool and jackhammer.



Figure 6

5. Dismantle piston and cylinder cover assembly.



Figure 7

6. Dismantle sealing parts with special tools.



Figure 8

Assembling steps

1. Install sealing parts of cylinder.

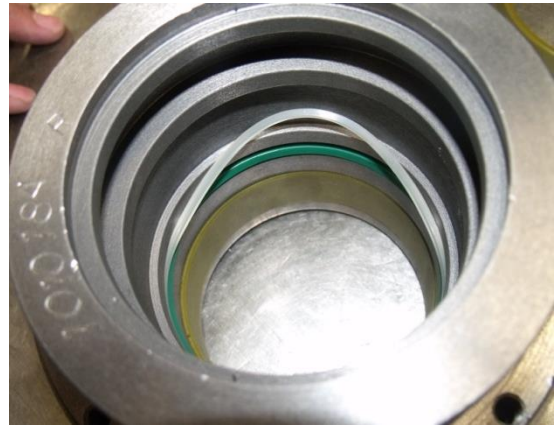

Figure 9

2. Install cylinder cover assembly.



Figure 10

3. Install piston with special tools.



Figure 11

4. Screw down piston bolts with special tools.

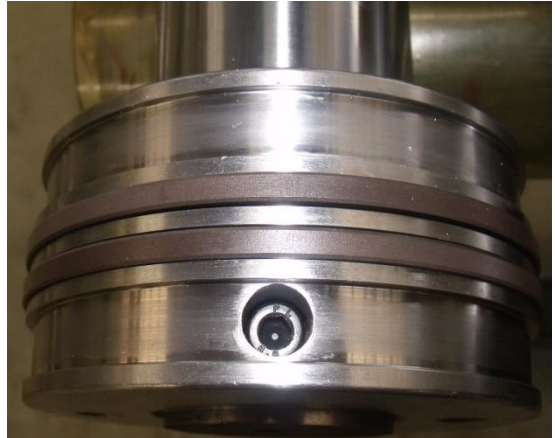

Figure 12

5. Put piston rod in cylinder barrel.



Figure 13

6. Screw down bolts of cylinder cover and cylinder barrel.



Figure 14

Main Pump

CAUTION!

Follow all safety recommendations and safe shop practices outlined in the front of this manual or those contained within this section.

Always use tools and equipment that is in good working order.

Use lifting and hoisting equipment capable of safely handling load.

Remember, that ultimately safety is your own personal responsibility.

TABLE OF CONTENTS

General Description.....	3
Work principle.....	3
Detailed List of Spare Parts.....	4
Parts Replacement principle.....	5
Preparation before Disassembling.....	5
Disassembly and Assembly Steps.....	6

General description

Work principle

Function of main pump is to convert mechanic energy of diesel into pressure energy of working liquid. Main pump is a kind of hydraulic pump with simple structure and wide application, it has small size, light weight, reliable work, low cost and not too sensitive to hydraulic oil, convenient for maintenance and repair, and therefore it is widely applied in hydraulic system of loaders.

Main pump has many types, according to different pressure grade, it can be divided into four types which are: low pressure ($P < 2.5\text{MPa}$), medium pressure ($P > 2.5\text{—}8\text{MPa}$), mesohigh pressure ($P > 8\text{—}16\text{MPa}$) and high pressure ($P > 16\text{—}31.5\text{MPa}$). At present, mesohigh pressure main pumps are used often for loaders. According to difference of gear mesh form, it can be divided into main pump with external mesh and main pump with internal mesh. Of which main pumps with external mesh are more popular.

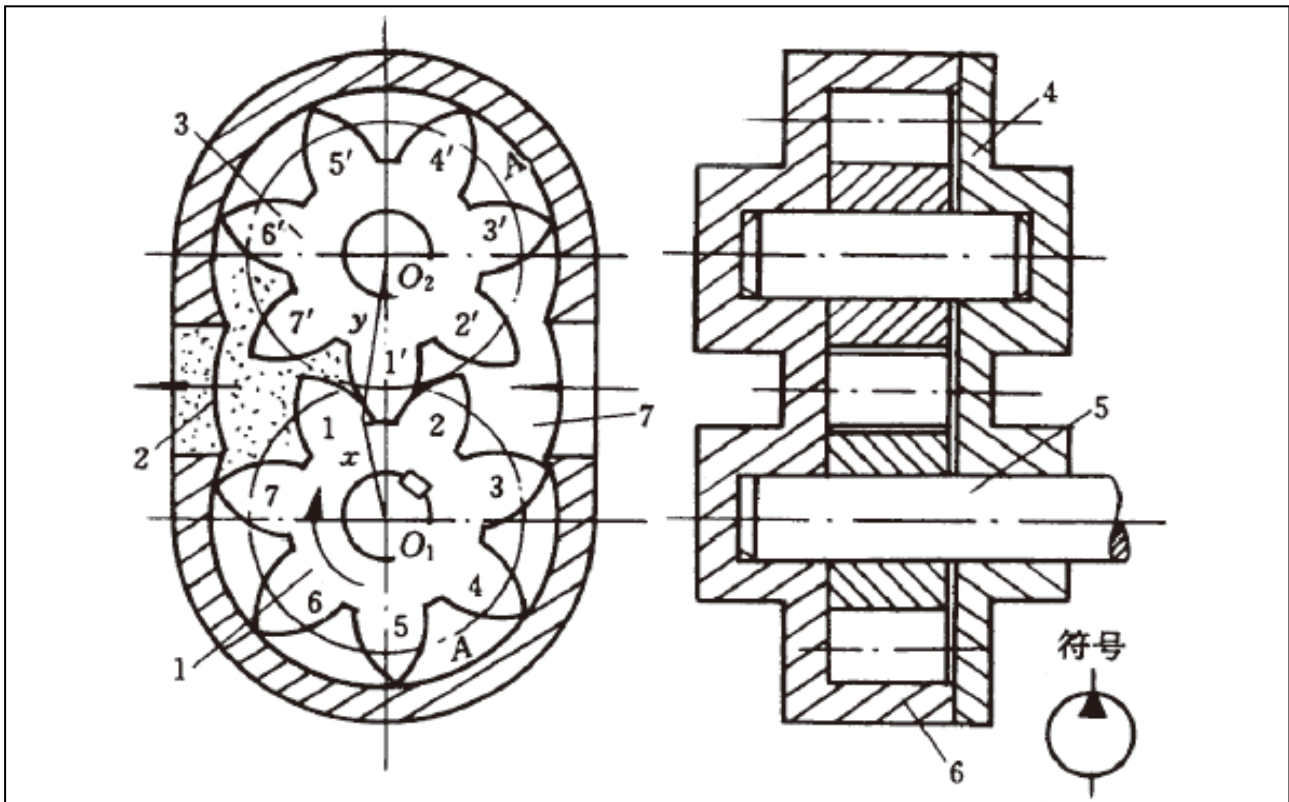

Figure 1

- | | | | | |
|-----------------|----------------------|----------------|------------|-----------------------|
| 1. Driving gear | 2. Extrusion chamber | 3. Driven gear | 4. End cap | 5. Transmission shaft |
| 6. Pump body | 7. Suction chamber | | | |

Detailed list of spare parts

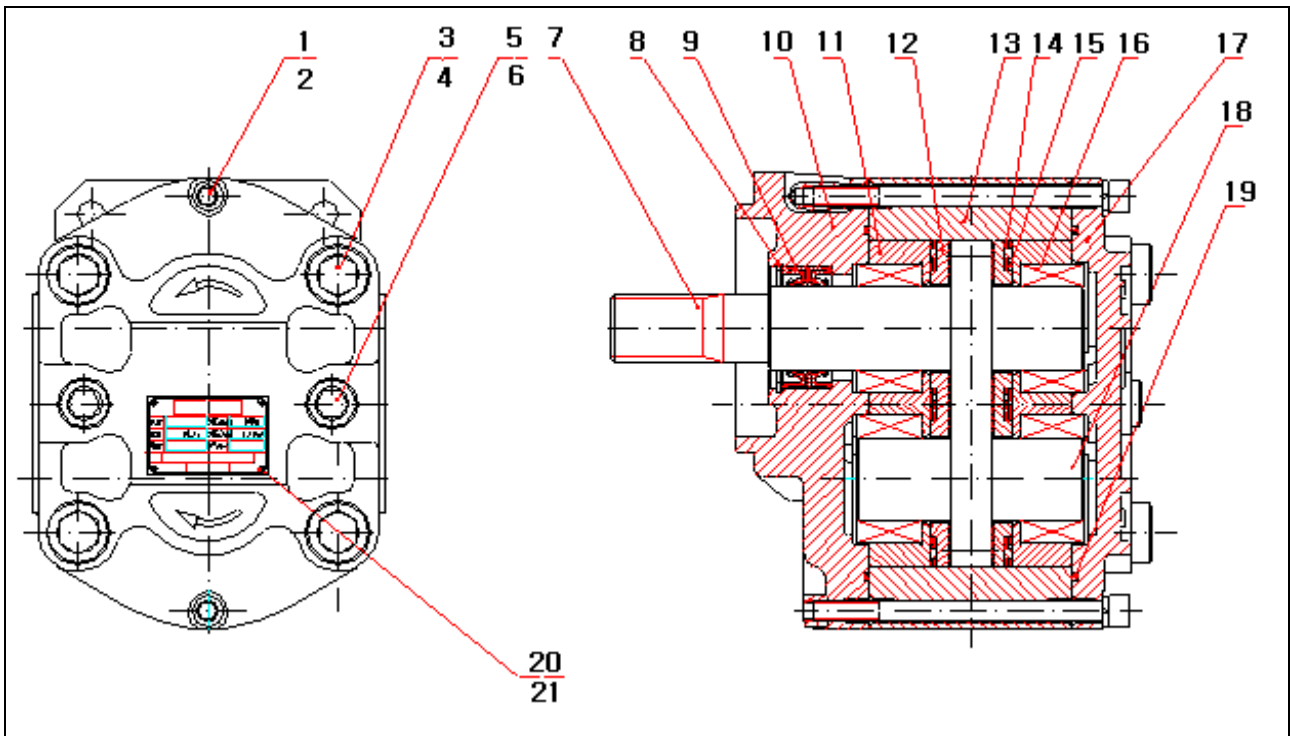

Figure 2

Reference Number	Description	Reference Number	Description
1	BOLT	12	Side Plate
2	WASHER	13	Pump Block
3	BOLT	14	Seal Ring
4	WASHER	15	Block
5	BOLT	16	Needle Roller
6	WASHER	17	Rear Cover
7	Drive Gear	18	Driven Gear
8	Snap Ring	19	Seal Ring
9	Oil Seal	20	Label
10	Front Cover	21	Screw
11	Fixing Cover		

Parts replacement principle

If main pump needs to be repaired to reach the original performance index, parts replacement principle must be followed to replace parts, following is the detailed replacing rules:

1. Side plate: replace side plate when it is scratched, there is pit, spray and finishing layer sheds, burnt, deformed and cavitations corrosion.
2. Gear: replace gear when one of the following conditions happens: shaft diameter of gear shaft is scratched or worn in sealing zone; teeth surface of gear is worn, scratched, broken or deformed; addendum circle is damaged seriously; multiple spline or flat key and spindle nose are worn, deformed and broken.
3. Castings (front cover, pump body, and rear cover):
 - 3.1 If there is flaw on castings, and sealing zone has chip, rust, deformed pin hole, then replace castings.
 - 3.2 Replace pump body when one of the following conditions happens: oil mouth is broken, pump body is broken and rusty; when bore depth of pump body $>0.08\text{mm}$.
4. Round pin: round pin must be replaced when the matching does not comply with requirements, pin is broke and deformed, replace the front cover, pump body and rear cover matched with round pin when it is necessary.
5. Rolling bearing: new parts must be replaced when quill roller drops, retainer is damages, quill roller has surface pitting, roller path has surface pitting, over sintering.
6. Second sealing ring: replace with new parts when there is inner diameter abrasion, end face abrasion, thickness is milled, deformed, surface is coarse.
7. Non-metal sealing parts: all non-metal sealing parts must be replaced.
8. Outboard bearing: replace with new parts when parts are worn and rusty.
9. Fastener: replace it when it is drawn out, deformed and damaged.

Preparation before disassembling

1. Clean the surface of pump, and check if the surface has chip and rust.
2. Check model and factory releasing number on nameplate, if there is no nameplate on pump, check factory releasing number at seam allowance of front cover.
3. Fill in relative information on main pump returned for maintenance card before disassembling, such as manufacturer, applicable machine model, applicable working condition, pump model, factory releasing number, factory releasing date, head and marks of fabricator, working parameters (pressure, rotation, impact and the constant running time at the highest pressure) on main machine, total working time of main pump and reason for returning for maintenance, etc.
4. Make sure the production is released from the factory as a whole and it is not disassembled after releasing, otherwise it is not maintained.
5. If there is external leaking, do gas tightness checking to the entire pump and find out leaking position.
6. Check tightening torque of bolts (screw down bolts again with torque wrench, record the Max. tightening torque), learn if tightening torque of all bolts have reached the required specification.

Disassembly and assembly steps

Disassembly steps

1. Dismantle front end cap.

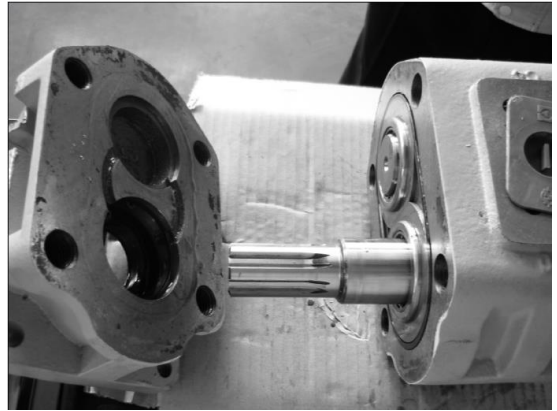

Figure 3

2. Dismantle jump ring with jump ring pincer.

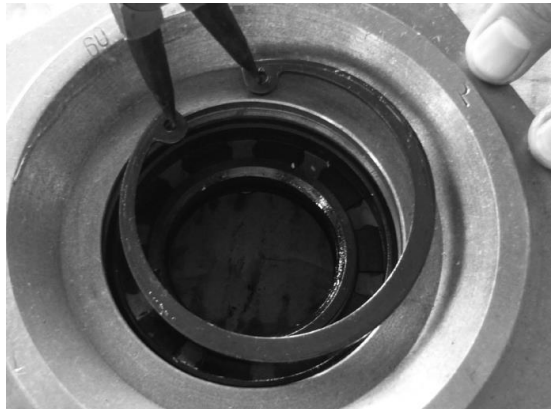

Figure 4

3. Take out framework oil seal.



Figure 5

4. Take out support wire.

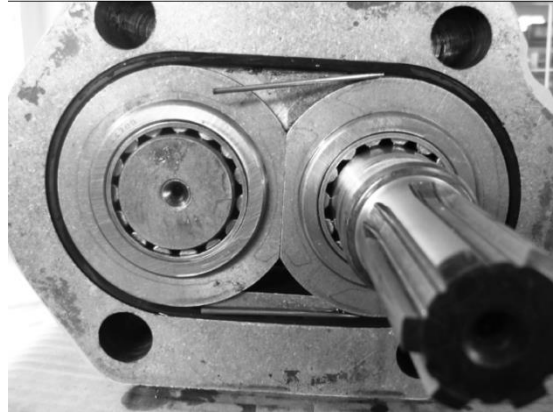

Figure 6

5. Dismantle sealing ring.

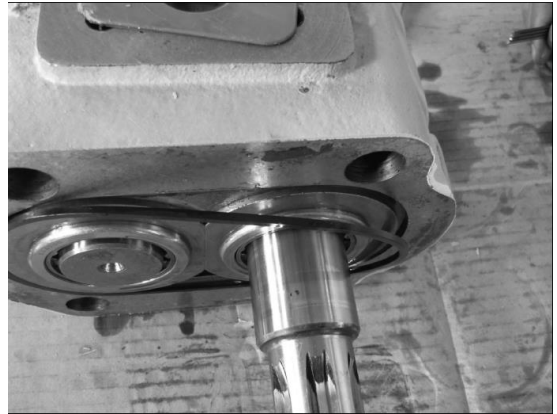

Figure 7

6. Dismantle bearing.



Figure 8

7. Dismantle front ear type sealing ring



Figure 9

8. Dismantle ear type sealing ring.



Figure 10

9. Dismantle side plate.



Figure 11

10. Dismantle driven gear.



Figure 12

11. Dismantle active gear.

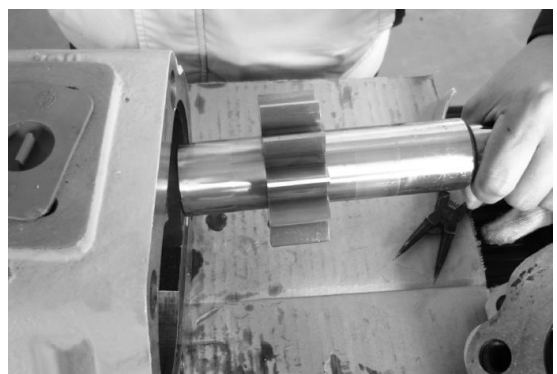

Figure 13

12. Dismantle rear cover bolts.

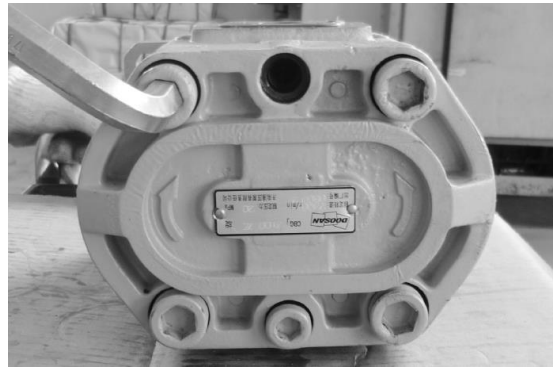

Figure 14

13. Dismantle rear cover.



Figure 15

14. Dismantle wire of lower limitation.



Figure 16

15. Dismantle sealing ring.

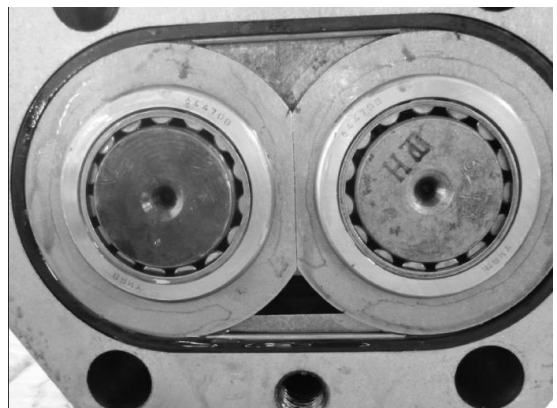

Figure 17

Main Pump

SPC000042

16. Dismantle bearing.

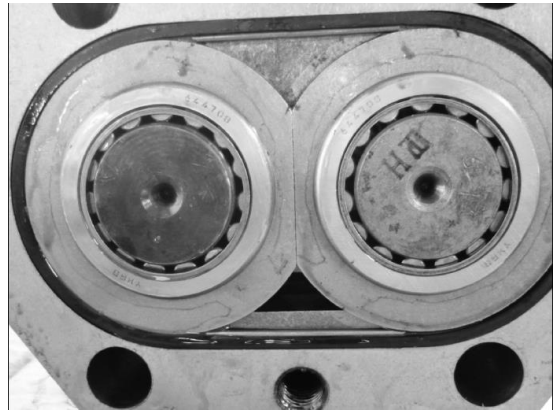

Figure 18

Installation steps

1. Install bearing.

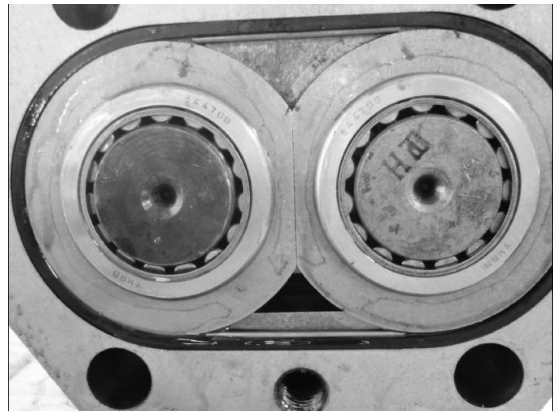

Figure 19

2. Install sealing ring.

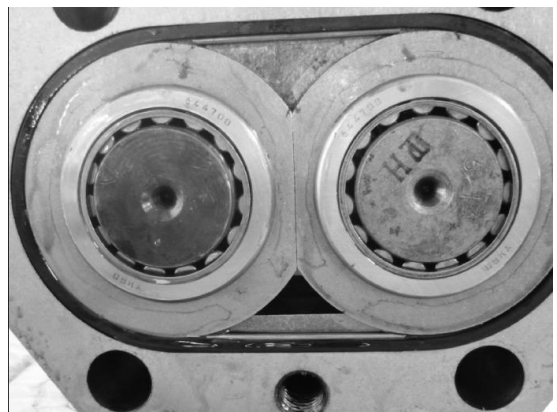

Figure 20

3. Install limitation wire.

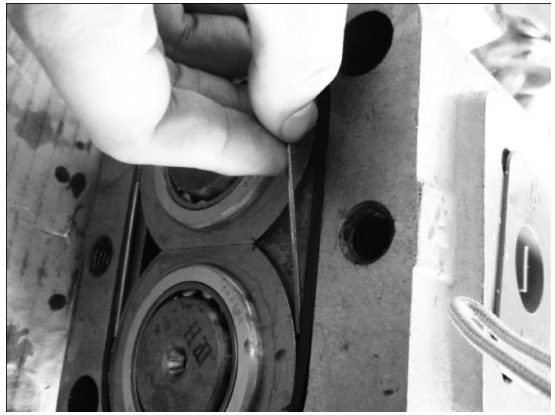

Figure 21

4. Install rear cover.

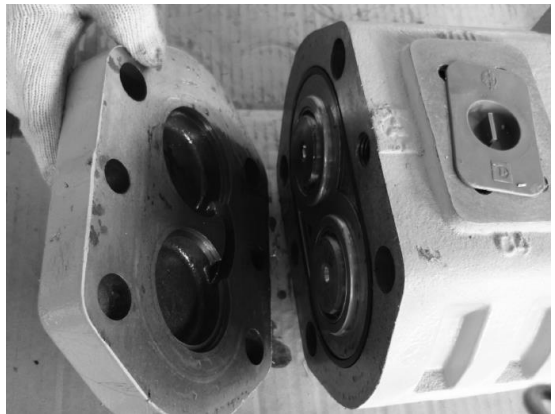

Figure 22

5. Install rear cover bolts.



Figure 23

6. Install active gear.



Figure 24

7. Install driven gear.



Figure 25

8. Install side plate.



Figure 26

9. Install ear type sealing ring.



Figure 27

10. Install front ear type sealing ring.



Figure 28

Main Pump

SPC000042

Page 12

11. Install bearing.



Figure 29

12. Install sealing ring.



Figure 30

13. Install support wire.

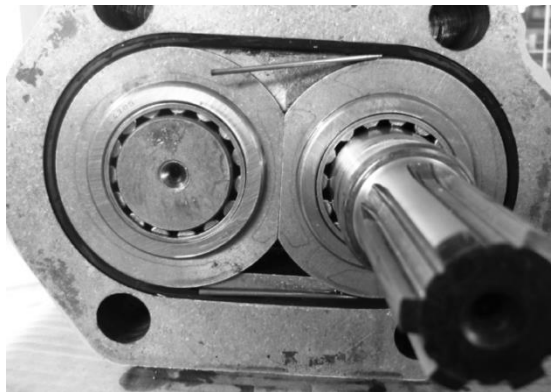

Figure 31

14. Install framework oil seal.



Figure 32

Main Pump

15. Install jump ring with jump ring pincer.

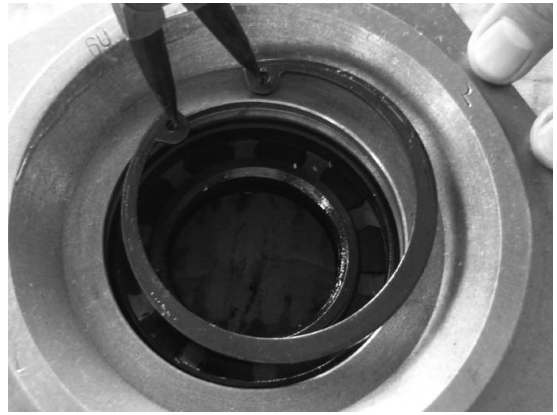

Figure 33

16. Install front end cover.

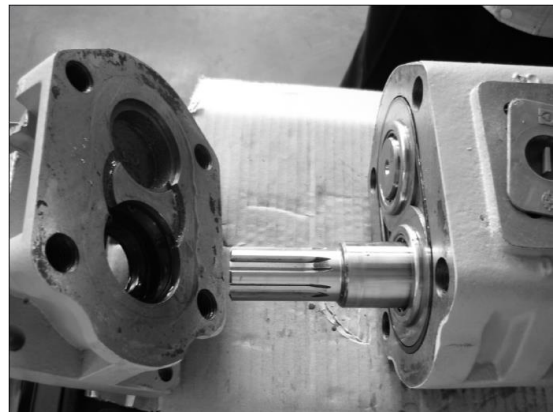

Figure 34

Note:

1. Clean parts with cleaning agent, do not use rag to avoid remaining any clothing fiber.
2. Slide touching parts and bearing, coating with hydraulic oil and assemble after cleaning.
3. Replace O ring and sealing parts with new ones:

Disassembling order: front cover →framework oil seal→ O ring →bearing →sealing ring →side plate
→driven gear →active gear →rear cover →O ring →bearing.

Assembling order: bearing →O ring →rear cover→ active gear→ driven gear→ side plate →sealing
ring→ bearing→ O ring→ framework →framework oil seal→ front cover.

Steer Pump

 CAUTION!

Follow all safety recommendations and safe shop practices outlined in the front of this manual or those contained within this section.

Always use tools and equipment that is in good working order.

Use lifting and hoisting equipment capable of safely handling load.

Remember, that ultimately safety is your own personal responsibility.

TABLE OF CONTENTS

General Description.....	3
Work principle.....	3
Detailed List of Spare Parts.....	4
Parts Replacement Principle.....	5
Preparation before Disassembling.....	5
Disassembly and Assembly Steps.....	6

GENERAL DESCRIPTION

Work principle

When active gear 4 rotates with clockwise direction, driven gear 10 rotates with anti-clockwise direction, partial vacuum is formed when teeth of two gears are away from the area in oil in side (left area shown in the figure), with effect of atmospheric pressure, hydraulic oil enters oil suction chamber of oil pump and fills in teeth area. At the other oil outlet side, the size is smaller because of gear mesh, hydraulic oil is squeezed out, gear keeps rotating, gear teeth keeps squeezing out hydraulic oil to enter into work oilway and realize constant oil supplying of the system.

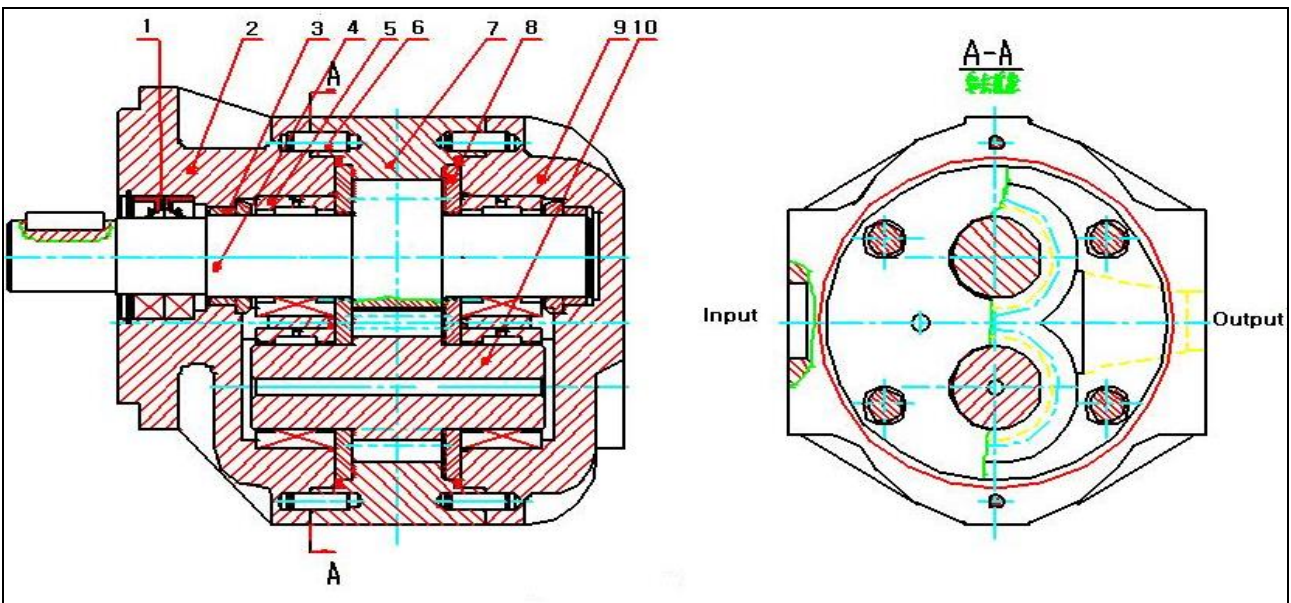

Figure 1

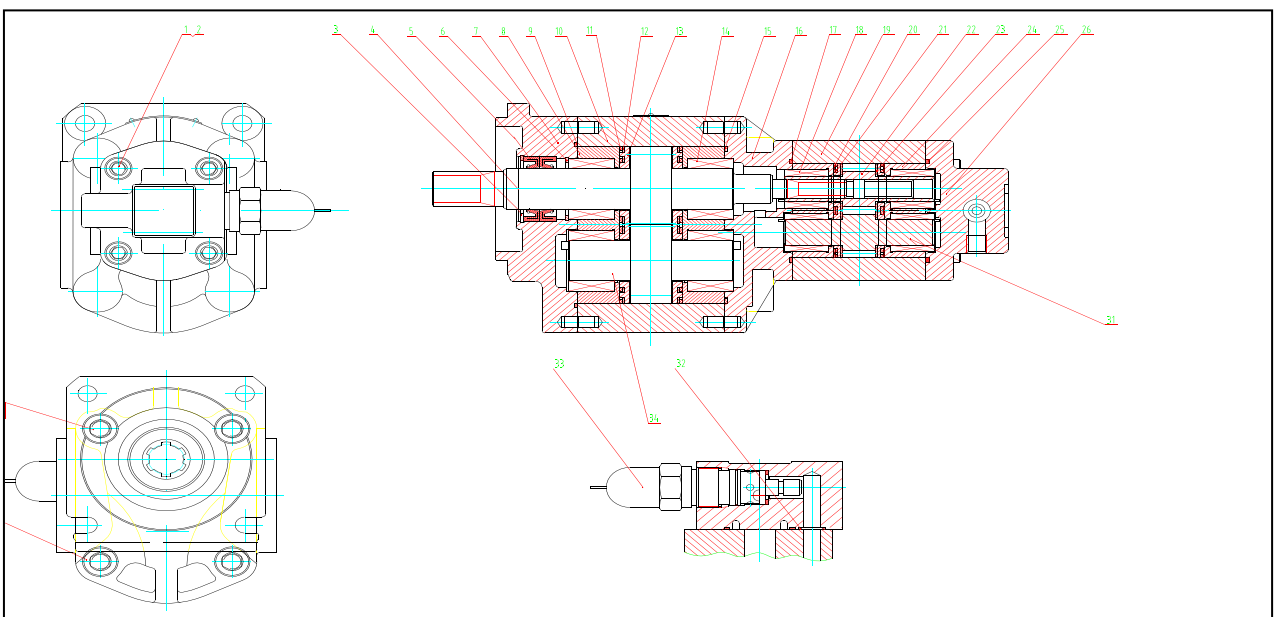

Figure 2

Steer Pump

SPC000043

Page 3

PARTS LIST

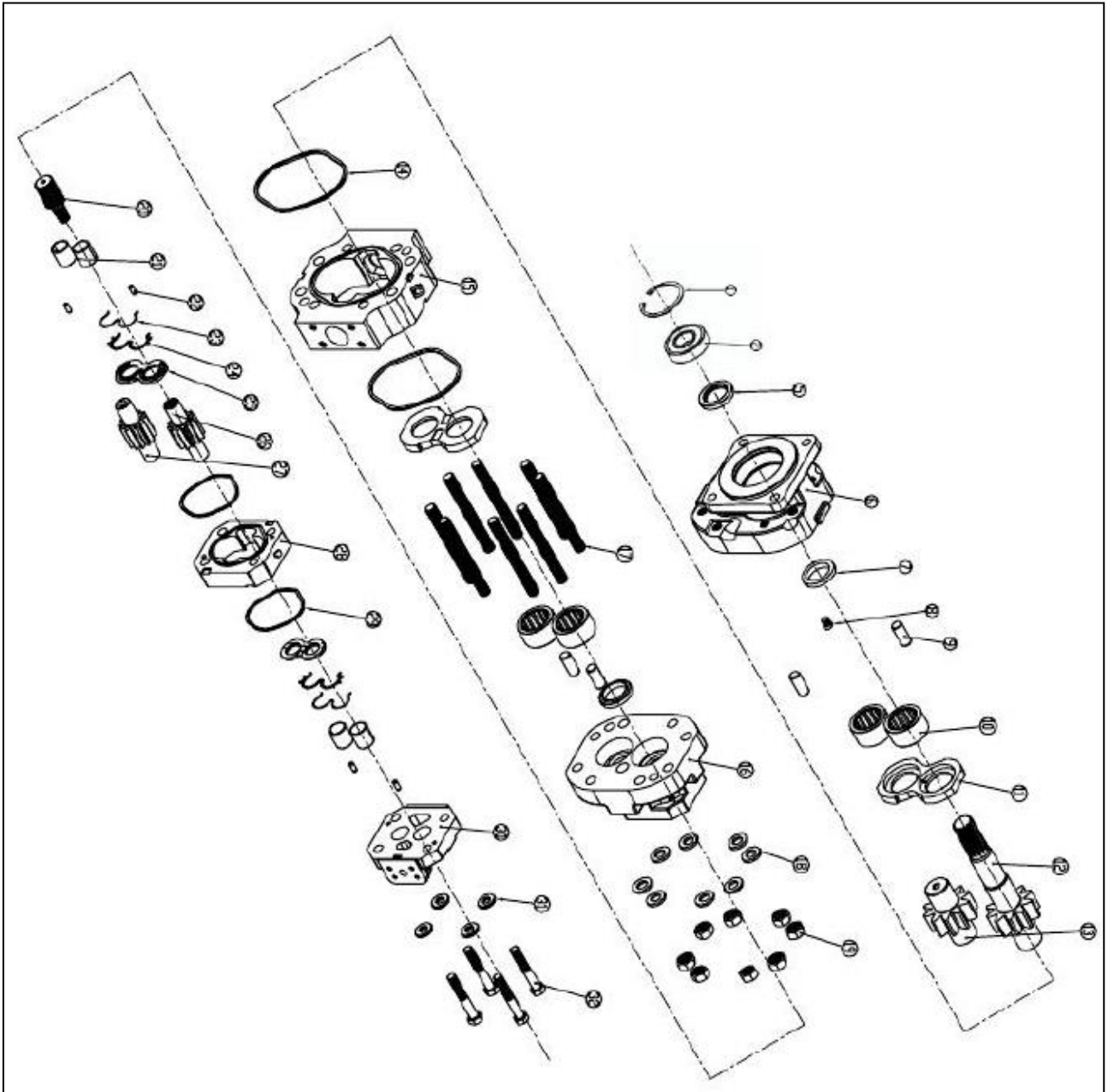

Figure 3

Number	Description	Number	Description
1	Elastic Baffle Ring	18	Gasket
2	External Roller Bearing	19	Hexnut
5	Framework Oil Seal	20	Connectiong Shaft
6	Front Cover	21	Sliding Bearing
7	Secondary Sealing Ring	22	Column Pin
8	Oil Plug Bolt	23	E Shape Baffle Ring
9	Column Pin	24	E Shape Sealing Ring
10	Quill Roller	25	Side Plate
11	Side Plate	26	Second Grade Active Gear
12	First Grade Active Gear	27	Second Grade Driven Gear
13	First Grade Driven Gear	28	Rear Pump Body
14	Square Sealing Ring	29	Square Sealing Ring
15	First Grade Pump Body	30	Rear Cover
16	Intermediate Body	31	Gasket
17	Double-screw bolt	32	Hexagon-headed Bolt

Parts replacement principle

If main pump needs to be repaired to reach the original performance index, parts replacement principle must be followed to replace parts, following is the detailed replacing rules

1. Side plate: replace side plate when it is scratched, there is pit, spray and finishing layer sheds, burnt, deformed and cavitation corrosion.
2. Gear: replace gear when one of the following conditions happens: shaft diameter of gear shaft is scratched or worn in sealing zone; teeth surface of gear is worn, scratched, broken or deformed; addendum circle is damaged seriously; multiple spline or flat key and spindle nose are worn, deformed and broken.
3. Castings (front cover, pump body, and rear cover)
 - 3.1 If there is flaw on castings, and sealing zone has chip, rust, deformed pin hole, then replace castings.
 - 3.2 Replace pump body when one of the following conditions happens: oil mouth is broken, pump body is broken and rusty; when bore depth of pump body $>0.08\text{mm}$.
4. Round pin: round pin must be replaced when the matching does not comply with requirements, pin is broke and deformed, replace the front cover, pump body and rear cover matched with round pin when it is necessary.
5. Rolling bearing and sliding bearing
 - 5.1 Rolling bearing: new parts must be replaced when quill roller drops, retainer is damages, quill roller has surface pitting, roller path has surface pitting, over sintering.
 - 5.2 Sliding bearing: if one of the following conditions happens, bearing must be replaced: bearing surface is scratched, painting coat sheds, or copper basement is exposed.
6. Secondary sealing ring: replace with new parts when there is inner diameter abrasion, end face abrasion, thickness is milled, deformed, surface is coarse.
7. Non-metal sealing parts: all non-metal sealing parts must be replaced.
8. Outboard bearing: replace with new parts when parts are worn and rusty.
9. Fastener: replace it when it is drawn out, deformed and damaged.

Preparation before disassembling

1. Clean the surface of pump, and check if the surface has chip and rust.
2. Check model and factory releasing number on nameplate, if there is no nameplate on pump, check factory releasing number at seam allowance of front cover.
3. Fill in relative information on main pump returned for maintenance card before disassembling, such as manufacturer, applicable machine model, applicable working condition, pump model, factory releasing number, factory releasing date, head and marks of fabricator, working parameters (pressure, rotation, impact and the constant running time at the highest pressure) on main machine, total working time of main pump and reason for returning for maintenance, etc.
4. Make sure the production is released from the factory as a whole and it is not disassembled after releasing, otherwise it is not maintained.
5. If there is external leaking, do gas tightness checking to the entire pump and find out leaking position.
6. Check tightening torque of bolts (screw down bolts again with torque wrench, record the Max. tightening torque), learn if tightening torque of all bolts have reached the required specification.

Disassembly and assembly steps

Disassembly steps

1. Draw two crossed making line from rear cover, pump body to front cover (this line will play the guiding role during assembling). Keep seam allowance of front cover of the pump down war, fix it on work platform or bench clamp.



Figure 4

2. Measure fastening torque (fastening torque is 163N.m) of the secondary pump (P124) with torque wrench and record. Loosen the secondary pump bolts with manual or pneumatic wrench.



Figure 5

3. Insert screwdriver in opening mouth, separate rear cover and rear pump body (do not damage combination surface). Check carefully; confirm if rear cover and sliding bearing shall be replaced according to parts replacement principle.



Figure 6

4. Take out side plate assembly from rear pump body (mark well), check carefully if parts need to be replaced according to parts replacement principle.



Figure 7

5. Take out secondary active gear axle and driven gear axle from pump body, mark well when driven gear is taken out to avoid reverse driven gear during assembling. Confirm if gear shall be replaced according to parts replacement principle.



Figure 8

6. Take out column pin and side plate assembly (mark well on side plate), check carefully and confirm if part shall be replaced according to parts replacement principle.



Figure 9

7. Insert screwdriver in opening mouth slightly (do not damage combination surface), take out square sealing ring and discard as useless. Replace pump body according to parts replacement rules.

Note: *Sealing condition of chamber of pump body, sealing surface of oil inlet and outlet, matching of column pin, sealing condition of square sealing ring.*



Figure 10

8. Check intermediate body, sliding bearing (pointed by arrowhead) of rear cover, confirm if they shall be replaced according to parts replacement principle.



Figure 11

9. Measure fastening torque (fastening torque is 271N.m) of the first pump (P5100) with torque wrench and record. Loosen the first pump bolts with manual or pneumatic wrench.



Figure 12

10. Open intermediate body.



Figure 13

11. Dismantle double-screw bolt with screwdriver.
Take out connection shaft of main gear.



Figure 14

12. Take out active gear and driven gear from pump body, mark well when driven gear is taken out to avoid reverse driven gear during assembling. Do not strain oil seal when taking out active gear. Confirm if gear shall be replaced according to parts replacement principle

Note: *Abrasion and damage condition of gear mesh, and matching position between gear and gear axle.*



Figure 15

13. Take out pump body with screwdriver slightly (do not damage combination surface), take out square sealing ring and discard it as useless. Confirm if pump body shall be replaced according to parts replacement principle.

Note: *Sealing condition of chamber of pump body, sealing surface of oil inlet and outlet, matching of column pin, sealing condition of square sealing ring.*

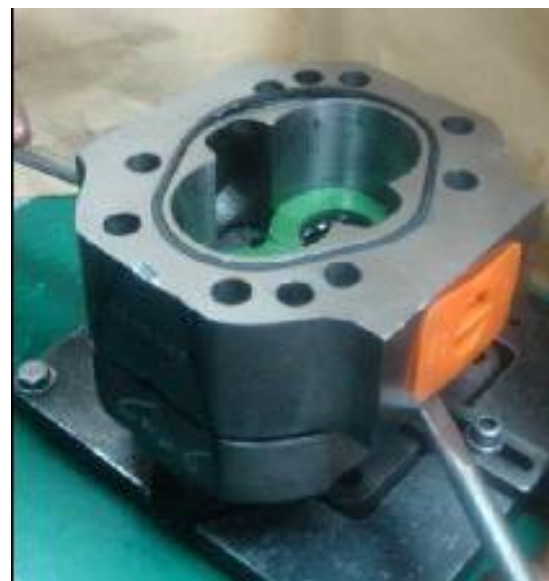

Figure 16

14. Take out quill roller from front cover and intermediate body with bearing disassembling frock, confirm if bearing shall be replaced according to parts replacement principle. If quill roller is not damaged, this step can be omitted.

Note: *Column pin can be taken out at any moment during disassembling process.*



Figure 17

15. Take out secondary sealing ring of front cover and intermediate body, confirm if secondary sealing ring shall be replaced according to parts replacement principle.

Note: *Abrasion condition of inner hole surface and end surface of sealing ring.*



Figure 18

16. Keep seam allowance of front cover upward, fix it on work platform, take out elastic baffle ring with circlip plier.



Figure 19

17. Take out external bearing sleeve, confirm if it shall be replaced according to parts replacement rules.



Figure 20

18. Reverse front cover, knock out oil seal from, oil seal shall be discarded as useless.



Figure 21

Disassembling steps of double pump

1. Place the double pump on assembly table in a horizontal position.



Figure 22

2. Disassembly the overflow valve with adjustable wrench .



Figure 23

3. Fix double pump well, remove the back cover bolt.



Figure 24

4. Remove the small pump body and put as shown.



Figure 25

5. Fix double pump well, remove the front cover bolt.



Figure 26

6. Disassembly the double pump intermediate and place in a horizontal position.



Figure 27

7. knock the small pump gear shaft end with rubber leather cushion, Disassembly the side plate, and other small parts. Reverse knock on the other side and remove the side plate and gear.



Figure 28

8. remove shaft sleeve side plate of the large pump and master-slave dynamic gear shaft in the same way.

According to the order from 8 to 1 to assemble the double pump

Assembling steps

Assembling of front cover assembly

1. Keep larger surface of front cover downward, coat anaerobic sealant on oil seal outer ring and press it in front cover oil seal directly with special tools (keep mouth downward).



Figure 29



Figure 30

2. Press into external bearing.



Figure 31

Steer Pump

3. Install hole applicable elastic baffle ring into baffle ring groove.

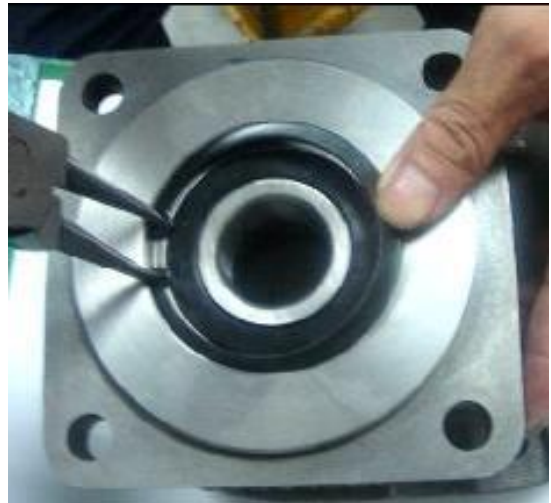

Figure 32

4. Turn around front cover, keep larger surface of front cover upward, install the secondary sealing ring in bearing hole of active and driven bearing, keep the surface downward and the contact surface shall be flat.



Figure 33

5. Press two quill rollers into bearing holes.



Figure 34

6. If new front cover is applied, assembly is the same as mentioned above.

Note: *if there are double oil discharging holes on front cover, block oil discharging hole of high pressure zone with oil screw plug (coat thread sealant on thread).*



Figure 35

Assembling of intermediate body assembly

Keep smaller surface of intermediate body upward, put two sliding bearings into bearing holes.

Note: *Mouth of sliding bearing shall toward the position pointed with arrowhead (refer to assembling of rear cover assembly). If intermediate sliding bearing is damaged, then replace the damaged bearing, if there is no damage, this step is omitted.*

Note: *Requirements of assembling of the secondary sealing ring of intermediate body and quill roller are the same with assembling requirements of front cover assembly.*



Figure 36

Assembling of rear cover assembly

Keep the flat surface of rear cover upward, press two sliding bearings into bearing holes.

Note: *Mouth of sliding bearing shall toward the position pointed with arrowhead (refer to assembling of rear cover assembly). If intermediate sliding bearing is damaged, then replace the damaged bearing, if there is no damage, this step is omitted.*



Figure 37

Assembling of side plate assembly

Install E shape sealing ring and E shape baffle ring in sealing groove of side plate, coat little molybdenum disulfide grease.

Note: *E shape baffle ring cannot prolapse from groove.*



Figure 38

Assembling of gear pump assembly

Note that the straight line marked on front cover, the first pump, the second pump, intermediate pump body and rear cover shall align; assemble according to the marked position on driven gear and side plate.

1. Check combination surface of front cover, pump body, intermediate body and rear cover, remove the higher points with plane oilstone. Get rid of stone mill.



Figure 39

2. Install side plate on front cover, keep the painting surface upward, and knock with rubber hammer symmetrically.

Note: *Assemble according to the marked position of side plate.*



Figure 40

3. Install two location pins, first grade active gear and driven gear.

Note: Assemble according to the marked position of gears.



Figure 41

4. Install square sealing ring

Note: Coat little molybdenum disulfide grease on square sealing ring.



Figure 42

5. Keep the surface of pump body with square sealing ring downward when installing the first pump body.



Figure 43

6. Install square sealing ring on pump body.

Note: Coat little molybdenum disulfide grease on square sealing ring.



Figure 44

7. Inject hydraulic oil (used for starting lubrication).

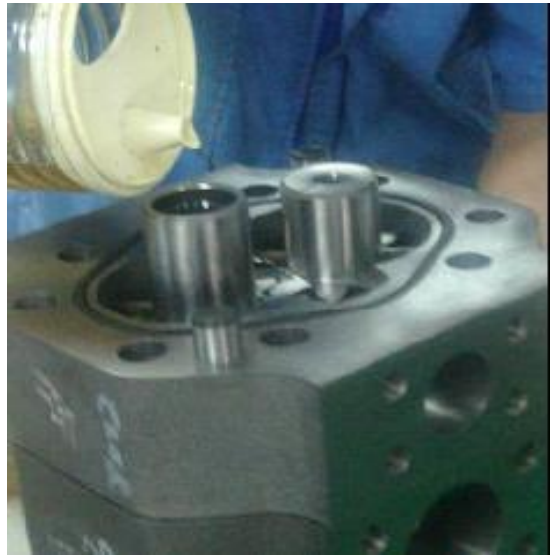

Figure 45

8. Install connecting shaft, column pin and double screw bolts, twist bolts with screwdriver.



Figure 46

9. Install intermediate body assembly.



Figure 47

10. Install the first pump gasket and screws, fasten screws from opposite angles, fastening torque is 271N.m.



Figure 48

11. Install locating pin.



Figure 49

12. Install square sealing ring on the secondary pump body.

Note: Coat little molybdenum disulfide grease.



Figure 50

13. Install the secondary pump body.

Note: Keep the surface of pump body with square sealing ring downward.



Figure 51

14. Install front side plate assembly.

Note: Assemble according to marked position of side plate.



Figure 52

15. Install the second grade active gear and driven gear.

Note: Assemble according to marked position of driven gear.



Figure 53

16. Inject hydraulic oil (used for starting lubrication).



Figure 54

17. Install rear side plate assembly and square sealing ring.

Note: Assemble according to marking position of side plate. Coat little molybdenum disulfide grease on square sealing ring.



Figure 55

18. Column pin.



Figure 56

19. Rear cover assembly.



Figure 57

20. Install the secondary pump gaskets and bolts, fasten bolts from opposite angle, fastening torque is 163N.m.



Figure 58

21. Plug oil inlet and outlet well and shaft scutching protection sleeve.



Figure 59

Main Control Valve

CAUTION!

Follow all safety recommendations and safe shop practices outlined in the front of this manual or those contained within this section.

Always use tools and equipment that is in good working order.

Use lifting and hoisting equipment capable of safely handling load.

Remember, that ultimately safety is your own personal responsibility.

TABLE OF CONTENTS

General Description.....	3
Schematic Diagram.....	3
Detailed List of Spare Parts.....	4
Disassembly and Assembly Steps.....	8
Basic Faults and Overcoming	10

General description

Schematic Diagram

1. Source: the hydraulic multi-way directional valve is domestic assorting parts for 950B, 966D and 980S wheel loaders introduced in from abroad.
2. Purpose: the valve is combined with DJS pilot valve, mainly used for ZL40, ZL50, ZL60 and other medium and large size loaders, it can also be used for hydraulic system of bulldozers and other medium and large size engineering machines.
3. Characteristics:
 - a. Adopt decompression type pilot valve to control which reduce reversing operating force greatly;
 - b. Improve jogging feature of multi-way valve greatly.
 - c. Relief valve, overload valve, oil compensating valve and check valve adopt plug-in mounting which has good generality and easy for maintenance.
 - d. Four floating is easily realized on the basis of three main valves, which make four main valve structure simple.
 - e. It is convenient for pipe lay out, and reduces pressure loss of the system.
4. Schematic diagram

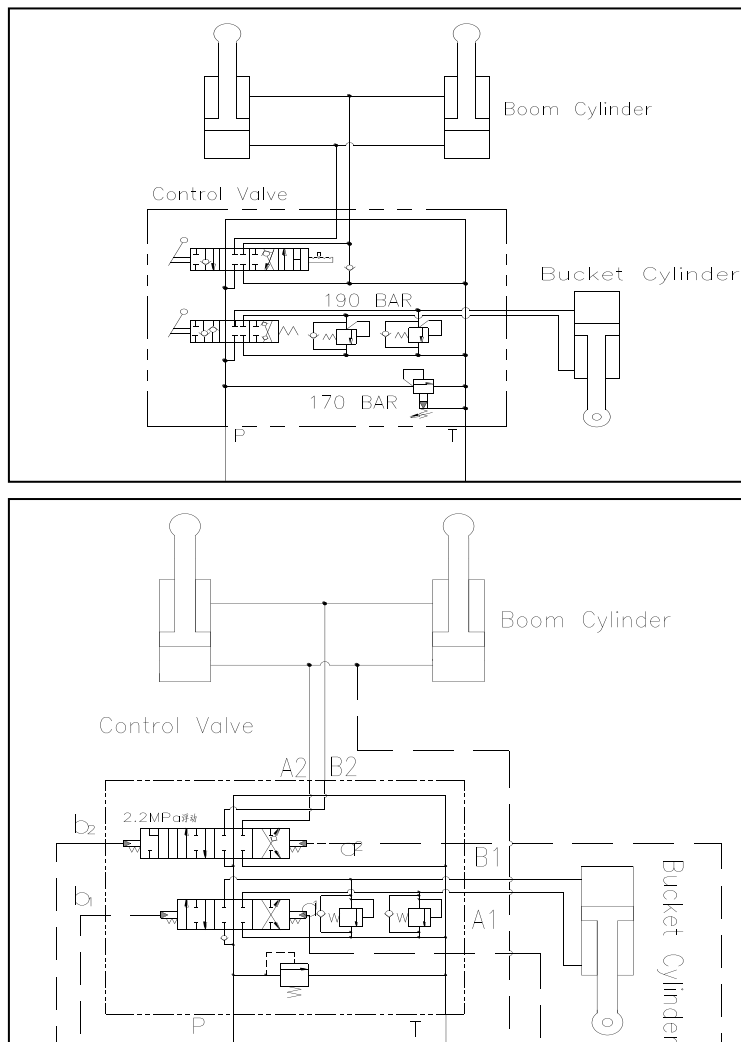

Main Control Valve

Figure 1

SPC000044

Detailed list of spare parts

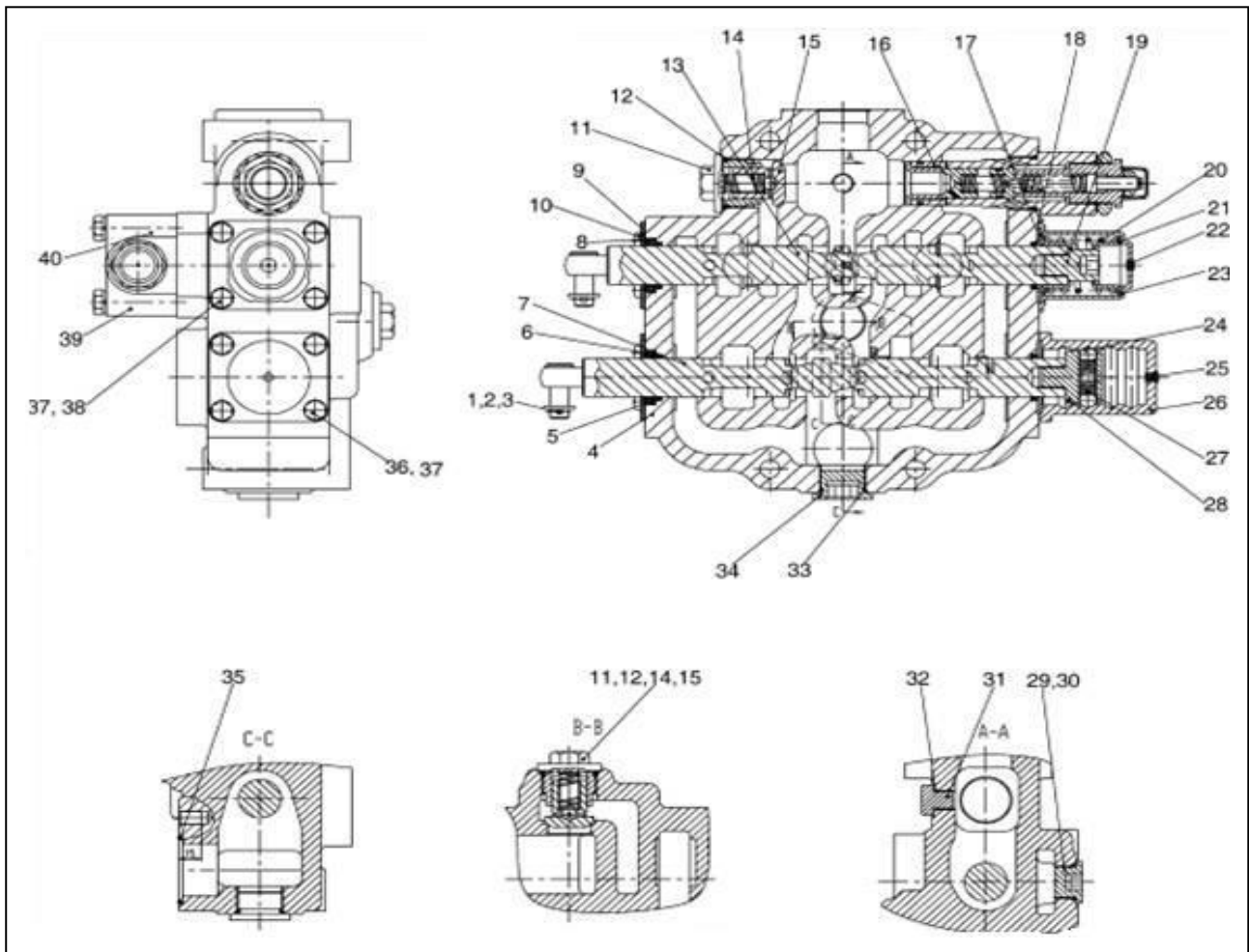

Figure 2

Reference Number	Description	Reference Number	Description
1	PIN,SPLIT	22	PLUG
2	WASHER	23	COVER & STUD ASSY
3	PIN	24	BALL,SQUEEZE
4	BLOCK,VALVE	25	PLUG
5	RING,O	26	COVER & STUD ASSY
6	WASHER	27	SEAT,SPRING
7	STEM	28	SPRING,SEAT
8	RING,DUST	29	RING,O
9	PLATE,PRESSURE	30	NUT,HEX
10	SCREW,TAPPING	31	PLUG,THREADED
11	COVER,VALVE	32	RING,O
12	RING,O	33	NUT,HEX
13	STEM	34	RING,O
14	SPRING	35	BOLT,EYE
15	VALVE,CHECK	36	PAD
16	VALVE,SAFETY	37	BOLT,EYE
17	PIECE,BED	38	VALVE,OVER LOAD RELIEF
18	WASHER,SEAL	39	VALVE ASSY,OVER LOAD RELIEF
19	SEAT,SPRING	40	SEAL KIT;CONTROL VALVE
20	SPRING	41	PLUG
21	SPRING,SEAT		

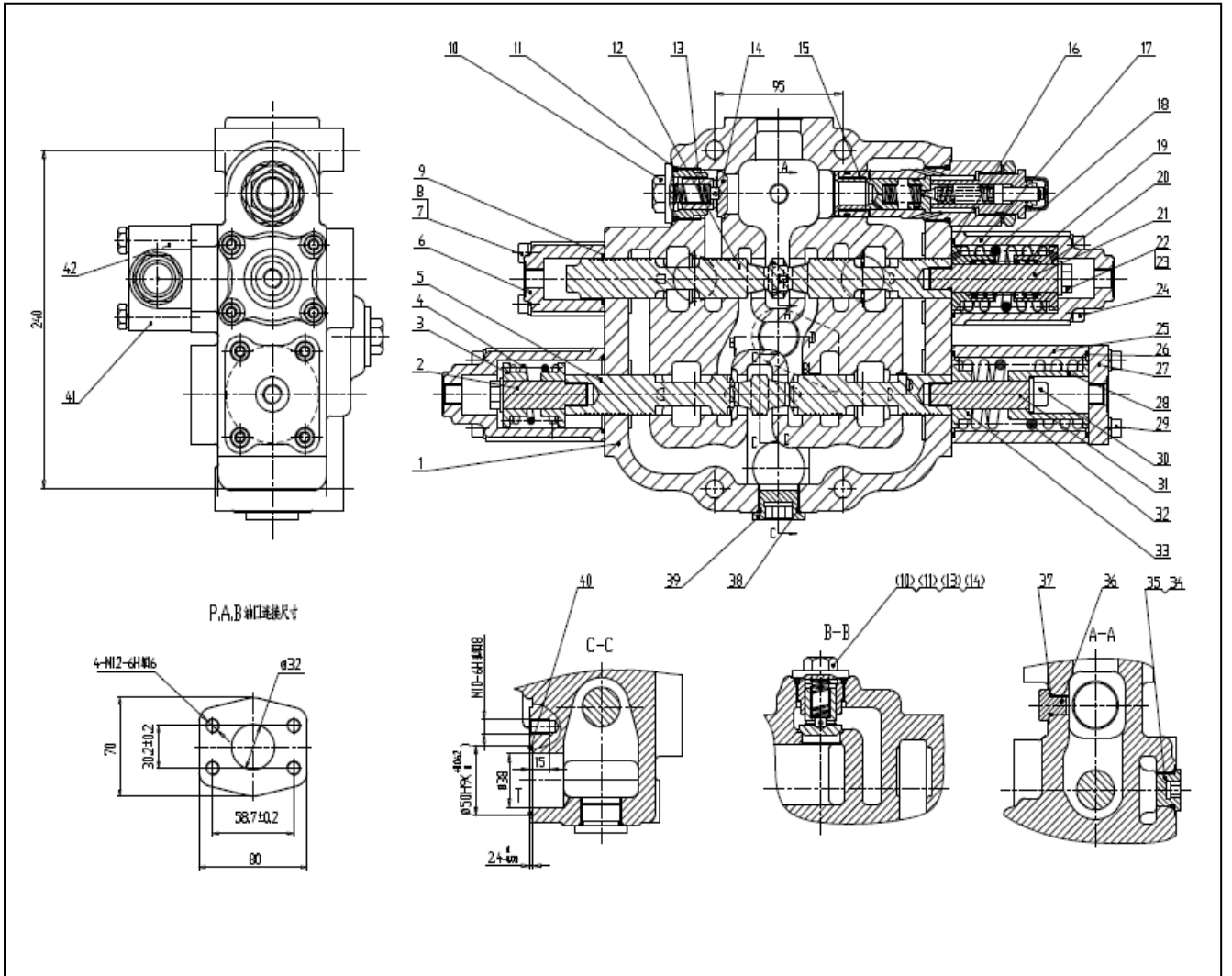

Figure 3

Reference Number	Description	Reference Number	Description
1	Valve body	22	Washer
2	Valve rod joint	23	Bolt M12x20
3	Spring seat	24	Bolt M8x100
4	Spring	25	Sleeve
5	Valve rod	26	O-Ring 50x3.1
6	Cover	27	Gland
7	Bolt M8x65	28	Spring seat
8	Washer	29	Bolt M8x130
9	O-RING 31.5x2.65	30	Bolt M12x20
10	Cover board	31	Valve rod joint
11	O-RING 31.5x3.55	32	Spring
12	Bucket rod	33	Spring seat
13	Spring	34	O-Ring 21.2x2.65
14	One-way valve	35	Plug screw
15	Relief valve	36	Plug
16	O-RING 55x3.1	37	O-Ring 1.8x2.1
17	End cover	38	O-Ring 32x3.1
18	Spring	39	plug screw
19	Spring	40	O-Ring 50x3.1
20	Spring seat	41	Overload valve
21	Valve rod joint	42	Make up valve

Disassembly and assembly steps

Disassembling of GDF-32-00C

1. Disassemble the valve stem and end cover. Take out end cover; Pull stem back and forth, check whether card hysteresis then remove the valve stem. Demolition end cover and pull out the valve stem before cleaning multiple valve and place the valve body on a clean flat place to disassemble. After cleaning end cover, put the stem alignment to the valve hole, slowly assemble the end cover tightening bolts. When moving arm valve lever you should pay attention to the ball. Bolt tightening torque for the two end cover should be 35-40N.m
2. Disassemble the relief valve and overload valve. When remove the relief valve , be careful not to loose overload valve head lock nut, put back to the body after cleaning.

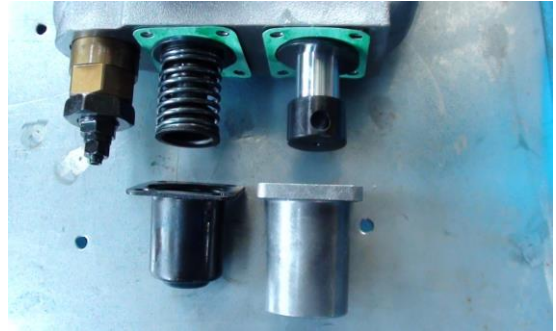

Figure 4

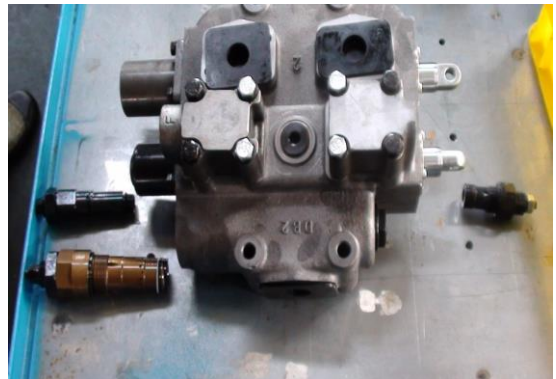

Figure 5

3. Disassemble check valve. Check whether the check valve line is complete and o-ring is in good condition. After cleaning put back the body and screw ; Tightening torque for check valve is 460 -470N.m.

According to the order from 3 to 1 to assemble the GDF-32-00C vavle.



Figure 6

Disassembling of YGDF-32-00C

1. Disassemble the valve stem and end cover.
Take out end cover; Pull stem back and forth, check whether card hysteresis then remove the valve stem. Demolition end cover and pull out the valve stem before cleaning multiple valve and place the valve body on a clean flat place to disassemble. After cleaning end cover, put the stem alignment to the valve hole, slowly assemble the end cover tightening bolts. When moving arm valve lever you should pay attention to the ball. Bolt tightening torque for the two end cover should be 35-40N.m

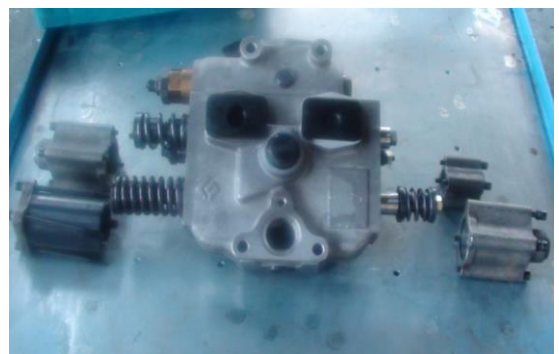

Figure 4

2. Disassemble the relief valve and overload valve.
When remove the relief valve , be careful not to loose overload valve head lock nut, put back to the body after cleaning.



Figure 5

3. Disassemble check valve. Check whether the check valve line is complete and o-ring is in good condition. After cleaning put back the body and screw ; Tightening torque for check valve is 460 -470N.m.



Figure 6

According to the order from 3 to 1 to assemble the YGDF-32-00C vavle.

Basic faults and overcoming

S/N	Faults	Reasons	Overcoming methods
1	Working pressure is not enough	Pressure of relief valve is regulated too low	Adjust pressure of relief valve
		Slide valve of relief valve is blocked	Dismantle, clean and assemble again
		Pressure regulation spring is broken	Replace with new one
		System pipe pressure is lost too much	Replace pipeline or regulate pressure of relief valve within the allowable pressure range
2	Working flow is not enough	Oil supply of the system is not enough	Check oil source, check oil pump
		Leakage in valve is large	
		a. Oil temperature is too high, viscosity decreases	a. Take measures to reduce oil temperature
		b. Selection of oil is improper	b. Replace oil
		c. Clearance between slide valve and valve is too large	c. Replace slide valve according to reasonable clearance
		Fault of relief valve	Repair relief valve
3	Resetting does not work	Resetting spring is damaged or deformed	Replace new ones
		There is pollutant between valve rod and valve	Clean parts
4	External leakage	Sealing ring is damaged	Replace new ones
		Fasteners are loosed	Screw down fasteners
5	Slippage of swing arm is large	Clearance between multi-way valve and valve rod increases	Replace valve rod
6	Rotating bucket falls	Overload valve or oil compensating valve is blocked by pollutant	Dismantle, clean and reassemble

Pilot Control Valve

CAUTION!

Follow all safety recommendations and safe shop practices outlined in the front of this manual or those contained within this section.

Always use tools and equipment that is in good working order.

Use lifting and hoisting equipment capable of safely handling load.

Remember, that ultimately safety is your own personal responsibility.

TABLE OF CONTENTS

General Description.....	3
Schematic Diagram.....	3
Detailed List of Parts for GDXS Mono Lever Pilot Control Valve	4
Disassembly & Assembly Steps of GDXS Mono Lever Pilot Control Valve.....	5
Basic Faults and Overcoming.....	8

General description

Schematic diagram

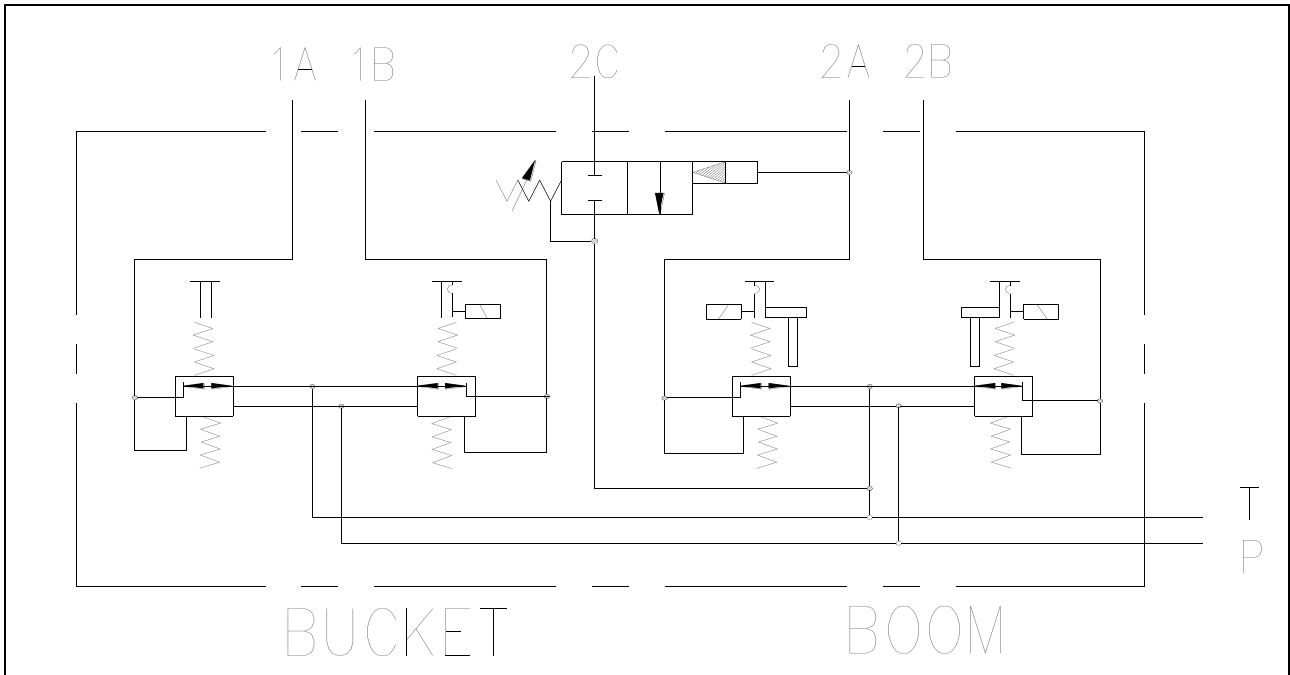

Figure 1

Detailed List of Parts for GDXS Mono Lever Pilot Control Valve

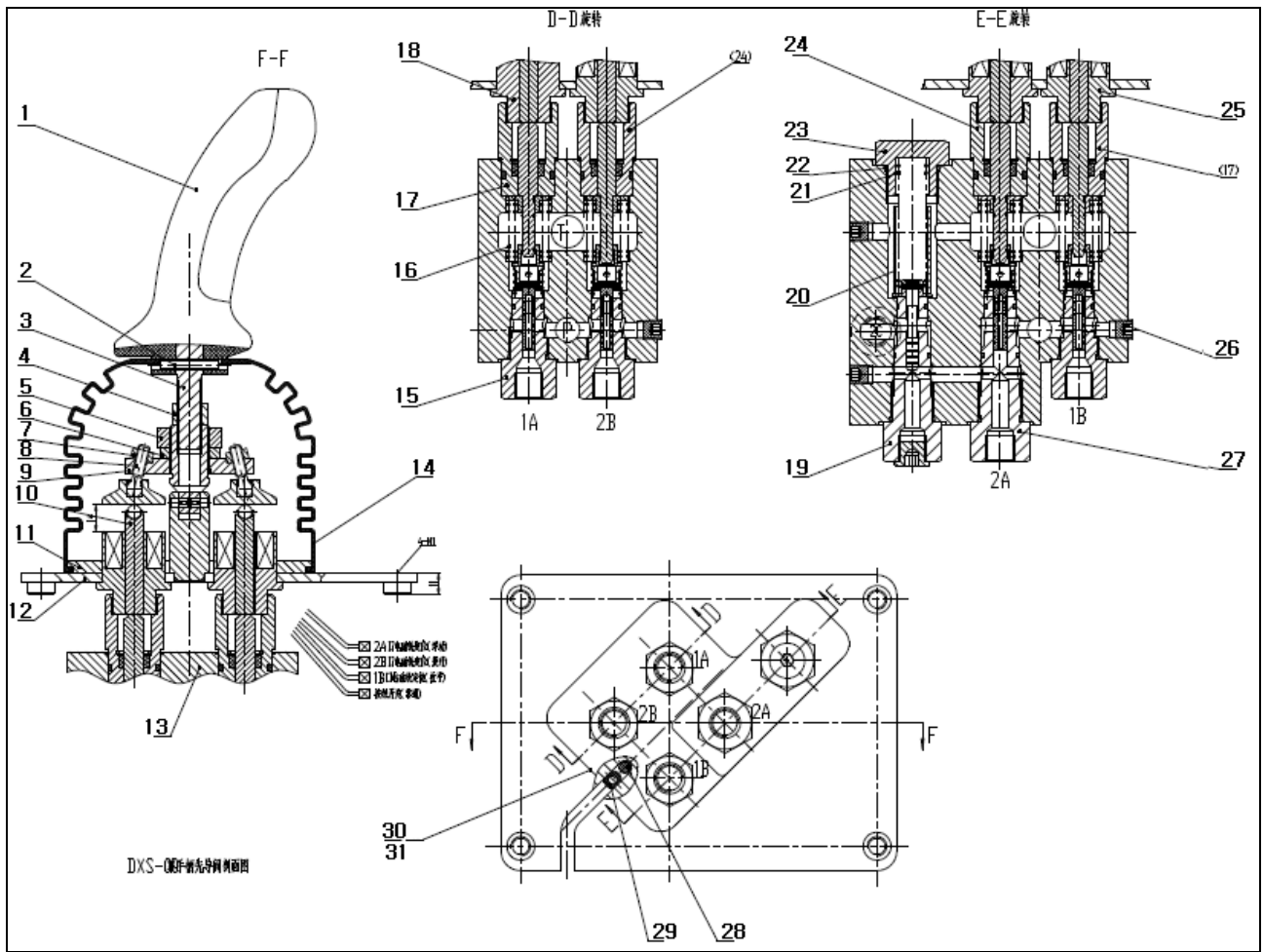

Figure 2

Reference Number	Description	Reference Number	Description
1	Handle assembly	17	Compression bar I
2	Elastic round pin	18	Shaft sleeve
3	Handle joint	19	Sequence valve
4	Nut	20	Guide sleeve
5	Nut	21	Spring
6	Small gasket	22	O ring
7	Nut	23	Screw plug
8	Pressing plate assembly	24	Compression bar II
9	Fixing plate	25	Electromagnet
10	Pressure pin group	26	Cone screw plug
11	Shield plate	27	Measuring assembly II
12	Mounting plate assembly	28	Bolt
13	Valve	29	Rubber plug
14	Rubber cover	30	Name plate
15	Measuring assembly I	31	Rivet
16	Spring		

Disassembly and Assembly Steps of GDXS Mono Lever Pilot Control Valve

Disassembly steps of GDXS mono lever pilot control valve

1. Remove dust cover.



Figure 3

2. Loosen the fastening nut.

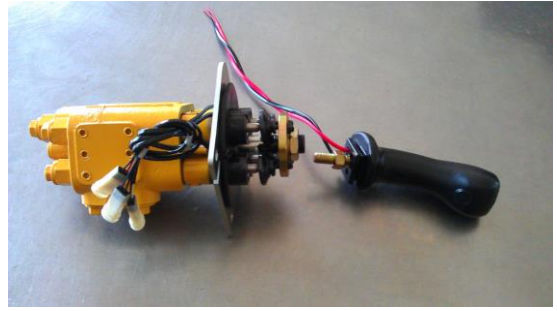

3. Using a wrench turned four pillars of M6X60 fastening screw down, remove the cover plate and installation edition components.

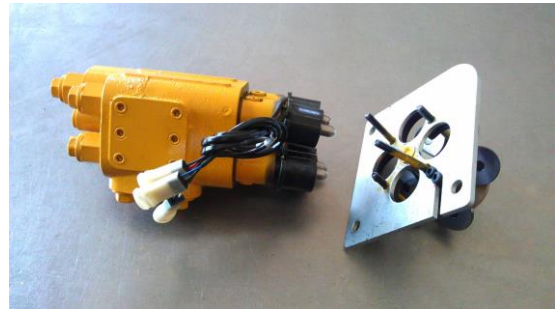

Figure 5

4. Remove magnet assembly .



Figure 6

5. Remove pressure lever components, remove valve core components



Figure 7

Assembly steps of GDXS monolever pilot control valve

1. Assemble valve core components ,pressure rod assembly and magnet assembly in turn. When assemble the pressure rod assembly , set the hole out, loaded down tightly.



Figure 8

2. Cover on the pressure plate assembly and cover plate and screws.



Figure 9

3. Assemble the handle components and lock, set on the dust cover.



Figure 10

Basic faults and overcoming

	Faults	Reasons	Overcoming methods
1	Resetting does not work	Resetting spring of pilot control valve deforms	Replace with new products
		There are pollutants between pressing bar and matching hole	Clean parts
2	Location is not reliable	Suction of electromagnet is not enough	Replace with new ones
		Electric current and voltage of electric circuit does not comply with requirements	Overhaul
		There are pollutants between electromagnet and pressing plate	Get rid of pollutants
		Clearance between pressing bar and pressing lever is not adjusted according to requirements	Adjust according to requirements
3	Control of pilot valve is not flexible	Measuring spool is blocked or moving is not flexible	Check if oil is clean, clean spool and valve port
		Measuring spring deforms	Replace spring
		Control flow rate or pressure is not enough	Check if oil supplying system of pilot is normal

Priority Valve

 CAUTION!

Follow all safety recommendations and safe shop practices outlined in the front of this manual or those contained within this section.

Always use tools and equipment that is in good working order.

Use lifting and hoisting equipment capable of safely handling load.

Remember, that ultimately safety is your own personal responsibility.

TABLE OF CONTENTS

General Description.....	3
Work principle.....	3
Detailed List of Spare Parts.....	4
Disassembly Steps of Priority Valve.....	5
Matters Need Attention for Disassembling Priority Valve.....	6
Assembling Steps of Priority Valve.....	7
Matters Need Attention for Assembling Priority Valve.....	8
Tools for Disassembly and Assembly.....	8

General Description

Work principle

YSF25 steering control valve is control valve parts of steering system, its premise is to guarantee oil supplying to steering system preferentially, when the loader is working under high pressure and small flowrate, the extra oil of steering system can discharge load automatically under lower pressure. Load discharging pressure can be regulated by relief valve according to working conditions, this makes up the shortage of priority valve, reduces power consumption and reduce temperature rising of the system.

The valve is installed at steering oilway, it is between steering pump and load sensing hydraulic steering gear. P mouth is oil inlet which is connected with steering pump. CF mouth is the steering mouth connected with oil inlet of steering gear, EF mouth is the work mouth connected with multiway valve, LS mouth is control mouth connected with load sensing mouth of steering gear, T is load discharging mouth connected with oil tank.

When the load does lifting work, oil from steering pump goes through P mouth and a hole and reaches right side of priority valve spool, it will overcome control pressure of priority valve spring with the effect of pressure oil, pushes priority spool moving to the left, oil from steering pump opens check valve and goes to work system through EF mouth to satisfy big flow rate requirements of the loader. When the loader is under high pressure and small flow rate, high pressure oil of EF mouth will make load discharging relief valve I start, control oil goes to the left side of load discharging spool through b oilway, reaches T mouth through c small hole, the pressure difference makes load discharging spool overcome spring force of relief valve and move to the right, oil from P mouth will go to load discharge mouth T and discharge load directly.

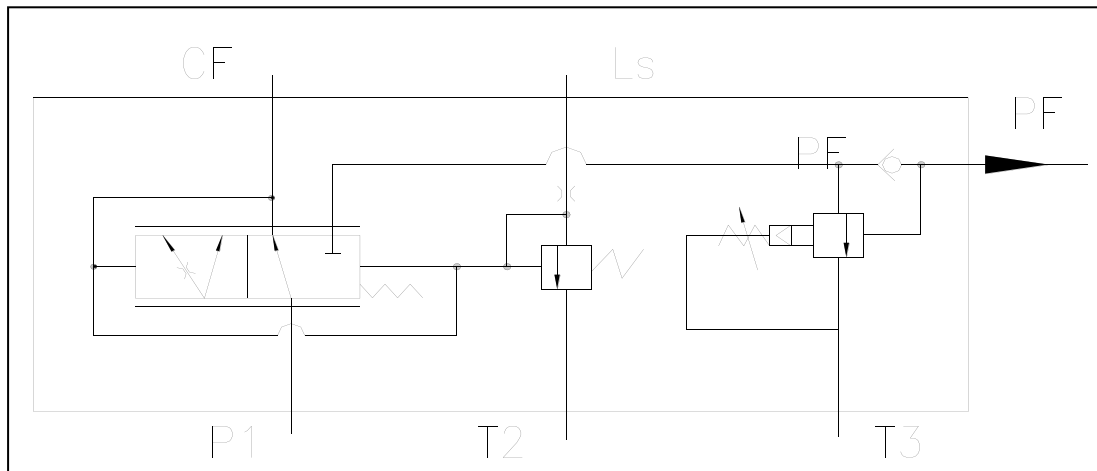

Figure 1

Detailed list of spare parts

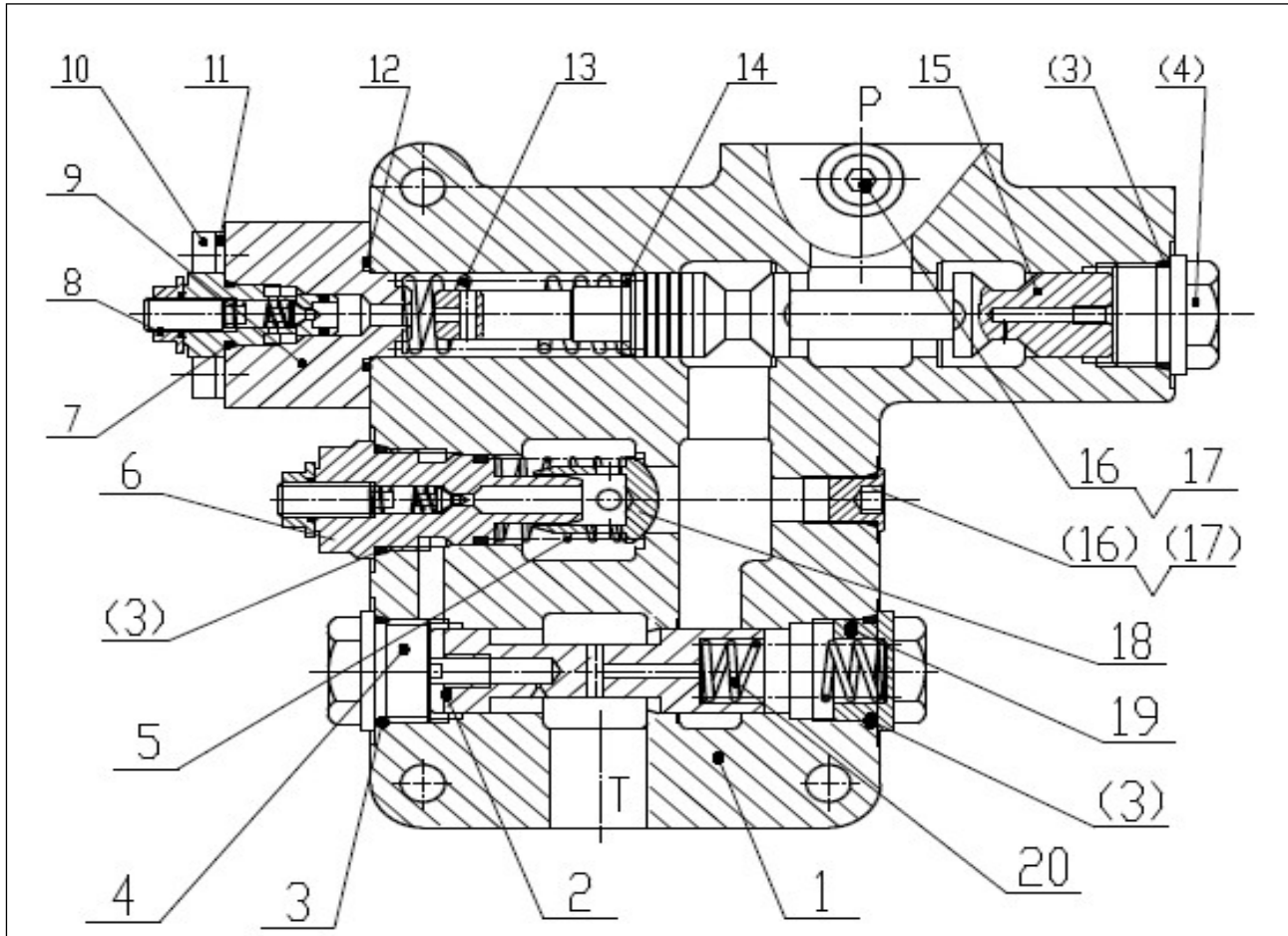

Figure2

Reference Number	Description	Reference Number	Description
1	Valve body	11	Gasket 10
2	Valve spool	12	O-Ring 28X2.65
3	O-Ring 26.5X2.65	13	Priority Valve Spring
4	PlugI	14	Priority Valve Gasket
5	Check Valve Spring	15	Priority Spool
6	Relief ValveI	16	O-Ring 11.8X2.1
7	O-Ring 15X1.8	17	Plug
8	Relief ValveII	18	Check Valve
9	Relief Valve seat	19	PlugII
10	Bolt M10X50	20	Relief Valve Spring

Disassembly steps of priority valve

1. Screw off screw plug I on the left, take out load discharging spool, load discharging spring, screw out plug II from the right side.

Tools: torque (electric) wrench, m27 sleeve

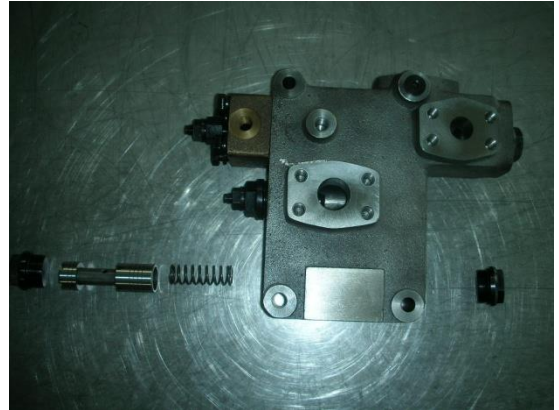

Figure 3

2. Open relief valve I from the left side, take out check valve spring, check valve, and screw out plug from the right side.

Tools: torque (electric) wrench, m27 sleeve, m6 inner hexagonal spearhead

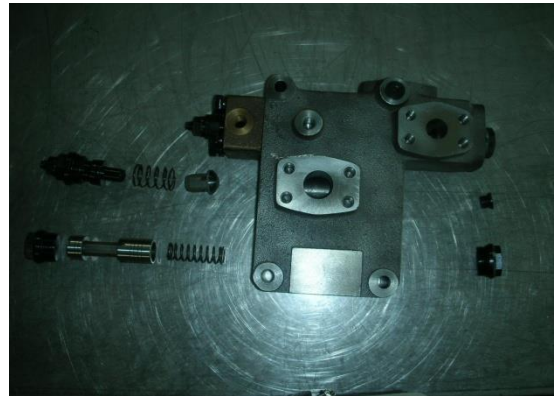

Figure 4

3. Screw off relief valve I and relief valve seat on the left, take out priority spring, priority spool and screw out plug I from the right side.

Tools: torque (electric) wrench, m27 sleeve, m22 sleeve and m16 sleeve



Figure 5

Matters need attention for disassembling priority valve

1. Plug of pressure mouth is only screwed out when testing pressure; it does not belong to disassembling range (same principle for assembling).
2. Pull out valve spool slowly, pay attention to protect valve body hole, plug combination surface and thread from damaging.
3. Check if O ring is deformed, trimmed and aged after disassembling, usually O ring cannot be used again after disassembling.
4. After disassembling, valve body and spool shall be cleaned with 32# hydraulic oil, check if spool surface has obvious scratch; do not use spool and valve body if there is scratch.

Assembling steps of priority valve

1. Install relief valve II, relief valve seat, priority spring, priority spool and plug I into valve body from left to right.

Tools: torque (electric) wrench, m27 sleeve, m22 sleeve and m16 sleeve

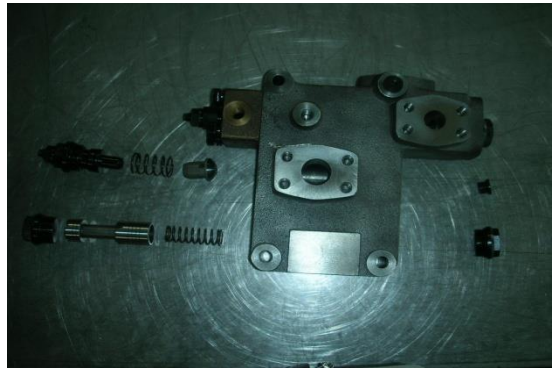

Figure 6

2. Install relief valve I, check valve spring, check valve and plug into valve body from left to right.

Tools: torque (electric) wrench, m27 sleeve, m6 inner hexagonal spearhead

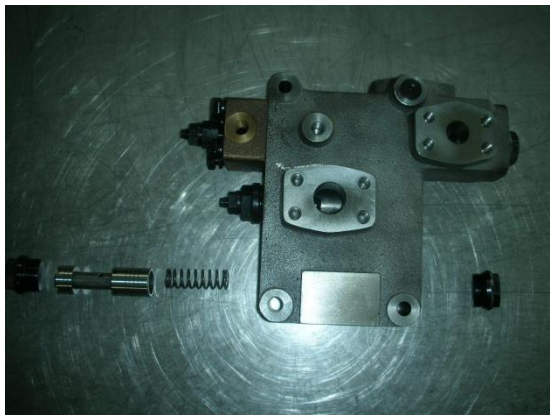

Figure 7

3. Install plug I, load discharging valve spring, load discharging valve spool and plug II into valve body from left to right.

Tools: torque (electric) wrench, m27 sleeve

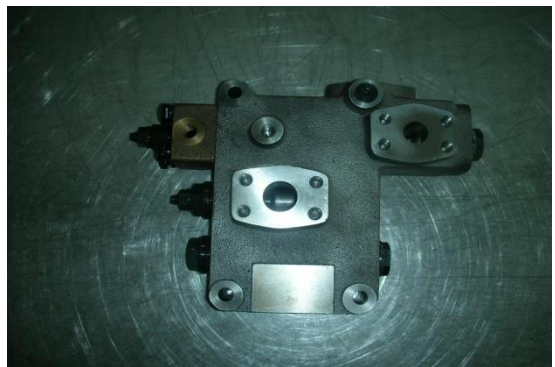

Figure 8

Matters need attention for assembling priority valve

1. Keep all parts clean before assembling.
2. During installation, all spools shall be installed slowly and guarantee they can slide flexibly, if there is blockage, grind spool surface and sharp corner slightly with fine abrasive paper, reclean the valve.
3. Avoid to damage trim of O ring when screwing on screw plug, it is better to coat grease on the surface before installation.

Tools for disassembly and assembly

Main tools for disassembly and assembly are:

Torque wrench (Electric wrench)

M27 sleeve

M22 sleeve

M16 sleeve

M6 inner hexagonal spearhead



Figure 9

Steering Unit

 CAUTION!

Follow all safety recommendations and safe shop practices outlined in the front of this manual or those contained within this section.

Always use tools and equipment that is in good working order.

Use lifting and hoisting equipment capable of safely handling load.

Remember, that ultimately safety is your own personal responsibility.

TABLE OF CONTENTS

General Description.....	3
Work Principle.....	3
Detailed List of Spare Parts.....	4
Disassembly Steps of Steering Unit.....	5
Assembling Steps of Steering Unit.....	11
Matters Need Attention for Disassembling Steering Unit.....	14

General description

Work principle

When steering unit is in the middle, spool and valve bush is at meso-position with the effect of spring lamination, oil from oil pump will enter spool from two rows of holes of valve bush and spool, then returns to oil tank through T oil mouth.

When steering wheel turns right (or left), spool is driven to turn to the right (or left), since the Max. rotation quantity between spool and valve bush is 10.5° , so spool rotates against valve bush, at this moment, oil groove is connected with oil inlet way of valve bush, oil goes through valve bush and oil groove of spool, returns to rotor and stator from valve bush, drives rotor rotating against stator. At the same time, oil from rotor and stator enters one of the chamber of cylinder through oil mouth A (or B) to make cylinder piston stretch out (compress inside), and push steering wheel turns right (or left), oil from the other chamber of cylinder enters valve bush through oil mouth B (or A), returns oil groove through spool, and goes back to oil tank through T oil mouth from valve bush. The relative rotation angle of spool and valve bush is 1.5° , oil way is connected, and rotation of rotor makes oil connects with cylinder, oil supplying quantity and rotation angle of steering wheel become direct ratio.

When steering wheel turns right (or left) for an angle and keeps the state, since the above mentioned oilway is open and oil from oil pump will push rotor to turn right (left), when rotation angle of rotor is the same with rotation angle of steering wheel, since valve bush and rotor is connected through linkage axle, so rotor will drive valve bush to turn right (or left) to keep the same angle with steering wheel. At this moment, valve bush and spool form the position without rotation angle, oilway going to rotor and oil cylinder is closed, oil from oil pump will go into spool through two rows of holes through valve bush and spool, oil goes back to oil tank through T oil way from valve bush. At this time, tyre stops moving, this is hydraulic feedback servo action.

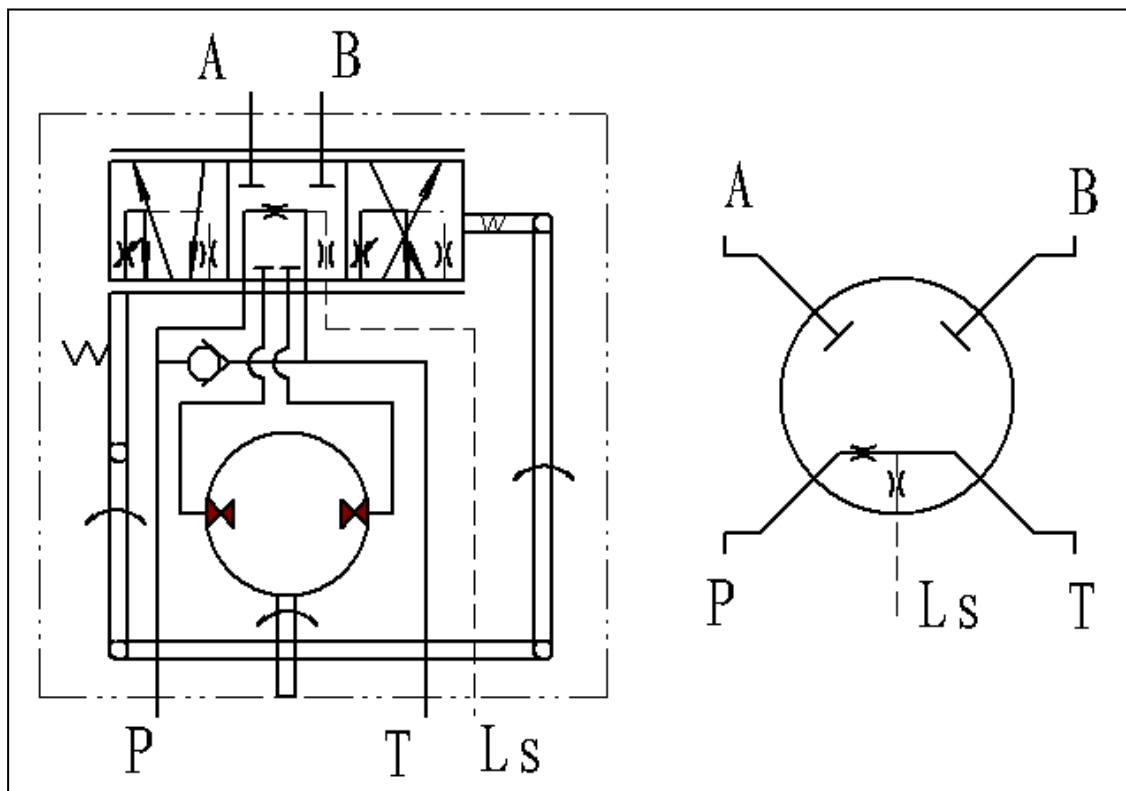

Figure 1

Detailed list of spare parts

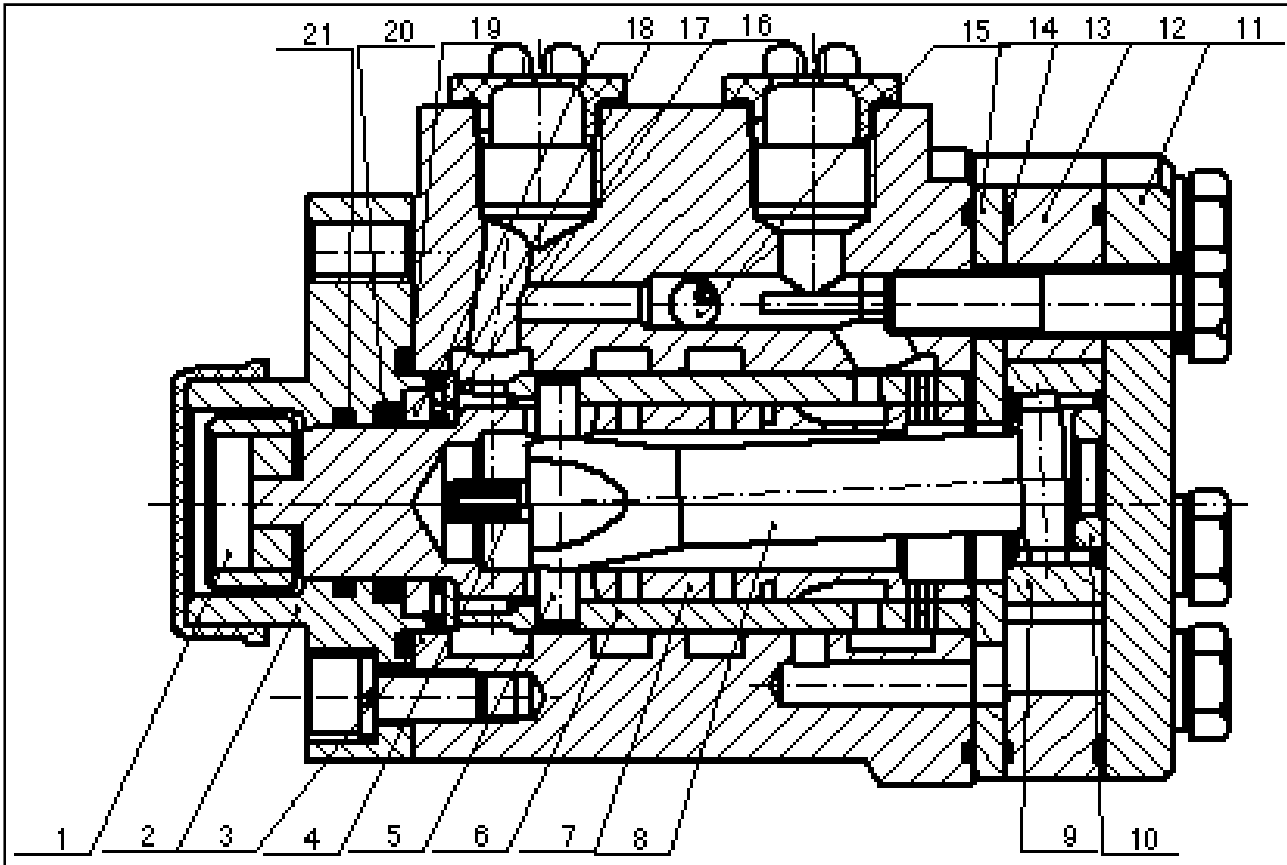

Figure 2

Reference Number	Description	Reference Number	Description
1	Link block	12	Stator
2	Front cover	13	O-Ring
3	Valve body	14	Plate
4	Spring lamination	15	Steel ball
5	Pin	16	Big Baffle ring
6	Valve bush	17	Baffle ring
7	Valve spool	18	Baffle ring
8	Shaft	19	O-Ring
9	Rotor	20	X-Ring
10	Limited post	21	O-Ring
11	Rear cover		

Disassembly steps of steering unit

1. Take out link block.

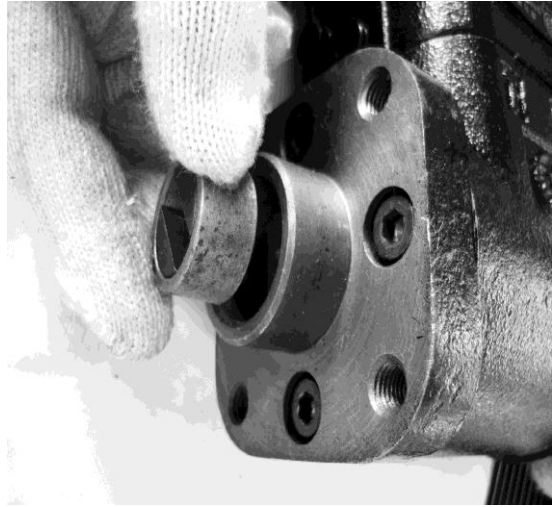

Figure 3

2. Take out front cover.



Figure 4

3. Take out multi-roll bearing



Figure 5

4. Take out bolts of rear cover.



Figure 6

5. Take out rear cover.

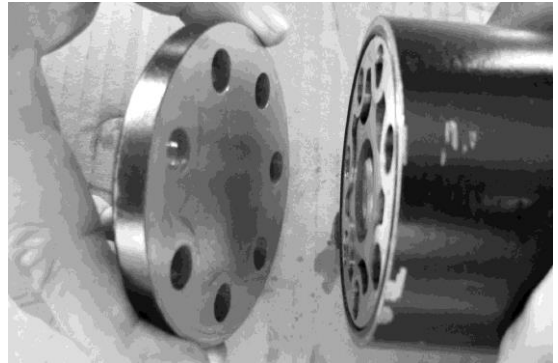

Figure 7

6. Dismantle stator

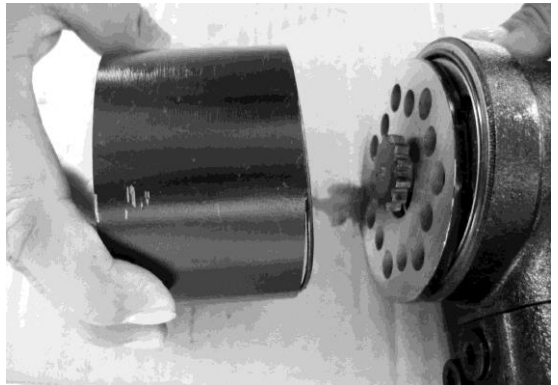

Figure 8

7. O-RING Dismantle O-RING

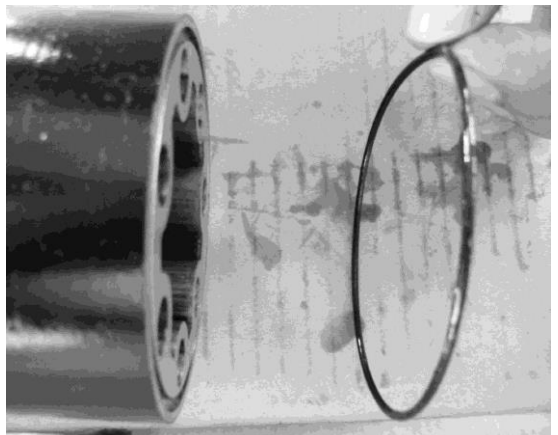

Figure 9

8. Dismantle rotor.

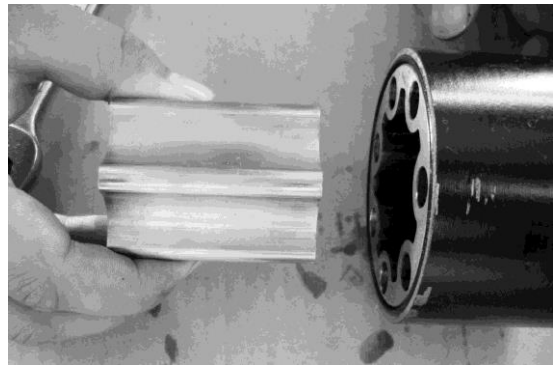

Figure 10

9. Take out limitation block

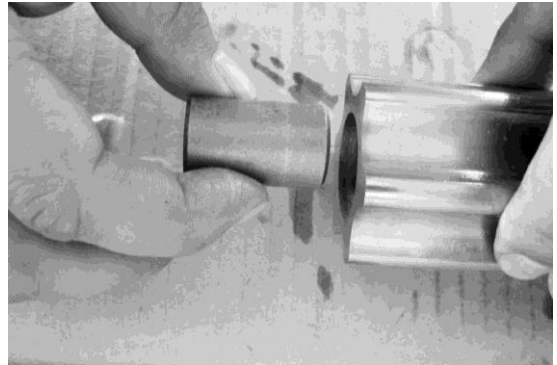

Figure 11

10. Take out link axle

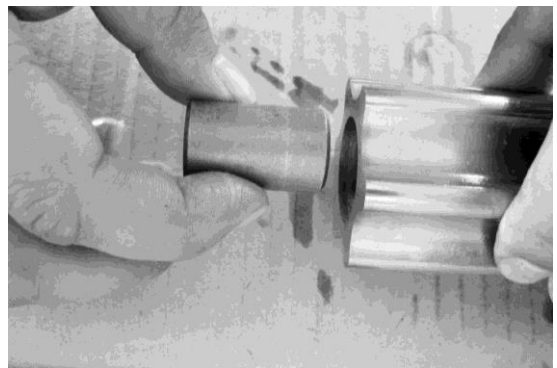

Figure 12

11. Take out clapboard



Figure 13

12. Take out valve bush and spool assembly

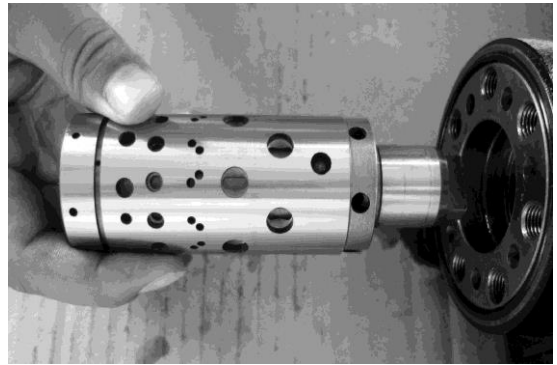

Figure 14

13. Take out dial pin



Figure 15

14. Take out spring lamination



Figure 16

15. Take out valve spool



Figure 17

16. Dismantle valve block

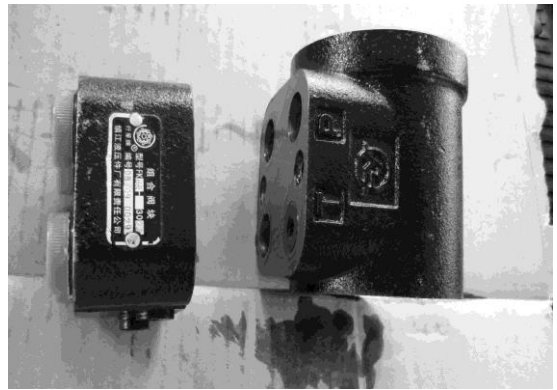

Figure 18

17. Take out check valve



Figure 19

18. Take out oil return throttle valve



Figure 20

19. Take out oil inlet throttle valve



Figure 21

20. Take out oil compensating valve (4EA)

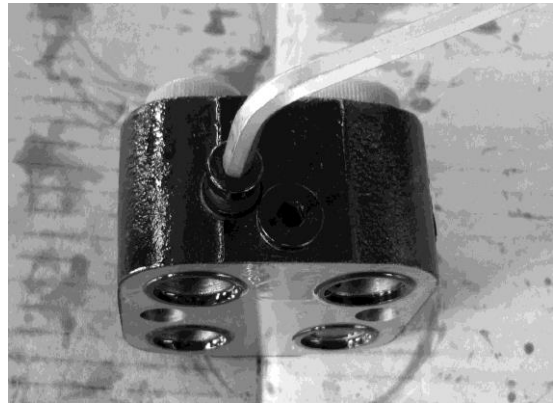

Figure 22

Assembly steps of steering unit

1. Keep four bolt holes of valve body upward.



Figure 23

2. Install valve spool, valve bush, spring lamination and dial pin.



Figure 24

3. Install well assembled valve spool and valve bush into valve body



Figure 25

4. Install big baffle ring, needle roller thrust bearing and small baffle ring



Figure 26

5. Install front cover with well assembled sealing ring



Figure 27

6. Keep fourteen holes of steering unit upward



Figure 28

7. Install sealing ring



Figure 29

8. Put $\Phi 8\text{mm}$ steel balls into the thread holes as shown in the picture



Figure 30

9. Install spacer plate and align the holes.



Figure 31

10. Install couple axle, stop dial pin with linkage shaft



Figure 32

11. Install turn stator vice (note: mark on linkage shaft shall align with groove on rotor)



Figure 33

12. Install upper limitation column and sealing ring



Figure 34

13. Install rear cover, combined gasket, bolts, the position shown in the picture by arrow is cotter bolt.



Figure 35

Matters need attention during assembling

1. Clean all parts (except rubber ring) with gasoline or kerosene before assembling. If there is paint on combination surface, clean with acetone, it is forbidden to clean parts with cotton yarn or cloth, soft banister brush or silk shall be used to clean parts, it is better to blow with compressed air, after steering unit is installed well, add 50-100ml hydraulic oil before install in machines, turn around spool, install in machine for test if everything is normal
2. Combination surface of valve body, spacer plate, stator and rear cover must be highly clean, do not knock or scratch.
3. There are spot mark on end surface of rotor and linkage shaft, that is teeth of linkage shaft groove shall align with multiple spline groove inside rotor teeth bottom, pay attention to the relative position during installation.
4. Bolts of rear cover shall adopt qualified combined gaskets.
5. when fastening seven bolts of rear cover, screw on every two bolts in order, screw on gradually, the fastening torque is 40~50 N.m.
6. (Note) "P", "T", "A", "B" oil mouth of valve body and valve block shall align with each other one by one during installation.

Hydraulic Schematic

CAUTION!

Follow all safety recommendations and safe shop practices outlined in the front of this manual or those contained within this section.

Always use tools and equipment that is in good working order.

Use lifting and hoisting equipment capable of safely handling load.

Remember, that ultimately safety is your own personal responsibility.

TABLE OF CONTENTS

General Description..... 3
Schematic Diagram..... 3

General description

Schematic diagram

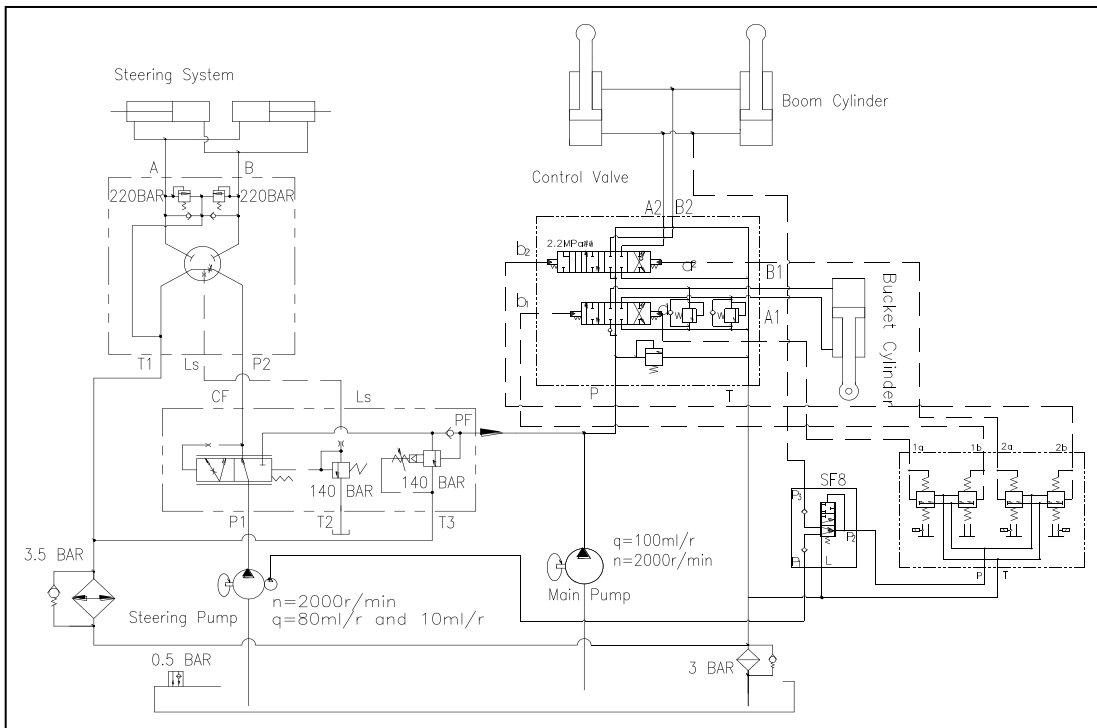
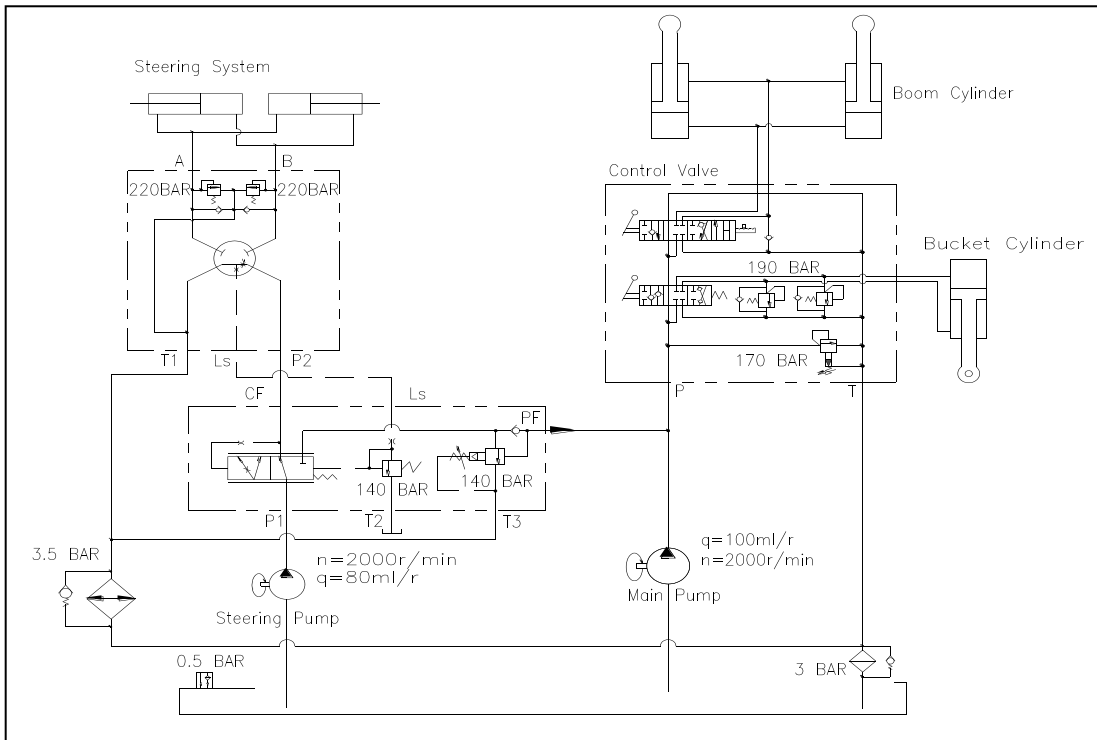

Steering System

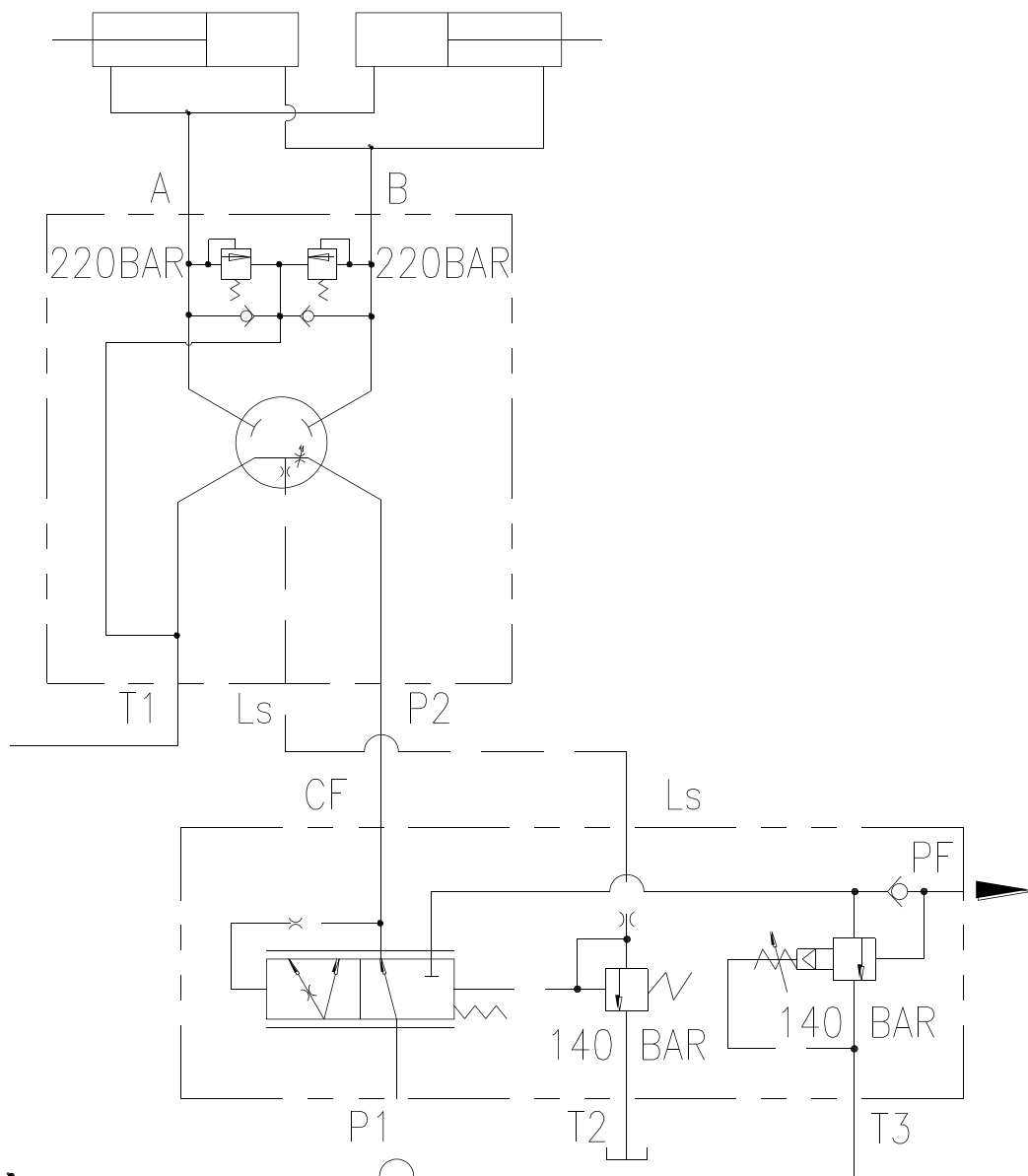

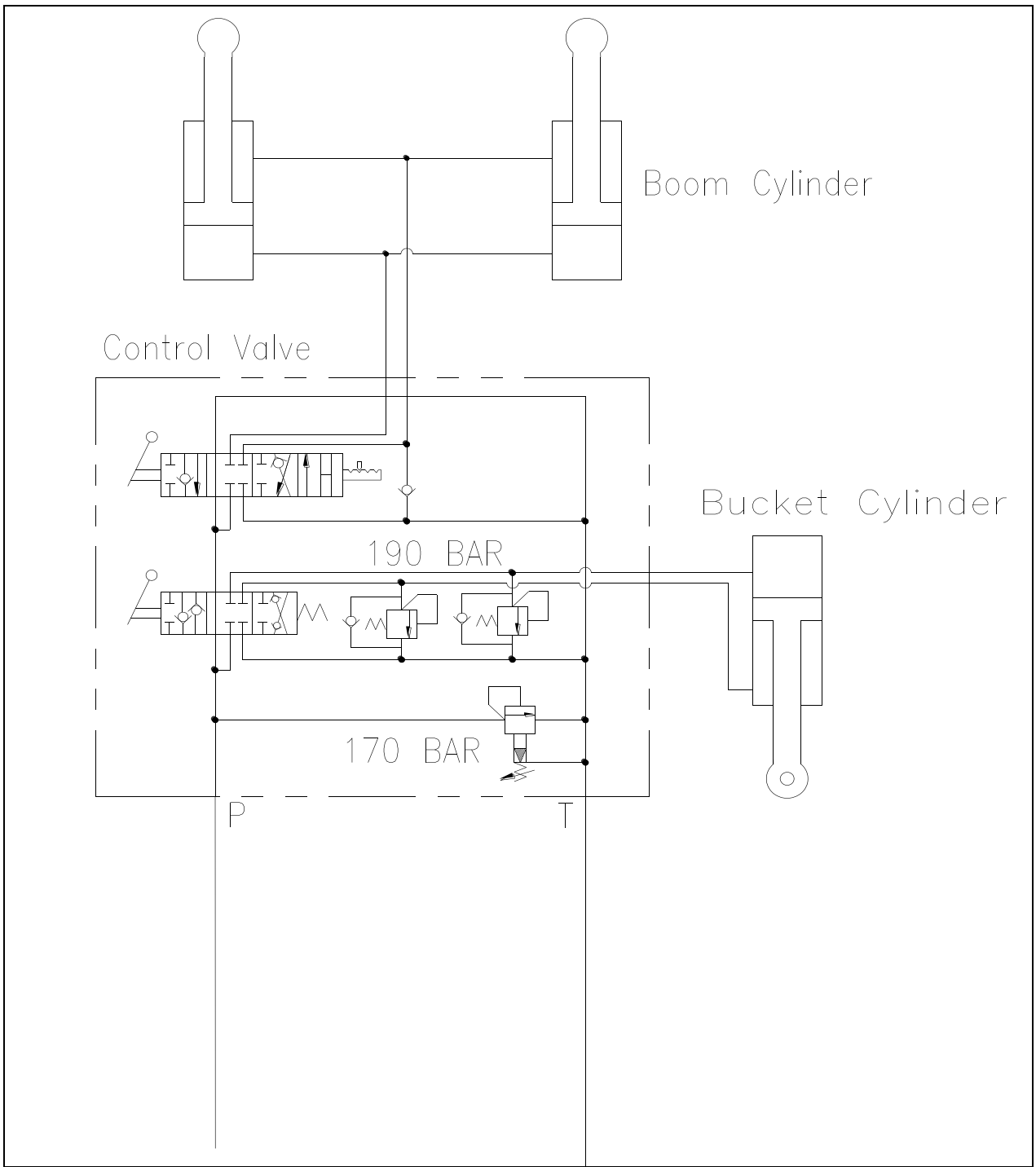

BRAKE

BRAKE SYSTEM

CAUTION!

Follow all safety recommendations and safe shop practices outlined in the front of this manual or those contained within this section.

Always use tools and equipment that is in good working order.

Use lifting and hoisting equipment capable of safely handling load.

Remember, that ultimately safety is your own personal responsibility.

TABLE OF CONTENTS

General Description.....	3
Structure of Travelling Brake	3
Working Principle of Travelling Brake	3
Parts List.....	4
Structure Chart of Brake System.....	4
Oil-water Separator	6
Pneumatic Brake Valve	7
Booster pump	8
Special Tools and Materials.....	8
System Maintenance and Failures Analysis.....	9

General Description

Structure of Travelling Brake:

It usually includes air compressor, oil-water separation combination valve (oil-water separator, pressure control valve), air tank, pneumatic brake valve, air booster pump and caliper disc brake. If it is equipped with emergency braking function, it usually also includes emergency and stopping brake control valve, brake air chamber, quick release valve. In air circuit of brake system, there are some other accessories, such as switch of brake light, switch of power off, etc.

Working Principle of Travelling Brake:

Compressed air is output from air compressor driven by engine, and enters into air tank through oil-water separation combination valve (oil-water separator, pressure control valve). When air pressure in air tank reaches the highest braking pressure (usually around 0.784MPa) of brake system, pressure control valve will close the exit going to air tank, open load discharging mouth and discharge the compressed air from air compressor to the air directly. When compressed air in air tank reaches the lowest pressure (usually around 0.71MPa) of brake system, pressure control valve will open the exit going to air tank, and close load discharging mouth to let compressed air from air compressor into air tank for supplementation until the compressed air in air tank reaches the highest working pressure of brake system.

Following is the fundamental diagram:

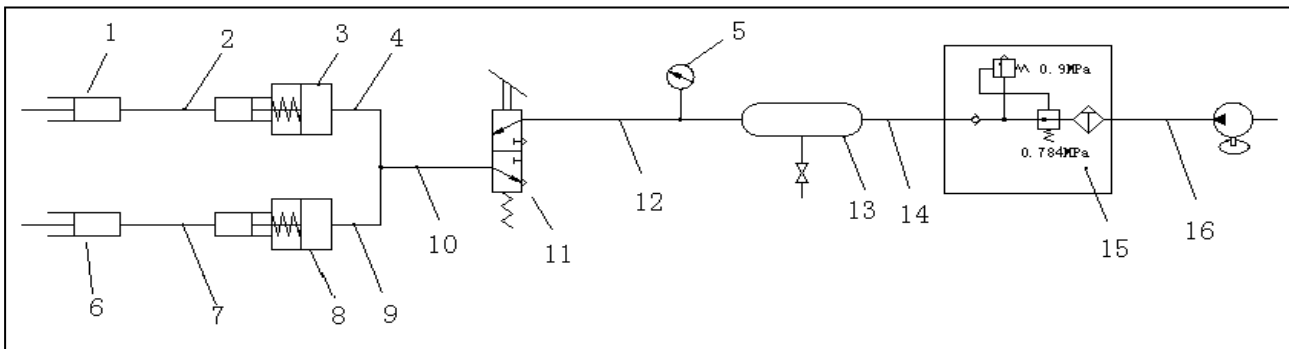

Figure 1

Reference Number	Description	Reference Number	Description
1	REAR AXLE	9	HOSE
2	HOSE	10	HOSE
3	PUMP	11	PEDAL
4	HOSE	12	HOSE
5	SWITCH;PRESSURE	13	ACCUMULATOR
6	FRONT AXLE	14	HOSE
7	HOSE	15	VALVE
8	PUMP	16	HOSE

PARTS LIST

1. Structure Chart of Brake System

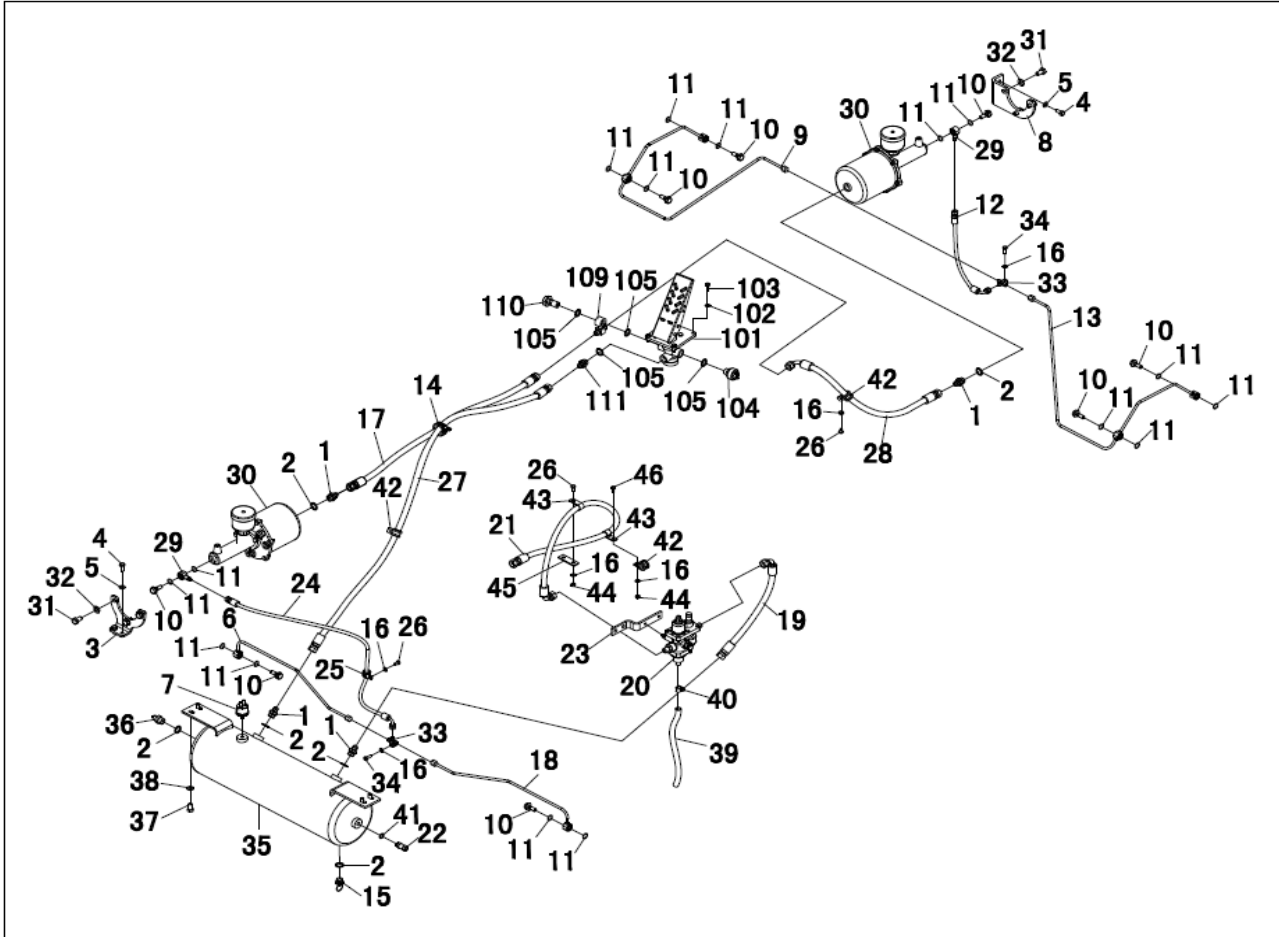

Figure 2

Reference Number	Description	Reference Number	Description
1	ADAPTER	28	HOSE
2	SEAL;RING	29	ADAPTER
3	BRACKET	30	PUMP
4	BOLT	31	BOLT
5	WASHER;PLAIN(M10)	32	WASHER;PLAIN(M14)
6	PIPE	33	TEE
7	SWITCH;PRESSURE	34	BOLT
8	BRACKET	35	ACCUMULATOR
9	PIPE	36	VALVE
10	BOLT	37	BOLT
11	O-RING	38	WASHER;PLAIN
12	HOSE	39	HOSE
13	PIPE	40	CLAMP
14	CLIP	42	CLAMP
15	VALVE	43	CLAMP
16	WASHER;PLAIN(M8)	44	NUT
17	HOSE	45	PLATE
18	PIPE	46	BOLT
19	HOSE	-	BRAKE ASSY
20	VALE	101	VALVE,BRAKE PEDAL
21	HOSE	102	WASHER;PLAIN
22	VAVE	103	BOLT
23	BRACKET	104	SWITCH;LAMP
24	HOSE	105	SEAL RING
25	CLIP	109	ADAPTER
26	BOLT	110	BOLT
27	HOSE	111	ADAPTER

2. Oil-water separator

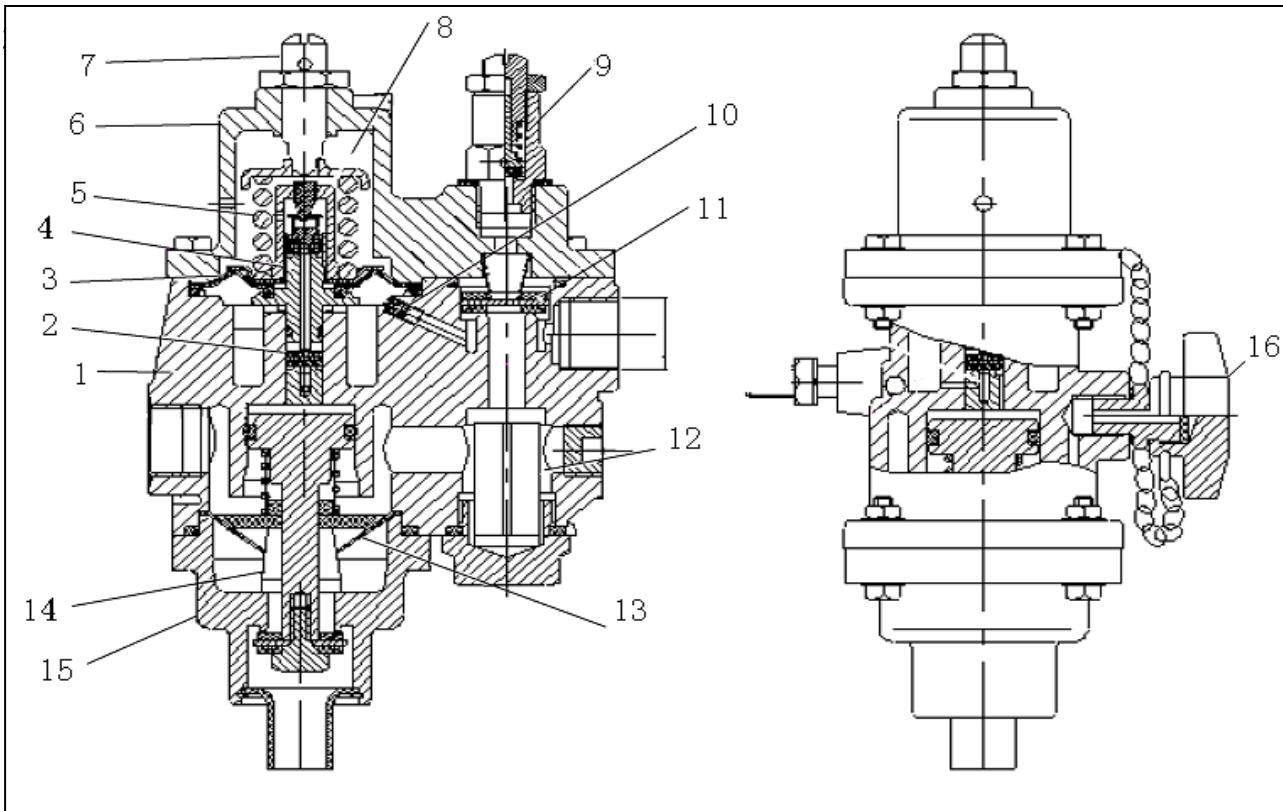

Figure 3

Reference Number	Description	Reference Number	Description
1	SHELL ASS'Y	9	RELIEF VALVE ASS'Y
2	REGULATING VALVE	10	ORIFICE PLUG
3	EAR DRUM	11	ONE-WAY VALVE
4	STEM	12	FILTER ASS'Y
5	REGULATING SPRING	13	OIL COLLECTOR
6	UPPER COVER	14	AIR BLEEDING PISTON
7	REGULATING SCREW	15	LOWER SHELL
8	CONTROLLING PISTON ASS'Y	16	AEROFIOL NUT

3. Pneumatic brake valve

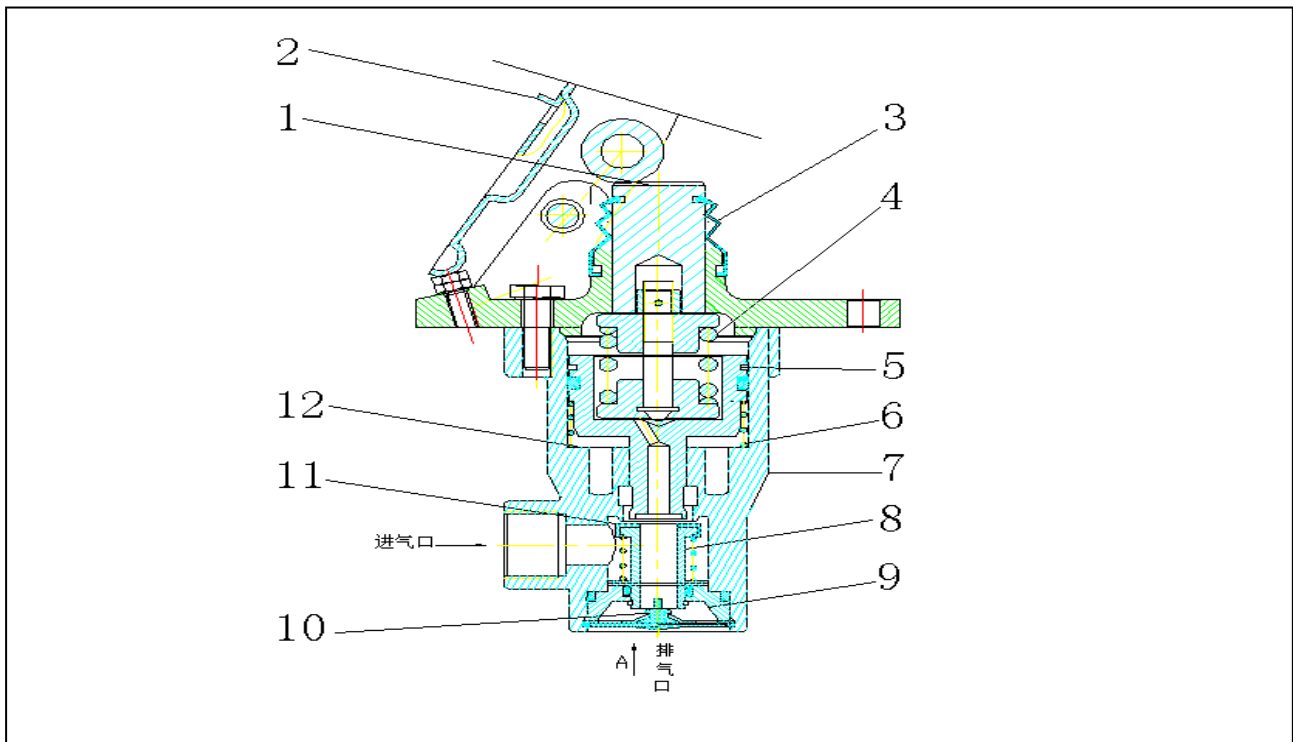

Figure 4

Reference Number	Description	Reference Number	Description
1	MANDRIL	7	VALVE BODY
2	PEDAL ASS'Y	8	INTAKE VALVE ASS'Y
3	ANTIDUST COVER	9	VALVE ASS'Y
4	BALANCING SPRING	10	OUTLET VALVE ASS'Y
5	PISTON ASS'Y	11	SEALING FIN
6	PISTON FOUR SPRING	12	SPRING SEAT

4. Booster pump

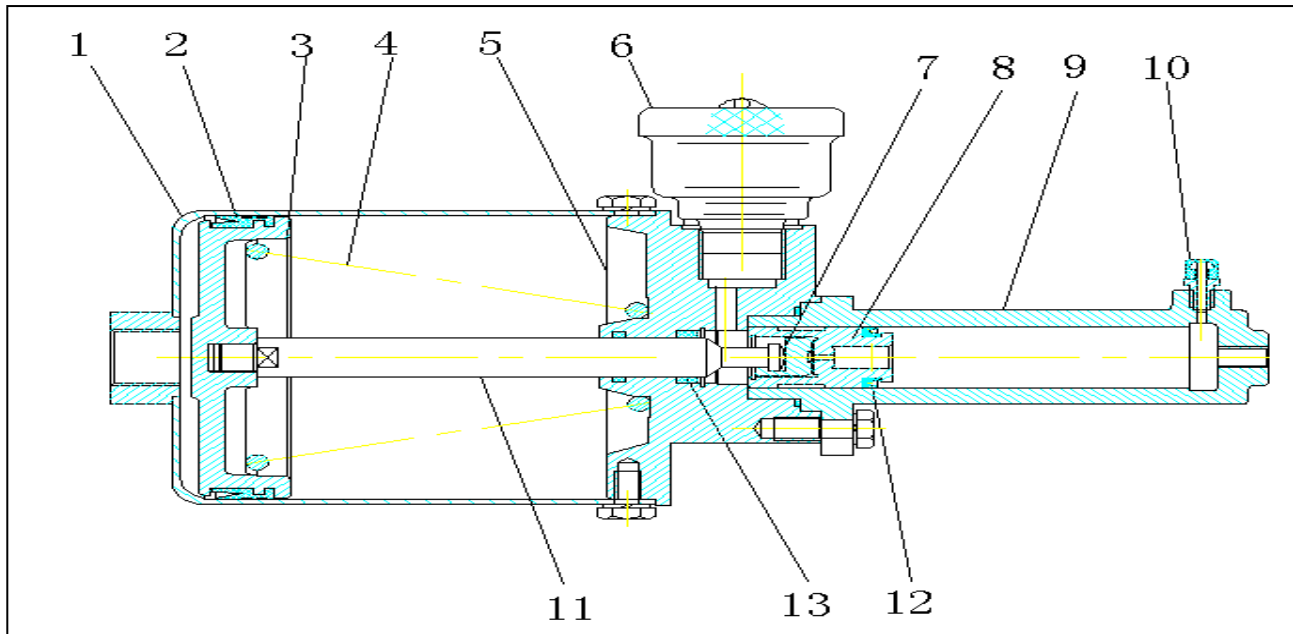

Figure 5

Reference Number	Description	Reference Number	Description
1	STRENGTH CYLINDER	8	PISTON
2	Y-SEAL RING	9	BREAKING PUMP
3	PISTON	10	AIR OUTLET SCREW
4	RELEASING SPRING	11	PUSHING BORER
5	ENDPLATE	12	MAIN PUMP FUR BOWL
6	STORAGE CUP	13	X-SEAL RING
7	PUTTING SEAT		

SPECIAL TOOLS AND MATERIALS

LUBRICANTS, SEALANTS AND OIL

System Maintenance and Failures Analysis

Brake caliper is locking

The so called "locking" failure refers to brake caliper does not return to the original position, that is one of the common failures of brake system. There are many reasons causing such kind failures, such as brake caliper is blocked, booster pump is blocked or brake caliper valve is blocked. If the brake caliper of front and rear bridge is locking, it is may caused by blocking of pneumatic brake caliper. When the failures are solved, loosen pipeline between booster pump and brake caliper, manually check if the brake caliper can return, if it does not work, it may be caused by blocking of brake caliper, if it can be returned manually, but booster pump may be blocked.

No brake or brake distance is too long

1. Pressure adjustment is improper, which causes pressure of compressed air is too low, brake moment is too small. Adjust pressure gauge to the regulated range.
2. It may be caused because air compressor is air leaking or air inlet and outlet valve are blocked because wearing of cylinder barrel and piston ring is too much, driving belt is too loosened. The worn parts shall be replaced in time.
3. Foot brake valve is adjusted improperly, when brake pedal is stepped to the end, air inlet valve of brake valve is not totally opened, air throttle is caused, air pressure becomes weak when going through foot brake valve, and it cannot reach rated working pressure. Adjust the adjusting screw of brake pedal.
4. Failure of booster pump: sealing ring of booster pump is worn, compressed air goes into low pressure chamber, and movement of brake pump piston is slow, or even there is no moving distance, which cause braking power is not enough; compensation hole of brake pump is blocked by dirt, brake fluid cannot go into ante chamber of piston and oil in brake oilway is not enough.

Brake lags behind

1. Air in brake system is not evacuated, air is compressed when braking, air resets when releasing brake, which affects returning of friction plate.
2. Brake air pressure is not enough;
3. Piston of brake caliper is blocked;
4. Foot brake air bleeder or filter screen is blocked, return spring of valve core is broken, piston cannot return and blocks outlet of air hole, which makes brake air discharging is not smooth, brake pressure and oil pressure cannot reduce quickly, brake moment cannot be released, thus it is laged behind.
5. The hole of non-pressure chamber of booster pump connecting with air is blocked or return spring is broken, which affects sensitivity of chamber piston return and cause lag.

Braking deviation

The direct reason of braking deviation is the brake moments of the left side and right side wheels are different, the common phenomenon are:

1. Brake caliper of one side of the wheel is locking, it is hard to trip off during travelling, and usually the rectangle sealing ring of brake caliper is broken.
2. When stepping foot pedal, one side brake caliper is braking, while the other side is inside leaking and oilway is blocked, brake fluid cannot go into brake caliper, which makes different brake moments and causes deviation. Under such kind of condition, please check if the sealing rings of gas cap and brake caliper are turned up or the pipelines are blocked.

There is scream during braking, and brake is hot

1. Connection screws between brake caliper and drive axle are loosed, they rub, impact or abrade each other.
2. There are hard things between brake lining and brake disc.

Storage and usage of brake fluid

1. Brake fluid belongs to inflammable goods; please pay Note to avoid evaporation and fire during usage and storage.
2. Brake fluid shall be stored in warehouse or other assigned place, but it cannot be stored in open air and close to hot source to avoid deteriorating and become invalid.
3. The using department shall set up independent room for storage and there must be obvoid marks.
4. It is forbidden to mix and use brake fluid of different brands to avoid layering and lose braking effect.
5. There must be special containers to store brake fluid to avoid mixing of other oil and cause reaction and invalidity.
6. Containers storing brake fluid must be clean and covered to avoid mechanical sundries and water. If the surface of brake fluid has dust and sundries, they must be removed before using, do not mix them, clean and special tool shall be used to add brake fluid.

Replacement of brake fluid and Notes:

Technicians shall guide clients to use and replace brake fluid strictly, when following conditions appear, all brake fluid must be replaced immediately.

1. When brake fluid is mixed with mineral substance, such as gas oil and diesel.
2. When vehicle is travelling normally, brake is light and heavy.
3. When brake fluid in the system is less or when the vehicle having liquid level is warning.
4. When oil color of brake fluid is muddy or there are sundries and sediment.

Notes during replacement:

1. When replacing brake fluid, clean the residual liquid in brake system, and check new brake liquid.
2. When replacing brake fluid, try to reduce the contacting time between brake fluid and air to avoid reducing performance of brake fluid.
3. Before replacing brake fluid, it is better to clean brake system with alcohol, release air in the oilway after replacement.

Treatment of air source

1. Clean air filter core in time.
2. Release water from air tank in time.

PARKING SYSTEM

CAUTION!

Follow all safety recommendations and safe shop practices outlined in the front of this manual or those contained within this section.

Always use tools and equipment that is in good working order.

Use lifting and hoisting equipment capable of safely handling load.

Remember, that ultimately safety is your own personal responsibility.

TABLE OF CONTENTS

General Description.....	3
Structure of Parking Brake.....	3
Working Principle of Parking Brake	3
Parts List	4
Assembly Structure Chart	4

General Description

Structure of parking brake

Brake is located at the front end of output axle of gearbox.

Driven method is pneumatic control. Pneumatic control usually has emergency brake function. When brake pressure is lower than safe pressure, the system can stop loader automatically.

Working principle of parking brake:

When the loader is driven normally, emergency and parking brake control valve are normally open. Compressed air from air tank goes through emergency and parking brake control valve, quick release valve, one part goes into brake chamber to push piston, compressed spring in brake chamber and store energy. The other part goes into the small chamber of stop valve of variable speed control valve, and connects with shift gear oilway. When emergency and parking brake are needed, emergency and parking brake valve is controlled to stop compressed air, brake chamber, compressed air in stop valve chamber will be discharged into air through quick release valve, shift gear oilway is stopped, gear box is on empty gear automatically, at the same time spring in brake chamber is released to push piston driven shoe brake in brake chamber to realize parking brake or emergency brake. When pressure of brake system is lower than safe pressure (0.3MPa usually), emergency and parking brake control valve will act automatically to realize emergency brake.

PARTS LIST

Assembly structure chart

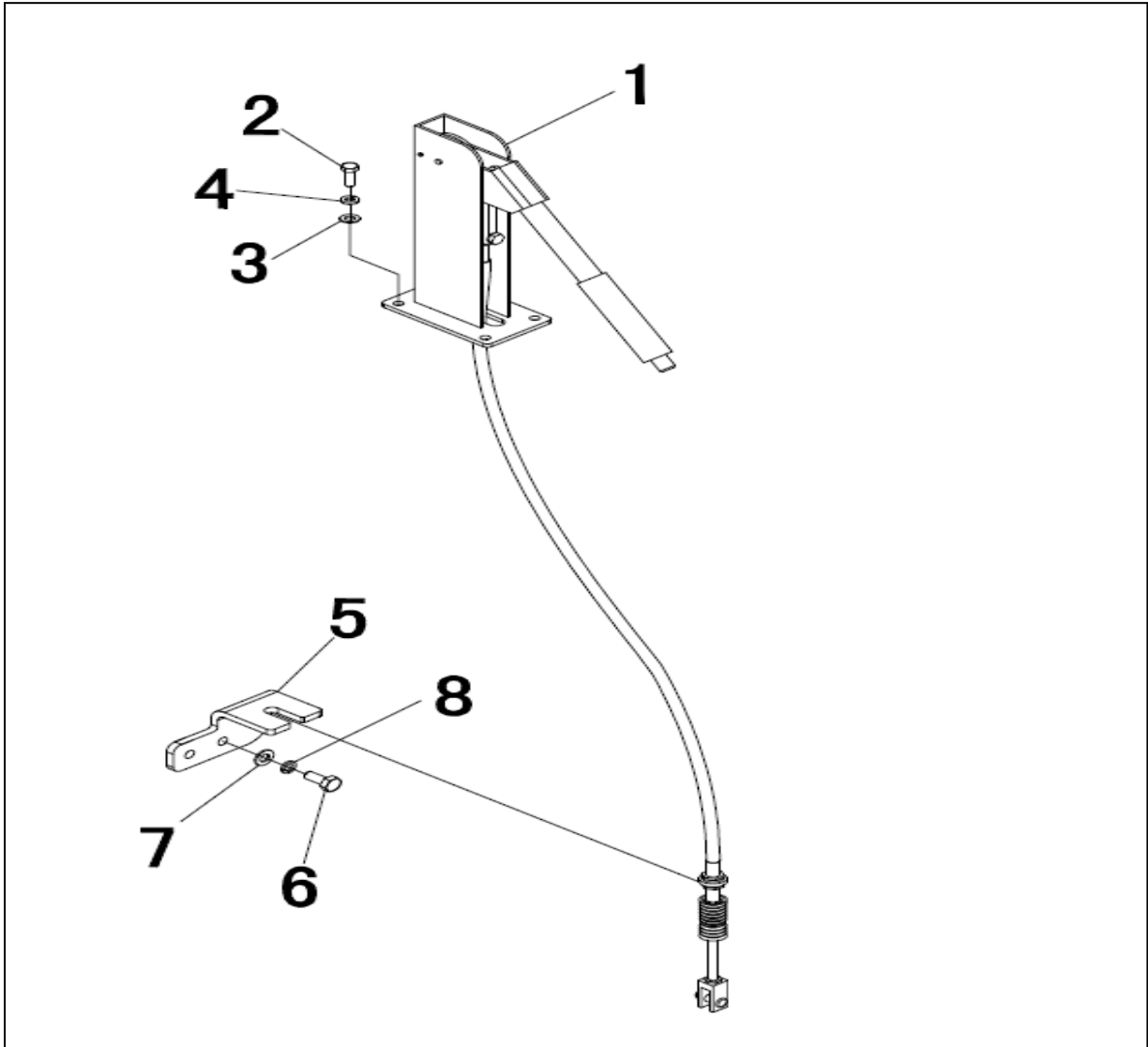

Figure 1

Reference Number	Description	Reference Number	Description
1	BRAKE;PARKING	5	BRACKET
2	BOLT	6	BOLT
3	WASHER	7	WASHER
4	SPRING WASHER	8	SPRING WASHER

ELECTRICAL SYSTEM

ELECTRICAL SYSTEM

CAUTION!

Follow all safety recommendations and safe shop practices outlined in the front of this manual or those contained within this section.

Always use tools and equipment that is in good working order.

Use lifting and hoisting equipment capable of safely handling load.

Remember, that ultimately safety is your own personal responsibility.

TABLE OF CONTENTS

Overview.....	3
Electric Wire Color.....	3
Electric Supply System.....	5
Engine Starting Circuit.....	7
Operation during Start Process.....	7
Operation after Start Process	7
Engine Preheating System.....	9
Principle of Operation	9
Engine Stop System.....	11
Operation in Engine Running Mode.....	11
Operation in Engine Stop Mode	11
Charging System.....	13
Monitoring System.....	15
Gauge Panel.....	16
Windshield Wiper.....	21
Lighting System.....	22
Electric Detent System.....	24
Electric Circuit	24
Boom Kick-Out.....	25
Return to Dig.....	25
Proximity Switch.....	25

OVERVIEW

Voltage of electrical system of the machine is DC 24V, the rated voltage of all electrical parts is 24V. Electrical cable wire adopts single wire system, and negative earth is adopted. Electrical system includes two serial 12V storage batteries and three phase DC generator with entire rectifier. Wire harness of the system can be distinguished by different insulation color. Each color symbol used for electrical system is listed below.

Electric Wire Color

Symbol	Color
W	White
G	Green
Or	Orange
B	Black
L	Blue
Lg	Light Green

Symbol	Color
R	Red
Gr	Gray
P	Pink
Y	Yellow
Br	Brown
V	Violet

NOTE: *RW: Red wire with White stripe.
R - Base Color, W - Stripe Color.*

NOTE: *0.85G: Nominal sectional area of wire core less insulator = 0.85 mm² (0.03 in²).*

ELECTRIC SUPPLY SYSTEM

Power circuit supplies electric current to each electrical part. It is composed of storage battery, generator, fusible line and fuse box. Negative electrode of storage battery is earth connected and connects with balance weight.

Even if keys switch is at "OFF" position, when the general power is switched off, storage battery still supplies electric current to following parts, and returns back to fuse box through fusible link.

1. Input terminal of storage battery relay power supply.
2. Key switch terminal "B".
3. Cabin light power supply terminal.
4. General stop electromagnet power input terminal.
5. Generator terminal "B".
6. Preheat relay power input terminal.

When switch of keys is at "ON" and "START" position, electric current flows to fusible wire from storage battery, reaches key switch terminal "B"/"BR" through fuse box, and reaches storage battery relay control terminal "+" through guide line, activate storage battery relay coil and make the system power on.

When all contact terminals of storage battery are connected well, electrical device can be operated.

When generator does not work, all electrical equipments power source is supplied by storage battery. Once diesel engine is started, power will be supplied by generator.

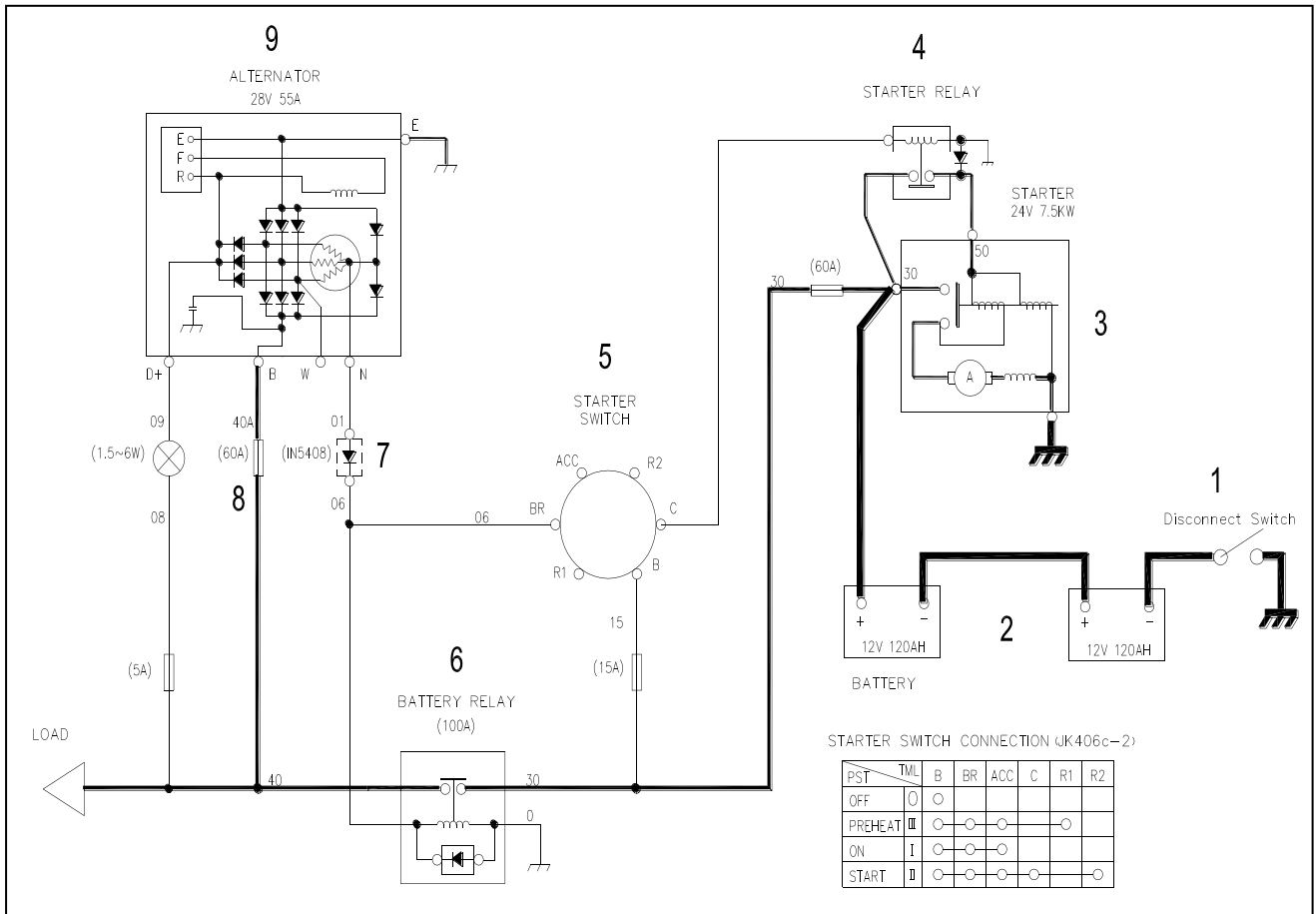

Figure 1 Power supply circuit diagram

Reference Number	Description	Reference Number	Description
1	Disconnect Switch	6	Battery Relay
2	Battery	7	Diode
3	Starter	8	Fuse
4	Starter Relay	9	Alternator
5	Starter Switch		

ENGINE STARTING CIRCUIT

Operation during start process

Turn key switch (6) to "ON" position, connect terminal "B" and "BR", output electric current starts power relay (8), then fuse box is power on.

After key switch (6) is turned to "ON" position, terminal "R2" and "B" are connected, starter relay (4) is started, then other contact terminals "B" and "PP" are connected, active gear of starter (3) is propelled to contact ring gear of flywheel and connect with contact terminal of starter.

Electric current comes out from storage battery (2), goes through terminal "B" and "PP" of starter relay (4) and arrives at starter (3) terminal "50".

Operation after start process

Once generator is started, the belt will drive AC generator (9) to create electric current. Electric current goes through generator (9) terminal "B", safety plate (7), power relay (8) terminal "B" and supply power to fuse box.

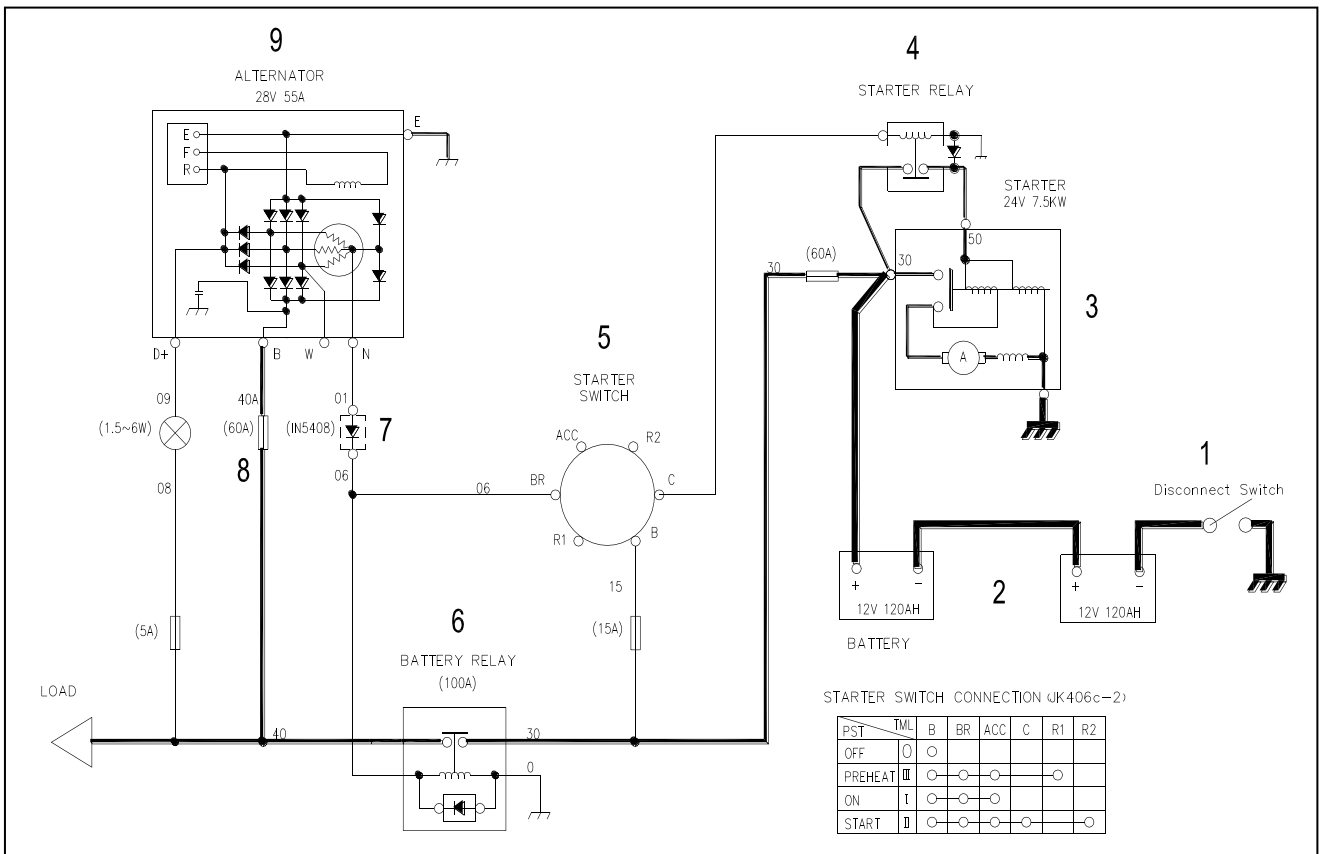

Figure 2 Starter circuit

Reference Number	Description	Reference Number	Description
1	Disconnect Switch	6	Starter Switch
2	Battery	7	Fuse
3	Starter	8	Battery Relay
4	Starter Relay	9	Alternator
5	Diode		

Engine Preheating System

Engine preheating system is flame preheating system, its main functions are: heat air inlet temperature through burning diesel to solve the problem that engine is difficult to be started in winter resulted from low temperature. Main parts include: preheating switch (6), temperature sensor (11), preheating controller (7), preheating indicator (12), preheating relay (8), flame preheating solenoid valve (10) and preheating plug (9).

Working principle:

1. Preheating switch (6) is turned on;
2. When water temperature of engine is higher than 0°C (water temperature R_t resistivity is smaller than $2700\pm 300\Omega$), controller (7) is not at preheating state, preheating indicator light (12) is on for 2S and then off;
3. When water temperature of engine is lower than 0°C (water temperature R_t resistivity is smaller than $2700\pm 300\Omega$), controller (7) is at preheating state; preheating time is related with voltage;

Relationship between preheating time and voltage

Voltage (V)	18	20	22	24
Time (S)	55 ± 5	41 ± 4	30 ± 3	26 ± 2

4. When preheating time is up, preheating indicator light (12) is off (if ignition switch is off during preheating time, controller stops working), it enters into 30S period waiting for starting;
5. ① Turn off starting gear (ON) of ignition switch (4) during this period (preheating plug is power on during this period), oil supplying solenoid valve is connected, preheating indicator light (12) is on again, flame preheating plug (9) is power on;
6. ② Turn off starting gear (ON) of ignition switch (4) during this period, 24V voltage is not input into 50 terminals, engine is not starter, controller stops working;
7. After starting switch (4) is reset from starting position, if generator (3) does not send out "D+" signal to controller (7) (that is starting is unsuccessful), controller stops working after 6S; if generator sends out "D+" signal to controller (that is starting is successful), after entering into preheating period, working time R_t resistivity and water temperature sensor (11) is functional relation, the longest is 120S, the shortest is 60S;
8. When R_t circuit of water temperature sensor (11) is broken, the system enters into preheating state, after all starting procedures are finished, preheating indicator light (12) blinks for 15S for warning, the heating time is the longest of the system after then;
9. When working voltage is lower than 15V, the system does not at preheating state, preheating indicator light (12) blinks for 15S for warning.
10. When controller (7) stops working under any working state, preheating switch (6) must be turned off to enter into preheating state again, that is cancelling 15 terminals voltage, connects with preheating switch (6) again.

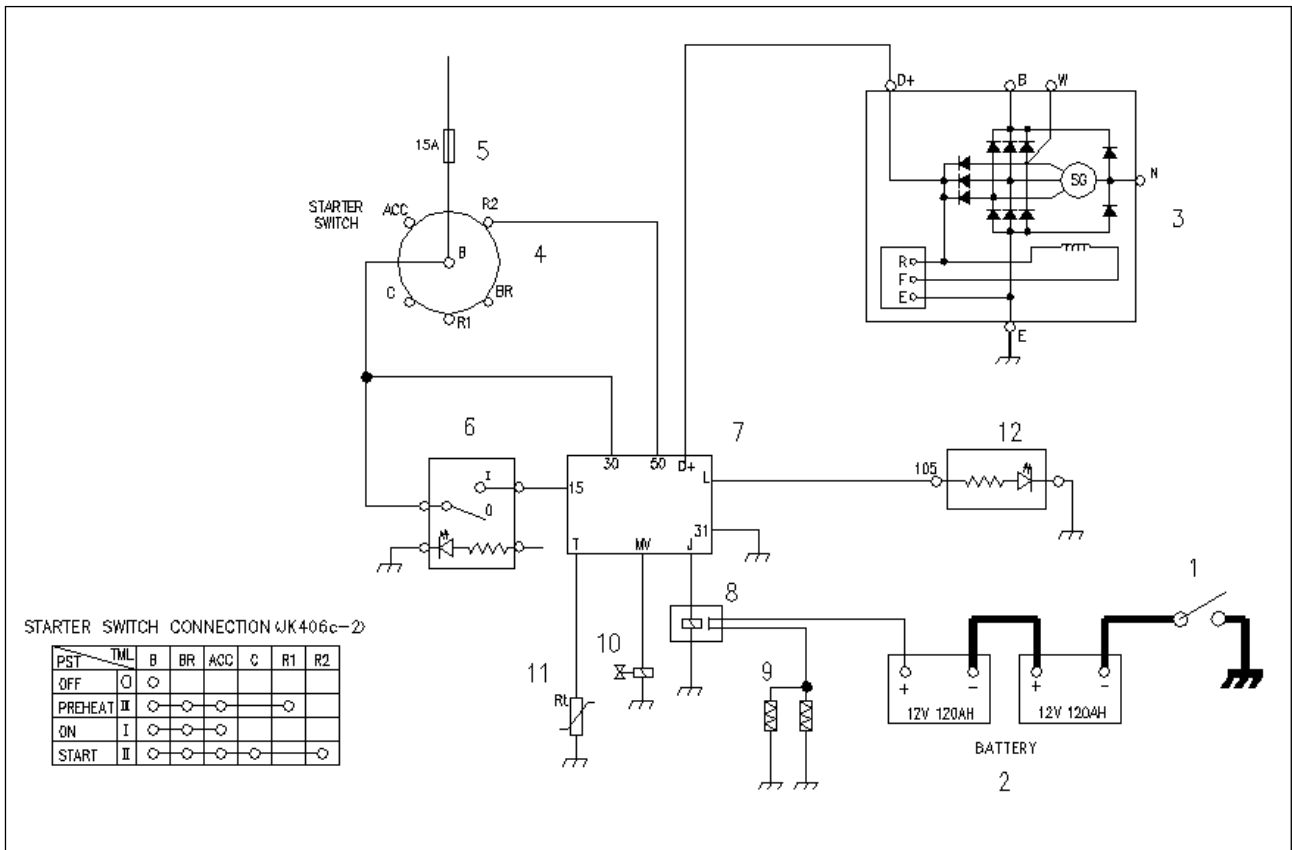

Figure 3 Control circuit of preheating system

Reference Number	Description	Reference Number	Description
1	Disconnect Switch	7	Preheat Controller
2	Battery	8	Preheat Relay
3	Alternator	9	Pre heater
4	Starter Switch	10	Solenoid Fuel Valve
5	Fuse	11	Water Temperature Sensor
6	Preheat Switch	12	Preheat Indicator

Charging System

Turn key switch (5) to "ON" position, its terminals "BR" and "B" are connected, power relay (6) acts, terminals "02A" and "02" are connected, electric current coming from storage battery (2) goes through fuse box (4), power relay (6), charging indication light (8) and excitation resistance (9) and reaches "D+" terminal of generator (5), earth connected and forms a circuit, charging indication light (8) is on to warn and supplies excitation electric current for generator (5). After engine is started, generator (5) starts charging. Electric current comes from terminal "B+" of generator (5), goes through fuse box (4) and reaches storage battery (2). Charging indication light (8) is off.

Generator (5) also supplies power to other electrical parts through fuse box (4) and power relay (6).

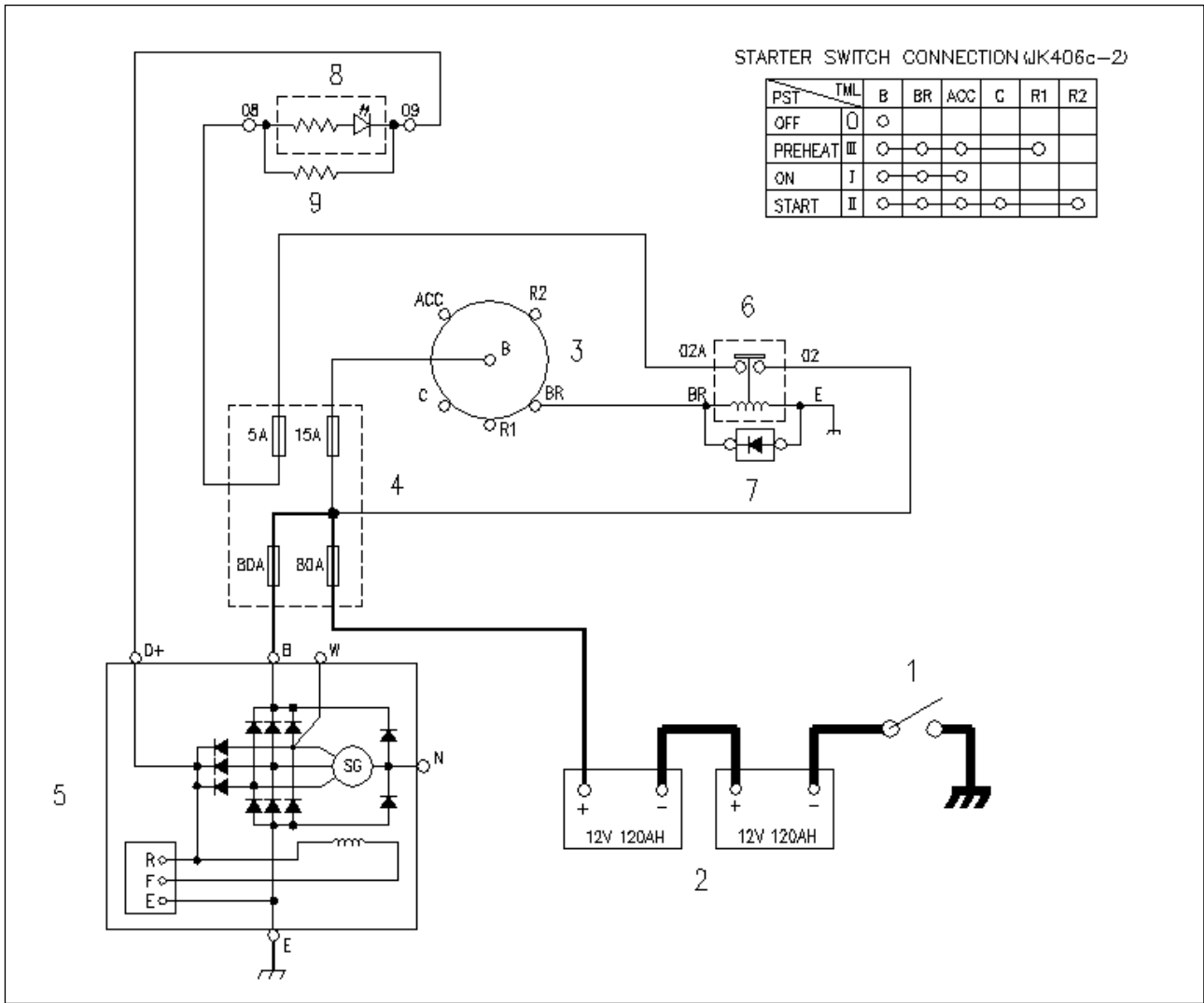

Figure 4 Charging system circuit diagram

Reference Number	Description	Reference Number	Description
1	Disconnect Switch	6	Battery Relay
2	Battery	7	Diode
3	Starter Switch	8	Charge Indicator
4	Fuse Box	9	Resistor
5	Alternator		

Monitoring System

Monitoring system of the equipment includes all kinds of oil pressure gauges, oil pressure sensor plug, water temperature gauge, water temperature sensor plug, voltmeter, barometer and low pressure warning device, etc. Five instruments on instrument panel are sensing types, one instrument is directly operated type.

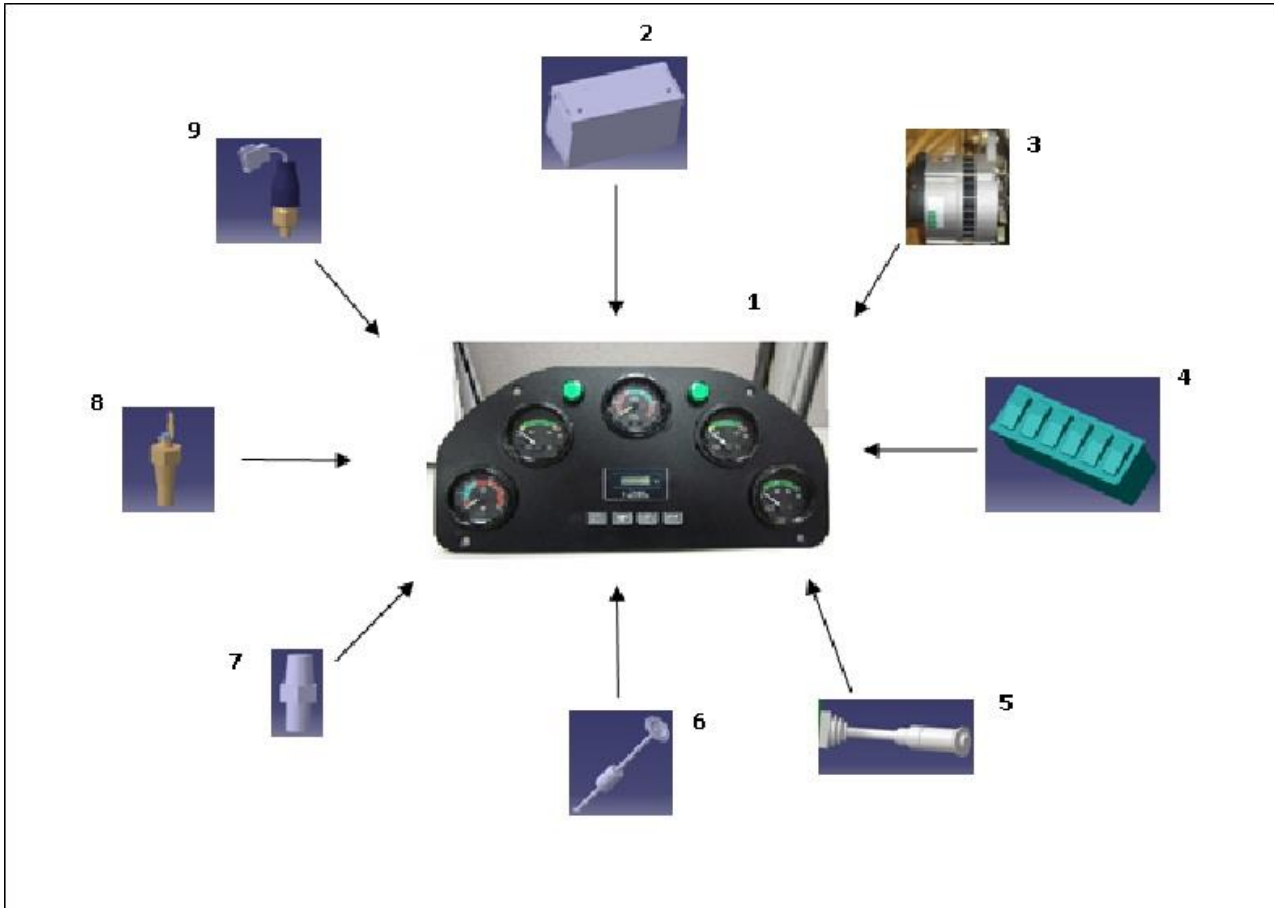

Figure 5 Monitoring system

Reference Number	Description	Reference Number	Description
1	Gauge Panel	6	Fuel Sensor
2	Battery	7	Oil Temperature Sensor
3	Alternator	8	Water Temperature Sensor
4	Rocker Switch	9	Back Buzzer Switch
5	Switchgroup		

Monitoring system will process information collected from all sensors, the instrument panel will indicate all data and warning signals.

Gauge panel

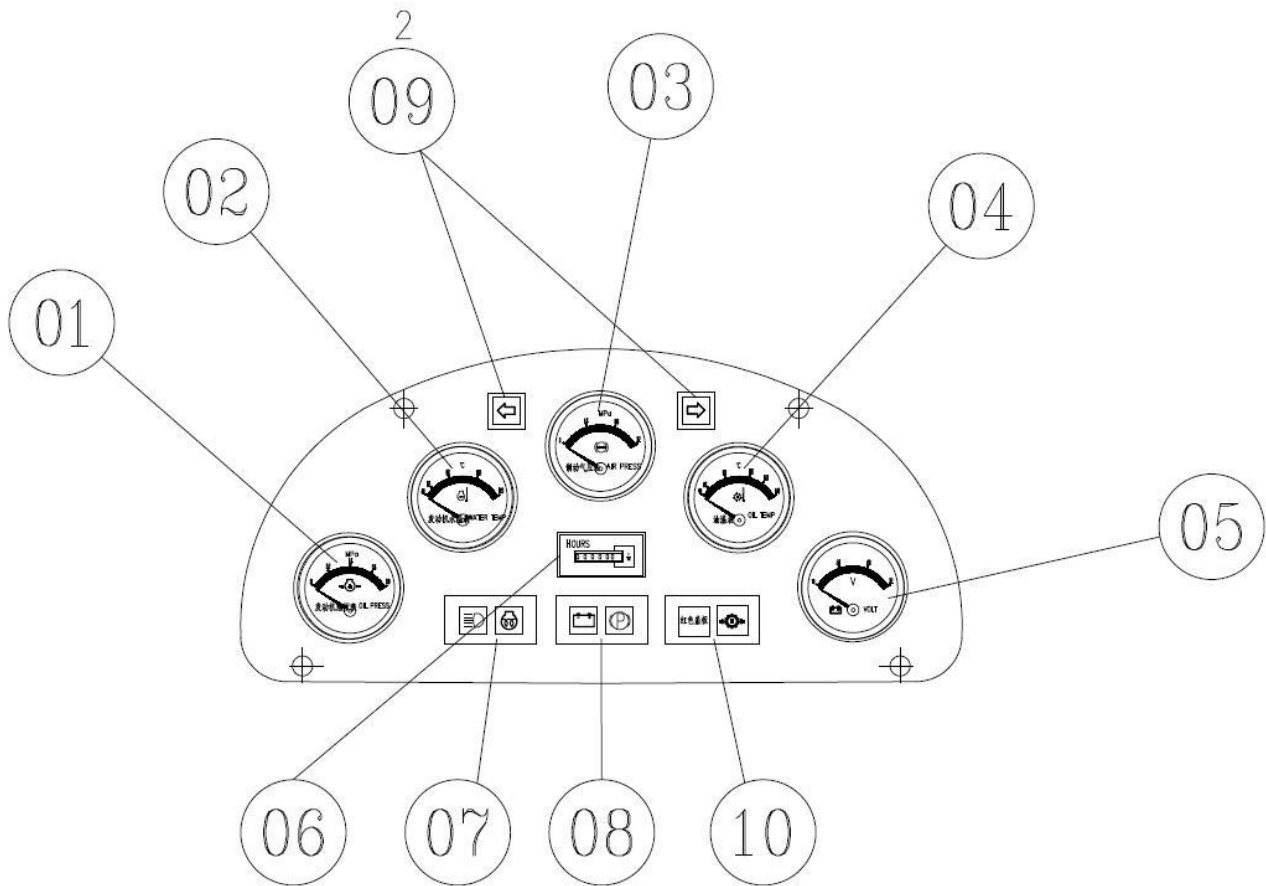
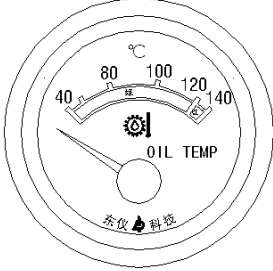
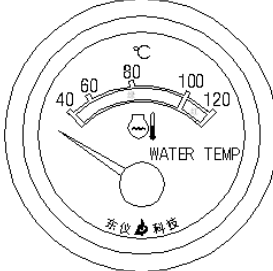
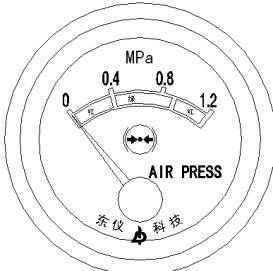
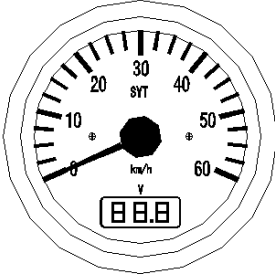
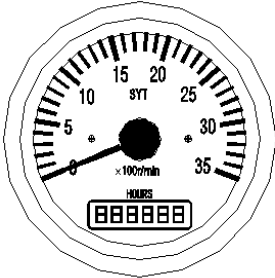

Figure 6 Gauge panel

Reference Number	Description	Reference Number	Description
01	Engine Oil Pressure Warning Light	08	Charging Warning Light
02	Engine Coolant Temperature Gauge	08	Air Pressure Warning Light
03	Air Pressure Meter	09	Turn and Hazard Warning Light
04	Torque Converter Oil Temperature Meter	10	Transmission Oil Pressure Warning Light
05	Voltmeter		
06	Hour meter		
07	High Beam Indicator		
07	Preheat Indicator		





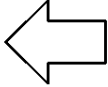
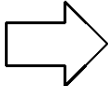
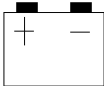

Instruments

Function	Display	Sensor Specification	
		Input Terminal	Input Specification
Oil temperature gauge of torque converter		CN-05	40°C — More than 180Ω 80°C — 40Ω ~ 60Ω 100°C — 20Ω ~ 40Ω 120°C — less than 20Ω 140°C — more than 10Ω
Water temperature gauge		CN-03	40°C — More than 180Ω 60°C — 80Ω ~ 100Ω 80°C — 40Ω ~ 60Ω 100°C — 20Ω ~ 40Ω 120°C — less than 20Ω
Brake barometer		Directly operated type	Directly operated type

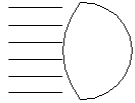
Function	Display	Sensor Specification	
		Input Terminal	Input Specification
voltmeter		CN-41	10 km/h — 531 Hz 20 km/h — 1060 Hz 30 km/h — 1593 Hz 40 km/h — 2124 Hz
Engine speed indicator & hour meter		CN-40	500 rpm — 107 Hz 1000 rpm — 214 Hz 1500 rpm — 321 Hz 2000 rpm — 428 Hz 2500 rpm — 535 Hz 3000 rpm — 642 Hz

Indication light

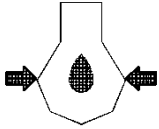
Function	Indication	Input terminal	Operation	Remark
	Turn left and dangerous indication light	CN-19	The light is on when turning left signal or dangerous warning light is turned on (the Max. terminal input is 24V)	
	Turn right and dangerous indication light	CN-18	The light is on when turning right signal or dangerous warning light is turned on (the Max. terminal input is 24V)	
	Charging	CN-08 CN-09	The light is on when not charging (Generator D + terminal output voltage reduces to 24V)	Under normal condition, light is on when starting, light is off when engine starts working

Function	Indication	Input terminal	Operation	Remark
	Headlights on full beam	CN-20	The light is on when headlight on full beam is turned on (The Max. terminal input is 24V)	
	Oil pressure of gear box	CN-11	The light is on when pressure decreases to 1.2Mpa.	
	Preheat	CN-105	The light is on when preheating system is working	
	Parking brake	CN-10	The light is on when brake switch is turned on (pressure switch is off when pressure is more than 0.3Mpa, the Max. input terminal is 24V)	When braking, the light is on before engine is started under any conditions.
	Engine fuel oil pressure	CN-12	The light is on when engine fuel oil pressure is less than 0.06Mpa.	
	Brake pressure	CN-08	The light is on when pressure reduces to 0.4Mpa.	Under normal condition, the light is on before engine is started, light is off once engine is running.

Schematic diagram of monitoring system

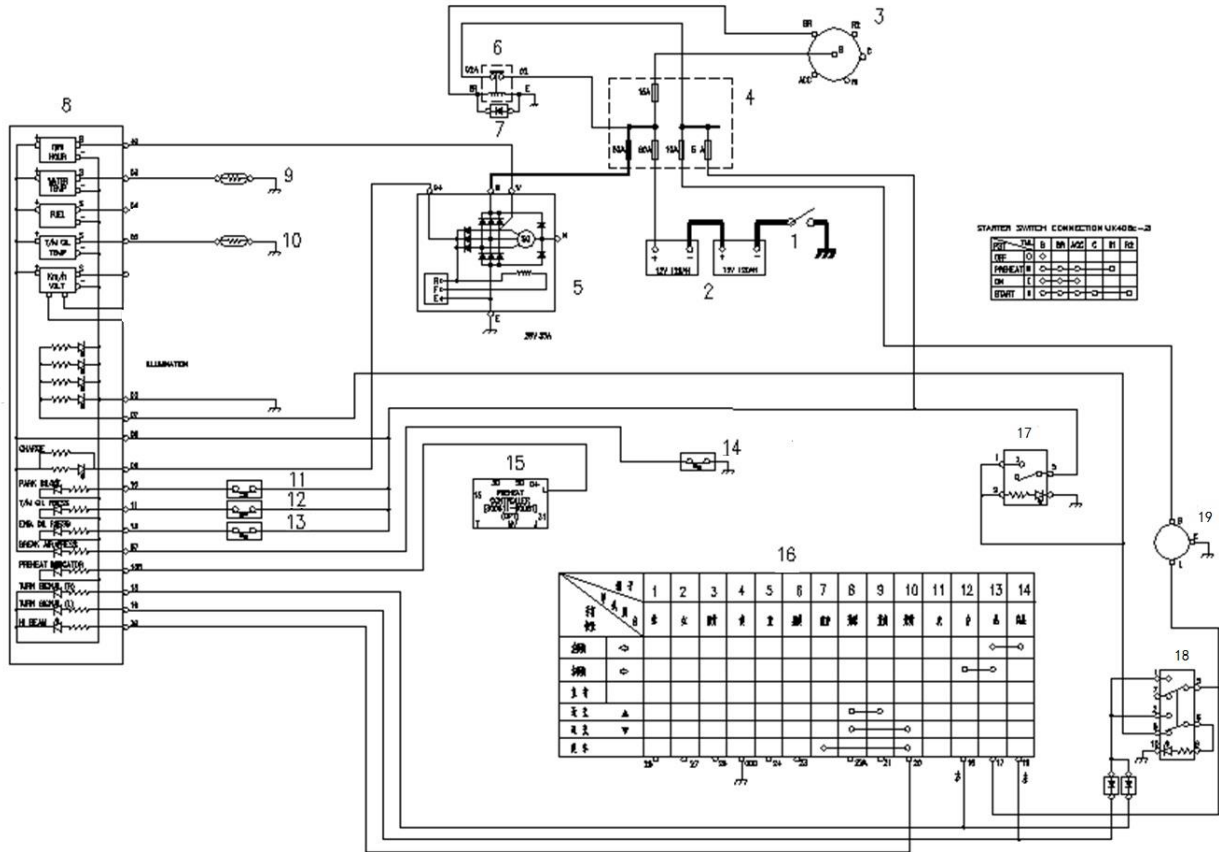

Figure 7 Schematic diagram of monitoring system

Reference Number	Description	Reference Number	Description
1	Disconnect Switch	12	Break Pressure Switch
2	Battery	13	Eng. Oil Pressure Switch
3	Starter Switch	14	Air Pressure Alarm Switch
4	Fuse Box	15	Preheat Controller
5	Alternator	16	Combination Switch
6	Starter Relay	17	Position Lamp Switch
7	Diode	18	Hazard Switch
8	Gauge Panel	19	Blinker Unit
9	Water Temperature Sensor		
10	Transmission Temp Sensor		
11	T/M Oil Pressure Switch		

Windshield Wiper

Windshield wiper can be operated by combination switch (2).

1. Low speed wiper (I gear)

When wiper is running with low speed, electric current comes from fuse box (1), goes through wire inlet terminal and terminal “L” of wiper motor (3), reaches terminal “6” and “4” of combination switch (2) and connects with earth.

2. High speed wiper (II gear)

When wiper is running with high speed, electric current comes from fuse box (1), goes through wire inlet terminal and terminal “H” of wiper motor (3), reaches terminal “1” and “4” of combination switch (2) and connects with earth.

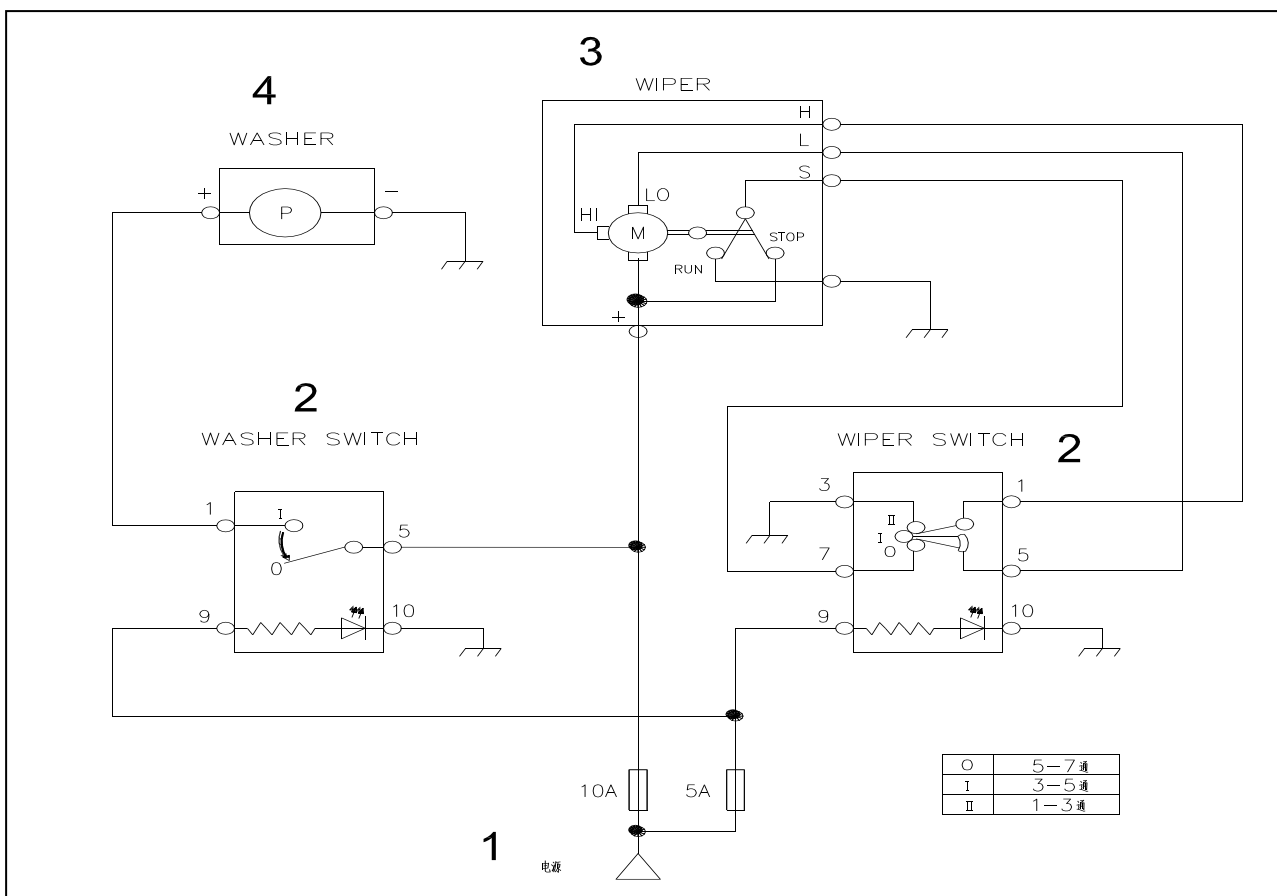

Figure 8 Circuit diagram of front windshield wiper

Reference Number	Description	Reference Number	Description
1	Fuse Box	3	Wiper
2	Rocker Switch	4	Washer

Lighting System

Lamping system includes main lamp, position lamp, turning signal lamp, dangerous lamp, parking lamp, working lamp and switches of all lamps.

1. When indoor lamp (4) is turned on, electric current goes to indoor lamp from fuse box (1), indoor lamp is on.
2. Press front lamp switch (18), combination switch (2) is turned to passing lamp, terminal "8" and "9" are connected, electric current from fuse box (1) is sent to coil terminal "86" of passing lamp relay (6), passing lamp relay (6) works, its terminal "30" and "87" are connected, passing lamp of front lamp(12) and (13) gets power and works.
3. Press front lamp switch (18), combination switch (2) is turned to distance lamp, terminal "8" and "10" are connected, electric current from fuse box (1) is sent to coil terminal "86" of distance lamp relay (5), distance lamp relay (5) works, its terminal "30" and "87" are connected, distance lamp of front lamp (12) and (13) gets power and works.
4. Combination switch (2) is turned to left handed rotation, its terminal "13" and "14" are connected, electric current from fuse box (1) goes through flasher (7), combination switch (2) and reaches left turning lamp of front combination lamp (12) and rear combination lamp (14).
5. Combination switch (2) is turned to right handed rotation, its terminal "13" and "12" are connected, electric current from fuse box (1) goes through flasher (7), combination switch (2) and reaches right turning lamp of front combination lamp (13) and rear combination lamp (15).
6. When brake switch (3) works, electric current from fuse box (1), reaches brake lamp of rear combination lamp (14) and rear combination lamp (15), brake lamp works.
7. When pressing switch of position lamp (17), its terminal "5" and "1" are connected. Electric current from fuse box (1) reaches small lamps of (10), (11), (16), (17), and (18), and front combination lamp (12) and (13), position lamp of rear combination lamp (14) and (15).
8. When pressing switch of working lamp (10), its terminal "5" and "1" are connected. Electric current from fuse box (1) reaches working lamp (9), working lamp is on.
9. When pressing rear lamp switch (11), its terminal "5" and "1" are connected. Electric current from fuse box (1) reaches working lamp (8), rear working lamp is on.
10. When pressing dangerous lamp (16), terminal "5" and "1", "2" and "37" are connected. Electric current from fuse box (1) is sent to turning lamp of front combination lamp (12) and (13), and rear combination lamp (14) and (15).

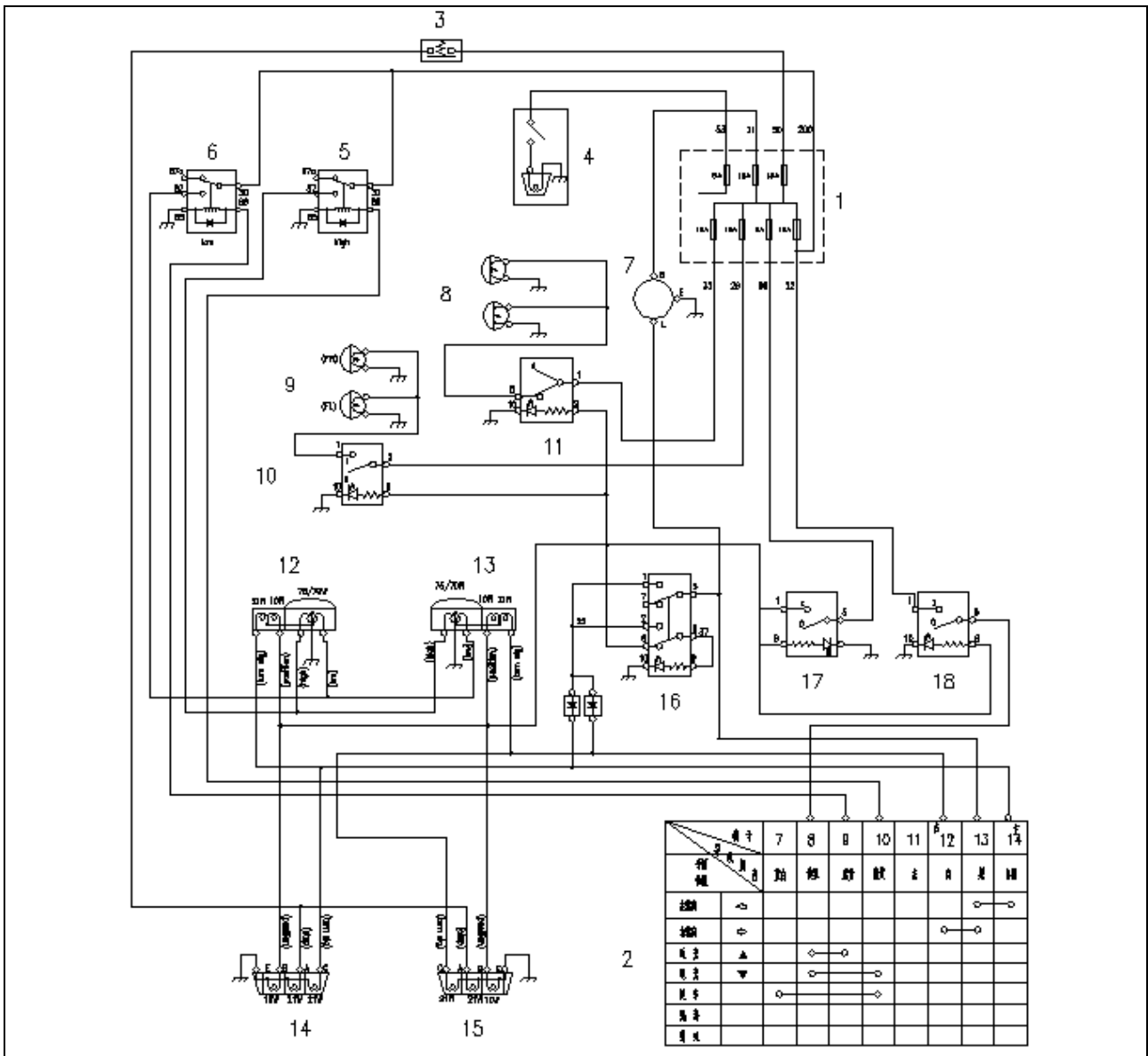

Figure 9 Lighting system circuit diagram

Reference Number	Description	Reference Number	Description
1	Fuse Box	10	Working Lamp Switch
2	Combination Switch	11	Rear Lamp Switch
3	Stop Lamp Switch	12	Front Combination Lamp(L)
4	Room Lamp	13	Front Combination Lamp(R)
5	High Lamp Relay	14	Rear Combination Lamp(L)
6	Low Lamp Relay	15	Rear Combination Lamp(R)
7	Blinker Unit	16	Hazard Switch
8	Rear Lamp	17	Position Lamp Switch
9	Working Lamp	18	Front Lamp Switch

Electric Detent System

Electric detent system includes swing arm lifting limitation system and cylinder automatic laid flat system.

Electric circuit

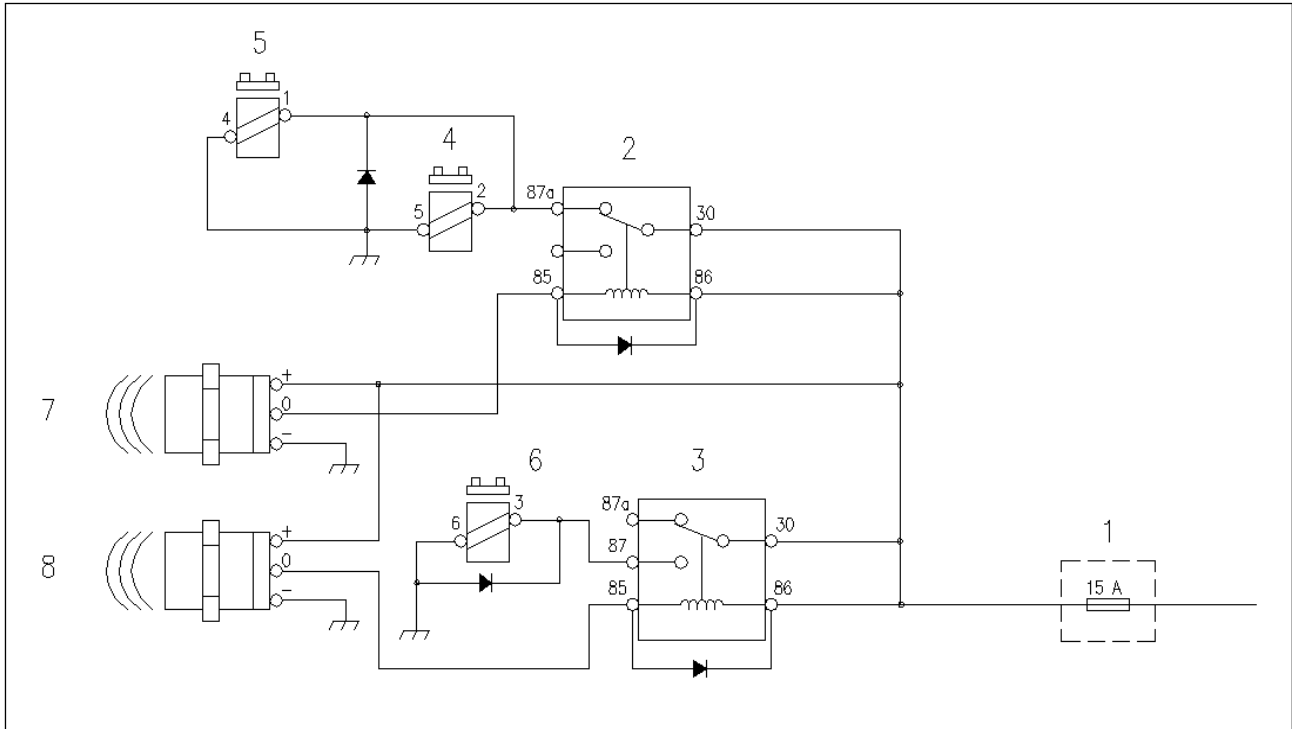

Figure 10 Electric detent system circuit

Reference Number	Description	Reference Number	Description
1	Fuse Box	5	Float Magnet
2	Raise Relay	6	Return to Dig Magnet
3	Return to Dig Relay	7	Proximity Switch 1
4	Raise Magnet	8	Proximity Switch 2

BOOM KICK-OUT

1. Swing arm lifting limitation

When swing arm operation handle is pulled to the rear limitation position, swing arm operation handle will be gripped by swing arm lifting electromagnet (4) (swing arm operation handle will not return to middle-position after loosening hands), swing arm will keep lifting; when swing arm reaches the limitation, proximity switch (7) works, its terminal "0" and "-" are connected, coil of lifting relay (2) is power on and works, its terminal "30" and "87a" disconnect. Lifting limitation electromagnet (4) and float electromagnet (5) are power off and lose suction ability, swing arm operation handle will return middle-position automatically with the effect of resetting spring, lifting hydraulic circuit of cylinder is cut off, and swing arm does not lift again.

2. Swing arm floating device

When swing arm operation handle is pushed to the limitation, swing arm operation handle will be gripped by swing arm floating electromagnet (5) (swing arm operation handle will not return to middle-position after loosening hands), at this moment, swing arm is at floating state, the swing arm operation handle will return middle-position when releasing swing arm floating state. When swing arm descends, it can be pushed to floating position, swing arm will descend with effect of dead weight. At this moment, the driver can operate other items (such as flat bucket) with the right hand, thus working efficiency is improved. Push swing arm operation handle to floating position during slicking, bucket will rise along with rising of ground, and will not damage the road.

RETURN TO DIG

When bucket is at material discharging state, pull bucket operation handle to rear limitation, since proximity switch (8) is at suction state, its terminal "0" and "-" are connected, automatic laid flat relay (3) coil is power on and pulls in, bucket operation handle is gripped by bucket collecting holding electromagnet (6) and keep at the rear limitation position (bucket operation handle will not return to middle-position after loosening hand), bucket will keep rotating backward until reaching limitation, proximity switch (8) acts, its terminal "0" and "-" are disconnected, automatic laid flat replay (3) is power off and disconnect, bucket collecting holding electromagnet loses power and gripping ability, bucket operation handle returns to middle-position with effect of resetting spring, bucket stops rotating, swing arm descends, when bucket reaches to the ground, bucket bottom is flat with the ground.

PROXIMITY SWITCH

Operating distance: $10\text{mm} \pm 1\text{mm}$

Operation indication light: Indication light is on when proximity switch is acting.

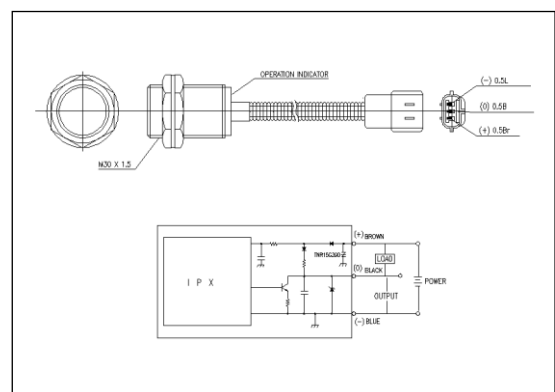

Figure 11 Proximity switch

SCHEMATIC

 **CAUTION!**

Follow all safety recommendations and safe shop practices outlined in the front of this manual or those contained within this section.

Always use tools and equipment that is in good working order.

Use lifting and hoisting equipment capable of safely handling load.

Remember, that ultimately safety is your own personal responsibility.

General Description

Schematic diagram shown in this section is shown in folio page.

The overlapped edge has been considered for convenient copy, a complete schematic diagram can be formed when they are put together.

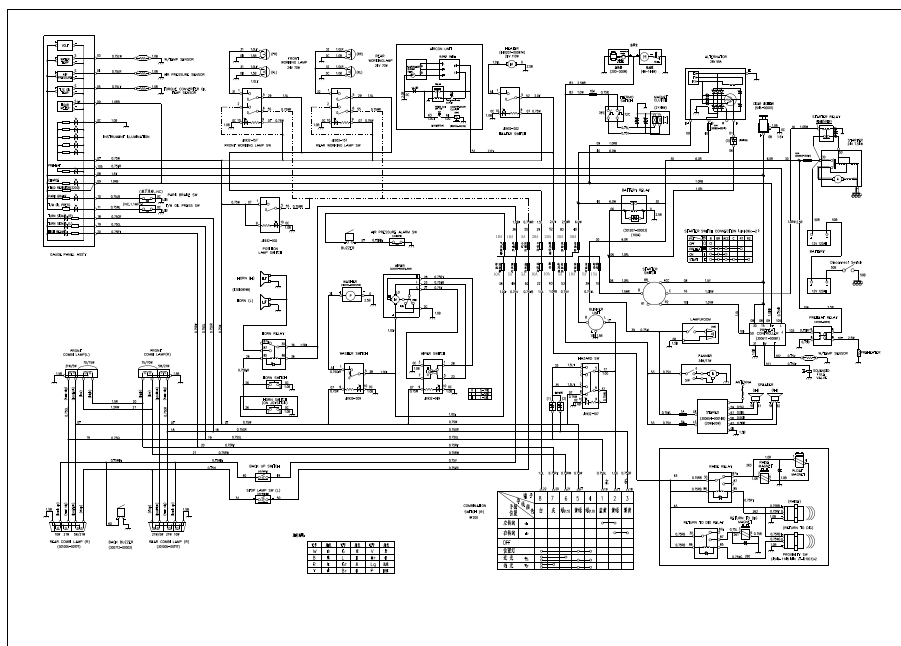
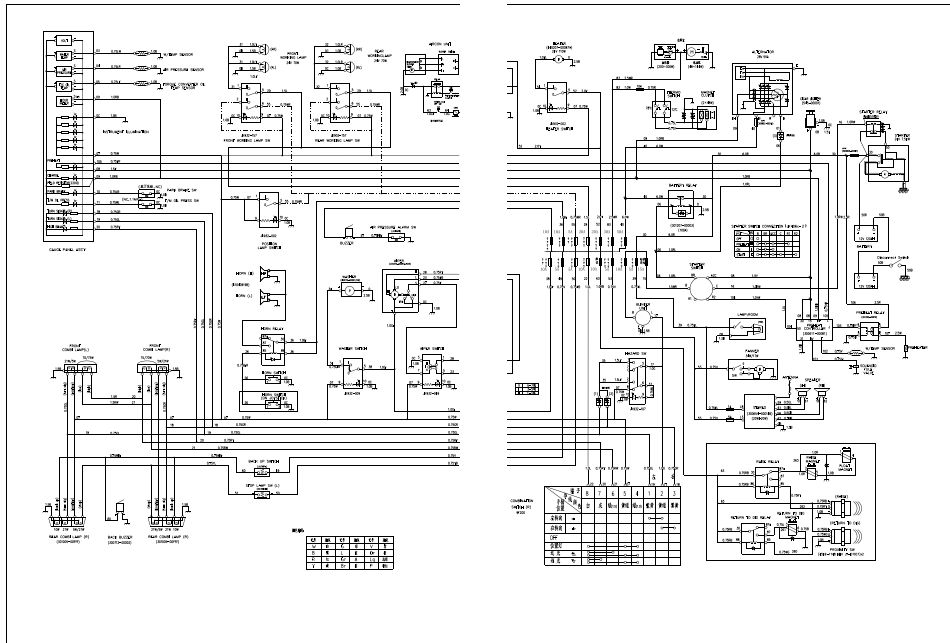

Figure 1

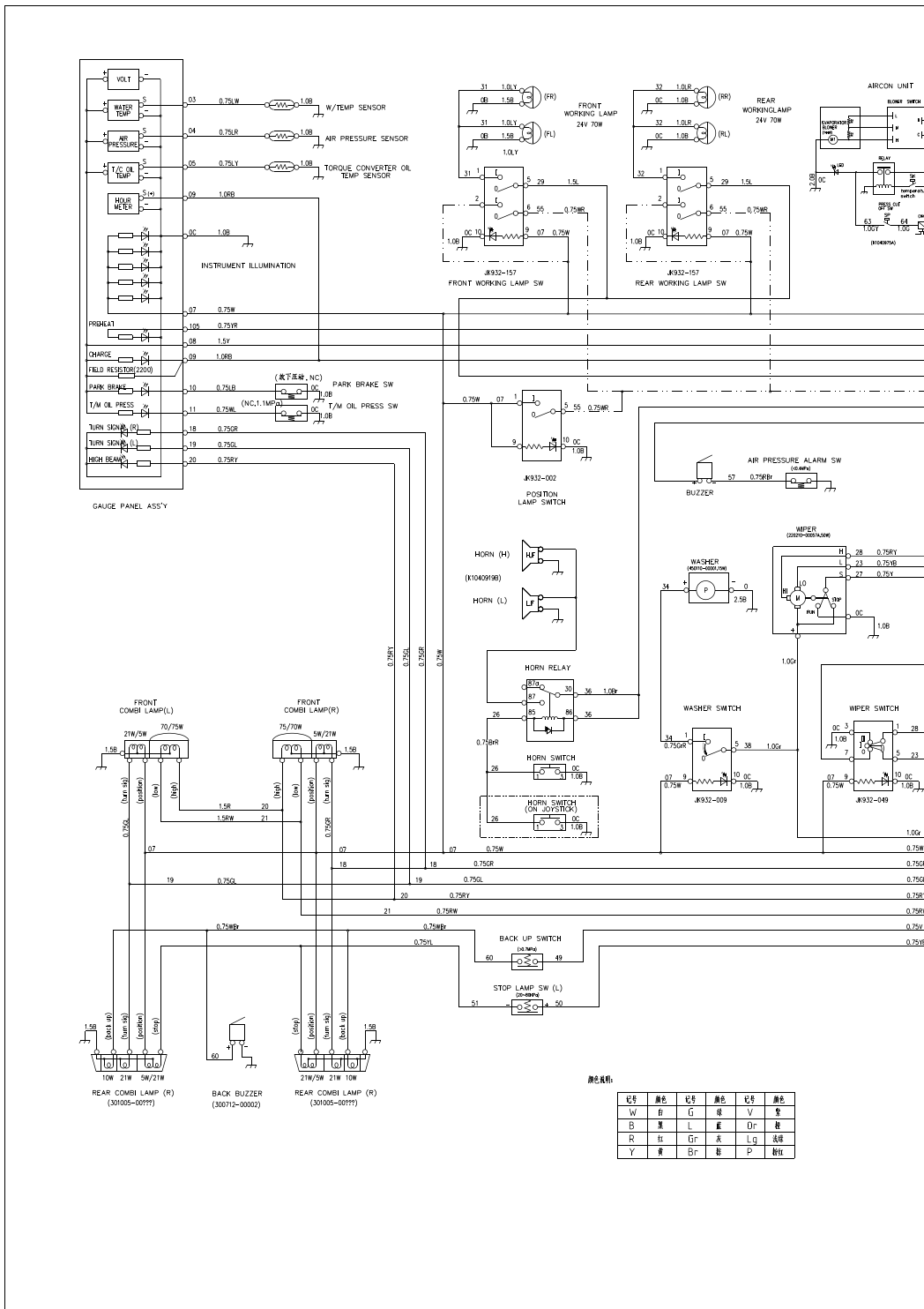

Figure 2

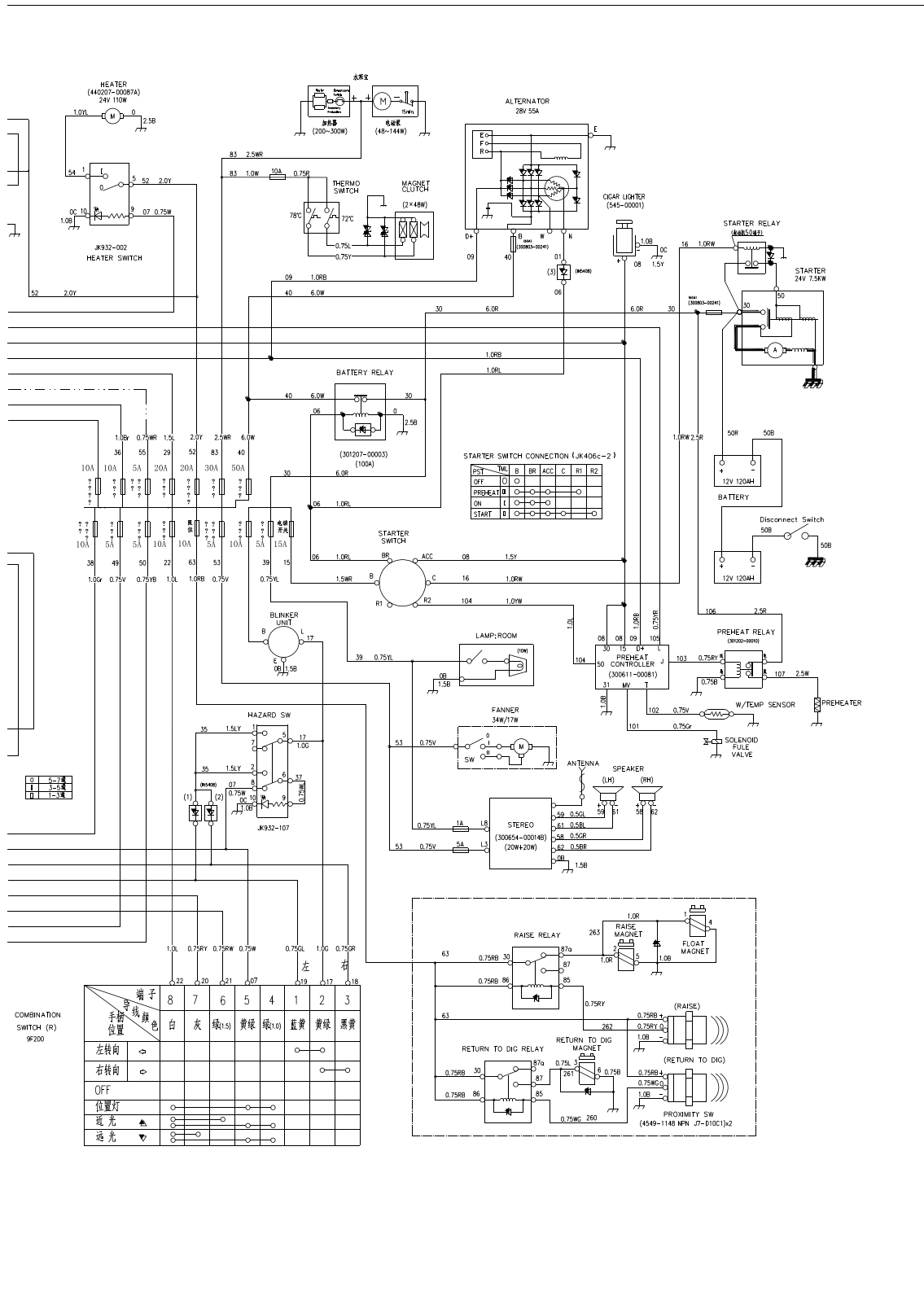

Figure 3

ATTACHMENTS