

Power system and start system	Fuel Warmer	Engine Stop	Horn	Brake light	Back Buzzer	Cluster, Parking, Brake low pressure, Alarm
-------------------------------	-------------	-------------	------	-------------	-------------	---------------------------------------------

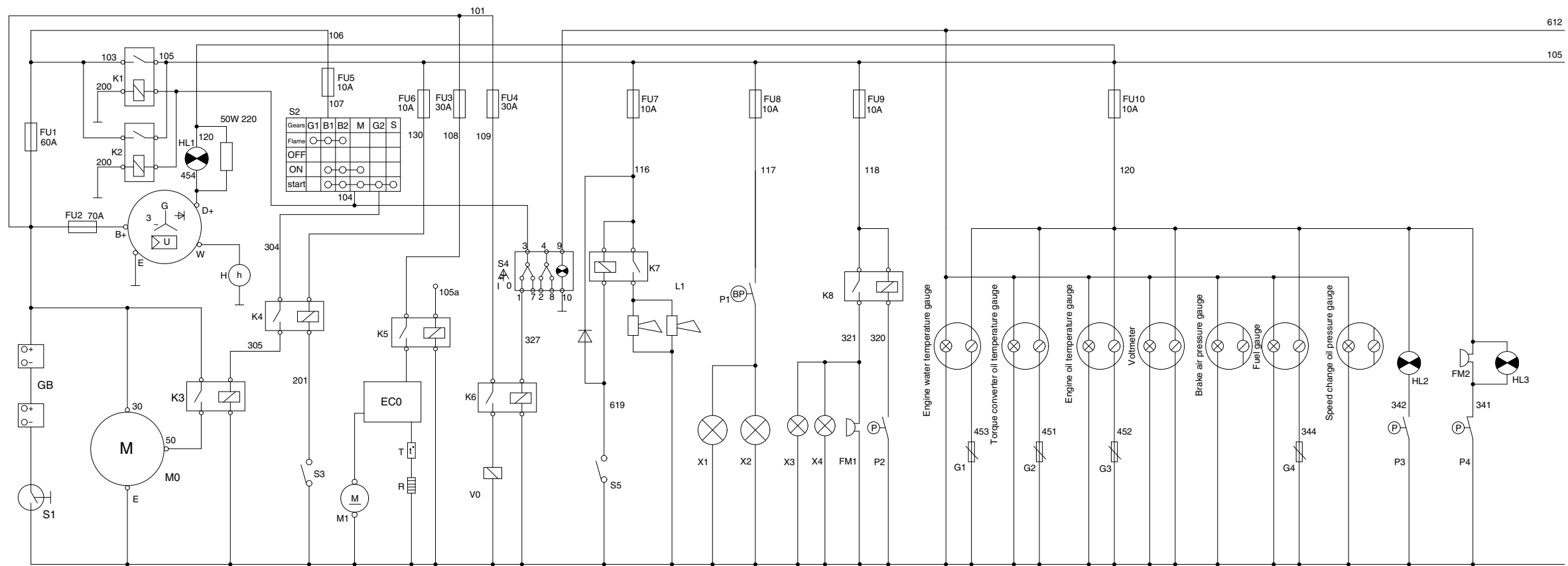

Turn light and emergency lights	Width lamp and head lamp	Front and rear work lights	Cab light Warning light	Fan, heater	Wiper motor	Pilot, control	Air conditioning Cigarette lighter	Preheating device
---------------------------------	--------------------------	----------------------------	-------------------------	-------------	-------------	----------------	------------------------------------	-------------------

