



950106-015008EN

# Operation & Maintenance Manual

**DIESEL INDUSTRIAL ENGINE**

**DL06P**



**WARNING:** Breathing diesel engine exhaust exposes you to chemicals known to the State of California to cause cancer and birth defects or other reproductive harm.

- Always start and operate the engine in a well-ventilated area.
- If in an enclosed area, vent the exhaust to the outside.
- Do not modify or tamper with the exhaust system.
- Do not idle the engine except as necessary.

For more information go to [www.P65Warnings.ca.gov](http://www.P65Warnings.ca.gov).



**WARNING:** This product can expose you to chemicals including lead, which is known to the State of California to cause cancer and birth defects or other reproductive harm.

For more information go to [www.P65Warnings.ca.gov](http://www.P65Warnings.ca.gov).

# Forward

This Operation and Maintenance Manual provides information on engine management and maintenance techniques to customers and technicians of Doosan Infracore's Tier4 Final DL06P electronically controlled industrial diesel engine.

To provide the best engine to our customers, the Tier4 Final DL06P electronically controlled industrial diesel engine is designed to satisfy all requirements for low noise, economic fuel consumption, high speed and durability with the latest technology and quality.

Exact operation and proper maintenance are essential for operating engines for an extended time with optimum conditions and best performance. This Operation and Maintenance Manual provides detailed descriptions of specifications, specified values, defect diagnosis, component diagrams, and drawings for easier and more precise understanding of the product and for proper maintenance and troubleshooting.

With the help of the recommended operation methods and procedures, high-level maintenance techniques and safety of workers can be ensured. Please read and understand this manual before working with our engines.

To ensure best performance and quality as well as to enhance maintenance techniques, Doosan Infracore is doing its best to continuously develop and invest. The design of our product may be changed without prior notice and Doosan shall not be held liable for the failure of this manual to contain all the design changes made to improve the product.

We, Doosan Infracore, do our best to provide more convenient and safe maintenance techniques and to meet the requirements of our customers.

If you have any questions or find any errors in this Operation and Maintenance Manual, please do not hesitate to contact us.

Thank you for purchasing our engine and we hope this Operation and Maintenance Manual be helpful for you.

2021. 01.  
950106-015008EN  
**Doosan Infracore**

\* Items exempted from warranty coverage

- Malfunctions resulting from failing to comply with the proper handling instructions, regular inspections, and machine storage techniques specified in the user manual
- Malfunctions resulting from failing to have the machine repaired at a designated dealer or center, or resulting from the use of non-genuine parts
- Malfunctions resulting from unauthorized modifications, changes, or external hardware
- Malfunctions resulting from incorrect operation by the user, delayed repairs, accidents, and natural disasters

\* The contents of this operation and maintenance manual are the exclusive property of Doosan Infracore. Any unauthorized reproduction, printing and distribution thereof are strictly prohibited.



# Table of contents

<b>1. General introduction .....</b>	<b>1</b>
General information .....	3
Danger, warning, caution and note .....	4
Engine maintenance .....	7
<b>2. Operation and maintenance .....</b>	<b>9</b>
Starting and stopping of the engine .....	11
Break-in period of the engine .....	12
Operation in winter .....	14
Inspection and repair of the engine .....	15
<b>3. Performance and specifications .....</b>	<b>17</b>
Engine specifications and performance .....	19
Outside drawing of the engine (DL06-LEE00/03/04/06/07/08/11/12/14/15/17/19/20/22) .....	44
Outside drawing of the engine (DL06-LEE01/09) .....	47
Outside drawing of the engine (DL06-LEE02/10/18) .....	50
Outside drawing of the engine (DL06-LEE05/13/21) .....	53
Outside drawing of the engine (DL06-LEF00/01) .....	56
Outside drawing of the engine (DL06-LEL00/01) .....	59
Outside drawing of the engine (DL06-LEL04/05/06) .....	62
Engine identification number .....	65
<b>4. Regular inspection .....</b>	<b>67</b>
General information .....	69
Regular inspection table .....	70
Cooling system .....	71
Lubrication system .....	75
Fuel system .....	80
Intake/Exhaust system .....	81
Cylinder block/head .....	84
Electric system .....	87
Others/Driving system .....	88
<b>5. About the engine .....</b>	<b>89</b>
Marking system of units .....	91
Tightening torque .....	92
Engine disassembly .....	96
Engine assembly .....	109

<b>6. Cooling system .....</b>	<b>129</b>
General information .....	131
Thermostat .....	133
Cooling fan .....	134
<b>7. Lubrication system .....</b>	<b>135</b>
General information .....	137
Oil pump .....	139
<b>8. Fuel system .....</b>	<b>141</b>
General information .....	143
Injector .....	145
Common rail .....	147
Fuel injection pump .....	149
Fuel feed pump .....	151
<b>9. Intake/Exhaust system .....</b>	<b>153</b>
General information .....	155
Turbocharger .....	156
EGR (Exhaust Gas Reduction) system .....	168
Intake pipe .....	171
<b>10. Cylinder block/head .....</b>	<b>173</b>
General information .....	175
Cylinder block .....	176
Cylinder head .....	177
Valve .....	179
Rocker arm .....	182
Tappet and push rod .....	184
Camshaft .....	185
<b>11. Electric system .....</b>	<b>187</b>
Circuit diagram .....	189
Switches and sensors .....	196
ECU (Electronic Control Unit) .....	203
Starter .....	206
Exhaust gas reduction .....	208

<b>12. Others/Driving system</b> .....	<b>213</b>
General information .....	215
Crankshaft .....	216
Piston .....	220
Connecting rod .....	222
Others .....	223
<b>13. Aftertreatment system</b> .....	<b>225</b>
Exhaust gas reduction .....	227





# 1. General introduction

General information .....	3
General information .....	3
Danger, warning, caution and note .....	4
General information .....	4
General instructions .....	4
Cautions for starting the engine .....	4
Cautions for inspection and repair .....	4
General repair .....	5
Other safety instructions and environmental pollution .....	6
Use of genuine parts .....	6
Engine maintenance .....	7
Prevention of damage and abrasion .....	7
Prevention of pollution .....	7
Handling of engine oil .....	7
Biodiesel blend fuel .....	8



## General information

### General information

This Operation and Maintenance Manual provides the most efficient methods for engine maintenance as well as quick, efficient methods to determine the cause of engine faults to ensure that any actions taken by professionally certified maintenance technicians are done in the most efficient and efficient way possible. If maintenance is performed by unskilled technicians, or maintenance without the specified tools and facilities, serious bodily injury or critical faults in engine performance may occur.

Regular inspection and maintenance are required to maintain long-term optimal engine conditions and best performance. In the event that a part must be replaced, only genuine parts as defined by the parts the list (PARTS BOOK) should be used. Doosan shall not be held liable for any critical damage or faults which may be caused by the use of unauthorized or remanufactured parts.

The maintenance methods stated in this Operation and Maintenance Manual are the most efficient and safest work procedures. Some work procedures require special tools.

For questions about genuine parts and special tools, please contact us.

This Operation and Maintenance Manual includes 'Danger,' 'Warning,' and 'Caution' in order to reduce possible injuries and engine faults which may occur while performing maintenance. If workers do not follow the instructions, critical faults in engine performance and operation or serious bodily injury may occurred. 'Danger,' 'Warning,' and 'Caution' instructions must be followed. However, we inform you that it is not possible to describe all possible and unexpected dangers which may arise while performing engine maintenance.

# 1. General introduction

---

## Danger, warning, caution and note

### General information

This Operation & Maintenance manual divides maintenance operations such as performing engine checks, troubleshooting, or diagnosing faults into three categories, "Danger," "Warning," and "Caution." In addition, **Note** is used to provide additional descriptions and information required for maintenance technicians to successfully operate our engines. The recommended repair methods and 'Danger,' 'Warning,' and 'Caution' can enhance the degree of completion of engine maintenance and prevent bodily injury which may occur to workers. However, this manual cannot predict all possible risks.

---

### **DANGER**

---

**Workers must observe instructions, otherwise fatal or serious injuries to workers and other persons may occur.**

---

---

---

### **WARNING**

---

**Workers must follow this instruction as failing to do so may result in the death or serious bodily harm of workers or others.**

---

---

---

### **CAUTION**

---

**Workers must observe this instruction since failing to do so may cause critical faults which can have impact on the engine performance and operation.**

---

---

Note) Indicates additional description, information, and references for workers' easy understanding.

### General instructions

1. In order to maintain the best long term performance and safety, please read and understand this manual and execute routine inspections and regular inspections.

2. We have divided the content of this manual into causes of bodily injury and damage to assets and causes of pollution.

---

### **WARNING**

---

**When a safety accident, such as skin contact with corrosive acids or fuel, burns with hot oil, exposure of eyes to fuel or antifreeze, occurs while starting, inspecting, or repairing an engine, see a doctor immediately.**

---

### Cautions for starting the engine

1. Before starting the engine, please read this manual carefully and fully understand 'Danger,' 'Warning,' and 'Caution'. If you cannot fully understand it or have any question, please contact us.
2. For safety reasons, attach "Warning" signs around engines in operation to keep people other than workers from accessing the engines. Let engine operators know that they are responsible for the safety of the engine room.
3. Only authorized people may start and operate engines. Unauthorized people should not be allowed to handle engines.
4. Do not access running or rotating parts while the engine is in operation.
5. Be careful not to touch or contact the engine during operation since it becomes hot during operation.
6. Exhaust gas is poisonous. Fully ventilate before starting engine. If the space is airtight, ensure that it is well ventilated.

### Cautions for inspection and repair

1. Inspection and repair of engine should be performed only when the engine is stopped. Otherwise, burns or safety accidents may occur, so do not perform inspection or repair while the engine is running.
2. If it is absolutely necessary to perform inspection or repair on the operating engine, do not get close to the rotating parts.

---

### **DANGER**

---

**When accessories such as necklaces, rings, watches, or gloves become stuck in rotating parts while the engine is running, serious bodily injury may occur.**

---

---

## WARNING

---

**Do not exchange or disassemble a pipe or hose (from the engine fuel circuit, engine oil circuit, coolant circuit, or compressed air circuit) while the engine is running. The leaked liquid may cause bodily injuries.**

---

3. Use an engine oil drain container that is large enough to prevent the overflow of engine oil while draining engine oil.
  4. Open the engine coolant cap after fully cooling the engine to exchange or replenish coolant.
- 

---

## WARNING

---

**If the coolant cap is opened while the engine is still hot, hot water will spurt out and may cause burns. Open the engine coolant cap after fully cooling the engine.**

---

5. Fuel is highly flammable. Smoking or use of fire around an engine may cause fire.
- 

---

## WARNING

---

**Only refuel when the engine is stopped.**

---

6. Mark and separately manage the containers for storing coolant from beverage containers for avoiding confusion. See a doctor immediately in case of drinking coolant.
  7. Follow the instructions provided by the battery manufacturer when checking or handling batteries.
- 

---

## WARNING

---

**Battery fluid is corrosive and dangerous because of its explosiveness and toxicity. Therefore, it should only be handled by a skilled technician who specializes in battery fluid.**

---

8. Only certified professional technicians should repair and maintain engines.
  9. Only appropriate tools should be used. If the jaws of a wrench are worn out, the wrench might slip during use, causing safety accidents.
  10. Do not allow other persons to stay or pass under an engine when lifting the engine with a crane. Before lifting the engine, ensure that there is no one around the engine and reserve enough safety space.
- 

11. Before inspecting or replacing the electrical apparatus, disconnect the battery ground wire first. Connect the battery ground wire after completing all required work for checking or replacing the electrical apparatus in order to prevent a short circuit.
12. Before performing electric welding works, turn off engine, block the power supply to the engine, and remove the wire harness connector connected to the engine control unit (ECU).
13. Do not give any electric or mechanical shocks or perform welding works on the electrical apparatus or the ECU.

### General repair

1. Wait until the engine is properly cooled down before starting work, since you may get burned by the heated engine.  
Before performing fuel line work, check the common rail pressure and engine temperature by using the failure diagnosis device.
2. Disconnect the battery ground wire from to prevent damage of wires and sensors caused by a short circuit.
3. Engine oil and coolant may damage paint and should be stored in a separate container and marked for safe management.
4. Store the disassembled parts in a specified space to avoid damage or pollution.
5. Use specified and special tools for efficient and safe repair.
6. If parts need to be replaced, use only genuine parts for replacement. Using unauthorized or remanufactured parts may cause critical damage and faults in engine performance.
7. Replace parts such as cotter pins, gaskets, O-rings, seal rings, oil seals, and washers with new ones during repairs. Reuse of parts may be the cause of engine faults and engine may not operate properly.
8. Group and store disassembled parts in disassembling order. The strength, shape, and screw torque of bolts and nuts are different according to their assembly position. Please divide and store them accordingly to these characteristics.
9. Clean disassembled parts to remove foreign substances before inspecting or reassembling parts. Use compressed air to clean the oil holes or holes.
10. Thinly spread oil or grease on rotating parts or parts requiring lubrication, before assembling them.
11. If required, use a specified adhesive to assemble gaskets to prevent water or oil from leaking.
12. Assemble bolts and nuts with the specified tightening torque.

# 1. General introduction

---

13. After completing repairs, conduct a final inspection and perform a test operation to check if all works have been successfully completed.

## Other safety instructions and environmental pollution

Observe the following instructions to protect workers from danger and to prevent the environmental pollution while performing engine repairs.

1. Good ventilation and low humidity should be maintained in the work space.
2. The workspace should be clean, in good order, and no flammables are allowed in the workshop.
3. Smoking is strictly forbidden in the workshop.
4. Workers should wear working clothes, protective goggles, and safety shoes.
5. Workers are not allowed to wear accessories such as necklaces, rings, watches, and earrings.
6. Start the engine in a well-ventilated space and fully ventilate the space before starting engine to prevent carbon monoxide poisoning.
7. Wait until the engine is properly cooled down before starting work, since you may get burned by the heated engine.
8. Do NOT work on rotating or running parts once the engine has been started.
9. Discard oil according to the regulations set forth by the relevant authorities.
10. If engine oil or fuel leaks on the floor or is improperly discharged, serious environmental pollution of sea, river or underground water may occur.
11. Discard the undiluted anticorrosive agent, antifreeze, filter elements, and cartridges as special wastes.
12. Discard coolant and special waste according to the regulations of the appropriate authorities.

## Use of genuine parts

An engine consists of many parts which are mechanically harmonized. To prevent engine faults in advance and use engines with best performance for a long period, maintenance and replacement of expendable parts should be conducted regularly.

Use of genuine parts is recommended. Using unauthorized or remanufactured parts may cause critical damage and faults to engine for which Doosan shall not be held liable.

---

## **WARNING**

---

**Failure to observe the regulations of the relevant authorities violates environmental pollution regulations and may be subject to legal penalties.**

---

## Engine maintenance

### Prevention of damage and abrasion

Using an engine for any purposes other than the designed purpose may cause critical faults in engine performance for which Doosan shall not be held liable. For details concerning the usage and purpose of the engine, please direct questions to our Sales Team. Do not adjust, convert, or change the ECU without our authorization.

If a problem is found in an engine, figure out and solve the cause to prevent the critical faults in advance.

Use of genuine parts is recommended. Using unauthorized or remanufactured parts may cause critical damage and faults to engine for which Doosan shall not be held liable. Consider the following while managing engines.

1. Use clean, specified, and qualified fuel only. Use fuel recommended in this Operation and Maintenance Manual.

---

### CAUTION

---

**Using inappropriate or unspecified fuel may cause critical damage and faults in engine performance.**

---

2. Do not operate an engine without lubrication oil or coolant. Use only the products (engine oil, cooling water, anticorrosive agent, and etc) recommended by Doosan.
3. Always keep surroundings of the engine clean.
4. Use fuel recommended in this Operation & Maintenance manual.
5. Conduct inspections and exchanges regularly according to the regular inspection table.
6. If the engine is overheated, do not stop it immediately, but operate it at idle status for five minutes or more to lower the engine temperature to the proper level.

---

### WARNING

---

**If the radiator cap is opened while the engine is still hot, hot water will spurt out and may cause burns.**

---

7. Check the engine oil level on a flat surface. Do not exceed the maximum on the oil level gauge.

---

### CAUTION

---

**Immediately replenish engine oil when the engine oil level is below the lower limit of the engine oil gauge.**

---

8. If there are gauges for battery, oil pressure and coolant and temperature, check if they indicate a normal status.

9. Do not operate engine without coolant.

---

### CAUTION

---

**Always use coolant mixed with antifreeze. If coolant without antifreeze is used, the coolant may freeze causing the coolant passage in the cylinder block to freeze and damaging the engine.**

---

### Prevention of pollution

Consider the following to manage engine without causing environmental pollution.

1. Discharge oil and coolant using collection containers.
2. Discard oil and coolant according to the regulations of the relevant authorities.
3. Be careful not to let discharged oil and cooling water flow into the ground or the sewer. Otherwise, serious pollution of the drinking water source may occur.
4. Classify the oil, filters, and filter cartridges as environmental pollution wastes and discards them according to regulations.
5. Classify the antifreeze, cooling water, and anticorrosive agent as hazardous wastes and discards them according to the regulations.

### Handling of engine oil

Prolonged and repeated contact of skin with engine oil may cause skin to dry out and contract, causing dermatitis.

Engine oil includes substances toxic to the human body.

Handle engine oil by observing the following safety rules:

1. Do not expose skin to new engine oil for a long time.
2. Always wear working clothes and gloves.
3. If skin comes in contact with engine oil, immediately wipe it off with water, soap or hand cleaners.
4. Do not clean skin with gasoline, fuel, thinner, or solvent.
5. Apply a skin protective cream after cleaning from oil.
6. Do not put oil-stained gloves or cloth in ones pocket.

---

### WARNING

---

**Discard oil according to the regulations set forth by the relevant authorities. Disposing of discharged oil into the ground, sewers, drains, rivers, or the sea will cause serious environmental pollution. Violation of regulations regarding discard of engine oil without observing the handling regulations, will be punished.**

---

# 1. General introduction

---

## Biodiesel blend fuel

Note) Biodiesel blend fuel may also be used in this machine.

Biodiesel blend fuel must contain no more than five percent biodiesel mixed with ultra low sulfur petroleum based diesel.

This biodiesel blend fuel is commonly marketed as B5/B7 (US/EU) blended diesel fuel. B5/B7 (US/EU) blended diesel fuel must meet ASTM D975 (US Standard) or EN590 (EU Standard) specifications.

Biodiesel blend fuel unique qualities that should be considered before using in engine

- Cold weather conditions can lead to plugged fuel system components and hard starting.
- Biodiesel blend fuel is excellent medium for microbial growth and contamination that can cause corrosion and plugging of fuel system components.
- Use of biodiesel blend fuel may result in premature failure of fuel system components, such as: plugged fuel filters and deteriorated fuel lines.
- Shorter maintenance intervals may be required, such as: cleaning the fuel system and replacing fuel filters and fuel lines.
- Using biodiesel blended fuels containing more than five percent biodiesel can affect engine life and cause deterioration of hoses, tubelines, injectors, injection pump, and seals.

Apply the following guidelines if biodiesel blend fuel is used:

- Ensure the fuel tank is as full as possible at all times to prevent moisture from collecting in the fuel tank.
- Ensure that the fuel tank cap is securely tightened.
- Biodiesel blend fuel can damage painted surfaces, remove all spilled fuel from painted surfaces immediately.
- Drain all water from the fuel filter daily before operating the engine.
- Do not exceed engine oil change interval. Extended oil change interval can cause engine damage.
- Before vehicle storage: drain the fuel tank, refill with 100% petroleum diesel fuel, add fuel stabilizer, and operate the engine for at least 30 minutes.

Note) Biodiesel blend fuel does not have long term stability and should not be stored for more than 3 months.



## 2. Operation and maintenance

Starting and stopping of the engine .....	11
Preparing for start .....	11
Starting the engine.....	11
After starting the engine.....	11
During operation .....	11
Stopping the engine .....	11
Break-in period of the engine .....	12
General information .....	12
Break-in period of a new engine .....	12
Check points .....	12
Operation after Break-in.....	12
Inspection after starting the engine.....	12
Engine oil pressure .....	13
Coolant temperature .....	13
Revolutions per minute (rpm).....	13
Operation in winter .....	14
Cold start.....	14
Preventing coolant from freezing .....	14
Preventing overcooling of the engine.....	14
Engine oil .....	14
Inspection and repair of the engine .....	15
Checking engine parts after prolonged operation .....	15
Inspection and repair of turbocharger .....	15
Intake unit .....	15
Exhaust unit .....	15
Lubrication system .....	15



### Starting and stopping of the engine

#### Preparing for start

Check the following before starting the engine for the first time after purchase.

1. Before starting an engine, check the levels of fuel, coolant, and oil and replenish those fluids if required.
2. Check if engine oil level is between the upper and lower limit of the oil level gauge. The upper and lower limit of the oil level gauge indicate the maximum and minimum of the engine oil level.

---

#### CAUTION

---

**When replenishing engine oil, do not exceed the maximum on the oil level gauge. Too much oil may cause damage to the engine.**

---

3. Be careful not to mix foreign substances in fuel, engine oil, or coolant while adding the fluid, and keep the fluid clean while it is not in use. Use fuel, oil, and coolant recommended by Doosan. Otherwise, critical damage to the engine may occur.

#### Starting the engine

Observe the following when starting the engine.

1. For a cold start, start the engine after preheating it sufficiently through the glow plug.
2. Starting the engine too quickly leads to engine rotation without lubricating the turbocharger and other engine parts, causing abnormal wear to or burning of bearings. Therefore, start the engine with the starter motor to check raising of oil pressure (until the gradation of the oil pressure gauge mounted on the apparatus moves or the pressure indicator lamp is turned on).
3. If the engine was not used or kept cold for a long period of time, oil circulation will be poor. If you replace oil, oil filter cartridge, or lubrication system parts or use an engine in cold areas, or the engine has been stopped for a long period, loosen the oil pipe joint at inlet of the turbocharger and run the starter motor until oil flows out. After completing the work, tighten the oil pipe joint again and start the engine.

#### After starting the engine

1. Do not rapidly raise the rpm while the engine and turbocharger do not rotate smoothly after starting the engine. Otherwise, it may increase the load upon the engine and burning may occur at the positions that have not been sufficiently lubricated yet. To prevent this, rotate the engine at idle after starting it to lubricate the turbocharger with oil.
2. Oil, air, or gas leaks may lower the oil pressure. Additionally, oil leaks may cause burning of bearings. As such, if oil, air, or gas leaks occur, check the leaking parts and solve the problem.

#### During operation

1. Insufficient oil pressure may cause abnormal wear and burning of bearings and excessive oil pressure may cause leaks.
2. Continuing to operate the engine after noises or vibrations coming from the engine may lead to serious engine damage. As such, if noises or vibrations come from the engine, slowly decrease the rpm to stop the engine and examine the cause.

#### Stopping the engine

Do not suddenly stop the engine after it was operated under high loads for a long period. If oil burns because of heat sent from the high-temperature turbine blade to the bearing part, the bearing metal and rotating shaft may burn. As such, if the engine was operated under high loads for a long period, sufficiently rotate the engine at idle before stopping it.

## 2. Operation and maintenance

---

### Break-in period of the engine

#### General information

Doosan engines are subjected to a final approval test to ensure the provision of high quality engines before being shipped to ensure the best quality possible. However, engines are not operated for a long period of time in this test. Therefore, new engines require a break-in period of during the initial 50 hours after delivery. By properly breaking-in an engine, the highest levels of engine performance can be maintained long-term.

#### Break-in period of a new engine

If the engine's bearings are not properly broken in, they may be easily damaged and the lifetime of the engine may be shortened by overloading or high-speeds. In order to prevent this, please follow the guidelines below for the initial 50 hours after delivery of new engine.

1. Fully warm up the engine until the engine temperature reaches normal operation condition, before starting operation of the engine.
2. Do not overload the engine or operate it at excessive RPM.
3. Do not operate the engine with high speed at idle.
4. Do not rapidly start up or stop the engine.
5. Operate the engine with less than 70 % of the engine load.
6. Inspection, check, and repair of engines should be managed by officially-certified technicians at certified service centers in compliance with corresponding rules.

#### Check points

check the following during the break-in period of a new engine.

1. Periodically check if the engine oil level is between the minimum and maximum limit of the oil level gauge.

---

### CAUTION

---

**If you cannot accurately check the oil level through the oil level gauge, rotate the oil level gauge to 180 degree, put it in the guide tube, and then pull it out again to check.**

---

2. If the oil indicator lamp on the apparatus is turned on or blinks, the oil pressure may be insufficient. In this case, check the oil level and replenish the oil if required. When replenishing engine oil, do not exceed the maximum on the oil level gauge. If the oil level is normal, check other related parts such as the oil pressure sensor, oil pump, or oil line.

---

### CAUTION

---

**The oil pressure may increase with high rpm and decrease with low rpm. In addition, the pressure of cold oil may be higher at a specific rpm than of warm oil. This phenomenon may occur when the engine is operating successfully.**

---

3. Check the coolant gauge on the apparatus and if the coolant circulates properly. If the coolant level in the supplementary tank is too low, the coolant gauge may be inaccurate. (may be disturbed).
4. Exchange engine oil and oil filter after the break-in period.

---

### CAUTION

---

**If engine oil and oil filter need to be replaced, use only the genuine engine oil and parts recommended by Doosan.**

---

#### Operation after Break-in

Slowly preheat the engine when starting up during cold weather or in areas with cold climate. Do not rapidly raise the rpm while the engine has not been properly preheated yet. The engine consumes additional oil until its piston ring is positioned properly and operates successfully. Please check the engine oil level frequently during the initial 50 hour break-in period.

#### Inspection after starting the engine

Check the pressure of the engine lubrication system by using the engine oil pressure gauge mounted on the apparatus while the engine is in operation. If the oil pressure is low on oil pressure gauge, immediately stop the engine. In addition, make sure that the recharge alarm indicator lamp of the alternator is turned off while the engine is operating.

1. Tightly connect the +/- terminals to prevent gaps between them. The sheath of battery connection cables should not be damaged or broken.

2. If the recharge alarm indicator lamp suddenly turns on or blinks during engine operation and the engine stops, fix the fault of the electric apparatus.
3. If color or odor of exhaust gas is unusual during operation, stop the engine, diagnose the cause and fix the fault.
4. Check the engine status through the alarm indicator lamp and gauges mounted on the apparatus during operation.

### **Engine oil pressure**

If the engine oil pressure is not consistent at idle or does not reach the reference value while the engine is operating in high speed mode, immediately stop the engine and check the oil level and leakage.

### **Coolant temperature**

Operating an engine with insufficient coolant temperature increases fuel consumption, abrasion of the cylinder liner, shortening the engine's life span.

### **Revolutions per minute (rpm)**

In the electronic control engine, the engine control unit (ECU) prevents the engine from being operated at too high rpm over the specifications to protect the engine. The memory of ECU has various functions which cannot be changed by operators, such as fuel flow control, ignition time delay, and blocking of fuel and ignition.

## 2. Operation and maintenance

---

### Operation in winter

#### Cold start

Periodically check for frozen coolant and viscosity of lubrication oil.

---

#### CAUTION

---

- **A preheater should be mounted on the engine to improve the cold start performance.**
  - **Start the engine after turning off the preheating lamp.**
  - **Do not operate the starter motor for over 10 seconds. If the engine does not start even though it is fully preheated, wait for about 30 seconds, preheat the engine again, and then start the engine.**
- 

Perform the cold start in the following order.

1. Turn the key switch to 'Preheat' and then the preheat lamp will operate for about 20 seconds.

Note) Operate the preheater if coolant is below 10 °C during cold weather. If preheating is not necessary, the preheat lamp will not switch on.

2. When the preheat lamp switches off, turn the key switch to 'Start' to start the engine.

Note) If the key is turned to 'Start', the air heater is continuously heated to provide an easy start and reduce white exhaust gas. If the coolant temperature is above 10 °C, it is not necessary to heat the air heater.

3. After starting the engine, the key switch changes to ON.

---

#### CAUTION

---

**As the ECU heats the intake air for about 180 seconds after starting the engine, the white exhaust gas is reduced quickly.**

---

#### Preventing coolant from freezing.

When only water used as coolant without mixing with anti-freeze, corrosion in the engine, degradation of cooling efficiency, and freezing of the engine in winter may occur. If the engine is not operated for a long period during cold weather or in areas with cold climate, fully discharge the coolant from the engine. Freezing of coolant leads to critical damage to the engine. Please use a mixture of coolant with antifreeze at revised ratio when replacing or replenishing the coolant. The antifreeze prevents coolant from freezing.

#### Preventing overcooling of the engine

When the engine is cooled below the normal operating temperature, thermal efficiency is lowered and fuel consumption as well as abrasion of the cylinder liner may increase. Therefore, the engine should be operated within the normal operating temperature. If the engine has been sufficiently operated, but the temperature of coolant remains below the normal operating temperature, check the water temperature controller or other parts related to the cooler.

#### Engine oil

When the viscosity of engine oil increases due to its low temperature during cold weather or in areas with cold climate, the rpm may not be stable after starting the engine. To prevent this, replace the oil with engine oil for cold weather or areas with cold climate. When replacing engine oil, Use only engine oil recommended by Doosan.

### Inspection and repair of the engine

#### Checking engine parts after prolonged operation

Wear, corrosion, or degradation of engine elements and assemblies may occur, causing lowered performance of engine parts. To maintain high engine performance, check the engine after prolonged operation to enhance the durability of the engine.

Unexpected faults may occur in some weak engine parts after normal operation of the engine, when operation time is prolonged. In this case, it is difficult to maintain high engine performance by simply repairing some parts. We recommend the entire part be replaced or repaired in order to find out the causes more accurately and maintain high engine performance.

To prevent engine failure in advance and use the engine safely for a long period, perform periodic replacements and inspections.

It is recommended to perform engine adjustments and preventive inspections during spring after the engine was exposed to winter or cold weather. This allows economic, long-term use of the engine without faults.

As the following parts affect the engine output and performance, these parts should be regularly checked and inspected.

1. Parts affecting intake and exhaust
  - Air filter
  - Intercooler
  - Turbocharger, silencer
  - EGR cooler and Valve
  - Other parts
2. Parts affecting lubrication and cooling
  - Air filter
  - Oil filter
  - Antifreeze
  - Other parts

#### Inspection and repair of turbocharger

As performance of turbocharger significantly affects the engine performance, regular inspections and repairs should be performed and inspection and maintenance regulations should be observed.

#### Intake unit

Be careful when handling the air filter in the intake unit. If oil level of the wet air filter is below the specified level, filtering performance is degraded. On the other hand, if the oil level is higher, oil may flow into the case, and it may become polluted. In regards to the dry air filter, intake resistance should be small to ensure the smooth intake of air.

#### Exhaust unit

If exhaust emission is leaked from the part connecting the exhaust tube and the turbocharger, the turbocharger efficiency is lowered, causing degraded engine output and, if serious, burning of related parts. As parts related to exhaust and turbocharger are used at high temperature, be careful not to mix the bolts and nuts with other parts when performing repair.

#### Lubrication system

Inspection and replacement of the lubrication system should be performed according to the replacement schedule of oil and oil filter. Overheated engine oil can affect not only the engine itself, but also the engine performance.

## 2. Operation and maintenance

---



# 3. Performance and specifications

Engine specifications and performance .....	19
Engine specifications .....	19
Engine power .....	29
Engine performance curve (DL06-LEE00/LEE08) .....	30
Engine performance curve (DL06-LEE01/LEE09) .....	31
Engine performance curve (DL06-LEE02/LEE10/LEE18/LEE21) .....	32
Engine performance curve (DL06-LEE03/LEE11/LEE19) .....	33
Engine performance curve (DL06-LEE04/LEE12/LEE20) .....	34
Engine performance curve (DL06-LEE05/LEE13) .....	35
Engine performance curve (DL06-LEE06/LEE14) .....	36
Engine performance curve (DL06-LEE07/LEE15/LEE22) .....	37
Engine performance curve (DL06-LEE17) .....	38
Engine performance curve (DL06-LEF00) .....	39
Engine performance curve (DL06-LEF01) .....	40
Engine performance curve (DL06-LEL00/LEL01/LEL04) .....	41
Engine performance curve (DL06-LEL05) .....	42
Engine performance curve (DL06-LEL06) .....	43
Outside drawing of the engine (DL06-LEE00/03/04/06/07/08/11/12/14/15/17/19/20/22) ...	44
Structure diagram .....	44
Left/Right sectional view .....	45
Top view.....	46
Outside drawing of the engine (DL06-LEE01/09) .....	47
Structure diagram .....	47
Left/Right sectional view .....	48
Top view.....	49
Outside drawing of the engine (DL06-LEE02/10/18) .....	50
Structure diagram .....	50
Left/Right sectional view .....	51
Top view.....	52
Outside drawing of the engine (DL06-LEE05/13/21) .....	53
Structure diagram .....	53
Left/Right sectional view .....	54
Top view.....	55
Outside drawing of the engine (DL06-LEF00/01) .....	56
Structure diagram .....	56
Left/Right sectional view .....	57
Top view.....	58

Outside drawing of the engine (DL06-LEL00/01) .....	59
Structure diagram .....	59
Left/Right sectional view .....	60
Top view.....	61
Outside drawing of the engine (DL06-LEL04/05/06) .....	62
Structure diagram .....	62
Left/Right sectional view .....	63
Top view.....	64
Engine identification number .....	65
Engine code and manufacturing number .....	65
Engine number engraving.....	65

### 3. Performance and specifications

#### Engine specifications and performance

#### Engine specifications

Items	DL06P									Remarks	
	LEE00	LEE01	LEE02	LEE03	LEE04	LEE05	LEE06	LEE07			
General information											
Engine type	4-stroke, inline, water-cooled, turbocharged and air-cooled										
Combustion chamber type	Direct injection										
Cylinder liner type	Dry liner										
Timing gear system	Gear driven type										
No. of piston rings	2 compression rings and 1 oil ring										
No. of cylinders	6										
Cylinder I.D. (mm)	100										
Cylinder stroke (mm)	125										
Total displacement (cc)	5,890										
Compression ratio	17.3:1										
Compression pressure (bar)	29									at 200 rpm	
Engine dimensions	Length (mm)	1,264	1,264	1,264	1,264	1,264	-	1,264	-		
	Width (mm)	848	848	848	848	848	-	848	-		
	Height (mm)	1,174	1,124	1,124	1,174	1,124	-	1,174	-		
Engine weight (kg)	645	644	644	645	644	-	645	-			
Rotating direction	Counterclockwise									When seeing from flywheel side	
Ignition order	1-5-3-6-2-4										
Cooling system											
Cooling method	Forced water-cooled										
Coolant capacity (L)	13									Engine internal area	
Coolant pump type	Centrifugal (impeller type)										
Coolant temperature controller	Type	Wax pellet type									
	Opening temperature (°C)	83									
	Fully open temperature (°C)	95									
Coolant temperature indicator	Coolant temp. sensor mounted										
Cooling fan type (mm)	700	650	700			650	650				
Lubrication system											

### 3. Performance and specifications

Items		DL06P							Remarks
		LEE00	LEE01	LEE02	LEE03	LEE04	LEE05	LEE06	
Lubrication method		Forced lubrication							
Oil pressure	Idle (bar)	Above 1.0 bar							
	Rated (bar)	Above 3.0 bar							
Oil specification	Oil grade	API CJ-4 or ACEA-E9 higher							
	SAE viscosity	10W40							
Oil capacity	Total (L)	29				24			
	Maximum (L)	27				22			
	Minimum (L)	15				16			
Allowable oil pan inclination angle (°)		35 / 35 / 35 / 35							Front/Rear/Left/Right
Oil pump type		Gear type							
Oil cooler type		Water-cooled layered plate							
Oil strainer type		Full flow (cartridge)							
Oil separator type		Impact (CCV)							
Hydraulic pressure indicator		Oil pressure sensor							
Fuel system									
Fuel high-pressure pump type		BOSCH CP3.3NH high-pressure pump							
Engine control		ECU (Electronic Control Unit)							
Nozzle opening pressure (bar)		1,800							Operating pressure
Injector nozzle type		Multi-hole type							
Fuel filter type		Full flow (cartridge)							
Intake/exhaust system									
Turbocharger		WGT (Waste Gate Turbocharger)							
Cylinder block/head									
Valves		Overhead valve							
Valve clearance	Intake (mm)	0.3 ±0.05							Cold
	Exhaust (mm)	0.4 ±0.05							Cold
Electric system									
Start motor	Type	Reduction type							
	Capacity (V-KW)	24-6							
Preheat system (V-kW)		24-2.1							Air heater

### 3. Performance and specifications

Items	DL06P									Remarks	
	LEE08	LEE09	LEE10	LEE11	LEE12	LEE13	LEE14	LEE15			
General information											
Engine type	4-stroke, inline, water-cooled, turbocharged and air-cooled										
Combustion chamber type	Direct injection										
Cylinder liner type	Dry liner										
Timing gear system	Gear driven type										
No. of piston rings	2 compression rings and 1 oil ring										
No. of cylinders	6										
Cylinder I.D. (mm)	100										
Cylinder stroke (mm)	125										
Total displacement (cc)	5,890										
Compression ratio	17.3:1										
Compression pressure (bar)	29									at 200 rpm	
Engine dimensions	Length (mm)	1,264	1,264	1,264	1,264	1,264	-	1,264	-		
	Width (mm)	848	848	848	848	848	-	848	-		
	Height (mm)	1,174	1,124	1,124	1,174	1,124	-	1,174	-		
Engine weight (kg)	645	644	644	645	644	-	645	-			
Rotating direction	Counterclockwise									When seeing from fly-wheel side	
Ignition order	1-5-3-6-2-4										
Cooling system											
Cooling method	Forced water-cooled										
Coolant capacity (L)	13									Engine internal area	
Coolant pump type	Centrifugal (impeller type)										
Coolant temperature controller	Type	Wax pellet type									
	Opening temperature (°C)	83									
	Fully open temperature (°C)	95									
Coolant temperature indicator	Coolant temp. sensor mounted										
Cooling fan type (mm)	700	650	700			650	650				
Lubrication system											
Lubrication method	Forced lubrication										

### 3. Performance and specifications

Items		DL06P							Remarks
		LEE08	LEE09	LEE10	LEE11	LEE12	LEE13	LEE14	
Oil pressure	Idle (bar)	Above 1.0 bar							
	Rated (bar)	Above 3.0 bar							
Oil specification	Oil grade	API CJ-4 or ACEA-E9 higher							
	SAE viscosity	10W40							
Oil capacity	Total (L)	29				24			
	Maximum (L)	27				22			
	Minimum (L)	15				16			
Allowable oil pan inclination angle (°)		35 / 35 / 35 / 35							Front/Rear/Left/Right
Oil pump type		Gear type							
Oil cooler type		Water-cooled layered plate							
Oil strainer type		Full flow (cartridge)							
Oil separator type		Impact (CCV)							
Hydraulic pressure indicator		Oil pressure sensor							
Fuel system									
Fuel high-pressure pump type		BOSCH CP3.3NH high-pressure pump							
Engine control		ECU (Electronic Control Unit)							
Nozzle opening pressure (bar)		1,800							Operating pressure
Injector nozzle type		Multi-hole type							
Fuel filter type		Full flow (cartridge)							
Intake/exhaust system									
Turbocharger		WGT (Waste Gate Turbocharger)							
Cylinder block/head									
Valves		Overhead valve							
Valve clearance	Intake (mm)	0.3 ±0.05							Cold
	Exhaust (mm)	0.4 ±0.05							Cold
Electric system									
Start motor	Type	Reduction type							
	Capacity (V-KW)	24-6							
Preheat system (V-kW)		24-2.1							Air heater

### 3. Performance and specifications

Items	DL06P							Remarks	
	LEE17	LEE18	LEE19	LEE20	LEE21	LEE22			
General information									
Engine type	4-stroke, inline, water-cooled, turbocharged and air-cooled								
Combustion chamber type	Direct injection								
Cylinder liner type	Dry liner								
Timing gear system	Gear driven type								
No. of piston rings	2 compression rings and 1 oil ring								
No. of cylinders	6								
Cylinder I.D. (mm)	100								
Cylinder stroke (mm)	125								
Total displacement (cc)	5,890								
Compression ratio	17.3:1								
Compression pressure (bar)	25							at 200 rpm	
Engine dimensions	Length (mm)	1,264	1,264	1,264	1,264	1,264	1,264		
	Width (mm)	848	848	848	848	848	848		
	Height (mm)	1,174	1,124	1,174	1,124	1,124	1,174		
Engine weight (kg)	645	644	645	644	644	645			
Rotating direction	Counterclockwise							When seeing from flywheel side	
Ignition order	1-5-3-6-2-4								
Cooling system									
Cooling method	Radiator								
Coolant capacity (L)	17							Engine internal area	
Coolant pump type	Centrifugal (pulley type)								
Coolant temperature controller	Type	Unit + Housing (wax-pellet)							
	Opening temperature (°C)	83							
	Fully open temperature (°C)	95							
Coolant temperature indicator	Coolant temp. sensor mounted								
Cooling fan type (mm)	700	700	700	700	685	650			
Lubrication system									
Lubrication method	Forced lubrication								
Oil pressure	Idle (bar)	1.0 bar							
	Maximum (bar)	3.0 bar							

### 3. Performance and specifications

Items		DL06P						Remarks
		LEE17	LEE18	LEE19	LEE20	LEE21	LEE22	
Oil specification	Oil grade	API CJ-4						
	SAE viscosity	10W40						
Oil capacity	Total (L)	29				24		
	Maximum (L)	27				22		
	Minimum (L)	15				16		
Allowable oil pan inclination angle (°)		35 / 35 / 35 / 35						Front/Rear/Left/Right
Oil pump type		External spur gear type						
Oil cooler type		Water-cooled layered plate						
Oil strainer type		Full flow (cartridge)						
Oil separator type		Impact (CCV)						
Hydraulic pressure indicator		Oil pressure sensor						
Fuel system								
Fuel high-pressure pump type		Common rail system						
Engine control		ECU (BOSCH, EDC17CV41)						
Nozzle opening pressure (bar)		1,800						Operating pressure
Injector nozzle type		Multi-hole type						
Fuel filter type		Full flow (cartridge)						
Intake/exhaust system								
Turbocharger		WGT (Waste Gate Turbocharger)						
Cylinder block/head								
Valves		Overhead valve						
Valve clearance	Intake (mm)	0.3 ±0.05						Cold
	Exhaust (mm)	0.4 ±0.05						Cold
Electric system								
Start motor	Type	Reduction type						
	Capacity (V-KW)	24-6						
Preheat system (V-kW)		24-2.1						Air heater



### 3. Performance and specifications

Items	DL06P				Remarks
	LEF00	LEF01	LEL00	LEL01	
General information					
Engine type	4-stroke, inline, water-cooled, turbocharged and air-cooled				
Combustion chamber type	Direct injection				
Cylinder liner type	Dry liner				
Timing gear system	Gear driven type				
No. of piston rings	2 compression rings and 1 oil ring				
No. of cylinders	6				
Cylinder I.D. (mm)	100				
Cylinder stroke (mm)	125				
Total displacement (cc)	5,890				
Compression ratio	17.3:1				
Compression pressure (bar)	29				at 200 rpm
Engine dimensions	Length (mm)	-	-	-	-
	Width (mm)	-	-	-	-
	Height (mm)	-	-	-	-
Engine weight (kg)	-	-	-	-	
Rotating direction	Counterclockwise				When seeing from flywheel side
Ignition order	1-5-3-6-2-4				
Cooling system					
Cooling method	Forced water-cooled				
Coolant capacity (L)	13				Engine internal area
Coolant pump type	Centrifugal (impeller type)				
Coolant temperature controller	Type	Wax pellet type			
	Opening temperature (°C)	83			
	Fully open temperature (°C)	95			
Coolant temperature indicator	Coolant temp. sensor mounted				
Cooling fan type (mm)	-	-	700	650	
Lubrication system					
Lubrication method	Forced lubrication				

### 3. Performance and specifications

Items		DL06P				Remarks
		LEF00	LEF01	LEL00	LEL01	
Oil pressure	Idle (bar)	Above 1.0 bar				
	Rated (bar)	Above 3.0 bar				
Oil specification	Oil grade	API CJ-4 or ACEA-E9 higher				
	SAE viscosity	10W40				
Oil capacity	Total (L)	29				
	Maximum (L)	27				
	Minimum (L)	15		20		
Allowable oil pan inclination angle (°)		35 / 35 / 35 / 35				Front/Rear/Left/Right
Oil pump type		Gear type				
Oil cooler type		Water-cooled layered plate				
Oil strainer type		Full flow (cartridge)				
Oil separator type		Impact (CCV)				
Hydraulic pressure indicator		Oil pressure sensor				
Fuel system						
Fuel high-pressure pump type		BOSCH CP3.3NH high-pressure pump				
Engine control		ECU (Electronic Control Unit)				
Nozzle opening pressure (bar)		1,800				Operating pressure
Injector nozzle type		Multi-hole type				
Fuel filter type		Full flow (cartridge)				
Intake/exhaust system						
Turbocharger		WGT (Waste Gate Turbocharger)				
Cylinder block/head						
Valves		Overhead valve				
Valve clearance	Intake (mm)	0.3 ±0.05				Cold
	Exhaust (mm)	0.4 ±0.05				Cold
Electric system						
Start motor	Type	Reduction type				
	Capacity (V-KW)	24-6				
Preheat system (V-kW)		24-2.1				Air heater

### 3. Performance and specifications

Items	DL06P			Remarks	
	LEL04	LEL05	LEL06		
General information					
Engine type	4-stroke, inline, water-cooled, turbocharged and air-cooled				
Combustion chamber type	Direct injection				
Cylinder liner type	Dry liner				
Timing gear system	Gear driven type				
No. of piston rings	2 compression rings and 1 oil ring				
No. of cylinders	6				
Cylinder I.D. (mm)	100				
Cylinder stroke (mm)	125				
Total displacement (cc)	5,890				
Compression ratio	17.3:1				
Compression pressure (bar)	25			at 200 rpm	
Engine dimensions	Length (mm)	1,182	1,182	1,182	
	Width (mm)	825	825	825	
	Height (mm)	962	962	962	
Engine weight (kg)	773	773	773		
Rotating direction	Counterclockwise			When seeing from flywheel side	
Ignition order	1-5-3-6-2-4				
Cooling system					
Cooling method	Radiator				
Coolant capacity (L)	17			Engine internal area	
Coolant pump type	Centrifugal (pulley type)				
Coolant temperature controller	Type	Unit + Housing (wax-pellet)			
	Opening temperature (°C)	83			
	Fully open temperature (°C)	95			
Coolant temperature indicator	Coolant temp. sensor mounted				
Cooling fan type (mm)	-	-	-		
Lubrication system					
Lubrication method	Forced lubrication				

### 3. Performance and specifications

Items		DL06P			Remarks
		LEL04	LEL05	LEL06	
Oil pressure	Idle (bar)	1.0 bar			
	Rated (bar)	3.0 bar			
Oil specification	Oil grade	API CJ-4			
	SAE viscosity	10W40			
Oil capacity	Total (L)	26.5			
	Maximum (L)	24.5			
	Minimum (L)	17.5			
Allowable oil pan inclination angle (°)		30 / 30 / 30 / 30			Front/Rear/Left/Right
Oil pump type		External spur gear type			
Oil cooler type		Water-cooled layered plate			
Oil strainer type		Full flow (cartridge)			
Oil separator type		Impact (CCV)			
Hydraulic pressure indicator		Oil pressure sensor			
Fuel system					
Fuel high-pressure pump type		Common rail system			
Engine control		ECU (BOSCH, EDC17CV41)			
Nozzle opening pressure (bar)		1,800			Operating pressure
Injector nozzle type		Multi-hole type			
Fuel filter type		Full flow (cartridge)			
Intake/exhaust system					
Turbocharger		WGT (Waste Gate Turbocharger)			
Cylinder block/head					
Valves		Overhead valve			
Valve clearance	Intake (mm)	0.3 ±0.05			Cold
	Exhaust (mm)	0.4 ±0.05			Cold
Electric system					
Start motor	Type	Reduction type			
	Capacity (V-KW)	24-6			
Preheat system (V-kW)		24-2.1			Air heater

### 3. Performance and specifications

#### Engine power

Engine model		Performance				Remarks
Model	Code (Suffix)	Power (PS/rpm)	Torque (kg·m/rpm)	Low idle speed (rpm)	High idle speed (rpm)	
DL06P	LEE00	169/1,800	77/1,400	800 ±10	1,900 ±25	
	LEE01	154.4/2,000	66/1,400	800 ±10	2,100 ±25	
	LEE02	192.2/1,900	82/1,400	800 ±10	2,000 ±25	
	LEE03	176.4/1,900	77/1,400	800 ±10	2,000 ±25	
	LEE04	192.2/1,900	82/1,400	800 ±10	2,000 ±25	
	LEE05	192.2/1,900	82/1,400	800 ±10	2,000 ±25	
	LEE06	139.4/1,700	61/1,400	800 ±10	1,800 ±25	
	LEE07	139.4/2,000	60/1,400	800 ±10	2,100 ±25	
	LEE08	169/1,800	77/1,400	800 ±10	1,900 ±25	
	LEE09	154.4/2,000	66/1,400	800 ±10	2,100 ±25	
	LEE10	192.2/1,900	82/1,400	800 ±10	2,000 ±25	
	LEE11	176.4/1,900	77/1,400	800 ±10	2,000 ±25	
	LEE12	192.2/1,900	82/1,400	800 ±10	2,000 ±25	
	LEE13	192.2/1,900	82/1,400	800 ±10	2,000 ±25	
	LEE14	139.4/1,700	61/1,400	800 ±10	1,800 ±25	
	LEE15	139.4/2,000	60/1,400	800 ±10	2,100 ±25	
	LEE17	176.0/1,800	82/1,400	800 ±10	1,900 ±25	
	LEE18	192.0/1,900	82/1,400	800 ±10	2,000 ±25	
	LEE19	176.0/1,900	77/1,400	800 ±10	2,000 ±25	
	LEE20	192.0/1,900	82/1,400	800 ±10	2,000 ±25	
	LEE21	192.0/1,900	82/1,400	800 ±10	2,000 ±25	
	LEE22	139.0/2,000	60/1,400	800 ±10	2,100 ±25	
	LEF00	190.0/2,100	80/1,400	850 ±10	2,400 ±25	
	LEF01	175.0/2,100	75/1,400	850 ±10	2,400 ±25	
	LEL00	173.9/2,100	82/1,400	800 ±10	2,300 ±25	
	LEL01	173.9/2,100	82/1,400	800 ±10	2,300 ±25	
LEL04	174.0/2,100	82/1,400	800 ±10	2,300 ±25		
LEL05	161.0/2,100	71/1,400	800 ±10	2,300 ±25		
LEL06	192.0/2,000	92/1,400	800 ±10	2,300 ±25		

### 3. Performance and specifications

Engine performance curve (DL06-LEE00/LEE08)

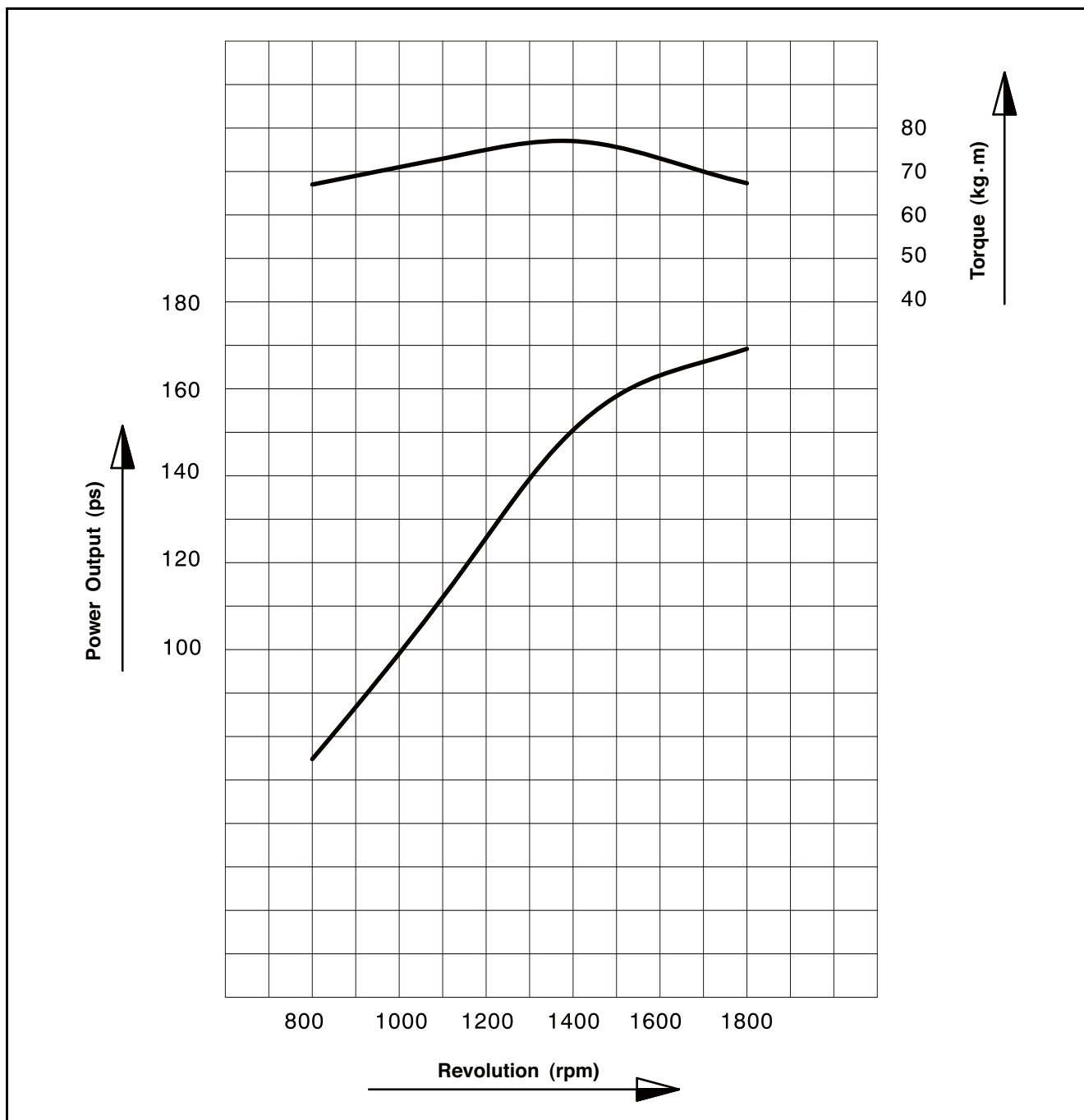

EK00326A

Standard performance	KS-R1004
Engine power (rated)	169 PS / 1,800 rpm
Torque (max.)	77.0 kg·m / 1,400 rpm

### 3. Performance and specifications

Engine performance curve (DL06-LEE01/LEE09)

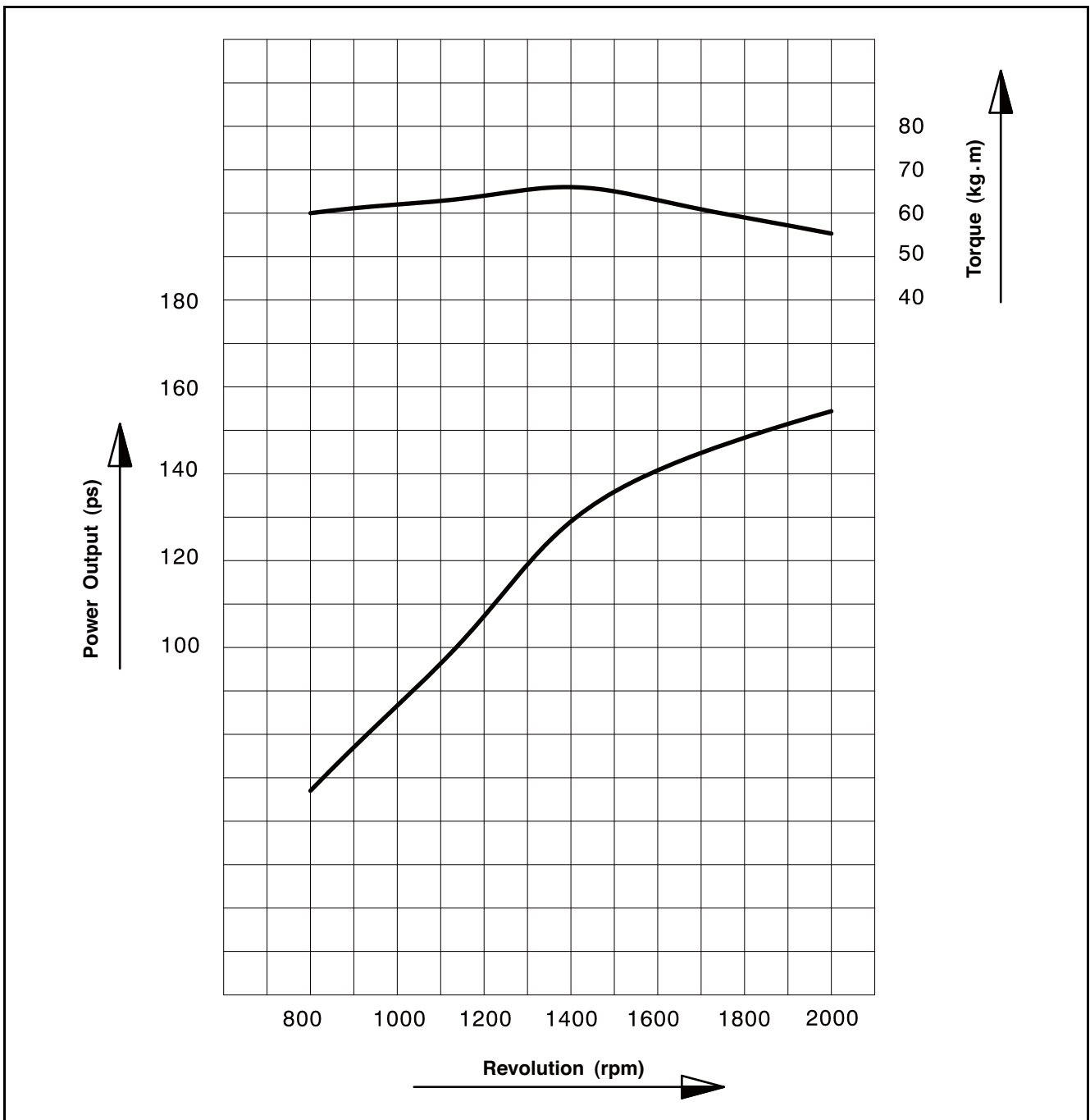

EK00327A

Standard performance	KS-R1004
Engine power (rated)	154.4 PS / 2,000 rpm
Torque (max.)	66.0 kg·m / 1,400 rpm

### 3. Performance and specifications

Engine performance curve (DL06-LEE02/LEE10/LEE18/LEE21)

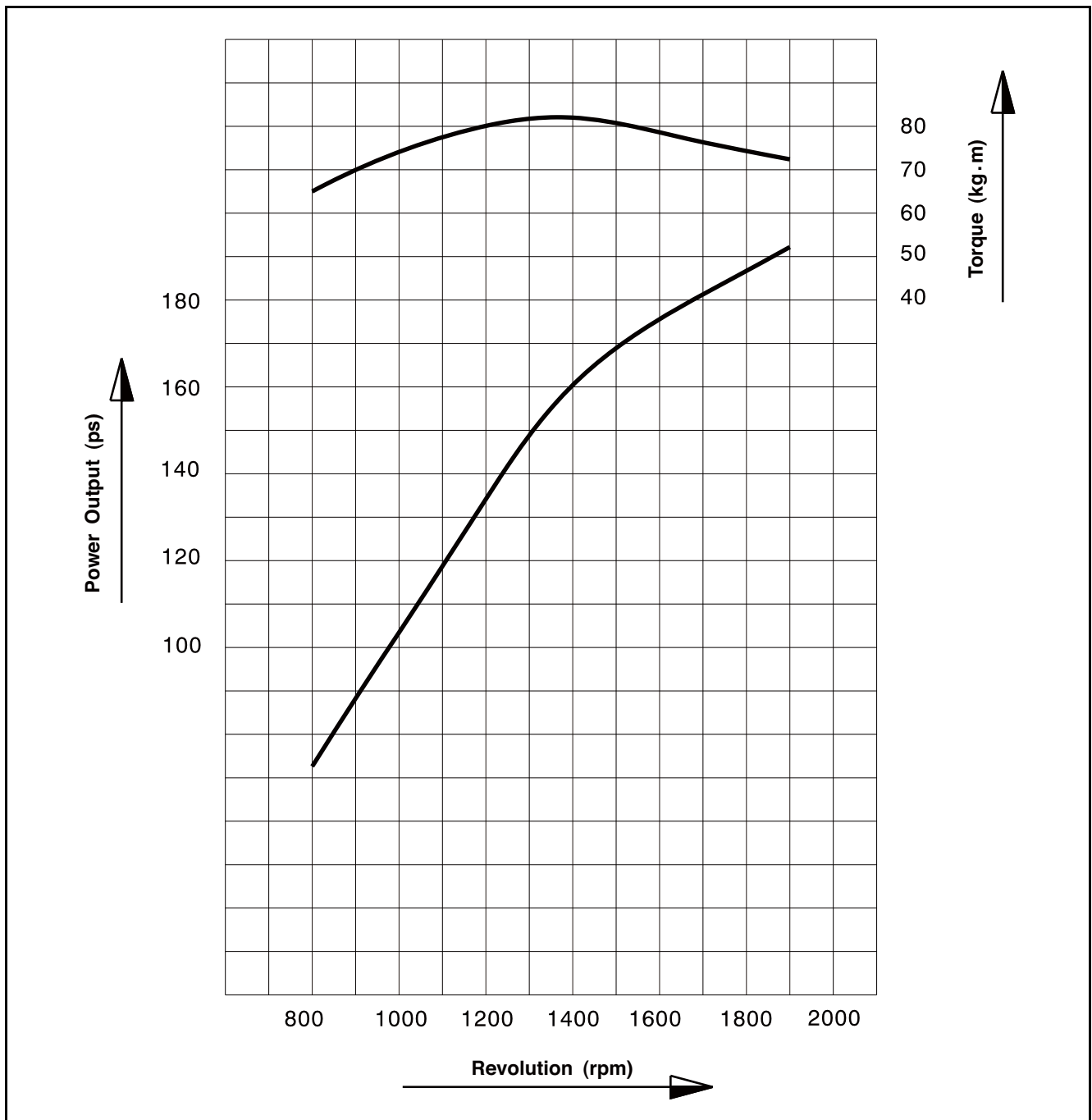

EK00328A

Standard performance	KS-R1004
Engine power (rated)	192.2 PS / 1,900 rpm
Torque (max.)	82.0 kg·m / 1,400 rpm



### 3. Performance and specifications

Engine performance curve (DL06-LEE03/LEE11/LEE19)

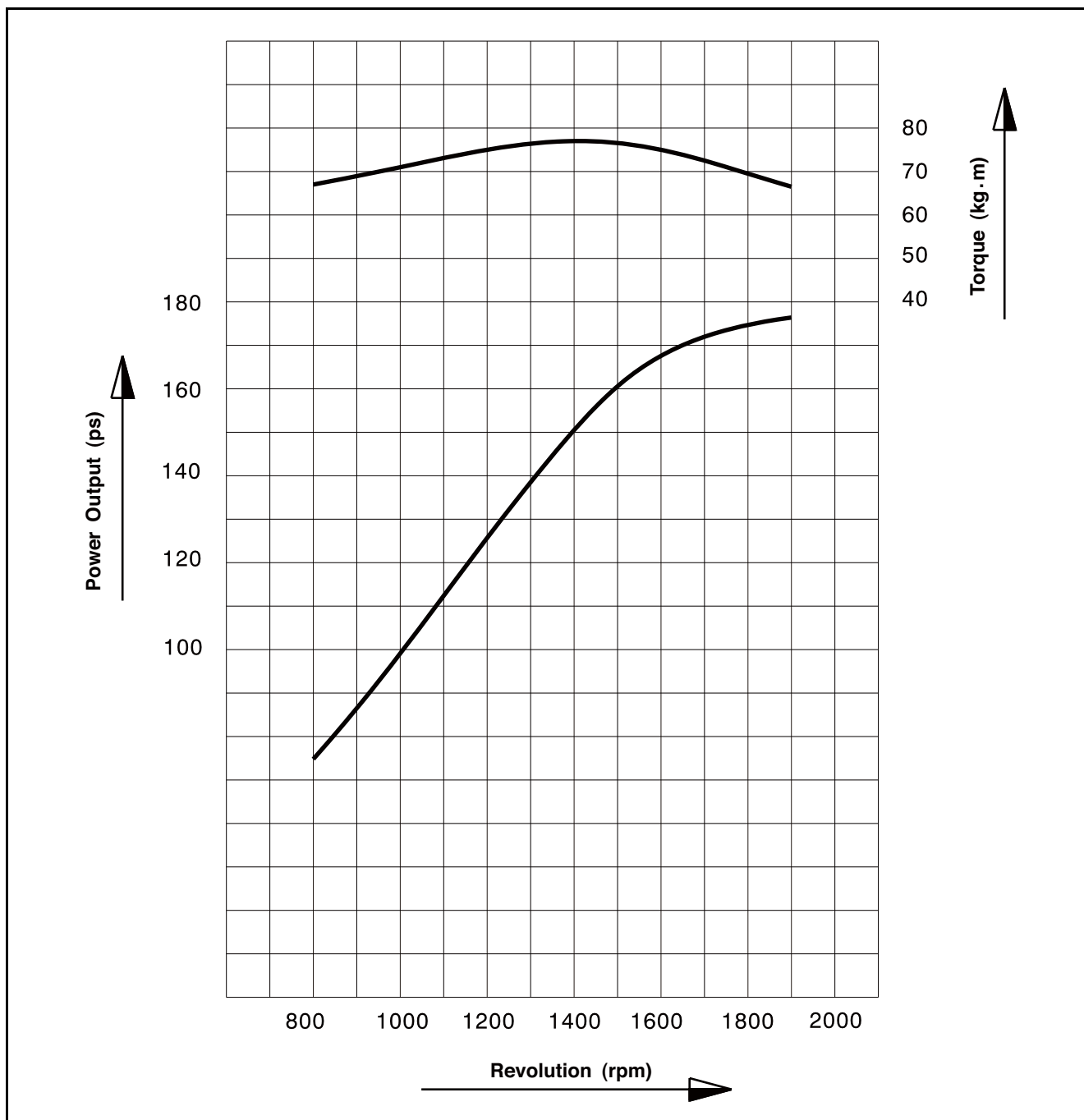

EK00329A

Standard performance	KS-R1004
Engine power (rated)	176.4 PS / 1,900 rpm
Torque (max.)	77.0 kg·m / 1,400 rpm

### 3. Performance and specifications

Engine performance curve (DL06-LEE04/LEE12/LEE20)

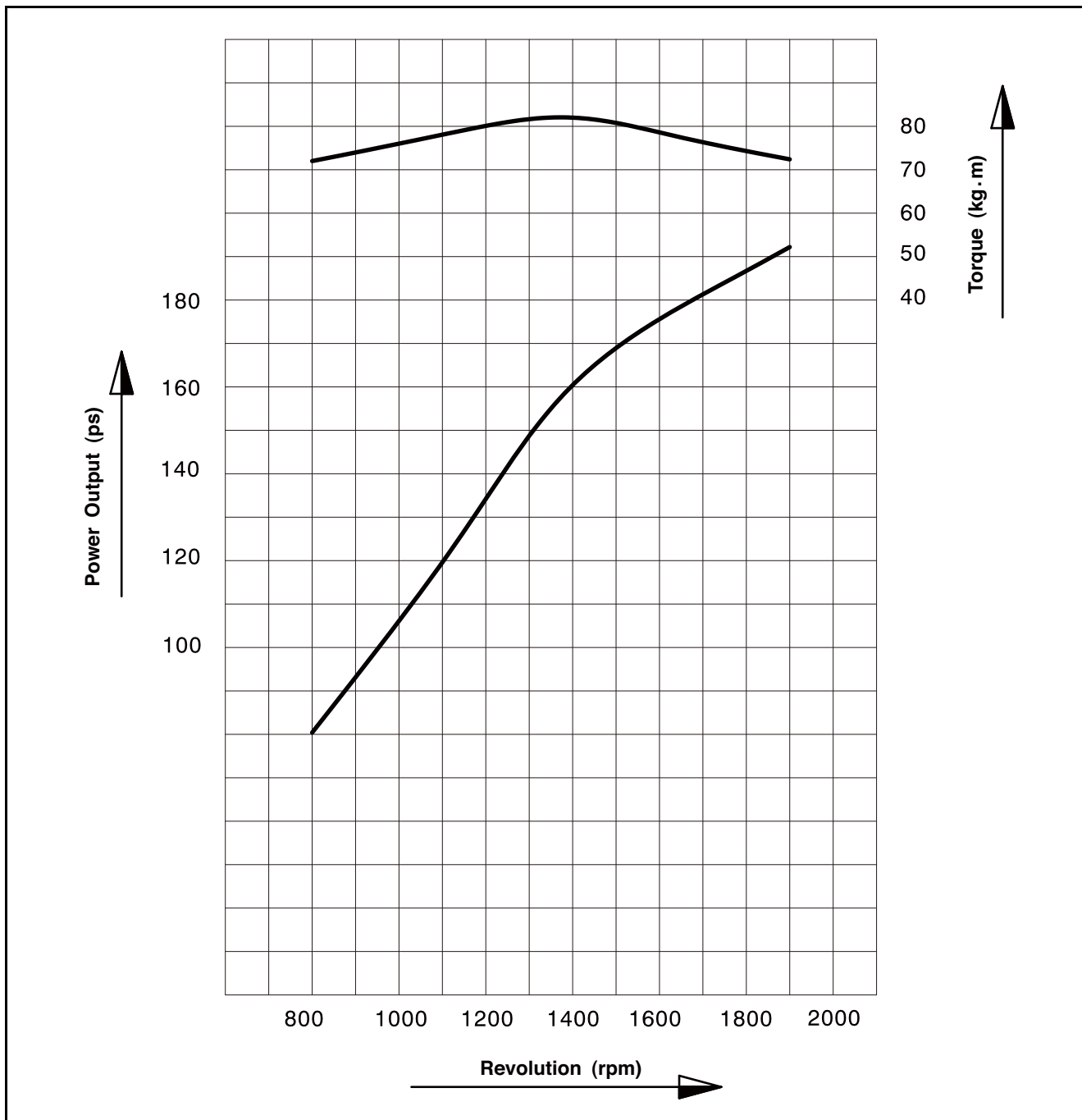

EK00330A

Standard performance	KS-R1004
Engine power (rated)	192.2 PS / 1,900 rpm
Torque (max.)	82.0 kg·m / 1,400 rpm

### 3. Performance and specifications

Engine performance curve (DL06-LEE05/LEE13)

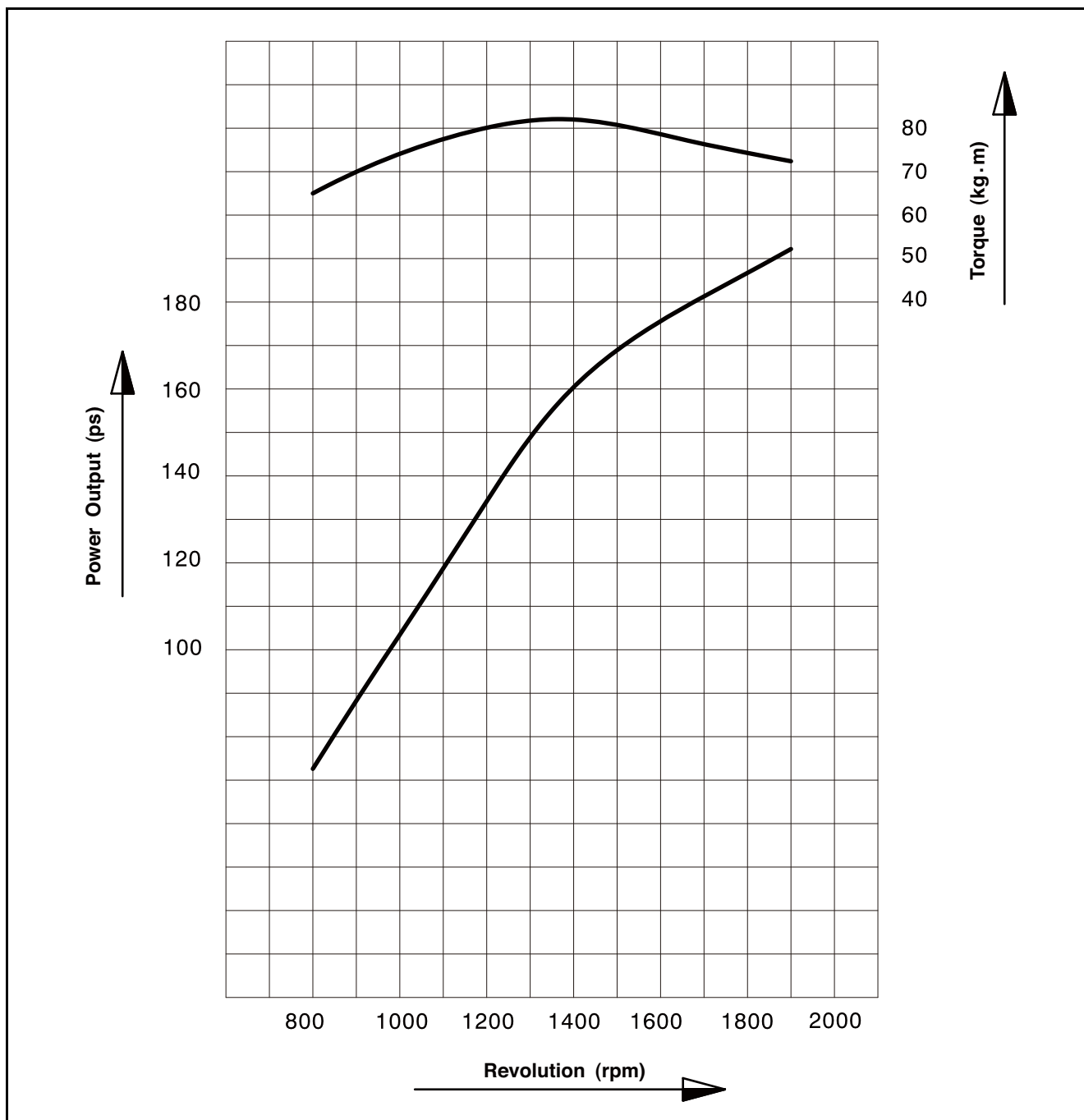

EK00331A

Standard performance	KS-R1004
Engine power (rated)	192.2 PS / 1,900 rpm
Torque (max.)	82.0 kg·m / 1,400 rpm

### 3. Performance and specifications

Engine performance curve (DL06-LEE06/LEE14)

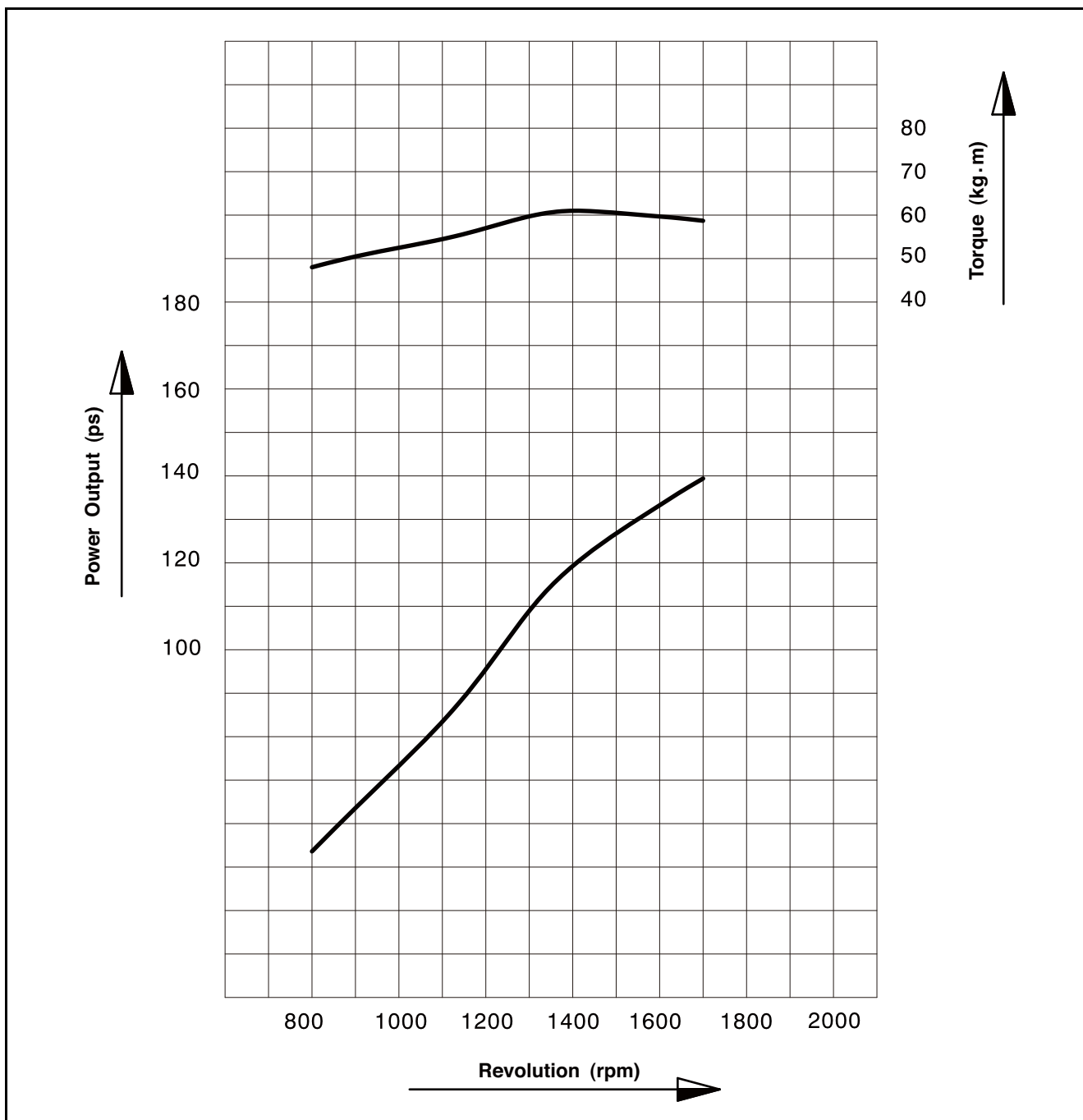

EK00332A

Standard performance	KS-R1004
Engine power (rated)	139.4 PS / 1,700 rpm
Torque (max.)	61.0 kg·m / 1,400 rpm

### 3. Performance and specifications

Engine performance curve (DL06-LEE07/LEE15/LEE22)

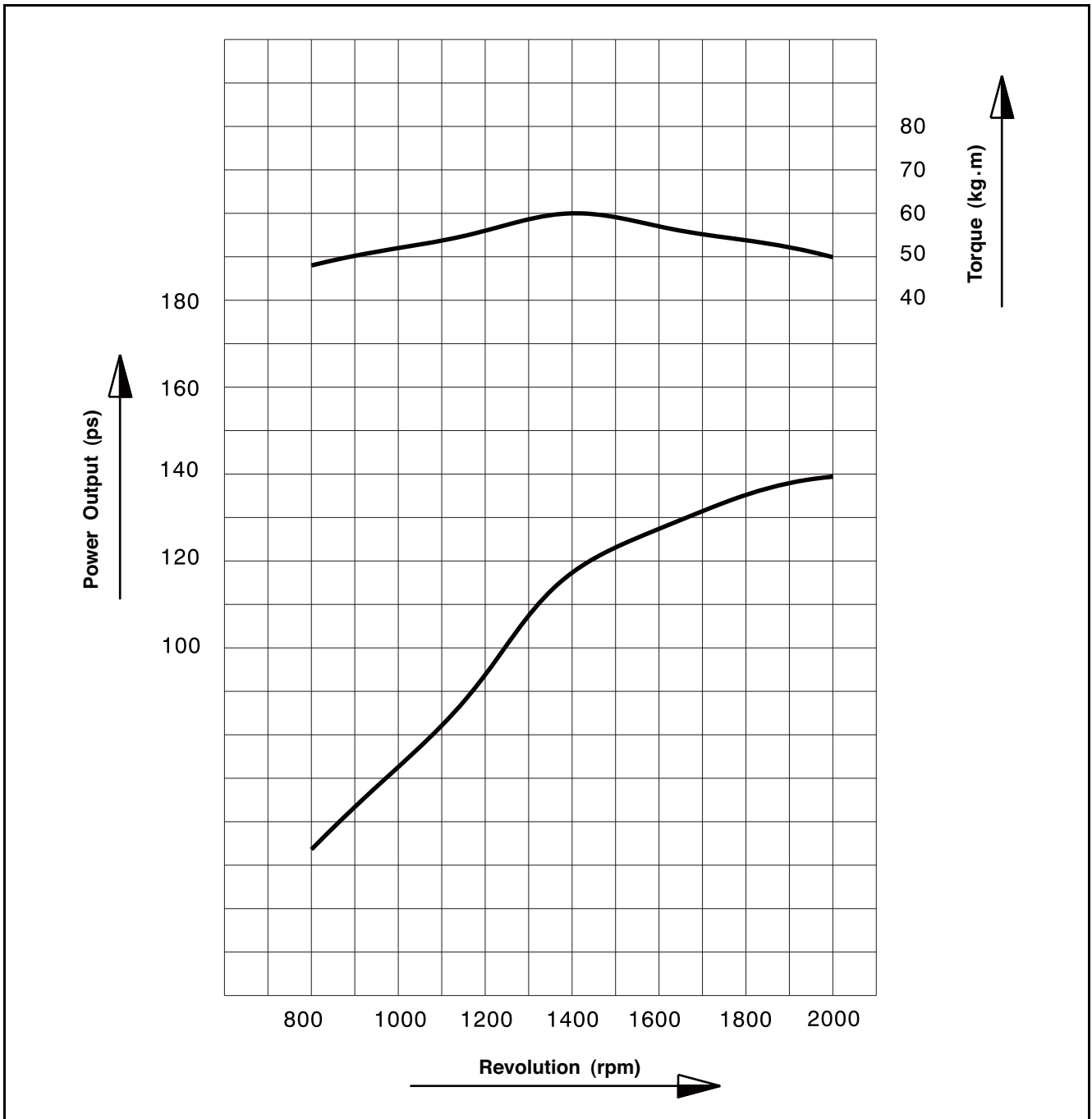

EK00333A

Standard performance	KS-R1004
Engine power (rated)	139.4 PS / 2,000 rpm
Torque (max.)	60.0 kg-m / 1,400 rpm

### 3. Performance and specifications

Engine performance curve (DL06-LEE17)

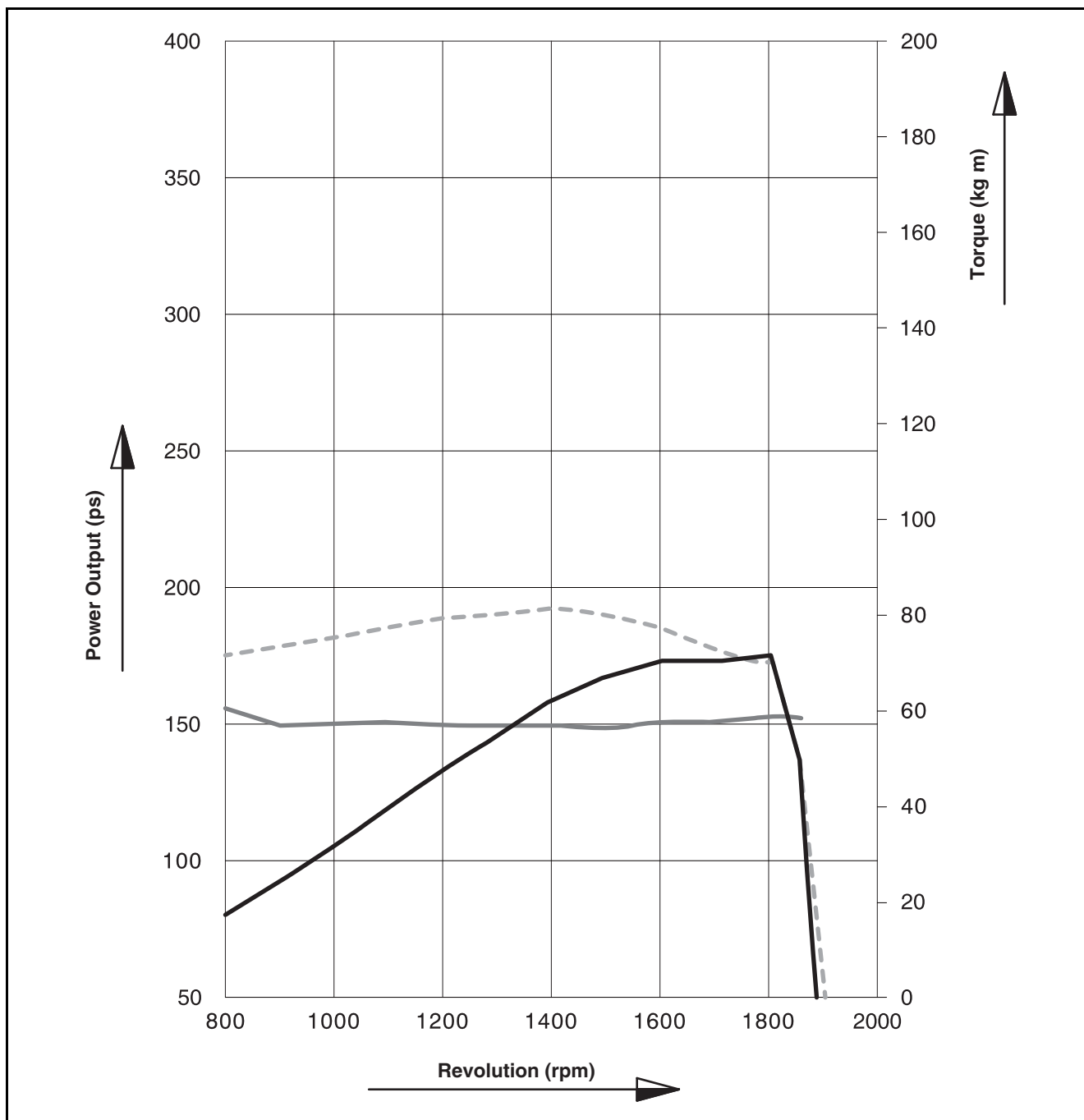

EDL06200005

Standard performance	KS-R0071
Engine power (rated)	176.0 PS / 1,800 rpm
Torque (max.)	82.1 kg-m / 1,400 rpm

### 3. Performance and specifications

Engine performance curve (DL06-LEF00)

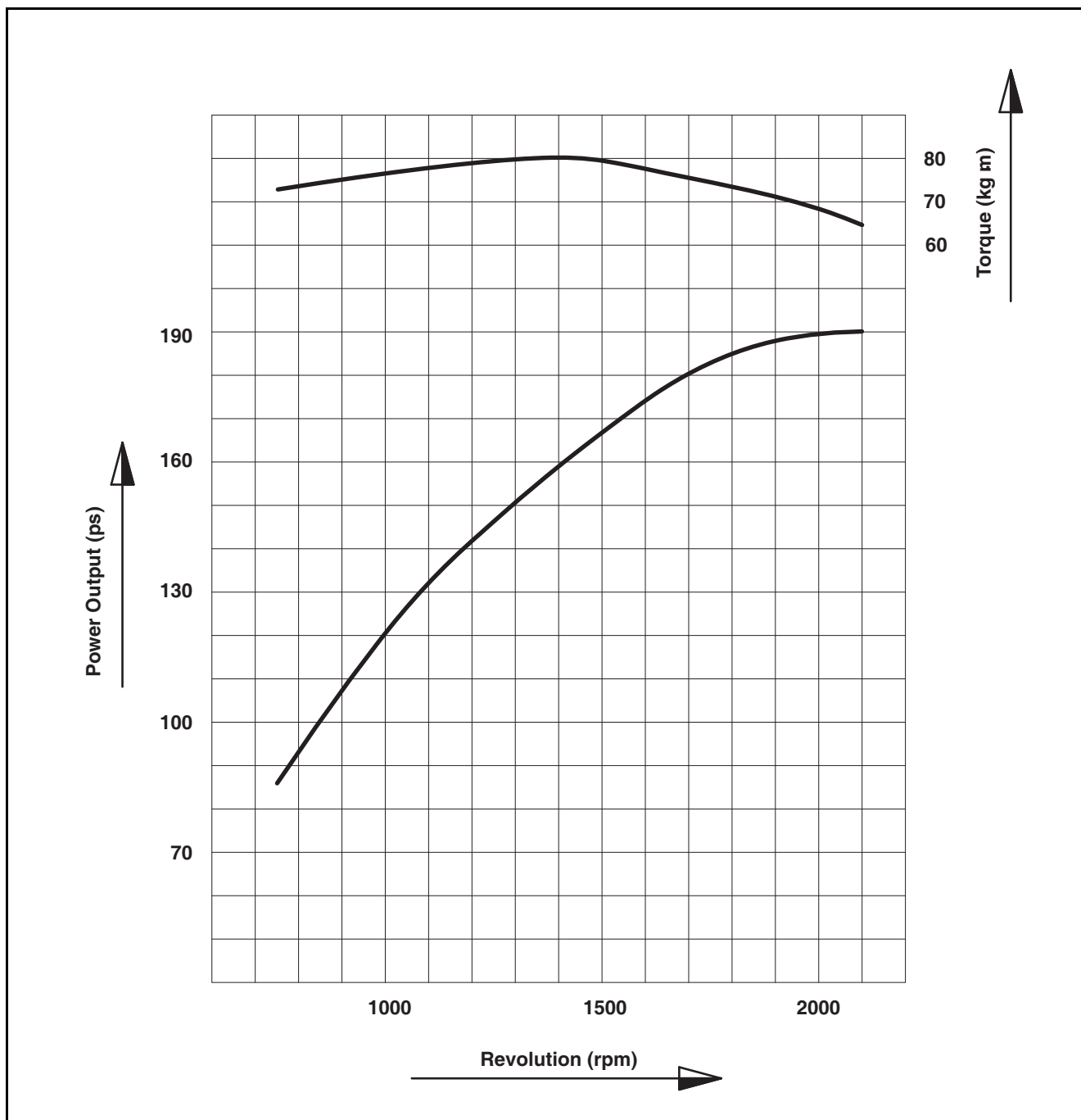

EK00333B

Standard performance	KS-B6537
Engine power (rated)	190.0 PS / 2,100 rpm
Torque (max.)	80.0 kg-m / 1,400 rpm

### 3. Performance and specifications

Engine performance curve (DL06-LEF01)

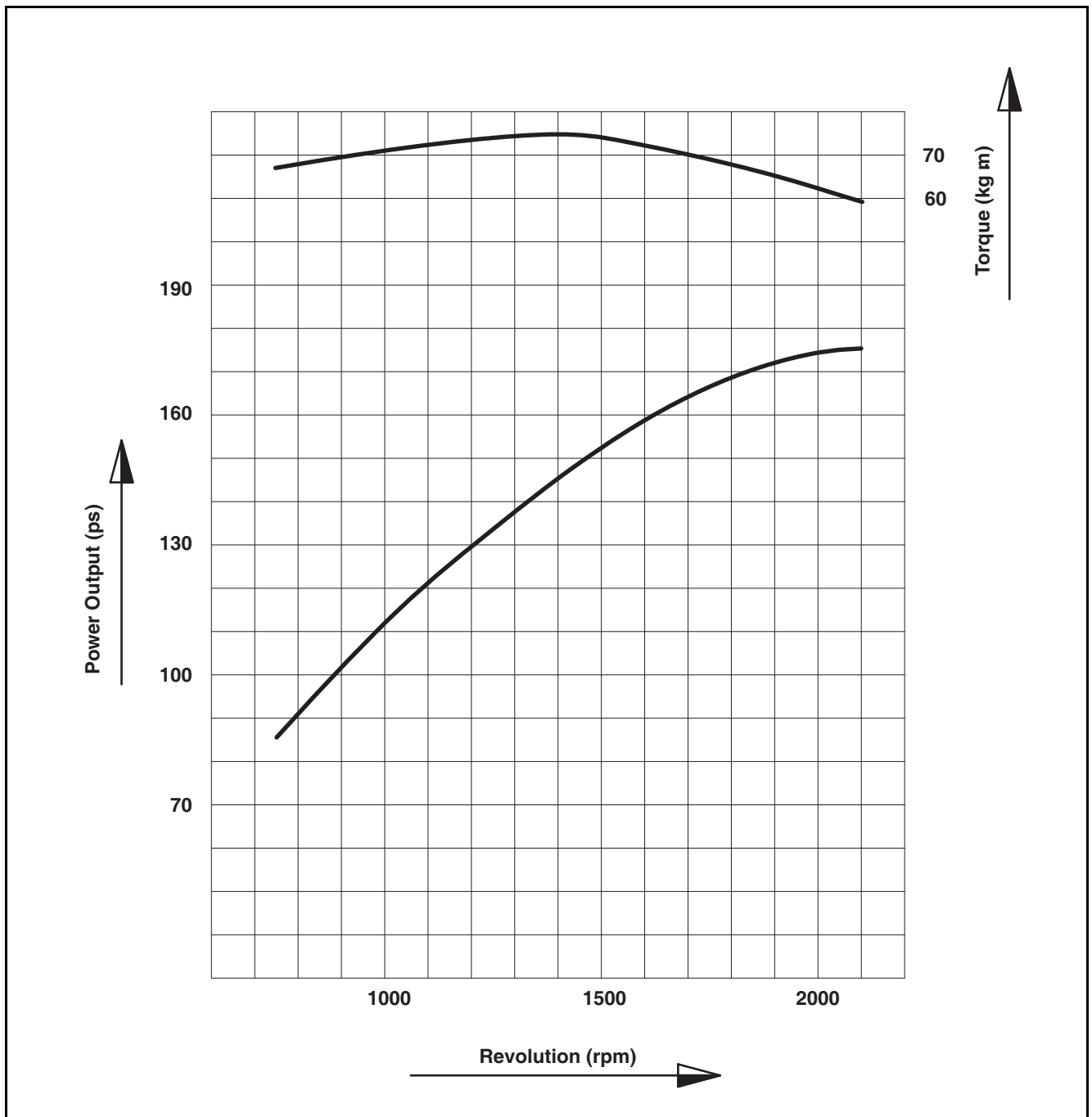

EK00333C

Standard performance	KS-B6537
Engine power (rated)	175.0 PS / 2,100 rpm
Torque (max.)	75.0 kg·m / 1,400 rpm



### 3. Performance and specifications

Engine performance curve (DL06-LEL00/LEL01/LEL04)

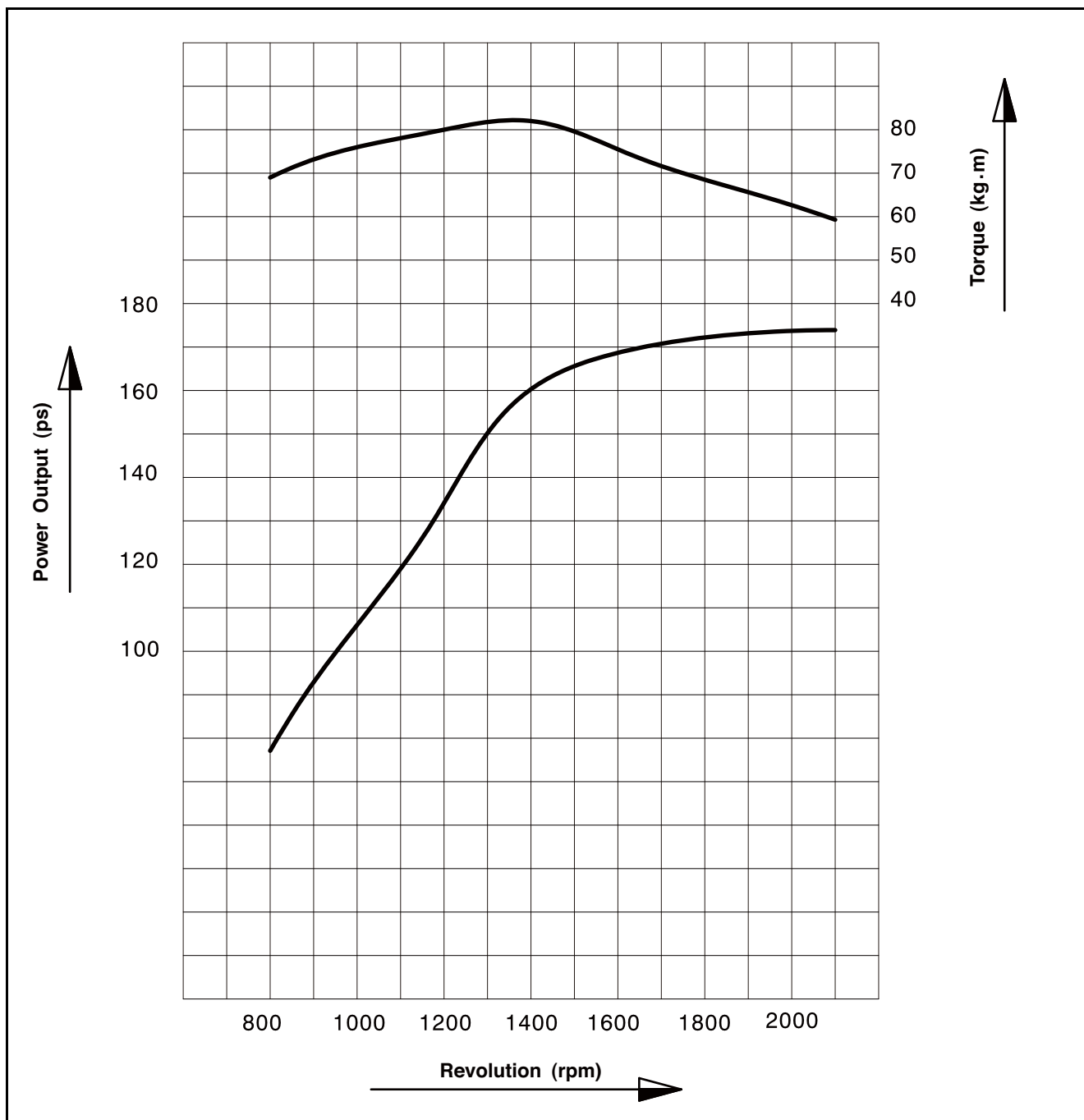

EK00334A

Standard performance	KS-R1004
Engine power (rated)	173.9 PS / 2,100 rpm
Torque (max.)	82.0 kg.m / 1,400 rpm

### 3. Performance and specifications

Engine performance curve (DL06-LEL05)

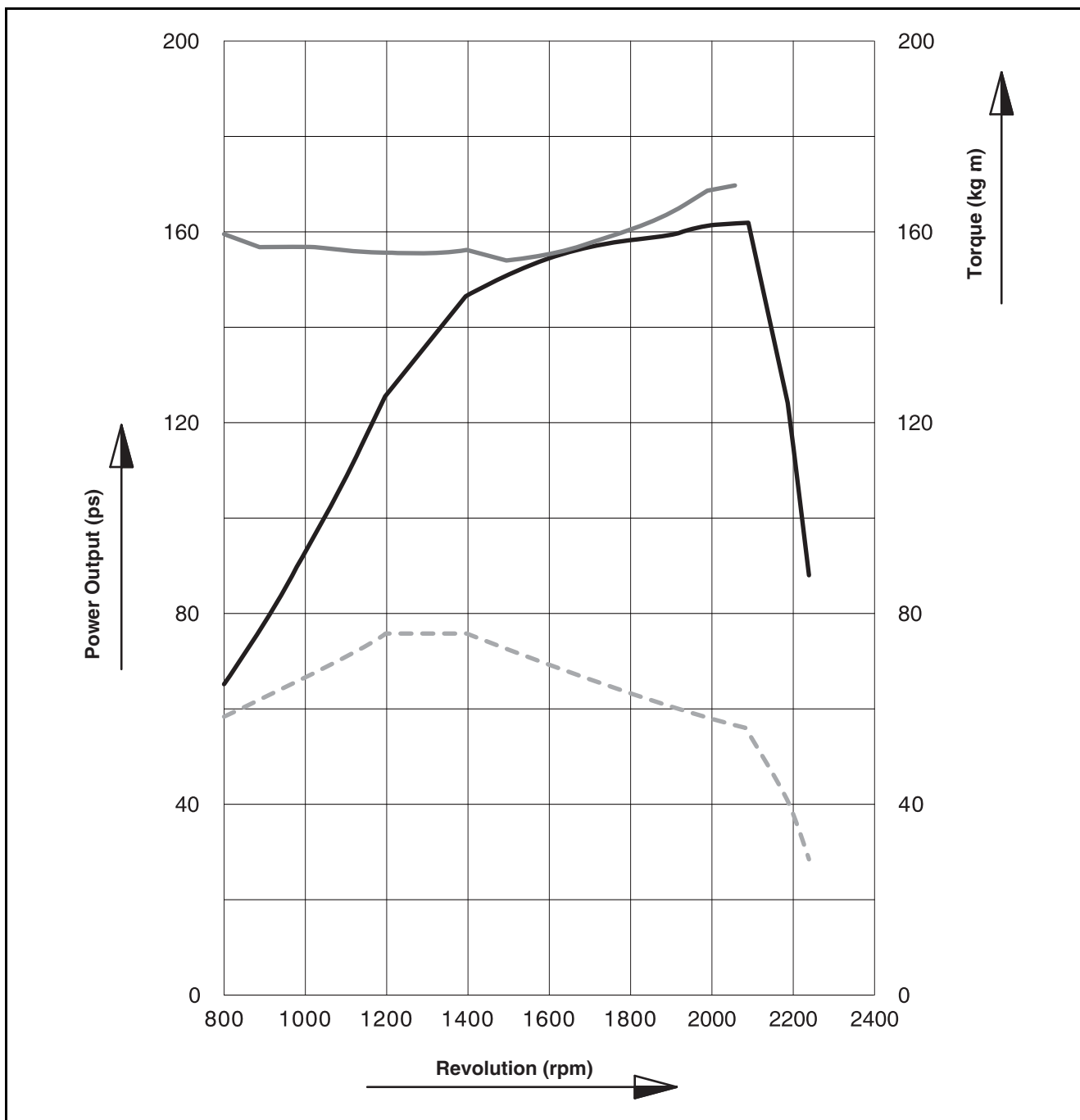

EDL06200006

Standard performance	KS-R0071
Engine power (rated)	161 PS / 2,100 rpm
Torque (max.)	75.0 kg·m / 1,400 rpm

### 3. Performance and specifications

Engine performance curve (DL06-LEL06)

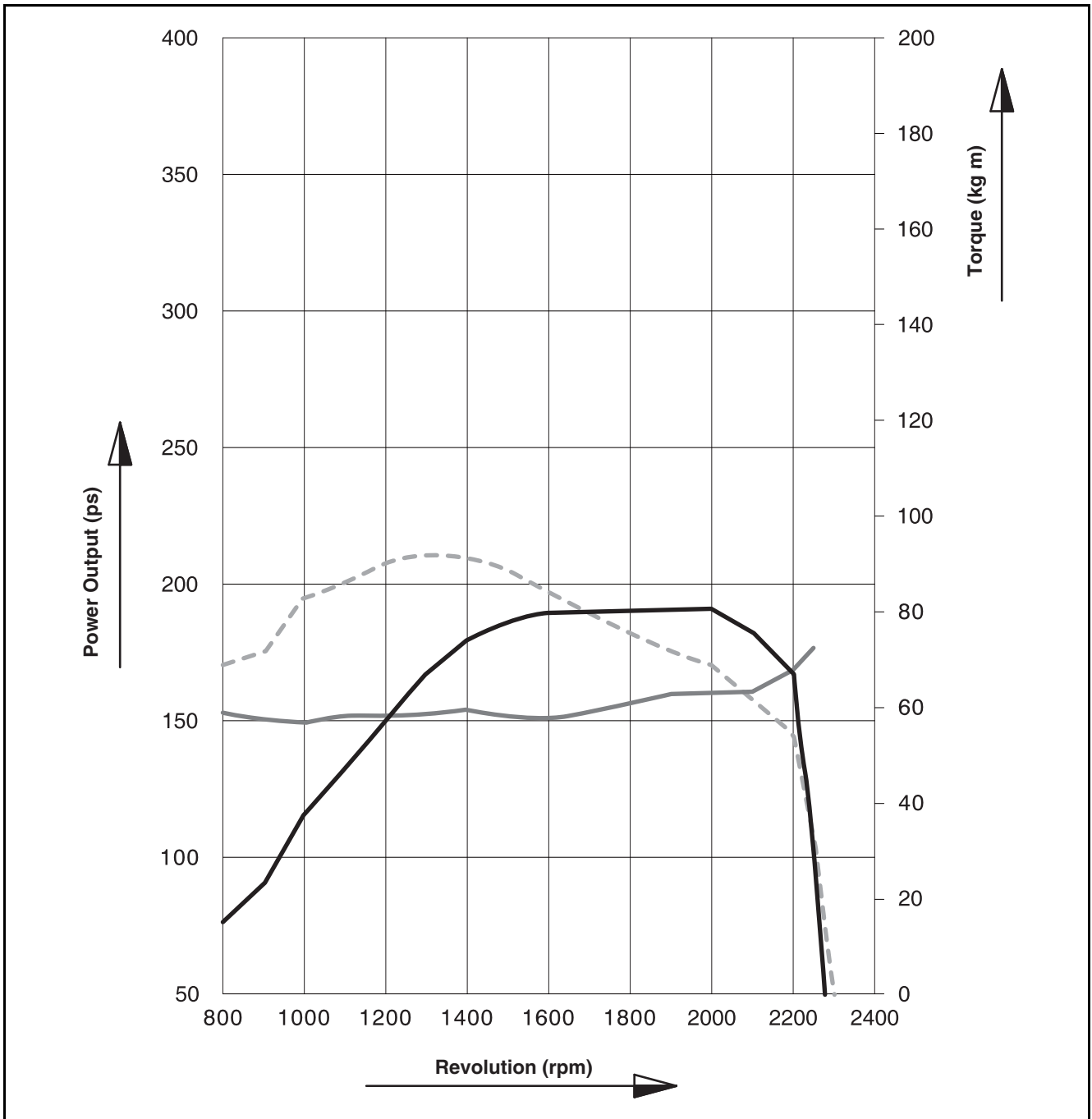

EDL06200007

Standard performance	KS-R0071
Engine power (rated)	192 PS / 2,000 rpm
Torque (max.)	92.0 kg-m / 1,400 rpm

### 3. Performance and specifications

#### Outside drawing of the engine (DL06-LEE00/03/04/06/07/08/11/12/14/15/17/19/20/22)

Note) The images shown represent the standard model; they do not include all models.

#### Structure diagram

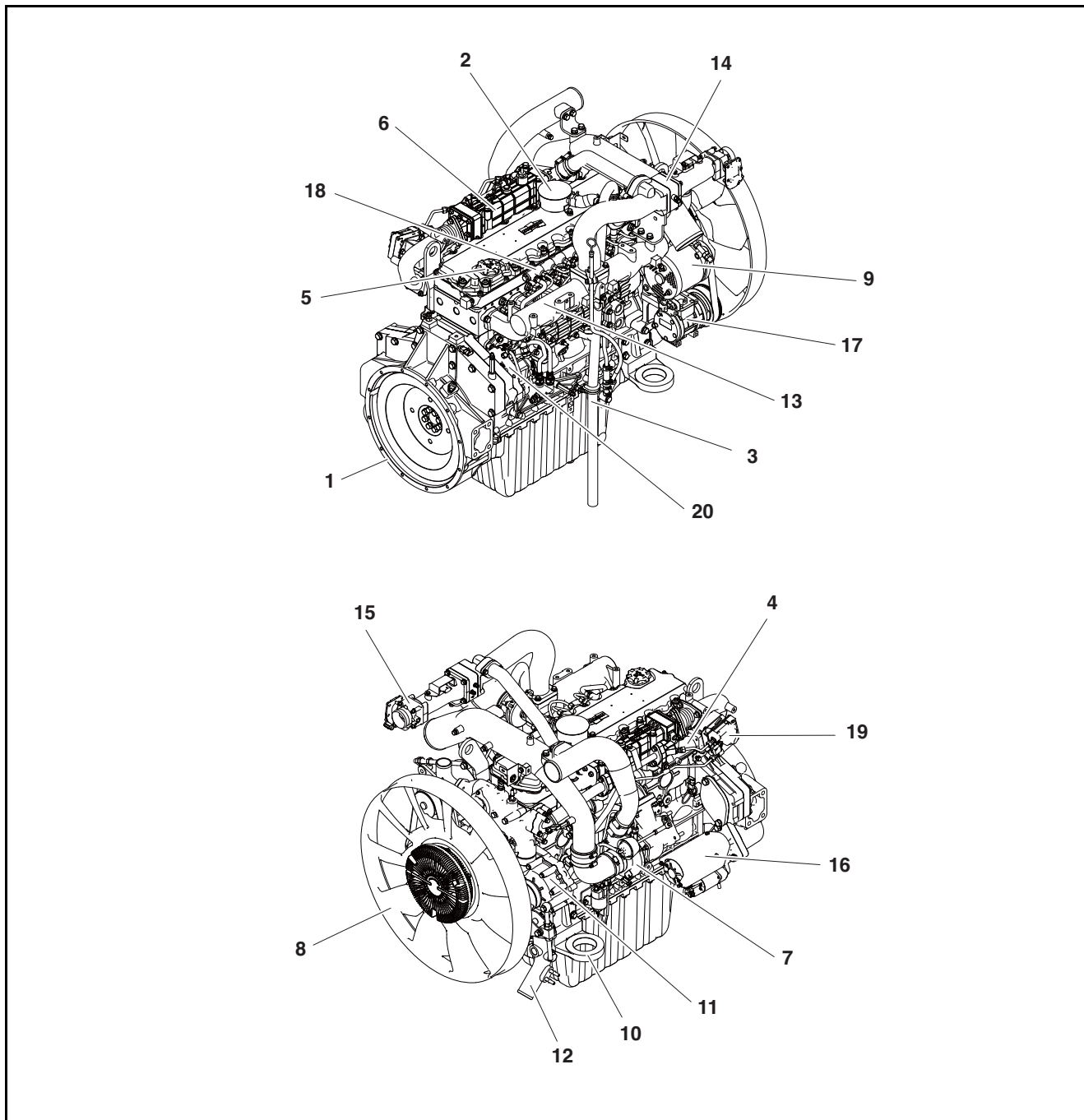

EK00283A

- |                     |                      |                     |                         |
|---------------------|----------------------|---------------------|-------------------------|
| 1. Flywheel housing | 6. EGR cooler        | 11. Water pump      | 16. Start motor         |
| 2. Breather         | 7. Turbocharger      | 12. Coolant pipe    | 17. Air compressor      |
| 3. Breather pipe    | 8. Cooling fan       | 13. Intake manifold | 18. Common rail         |
| 4. Exhaust manifold | 9. Alternator        | 14. Air heater      | 19. EGR valve           |
| 5. Oil filler inlet | 10. Mounting bracket | 15. Throttle valve  | 20. Fuel injection pump |

### 3. Performance and specifications

#### Left/Right sectional view

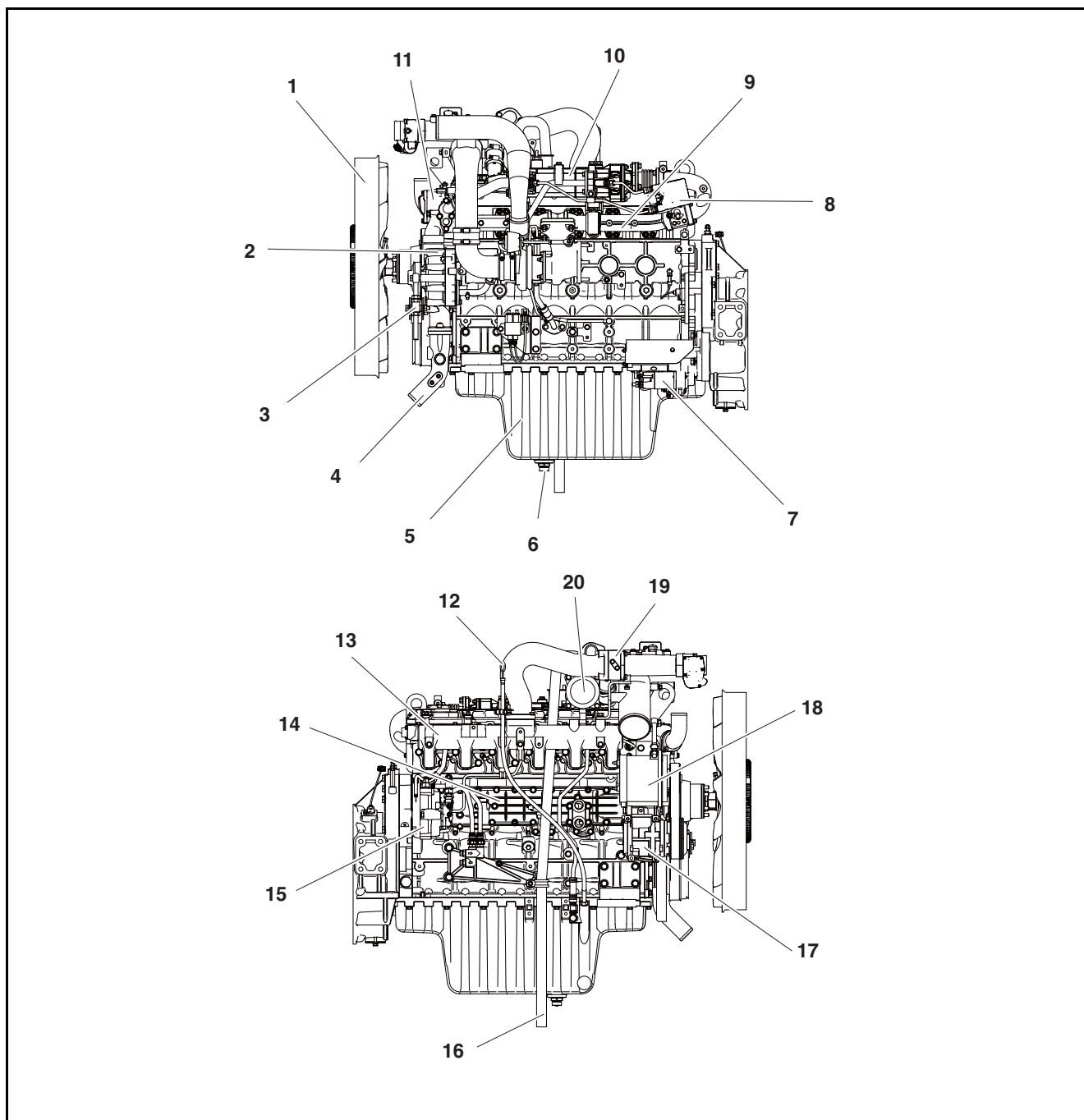

EK00284A

- |                 |                     |                         |                      |
|-----------------|---------------------|-------------------------|----------------------|
| 1. Cooling fan  | 6. Drain plug       | 11. Thermostat          | 16. Breather pipe    |
| 2. Water pump   | 7. Start motor      | 12. Oil level gauge     | 17. Air compressor   |
| 3. Eye bolt     | 8. EGR valve        | 13. Intake manifold     | 18. Alternator       |
| 4. Coolant pipe | 9. Exhaust manifold | 14. Oil cooler          | 19. Air heater       |
| 5. Oil pan      | 10. EGR cooler      | 15. Fuel injection pump | 20. Breather housing |

### 3. Performance and specifications

#### Top view

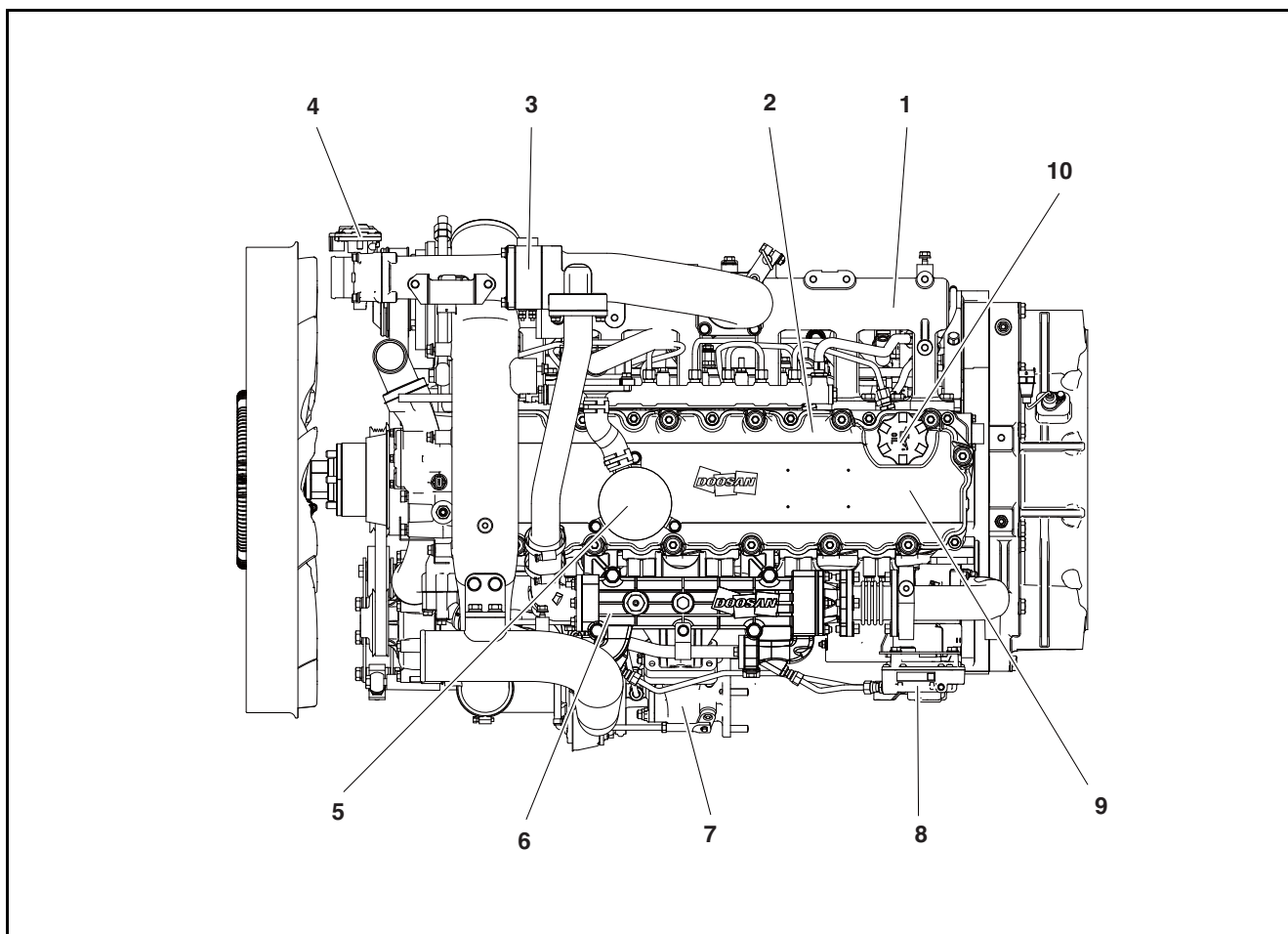

EK00285A

1. Intake manifold

4. Throttle valve

7. Turbocharger

10. Oil filler cap

2. Common rail

5. Breather

8. EGR valve

3. Air heater

6. EGR cooler

9. Cylinder head cover

### 3. Performance and specifications

#### Outside drawing of the engine (DL06-LEE01/09)

Note) The images shown represent the standard model; they do not include all models.

#### Structure diagram

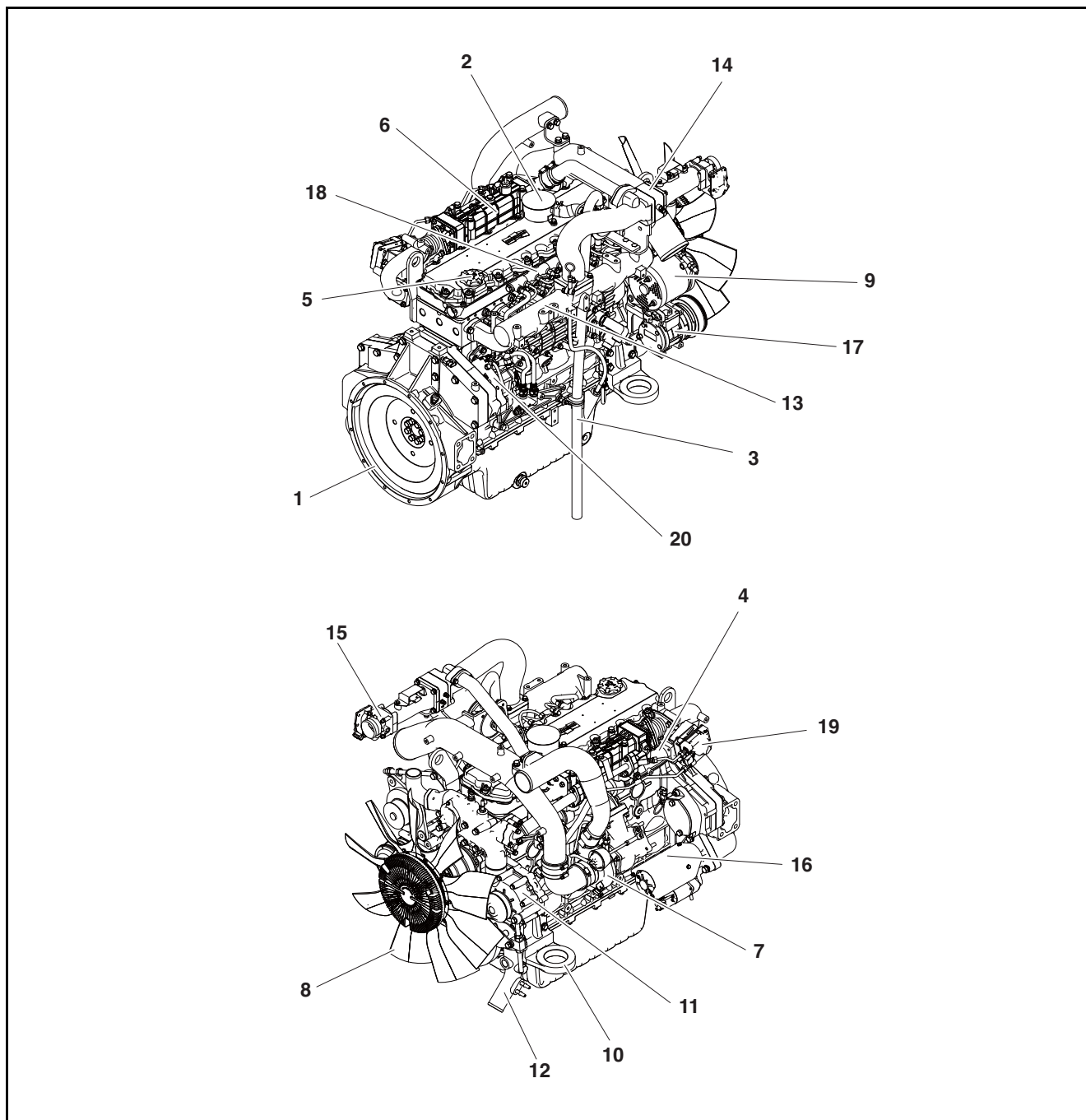

EK00286A

- |                     |                      |                     |                         |
|---------------------|----------------------|---------------------|-------------------------|
| 1. Flywheel housing | 6. EGR cooler        | 11. Water pump      | 16. Start motor         |
| 2. Breather         | 7. Turbocharger      | 12. Coolant pipe    | 17. Air compressor      |
| 3. Breather pipe    | 8. Cooling fan       | 13. Intake manifold | 18. Common rail         |
| 4. Exhaust manifold | 9. Alternator        | 14. Air heater      | 19. EGR valve           |
| 5. Oil filler inlet | 10. Mounting bracket | 15. Throttle valve  | 20. Fuel injection pump |

### 3. Performance and specifications

#### Left/Right sectional view

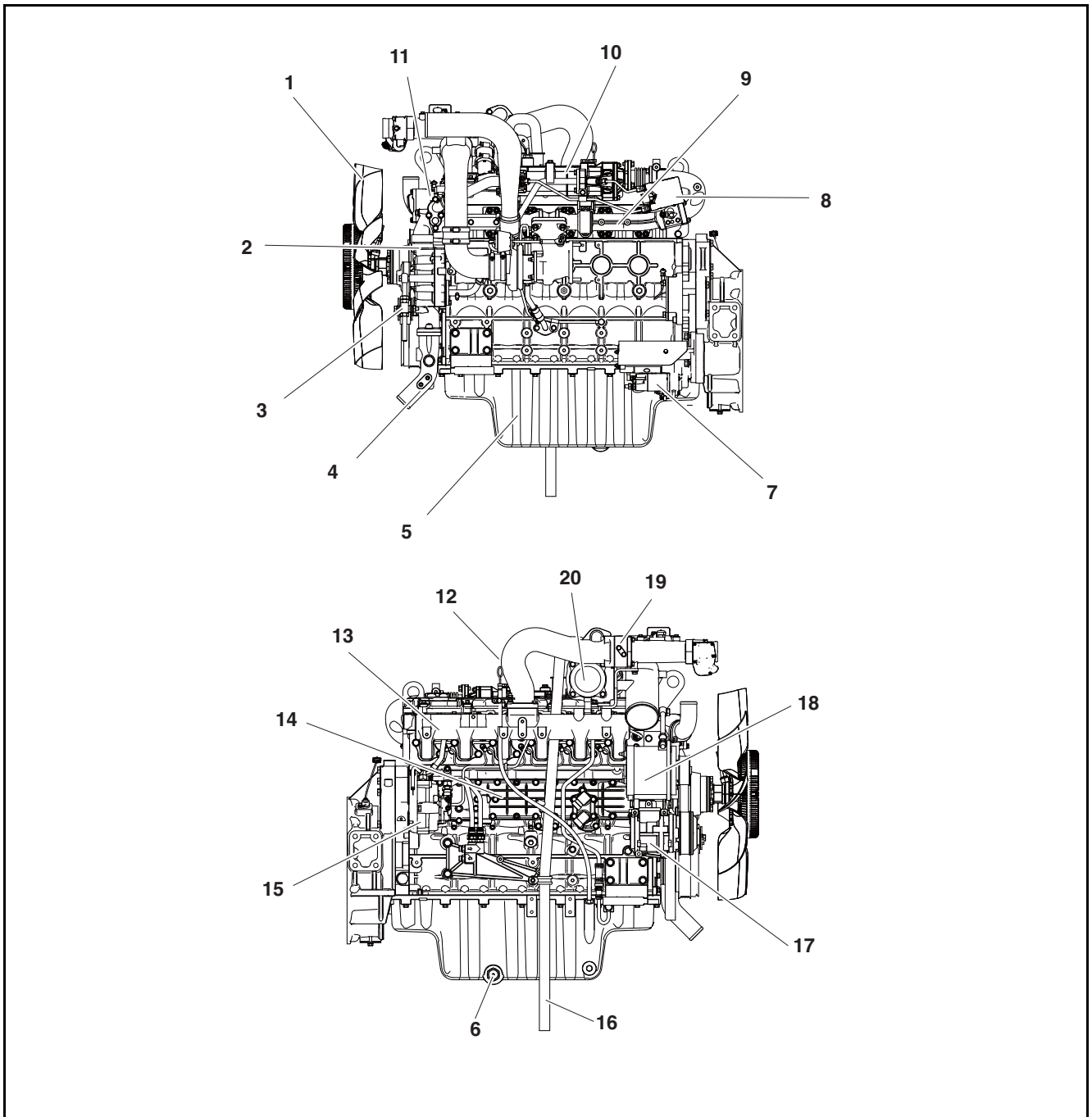

EK00287A

- |                 |                     |                         |                      |
|-----------------|---------------------|-------------------------|----------------------|
| 1. Cooling fan  | 6. Drain plug       | 11. Thermostat          | 16. Breather pipe    |
| 2. Water pump   | 7. Start motor      | 12. Oil level gauge     | 17. Air compressor   |
| 3. Eye bolt     | 8. EGR valve        | 13. Intake manifold     | 18. Alternator       |
| 4. Coolant pipe | 9. Exhaust manifold | 14. Oil cooler          | 19. Air heater       |
| 5. Oil pan      | 10. EGR cooler      | 15. Fuel injection pump | 20. Breather housing |



### 3. Performance and specifications

#### Top view

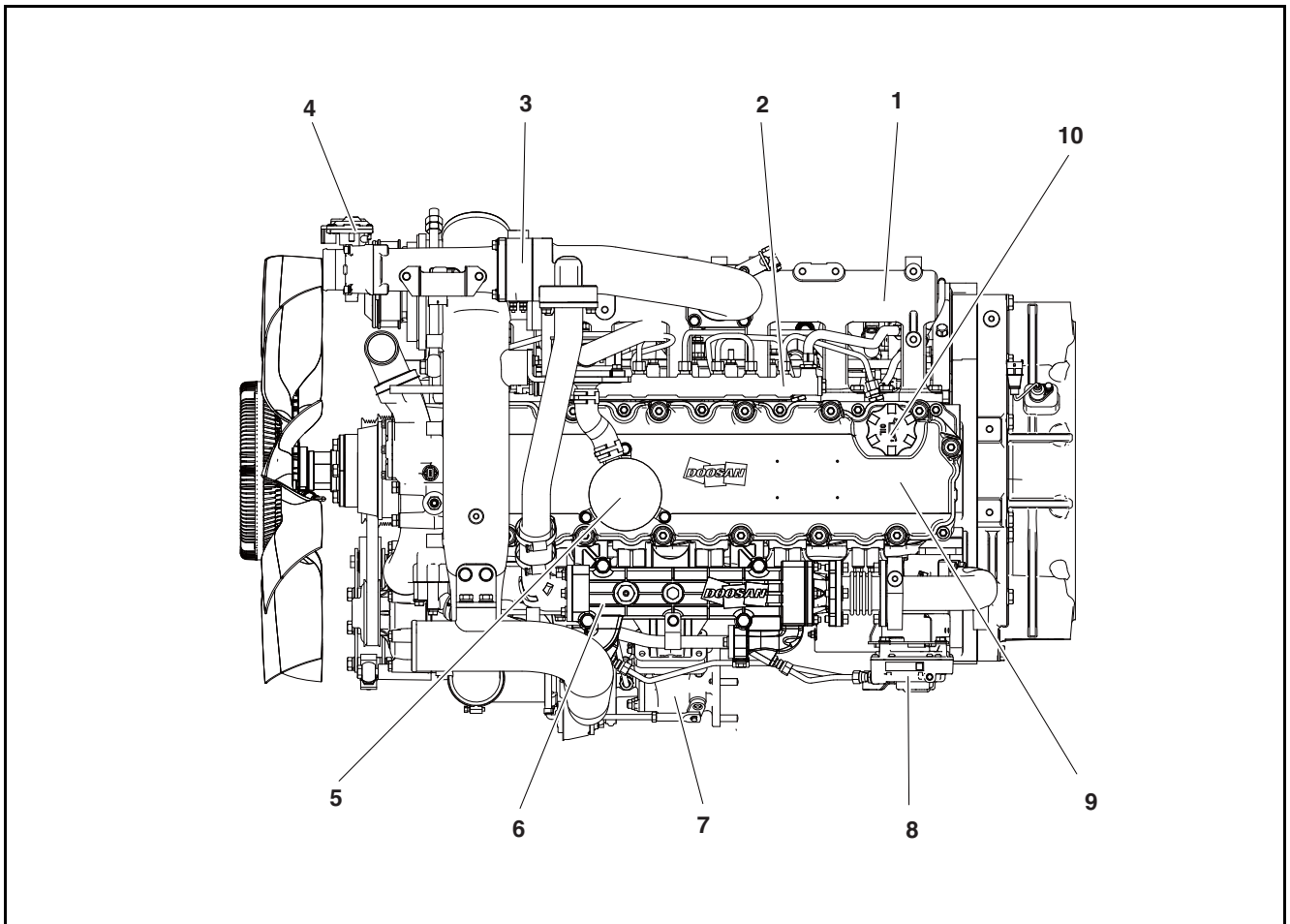

EK00288A

- |                    |                   |                        |                    |
|--------------------|-------------------|------------------------|--------------------|
| 1. Intake manifold | 4. Throttle valve | 7. Turbocharger        | 10. Oil filler cap |
| 2. Common rail     | 5. Breather       | 8. EGR valve           |                    |
| 3. Air heater      | 6. EGR cooler     | 9. Cylinder head cover |                    |

### 3. Performance and specifications

#### Outside drawing of the engine (DL06-LEE02/10/18)

Note) The images shown represent the standard model; they do not include all models.

#### Structure diagram

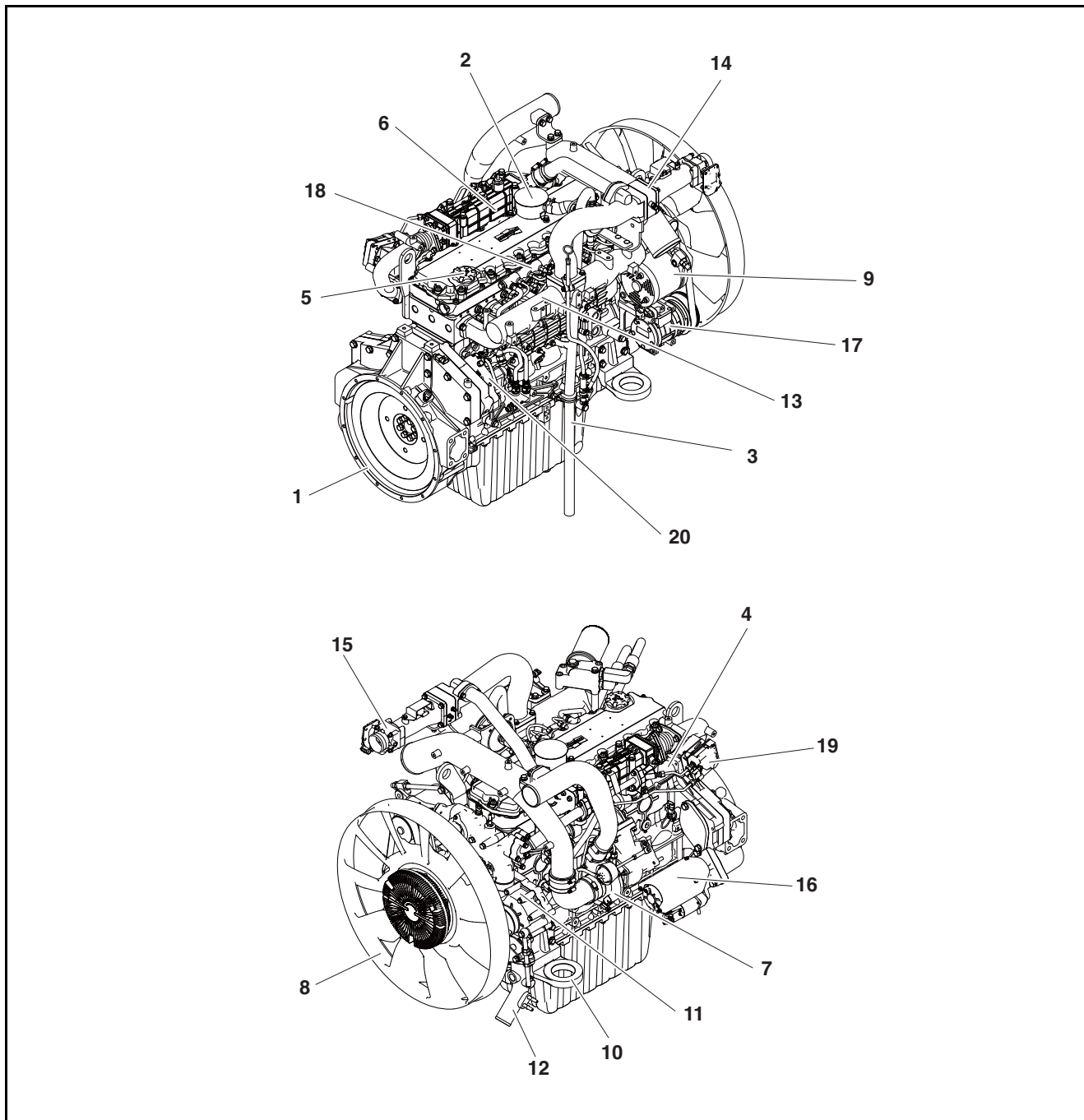

EK00289A

- |                     |                      |                     |                         |
|---------------------|----------------------|---------------------|-------------------------|
| 1. Flywheel housing | 6. EGR cooler        | 11. Water pump      | 16. Start motor         |
| 2. Breather         | 7. Turbocharger      | 12. Coolant pipe    | 17. Air compressor      |
| 3. Breather pipe    | 8. Cooling fan       | 13. Intake manifold | 18. Common rail         |
| 4. Exhaust manifold | 9. Alternator        | 14. Air heater      | 19. EGR valve           |
| 5. Oil filler inlet | 10. Mounting bracket | 15. Throttle valve  | 20. Fuel injection pump |

### 3. Performance and specifications

#### Left/Right sectional view

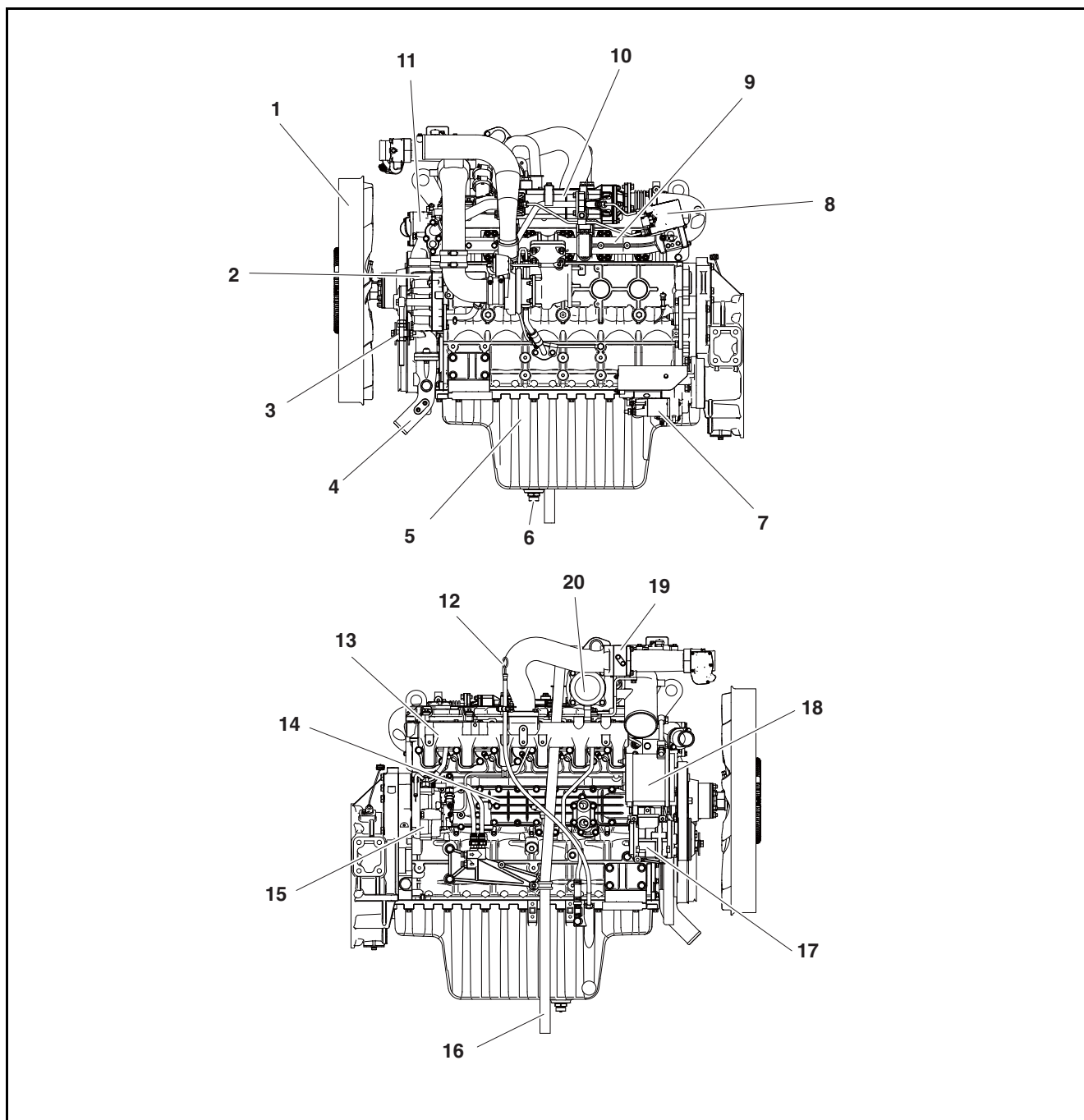

EK00290A

- |                 |                     |                         |                      |
|-----------------|---------------------|-------------------------|----------------------|
| 1. Cooling fan  | 6. Drain plug       | 11. Thermostat          | 16. Breather pipe    |
| 2. Water pump   | 7. Start motor      | 12. Oil level gauge     | 17. Air compressor   |
| 3. Eye bolt     | 8. EGR valve        | 13. Intake manifold     | 18. Alternator       |
| 4. Coolant pipe | 9. Exhaust manifold | 14. Oil cooler          | 19. Air heater       |
| 5. Oil pan      | 10. EGR cooler      | 15. Fuel injection pump | 20. Breather housing |

### 3. Performance and specifications

#### Top view

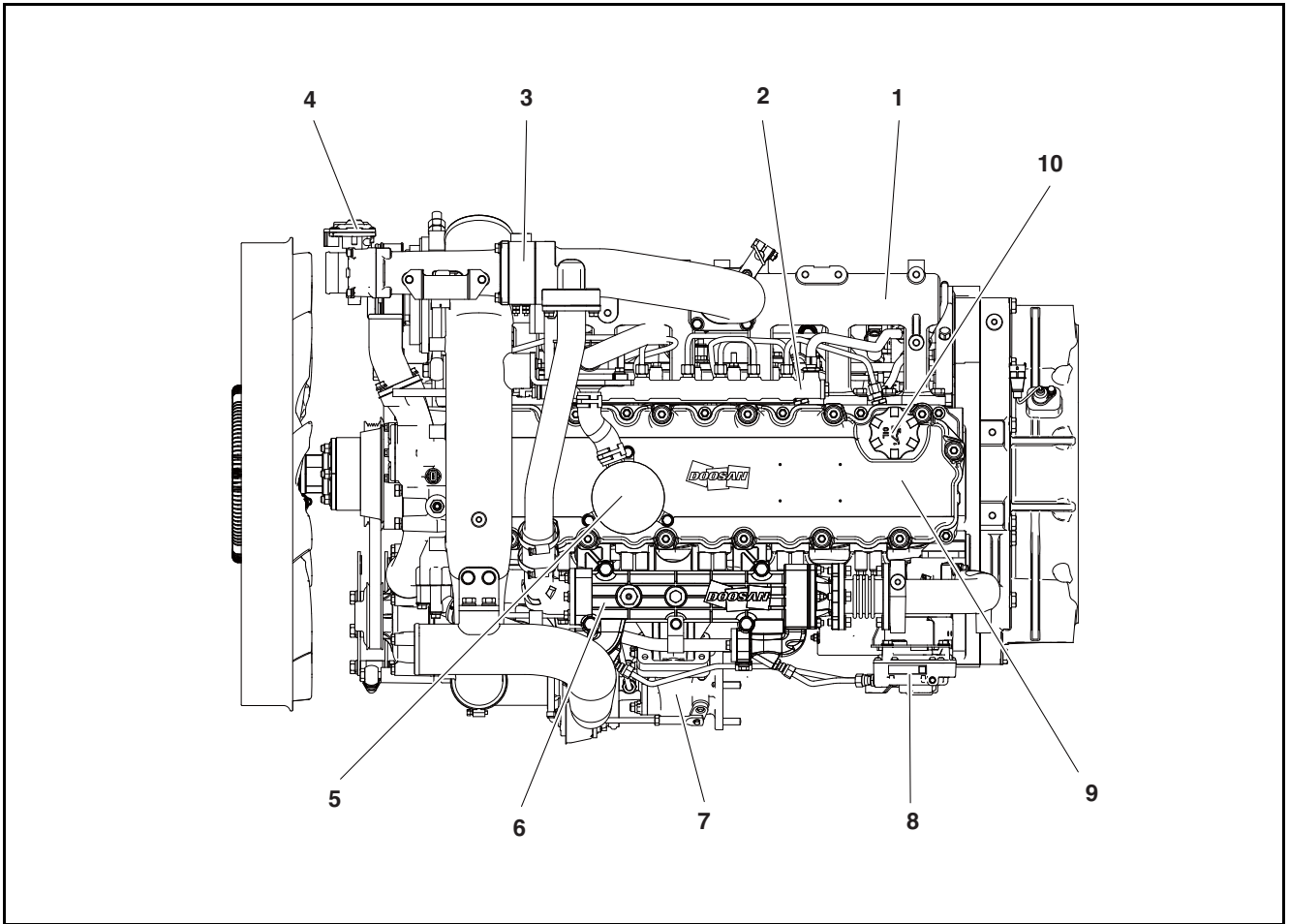

EK00291A

- |                    |                   |                        |                    |
|--------------------|-------------------|------------------------|--------------------|
| 1. Intake manifold | 4. Throttle valve | 7. Turbocharger        | 10. Oil filler cap |
| 2. Common rail     | 5. Breather       | 8. EGR valve           |                    |
| 3. Air heater      | 6. EGR cooler     | 9. Cylinder head cover |                    |

### 3. Performance and specifications

#### Outside drawing of the engine (DL06-LEE05/13/21)

Note) The images shown represent the standard model; they do not include all models.

#### Structure diagram

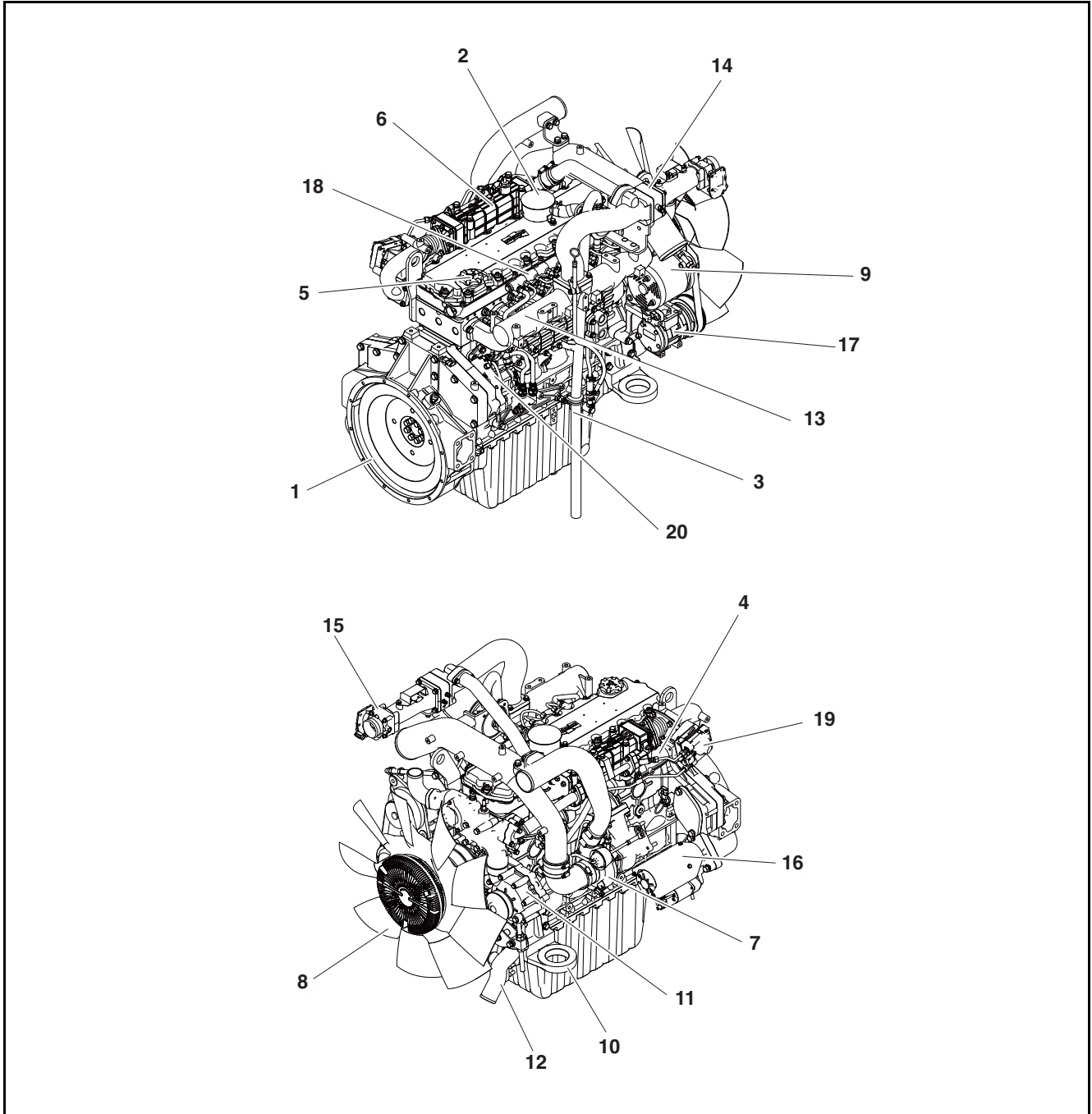

EK00292A

- |                     |                      |                     |                         |
|---------------------|----------------------|---------------------|-------------------------|
| 1. Flywheel housing | 6. EGR cooler        | 11. Water pump      | 16. Start motor         |
| 2. Breather         | 7. Turbocharger      | 12. Coolant pipe    | 17. Air compressor      |
| 3. Breather pipe    | 8. Cooling fan       | 13. Intake manifold | 18. Common rail         |
| 4. Exhaust manifold | 9. Alternator        | 14. Air heater      | 19. EGR valve           |
| 5. Oil filler inlet | 10. Mounting bracket | 15. Throttle valve  | 20. Fuel injection pump |

### 3. Performance and specifications

#### Left/Right sectional view

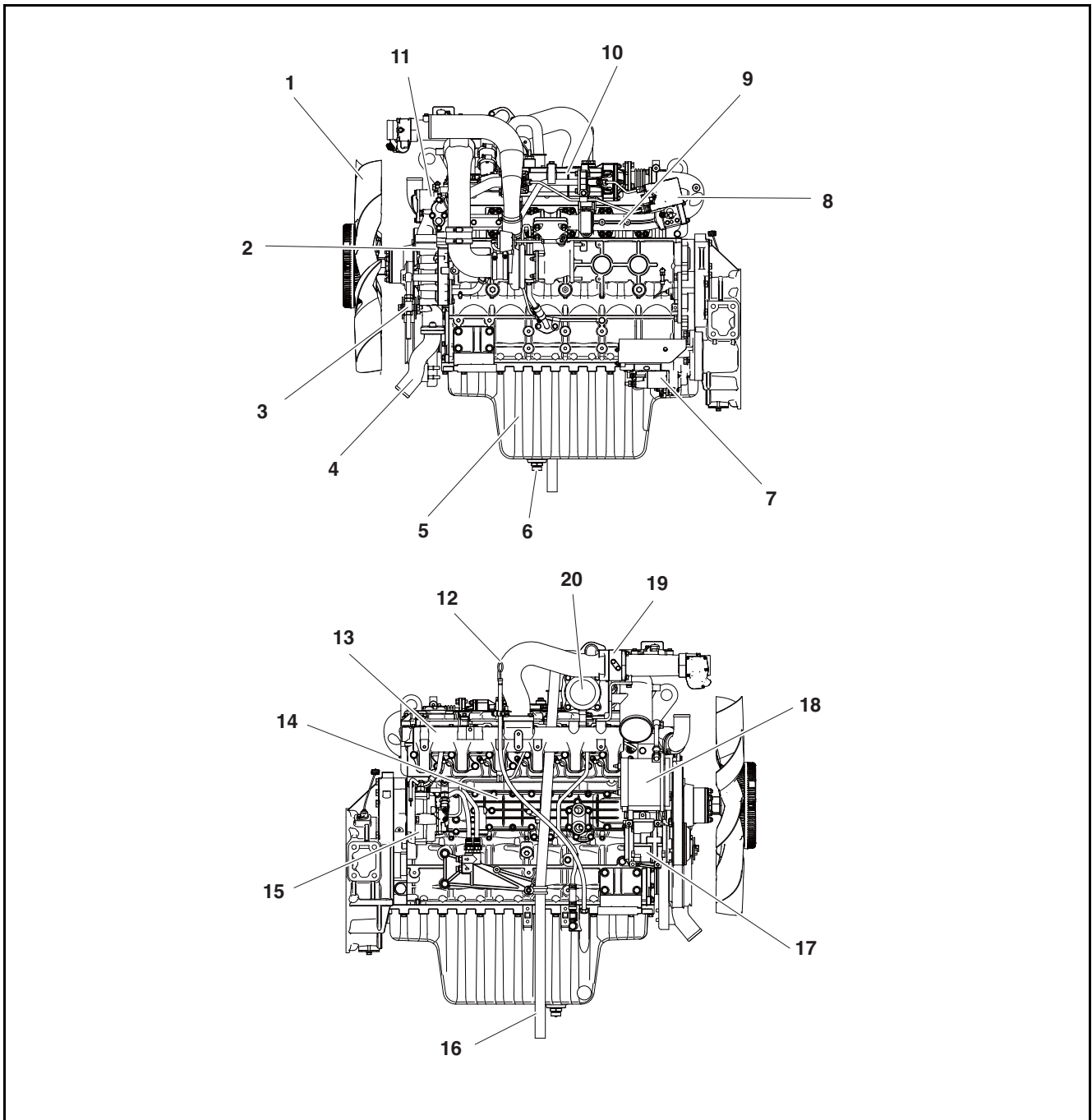

EK00293A

- |                 |                     |                         |                      |
|-----------------|---------------------|-------------------------|----------------------|
| 1. Cooling fan  | 6. Drain plug       | 11. Thermostat          | 16. Breather pipe    |
| 2. Water pump   | 7. Start motor      | 12. Oil level gauge     | 17. Air compressor   |
| 3. Eye bolt     | 8. EGR valve        | 13. Intake manifold     | 18. Alternator       |
| 4. Coolant pipe | 9. Exhaust manifold | 14. Oil cooler          | 19. Air heater       |
| 5. Oil pan      | 10. EGR cooler      | 15. Fuel injection pump | 20. Breather housing |

### 3. Performance and specifications

#### Top view

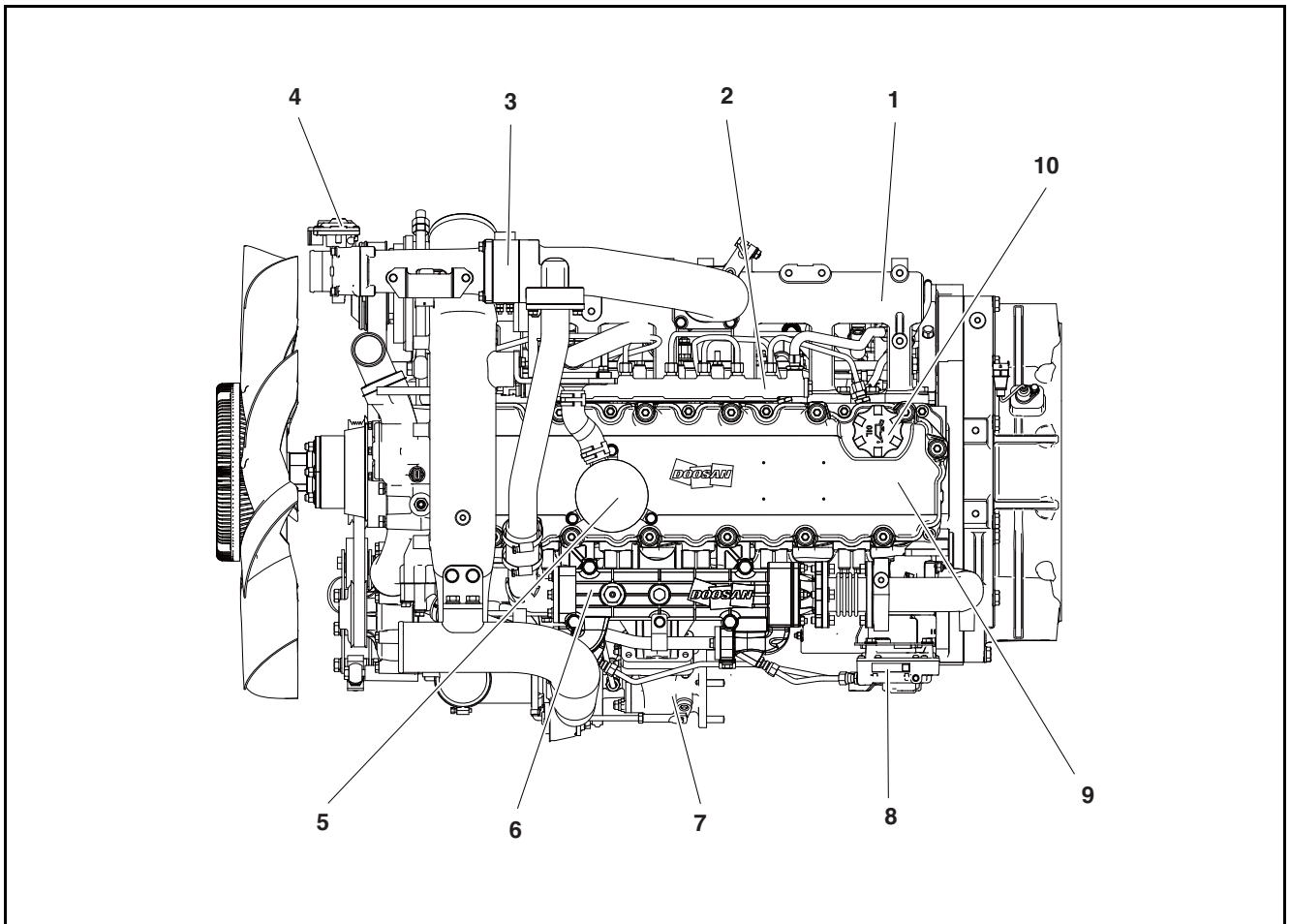

EK00294A

- |                    |                   |                        |                    |
|--------------------|-------------------|------------------------|--------------------|
| 1. Intake manifold | 4. Throttle valve | 7. Turbocharger        | 10. Oil filler cap |
| 2. Common rail     | 5. Breather       | 8. EGR valve           |                    |
| 3. Air heater      | 6. EGR cooler     | 9. Cylinder head cover |                    |

### 3. Performance and specifications

#### Outside drawing of the engine (DL06-LEF00/01)

Note) The images shown represent the standard model; they do not include all models.

#### Structure diagram

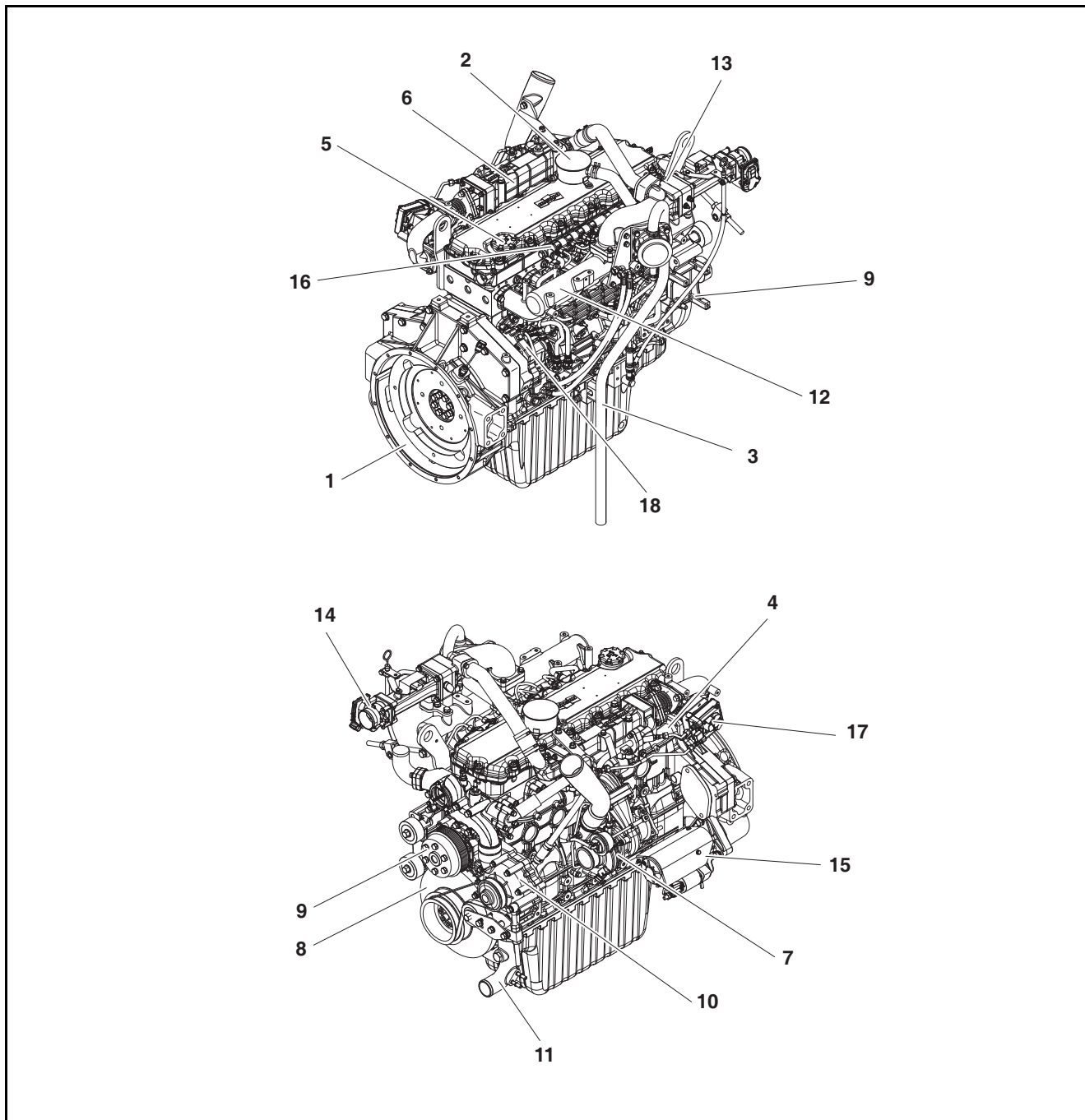

EK00283B

- |                     |                     |                     |                         |
|---------------------|---------------------|---------------------|-------------------------|
| 1. Flywheel housing | 6. EGR cooler       | 11. Intake manifold | 16. Common rail         |
| 2. Breather         | 7. Turbocharger     | 12. Air heater      | 17. EGR valve           |
| 3. Breather pipe    | 8. Mounting bracket | 13. Throttle valve  | 18. Fuel injection pump |
| 4. Exhaust manifold | 9. Water pump       | 14. Start motor     |                         |
| 5. Oil filler inlet | 10. Coolant pipe    | 15. Air compressor  |                         |



### 3. Performance and specifications

#### Left/Right sectional view

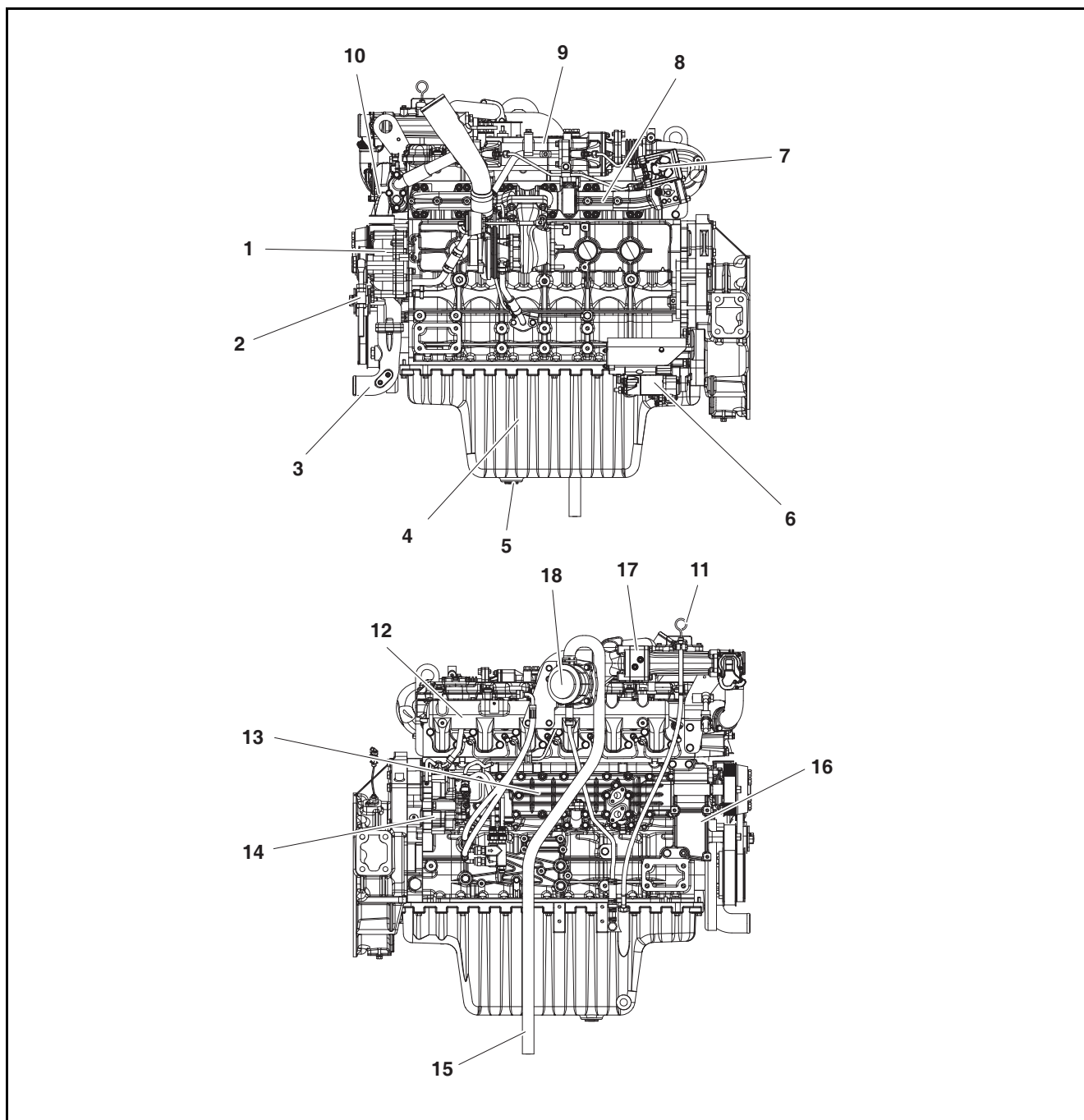

EK00284B

- |                 |                     |                         |                      |
|-----------------|---------------------|-------------------------|----------------------|
| 1. Water pump   | 6. Start motor      | 11. Oil level gauge     | 16. Mounting bracket |
| 2. Eye bolt     | 7. EGR valve        | 12. Intake manifold     | 17. Air heater       |
| 3. Coolant pipe | 8. Exhaust manifold | 13. Oil cooler          | 18. Breather housing |
| 4. Oil pan      | 9. EGR cooler       | 14. Fuel injection pump |                      |
| 5. Drain plug   | 10. Thermostat      | 15. Breather pipe       |                      |

### 3. Performance and specifications

#### Top view

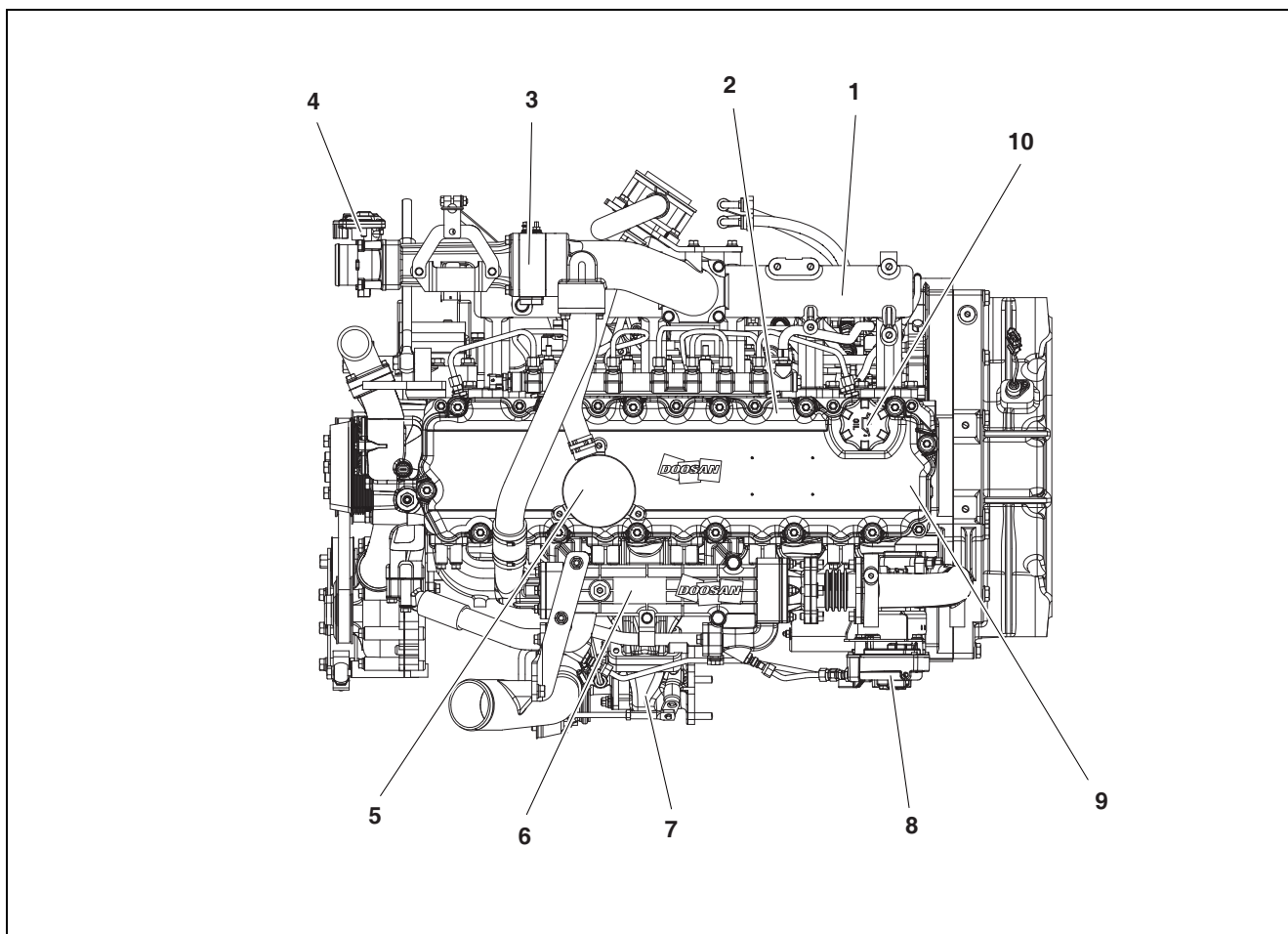

EK00297A

- |                    |                   |                        |                    |
|--------------------|-------------------|------------------------|--------------------|
| 1. Intake manifold | 4. Throttle valve | 7. Turbocharger        | 10. Oil filler cap |
| 2. Common rail     | 5. Breather       | 8. EGR valve           |                    |
| 3. Air heater      | 6. EGR cooler     | 9. Cylinder head cover |                    |

### 3. Performance and specifications

#### Outside drawing of the engine (DL06-LEL00/01)

Note) The images shown represent the standard model; they do not include all models.

#### Structure diagram

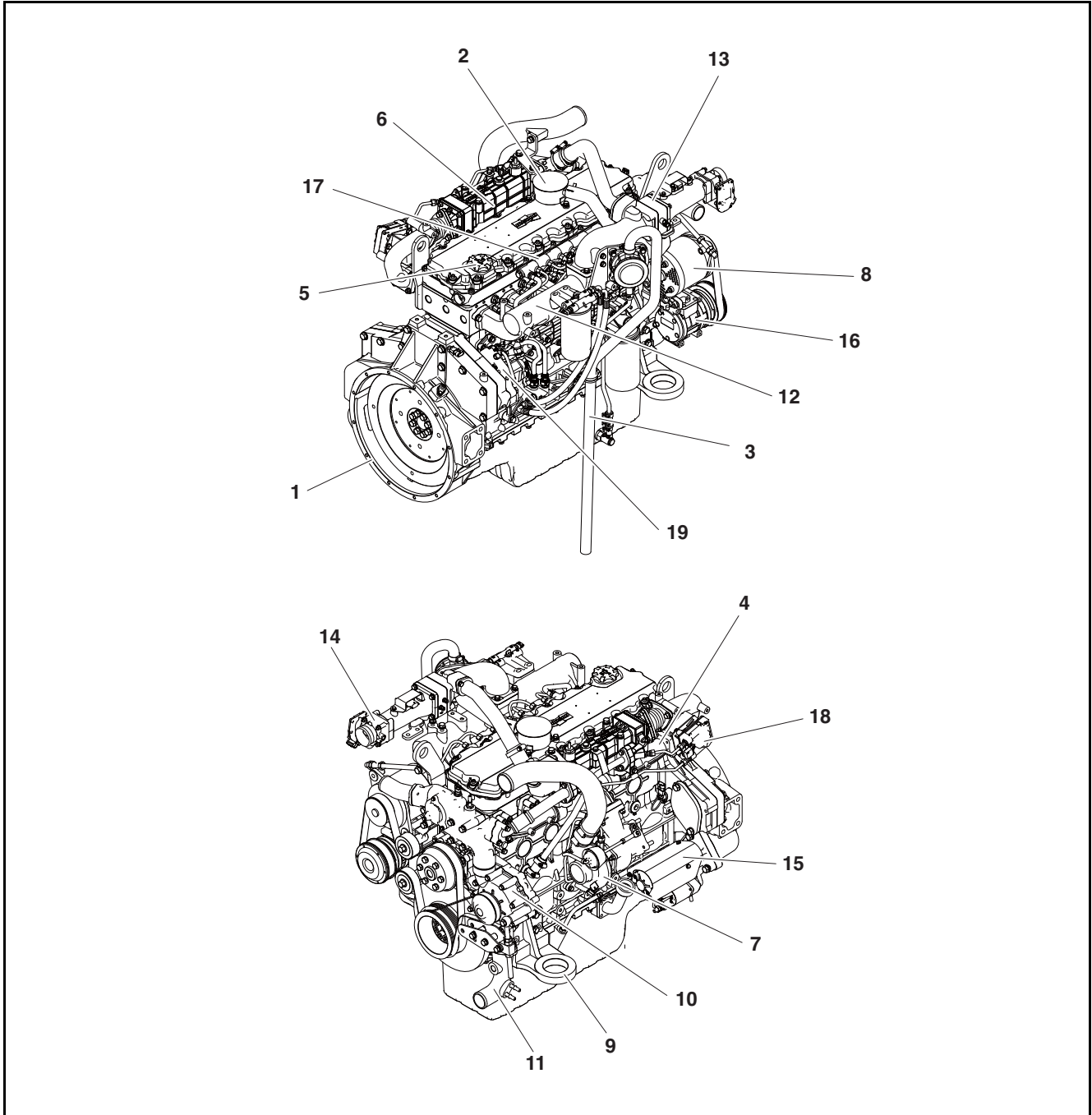

EK00295A

- |                     |                     |                     |                         |
|---------------------|---------------------|---------------------|-------------------------|
| 1. Flywheel housing | 6. EGR cooler       | 11. Coolant pipe    | 16. Air compressor      |
| 2. Breather         | 7. Turbocharger     | 12. Intake manifold | 17. Common rail         |
| 3. Breather pipe    | 8. Alternator       | 13. Air heater      | 18. EGR valve           |
| 4. Exhaust manifold | 9. Mounting bracket | 14. Throttle valve  | 19. Fuel injection pump |
| 5. Oil filler inlet | 10. Water pump      | 15. Start motor     |                         |

### 3. Performance and specifications

#### Left/Right sectional view

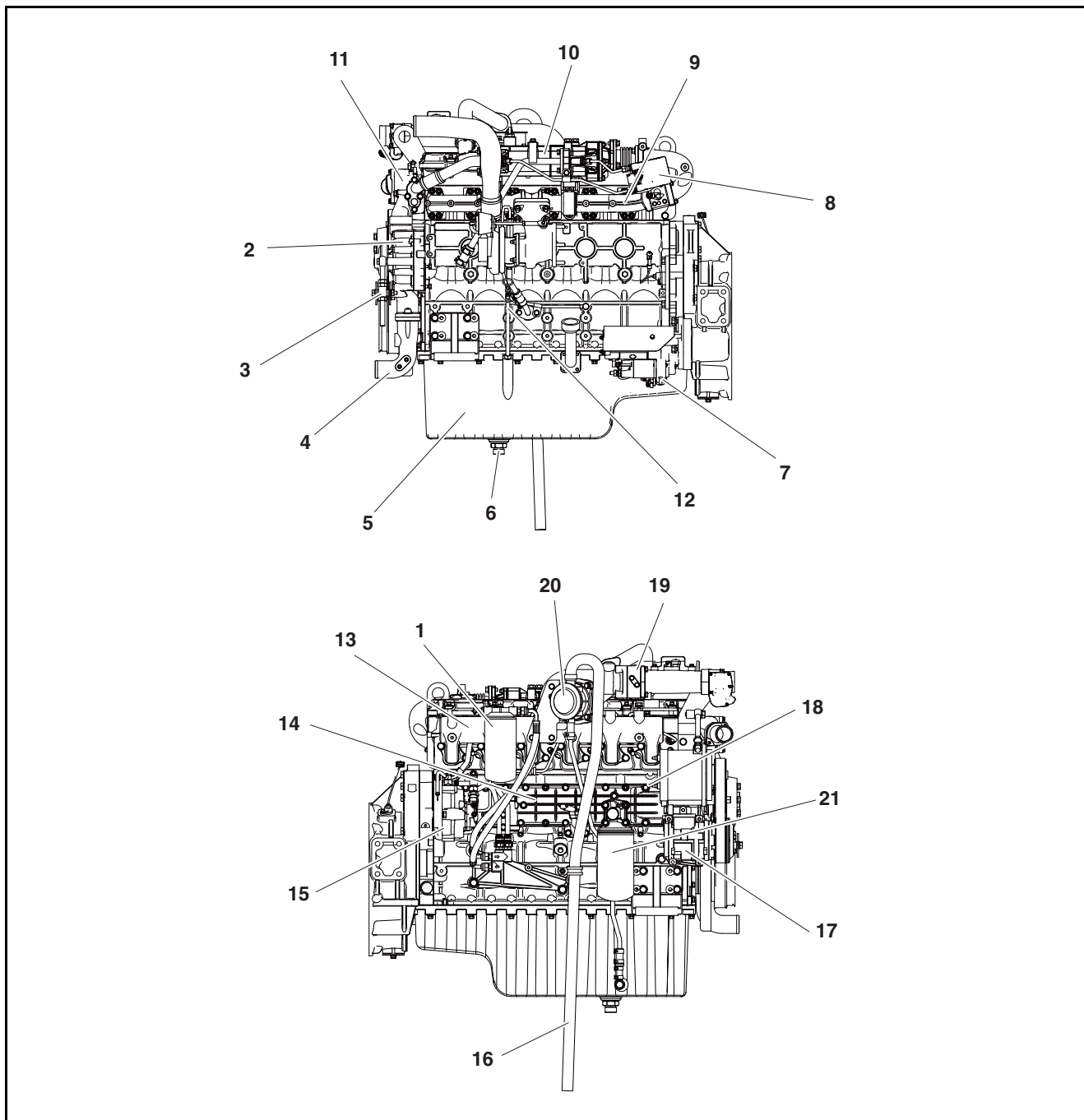

EK00296A

- |                 |                     |                         |                      |
|-----------------|---------------------|-------------------------|----------------------|
| 1. Fuel filter  | 7. Start motor      | 13. Intake manifold     | 19. Air heater       |
| 2. Water pump   | 8. EGR valve        | 14. Oil cooler          | 20. Breather housing |
| 3. Eye bolt     | 9. Exhaust manifold | 15. Fuel injection pump | 21. Oil filter       |
| 4. Coolant pipe | 10. EGR cooler      | 16. Breather pipe       |                      |
| 5. Oil pan      | 11. Thermostat      | 17. Air compressor      |                      |
| 6. Drain plug   | 12. Oil level gauge | 18. Alternator          |                      |

### 3. Performance and specifications

#### Top view

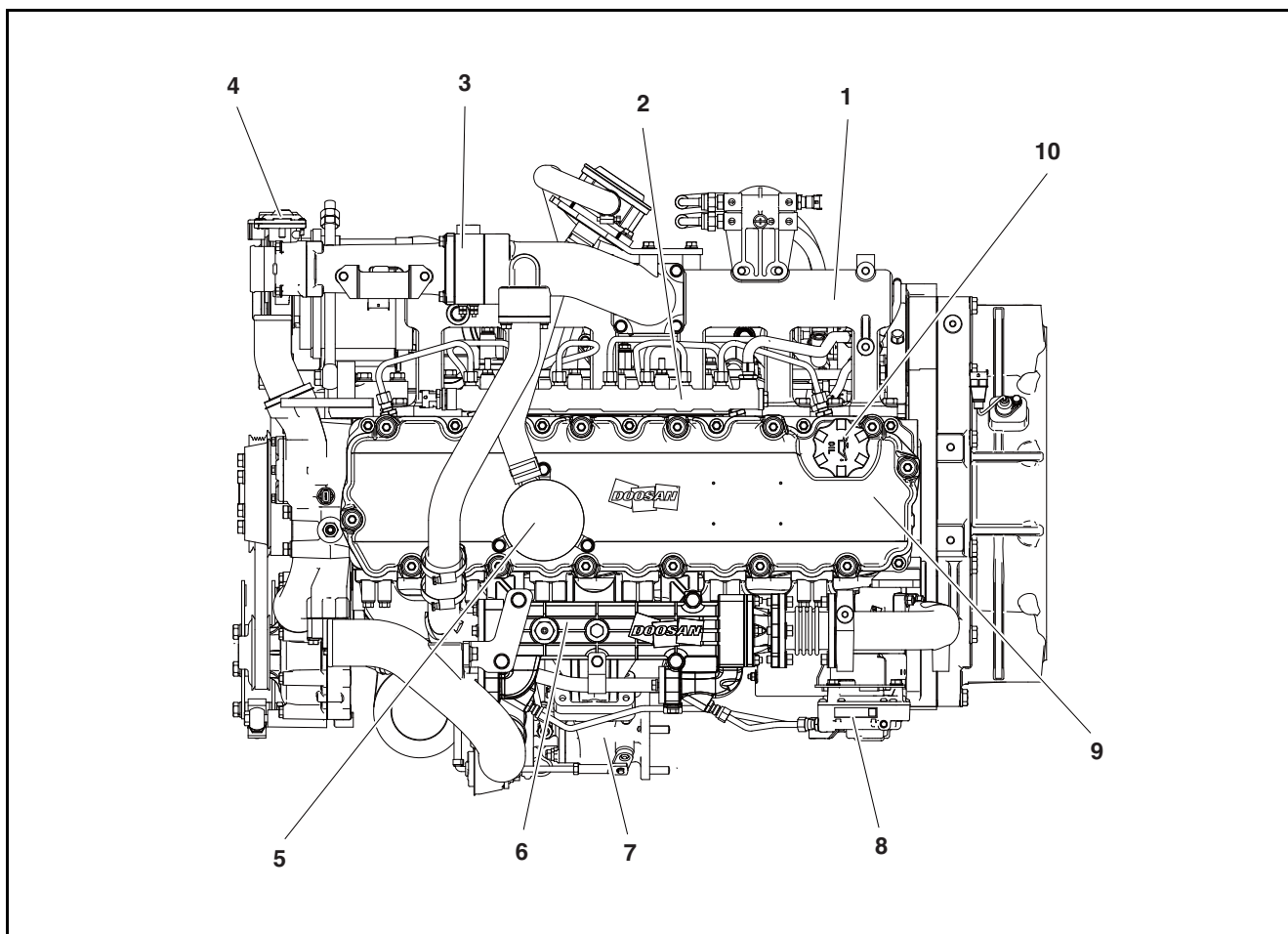

EK00297A

- |                    |                   |                        |                    |
|--------------------|-------------------|------------------------|--------------------|
| 1. Intake manifold | 4. Throttle valve | 7. Turbocharger        | 10. Oil filler cap |
| 2. Common rail     | 5. Breather       | 8. EGR valve           |                    |
| 3. Air heater      | 6. EGR cooler     | 9. Cylinder head cover |                    |

### 3. Performance and specifications

#### Outside drawing of the engine (DL06-LEL04/05/06)

Note) The images shown represent the standard model; they do not include all models.

#### Structure diagram

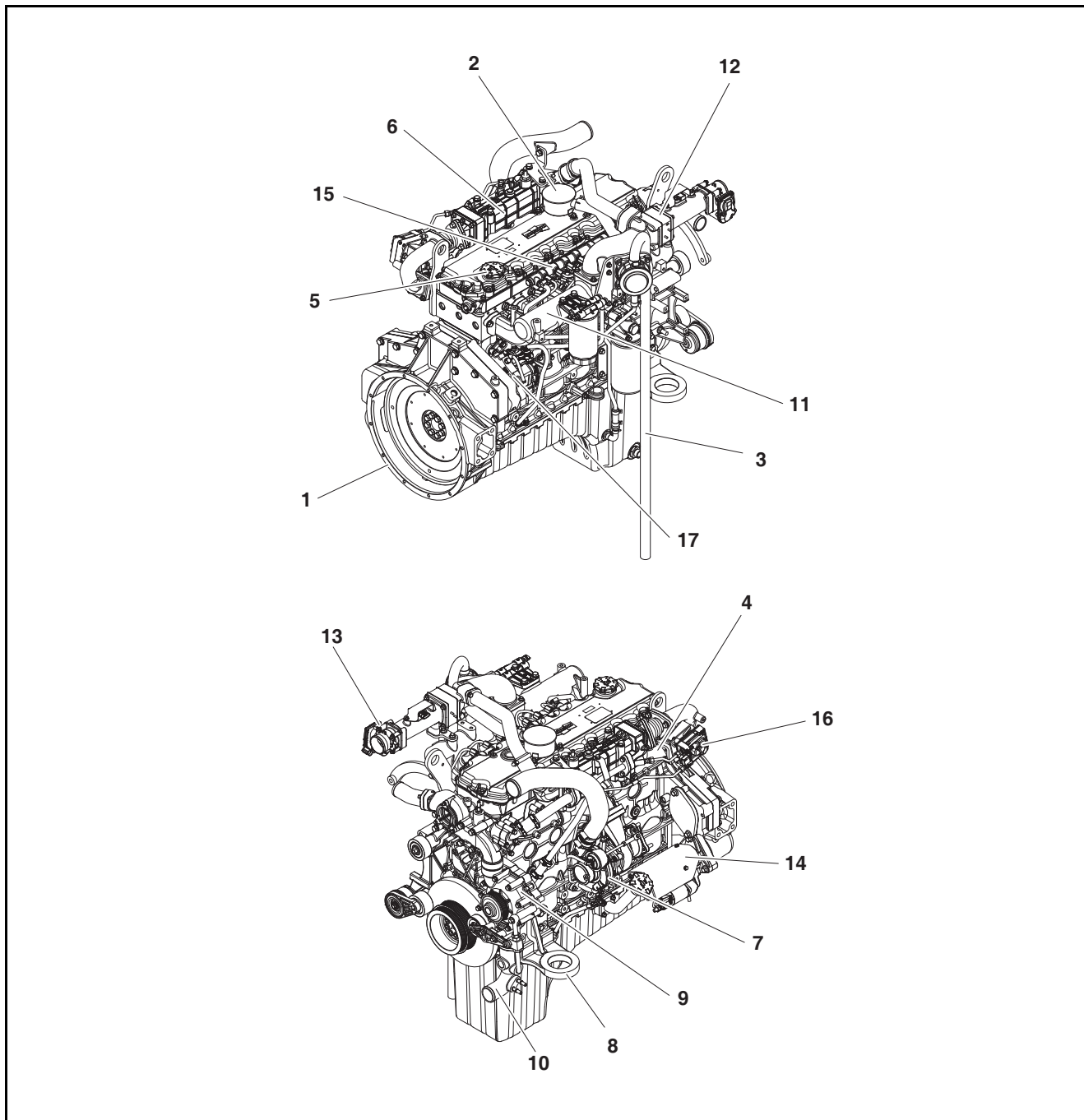

EDL06200001

- |                     |                     |                     |                         |
|---------------------|---------------------|---------------------|-------------------------|
| 1. Flywheel housing | 6. EGR cooler       | 11. Intake manifold | 16. EGR valve           |
| 2. Breather         | 7. Turbocharger     | 12. Air heater      | 17. Fuel injection pump |
| 3. Breather pipe    | 8. Mounting bracket | 13. Throttle valve  |                         |
| 4. Exhaust manifold | 9. Water pump       | 14. Start motor     |                         |
| 5. Oil filler inlet | 10. Coolant pipe    | 15. Common rail     |                         |

### 3. Performance and specifications

#### Left/Right sectional view

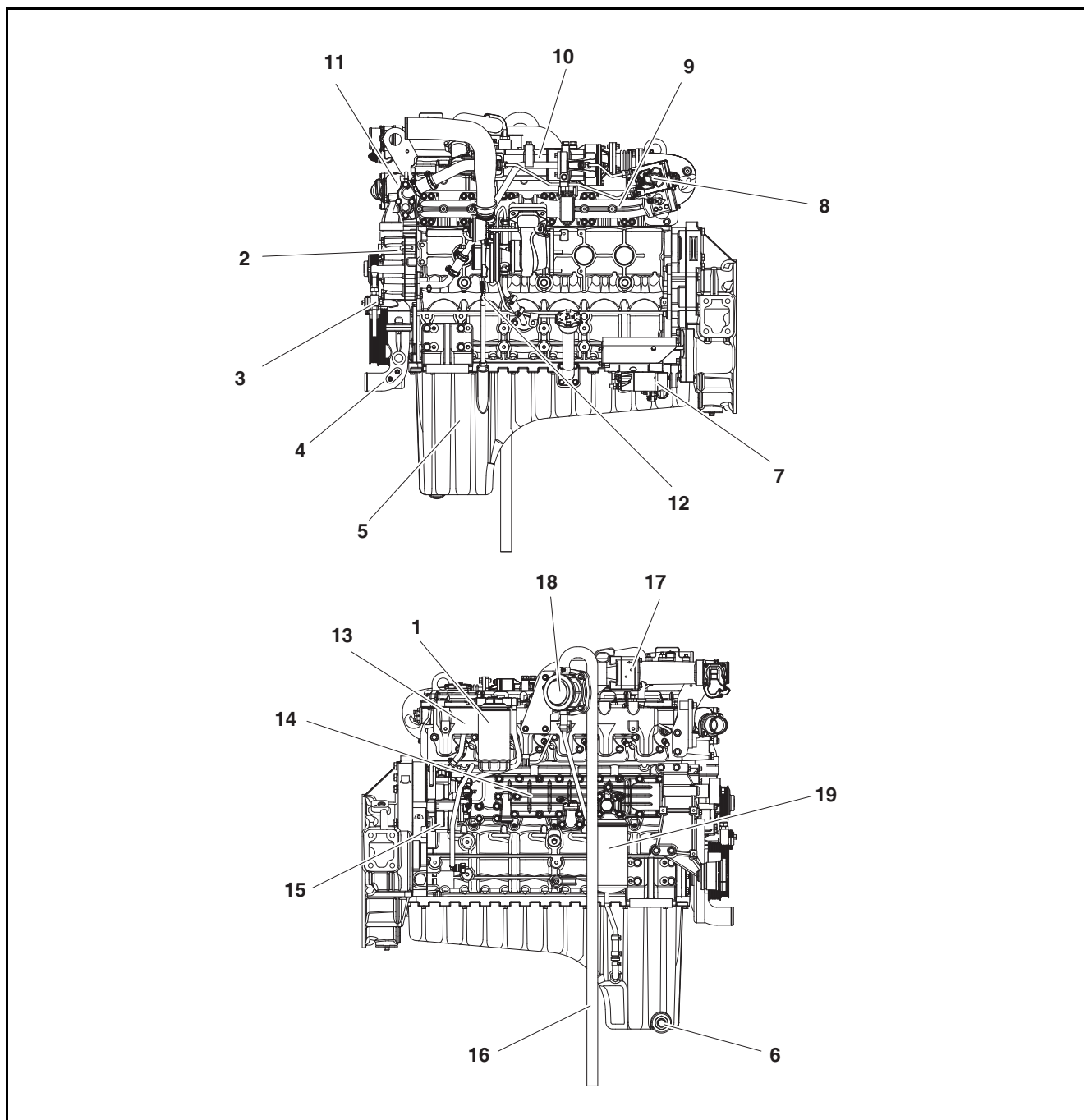

EDL06200002

- |                 |                     |                         |                      |
|-----------------|---------------------|-------------------------|----------------------|
| 1. Fuel filter  | 6. Drain plug       | 11. Thermostat          | 16. Breather pipe    |
| 2. Water pump   | 7. Start motor      | 12. Oil level gauge     | 17. Air heater       |
| 3. Eye bolt     | 8. EGR valve        | 13. Intake manifold     | 18. Breather housing |
| 4. Coolant pipe | 9. Exhaust manifold | 14. Oil cooler          | 19. Oil filter       |
| 5. Oil pan      | 10. EGR cooler      | 15. Fuel injection pump |                      |

### 3. Performance and specifications

#### Top view

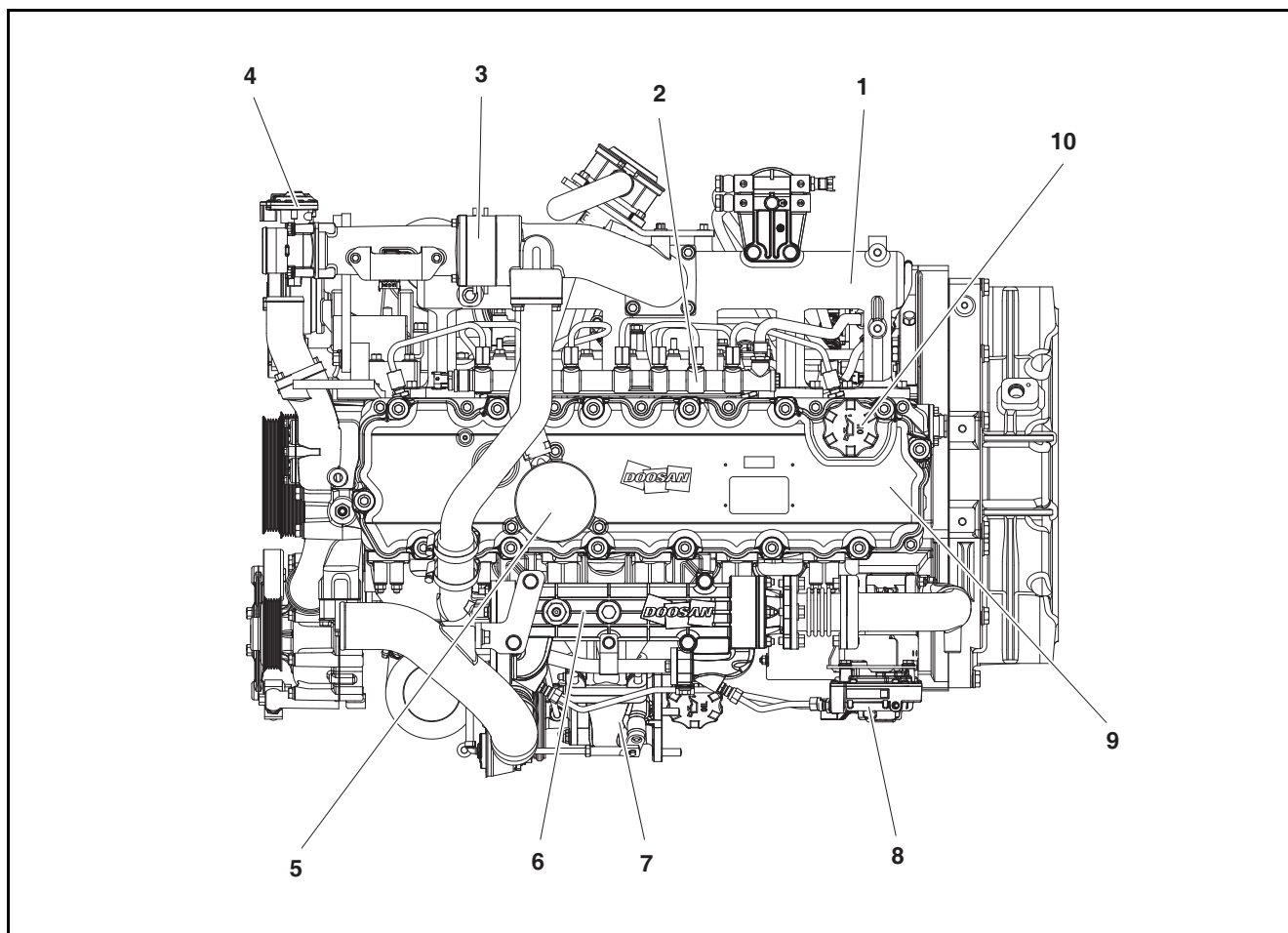

EDL06200003

- |                    |                   |                        |                    |
|--------------------|-------------------|------------------------|--------------------|
| 1. Intake manifold | 4. Throttle valve | 7. Turbocharger        | 10. Oil filler cap |
| 2. Common rail     | 5. Breather       | 8. EGR valve           |                    |
| 3. Air heater      | 6. EGR cooler     | 9. Cylinder head cover |                    |



### 3. Performance and specifications

#### Engine identification number

##### Engine code and manufacturing number

The engine code and manufacturing number are required for a warranty claim and part order.

##### Engine number engraving

- Type 1

(A) (B) (C)

- A. Engine model SUFFIX(5 digits)
- B. Production Year(1 digit)
- C. Serial Number(5 digits)

- Type 2

(A) (B) (C) (D)

- A. Sales Model name(4~7 digits)
- B. Production Year(1 digit)
- C. Serial Number(5 digits)
- D. After engine model SUFFIX(2 digits)

- Type 3

(A) (B) (C) (D) (E)

- A. Sales Model name(5 digits)
- B. Engine output(3 digits)
- C. Production Year(1 digit)
- D. Serial Number(5 digits)
- E. After engine model SUFFIX(2 digits)

- Type 4

(A) (B) (C)

- A. New representative specification (9 digits)
- B. Production Year(1 digit)
- C. Serial Number(5 digits)

- Type 5

(A) (B) (C) (D)

- A. Sales Model name(4~7 digits)
- B. Production Year(1 digit)
- C. Serial Number(5 digits)
- D. After new representative specification(3 digits)

- Type 6

(A) (B) (C) (D) (E)

- A. Sales Model name(5 digits)
- B. Engine output(3 digits)
- C. Production Year(1 digit)
- D. Serial Number(5 digits)
- E. After new representative specification(3 digits)

### 3. Performance and specifications

---

## 4. Regular inspection

General information .....	69
General information .....	69
Routine inspection .....	69
Regular inspection table .....	70
General condition.....	70
Cooling system .....	71
General information .....	71
Coolant standards.....	71
Coolant level .....	71
Checking the coolant .....	71
Measurement of coolant concentration.....	72
Replenishment of coolant .....	73
Replacement of coolant .....	73
Cleaning cooling circuit.....	74
Lubrication system .....	75
General information .....	75
Engine oil specifications.....	76
Engine oil capacity .....	77
Checking engine oil.....	77
Adding engine oil .....	78
Changing engine oil .....	78
Fuel system .....	80
General information .....	80
Fuel standards .....	80
Fuel filter .....	80
Air bleeding in the fuel circuit.....	80
Intake/Exhaust system .....	81
General information .....	81
Cleaning of air filter .....	81
Cleaning of the air filter element .....	81
Replacement of the air filter element .....	82
Turbocharger .....	83
Cylinder block/head .....	84
Valve clearance .....	84
Valve clearance adjustment procedure.....	84
Electric system .....	87

Battery.....	87
Others/Driving system .....	88
Belt tension .....	88

### General information

#### General information

As time passes after purchasing an engine, each of the engines parts age and initial engine performance cannot be maintained.

Regular inspection and replacement according to the recommended regular inspection table allows you to maintain an engine with the optimum conditions and best performance for a long period and prevent unexpected accidents in advance.

Users are responsible for the proper operation and maintenance of engines. Engines should be inspected and replaced by officially-certified technicians in a workspace with the specified tools and facilities. Observe the following instructions to perform inspections.

1. Perform inspections on a flat floor without a slope.
2. Excluding extreme circumstances, only perform inspection while the engine is stopped.
3. Disconnect the '-' terminal of the battery before performing an inspection.
4. Perform inspection in a well ventilated space.
5. Use a wooden prop or lift when working under the engine.

---

### DANGER

---

- **Wait until the engine is sufficiently cooled before starting inspection after operating the engine. Otherwise, you may be burned.**
  - **You may be poisoned by the emission when starting an engine in a closed space. Perform inspection at the well-ventilate space.**
  - **Unless absolutely compelled, do not perform inspection under an engine.**
  - **Do not be close to fire when inspecting an engine. Fuel, oil, or batteries may generate gas, causing fire.**
  - **If inspecting the engine while it is running, do not wear accessories such as necklaces, rings, watches or gloves. Such accessories may become stuck in rotating parts while the engine is running and may cause serious bodily injury.**
  - **Individuals who use a mechanical heart or artificial internal organ should not enter the area near an engine while it is running. The high-voltage current of the injectors or ECU may cause abnormal operation of such equipment.**
- 

---

### CAUTION

---

- **Incorrect inspection methods may cause of engine faults.**
  - **Cleaning an engine with liquids such as water or wax may cause breakdown of electrical parts.**
  - **Be careful when handling batteries, cables, and electrical wirings because current flows through those parts.**
  - **Do not put heavy things or apply excessive force or impact on the fuel-related units.**
  - **Make sure that you connect the battery terminal ('+' and '-') to the right terminal. Connecting the '+' and '-' terminals to the wrong terminal may cause damage to the electrical unit parts and fire.**
- 

#### Routine inspection

Routine inspection is an inspection performed by an engine operator before operating the engine. It should be performed to protect operator's safety, as well as the engine.

The following is a minimal check list.

1. Check whether the engine smoothly starts and the levels of fuel, oil, and coolant are within the normal range.
2. Check if any discharged emissions are colored and if the exhaust contains toxic gas elements.
3. Check whether abnormal noise occurs after starting an engine or not.
4. Check whether oil or water is leaking.

## 4. Regular inspection

### Regular inspection table

The maintenance schedule may be different by driving conditions of the engine.

#### General condition

Periodic inspection and replacement are absolutely necessary to ensure the optimum state of the engine during its service life and prevent any unexpected engine failure.

( ○ : Check and Adjust, ● : Replace)

Inspection item	Daily	Initial 50	Interval (Hr)						Remarks
			500	1,000	1,500	2,000	2,500	3,000	
Cooling system									
Check for water leakage (hose and clamp)	○								
Check coolant level	○								
Check belt tension	○								
Check coolant			○	○	○	○	○	○	
Change coolant			Change every 1,200 hours						
Lubrication system									
Check for oil leakage	○								
Check oil level gauge	○								
Change lubricant <sup>ab</sup>		●	●	●	●	●	●	●	
Replace oil filter cartridge <sup>ab</sup>		●	●	●	●	●	●	●	
Fuel system									
Drain water from water/oil separator	○								
Check fuel line for leakage	○								
Check fuel injection timing									As necessary
Replace fuel filter cartridge			●	●	●	●	●	●	
Check injector									As necessary
Intake/Exhaust system									
Urea filter			Replace every 4,500 hours or 3 years						Whichever occurs first
Engine adjustment									
Check emission condition	○								
Check battery charging level	○								
Check compression pressure									
Adjust intake/exhaust valve clearance			○	○	○	○	○	○	As necessary

a. The change intervals for oil and cartridge may differ by their operating conditions.

b. Change it after initial 50 hours and then every 500 hours.

### Cooling system

#### General information

The coolant plays an important role in the prevention of overheating and freezing of the engine. However, if the engine is used for a long period, the performance of antifreezing and anticorrosion of the coolant degrades. Maintain the condition of the coolant through daily inspections and periodic replacements.

The mixing ratio for the engine coolant is 40 % antifreeze. For the water in the coolant, use clean tap water. Periodically check coolant to maintain the concentration of antifreeze and additives.

#### CAUTION

**The recommended mixing ratio allows coolant to prevent corrosion of the engine efficiently and to maintain the best engine performance for a long period. Using contaminated water or unspecified antifreeze or additives may cause critical faults in the cooler.**

#### Coolant standards

- Amount of antifreeze during winter

Ambient temperature (°C)	Coolant (%)	Antifreeze (%)
Above -10	85	15
-10	80	20
-15	73	27
-20	67	33
-25	60	40
-30	56	44
-40	50	50

#### Coolant level

Coolant capacity ( ℓ )	
LEE00 ~ 15 LEF00/01 LEL00/01	13
LEE17/18/19/20/21/22 LEL04/05/06	17

#### Checking the coolant

#### DANGER

**If the radiator cap is opened to exchange or replenish coolant while the engine is overheated, hot water will spurt out and may cause serious burns. If it is absolutely necessary to open the radiator cap while the engine is overheated, wrap the radiator cap with a cloth and slowly open the cap in two steps until the steam pressure has been released from the inside. After the steam pressure has been completely released, remove the radiator cap.**

1. Check the position of the supplementary tank.
2. Make sure that the engine and radiator are cooled.
3. If the coolant level indicates between the upper limit and the lower limit on the supplementary tank, it means that the coolant volume is normal.
4. If there is insufficient coolant, replenish it.
5. Open the radiator cap and check the condition of the coolant. If the coolant cap is contaminated or insufficient, measure the coolant concentration. If the coolant concentration is outside the specified range, exchange the coolant.

## 4. Regular inspection

### Measurement of coolant concentration

- Special Tools

Figure	Product Number/Name
	60.99901-0038 Coolant test sheet

The coolant concentration can be measured as follows.

- If the engine coolant temperature is within a range of 10 ~ 55°C, drain the coolant and fill half a plastic cup with it.

### CAUTION

When taking out a sample of coolant from the supplementary tank, it is difficult to measure the precise concentration. Always take out sample by opening the drain plug of coolant.

- Soak the test sheet in the coolant and take it out after 3 ~ 5 seconds. Shake the sheet to remove the remaining coolant.
- Wait for about 45 seconds until the test sheet changes its color.

### CAUTION

Measurement time should not exceed 75 seconds. The color changes as time passes.

- Check the color on test sheet.

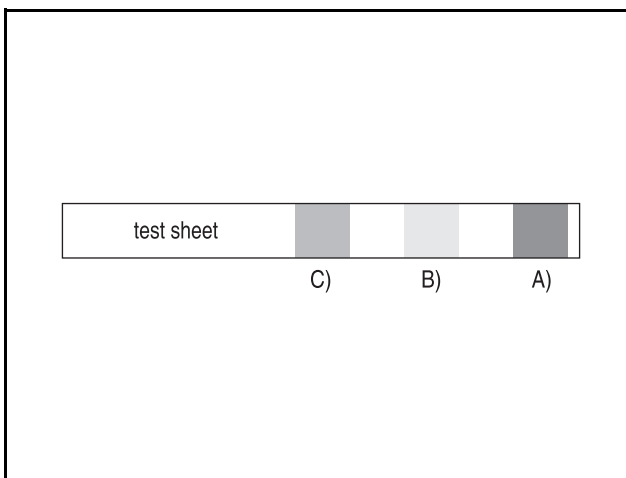

EDL0213002A

- Compare the color of part A on the test sheet to the color of GLYCOL / FREEZEPOINT (End pad) of the standard color table.
- Compare the color of the test sheet (B) to the color of MOLYBDATE (Middle pad) of the standard color table.
- Compare the color of the test sheet (C) to the color of NITRITE of the standard color table.
- Compare and confirm the parts with identical colors on the test sheet and the standard color table.

		% GLYCOL / FREEZEPOINT (°C) (End Pad)								
		25%	33%	40%	50%	60%				
		-12°	-15°	-18°	-21°	-23°	-29°	-34°	-43°	-51°
		SCA Units per litre.								
Row	Color	0.0	0.4	0.7	0.9	1.0	1.1	1.3	1.5	
Row 6	TEST	0.0	0.4	0.6	0.7	0.9	0.9	1.1	1.3	
Row 5		0.0	0.4	0.5	0.5	0.6	0.7	1.0	1.2	
Row 4	SERVICE	0.0	0.3	0.4	0.4	0.6	0.7	0.9	1.1	
Row 3		0.0	0.2	0.3	0.4	0.5	0.6	0.8	1.0	
Row 2		0.0	0.2	0.2	0.2	0.4	0.5	0.7	0.9	
Row 1	PRE CHARGE	0.0	0.1	0.2	0.2	0.3	0.4	0.6	0.9	
Row 0	MOLYBDATE (MIDDLE PAD)	A	B	C	D	E	F	G	H	
		NITRITE								

EDL022154A

- Compare the changed pink color part A of the test sheet with the GLYCOL/FREEZEPOINT (End pad) of the standard color table on top of the container and confirm the concentration. The concentration indication has to be within the color scope of 33~50%.
- The state of additives for anticorrosion is shown on the point where the color of MOLYBDATE (Middle pad) on the standard color table (which is identical with the Middle (B) of the test sheet) is crossed with the color of NITRITE on the standard color table (which is identical with the (C) of the test sheet). It should be maintained at the optimum range, in the green section between 0.3 to 0.8.

### CAUTION

- If the color on the test sheet does not match the color of the standard color table, find a middle color on the standard color table. For example, if the color of (C) of the test sheet matches D and F on the NITRITE of the standard color table, select E.
- To prevent corrosion inside of the engine cooling unit, drain the coolant and replace it with new coolant once a year.



### Replenishment of coolant

If the coolant level of the supplementary tank is below the lower limit, replenish the coolant as follows.

1. Remove the supplementary tank cap.
2. Replenish coolant until its level is between the upper and lower limit of the supplementary tank.
3. Install the supplementary tank cap.

---

### CAUTION

---

**Be careful not let foreign substances flow into the engine when replenishing coolant.**

---

If there is not coolant in the supplementary tank, replenish the coolant as follows.

1. Remove the radiator cap while the engine and radiator are cold.
2. Replenish coolant up to the inlet of the radiator.
3. After starting the engine let the coolant circulate sufficiently and check the coolant level. If there is insufficient coolant, replenish more.
4. Install the supplementary tank cap.
5. Remove the supplementary tank cap.
6. Replenish coolant until its level is between the upper and lower limit of the supplementary tank.

---

### CAUTION

- **If the radiator cap is opened while the engine is hot, hot water will spurt out and may cause serious burns. Open the radiator cap after making sure that the engine has been fully cooled.**
  - **Mark and separately manage the containers for storing coolant from beverage containers for avoiding confusion. See a doctor immediately in case of drinking coolant.**
- 

### Replacement of coolant

---

### DANGER

- **Never open the radiator cap while the engine is overheated. If the radiator cap is opened while the engine is overheated, hot water will spurt out and may cause serious burns. Open the radiator cap after ensuring that the engine has been cooled sufficiently.**
  - **Mark and separately manage the containers for storing coolant from beverage containers to avoid confusion. If coolant is ingested, see a doctor immediately.**
- 

---

### CAUTION

---

**Be careful not to get coolant on any belts or electric apparatus when replacing the coolant.**

---

1. Make sure that engine and radiator are cooled.
2. Place a container in front of the coolant drain plug.
3. Remove the radiator cap.
4. Unplug the coolant drain plug of the radiator and then drain coolant.
5. After completing coolant drain, connect the coolant drain plug again.
6. Drain the coolant from the coolant supplementary tank and cleanse the tank.
7. Fill the radiator inlet with water and install radiator cap.  
Note) Slowly pour coolant in to let the air be discharged from radiator and press the hose connected to it to discharge the air inside.
8. Start the engine to let the cooling fan rotate 2 or 3 times. When the engine is warmed up, increase the engine RPM two or three times.
9. Stop engine and wait until engine is cooled.
10. Remove the radiator drain plug and drain water.
11. Repeat the above mentioned processes from 1 to 8 until the drained water becomes clear.
12. Press the hose connected to the radiator to discharge the air from inside of the radiator and slowly fill the radiator with the coolant at the specified mixing ratio to let the air be discharged from the radiator.

## 4. Regular inspection

---

Note) Use recommended genuine antifreeze.

---

### CAUTION

---

- **Do not mix antifreezes from different manufacturers.**
  - **Do not mix the coolant with different concentrations.**
  - **Do not add antirust which is not recommended by us.**
  - **As insufficient coolant concentration may cause corrosion or freezing, on the other hand, an excessive concentration may degrade the cooling performance. Mix coolant with 40% antifreeze and 3~5% additives (DCA4) to prevent corrosion.**
- 

13. Operate the engine at idle after starting. When cooling fan is running and coolant is circulated, remove radiator cap and replenish coolant through the inlet.
14. Replenish coolant until the cooling fan rotates 3 ~ 5 times.
15. Replenish coolant to the upper limit of the supplementary tank and then install radiator cap.
16. Operate the engine at idle until the cooling fan rotates 2 ~ 3 times.
17. Stop the engine and wait until the engine and the radiator are cooled.
18. After checking the coolant level in the supplementary tank, replenish coolant until the tank level stays between the upper and lower limit without changing.

Note) After replenishing coolant, check the coolant level of the supplementary tank for at least two or three days.

---

### CAUTION

---

**After replenishing coolant, check the coolant level of the supplementary tank for at least two or three days.**

---

---

### WARNING

---

**Discard exchanged coolant according to the regulations set forth by the relevant authorities. Disposing of exchanged coolant into the ground, sewers, drains, rivers, or the sea will cause serious environmental pollution. Violation of regulations regarding discard of engine oil without observing the handling regulations, will be punished.**

---

### Cleaning cooling circuit

If the internal cooling circuit is contaminated by corrosion or foreign materials, the cooling effect can be deteriorated.

Restriction in the cooling circuit can damage the mechanical seal of the water pump. The cooling circuit can be negatively affected by use of improper anti-freeze or anti-corrosion agent or no use of them. If the water pump leaks or the coolant is severely contaminated (cloudy. Its contamination level can be identified by its discoloration: brown, gray and black) within a short period of time of engine use, clean the cooling system as follows before removing the water pump:

1. Drain coolant.
2. To clean the cooling circuit quickly, remove the water temperature controller.
3. Replenish the cooling circuit with water mixed with 1.5% of cleaning agent (Henkel P3T5175).
4. Apply load to the engine. When the coolant temperature rises to 60°C, run the engine for approx. 15 minutes.
5. Drain the cleaning agent.
6. Repeat the step 3 to step 4.
7. Add hot water into the cooling circuit.
8. While idling the engine for approx. 30 minutes, check the drain plug and coolant line for leakage. If coolant is insufficient, add more.

---

### CAUTION

---

**Clean the cooling circuit with a cleaning agent regularly.**

---

### Lubrication system

#### General information

Engine oil lubricates, cools, seals, prevents corrosion, and cleans engines, enhancing engine performance and extending the engine's lifetime. If a vehicle is continuously driven while engine oil is insufficient, the moving parts of the engine may get stuck, causing engine faults.

Engine oil should be checked through the oil level gauge and replenished if required. Oil level should be checked while the engine is stopped. To check the oil level, turn off the engine while it is running and wait for 5 ~10 minutes to allow the engine oil to flow back into the oil pan. The engine oil level should indicate between the upper limit and the lower limit of the oil level gauge.

Engine oil should be periodically replaced based on the regular inspection table and the oil filter and the cartridge should be replaced as the engine oil is replaced.

## 4. Regular inspection

### Engine oil specifications

Use only specified engine oil according to the environment and condition of the area.

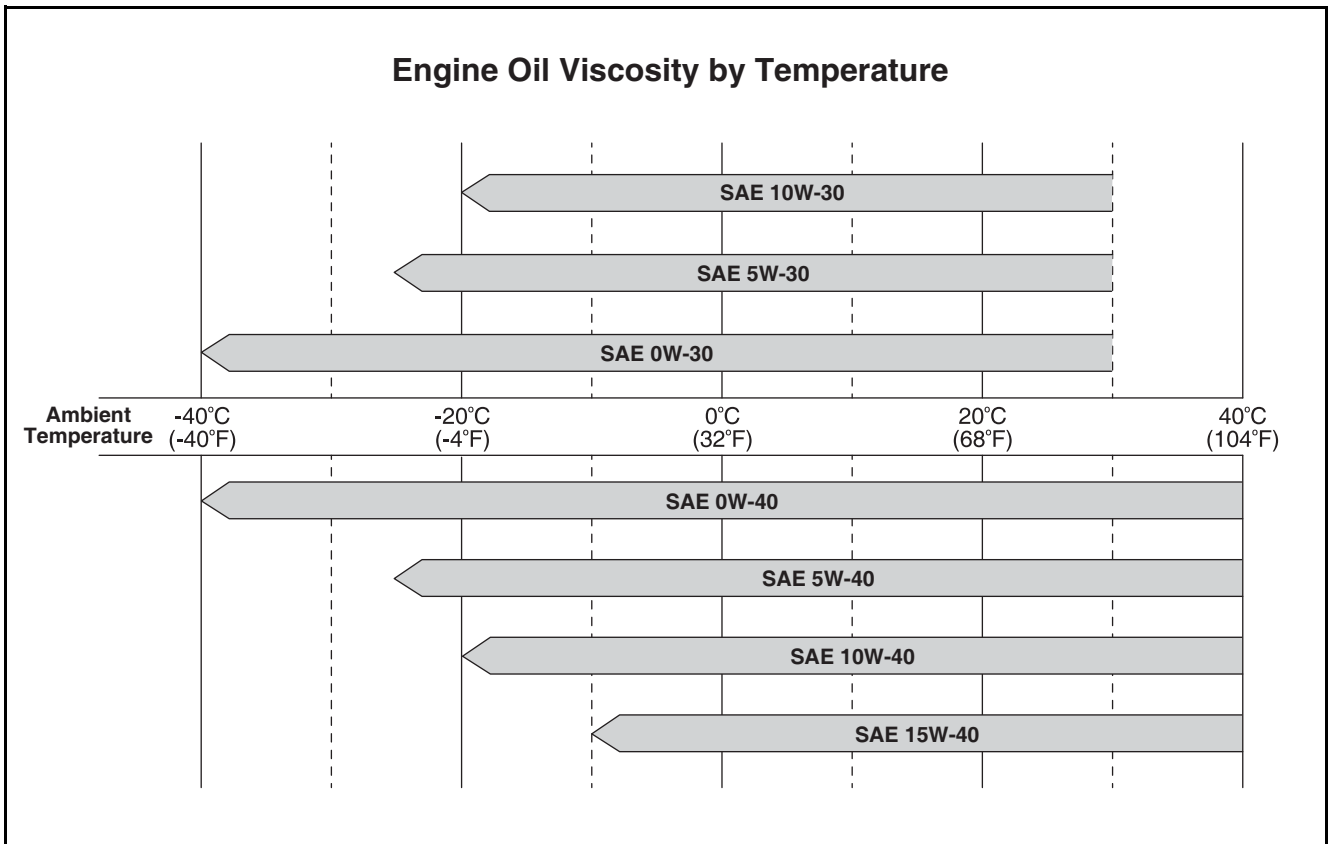

EDL06200023

Make sure to use proper engine oil according to the following recommendation.

Engine model	SAE classification	Oil grade
DL06P	SAE 10W40	ACEA-E9 (API CJ-4)

Note) Make sure to use the recommended genuine oil.

## 4. Regular inspection

### Engine oil capacity

Add a proper amount of engine oil to the engine according to the following recommended capacity:

Engine model and Product code	Engine oil capacity ( ℓ )		
	Oil pan		Total <sup>a</sup>
	Maximum	Minimum	
DL06-LEE00	27	15	29
DL06-LEE01	27		29
DL06-LEE02	27		29
DL06-LEE03	27		29
DL06-LEE04	27		29
DL06-LEE05	27		29
DL06-LEE06	22	16	24
DL06-LEE07	22	16	24
DL06-LEE08	27	15	29
DL06-LEE09	27		29
DL06-LEE10	27		29
DL06-LEE11	27		29
DL06-LEE12	27		29
DL06-LEE13	27		29
DL06-LEE14	22	16	24
DL06-LEE15	22	16	24
DL06-LEE17	27	15	29
DL06-LEE18	27	15	29
DL06-LEE19	27	15	29
DL06-LEE20	27	15	29
DL06-LEE21	27	15	29
DL06-LEE22	22	16	24
DL06-LEF00	27	15	29
DL06-LEF01	27		29
DL06-LEL00	27	20	29
DL06-LEL01	27	20	29
DL06-LEL04	24.5	17.5	26.5
DL06-LEL05	24.5	17.5	26.5
DL06-LEL06	24.5	17.5	26.5

a. Including 2.0 liters in engine

### Checking engine oil

1. Move the vehicle onto level ground to maintain the engine horizontally.
2. Start the engine. When the engine temperature increases to a normal operating temperature, stop the engine.
3. Wait for 5 - 10 minutes.
4. Pull out the dipstick.
5. Clean the level indicating section of the dipstick with a clean cloth.

### CAUTION

**If wiping the dipstick with a dirty cloth, foreign materials may enter the engine, causing engine failure.**

6. Fit the dipstick back into the engine.
7. Pull out the dipstick to check the oil level and oil condition.

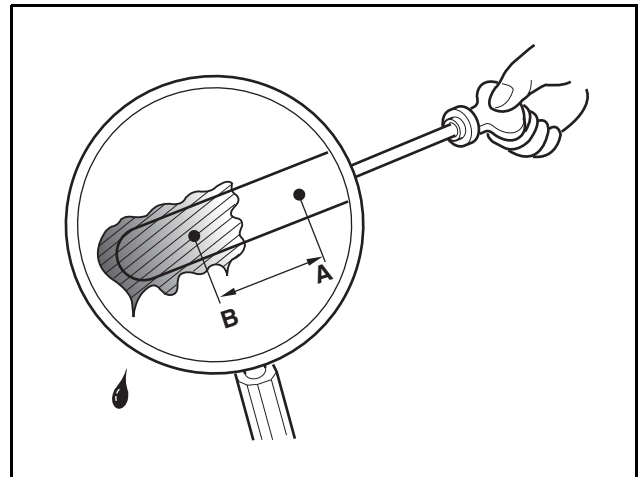

EDL022152A

- 1) Check if the oil level is between the upper limit (A) and lower limit (B) on the dipstick.
- 2) If the oil level is below the lower limit (B) or engine oil is not on the dipstick at all, add engine oil.

### CAUTION

**Do not add engine oil over the upper limit mark on the dipstick. If the engine oil level is over the upper limit, the engine can be damaged.**

- 3) Check the viscosity and condition of engine oil. When necessary, change it.

## 4. Regular inspection

### Adding engine oil

---

#### CAUTION

---

**When working on the vehicle with the oil filler cap removed, never let foreign materials enter the engine.**

---

1. Remove the oil filler cap from the top of the engine.
  2. Replenish the engine with the recommended genuine engine oil.
  - 1) Add the recommended genuine oil into the engine little by little in several steps.
  - 2) Wait for approx. 1 to 2 minutes before checking the engine oil.
  - 3) Check if the oil level is between the upper limit and lower limit on the dipstick.
  - 4) Repeat the above steps until the engine oil level becomes proper.
- 

#### CAUTION

---

- **When adding engine oil, make sure no foreign material enter the engine.**
  - **If adding engine oil over the upper limit, it can lead to engine failure. If the engine oil level is over the upper limit, drain engine oil until the level is between the upper and lower limit marks on the dipstick.**
  - **Never mix engine oil with any unspecified additive.**
- 

3. After adding engine oil, fit the oil filler cap.

### Changing engine oil

1. Drain engine oil.
  - 1) Place a container under the engine to collect drained engine oil.
  - 2) Remove the drain plug to drain engine oil.
  - 3) Remove the oil filler cap.
2. Replace the oil filter.

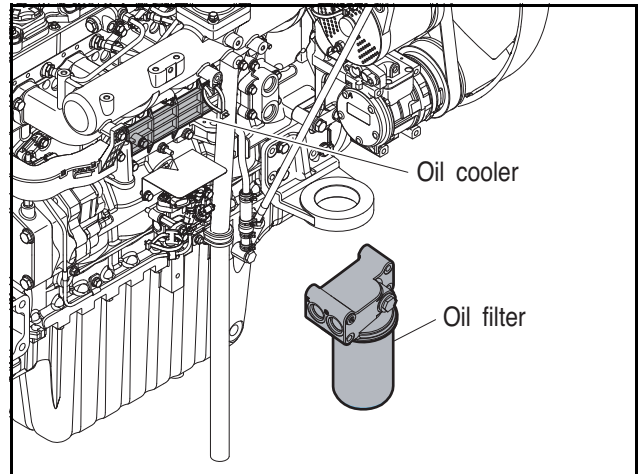

EK4OM041-E

- 1) Remove the oil filter using its service wrench.
  - 2) Wipe the head and cartridge contact area of the oil filter clean.
  - 3) Seat the cartridge of the oil filter properly.
  - 4) Apply a small amount of oil to the O-ring section of the cartridge.
  - 5) Fit a new oil filter loosely by screwing it with a hand.
  - 6) Remove the oil filter using its service wrench.
- 

#### CAUTION

---

- **When replacing the cartridge of the oil filter, make sure to use the specified genuine one.**
  - **The oil filter should be installed to the engine without oil in it. Never fill the new oil filter with oil drained from the used oil filter.**
-

3. Add engine oil.

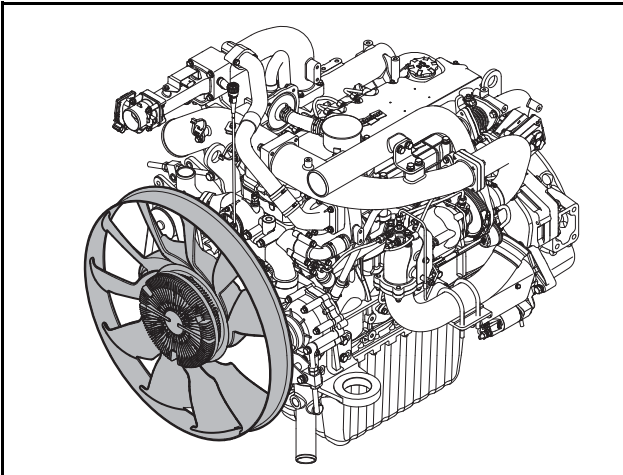

EK4OM012

- 1) Install the drain plug.
- 2) Add engine oil while checking the oil level through the oil filler hole.

---

### CAUTION

**Never let any foreign material enter the system while adding oil.**

---

- 3) Confirm that the needle on the oil level gauge is on the upper limit indication.
4. Perform the final inspection after performing the specified steps.
  - 1) Idle the engine for a few minutes to let oil circulate in the engine lubrication circuit.
  - 2) Stop the engine and wait for 10 minutes.
  - 3) Check the oil level and add more oil as necessary.

---

### CAUTION

**If adding engine oil over the upper limit, it can lead to engine failure. If the engine oil level is over the upper limit, drain engine oil until the level is between the upper and lower limit marks on the dipstick.**

---

## 4. Regular inspection

### Fuel system

#### General information

Fuel quality is an important factors in satisfy standards for engine performance, engine lifetime, and emissions. Doosan engines are designed to use diesel fuel available in the area where the engines are sold.

#### CAUTION

- **Use clean, specified, and qualified fuel only. Using irregular or unspecified fuel may cause critical damage and faults to the engine.**
- **Inject fuel while the engine is stopped.**

#### Fuel standards

To maintain the optimum engine performance, refer to the following recommended fuel table to select the appropriate fuel.

- Ultra Low Sulfur Diesel

Fuel Ingredients		Standard
Specific Gravity	(kg/lit)	0.820 ~ 0.845
Fire Point	(°C)	Above 40
Viscosity (40°C)	(cSt)	1.9 ~ 5.5
Sulfur Content	(wtppm)	Below 15
Cloud Point	(°C)	-
Pour Point	(°C)	Below -17.5
Low temperature filter clogging point	(°C)	Below -16
Color (ASTM)		Below 2.5
Residual carbon (10%) Vapor/residual fraction (wt)	(%)	Below 0.15
Total acid value	(mg KOH/g)	Below 0.40
Back plate corrosion rate (100°C, 3 hours)		Below 1
Ash Content	(mass %)	Below 0.01
Moisture and Precipitation	(vol. %)	Below 0.02
Cetane Index		Above 45
Distillation Test Temperature	50 % Distillation Point	-
	90 % Distillation Point	Below 360

Note) High sulphur content in diesel fuel Doosan diesel engines can be operated with fuels whose sulphur content is max. 15wtppm.

#### Fuel filter

It is used to remove water and foreign materials from fuel in order to send clean fuel to the fuel injection pump.

#### CAUTION

- **Make sure to check the fuel filter and drain water from it periodically. Otherwise, water may enter the engine fuel system, causing a serious problem to the fuel injection pump, fuel injection pipe, common rail, injector, etc. Also, it can deteriorate or damage the fuel filter.**
- **When draining water from the fuel filter, fuel may be drained as well. Fuel is highly flammable. Keep a lit cigarette or flame away from the engine during draining water from the filter.**
- **Use the specified clean quality fuel only. If using fuel other than the specified one, more water can be accumulated in the fuel filter.**
- **If water is not drained from the fuel filter when the fuel filter warning lamp is turned on, water may enter the fuel system, causing engine stall.**
- **A new fuel filter should be installed without fuel in it. Never add fuel in the used fuel filter or fuel tank to a new fuel filter.**

#### Air bleeding in the fuel circuit

To bleed the fuel line, loosen the fuel feed pipe between the secondary fuel filter and high-pressure fuel pump slightly and operate the priming pump of the primary fuel filter manually until air bubbles are not visible any more.



### Intake/Exhaust system

#### General information

The air filter is used to remove dust and foreign materials from the air in order to supply clean air into the engine. The air filter should be checked, cleaned and replaced regularly since it directly affects the engine service life, emissions and engine power.

#### CAUTION

- Never run the engine with the air filter removed.
- Use the specified air filter only. If using a fake or recycled one, a serious problem may occur to the system.
- If foreign materials are led into the engine, they can wear the interior of the engine.
- When replacing the air filter, be careful not to damage any electric part and let foreign materials enter the engine.
- If the air filter is damaged, replace it with a new one immediately.
- When installing the air filter, make sure that no dust is entered the system.
- If the element of the air filter is deformed, damaged or cracked, replace it with a new one.
- Clean and replace the element periodically.

#### Cleaning of air filter

1. Clean the air filter.

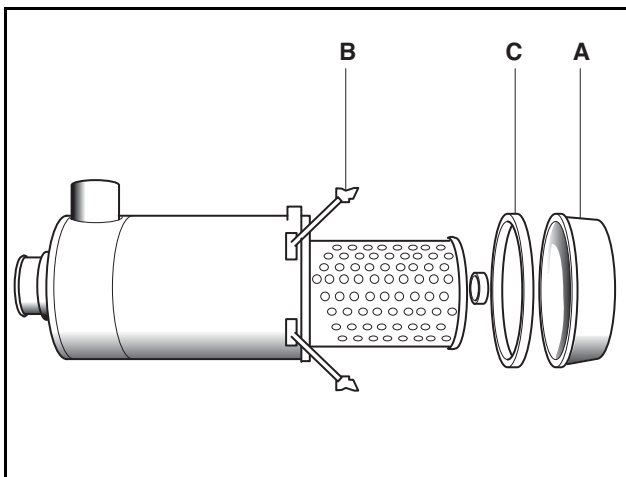

EK00021A

- 1) Clean the canister (A) regularly.

#### CAUTION

Never let the canister filled with dust more than its half.

- 2) The canister can be removed by undoing its two clamps (B).
- 3) Remove the cover (C) and empty the canister.
- 4) Install the cover and canister correctly with care.
- 5) There is a groove around the cover for its correct alignment with the protrusion of the dust canister.
- 6) Check the "TOP" mark on the air filter cylinder so that the filter is installed horizontally.

#### Cleaning of the air filter element

Clean the air filter element by using the most suitable method for your work environment among the three methods stated below.

1. Use compressed air to clean the air filter element.

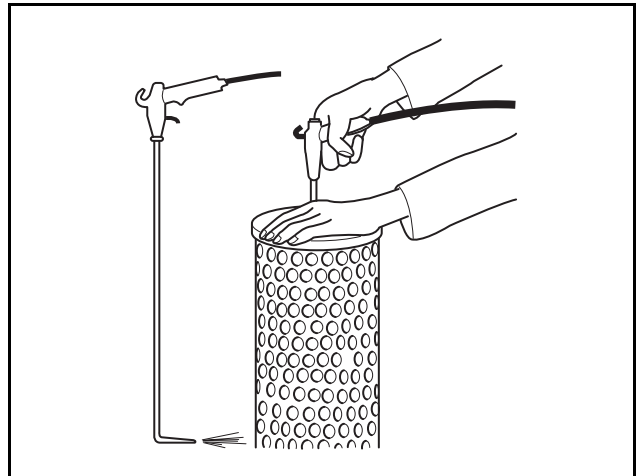

EDL022155A

- 1) To clean, let sufficient compressed air reach the inside bottom of the element at 90° direction with an air gun.
- 2) Move air gun up and down the element to blow air from inside to outside until no more dust is coming out from the element.
- 3) Do not use compressed air pressure exceeding 5 bars.

#### DANGER

Always wear protective goggles before starting work.

Otherwise, dust or foreign substances from the element may get in your eyes and cause injuries.

## 4. Regular inspection

2. Clean the element by washing it.

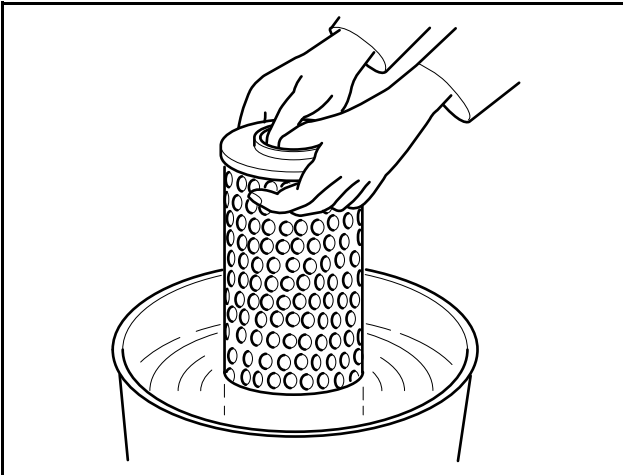

EDL022156A

- 1) Before washing the element, clean the element by using compressed air as described above.
- 2) Soak the element in the warm cleaning solvent for 10 minutes and then shake it back and forth for about 5 minutes.
- 3) Rinse the element with clean water, drain the water, and then dry it at room temperature. Fully dry the element before reassembling it to the engine.

### **⚠ CAUTION**

**Never use steam spray, gasoline, alkali or hot cleansing solution to cleansing the element.**

3. In an emergency, temporarily clean the element by using the following method.
  - 1) Tap the end plate of the element with the thumb to clean it temporarily.

### **⚠ CAUTION**

- **This method should only be used in an emergency when cleaning of element is necessary and no compressed air or cleansing solution is available.**
- **Under no circumstances should the surface of the element be hit or beaten with a hard object to shake the dust off.**

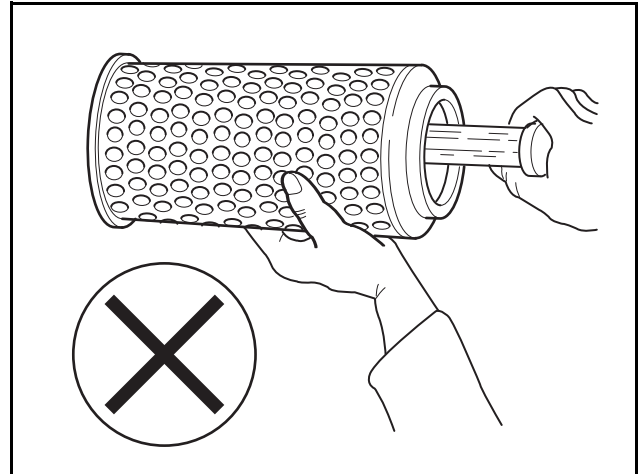

EDL022157A

- Note) Before reassembling the element, make sure that the filter paper is not wrinkled, the state of rubber sealing is good, and there is no deformed part in the element.
- Note) Under any circumstances, do not reuse damaged elements. When in doubt, replace the element with a new one.

### **Replacement of the air filter element**

1. Replace the air filter element.

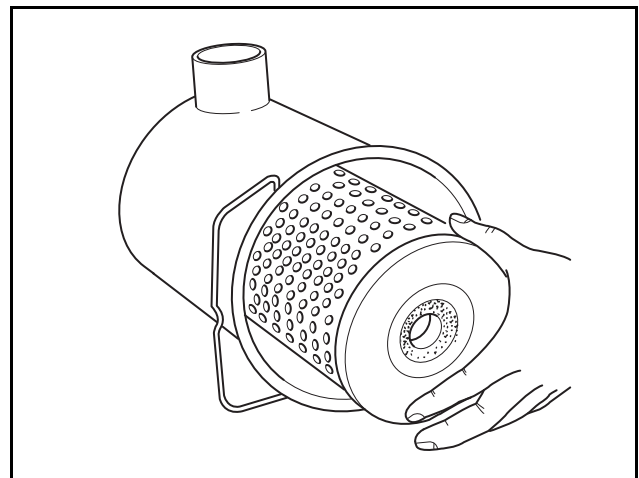

EK00025A

- 1) Unscrew the hex. nut and remove the dirty element. Clean it or replace it with a new one.
- 2) Wipe the inside of the filter housing and seal ring contact area of the element with a wet cloth cleanly.

### **⚠ CAUTION**

**Make sure that no dust is entered the air filter through its tip.**

### Turbocharger

1. The turbocharger is a maintenance-free part.
2. When changing engine oil, make sure to check the oil pipe for leakage and restriction as well.
3. The air filter should be carefully maintained so that no foreign material is led into it. Compressed air and exhaust pipe of the turbocharger should be inspected periodically. If air leak occurs, it should be repaired immediately as it can result in overheating of the engine.
4. When running the engine in a work space mixed with dust or oil, the impeller needs to be cleaned frequently. Remove the impeller casing (CAUTION: Be careful not to bend it.) and clean it only with non-acid solvent solution. If necessary, use a plastic scraper. If the impeller is severely contaminated, soak it in solvent and use a bristle brush to clean it thoroughly. In this cleaning process, soak the impeller only and support the turbocharger with the bearing housing, not with the impeller.

## 4. Regular inspection

### Cylinder block/head

#### Valve clearance

Adjust the valve clearance under the following conditions:

- When disassembling the engine or cylinder head,
- When loud noise is heard from the valve connection,
- When the fuel injection system is intact but the engine operates abnormally.

#### Valve clearance adjustment procedure

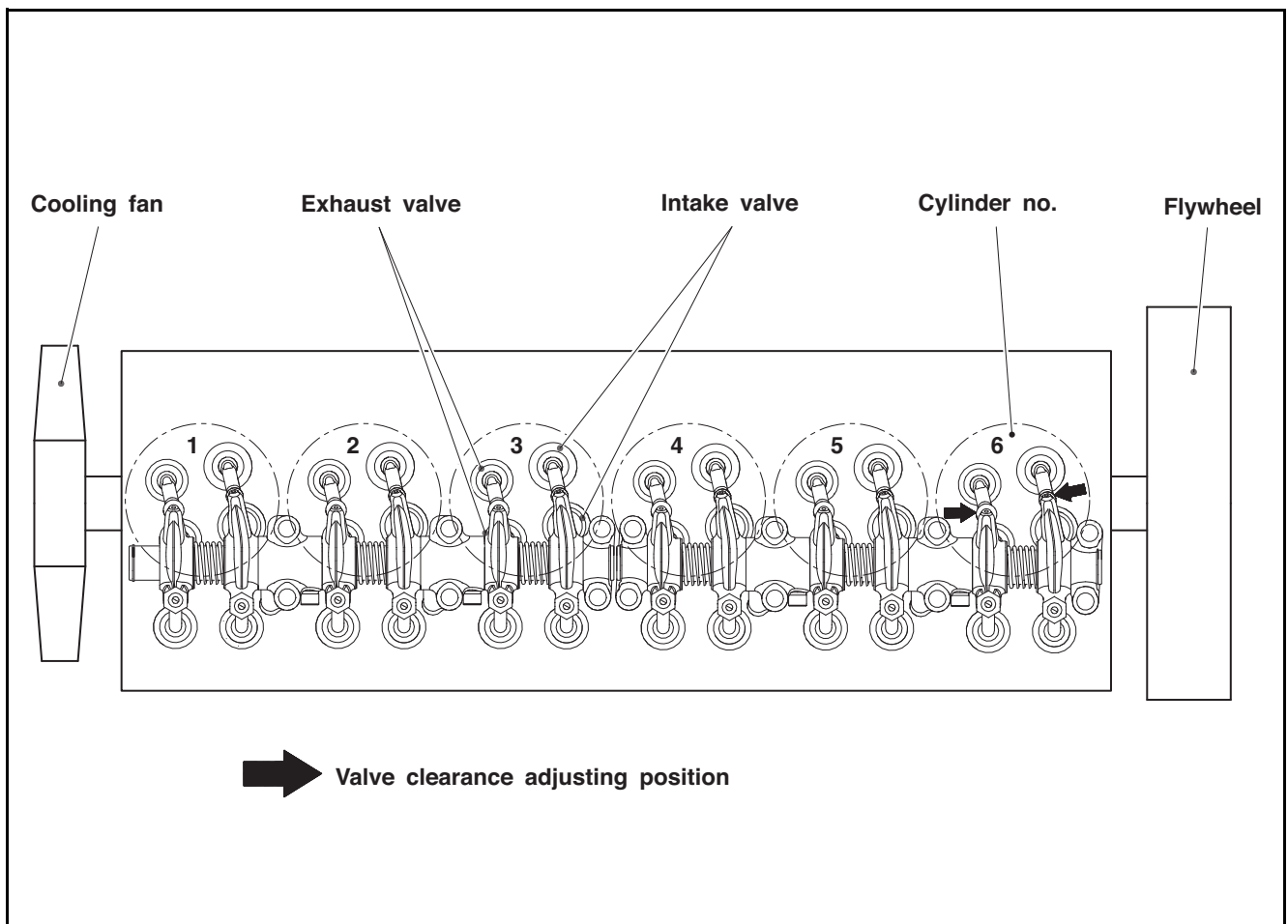

EK4OM014-E

## 4. Regular inspection

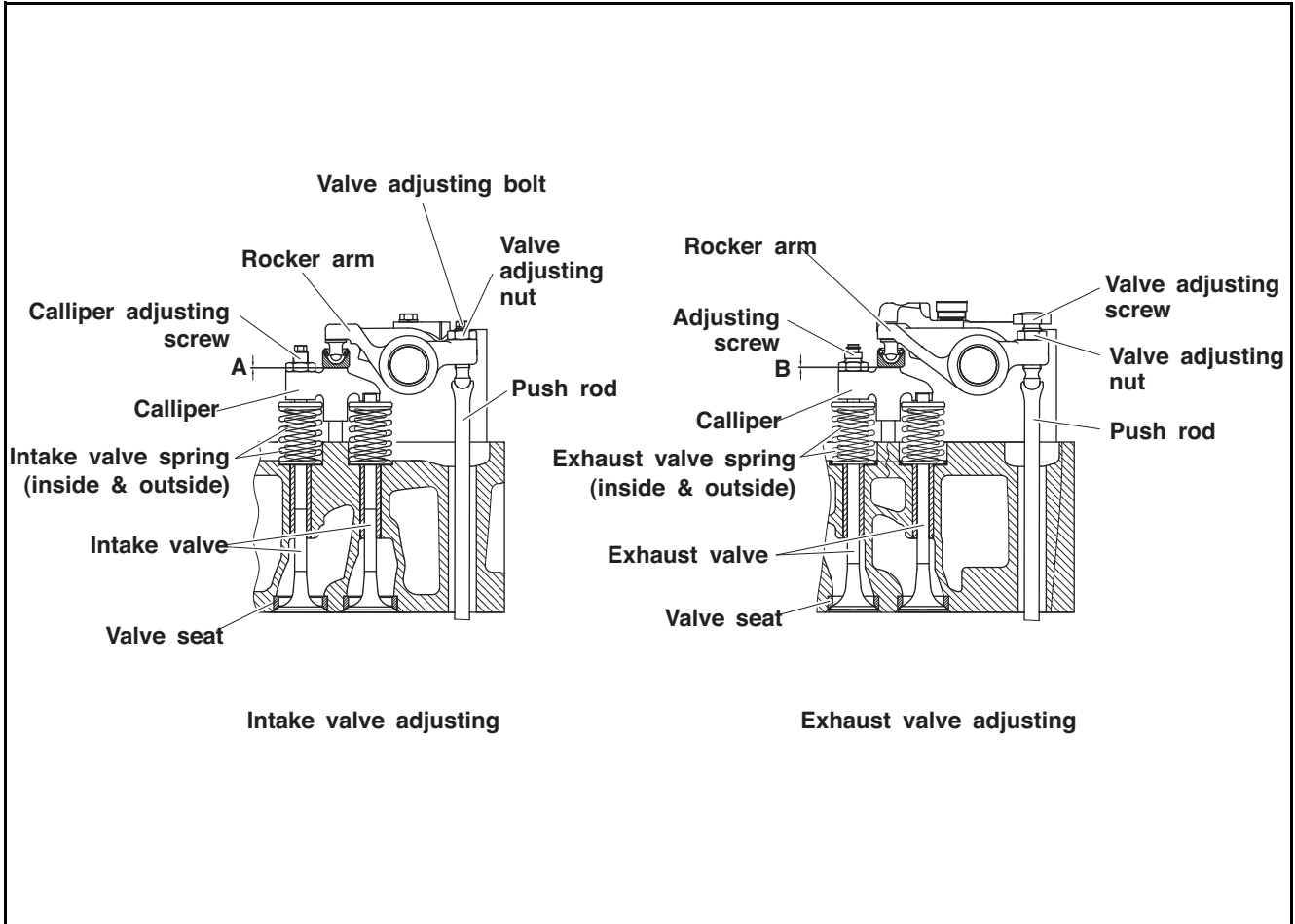

EJ9OM089-E

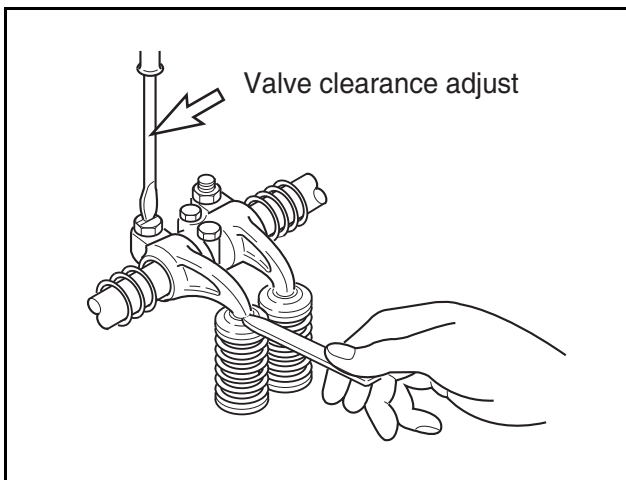

EDL06170002

- Torque:  $4.4 \pm 0.45$  kg.m

## 4. Regular inspection

### [Method 1]

- Turn the crankshaft to set the piston of the cylinder No. 1 to the TDC on the compression stroke.

Note) The cylinder No. 1 can be identified by the cooling fan.

Note) When the cylinder No. 1 is at the TDC on the compression stroke, valve overlap is occurred at the cylinder No. 6.

- Unscrew the rocker arm mounting nut at the cylinder No. 1.
- Adjust the cylinder clearance with its adjusting nut. Then, tighten the mounting nut.

Specified value		Measurement tolerance	
Intake valve	Exhaust valve	Intake valve	Exhaust valve
0.3 mm	0.4 mm	±0.05 mm	

- Turn the crankshaft to adjust the valve clearance for each cylinder at the TDC on the compression stroke.
- According to the cylinder in the valve overlap period, adjust the valve clearance for the corresponding cylinder at the TDC on the compression stroke as follows:

Cylinder No. in valve overlap period					
1	5	3	6	2	4
6	2	4	1	5	3
Cylinder No. for valve adjustment					

### [Method 2]

- Turn the crankshaft to set the valves of the cylinder No. 6 overlapped.

Note) When the cylinder No. 1 is at the TDC on the compression stroke, valve overlap is occurred at the cylinder No. 6.

Note) The cylinder No. 1 can be identified by the cooling fan.

- Adjust the valve clearance marked with ' • ' in the table.
- Rotate the engine for 1 turn (360°) in the engine rotating direction to set the valves for the cylinder No. 1 overlapped.

Note) When the cylinder No. 6 is at the TDC on the compression stroke, valve overlap is occurred at the cylinder No. 1.

- Adjust the valve clearance marked with ' ◦ ' in the table.
- Check the valve clearance again, and adjust it as necessary.

(E: Exhaust valve, I: Intake valve)

Cylinder No.	1		2		3		4		5		6	
Valve	E	I	E	I	E	I	E	I	E	I	E	I
No. 1 TDC	•	•			•			•	•	•		
Turn 360°			◦	◦		◦	◦				◦	◦

### Electric system

#### Battery

1. Check the battery for electrolyte leakage from its crack. If the battery is in a poor condition, replace it.
2. Check the electrolyte amount. If it is insufficient, add distilled water to the battery.
3. Measure the specific gravity of the electrolyte. If the measurement is below the specification (1.12 ~ 1.28), replenish the battery.

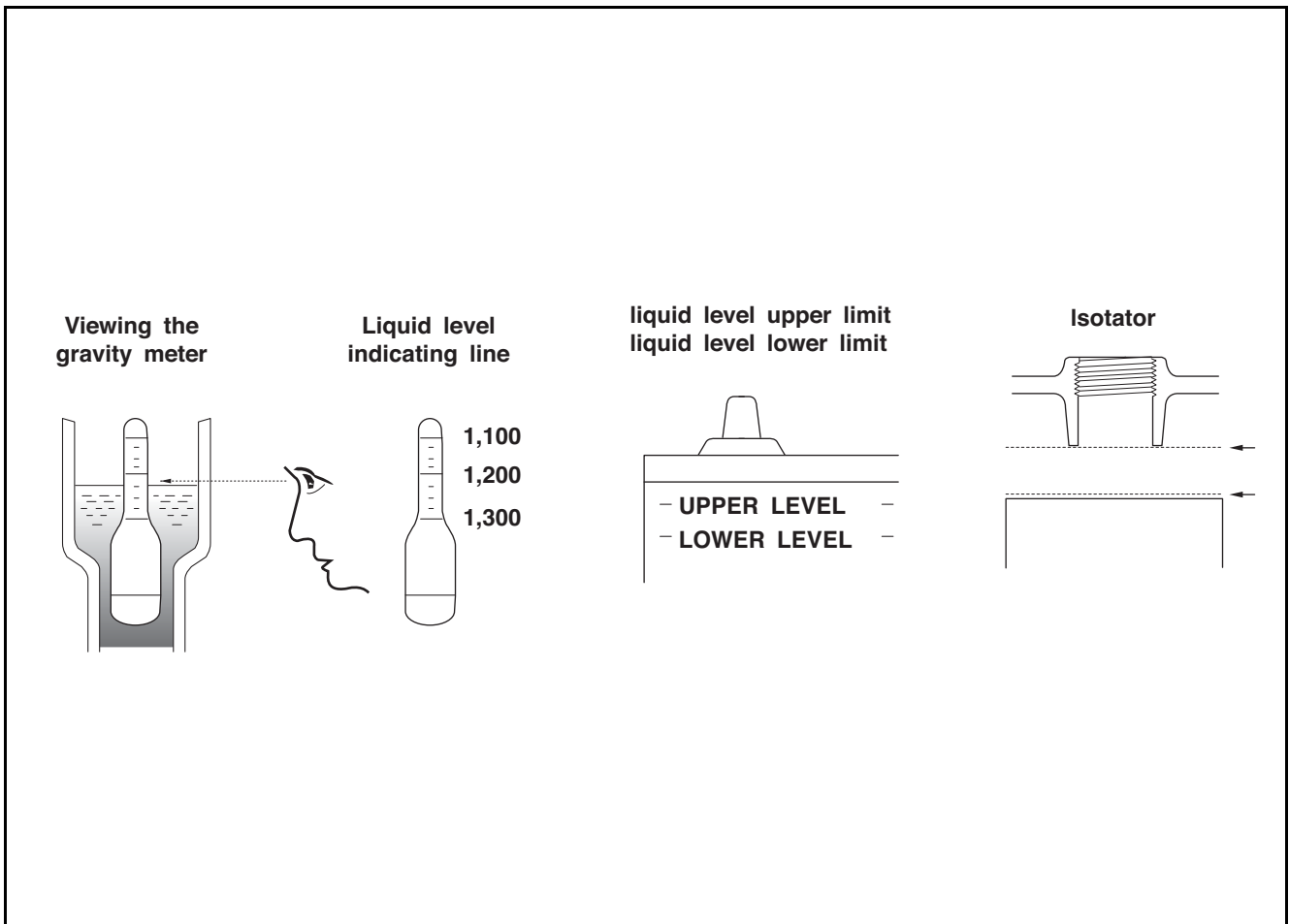

EFM10071-E

## 4. Regular inspection

### Others/Driving system

#### Belt tension

The belt's tension should be checked daily and adjusted as necessary.

1. Inspection condition
  - 1) Check the belt for crack, oil residue, deformation by heat and wear.
  2. Test with hands

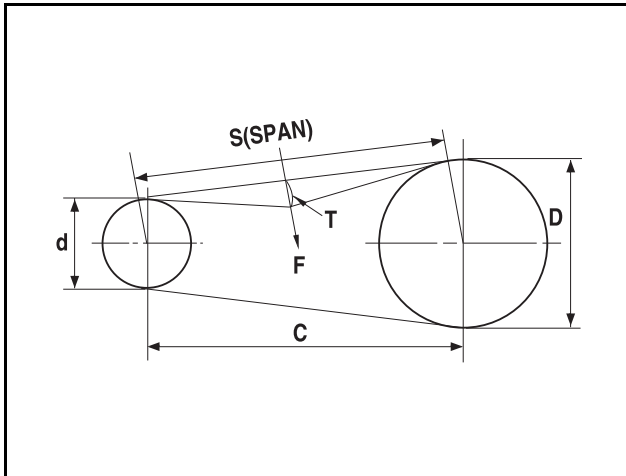

EDL022140A

- 1) The tension of the belt can be inspected by checking the amount of deflection of the belt when applying the specified force (F) to it.
- 2) Adjust the belt so that the deflection (T) equals to  $0.015 \times S$  (1.5 mm for 100 mm).

Note) T: deflection amount, S: distance

$$3) *S = \sqrt{C^2 + \frac{(D-d)^2}{2}}$$

Note) C : distance between shafts (mm), D: large pulley diameter (mm), d: small pulley diameter (mm)

3. Tension measurement

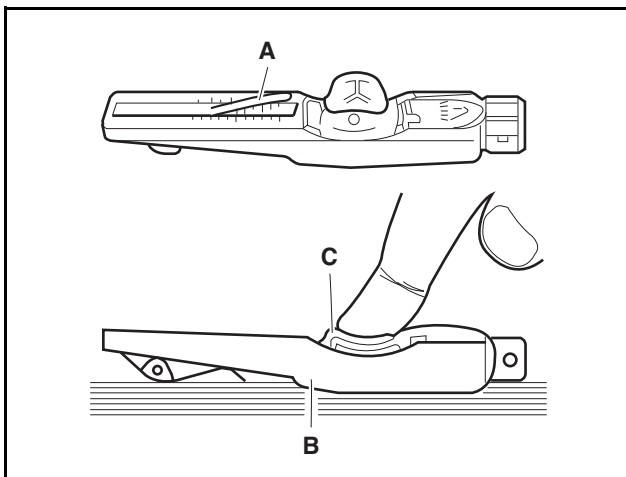

EDL022141A

- 1) Insert the belt to the protrusion (A) of the tension measuring instrument.
  - Set the measuring instrument between the pulleys and set its contact end (B) to push the belt.
  - Press the pad (C) until unscrewing sound of the spring is heard. This force pushes the tension measuring instrument upwards.
  - If there is still tension left on the belt after removing the pad (C), the measurement result is not accurate.
- 2) Tension measurement
  - Read the value where the top of the protrusion (A) of the tension measuring instrument is aligned with the scale.
  - Before reading the value, make sure that the needle of the measuring instrument is returned back to the original position.
4. The belt tension is as follows:

Number of belt folds (PK type)	Tension (kgf)
3	20 - 27
4	27 - 36
5	34 - 45
6	41 - 57
7	48 - 66
8	59 - 73

5. The belt consists of the following components:

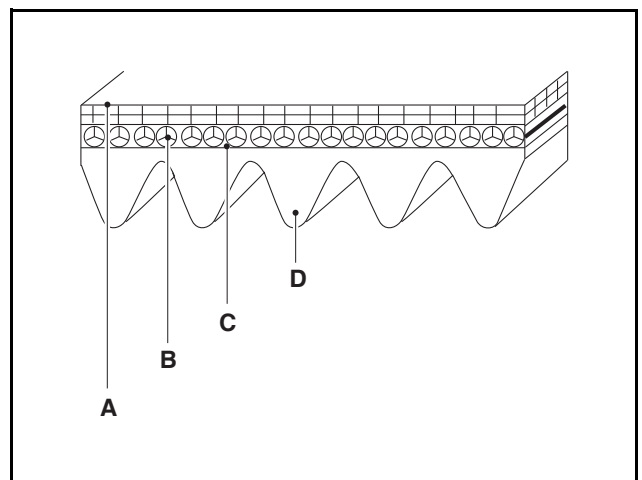

EDL022142A

- 1) The belt consists of the cover layer (A), cord (B), adhesive rubber (C) and belt reinforcement rubber (D).



# 5. About the engine

Marking system of units .....	91
Unit conversion methods .....	91
Tightening torque .....	92
Tightening torque of major parts .....	92
Tightening torque for general bolts .....	94
Tightening torque of plug screw .....	95
Hollow screw (4-Hole) tightening torque .....	95
Engine disassembly .....	96
Engine disassembly procedure .....	96
Engine assembly .....	109
Engine assembly sequence .....	109



### Marking system of units

#### Unit conversion methods

The following methods show how to convert SI units to US units and vice versa.

- To convert an SI unit to a US unit, multiply a SI unit with the number in the following table.

Note) (SI Unit) X (Number) = (US Unit)

Note) 1mm X 0.03937 = 0.03937 in

- To convert a US unit to an SI unit, divide the US unit by the number in the following table.

Note) (US Unit) ÷ (Number) = (SI Unit)

Note) 1 in ÷ 0.03937 = 25.4 mm

Item	Number	SI Unit	US Unit
Length	0.03937	mm	in
	3.28084	m	ft
	1.093613	m	yd
	0.621371	km	mile
Area	0.00155	mm <sup>2</sup>	in <sup>2</sup>
	0.1550	cm <sup>2</sup>	in <sup>2</sup>
	10.76391	m <sup>2</sup>	ft <sup>2</sup>
	1.19599	m <sup>2</sup>	yd <sup>2</sup>
Weight	2.204623	kg	lb
	0.001	kg	t (ton)
Volume	0.061024	cc	in <sup>3</sup>
	0.061024	ml	in <sup>3</sup>
	0.061024	cm <sup>3</sup>	in <sup>3</sup>
	61.023744	L	in <sup>3</sup>
	0.264172	L	gal
Force <sup>a</sup>	2.204622	kgf	lbf
	0.2248089	N	lbf
Acceleration	3.28084	m/s <sup>2</sup>	ft/s <sup>2</sup>
	39.37008	m/s <sup>2</sup>	in/s <sup>2</sup>
Torque <sup>b</sup>	7.233014	kg·m	lbf·in
	86.79619	kg·m	lbf·in
	0.7375621	N·m	lbf·ft
	8.850748	N·m	lbf·in

Item	Number	SI Unit	US Unit
Power	1.340483	kw	Hp
Pressure	0.01	kPa	bar
	7.500615	kPa	mmHg
	20.88543	kPa	lb/ft <sup>2</sup>
	14.2233	psi	kg/cm <sup>2</sup>
Electric Power	1.3596	kw	PS
	0.98635	ps	hp
Fuel Consumption	0.00162	g/kwh	lb/psh
Energy	0.000947817	J	BTU
	0.7375621	J	lbf·ft
	0.0002777778	J	Wh
Luminous Flux	0.09290304	lm/m <sup>2</sup>	lm/ft <sup>2</sup>
Speed	0.6213712	km/h	mph
Temperature	°C	°C	°F

- $9.806 \times (\text{kg}\cdot\text{f}) = (\text{N})$
- $9.806 \times (\text{kgf}\cdot\text{m}) = (\text{N}\cdot\text{m})$
- $\{(9/5) \times (^\circ\text{C}) + 32\} = (^\circ\text{F})$   
 $\{(^\circ\text{F}) - 32\} \times (5/9) = (^\circ\text{C})$

## 5. About the engine

### Tightening torque

#### Tightening torque of major parts

Major parts	Screw (Diameter x pitch)	Tightening torque (kgf·m)
Cylinder block bearing cap bolt	M16 x 2.0	6 kg·m + 90°
Oil spray nozzle	M10 x 1.25	2.1 +0.5 kg·m
Flywheel housing mounting bolt	M12 x 1.5	11.2 +1.0 kg·m
Crank pulley mounting bolt	M14 x 1.5	20 ±2.0 kg·m
Shock absorber	M10 x 1.5	6.2 +0.5 kg·m
Flywheel mounting bolt	M14 x 1.5	20 +2.0 kg·m
Connecting rod cap bolt	M12 x 1.5	3 kg·m (±0.15) + 60° (±30°)
Cylinder head bolt	M13 x 1.5	5 kg·m + 90° + 90° + 90°
Cylinder head cover bolt	M8	2.2 +0.5 kg·m
Injector cable mounting nut	M4	0.15 +0.01 kg·m
Rocker arm bracket mounting bolt	M8 x 1.25	3.7 +0.5 kg·m
Rocker arm adjusting nut	M10 x 1.0	4.4 +0.45 kg·m
Oil pump cover	M8	2.2 +0.5 kg·m
Oil pump mounting bolt	M10 x 1.5	4.4 +0.5 kg·m
Oil cooler mounting bolt	M8	2.2 +0.5 kg·m
Oil pan mounting bolt	M8	2.2 +0.5 kg·m
Oil drain plug	M30 x 1.5	10 +1.0 kg·m
Exhaust manifold mounting bolt	M8	2.8 ±0.28 kg·m → 90° Loose → 3.5 kg·m
Intake manifold mounting bolt	M10 x 1.5	4.4 +0.5 kg·m
Start motor	M12 x 1.5	8.0 +1.0 kg·m
Coolant temperature sensor	M12 x 1.5	2.2 kg·m (Max. 2.5 kg·m)
Engine mounting bracket	M10 x 1.5	6.2 +0.5 kg·m
Fuel high-pressure pump gear nut (CP pump)	M18 x 1.5	11 +0.5 kg·m
Fuel injector mounting bracket bolt	M8	3.1 kg·m
Fuel high-pressure pump mounting bolt (cylinder block)	M8	4.4 +0.5 kg·m
Fuel high-pressure connector nut	M22 x 1.5	5 +0.5 kg·m
Common rail mounting bolt	M8	2.2 +0.5 kg·m

## 5. About the engine

---

Major parts	Screw (Diameter x pitch)	Tightening torque (kgf·m)
Fuel high-pressure pipe - high-pressure fuel connector	M14 x 1.5	2.8 +0.5 kg·m
Fuel high-pressure pipe - common rail	M14 x 1.5	2.5 +0.5 kg·m
Fuel high-pressure pipe - fuel high-pressure pump	M14 x 1.5	2.1 +0.5 kg·m
Fuel filter mounting bolt	M10	4.4 +0.5 kg·m

## 5. About the engine

### Tightening torque for general bolts

Keep the following torque values for bolts not specified in the Tightening Torque for Major Parts table.

#### 1. Tightening torque for general bolts

Size Diameter x pitch (mm)	Hardness										
	3.6	4.6	4.8	5.6	5.8	6.6	6.8	6.9	8.8	10.9	12.9
	(4A)	(4D)	(4S)	(5D)	(5S)	(6D)	(6S)	(6G)	(8G)	(10K)	(12K)
	Elastic limit (kg/mm <sup>2</sup> )										
	20	24	32	30	40	36	46	54	64	90	106
Tightening torque (kg·m)											
M5	0.15	0.16	0.25	0.22	0.31	0.28	0.43	0.48	0.5	0.75	0.9
M6	0.28	0.30	0.45	0.4	0.55	0.47	0.77	0.85	0.9	1.25	0.5
M7	0.43	0.46	0.7	0.63	0.83	0.78	1.2	1.3	1.4	1.95	2.35
M8	0.7	0.75	1.1	1	1.4	1.25	1.9	2.1	2.2	3.1	3.8
M8×1	0.73	0.8	1.2	1.1	1.5	1.34	2.1	2.3	2.4	3.35	4.1
M10	1.35	1.4	2.2	1.9	2.7	2.35	3.7	4.2	4.4	6.2	7.4
M10×1	1.5	1.6	2.5	2.1	3.1	2.8	4.3	4.9	5	7	8.4
M12	2.4	2.5	3.7	3.3	4.7	4.2	6.3	7.2	7.5	10.5	12.5
M12×1.5	2.55	2.7	4	3.5	5	4.6	6.8	7.7	8	11.2	13.4
M14	3.7	3.9	6	5.2	7.5	7	10	11.5	12	17	20
M14×1.5	4.1	4.3	6.6	5.7	8.3	7.5	11.1	12.5	13	18.5	22
M16	5.6	6	9	8	11.5	10.5	17.9	18.5	18	26	31
M16×1.5	6.2	6.5	9.7	8.6	12.5	11.3	17	19.5	20	28	33
M18	7.8	8.3	12.5	11	16	14.5	21	24.2	25	36	43
M18×1.5	9.1	9.5	14.5	12.5	18.5	16.7	24.5	27.5	28	41	49
M20	11.5	12	18	16	22	19	31.5	35	36	51	60
M20×1.5	12.8	13.5	20.5	18	25	22.5	35	39.5	41	58	68
M22	15.5	16	24.5	21	30	26	42	46	49	67	75
M22×1.5	17	18.5	28	24	34	29	47	52	56	75	85
M24	20.5	21.5	33	27	40	34	55	58	63	82	92
M24×1.5	23	25	37	31	45	38	61	67	74	93	103

Note) The standard torque values specified above are based on 70% of a bolt's elastic limit.

Note) The tensile force is calculated by multiplying the tensile strength by the cross-sectional area of a screw.

Note) A special screw should be tightened to about 85% of the standard torque. For example, a screw coated with MoS2 should be tightened to about 60 % of the standard torque.

## 5. About the engine

---

### Tightening torque of plug screw

M10	M12	M14	M16	M18	M22	M24	M26	M30
5.0	5.0	8.0	8.0	10.0	10.0	12.0	12.0	15.0

### Hollow screw (4-Hole) tightening torque

Material Classification	M8	M10	M12	M14	M16	M18	M22	M26	M30	M38
SM25C	-	1.6	2.5	3.5	4.5	5.5	9.0	13.0	18.0	30.0
SUM22L <sup>a</sup>	0.8	1.8	3.0	4.0	5.5	6.5	11.0	16.0	20.0	35.0
STS304	0.8	1.8	3.0	4.0	5.5	6.5	11.0	16.0	20.0	35.0

a. Applied to Doosan Engines

## 5. About the engine

### Engine disassembly

#### Engine disassembly procedure

#### **⚠ CAUTION**

- Prepare the necessary tools and genuine parts before engine disassembly.
- Prepare a shelf to keep removed parts.
- Keep the working area well lighted and clean.
- Keep your hands clean at all times during service.
- Keep parts removed from the engine in the removal order.
- Make sure that removed parts are not mixed and do not touch each other.

Disassemble the engine according to the following procedure:

1. Drain coolant.

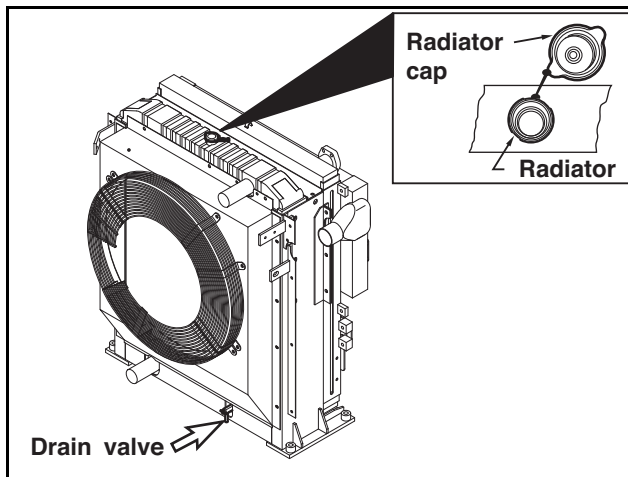

FG000494-E

- 1) Check that the engine and radiator is sufficiently cooled down.
- 2) Place a container in front of the coolant drain plug.
- 3) Remove the radiator cap.
- 4) Open the drain valve on the bottom of the radiator to drain coolant.
- 5) Remove the coolant drain plugs from the cylinder block and oil cooler.
- 6) Drain coolant into the prepared container.

- 7) After draining coolant, install the drain plug.

#### **⚠ DANGER**

- Never open the radiator cap while the engine is hot. If opening the radiator cap while the engine is still hot, hot coolant may spurt, resulting in a severe burn. Open the radiator cap after confirming that the engine is sufficiently cooled down.
- Put a label on the coolant container not to get mixed with other containers. If you swallow coolant, seek professional medical help immediately.

#### **⚠ WARNING**

Used coolant should be discarded according to the local regulations. Never discard used engine oil to the ground, ditch, sewer, river, sea, etc. Such action can pollute the environment. Discarding used engine oil improperly can result in punishment due to violation of the corresponding regulation.

#### **⚠ CAUTION**

When changing coolant, make sure that it is not left on any belt or electric part.

2. Separate the dipstick.
  - 1) Pull out the dipstick.
3. Drain engine oil.

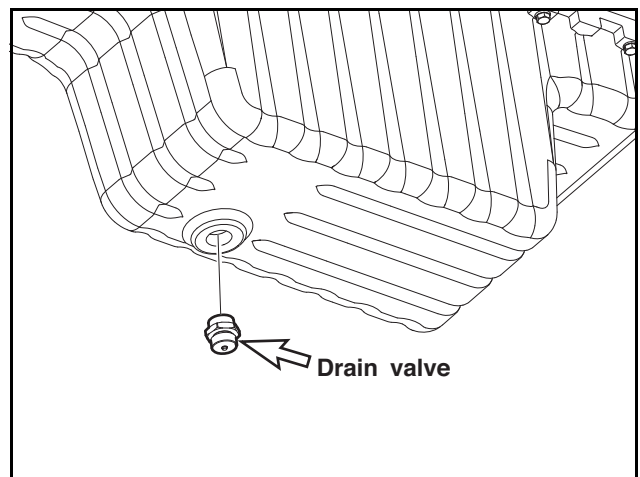

EK4OM033-E

- 1) Place a container under the engine to collect drained engine oil.
- 2) Remove the drain plug from the oil pan and drain engine oil into the prepared container.
- 3) Remove the oil filler cap.



## 5. About the engine

- 4) Remove the engine oil filter.
- 5) After draining engine oil, install the engine oil filter and drain plug.

### WARNING

Used oil should be discarded according to the local regulations. Never discard used engine oil to the ground, ditch, sewer, river, sea, etc. Such action can pollute the environment. Discarding used engine oil improperly can result in punishment due to violation of the corresponding regulation.

4. Remove the intercooler.

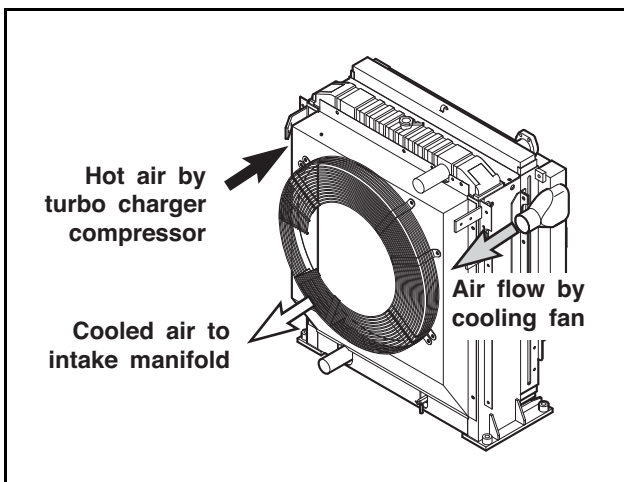

FG000496-E

- 1) Remove all the hoses and air pipes from the intercooler.
- 2) Unscrew the intercooler mounting bolts to remove the intercooler.
5. Remove the cooling fan.

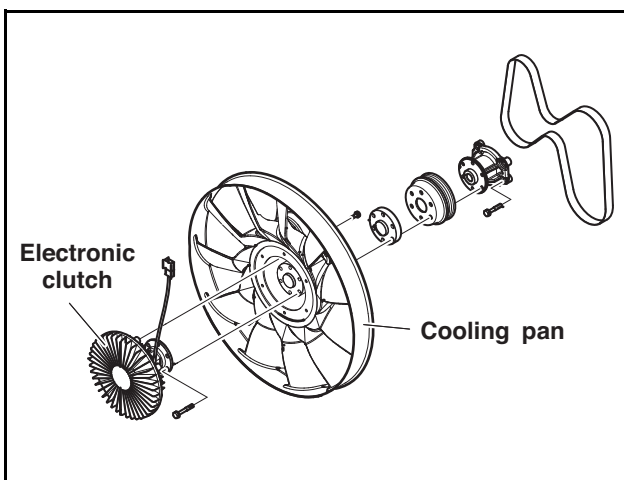

EK4OM071-E

- 1) Remove the fan guide and bracket.
- 2) Unscrew the flange mounting bolt to remove the flange and cooling fan.

6. Remove the belt.

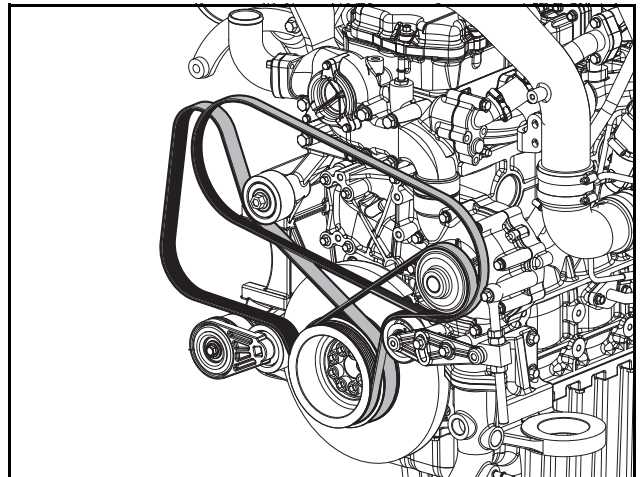

EDL06200014

- 1) Turn the Auto tensioner clockwise using a wrench.
- 2) Remove the belt.
- 3) Unscrew the Auto tensioner mounting bolts.
7. Remove the engine from the machine.
8. Disconnect the cables and harnesses of the engine from each sensor.
9. Remove the alternator and A/C compressor.

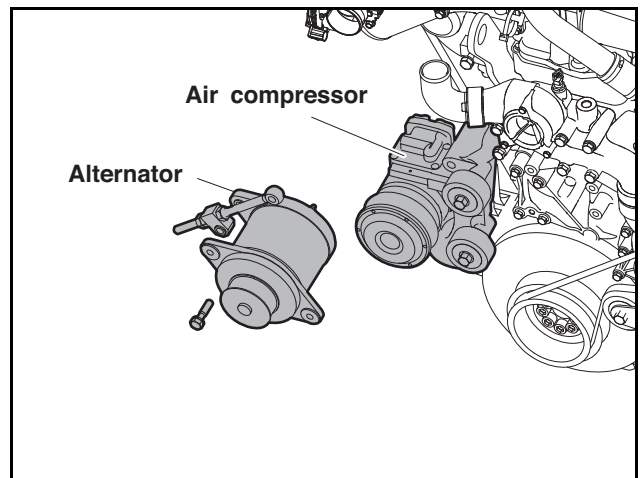

EK4OM043-E

- 1) Unscrew the mounting bolt to remove the alternator.
- 2) Unscrew the idle puller mounting bolt to remove the A/C compressor.

## 5. About the engine

10. Remove the breather.

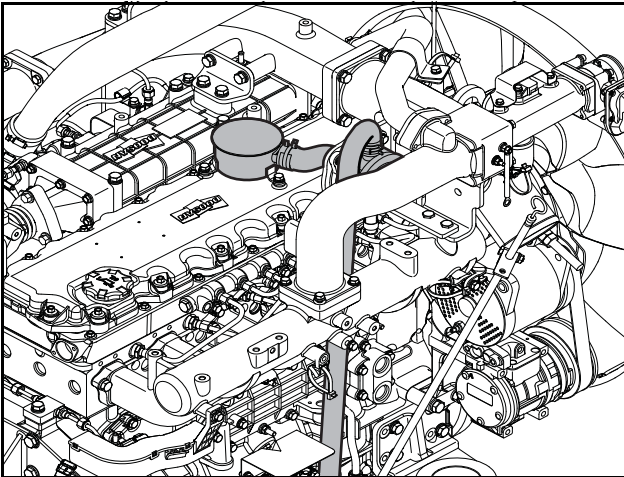

EK4OM042

- 1) Unscrew the mounting clamp screw to disconnect the rubber hose.
- 2) Remove the breather valve assembly.

11. Disconnect the air pipe and remove the air heater.

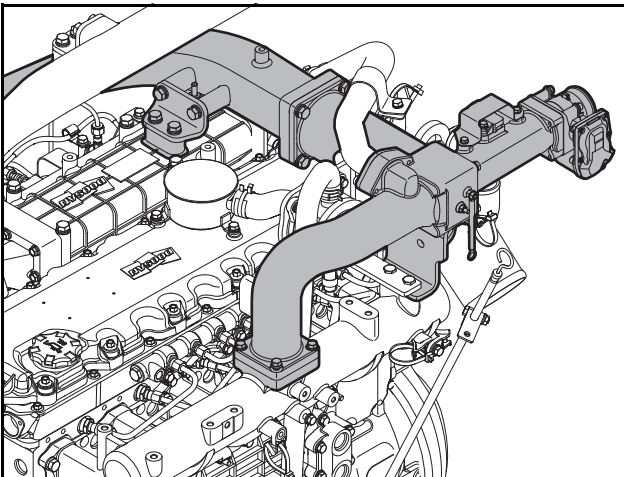

EK4OM044

- 1) Unscrew the mounting bolt to disconnect the air pipe and remove the air heater.

### CAUTION

Never let foreign materials enter the turbocharger.

12. Remove the fuel filter.

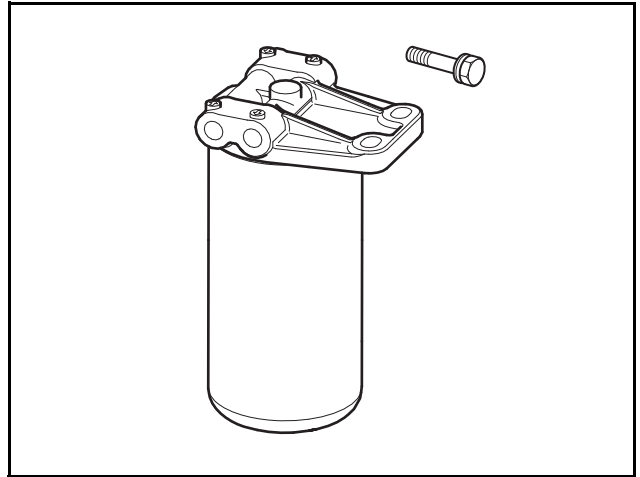

EK4OM011

- 1) Unscrew the hollow screw from the fuel filter and disconnect the fuel hose.
- 2) Unscrew the fuel filter mounting bolt to remove the fuel filter.

13. Disconnect the intake stake.

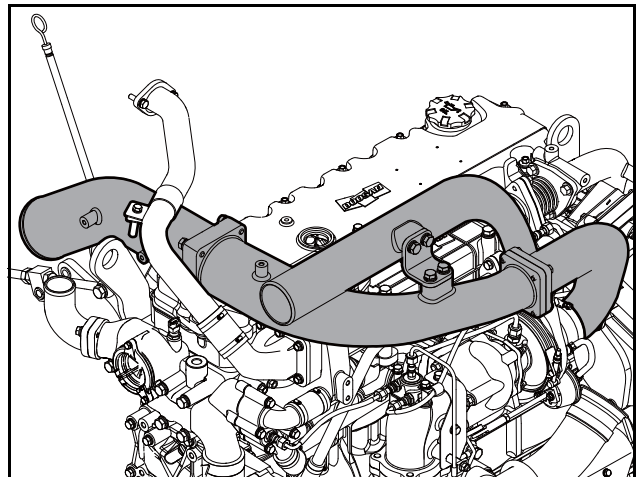

EK4OM015

- 1) Unscrew the mounting bolt to disconnect the air hose.
14. Separate the intake manifold.

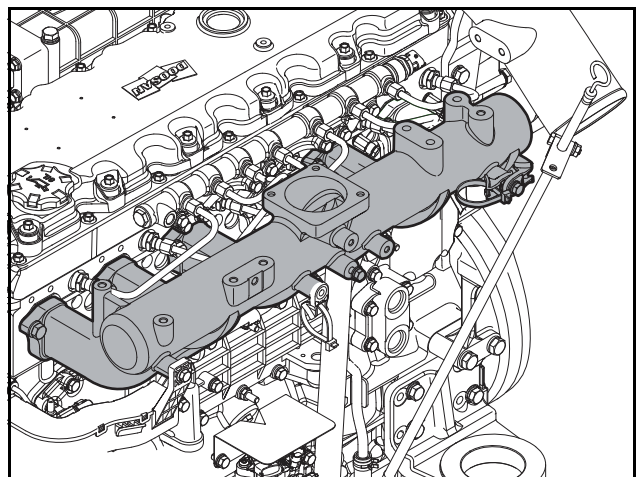

EK4OM045

## 5. About the engine

- 1) Unscrew the intake manifold mounting bolts to remove the intake manifold from the cylinder block.
  - 2) Remove the gasket and clean the gasket mounting surface thoroughly with a scraper.
15. Remove the common rail and high-pressure pipe.

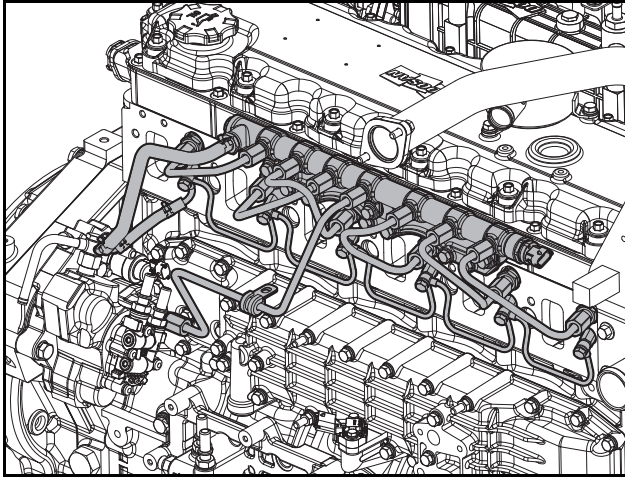

EDL06200021

- 1) Disconnect the high-pressure pipe between the fuel high-pressure connector and common rail.
- 2) Unscrew the common rail mounting bolts to remove the common rail.

### **⚠ CAUTION**

- Seal the common rail thoroughly after removing it to prevent foreign materials from entering it.
- Once the fuel high-pressure pipe is disconnected, it cannot be reused.

16. Remove the fuel high-pressure pump.

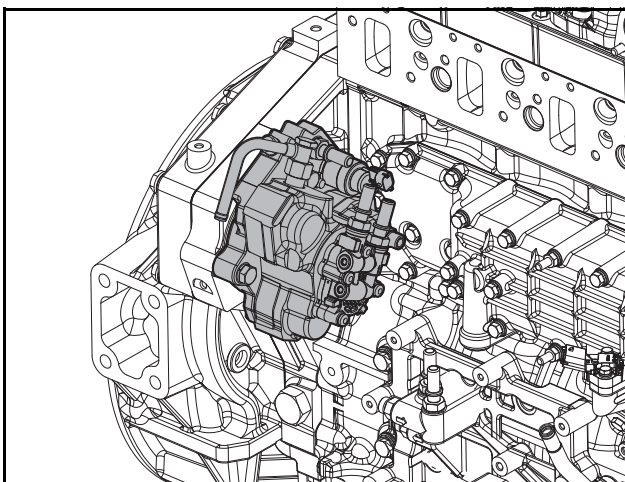

EDL06200022

- 1) Unscrew the fuel high-pressure pump mounting bolts to remove the fuel high-pressure pump.

### **⚠ CAUTION**

Seal the fuel high pressure pump to prevent from mixing foreign material into inside of the fuel.

17. Remove the EGR valve.

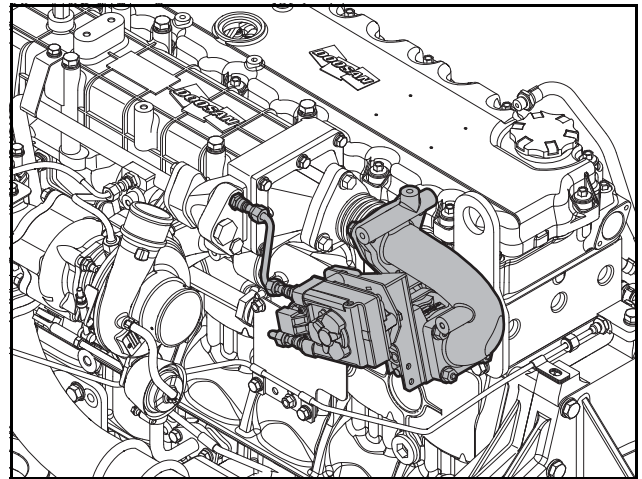

EK40M036

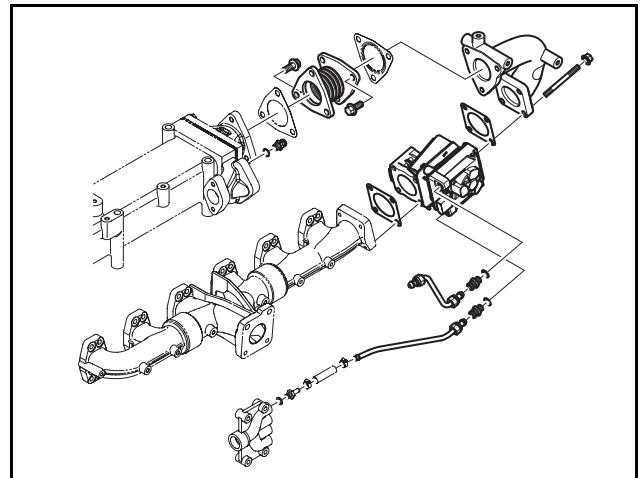

EK40M080

- 1) Unscrew the EGR valve mounting bolts to remove the EGR valve and exhaust manifold.
- 2) Unscrew the mounting bolts to remove the exhaust pipe from the EGR cooler.
- 3) Disconnect the coolant pipe from the EGR valve.

### **⚠ CAUTION**

Seal the EGR valve and exhaust pipe thoroughly after removing them to prevent foreign materials from entering them.

## 5. About the engine

18. Remove the EGR cooler.

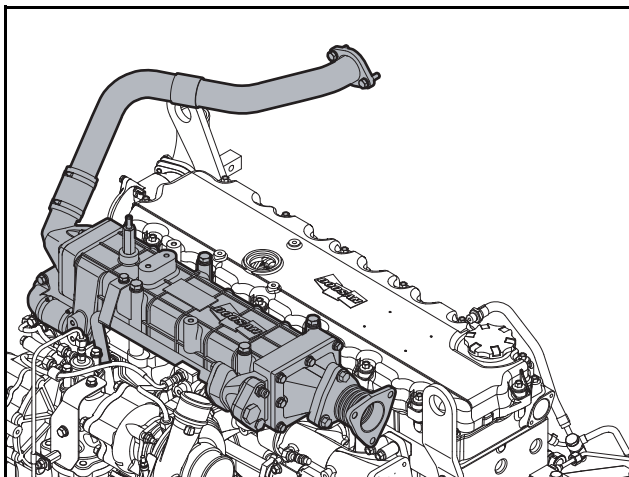

EK4OM037

- 1) Unscrew the EGR cooler and bracket connecting bolt to separate the EGR cooler.
- 2) Disconnect the pipe and hose from the EGR cooler.

### CAUTION

Seal the EGR cooler thoroughly after removing it to prevent foreign materials from entering it.

19. Remove the HC (HydroCarbon) injector.

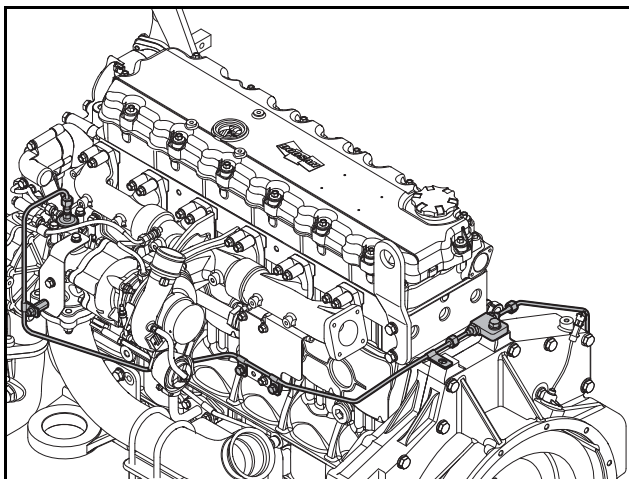

EK4OM038

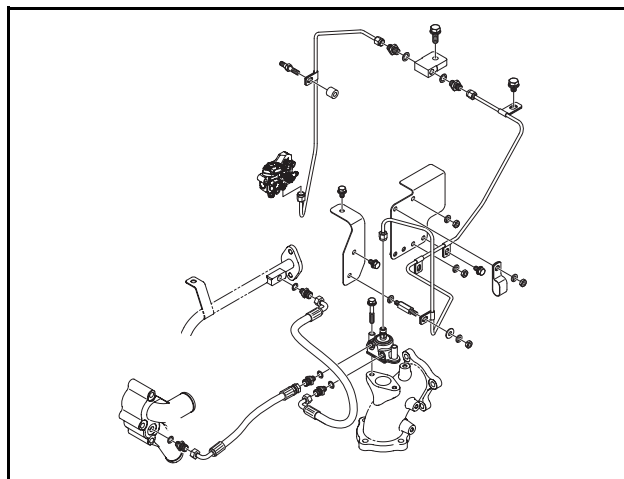

EK4OM098

- 1) Disconnect the HC injector pipe.
- 2) Disconnect the cooling hose from the HC injector.
- 3) Unscrew the HC injector mounting bolts to remove it from the exhaust pipe.

### CAUTION

Seal the HC injector, pipe and hose thoroughly after removing them to prevent foreign materials from entering them.

20. Remove HC dosing metering unit.

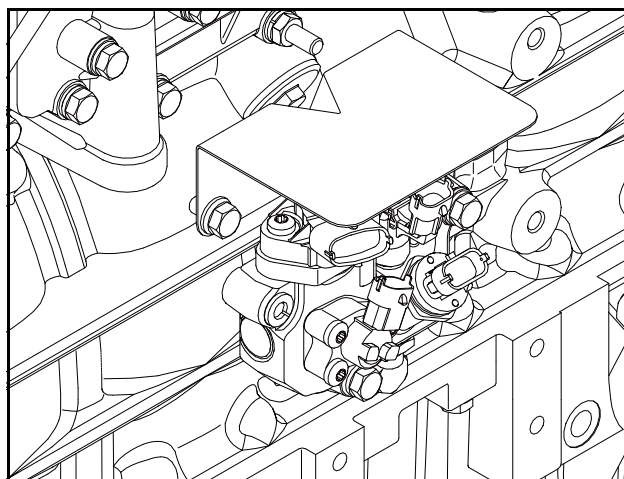

EK4OM106

- 1) Unscrew the mounting bolt of the HC dosing metering unit to remove it from the bracket.

### CAUTION

Seal the HC dosing metering unit thoroughly after removing it to prevent foreign materials from entering it.

## 5. About the engine

21. Remove the turbocharger.

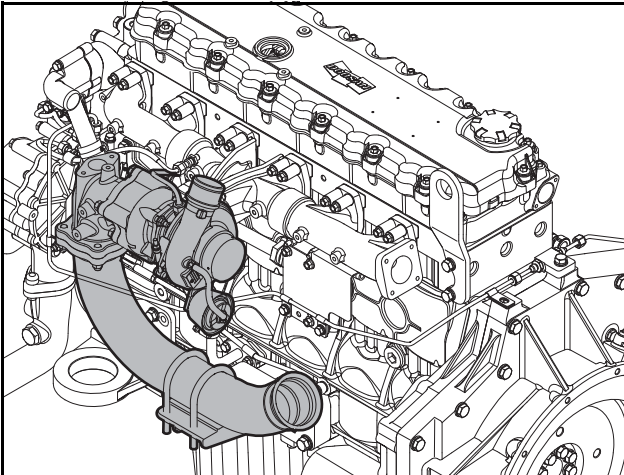

EK4OM048

- 1) Disconnect the intake stake from the turbocharger.
- 2) Disconnect the coolant hose from the turbocharger.
- 3) Disconnect the oil feed pipe and oil drain pipe between the cylinder block and turbocharger.
- 4) Unscrew the turbocharger mounting bolts to separate the turbocharger from the exhaust manifold.

22. Remove the exhaust manifold.

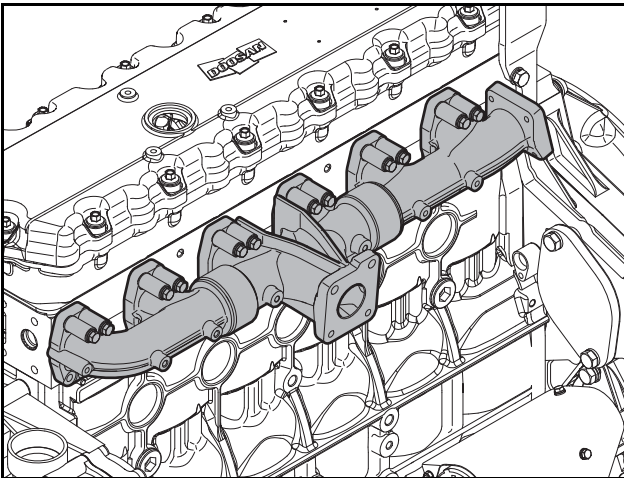

EK4OM020

- 1) Unscrew the exhaust manifold mounting bolts to remove the exhaust manifold.

### CAUTION

Do not reuse the removed gasket.

23. Disconnect the coolant pipe and thermostat.

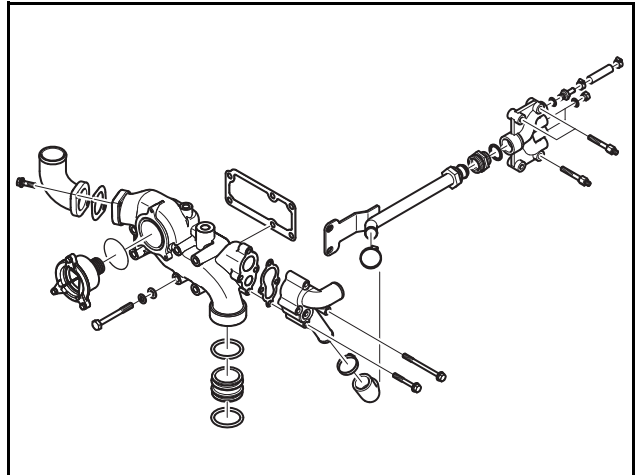

EK4OM074

- 1) Unscrew the coolant pipe mounting bolt to disconnect the coolant pipe from the thermostat housing.
- 2) Remove the coolant thermostat and O-ring.
- 3) Clean the gasket mounting surface of the coolant pipe with a scraper thoroughly.

### CAUTION

Make sure that the gasket residual does not enter the coolant passage.

24. Remove the coolant pump.

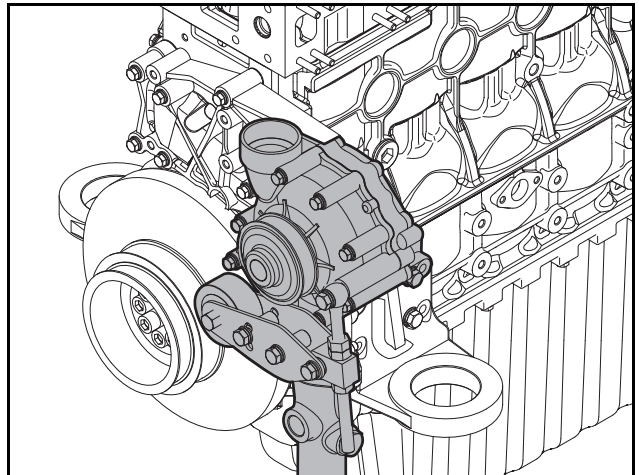

EK4OM049

## 5. About the engine

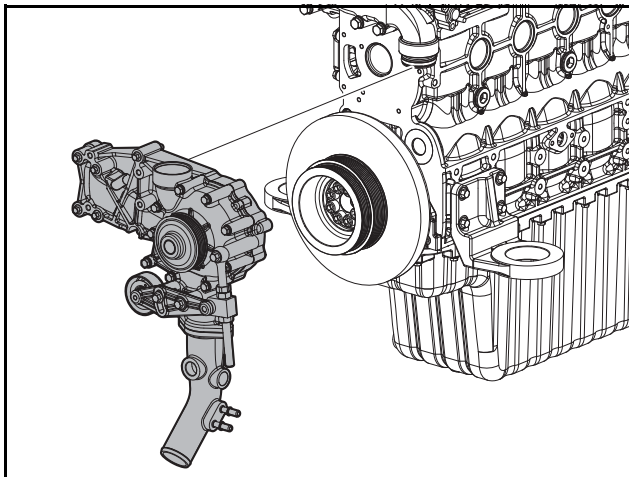

EDL06200016

- 1) Unscrew the bracket mounting bolts for the coolant pump and oil cooler.
- 2) Unscrew the bolt (1 EA) for the oil cooler.
- 3) Unscrew the coolant pump mounting bolts to remove the coolant pump.
- 4) Remove the O-ring for the coolant pump.

### CAUTION

Do not reuse the O-ring.

25. Remove the start motor.

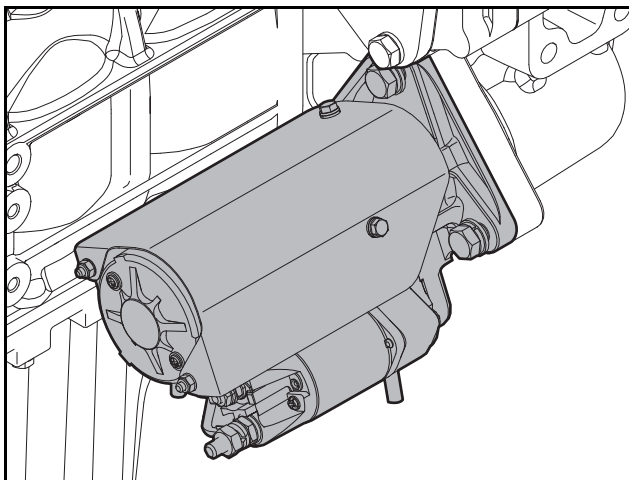

EK4OM050

- 1) Unscrew the start motor mounting nut and remove the start motor with care. Be careful not to damage its gear.

26. Remove the oil filter.

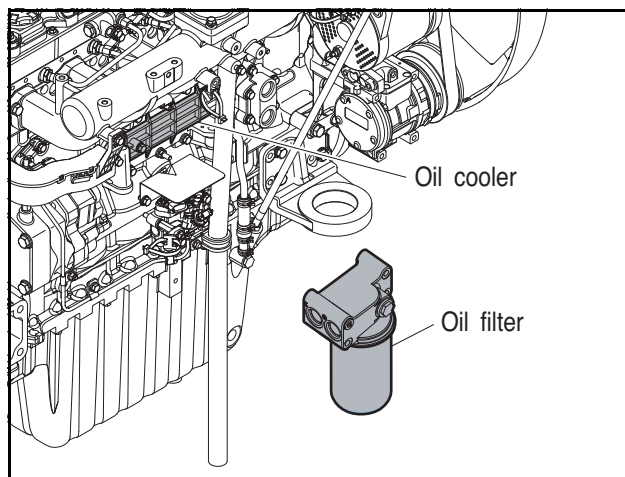

EK4OM041-E

- 1) Remove the oil filter cartridge using a special service tool.
27. Remove the vibration damper.

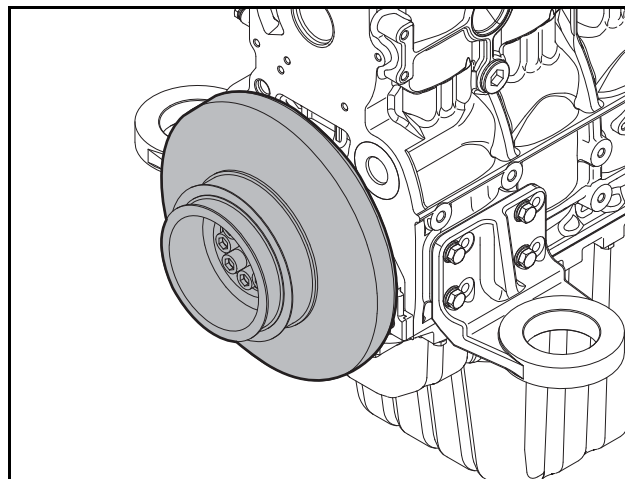

EK4OM051

- 1) Unscrew the mounting bolts of the vibration damper and crank pulley in the reverse order to remove the vibration damper assembly.
28. Remove the cylinder head cover.

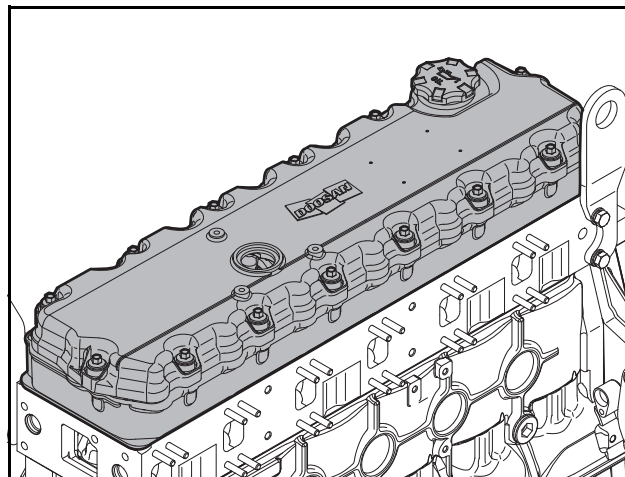

EK4OM052

## 5. About the engine

- 1) Unscrew the cylinder head cover mounting bolts to remove the cylinder head cover.
  - 2) Unscrew the intermediate cover mounting bolts to remove the intermediate cover.
29. Remove the rocker arm.

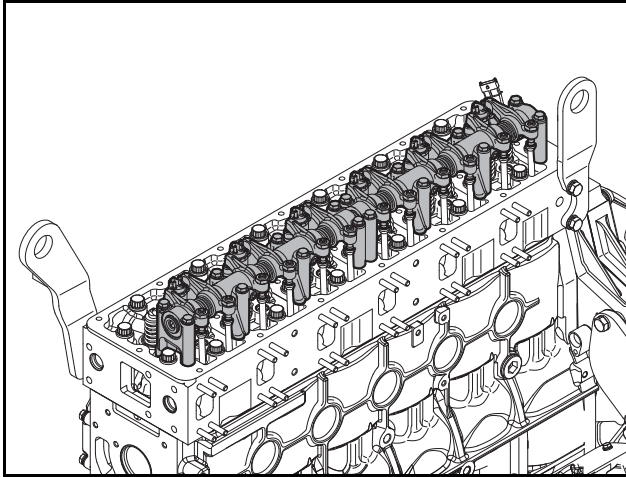

EK4OM053

- 1) Unscrew the rocker arm bracket mounting bolts in the reverse order to remove the rocker arm assembly.
30. Remove the push rod.

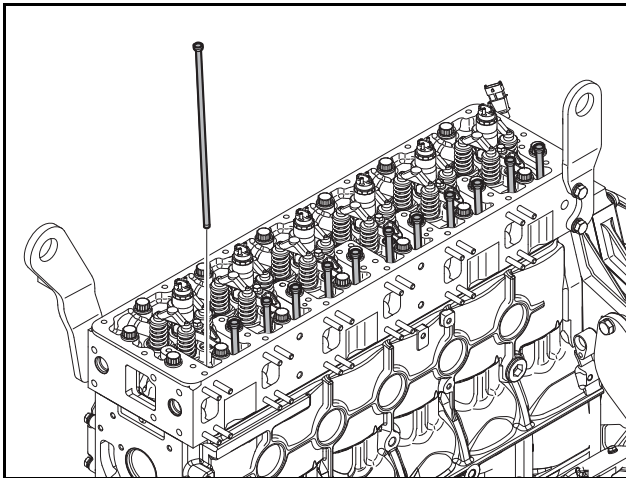

EK4OM054

- 1) Remove the push rod.

31. Remove the fuel injector.

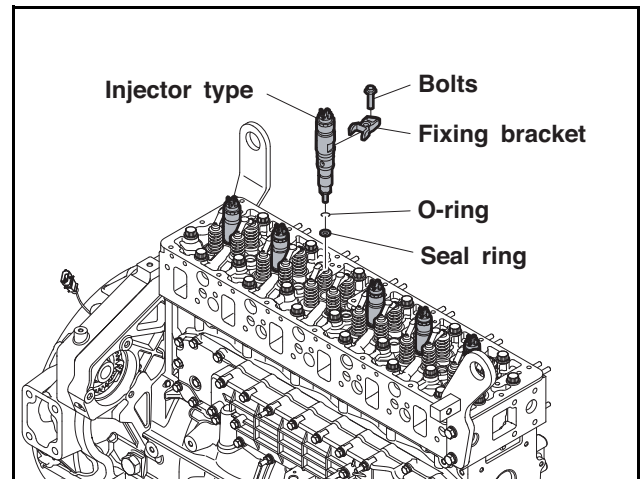

EK4OM055-E

- 1) Unscrew the fuel high-pressure connector mounting bolts to disconnect the fuel high-pressure connector.
- 2) Remove the harness from the injector.
- 3) Unscrew the injector mounting bracket bolts to remove the injector.

### **⚠ CAUTION**

**Be careful not to damage the nozzle during removing the injector.**

- 4) Remove the seal ring from the nozzle hole from the cylinder head.

### **⚠ CAUTION**

**To remove the injector, unscrew the fuel high-pressure connector mounting nut to disconnect the fuel high-pressure connector completely. Then, unscrew the caliper mounting bolt to remove the injector.**

## 5. About the engine

32. Remove the cylinder head.

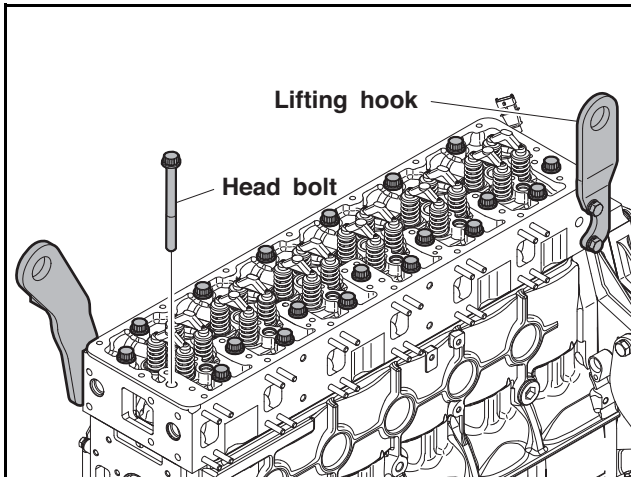

EK4OM056-E

- 1) Unscrew the cylinder head bolts in the reverse order of tightening to remove the cylinder head.
  - Step 1: Unscrew the bolt for 1 to 2 threads.
  - Step 2: Unscrew the bolt completely to remove it.
- 2) Remove the cylinder head bolts in these two steps.
- 3) Keep the removed bolts in order with care, being careful not to damage their threads.

---

### **⚠ CAUTION**

**Make sure that the bolts are not hit by each other.**

---

- 4) Remove the cylinder head gasket.
- 5) Remove foreign materials from the surface of the cylinder head and block.

---

### **⚠ CAUTION**

**Be careful not to damage the mating surface.**

---

- 6) Unscrew the mounting bolt of the lifting hook from the cylinder head to remove the lifting hook.

33. Remove the valve and valve stem seal.

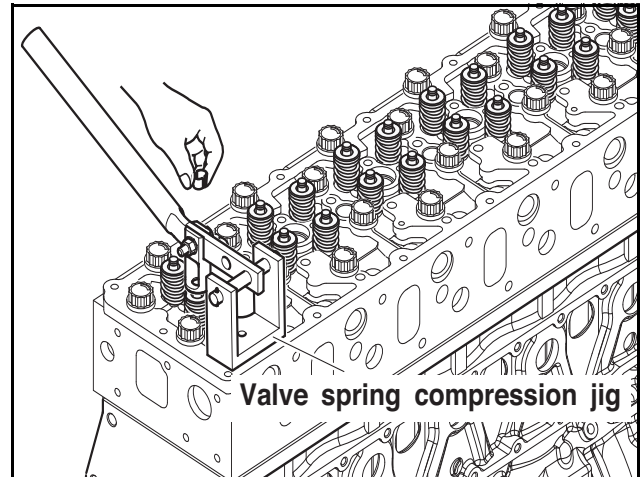

EG9OM078-E

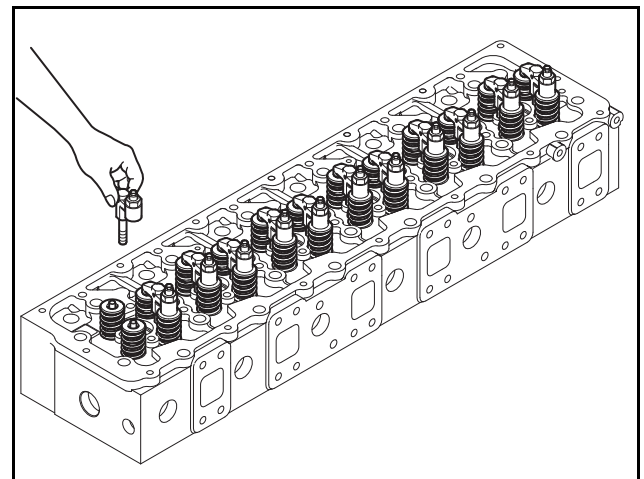

EJ9OM042

- 1) Press the valve spring and retainer with the valve spring compressor to remove the valve cotter.
- 2) Remove the valve spring and retainer.
- 3) Remove the calipers.
- 4) Use a general service tool to remove the valve stem seal.

---

### **⚠ CAUTION**

**Do not reuse the valve stem seal.**

---

- 5) Remove valve.
- 6) Unscrew the mounting bolt of the lifting hook from the cylinder block to remove the lifting hook.



## 5. About the engine

34. Remove the oil cooler.

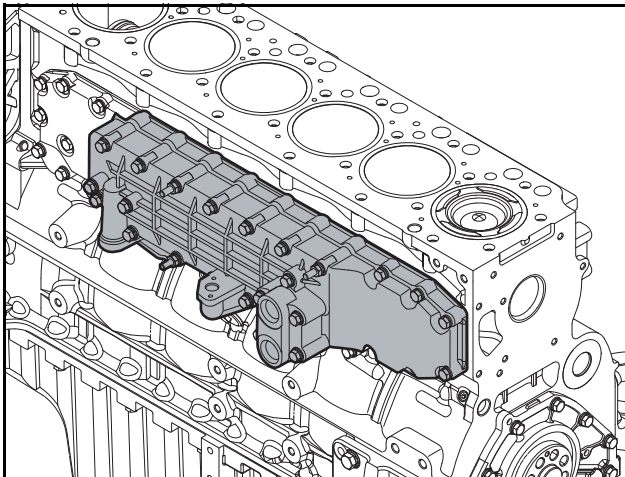

EK4OM057

1) Unscrew the oil cooler mounting bolts to remove the oil cooler.

35. Remove the oil pan.

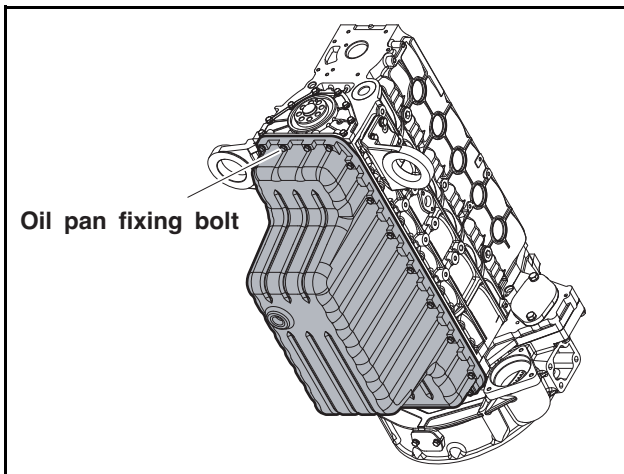

EK4OM058-E

1) Unscrew the oil pan mounting bolts to remove the oil pan.

2) Remove the oil pan gasket.

36. Remove the front oil seal and cover.

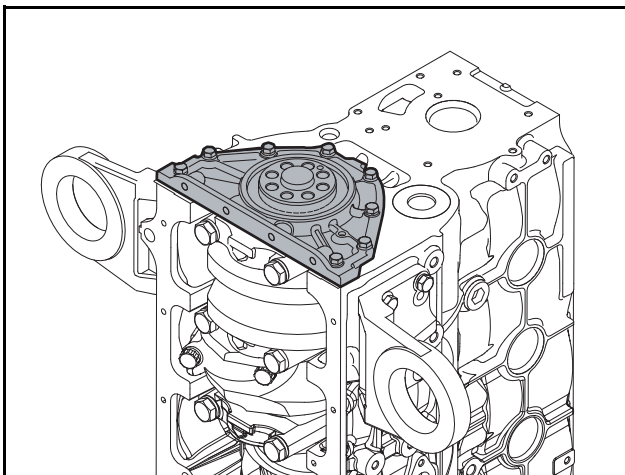

EK4OM097

1) Remove the oil seal using a oil seal removing tool.  
2) Unscrew the gear case cover mounting bolt to remove the oil seal cover.

37. Remove the oil pump and disconnect the pipe.

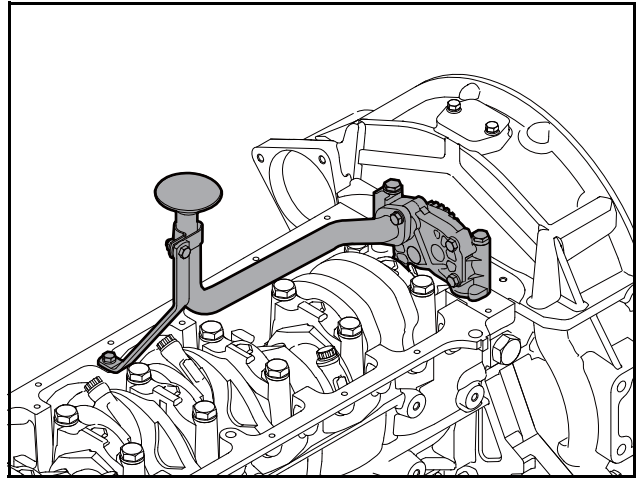

EK4OM059

1) Unscrew the oil suction pipe mounting bolt to remove the bracket.

2) Unscrew the oil pump pipe mounting bolts to disconnect the suction pipe and feed pipe.

3) Unscrew the oil pump mounting bolts to remove the oil pump.

38. Remove the flywheel.

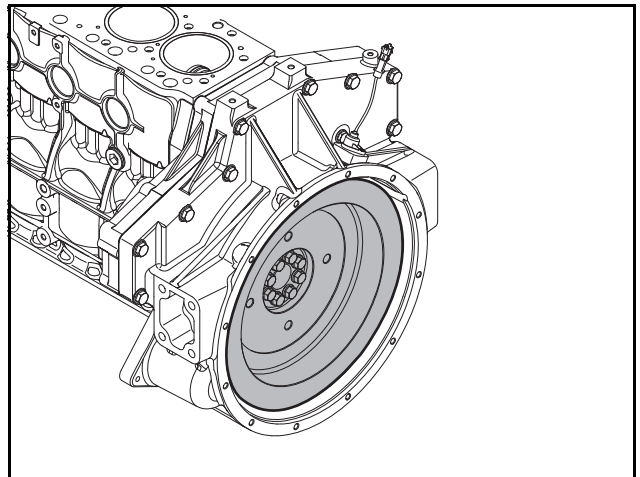

EK4OM060

1) Unscrew the flywheel mounting bolts and install the guide bolt to remove the flywheel.

2) Unscrew the bolts in the reverse order of their tightening to remove the flywheel.

## 5. About the engine

### 39. Flywheel housing

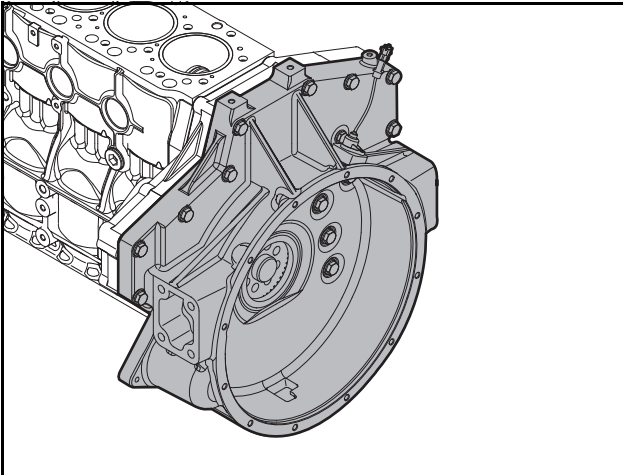

EK4OM061

- 1) Unscrew the flywheel housing mounting bolts to remove the flywheel housing.
- 2) Remove the flywheel housing oil seal.

### 40. Remove the cam gear and idle gear.

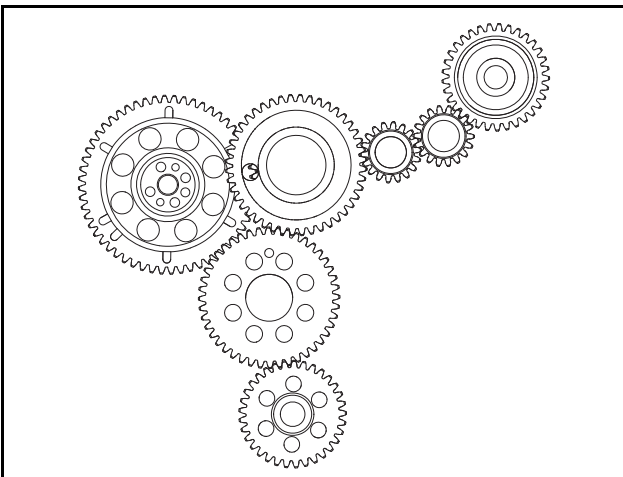

EK4OM062

- 1) Unscrew the camshaft gear mounting bolts to remove the camshaft gear.
- 2) Unscrew the idle gear mounting bolts to remove the idle gear.

### 41. Remove the timing gear case.

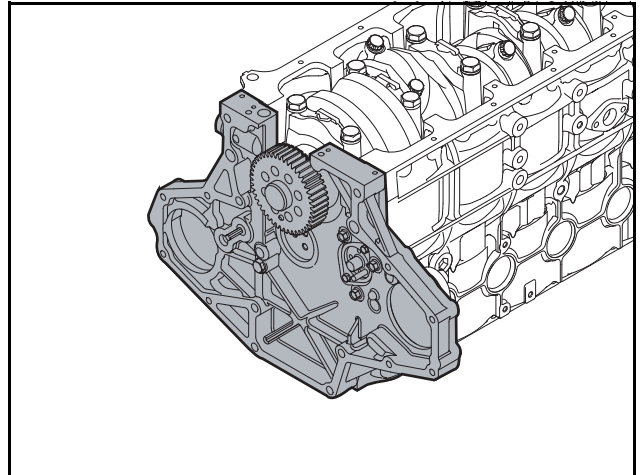

EK4OM063

- 1) Unscrew the timing gear case mounting bolts.
- 2) Tap the left and right sides on the back of the contact surface of the timing gear case with a urethane hammer gently to remove the timing gear case.

### 42. Remove the piston and connecting rod.

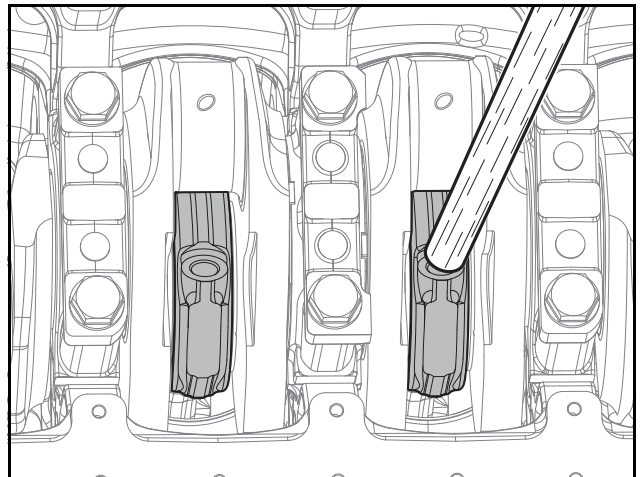

EDL08190020

- 1) Unscrew the connecting rod cap bolts in the reverse order of their tightening.  
Note) Unscrew these bolts in two steps as the cylinder head bolts.
- 2) Tap the top and bottom of the connecting rod cap with a urethane hammer lightly to remove the bearing cap and bearing.
- 3) Push the connecting rod from the oil pan side toward the cylinder head with a wooden stick to separate the piston assembly.
- 4) Keep the removed pistons in the corresponding cylinder order and make sure that they are not hit by each other.
- 5) Install the connecting rod caps to their corresponding connecting rods loosely. Be careful not to mix them.

## 5. About the engine

43. Remove the piston.

- 1) Remove the snap ring of the piston pin using pliers.

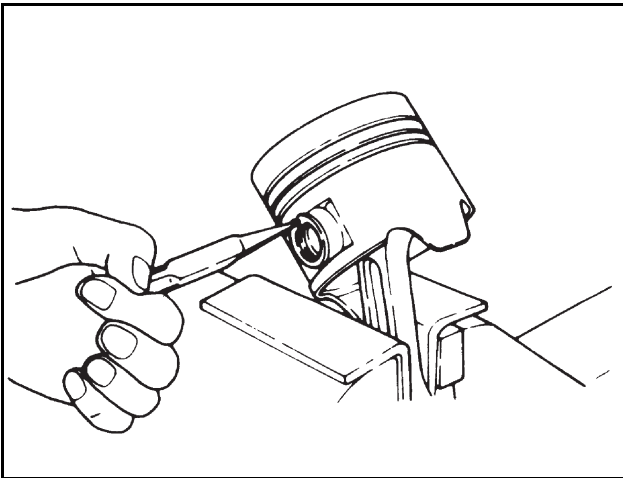

EA3M2029

- 2) Tap the piston pin with a wooden stick gently to remove the piston.

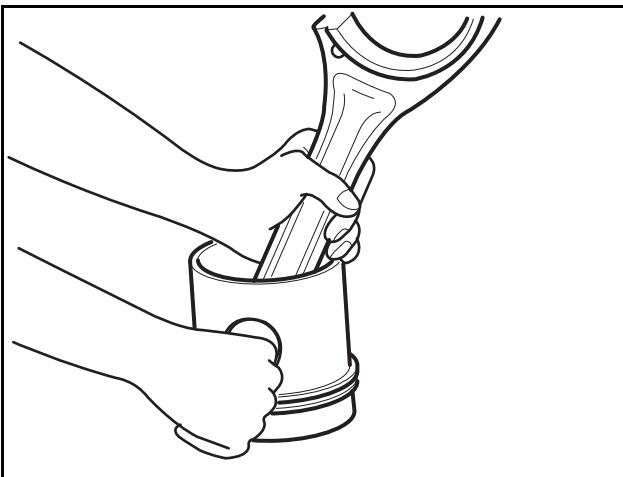

EAMD088I

- 3) Remove the piston ring using piston ring pliers.

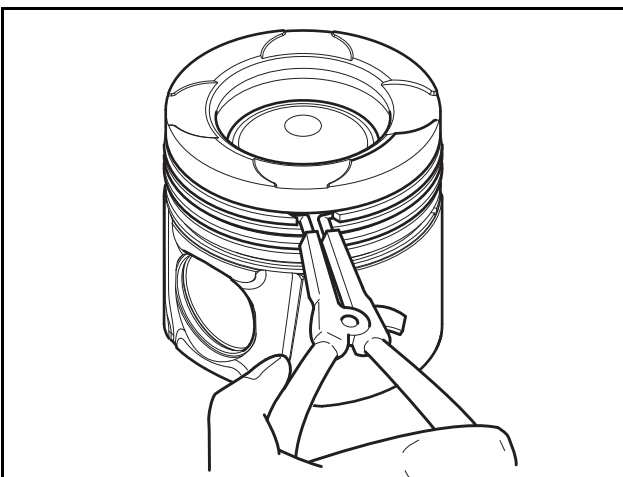

EH4OM048

- 4) Remove carbon from the piston completely and clean it.

44. Remove the bearing cap.

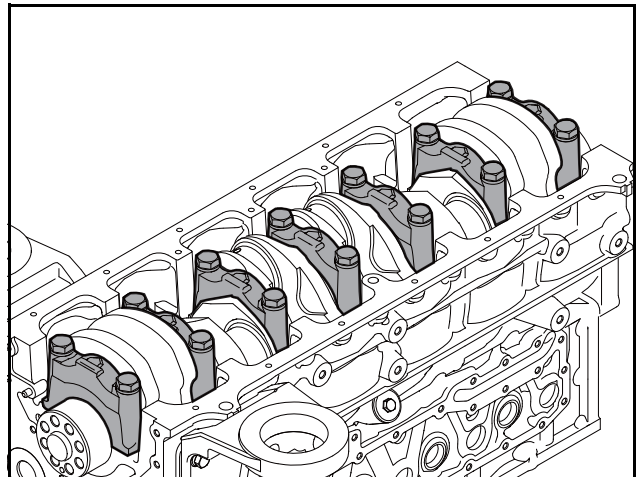

EK4OM064

- 1) Unscrew the bearing cap mounting bolts in the reverse order of their tightening to remove the bearing cap.

Note) Unscrew these bolts with the same method for the cylinder head bolts.

- 2) Keep the bearing caps in order.

45. Remove the crankshaft.

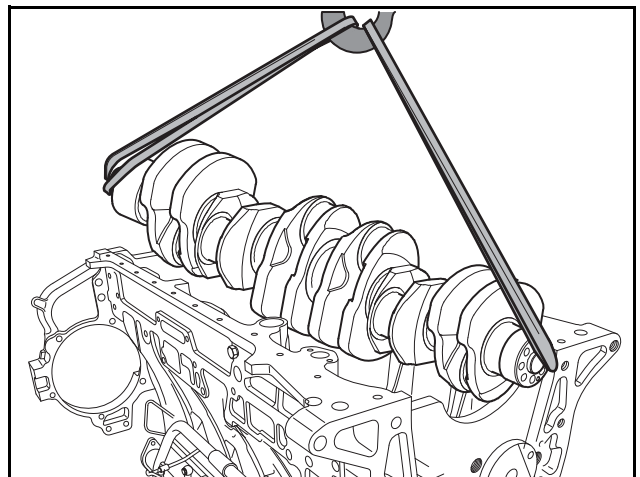

EI4OM090

- 1) Fit the bolts to both sides of the crankshaft temporarily.
- 2) Connect a rope to the bolts and lift the crankshaft with a crane. Be careful not to damage the crankshaft.
- 3) Store the removed crankshaft on a safe special shelf so that it is not deformed or damaged.
- 4) Remove and store the main bearings in order.

### **⚠ CAUTION**

- Make sure that the main bearing and bearing caps are not mixed.
- Fit the main bearings to their bearing caps temporarily to prevent mixing.

## 5. About the engine

46. Remove the oil spray nozzle.

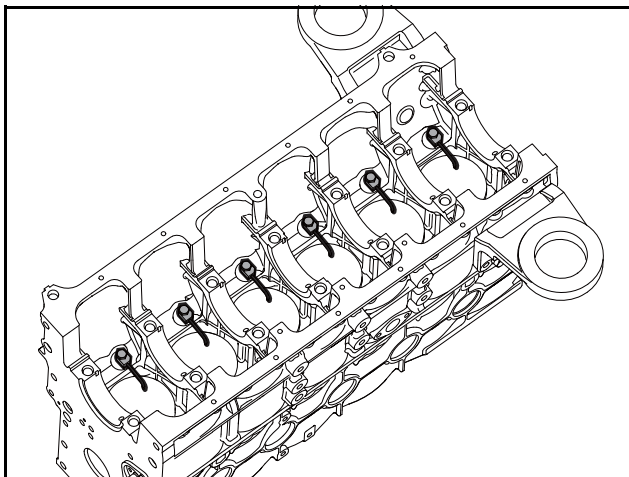

EK4OM065

- 1) Unscrew the oil spray nozzle valve mounting screw to remove the oil spray nozzle.

47. Remove the camshaft and tappet.

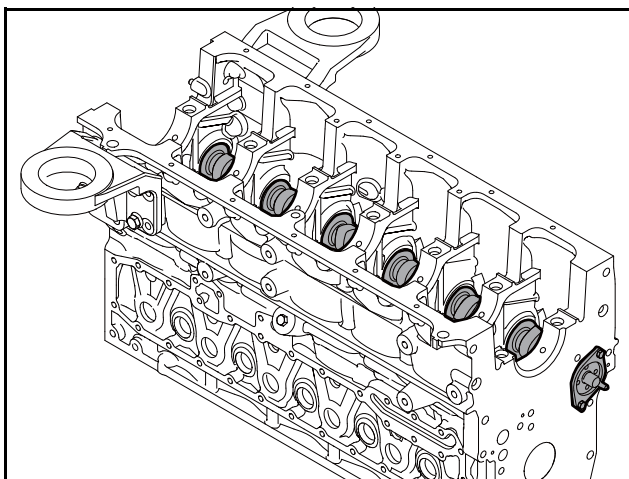

EK4OM066

- 1) To prevent damage of the camshaft, pull it out while turning it.
- 2) Store the removed camshaft on a safe special shelf so that it is not deformed or damaged.
- 3) Remove the tappet.

---

### CAUTION

---

**Check for damage, scratch and wear. If any abnormal condition is found, replace it.**

---

48. Remove the cylinder liner.

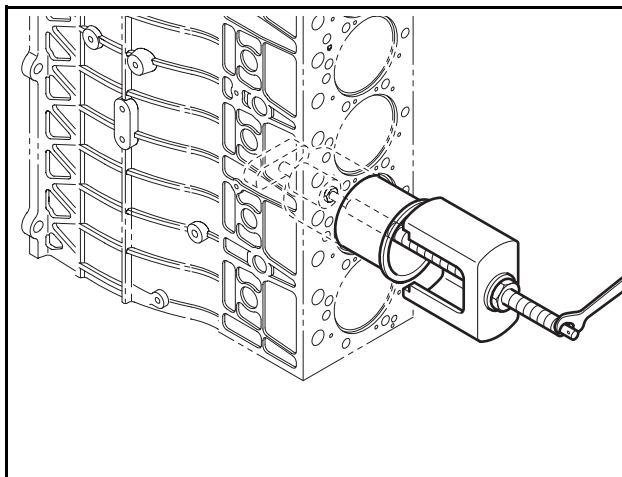

EJ9OM052

- 1) Be careful not to damage the cylinder block when removing the cylinder liner.
- 2) Remove the cylinder liner with its removing tool and hands.

### Engine assembly

#### Engine assembly sequence

#### **⚠ CAUTION**

- Clean all the removed parts thoroughly. Especially, clean the oil and coolant passages with compressed air thoroughly to eliminate any restriction.
- Organize general tools and special service tools for engine assembly.
- Prepare clean engine oil to apply onto moving parts.
- Prepare service parts, such as sealant and gasket.
- Replace any used gasket, seal ring and consumables with new ones.
- Each bolt should be tightened to the specified torque according to the tightening order. Never over-tighten it.
- After installing the engine components, check their proper operation.
- After primary assembly, check if any bolt is loose.
- Keep your hands clean at all times during work.

Assemble the engine according to the following procedure:

1. Install the cylinder block.
- 1) Place a wooden block or thick paper on the ground of the working area to prevent damage of the cylinder head mounting surface. Then, set the head mounting surface toward the ground.
2. Install the cylinder liner.

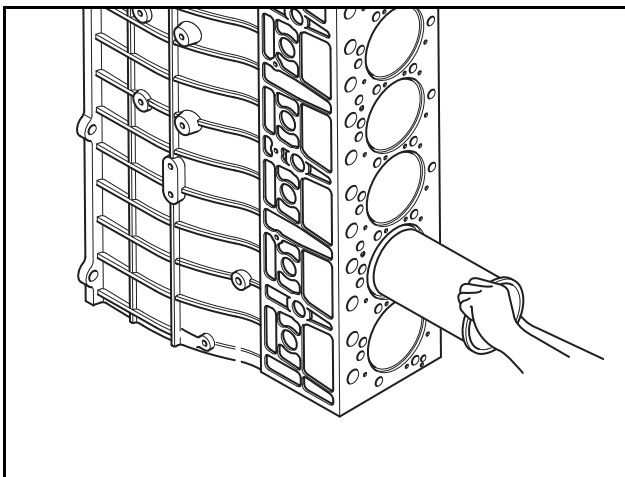

EE10M061

- 1) Stand the cylinder block with its flywheel side facing the ground.
- 2) Clean the flange mounting surface and inside of the liner with compressed air thoroughly.
- 3) After cleaning the cylinder liner, dry it completely and insert it into the cylinder block with hands.

- 4) Apply engine oil to the inside of the cylinder liner.
3. Install the oil spray nozzle.

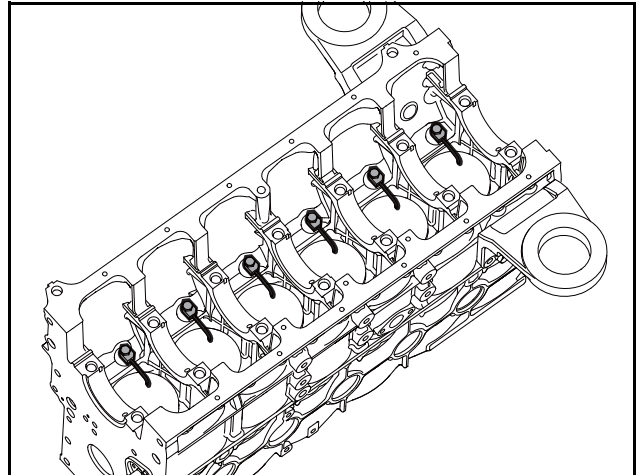

EK40M065

- 1) Align the oil spray nozzle with the groove of the cylinder block using the oil spray nozzle installing jig.
- 2) Install the relief valve.
- 3) Tighten the mounting bolt to 2.1 kg·m.
4. Install the crankshaft.
- 1) Make sure to align the holes of the main bearing with the machined oil holes (2 EA) on the cylinder block during installation.

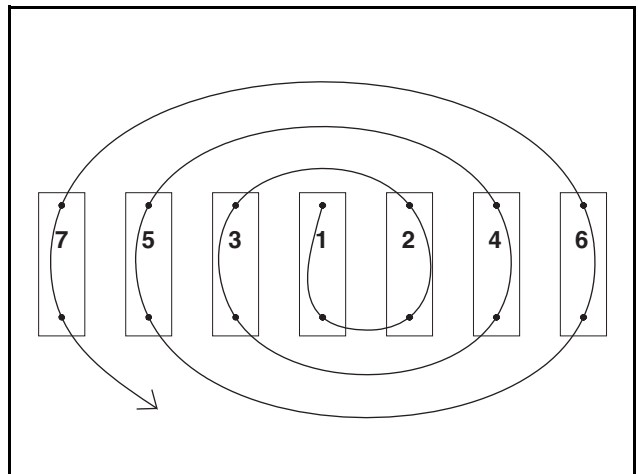

EH60M062

## 5. About the engine

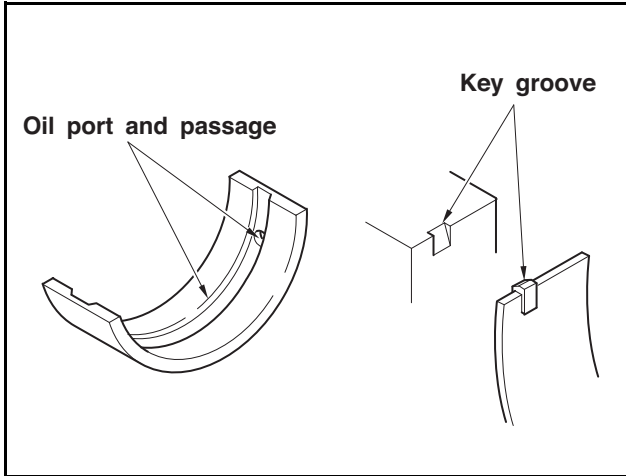

EA0M4083-E

- 2) Apply clean engine oil to the bearing surface.
- 3) Fit the bolts to both sides of the crankshaft temporarily. Then, place the crankshaft on the cylinder block using the mounting bolts.

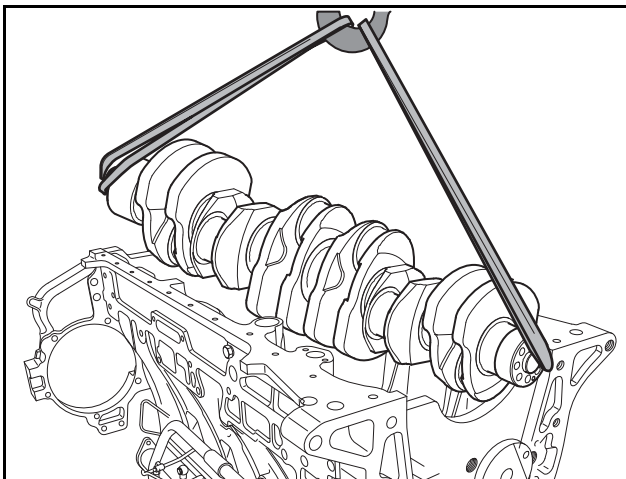

EI4OM090

- 4) Apply engine oil to the pin and journal of the crankshaft.
- 5) After oil application, install the thrust washer with its oil groove facing the outside.

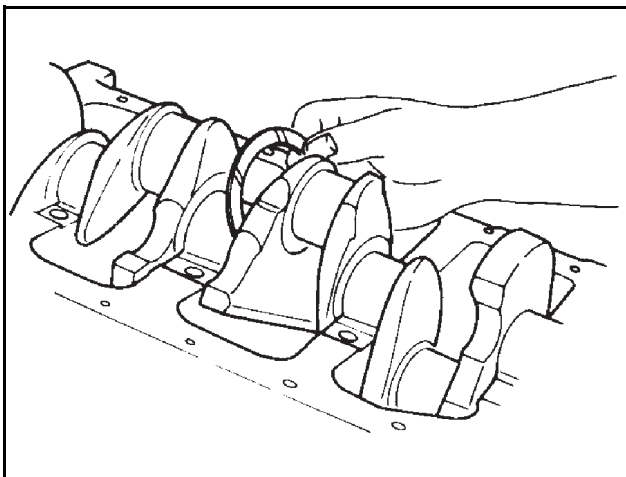

EAMD076S

- 6) Install the bearing and thrust washer to the bearing cap.

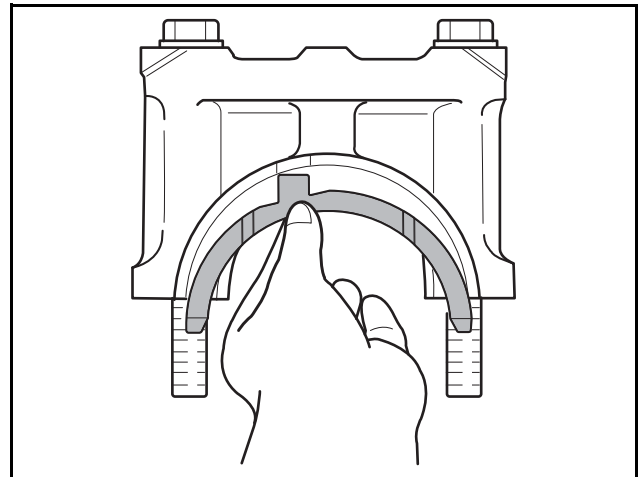

EDL06200013

- 7) Apply oil to the bearing and thrust washer.
- 8) Install the bearing caps correctly by matching their numbers with the cylinder block numbers.
- 9) Tighten the bearing cap bolts to the specified tightening torque in the specified order.

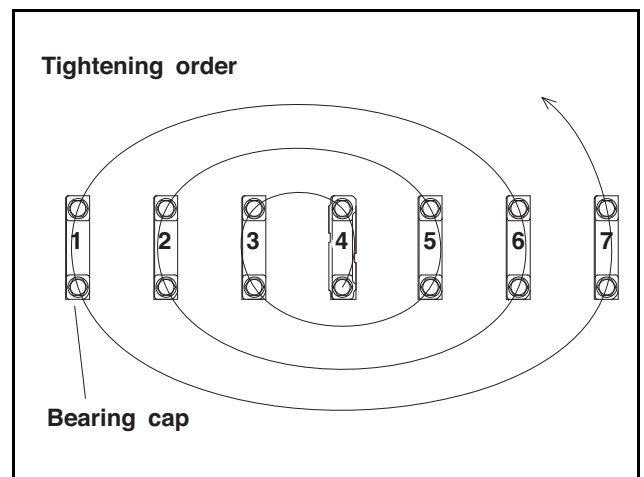

EH8OM018-E

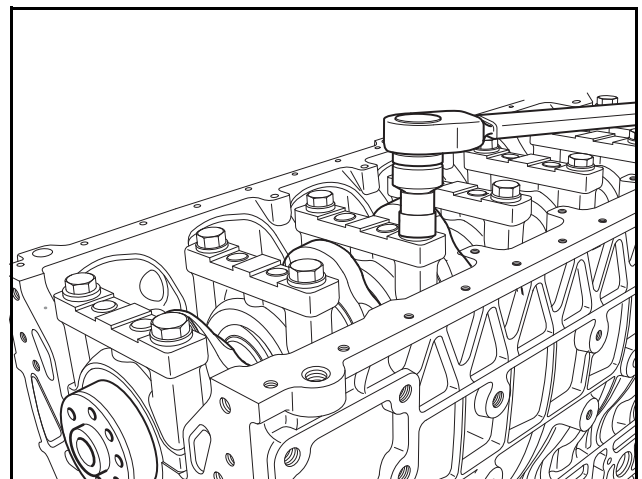

EH8OM017

- 10) Tighten both bolts evenly to set the bearing cap tight.

## 5. About the engine

- 11) Tighten the main bearing bolt to 6 kg·m + 90°.
- 12) Tighten the bearing caps in the following order:  
4-3-5-2-6-1-7.
- 13) Rotate the installed crankshaft for 2 to 3 turns to check its free motion.
5. Install the tappet and camshaft.

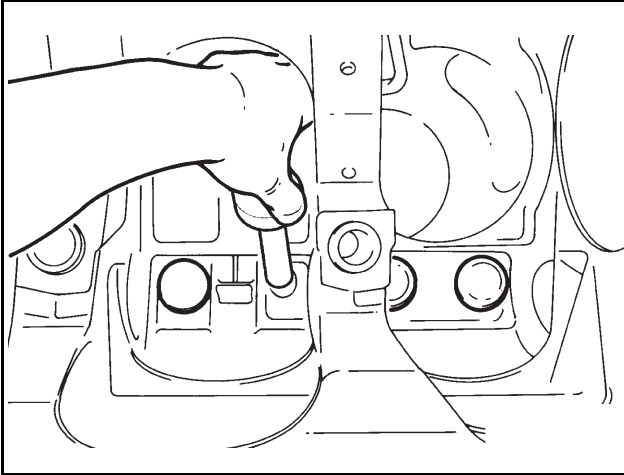

EAMD072S

- 1) Cool a new bushing in dry ice for approx. 2 hours.
- 2) Press the new bushing into the cam bushing position of the cylinder block using a bench press.
- 3) After pressing it in, measure the inside diameter of the cam bushing to check for its deformation.
- 4) Apply engine oil to the face of the tappet and insert the tappet into its hole of the cylinder block.
- 5) Apply engine oil to the camshaft hole and camshaft journal sections of the cylinder block.
- 6) Insert the camshaft into its hole of the cylinder block.
6. Install the timing gear case.

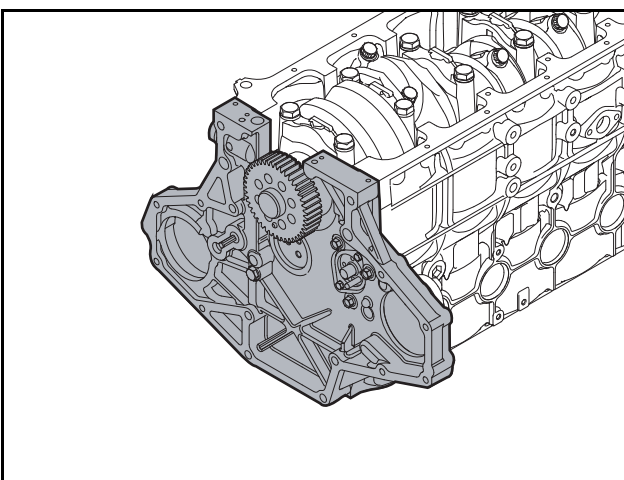

EK4OM063

- 1) Install the gasket to the cylinder block using a reference pin.
- 2) Align the pin hole of the timing gear case with the reference pin.
- 3) Install the timing gear case to the cylinder block.

- 4) Set it tightly against the cylinder block by tapping its left and right with a urethane hammer.
- 5) Tighten the relief valve to 2.6 kg·m.
- 6) Tighten the timing gear case mounting bolts to 4.4 kg·m.

### **⚠ CAUTION**

**When tightening the bolts, tighten the bolts on both ends first and tighten the remaining bolts.**

7. Install the fuel high-pressure pump.

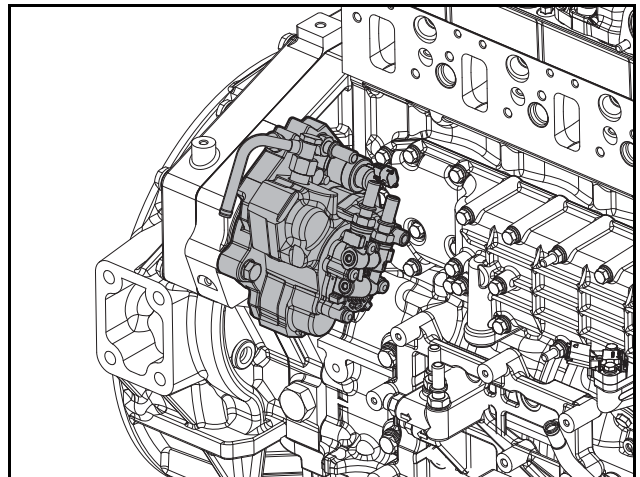

EDL06200022

- 1) Install the gear of the fuel high-pressure pump using its jig.
- 2) Tighten the gear nut to 11kg·m.
- 3) Tighten the mounting bolt to 4.4 kg·m.
- 4) Install the fuel high-pressure pump to the timing gear case on the back of the flywheel housing.
- 5) Tighten the flow screw to 3.0 kg·m.
- 6) Tighten the nipple to 4.4 kg·m.
- 7) Tighten the mounting bolts to the specified torque in the correct order.
8. Install the gear system.

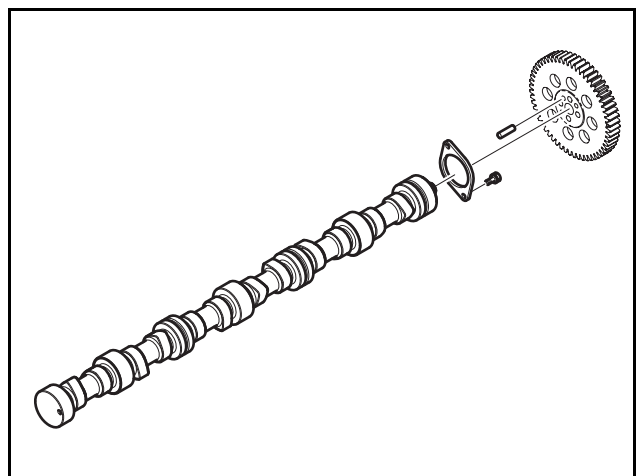

EK4OM017

## 5. About the engine

- 1) Install the thrust washer to the camshaft.
- 2) Install the cam gear, aligning it with the pin hole of the camshaft.
- 3) Tighten the camshaft thrust washer to 1.0 kg·m.
- 4) Tighten the camshaft gear mounting bolt to 3.1 kg·m.

### CAUTION

**When installing the gears, install the camshaft gear, idle gear, fuel high-pressure pump idle gear and fuel high-pressure pump in this order.**

- 5) Install the idle gear while aligning the marks on the crankshaft gear, camshaft gear and idle gear.

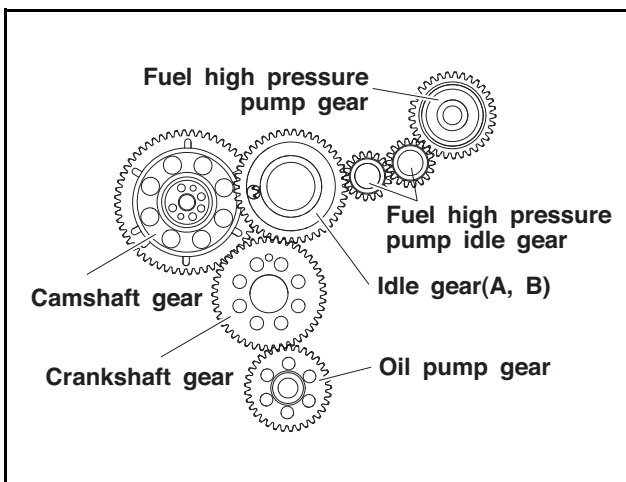

EK4OM076-E

- Gear mark

Crankshaft gear - idle gear (A)	“0” and “0”
Camshaft gear - idle gear (B)	“1” and “1”

- 6) Tighten the step idle gear to 6.2 kg·m.
- 7) Tighten the fuel high-pressure pump idle gear to 6.2 kg·m.
- 8) Use a feeler gauge to check the backlash and end play of the gear.

- Backlash

Measuring position	Standard (mm)
Camshaft gear and idle gear	0.074 - 0.163
Fuel high-pressure pump gear and idle gear	0.103 - 0.182
Crankshaft gear and oil pump drive gear	0.073 - 0.239

- End play

Measuring position	Standard (mm)
Camshaft gear	0.280 - 0.430
Step idle gear	0.107 - 0.183
Fuel high-pressure pump idle gear	0.078 - 0.140

9. Install the flywheel housing.

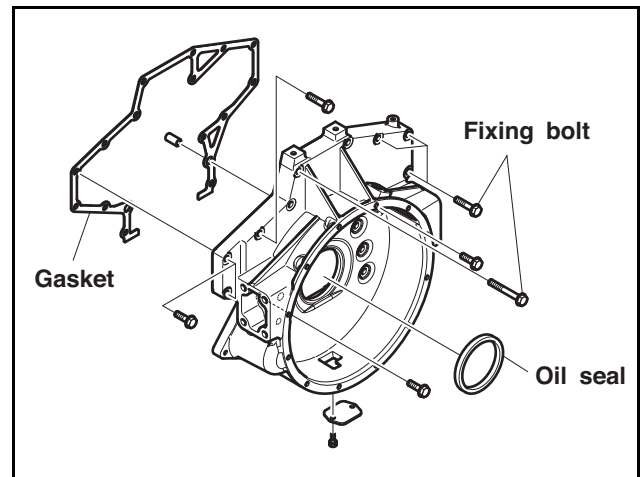

EK4OM018-E

- 1) Install a guide bar to the cylinder block temporarily.
  - 2) Install the gasket to the cylinder block.
  - 3) Use a dowel pin and guide bar to install the flywheel housing.
  - 4) Tighten the mounting bolts to 11.2 kg·m in the specified order.
  - 5) Remove the guide bar.
  - 6) Apply a thin film of engine oil to the outer surface of the oil seal and fit this seal into the flywheel housing.
10. Install the rear oil seal.

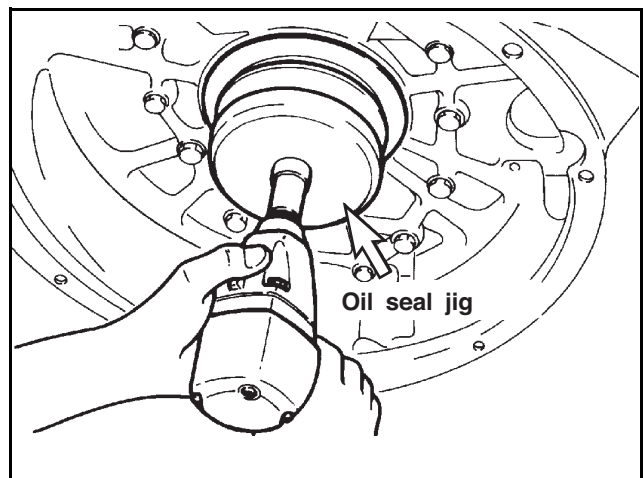

EA8M3003-E

- 1) Align the oil seal with the crankshaft.
- 2) Install the oil seal using its jig.



## 5. About the engine

11. Install the flywheel.

- 1) Heat the ring gear with a gas burner evenly to expand it. Then, install it with a hammer.

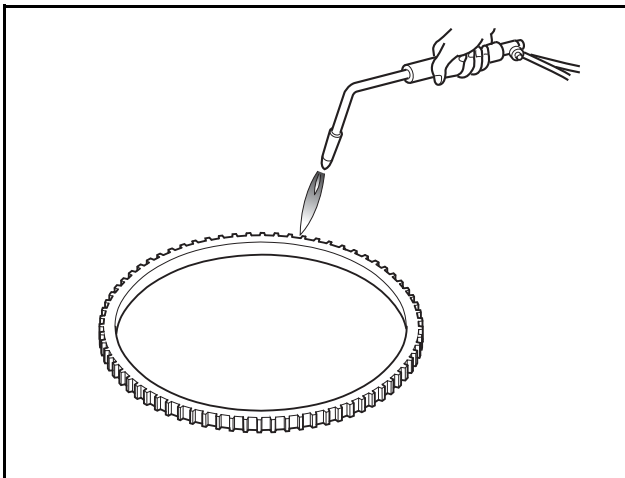

EA0M4029

### **⚠ CAUTION**

- Make sure that the temperature of the ring gear does not exceed 200°C.
- When installing the wear ring, heat it to 150°C with a heater, and apply LOCTITE #262 to it, and use an assembly jig to install it.

- 2) The FRONT of the wear ring can be identified by the mounting surface on the outer skirt.

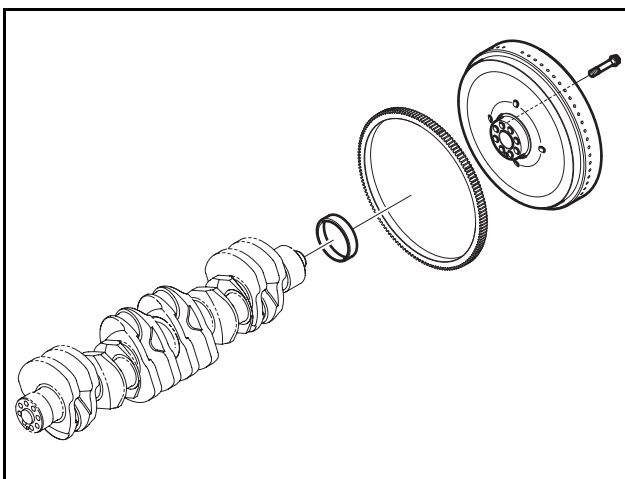

EK40M019

- 3) Fit a guide bar into the crankshaft bolt hole.
- 4) Align the flywheel with the reference pin to install it temporarily.
- 5) Apply adhesive (LOCTITE #587) to the mounting bolt.
- 6) Fit the bolts that have no guide pin in their holes. Then, remove the guide pin and fit the remaining bolt.

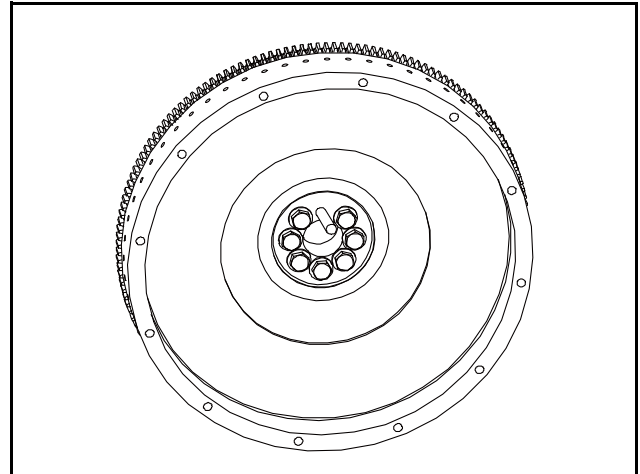

EE10M080

- 7) Tighten the bolts (M14 x 1.5) to 20 kg·m in the specified order.

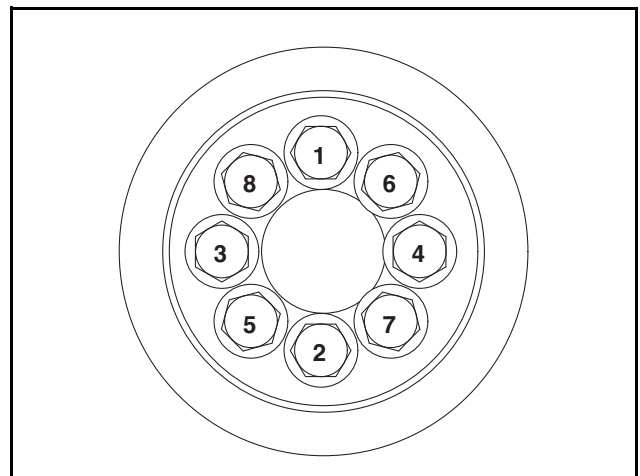

EE10M081

12. Install the piston and connecting rod.

- 1) Heat the piston to approx. 100°C with a heater for 5 minutes.

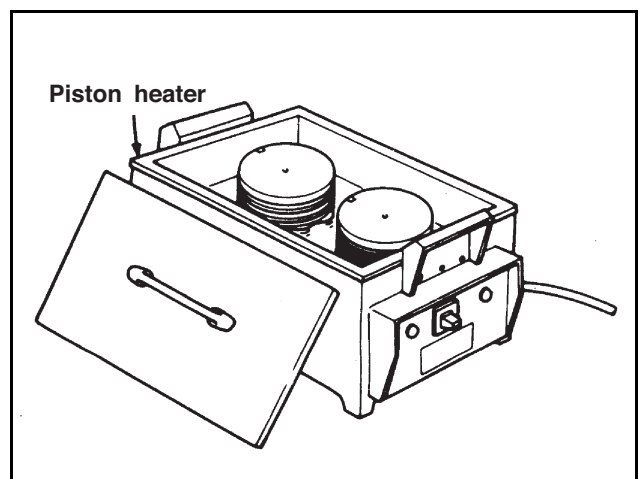

EA3M2058-E

## 5. About the engine

- 2) When installing the piston and connecting rod, the weight controlling section at the small end of the connecting rod and the oil gallery inlet (big hole side) of the piston should face the opposite direction.
- 3) Apply oil to the pin hole of the piston and align this hole with the small end of the connecting rod. Then, tap the piston pin with a rubber hammer gently to install the connecting rod and piston.

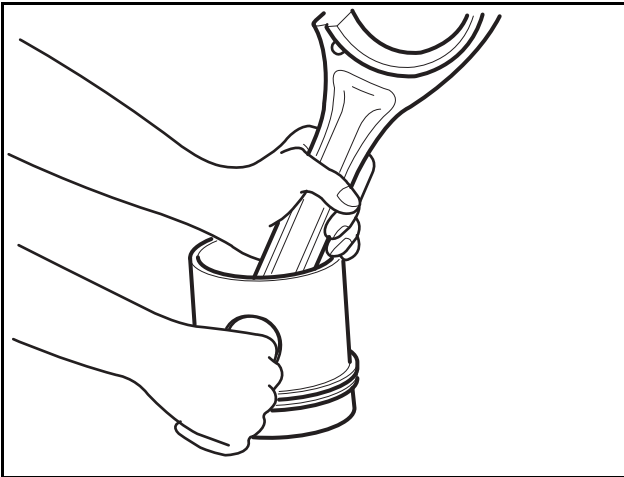

EAMD088I

- 4) The openings of the snap rings should be set in the opposite direction (upwards and downwards).

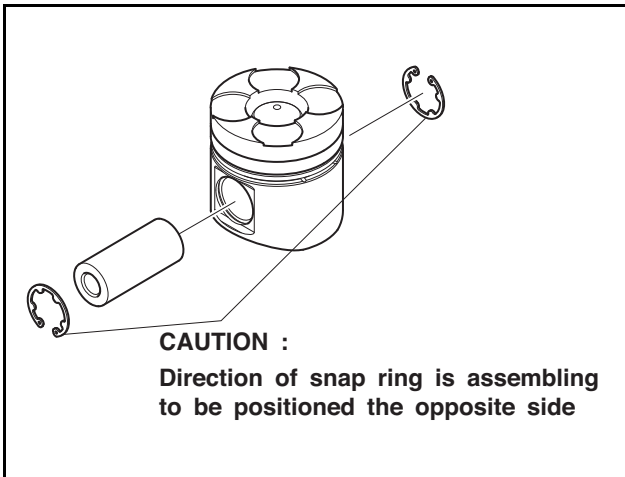

EE2OM072-E

- 5) Install the snap ring. Check its mounting condition.
- 6) Use piston ring pliers to install the piston ring to the piston.

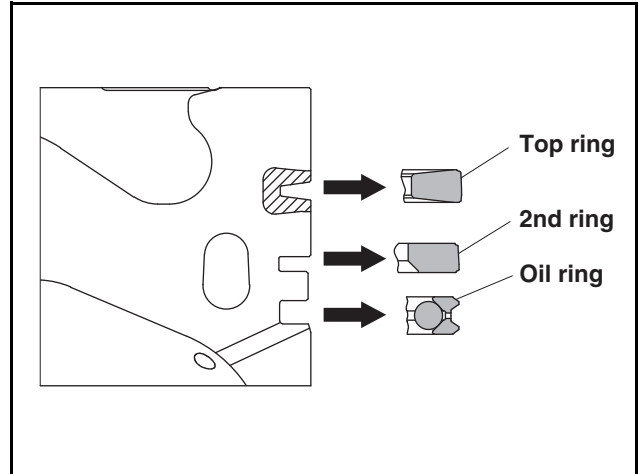

EDL06200008

- 7) Make sure to install the piston ring in the correct direction. The mark "Y" or "TOP" on the ring connection should face up.

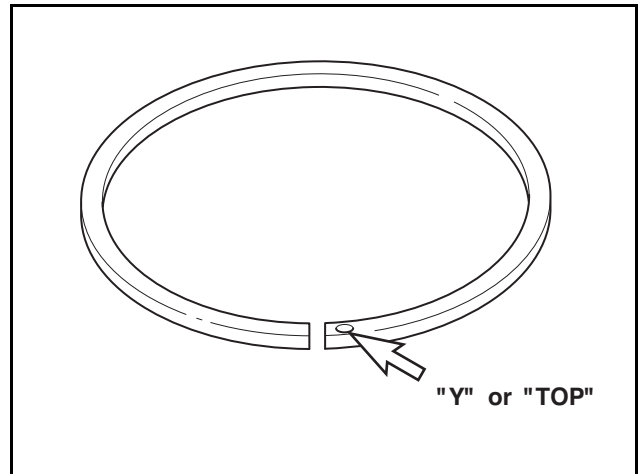

EAMD090I-E

- 8) Adjust each piston ring connection angle to 120° and fit a piston inserting jig into the piston.

### **⚠ CAUTION**

**The connection of the piston ring should not be in the same direction with the pin.**

## 5. About the engine

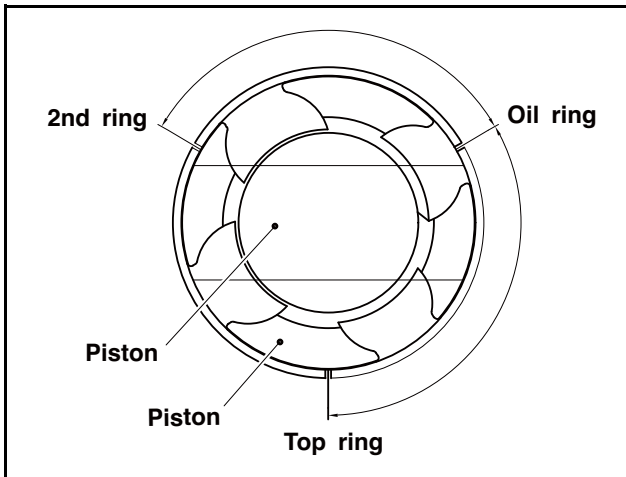

EE1OM083-E

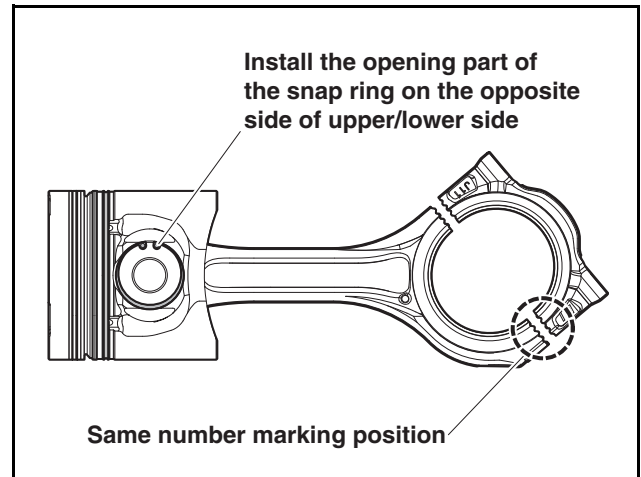

EDL06200018

- 9) Install the connecting rod bearing while aligning it with the key groove. Then, apply oil to the bearing and piston.
- 10) Fit the piston so that the oil gallery inlet of the piston is in the same direction with the spray nozzle.
- 11) Use a piston inserting tool to insert it into the cylinder liner. Be careful not to damage the ring by the tip of the liner.

### **CAUTION**

**Make sure that the cylinder liner and piston are not damaged.**

- 14) Install the connecting rod cap while aligning it with the reference pin.
- 15) Wipe oil from the mounting bolt and install the bolt loosely.
- 16) Tighten the bolts to the specified tightening torque in the specified order using a torque wrench.
  - Step 1: When installing connecting rod bolt, tighten the bolt with your hand until its head touches the bolt seats on both sides of the connecting rod.
  - Step 2: Tighten it to 2.85 ~ 3.15 kg·m with a torque wrench.
  - Step 3: Mark the head and left side of the bolt and then tighten the bolt 57 ~ 63 degrees more.

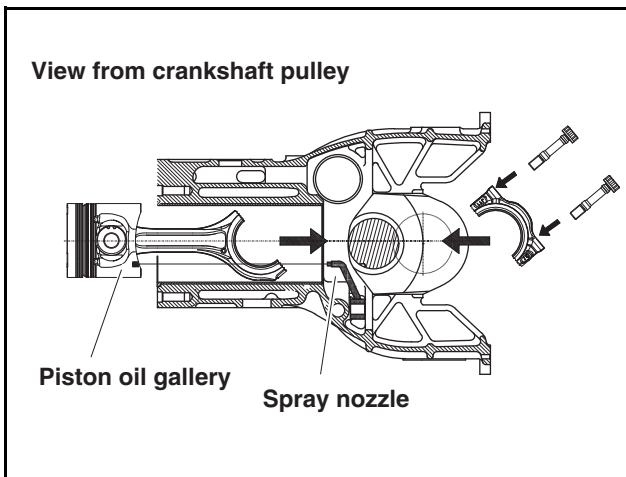

EDL06200017

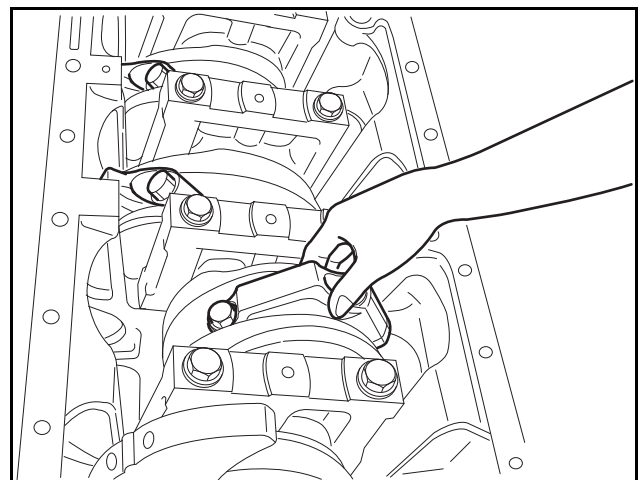

EAMD094I

- 12) Fit the bearing to the connecting rod cap and apply oil on it.
- 13) Check that the manufacturing serial numbers stamped on the connecting rod cap and connecting rod big end are the same.

## 5. About the engine

13. Install the oil pump and oil pipe.

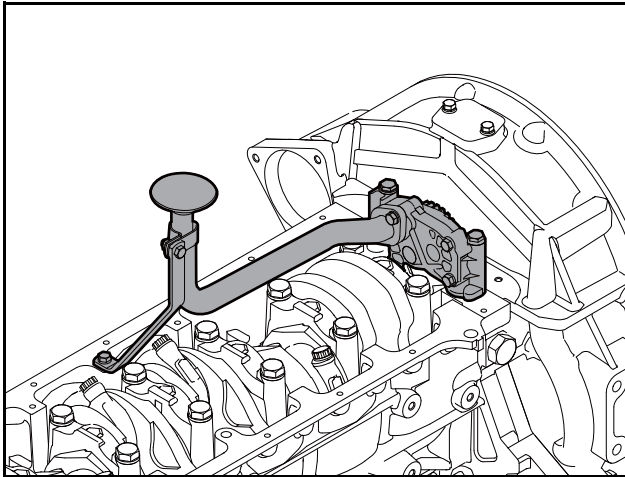

EK4OM059

- 1) Install the reference pin to the bearing cap No. 7.
  - 2) Tap the oil pump with a urethane hammer gently to install it.
  - 3) Fit the washer and tighten the mounting bolt (M8) to 2.2 kg·m. Tighten the bolt (M10) to 4.4 kg·m.
  - 4) Connect the oil feed pipe to the oil pump with the bolt.
14. Install the front oil seal.

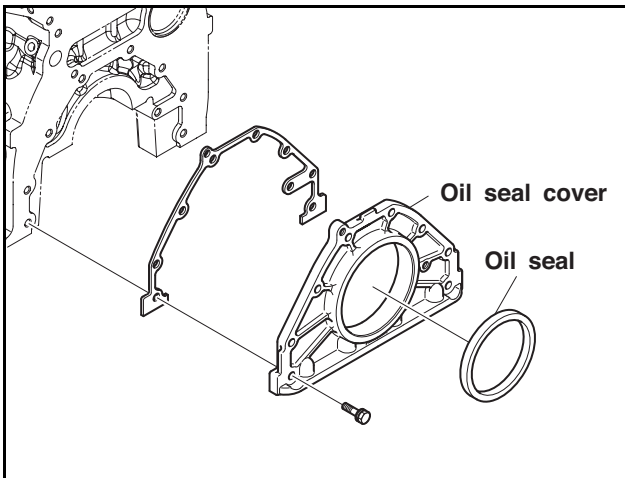

EK4OM077-E

- 1) Apply engine oil to the inside of the oil seal before installing the oil seal to the cover.
- 2) Align a new oil seal with the center of the hole on the oil seal cover.
- 3) Use an installing jig to install the oil seal.
- 4) Tighten it to 2.2 kg·m.

15. Install the oil pan.

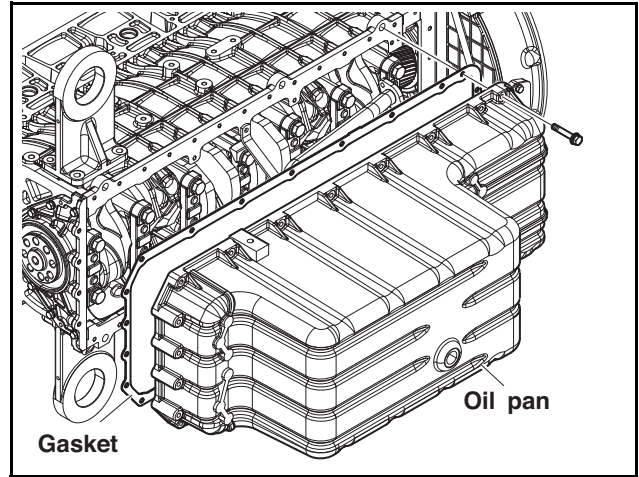

EJ9OM046-E

- 1) Remove any protruded gasket on the timing gear case, cover, cylinder block and flywheel housing contact surface with a scraper thoroughly.

### CAUTION

**Make sure any gasket does not enter the engine during work.**

- 2) Apply silicon on the surfaces where the used gasket was removed. Then, attach a new oil pan gasket.
- 3) Install the oil pan.
- 4) Tighten the bolts (4 EA) on both ends of the oil pan first and tighten the remaining bolts.
- 5) Tighten the oil pan mounting bolt to 2.2 kg·m.

### CAUTION

**Align the bolt holes with the gasket holes before tightening the bolts.**

- 6) Tighten the drain plug to 10 kg·m.

## 5. About the engine

16. Install the crankshaft pulley and vibration damper.

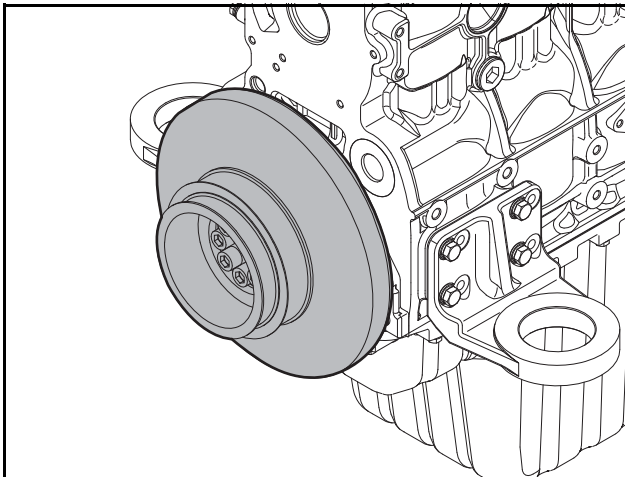

EK4OM051

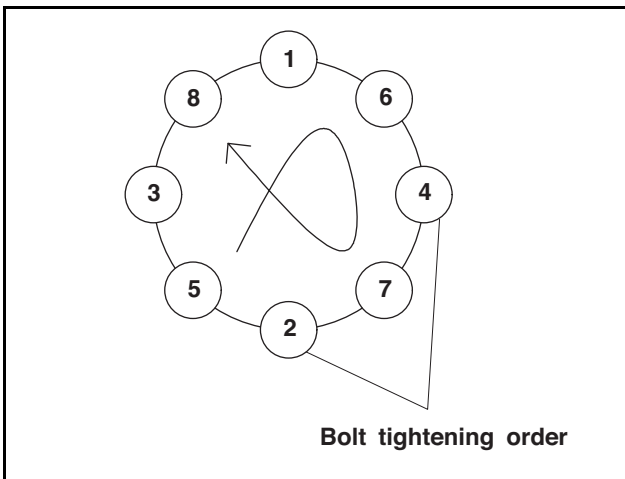

EE1OM155-E

- 1) Install the vibration damper to the crankshaft pulley.
- 2) Tighten the bolts in the correct order.
- 3) Tighten the vibration damper to 6.2 kg·m.
- 4) Tighten the crankshaft pulley to 20 kg·m.

17. Install the intake and exhaust valves.

- 1) Before installing the valve to the cylinder head, check the marks "I" and "E" on the valve head surface.

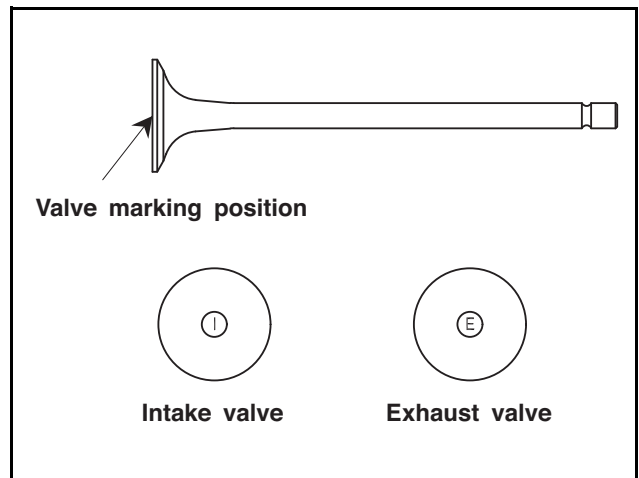

EE1OM156-E

- 2) Use a valve stem seal installing jig to install the valve stem seal to the valve guide.
- 3) Install the valve cotter by pressing the retainer with a valve spring compressing tool after installing the valve spring and retainer.

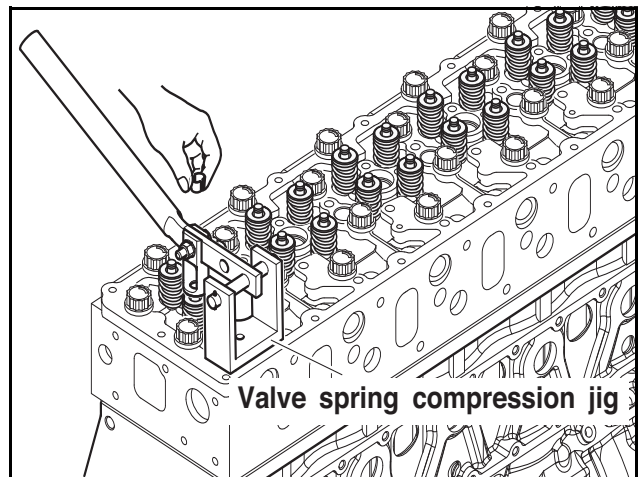

EG9OM078-E

- 4) Tap the valve stem with a rubber hammer gently to check if the valve is corrected installed.

18. Install the cylinder head.

- 1) Blow compressed air through the bolt hole of the cylinder head to remove any foreign materials.
- 2) Clean the gasket mating surface of the cylinder head thoroughly.

### **⚠ CAUTION**

**Ensure that no foreign material enters the combustion chamber.**

## 5. About the engine

- 3) Align the new gasket bolt hole with the reference pin on the cylinder block.
- 4) When installing the gasket, its mark on the right should be upwards.

### **⚠ CAUTION**

Replace the gasket with a new one.

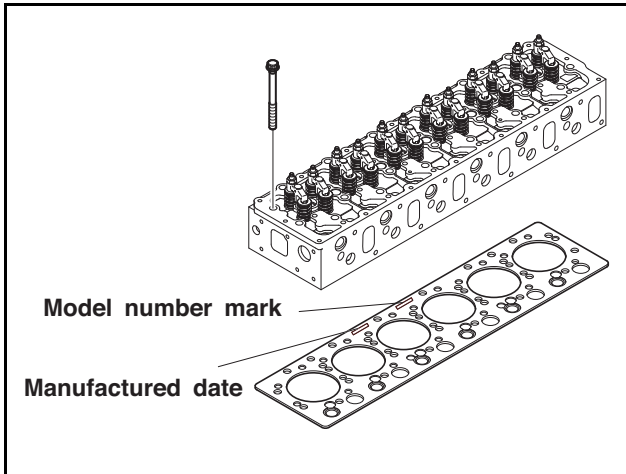

EK4OM002-E

- 5) Check if there is any foreign material in the combustion chamber.
- 6) Install the cylinder head by aligning it with the retaining pin.

### **⚠ CAUTION**

- Be careful not to damage the gasket.
- If the pin hole cannot be aligned, lift the head and then try to seat it again.

- 7) Install the cylinder head bolt.

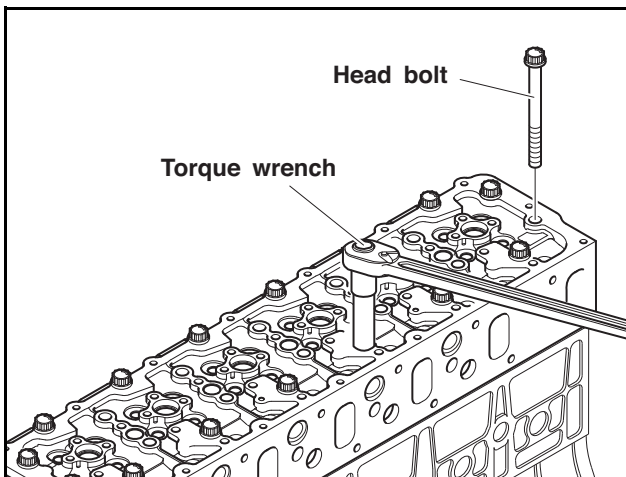

EE1OM052-E

- 8) Tighten the cylinder head bolts to the specified tightening torque in the specified order.

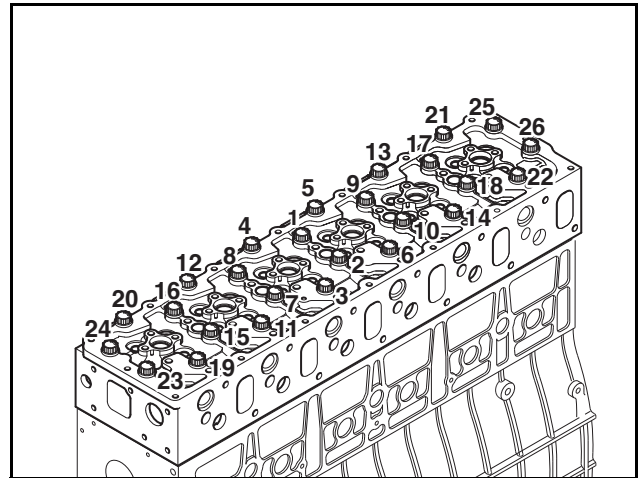

EE1OM087

- Step 1: Tighten it for 1 to 2 threads with a hand, and then tighten it to 4 kg·m temporarily.
- Step 2: Tighten it to 5 kg·m with a torque wrench.
- Step 3: Tighten it for 90° with a torque wrench.
- Step 4: Tighten it for 90° with a torque wrench.
- Step 5: Tighten it for 90° with a torque wrench for the final time.

### **⚠ CAUTION**

All the bolts should be tightened according to the above steps.

19. Install the push rod.

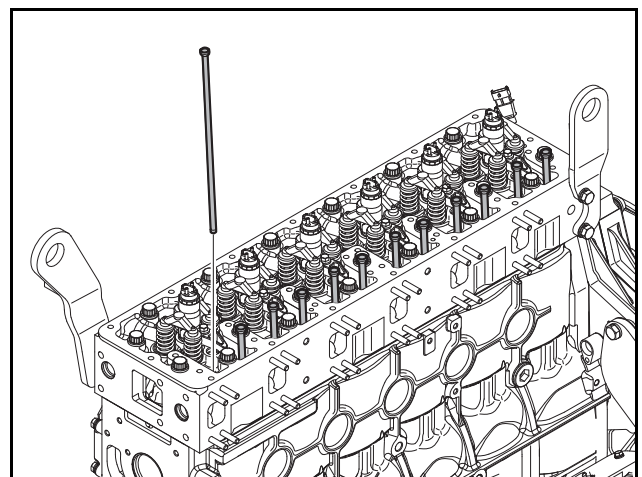

EK4OM054

- 1) Apply engine oil to the push rod.
- 2) Insert the push rod into the push rod hole of the cylinder head.

20. Install the injector.

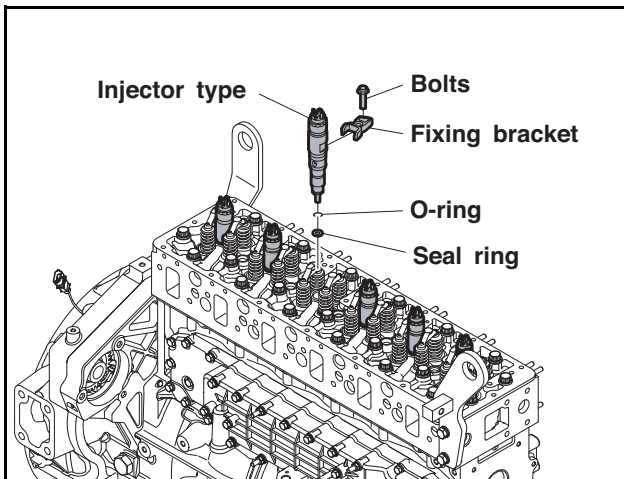

EK4OM055-E

### **⚠ CAUTION**

- When you replace the fuel injection pipe on the high-pressure fuel connector (HPC) with a new one, make sure to re-tighten the HPC mounting nut to the specified torque.  
And do not reuse the injection pipe because it seals high-pressure fuel by getting plastically deformed when tightened.
  - HPC nut tightening torque:  $5.3 \pm 0.3$  kg-m
  - Injection pipe tightening torque:  $4.0 \pm 0.4$  kg-m
- Clean all parts thoroughly and make sure that no foreign material enters any part.
- Especially, the fuel line between the common rail and injector is not equipped with a filtering function. Therefore, this section should be kept clean with care.
- Clean the drilling of the head for the fuel high-pressure connector and the hole for the injector thoroughly to remove any foreign materials from them.
- If the injector is removed, the fuel high-pressure connector should be replaced with a new one.
- If fuel collected in the fuel return line enters the combustion chamber during injector disassembly process, remove fuel by sucking it out with a hand pump or by cranking the engine with fuel flow blocked.

## 5. About the engine

- 1) Install the injector correctly according to the following steps:

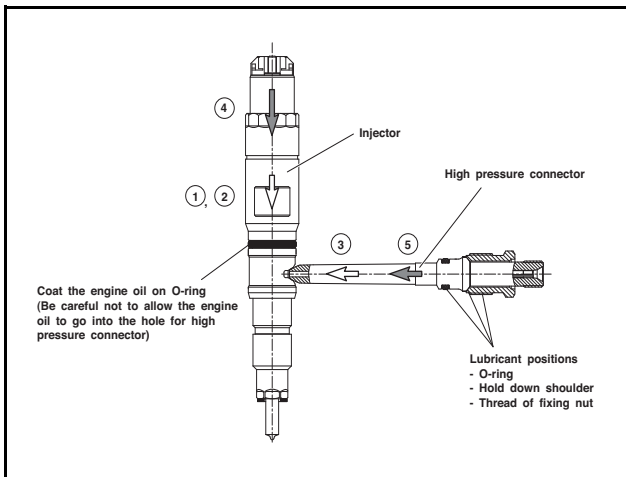

EG9OM130-E

- 2) Fit the O-ring to the injector and apply engine oil to the outer circumference surface.

### **CAUTION**

**Make sure that oil or foreign material is not on the fuel high-pressure connector hole on the side of the injector.**

- 3) Align the seal ring with the injector hole on the cylinder head. Then, insert the injector gently.
- 4) Align the injector mounting bolt with the thread of the head. Then, tighten the bolt for 2 - 3 threads with a hand.
- 5) Set the injectors to the mounting positions of the injector mounting brackets (1 & 2) with the mounting bolts. Then, tighten them temporarily.

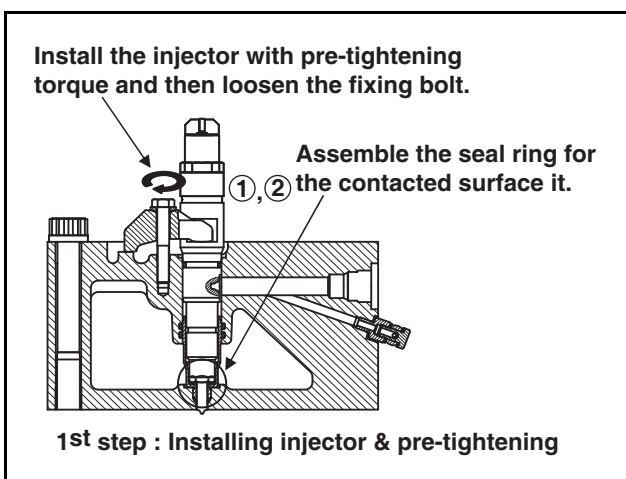

EG9OM131\_1E

- 6) After tightening the injectors temporarily, unscrew the bolts of the mounting brackets enough to move the injectors freely without load.

- 7) Set the fuel high-pressure connector (3) with its balls set vertically.

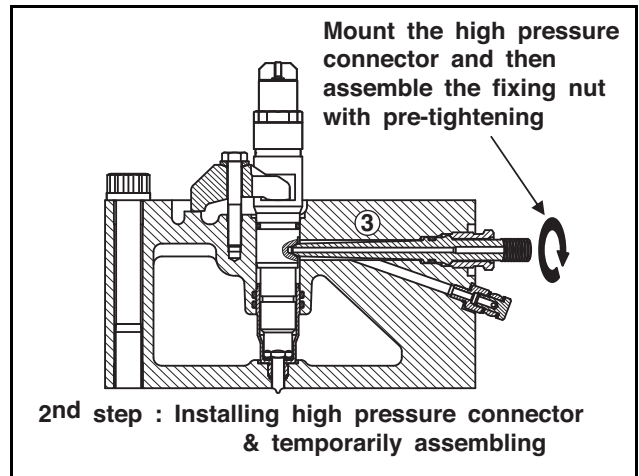

EG9OM131\_2E

- 8) Ensure that it is aligned with the groove in the hole on the side of the head on the intake manifold side.
- 9) Align the fuel high-pressure connector through the hole on the side of the head, and push in the fuel high-pressure connector enough.
- 10) Tighten the mounting nut (M22 x 15) of the fuel high-pressure connector for 2 - 3 threads with a hand.
- 11) Tighten the injector mounting bracket bolt to 0.3 kg·m with a torque wrench.
- 12) Tighten the injector mounting bracket bolt to 1.5 + 0.5 kg·m using a torque wrench.
- 13) Tighten the injector mounting bracket mounting bolt (4) to 3.1 - 3.5 kg·m,

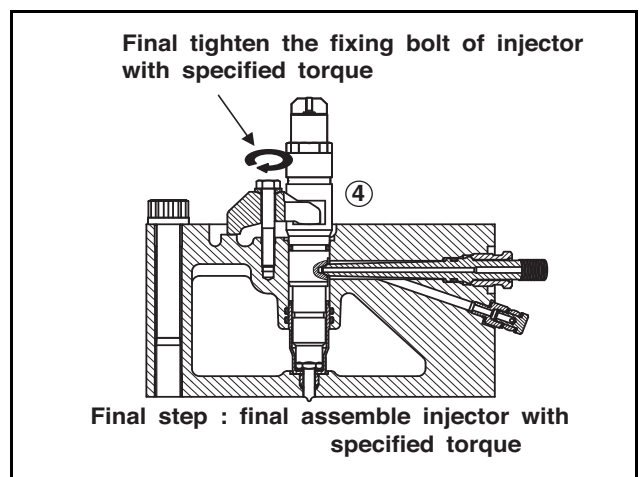

EG9OM132\_1E



## 5. About the engine

- 14) Tighten the fuel high-pressure connector mounting nut (5) to 5 - 5.5 kg·m.

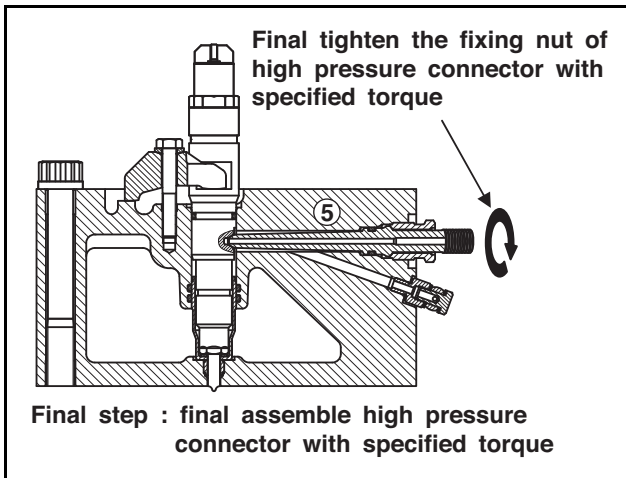

EG9OM132\_2E

21. Install the rocker arm.

- 1) For rocker arm assembly, install the spring, rocker arm, bracket, rocker arm, spring, washer and snap ring in order.

### ⚠ CAUTION

Install the rocker arm and bracket in the same direction.

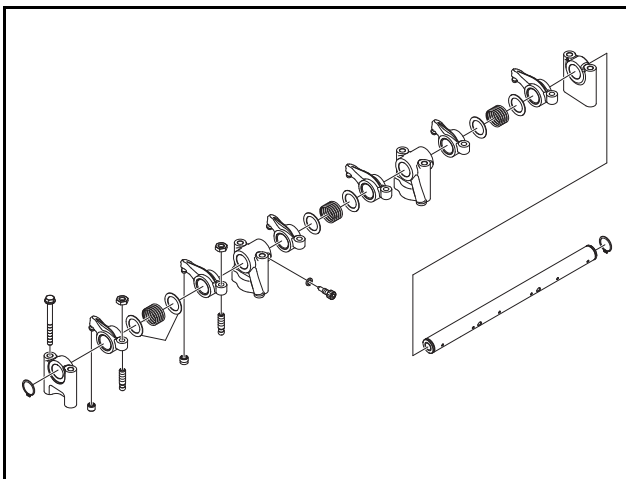

EK4OM021

- 2) Apply oil to the rocker arm bushing and shaft.
- 3) Use the mounting bolts to install the rocker arm and bracket onto the cylinder head.
- 4) Tighten the bolts to 3.75 kg·m diagonally.
- 5) Install the valve clearance adjusting screw to the rocker arm temporarily.

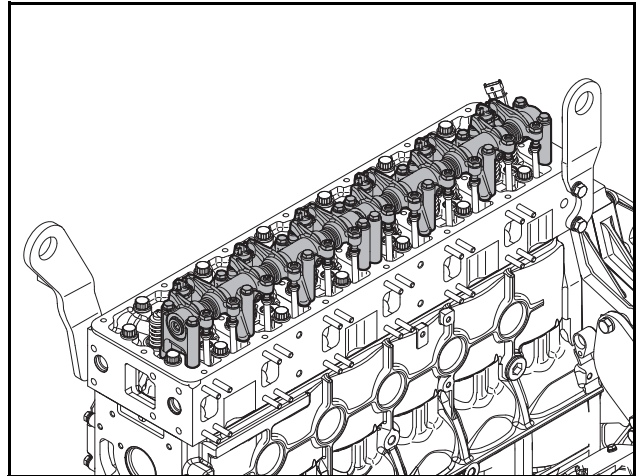

EK4OM053

- 6) Adjust the valve clearance.
22. Install the intermediate cover.

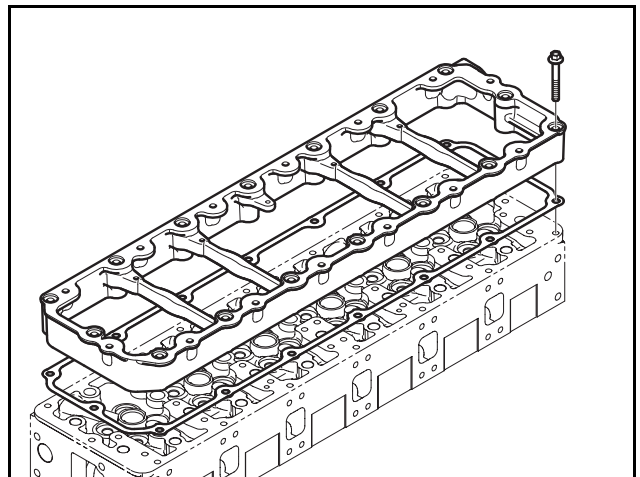

EK4OM022

- 1) Install a new gasket to the intermediate cover.
- 2) Tighten the mounting bolt to 3.1 kg·m.
23. Install the cylinder head cover.

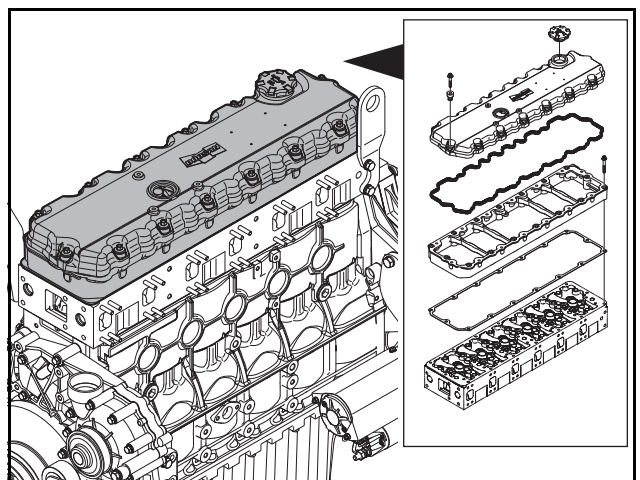

EK4OM003

- 1) Install a new rubber gasket to the cylinder head cover.
- 2) Install the cylinder head cover to the cylinder head.

## 5. About the engine

- 3) Tighten the mounting bolt to 2.2 kg·m.
  - 4) Install the oil filler cap to the cylinder head cover.
24. Install the oil cooler.

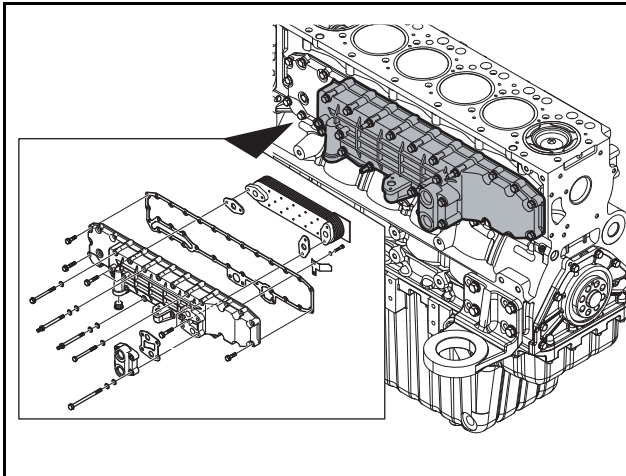

EK4OM078

- 1) Install the oil cooler and gasket to the cylinder block.

### CAUTION

Make sure to install the gasket in the correct direction.

- 2) Tighten the bolt to 2.2 kg·m.
25. Install the oil filter.

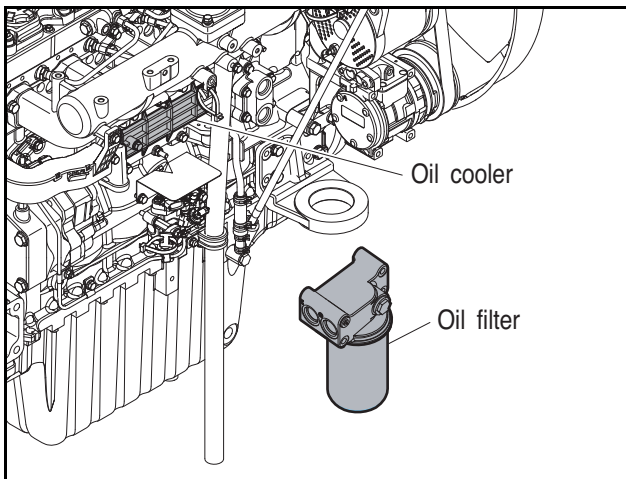

EK4OM041-E

- 1) Install the oil filter cartridge using a special service tool.

### CAUTION

The oil filter should be installed to the engine without oil in it. Never fill the new oil filter with oil drained from the used oil filter.

26. Install the coolant pump.

- 1) Install the coolant pump cover and coolant pump gasket.

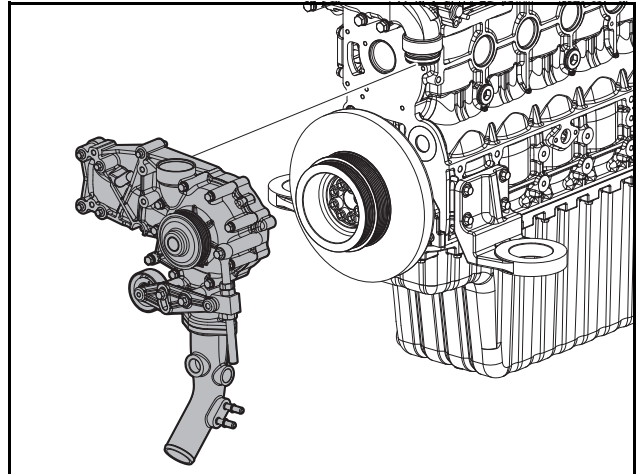

EDL06200016

- 2) Install the coolant pump to the cylinder block.

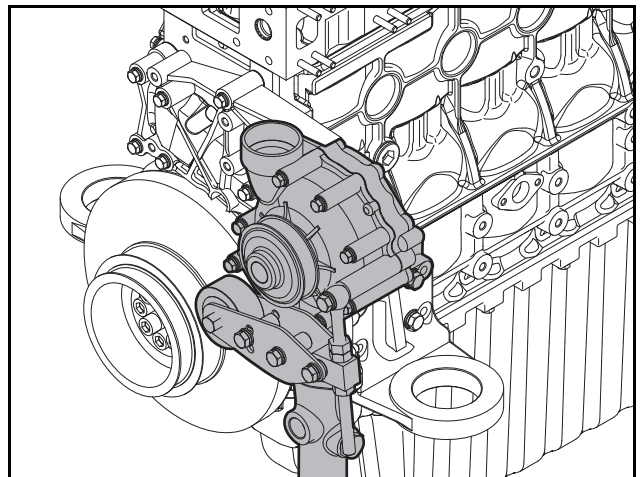

EK4OM049

- 3) Tighten the mounting bolt to 2.2kg·m.
  - 4) Install the idle pulley bracket.
27. Install the start motor.

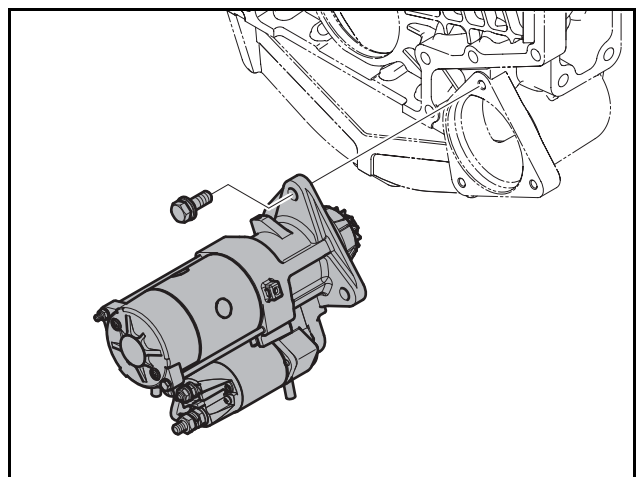

EK4OM079

- 1) Install the start motor to the stud bolt of the flywheel housing.
- 2) Tighten the mounting nut to 8.0 kg·m.

## 5. About the engine

28. Install the common rail and high-pressure pipe.

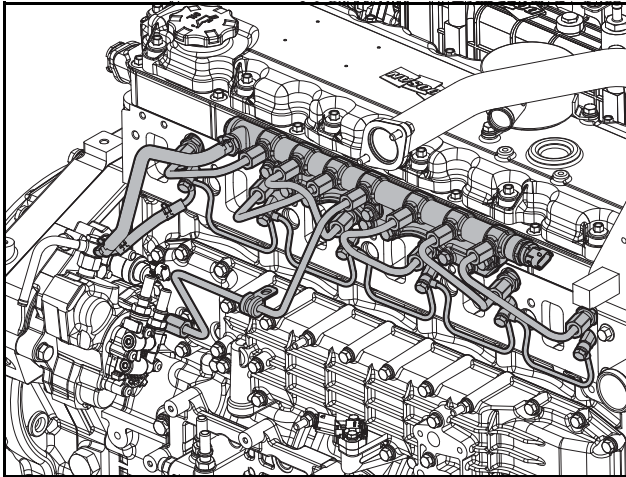

EDL06200021

- 1) Install the common rail to the cylinder block.
- 2) Connect the fuel feed pipe between the common rail and fuel high-pressure connector.
- 3) Tighten the fuel high-pressure pipe on the common rail side to 2.5 kg·m.
- 4) Tighten the fuel high-pressure pipe on the fuel high-pressure connector side to 2.8 kg·m.
- 5) Tighten the common rail fuel high-pressure pipe from the fuel high-pressure pump to 2.1 kg·m.
- 6) Tighten the common rail mounting bolt to 2.2 kg·m.

### ⚠ CAUTION

- Never reuse the fuel high-pressure pipe.
- Tighten the fuel high-pressure pipe to the specified torque for a cylinder by cylinder.

29. Install the intake manifold.

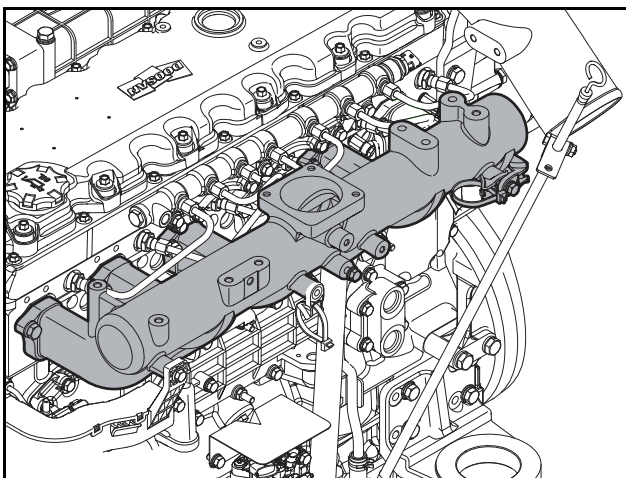

EK40M045

- 1) Install a new gasket between the cylinder head and intake manifold.
- 2) Tighten the mounting bolt to 4.4 kg·m.

30. Install the exhaust manifold.

- 1) Install the exhaust manifold gasket to the stud bolt of the cylinder head.

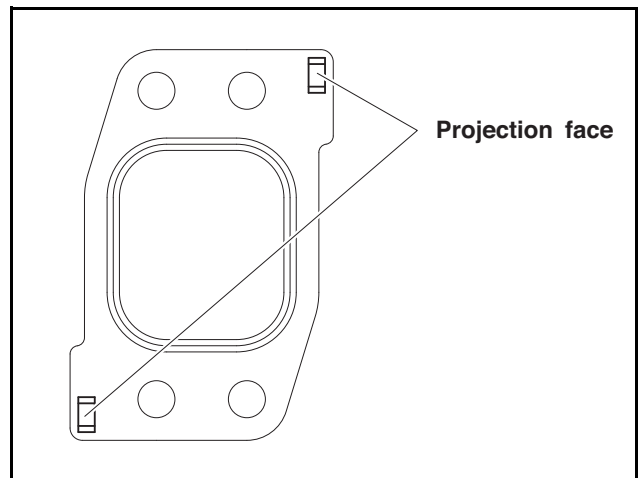

EG90M112-E

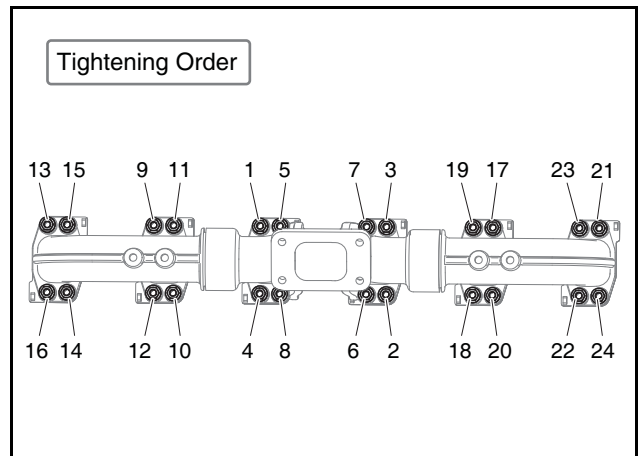

EDL06180021

- 2) Align the gas outlet of the cylinder head with the gasket hole.
- 3) Install the exhaust manifold.

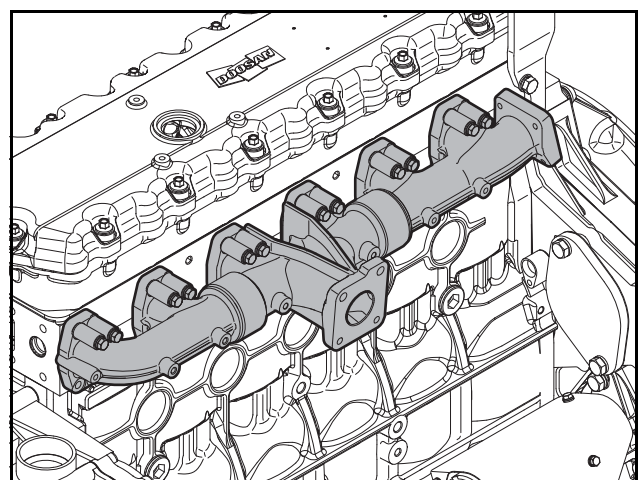

EK40M020

- 4) Tighten the mounting bolt to 2.8 ± 0.28 kg·m → 90° Loose → 3.5 kg·m.

## 5. About the engine

31. Install the turbocharger.

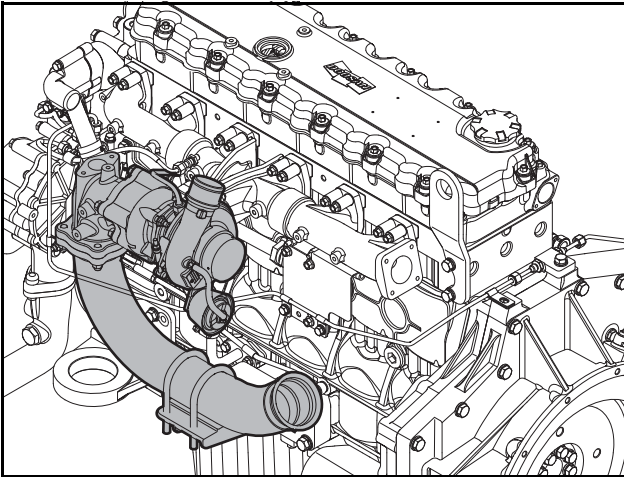

EK4OM048

- 1) Install a new gasket to the stud bolt of the exhaust manifold.
- 2) Install the turbocharger.
- 3) Connect the oil feed pipe and drain pipe.
- 4) Tighten the clamp for the rubber hose to connect the air pipe and turbocharger.
- 5) Tighten the mounting bolt to  $6.5 \pm 0.65 \text{ kg}\cdot\text{m}$ .

32. Install the coolant pipe and thermostat.

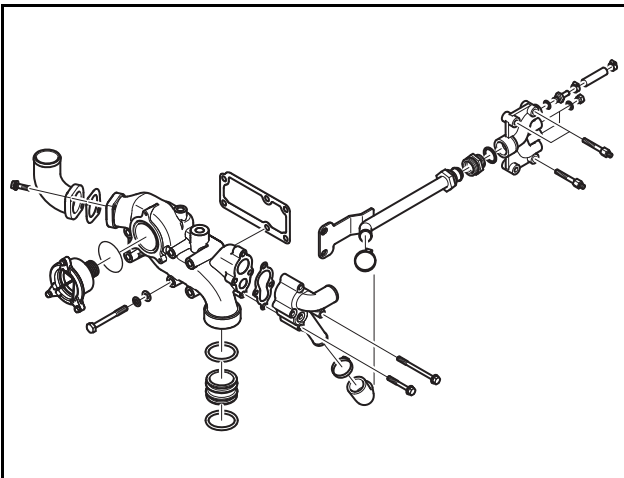

EK4OM074

- 1) Install the gasket to the cylinder head.
- 2) Install the housing to the thermostat.
- 3) Install the O-ring to the thermostat.
- 4) Connect the coolant pipe.
- 5) Tighten the bolt to  $2.2 \text{ kg}\cdot\text{m}$ .

33. Install the HC (HydroCarbon) injector.

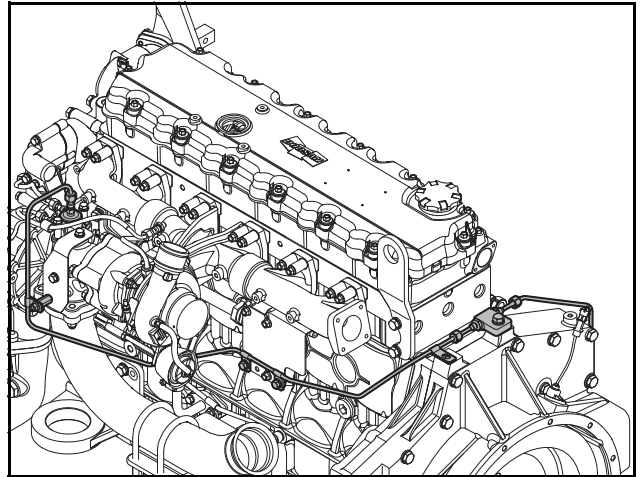

EK4OM038

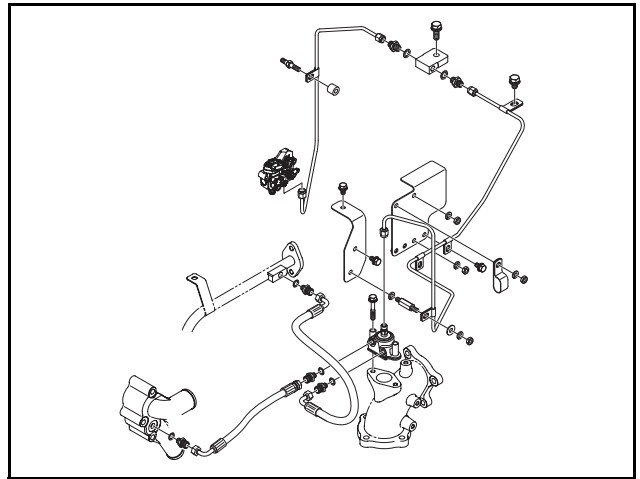

EK4OM098

- 1) Install the HC injector to the exhaust pipe with its mounting bolts.
  - 2) Install the cooling hose to the HC injector.
  - 3) Connect the HC injection pipe.
34. Install HC dosing metering unit.

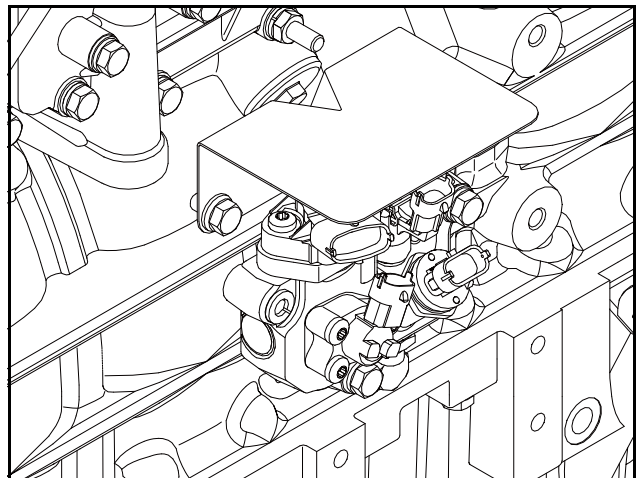

EK4OM106

- 1) Install the HC dosing metering unit to the bracket with the mounting bolts.

## 5. About the engine

- 2) Install the cover for the HC dosing metering unit with the mounting bolts.
- 3) Connect the HC dosing pipe.
35. Install the EGR cooler.

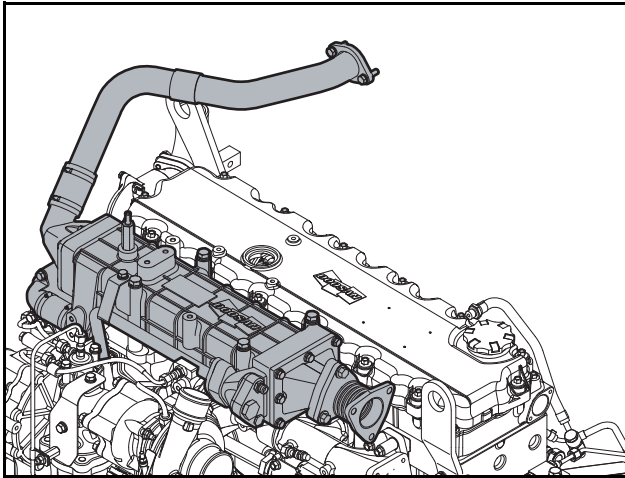

EK4OM037

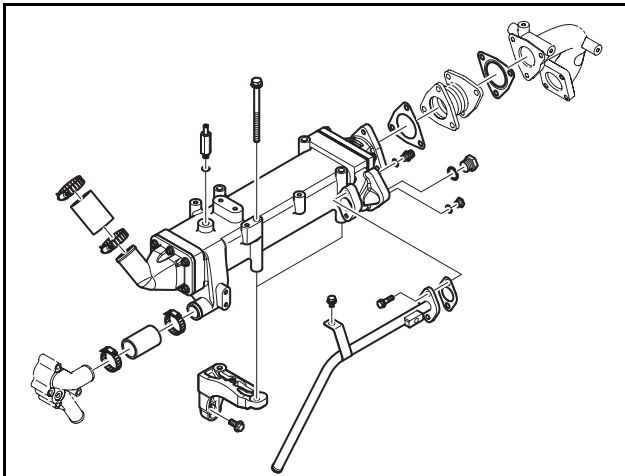

EK4OM072

- 1) Install the EGR cooler mounting bracket to the cylinder head with the mounting bolts.
- 2) Install the EGR cooler to the bracket with the mounting bolts.
- 3) Connect the pipe and hose to the EGR cooler.

### CAUTION

**Do not reuse the gasket.**

36. Install the EGR valve.

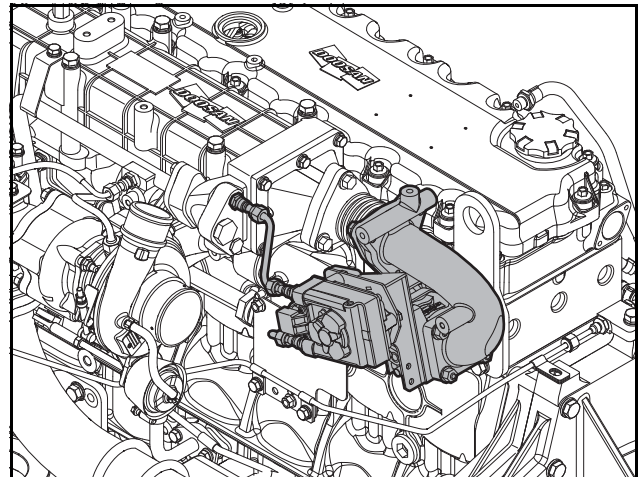

EK4OM036

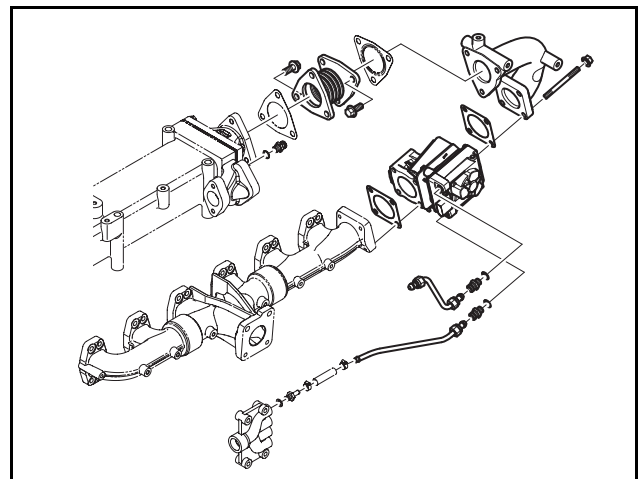

EK4OM080

- 1) Install the exhaust pipe to the EGR cooler with the gasket and secure it with the mounting bolt.
- 2) Install the EGR valve to the exhaust pipe with the gasket and secure it with the mounting bolt.

### CAUTION

**Do not reuse the gasket.**

## 5. About the engine

37. Install the ECU (Electrical Control Unit).

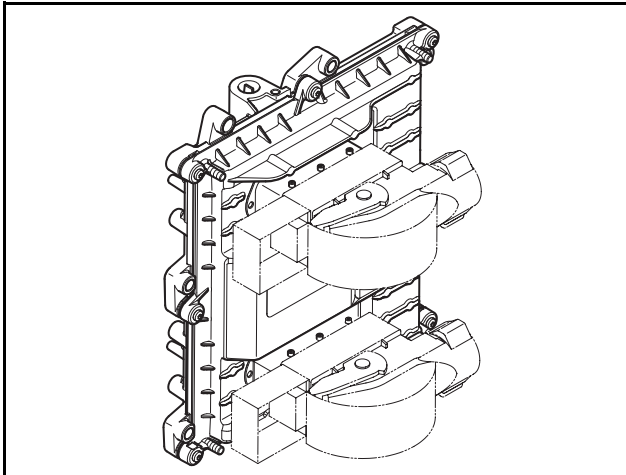

EK4OM023

- 1) Fix the ECU mounting plate.
- 2) Install the ECU.

38. Install the crankshaft speed sensor and camshaft speed sensor.

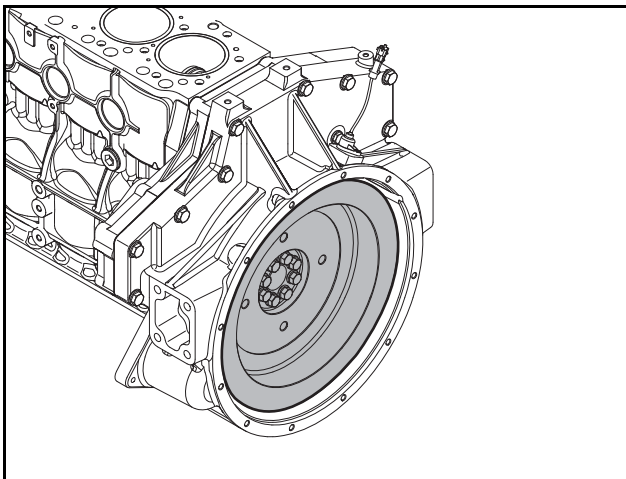

EK4OM060

- 1) Measure the clearance between the mounting section of the crankshaft speed sensor and flywheel. Use shims to adjust this clearance to 1.0 mm.
- 2) Tighten the crankshaft speed sensor to 1.0 kg·m.
- 3) Measure the clearance between the mounting section of the camshaft speed sensor and timing gear. Use shims to adjust this clearance to 1.0 mm.
- 4) Tighten the camshaft speed sensor to 1.0 kg·m.

39. Install the fuel filter.

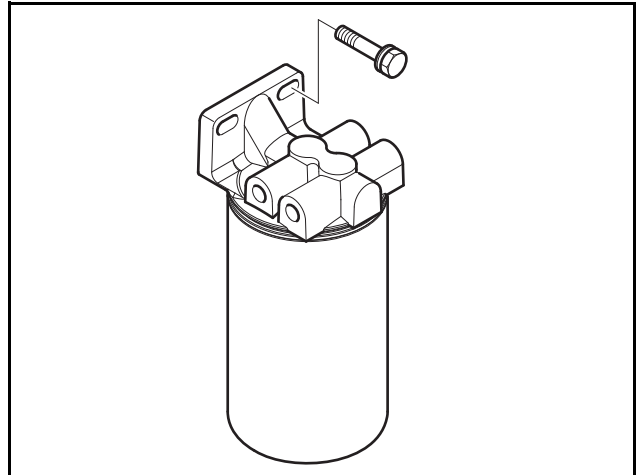

EJ9OM081

- 1) Fuel needs to flow through the following components in this order: fuel feed pump, fuel filter, fuel high-pressure pump and common rail. Connect the fuel feed pipe correctly according to the arrow direction mark on the head of the fuel filter to ensure correct fuel flow.
- 2) Tighten the fuel pipe to 3.0 kg·m.
- 3) Tighten the fuel temperature sensor to 2.2 kg·m.
- 4) Tighten the mounting bracket to 4.4 kg·m.

### **⚠ CAUTION**

**A new fuel filter should be installed without fuel in it. Never add fuel in the used fuel filter or fuel tank to a new fuel filter.**

40. Install the alternator and belt.

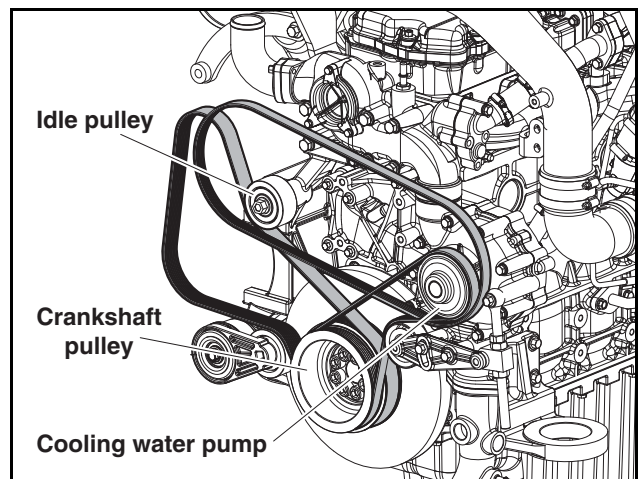

EDL06200015

- 1) Install the alternator and A/C bracket. Then, secure them with the mounting bolts.
- 2) Install the alternator, A/C compressor and idle pulley.
- 3) Tighten the alternator mounting bolt to 7.7 kg·m.
- 4) Tighten the alternator support mounting bolt to 5.0 kg·m.

## 5. About the engine

- 5) Install the belt and adjust its tension with its adjusting bolt.
41. Connect the air pipe and install the air heater.

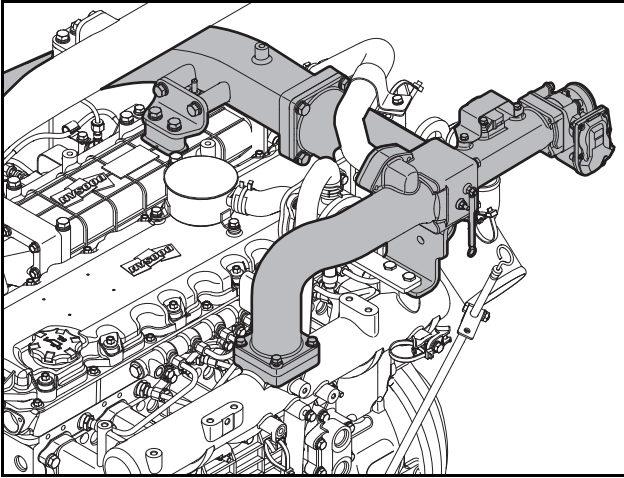

EK4OM044

- 1) Install the air pipe, air heater and throttle valve.
- 2) Tighten the mounting bolt to 2.2 kg-m.

### CAUTION

**Never let foreign materials enter the turbocharger.**

42. Install the cooling fan.

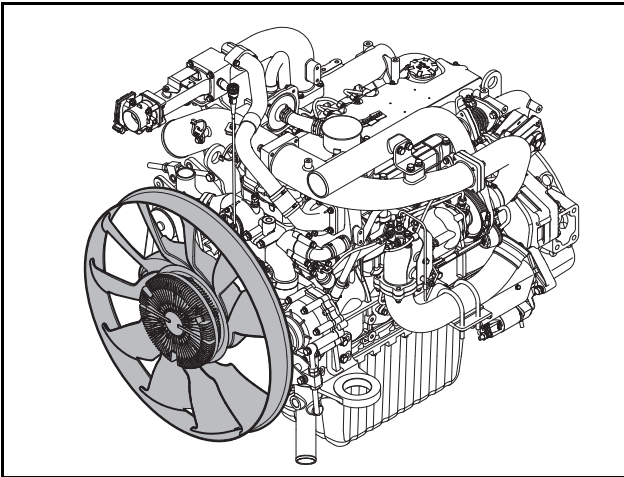

EK4OM012

- 1) Install the fan flange to the coolant pump pulley.
- 2) Install the cooling fan.
- 3) Tighten the cooling fan bolt to 2.2 kg-m.
- 4) Tighten the fan drive to 4.4 kg-m.

43. Fit the dipstick.

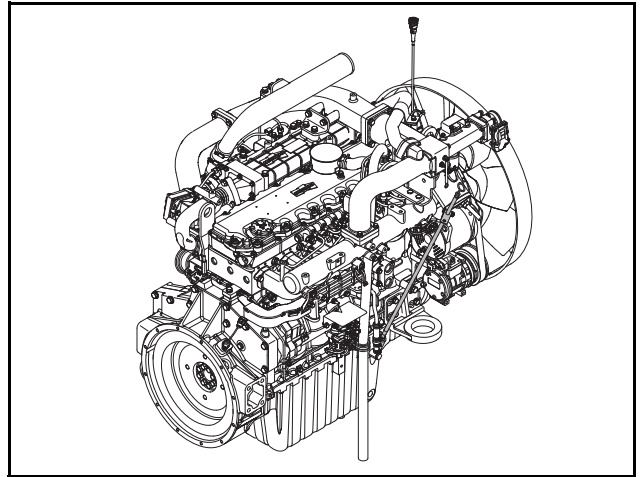

EK4OM082

- 1) Apply adhesive (LOCTITE #262) to the guide tube.
  - 2) Install the guide tube and dipstick to the oil pan.
44. Connect the cables and harnesses of the engine to each sensor.
  45. Mount the engine to the machine.
  46. Add engine oil.
  - 1) Open the oil filler cap on top of the cylinder head cover and add engine oil to it.

### CAUTION

**Make sure to use the recommended genuine oil.**

47. Add coolant.
- 1) Open the radiator cap and add coolant.

### CAUTION

**Make sure to use the recommended coolant.**

## 5. About the engine

---



# 6. Cooling system

General information .....	131
General information .....	131
Failure diagnosis.....	132
Thermostat .....	133
General information .....	133
Cautions for replacement and handling of thermostat .....	133
Thermostat inspection.....	133
Cooling fan .....	134
General information .....	134



### General information

#### General information

This engine is a water-cooled type. Combustion heat from the combustion chamber and heat from engine oil are absorbed by coolant and dissipating them to the outside air to ensure optimum engine operation.

In the cooling system, coolant supplied from the coolant pump is sent to the oil cooler through the coolant pipe to absorb heat from oil before it passes through the coolant jacket of the cylinder block and through the cooling passage of the cylinder head to absorb combustion heat.

After this coolant absorbs oil heat and combustion heat, it is led to the thermostat through the coolant pipe. If the coolant temperature is below the valve opening temperature of the thermostat, the coolant flows into the coolant pump. If the temperature is over the opening temperature, it flows into the radiator. In the radiator, it releases heat and returns back to the coolant pump in a low temperature condition again.

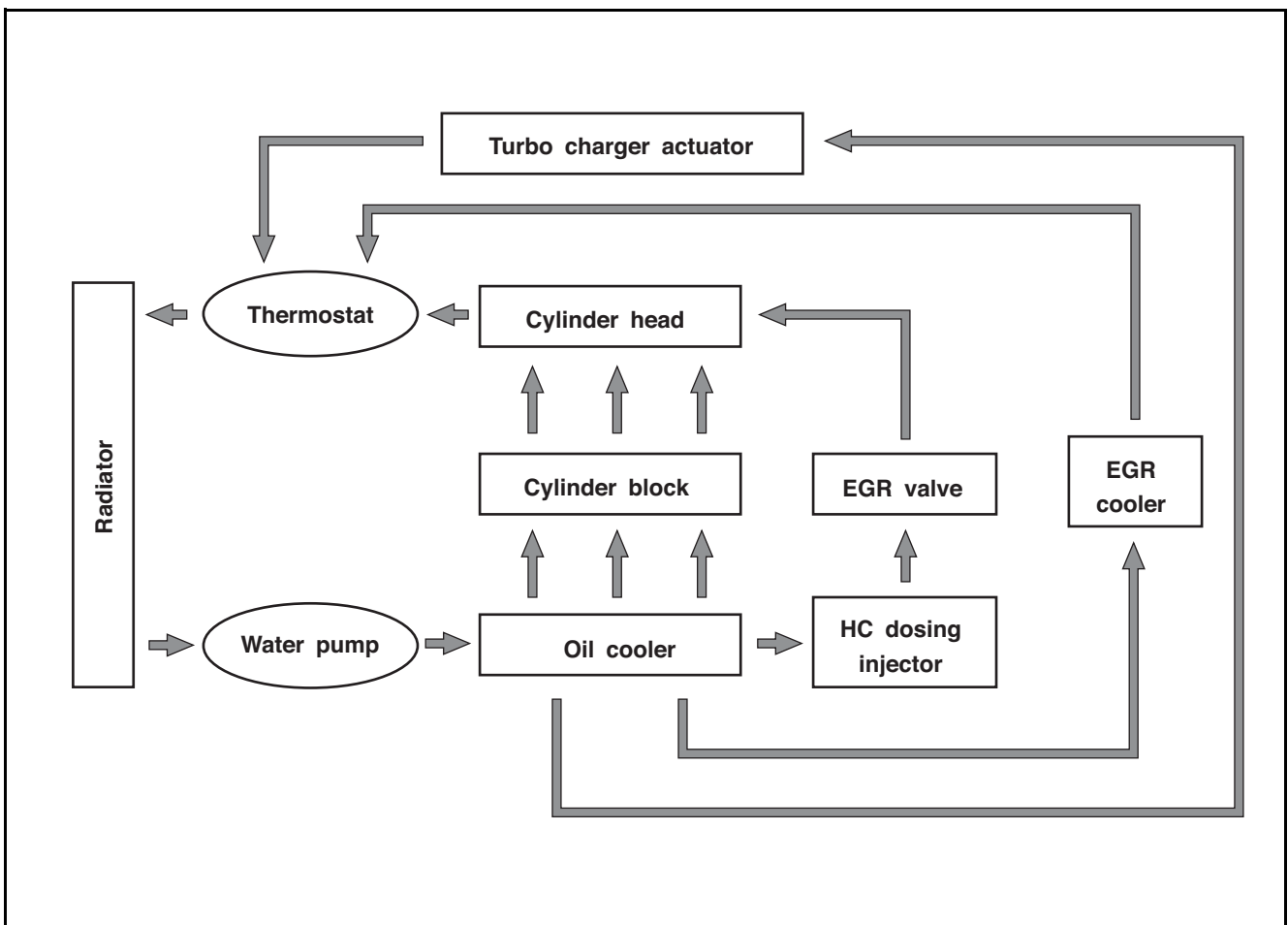

EK10M072

## 6. Cooling system

### Failure diagnosis

Phenomenon	Causes	Troubleshooting
Overheated engine	Not enough coolant	Replenish the coolant
	Defective radiator cap	Replace it
	Contaminated radiator	Clean the exterior of the radiator
	Defective V-belt offset	Adjust or replace it
	Contaminated or damaged V-belt	Replace it
	Damaged impeller	Replace the water pump
	Defective impeller fix	Replace the water pump
	Bad water pump operation	Replace it
	Bad thermostat operation	Replace it
	Bad coolant flow	Clean the coolant path
	Improper injection time	Check it with the failure diagnosis unit
Damaged cylinder head gasket	Replace it	
Overcooled engine	Bad thermostat operation	Replace it
	Too low ambient temperature	Heat the block
Leaking coolant	Damaged radiator	Repair or replace it
	Loosened or damaged radiator connection	Repair or replace the connection
	Defective radiator cap	Replace it
	Badly mounted water pump	Repair or replace it
	Bad or damaged water pump gasket	Replace the gasket
	Badly mounted thermostat	Repair or replace it
	Bad or damaged thermostat gasket	Replace the gasket
	Damaged cylinder head gasket	Replace the gasket
	Damaged cylinder head or block	Replace it
Noise	Bad water pump bearing	Replace the bearing
	Bad or damaged cooling fan	Repair or replace it
	Bad rotation of the cooling fan	Replace it
	Defective V-belt offset	Adjust or replace it

### Thermostat

#### General information

The thermostat maintains water temperature in the engine consistently and prevents heat loss to improve heat efficiency of the engine.

When the coolant temperature is below the normal temperature, the thermostat is closed and the coolant is bypassed and directly flows into the water pump. When the coolant temperature reaches the normal temperature or is higher than the temperature, the thermostat is fully open and the bypass circuit is closed. So the coolant flows into the radiator.

#### **⚠ CAUTION**

- **The wax pellet type thermostat shows slower response to the change of cooling water than the bellows type thermostat. This happens because the heat capacity of the wax pellet type thermostat is larger than that of the bellows type thermostat. Therefore, to prevent a rapid increase in the engine coolant's temperature, you must first operate the engine at idle until the engine is fully warmed up. When the weather is very cold, do not operate the engine in an overloaded condition or at a high speed after starting the engine.**
- **When draining water from the engine cooler or injecting water to the engine cooler, work slowly to ensure that all air inside the cooler is expelled.**
- **When a defect is found in the thermostat, replace it with a new one.**

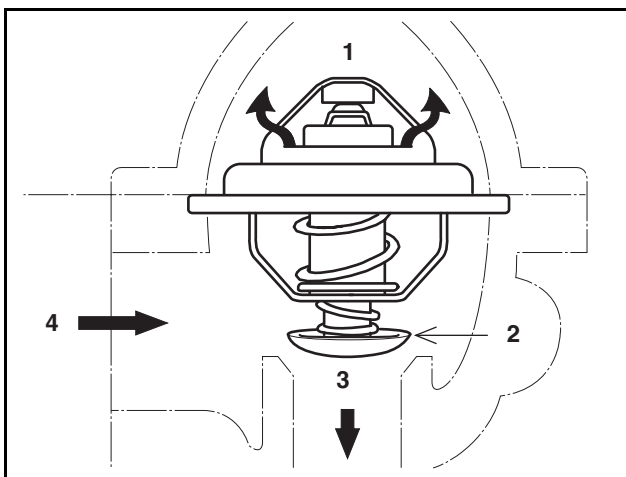

EDL022060A

- |                   |                 |
|-------------------|-----------------|
| 1. Heat Exchanger | 3. water pump   |
| 2. Bypass valve   | 4. Coolant pipe |

#### Cautions for replacement and handling of thermostat

1. Cautions for handling  
A wax pellet type thermostat features relatively slow response for change in coolant temperature compared to a bellows type. This is because the wax pellet type has larger thermal capacity. Therefore, it needs to idle the engine sufficiently before running it in order to prevent surge of engine coolant temperature. In cold weather, never overload the engine or speed drive.
2. When adding or draining coolant to/from the engine cooling system, do it slowly to let air in the system escape.
3. Thermostat replacement  
If any defect is found on the thermostat, replace it with a new one.

#### Thermostat inspection

1. Check if the wax pellet and spring are damaged.
2. Put the thermostat into water and heat the water gradually to check for operation of the thermostat.  
If the thermostat starts to open at 83 °C (water temperature) and it is fully open at 95 °C, it is normal.

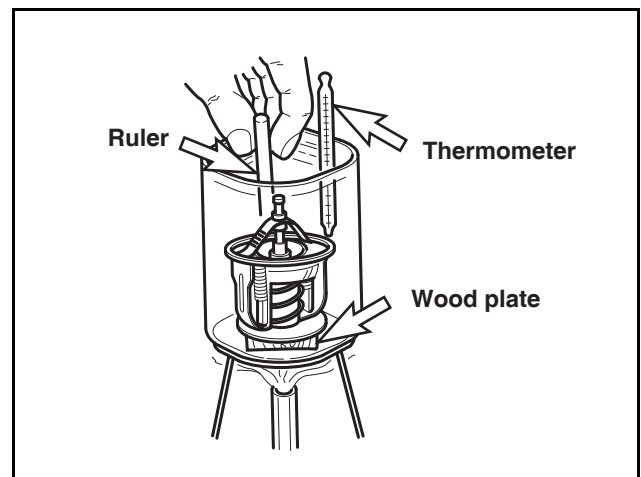

EFM2055IE

3. Check if there is any foreign material in the thermostat. Note) Clean the inside of the thermostat using a air gun.
4. Check the hose for internal or external damage or foreign materials.

## 6. Cooling system

---

### Cooling fan

#### General information

##### 1. Overview and specifications

The speed of the cooling fan is controlled by the electronic fan clutch in order to maintain its optimum speed. The electronic fan clutch adjusts the cooling fan speed electrically according to the coolant temperature, hydraulic oil temperature, CAC (Cooled Charge Air) temperature and engine speed to reduce cooling fan noise and obtain superior efficiency.

##### 2. Inspection

If the connecting cable is damaged, the cooling fan is operated at the full speed to protect the cooling system.

##### 3. Cooling fan removal and installation

Be careful of the followings when removing and installing the cooling fan:

- 1) The cooling fan weighs approx. 9.0 kg. When removing or installing the cooling fan, be careful not to damage the fan and radiator.
- 2) If the electronic clutch cable is not firmly fixed, it can be damaged by the rotating cooling fan. After installing the cooling fan, confirm that the connecting cable is correctly secured.
- 3) Make sure to tighten the cooling fan to the specified torque.

Tightening torque for M8 bolt	2.2 kg·m
Tightening torque for M10 bolt	4.4 kg·m

##### 4. Cautions for handling

If the cable is not correctly connected, the cooling fan operates at its full speed at all times. Check the rotating speed of the cooling fan after its installation.

# 7. Lubrication system

General information .....	137
General information .....	137
Failure diagnosis.....	138
Oil pump .....	139
General information .....	139
Oil pump disassembly and assembly.....	139
Oil pump inspection .....	139





## 7. Lubrication system

### General information

#### General information

This engine is a forced lubrication type. Oil pressure is generated and supplied by rotation of the oil pump gear which is engaged with the crankshaft gear on the back of the cylinder block.

The oil pump receives oil from the oil pan through the suction pipe to send it to the main passage of the cylinder block through the oil filter and oil cooler. Then, it is distributed to the crankshaft bearing, camshaft bearing and rocker arm for lubrication.

Also, as the turbocharger is connected to the engine lubrication circuit, it receives oil for engine brake operation.

Lubricant is sprayed around the cylinder block and timing gear. Each cylinder is equipped with its own oil spray nozzle to cool down the internal section of the piston. Engine oil is filtered by the oil filter.

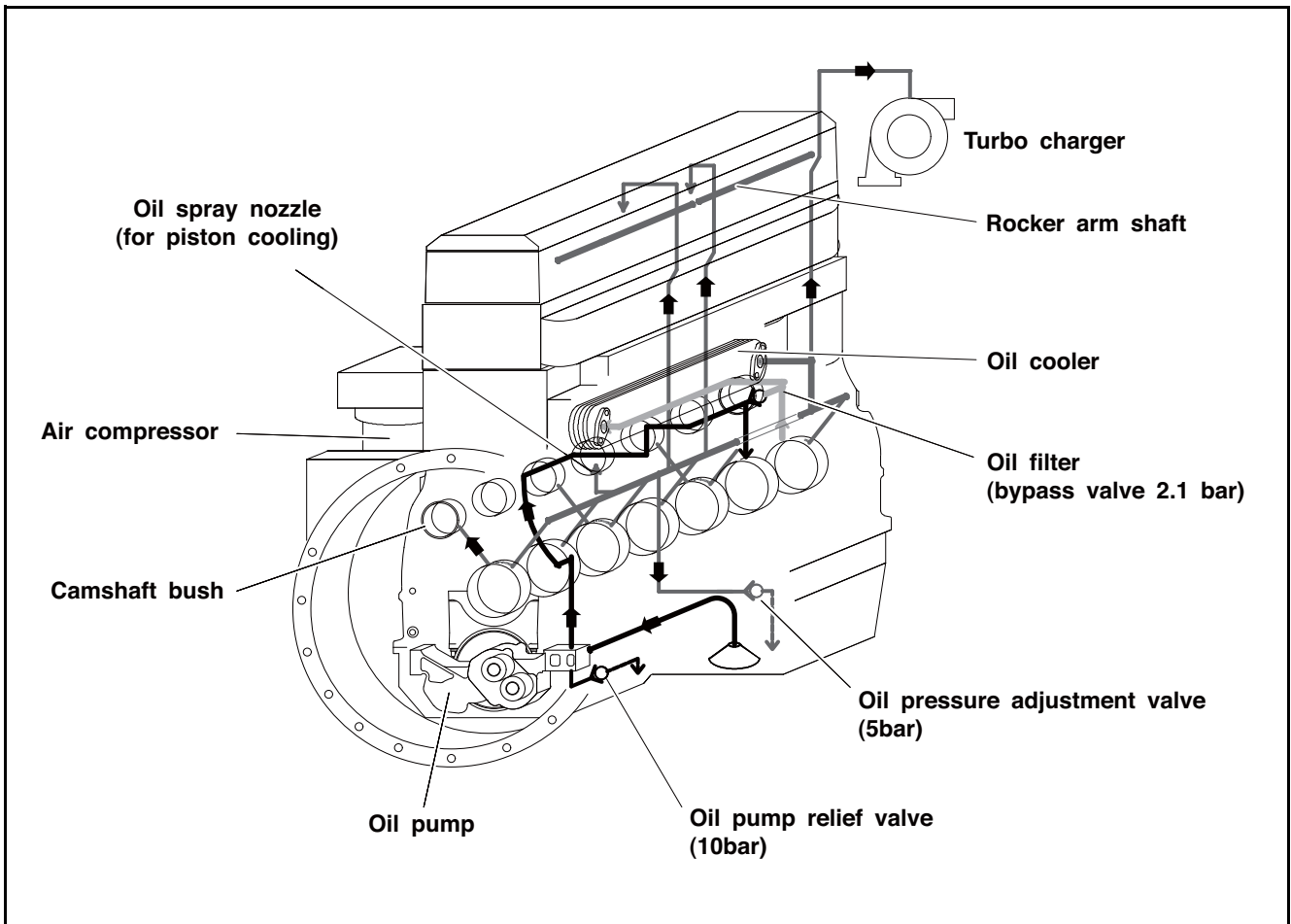

EK1OM015-E

## 7. Lubrication system

### Failure diagnosis

Phenomenon	Causes	Troubleshooting
Too much oil consumption	Bad oil	Replace oil with specified oil.
	Oil leakage from the oil seal ring and packing part	Replace it
	Worn or damaged piston and piston ring	Replace it
	Worn cylinder liner	Replace it
	Burnt piston ring	Replace it
	Worn valve guide oil seal, valve guide, or valve stem	Replace it
Low oil pressure	Bad oil	Replace oil with specified oil.
	Burnt oil pump relief valve	Replace it
	Clogged oil pump strainer	Cleanse the strainer
	Worn oil pump gear	Replace it
	Cracked oil delivery pipe of the oil pump	Replace it
	Defect oil pump	Repair or replace it
	Oil pressure gauge fault	Repair or replace it
	Worn bearings	Replace it
Contaminated oil	Clogged oil filter	Replace the oil filter with a new one
	Gas leakage	Replace piston ring with a new one
	Bad oil	Replace oil with specified oil.

## Oil pump

### General information

Engine oil is sucked from the oil pan by the gear type oil pump and then all of the oil is forcibly delivered to the oil cooler and filter for filtering. The filtered oil passes through the main oil path of the cylinder block and lubricates bearing parts and the turbocharger of the engine in order to maintain normal engine performance.

### Oil pump disassembly and assembly

#### [Disassembly]

1. Remove the oil pump drive gear.
  - 1) Loosen the screw to remove the oil relief valve.
  - 2) Unfold the lock washer of the oil pump drive gear to remove the mounting nut and washer.
  - 3) Remove the drive gear.
2. Unscrew the mounting nut of the oil pump cover to remove the oil pump cover.

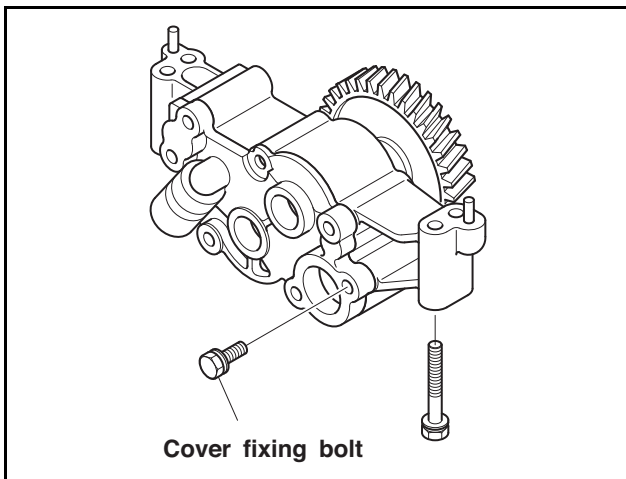

EE10M142-E

Note) The oil pump cover is fixed

3. to the body with 2 retaining pins.
4. Remove the drive gear and driven gear.

#### [Assembly]

1. Assemble in the reverse order of disassembly.

### Oil pump inspection

1. Use a steel ruler and feeler gauge to measure the axial play of the oil pump gear. If the measurement is over the allowable limit, replace it.

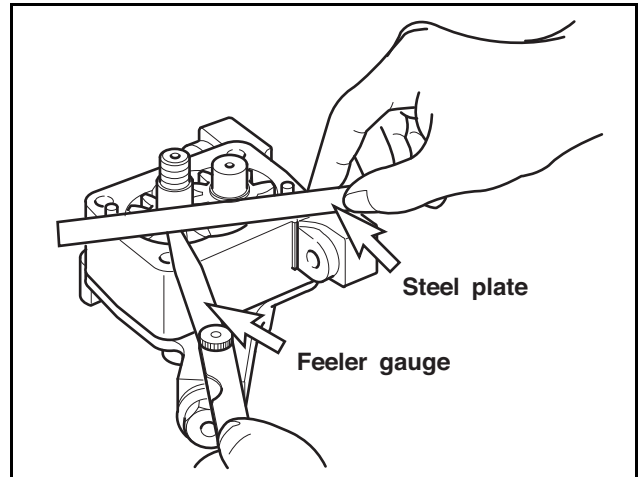

EQM4008I-E

Allowable limit	0.03 - 0.136 mm
-----------------	-----------------

2. Use a feeler gauge to measure the backlash between the drive gear and driven gear of the oil pump. If the measurement is over the allowable limit, replace it.

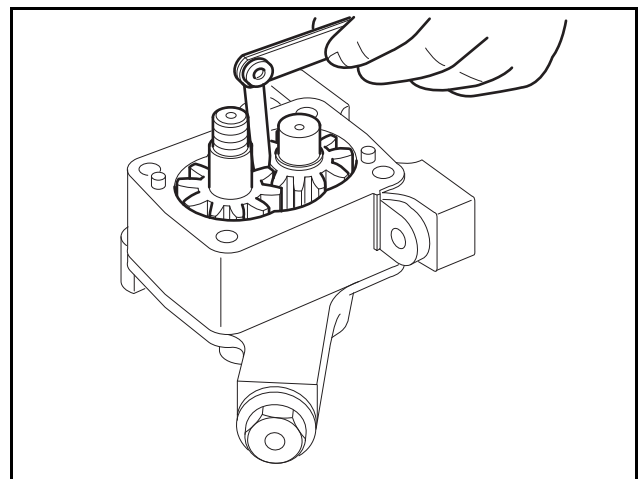

EQM4009I

Standard	0.312 - 0.476 mm
Allowable limit	0.64 mm

3. Measurement of clearance between drive shaft and bushing
  - 1) Measure the outside diameter of the drive shaft and drive shaft. If any measurement is below the allowable limit, replace the corresponding part.

## 7. Lubrication system

---

Standard	Ø21.936 - Ø21.95 mm
Allowable limit	Ø21.90 mm

- 2) Measure the inside diameter of the pump body bushing and the outside diameter of the shaft. Compare this measurement with the standard oil clearance value to determine the necessity of replacement.

Oil clearance	0.05 - 0.085 mm
---------------	-----------------

# 8. Fuel system

General information .....	143
General information .....	143
Fuel high-pressure system components .....	144
Injector .....	145
General information .....	145
How to operate an injector .....	145
Injector protrusion .....	146
Common rail .....	147
General information .....	147
Fuel injection pump .....	149
General information .....	149
Fuel feed pump .....	151
General information .....	151



### General information

#### General information

This diesel engine compresses air delivered into its cylinders and sprays fuel with its injection nozzles to burn fuel with compression heat.

When the high-pressure pump produces high-pressure fuel, this fuel is kept by the common rail and its injection timing and injection amount are calculated by the ECU (Electronic Control Unit). The ECU (Electronic Control Unit) operates the solenoid valves of the injectors on each cylinder to inject fuel. This common rail fuel injection system has the high-pressure producing part and the fuel injection part separated. The ECU determines the fuel injection amount, injection timing and injection pressure according to the operating condition of the engine before injecting fuel into the cylinders in order to ensure optimum engine performance.

As the high-pressure pump produces high-pressure fuel, this fuel is kept by the common rail. When a driver operates the vehicle, the optimum fuel injection timing and injection amount are determined by the ECU (Electronic Control Unit) based on the preset data, vehicle speed and driving condition. Then the ECU operates the solenoid valves of the injectors on each cylinder to inject a proper amount of fuel into the cylinders.

The fuel tank should be made of non-corrosive material, and the fuel low-pressure pump should not leak at twice the operating pressure. Also, the pressure in the tank should not exceed 0.3 bars.

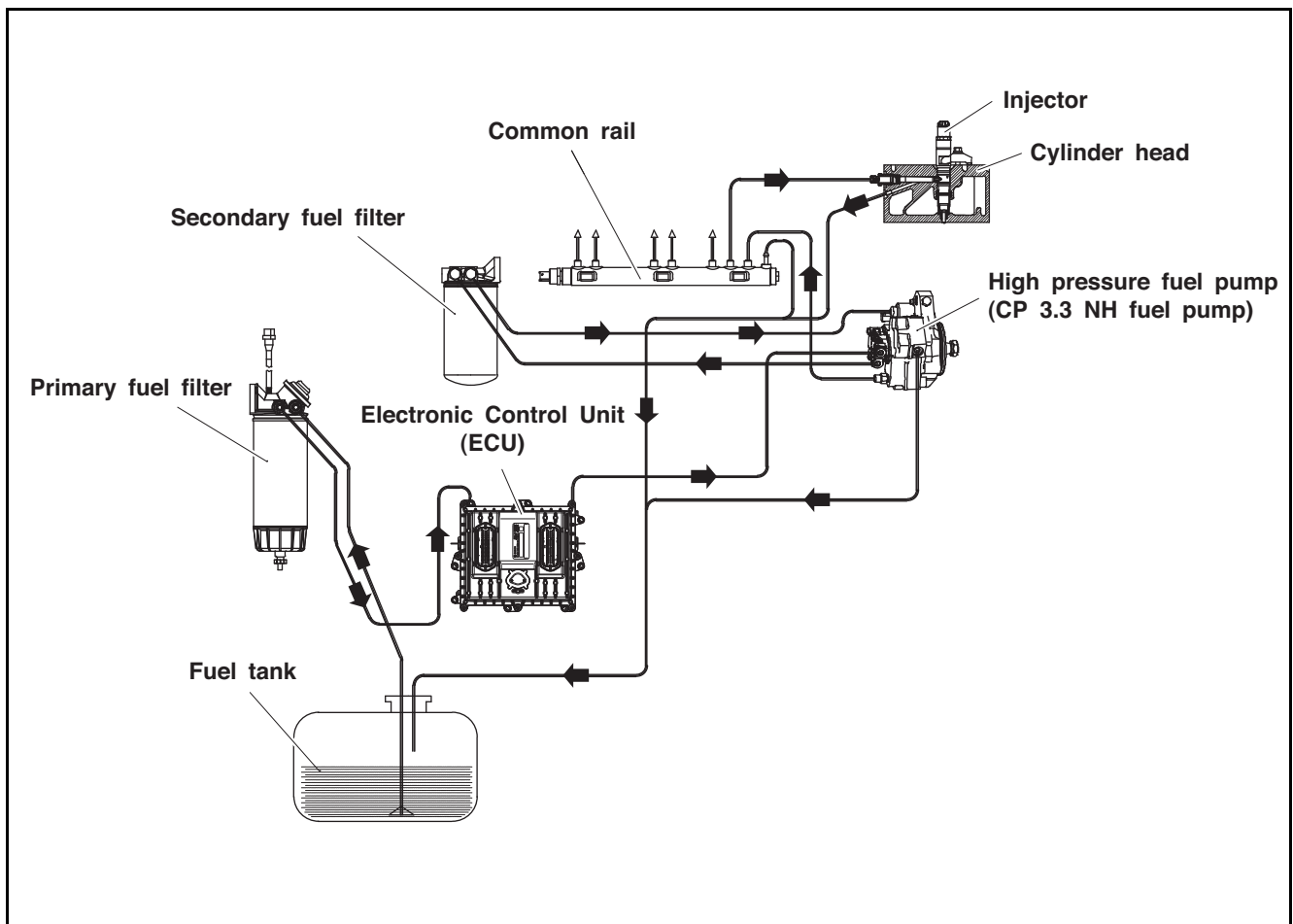

EK10M013-E

## 8. Fuel system

---

### Fuel high-pressure system components

The common rail fuel injection system consist of the low-pressure stage for low-pressure fuel delivery, high-pressure stage for high-pressure fuel delivery, and electronic control unit.

1. Fuel high-pressure pump

The fuel high-pressure pump pressurizes fuel up to approx. 1,800 bars and sends this pressurized fuel to the common rail (pipe shape) through the high-pressure line.

2. Common rail

Even after the injector uses fuel from the common rail to inject fuel, the fuel pressure in the common rail is still maintained at a constant level. The common rail pressure sensor detects the fuel pressure while the pressure control valve maintains the fuel pressure at the desired level. The fuel pressure in the common rail is controlled to max. 1,800 bars by the pressure control valve.

3. Injector

As the solenoid valve is operated, fuel flows to the injector nozzle which then sprays fuel directly into the combustion chamber.

When the injector nozzle opens and sprays the commanded amount of fuel, the excess fuel is returned to the tank through the return line. Also, fuel returned from the fuel pressure control valve and low-pressure stage and fuel used to lubricate the high-pressure pump are returned back to the fuel tank through the return line as well.

4. Fuel high-pressure pipe

The fuel high-pressure pipe carries high-pressure fuel at 1,800 bars. Therefore, this pipe is made of special material to be able to withstand the maximum pressure of the system and fluctuation of high pressure occurred during fuel injection. The high-pressure pipe has 8.0 mm of outside diameter and 3.5 mm of inside diameter. Also, the fuel high-pressure pipes installed between the common rail and injectors should be in the same length and they are installed as short as possible.



### Injector

#### General information

The injector uses the nozzle to inject fuel to the combustion chamber directly. To control the injection, the solenoid valve is used. Fuel is delivered as much as required from the open injector nozzle and the remaining fuel is returned to the fuel tank through the fuel return line. In addition, the fuel which has been used to lubricate the high-pressure pump and returned from the fuel pressure adjustment valve is returned to the fuel tank through the return line.

The solenoid valve controls the fuel injection timing and amount. The injector works instead of the nozzle and the nozzle holder mounted on the existing engine. Fuel is delivered to the injector through the high-pressure connector mounted on the cylinder head and then delivered to the valve control chamber through the delivery hole.

The valve control chamber is opened by the solenoid valve. It is connected to the fuel return line via the discharge hole. The hydraulic force which has been increased by the valve control plunger with closed discharge hole exceeds the pressure value of the nozzle needle. As a result, fuel delivery to the combustion chamber is blocked by the force given to the contact surface of the nozzle needle.

When the solenoid valve of the injector is pulled, the discharge hole is opened. This lowers the pressure in the control chamber and the hydraulic power given to the plunger. When hydraulic force is lower than the force given to the nozzle needle pressure, the nozzle needle is opened. Finally, fuel is injected to the combustion chamber through the injection nozzle hole.

The reason that the nozzle needle is controlled by hydraulic force is that the power required to open the needle quickly cannot be directly generated from the solenoid valve. Fuel control amount required to open the nozzle needle is added to the fuel amount injected. The used fuel is discharged to the fuel return line through the hole of the valve control chamber.

Fuel loss occurs on the nozzle needle, the valve plunger guide as well as the valve control chamber. The control leakage fuel and the fuel gathered from the line, which connects the over flow valve, the high-pressure pump, and the pressure control valve, is returned to the fuel tank through the fuel return line.

#### How to operate an injector

Injector operation is classified into four operation stages to operate the engine and create pressure in the high-pressure pump.

1. The injector is closed (high fuel pressure state)
2. The injector is open (starting fuel injection).
3. The injector is fully open (injecting fuel).
4. The injector is closed (ending fuel injection). These operation stages are decided by balancing the force given to the injector components. If there is no pressure on the common rail or the engine is stopped, the injector nozzle does not work.

1. The injector is closed (pause state)

Under the pause state that no power is provided to the solenoid valve of the injector, the injector does not operate. The surface where the discharge hole exists is tightly closed with the valve ball by the force from a valve spring or magnet. High pressure in the common rail is kept by the fuel control valve and the same pressure is generated in the nozzle chamber of the injector. The common rail fuel pressure, which is given to the end face of the valve control chamber of the injector, and the injector nozzle spring force are larger than the force to open the nozzle. Therefore, the injector is closed.

2. The injector is open. (starting fuel injection)

When power is supplied while the injector solenoid valve is closed, the fuel discharge hole is open by the pulling force of the solenoid valve. Almost simultaneous with that, the high current given to the solenoid valve is reduced to the low current. This is because the air gap of the electromagnet circuit gets smaller. Fuel in the valve control chamber flows to the discharge valve hole on the upper side and then goes into the fuel tank via the fuel return line. The discharge hole completely breaks the pressure balance and lowers the pressure in the valve control chamber. As a result, the pressure in the valve control chamber is lower than the nozzle chamber pressure which has been equal to the common rail pressure. The lowered pressure of the valve control chamber lowers the force from the control plunger. So the nozzle needle is open and fuel injection starts.

3. The injector is fully open. (injecting fuel)

The valve control plunger is stopped at the upper position because fuel is full as fuel flows from the fuel delivery hole. At this time, the injector nozzle is fully open and fuel is injected to the combustion chamber at the pressure equal to that of the common rail.

## 8. Fuel system

### 4. The injector is closed. (ending fuel injection)

As soon as the supply to the solenoid valve of the injector is blocked, the valve spring applies force to the armature downward and the valve ball closes the discharge hole. The armature consists of two components. The armature plate is guided by the driving shoulder and pressed downward. However, in this case, an overspring is used. It is a return spring that prevents the force from being applied to the armature and the valve ball. As the discharge hole is closed, fuel is delivered from the delivery hole and generates pressure in the control chamber. This fuel pressure is equal to the pressure of the common rail and puts pressure on the valve control plunger through the end face of the valve control plunger. As a result, the force of the spring is added to the pressure exceeding the pressure of the nozzle chamber. Therefore, the nozzle needle is closed. The speed of closing the nozzle needle is decided by the flow that passes through the delivery hole. As soon as the nozzle needle is positioned to the stop position, fuel injection is blocked.

### Injector protrusion

1. Insert the seal ring to the cylinder head, and install the injector.

Note) Refer to the engine assembly instruction for installation steps.

2. Measure the protrusion of the injector from the cylinder head, and adjust it as necessary.

A (seal ring thickness)	2.0 mm
B (injector protrusion)	3.0 mm

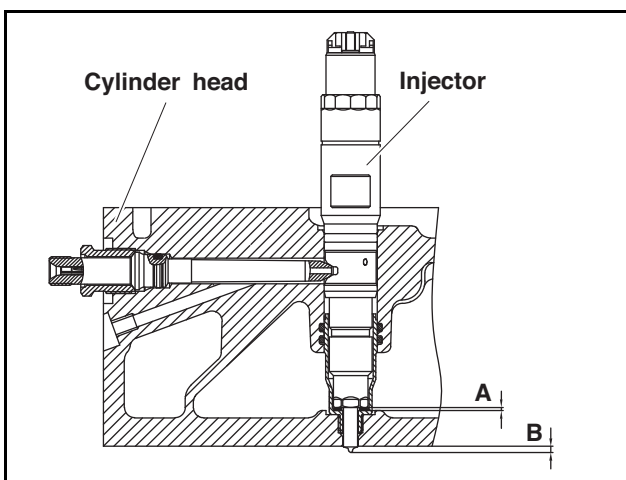

EE10M075-E

### Common rail

#### General information

This common rail fuel injection system has the high-pressure producing part and the fuel injection part separated.

The ECU determines the fuel injection amount, injection timing and injection pressure according to the operating condition of the engine before injecting fuel into the cylinders in order to ensure optimum engine performance.

The common rail stores fuel under high pressure delivered from the high-pressure fuel pump.

Even after the injector uses fuel from the common rail to inject fuel, the pressure pulse in the common rail is still maintained by the volume of the rail to keep the fuel pressure at a constant level.

The common rail pressure sensor detects the fuel pressure while the pressure control valve maintains the fuel pressure at the desired level. The fuel pressure in the common rail is controlled to max. 1,800 bars by the pressure control valve.

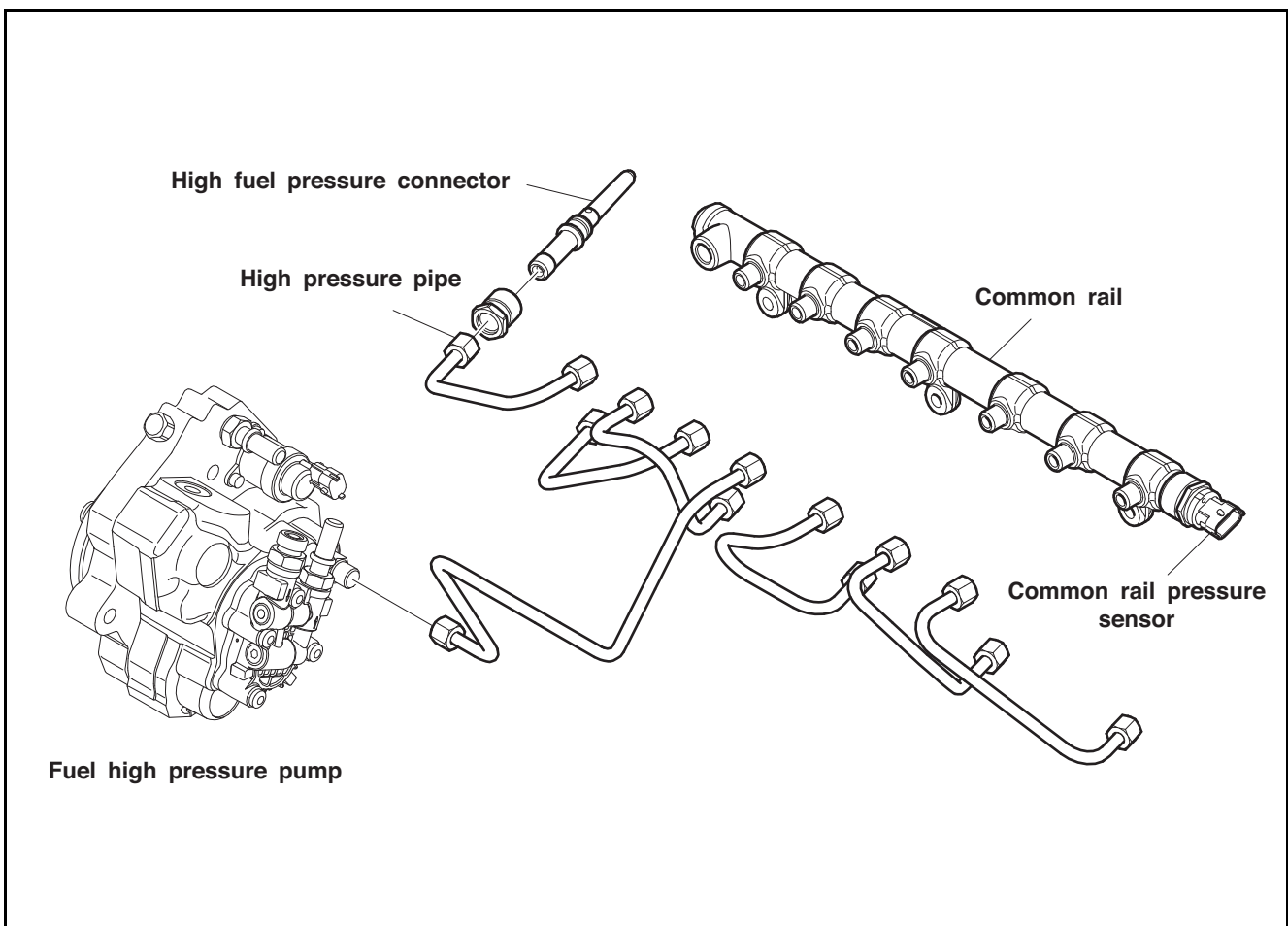

EK40M007-E

The common rail fuel injection system consists of the following main components:

1. ECU (Electronic Control Unit)
2. Crankshaft speed sensor
3. Camshaft speed sensor
4. Accelerator pedal sensor
5. Fuel temperature sensor
6. Boost pressure and temperature sensor, oil pressure and temperature sensor
7. Common rail pressure sensor
8. Coolant temperature sensor

- As a driver depresses the accelerator pedal, the ECU (Electronic Control Unit) receives information from various sensors mentioned above to operate the engine and vehicle according to the operating condition instantly. Also, the ECU operates the open/closed circuits and circulation circuit of the vehicle and engine based on such information.

## 8. Fuel system

- The crankshaft speed sensor detects the engine speed while information from the camshaft speed sensor is used to determine the ignition order. The potentiometer of the accelerator pedal sensor produces an electric signal to inform the ECU of how deep the pedal is depressed. Also, the turbocharger and intake pressure sensor are installed, and the intake pressure sensor is used to measure the intake air pressure.
- When the engine temperature is low in cold weather, the ECU receives information from the coolant temperature sensor and air temperature sensor to operate the engine ideally based on the current operating condition.

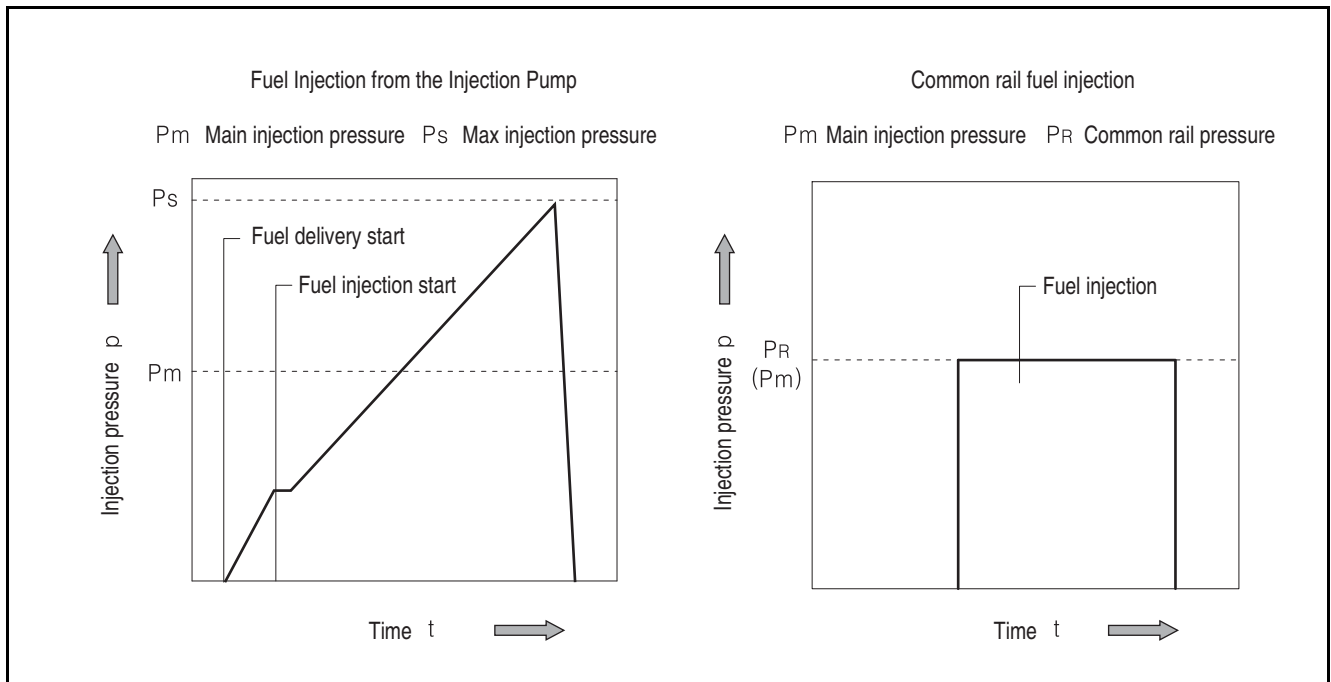

EDL0213004A

The common rail features the injection characteristics as follows:

1. Compared to the conventional system's injection characteristics, the common rail manages the fuel injection amount and injection pressure separately to satisfy with any engine condition in order to ensure optimum fuel injection.
2. In the initial fuel injection period, i.e. the ignition delay from the beginning of fuel injection until the beginning of combustion, the fuel injection amount should be adjusted to a low level.
3. The common rail system is a modular type and has the following major components for its injection characteristics:
  - 1) Injector solenoid valve (installed to cylinder head)
  - 2) Common rail
  - 3) Fuel high-pressure pump
  - 4) ECU (Electronic Control Unit)
  - 5) Crankshaft speed sensor

### Fuel injection pump

#### General information

The fuel high-pressure pump uses a radial shaped piston pump to produce high pressure. Pressure is independently generated during the fuel injection process. The speed of the fuel high-pressure pump is directly connected to the engine RPM, regardless of the transmission's speed ratio. Compared to the conventional injection system, the common rail injection system delivers a certain amount of fuel constantly.

The injector is connected to the common rail with the high-pressure pipe. It consists of the nozzle and solenoid valve which is energized by the ECU when the ignition switch is operated. When the ignition switch is blocked, the solenoid valve ends the injection operation.

As the switching (opening/closing) operation of the injector's solenoid valve is performed by high voltage and current, the injectors' solenoid valves are operated in sequence according to the preset value in the ECU. The crankshaft speed sensor and camshaft speed sensor are used to detect the engine speed in order to adjust the fuel injection timing and the beginning of fuel injection correctly.

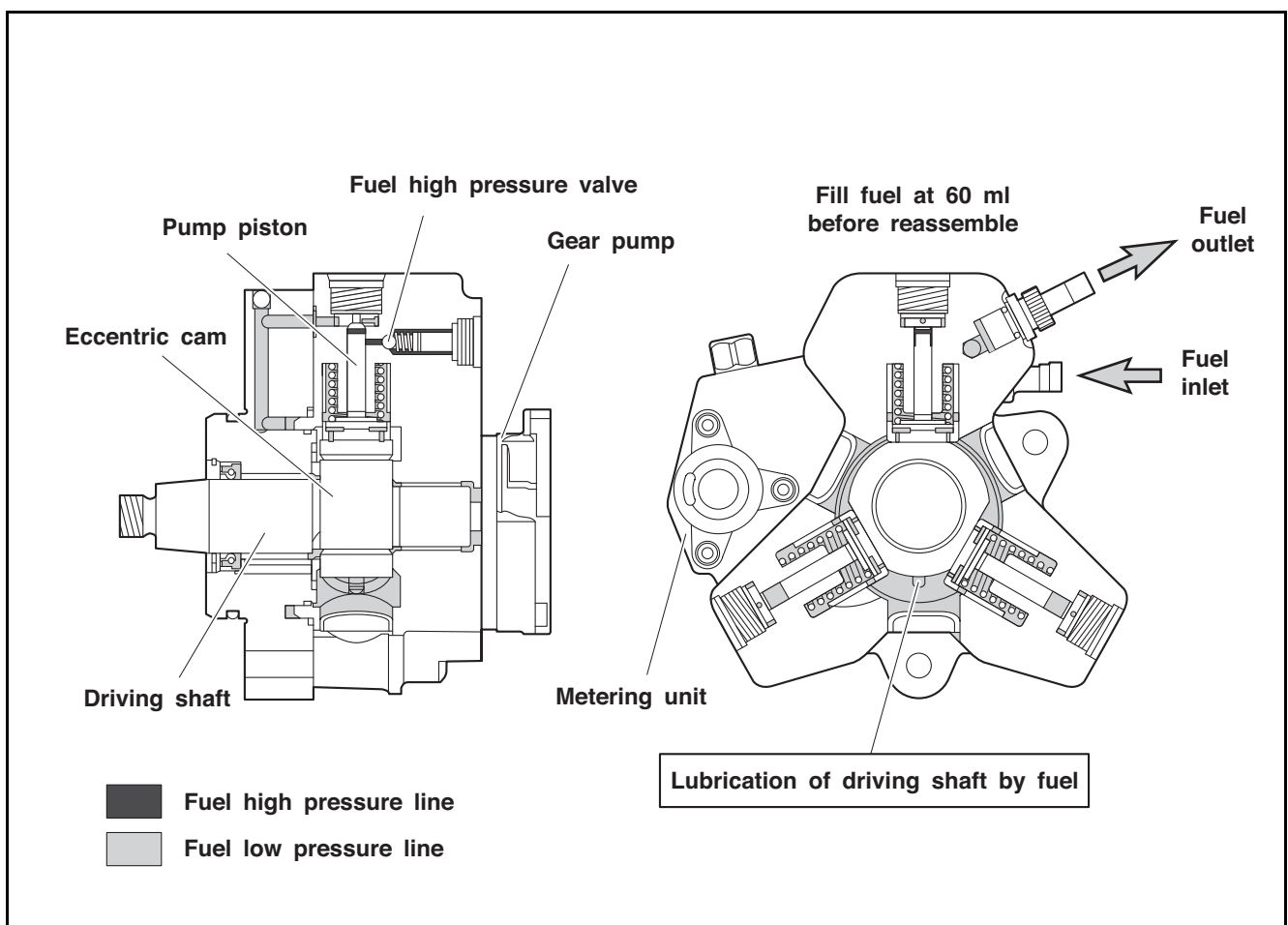

EE1OM096-E

#### 1. Function

1) The fuel high-pressure pump has both low pressure stage and high pressure stage. It carries high pressure fuel under any operating circumstance during the service life of the vehicle. Also, it supplies a proper amount of fuel to the common rail to handle any harsh condition, such as abrupt vehicle start or rapid change of pressure in the common rail. The fuel high-pressure pump produces the system pressure required in the common rail constantly.

#### 2. Structure fuel high-pressure pump

1) The fuel high-pressure pump has three pump pistons set 120° apart from each other in it to compress fuel in the circumferential direction. As every rotation creates three compression strokes, the pump drive system's stress is maintained steadily and it needs low driving force. The common rail needs low pump driving force which is only approx. 1/9 of force required for the conventional pump system.

## 8. Fuel system

### 3. Operation

- 1) The fuel feed pump supplies fuel to the high-pressure pump through the fuel inlet and safety valve. Then, this fuel is transferred to the high-pressure pump's lubrication and cooling circuits through the safety valve. The drive shaft is equipped with the eccentric cam to move the pump's piston up and down according to the shape of the cam.
- 2) If the fuel pressure delivered from the fuel feed pump exceeds the fully open pressure of the safety valve, fuel moves the pump piston downwards through the intake valve of the fuel high-pressure valve to the intake stroke position of the pumping chamber. When the pump piston passes the B.D.C., the valve is closed. Then, as fuel cannot escape the pumping chamber, it is compressed further over the delivered pressure.
- 3) As soon as the fuel pressure reaches the common rail pressure, it opens the exhaust valve. Then, this compressed fuel enters the high-pressure circuit. The pump piston continues to carry fuel until it reaches the T.D.C. Then, as soon as the pressure drops, the exhaust valve is closed. Then, fuel left in the pumping chamber is depressurized and the pump piston moves downwards again. When the pressure in the pumping chamber drops below the pressure of the fuel feed pump, the intake valve opens and the above steps are repeated.

### 4. Fuel return

- 1) The fuel high-pressure pump is designed to supply a large amount of fuel. While the engine is running at an idle speed or with partial load, excess fuel is returned to the tank through the pressure control valve.

### 5. Fuel high-pressure pumping cut-off valve

- 1) When the switch of the fuel high-pressure pumping cut-off valve is turned off, the fuel amount delivered to the common rail is increased. When the switch is turned off, the fuel pumping solenoid valve is pulled, so the pin attached to an electric magnet keeps the valve open. Therefore, fuel led into the pumping valve cannot be compressed during the delivery stroke. As this fuel is returned to the low-pressure passage, no pressure is produced. Since the pumping cut-off valve is operated only with a small amount of force, it is possible to switch between the delivery phase and cut-off phase at short intervals.

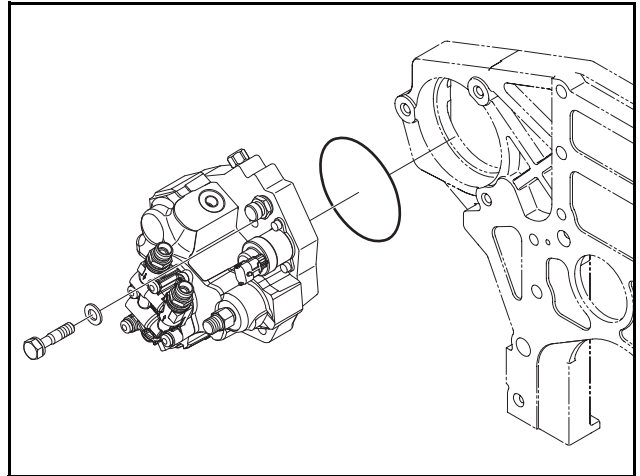

EK4OM100

### Fuel feed pump

#### General information

The fuel feed pump is located behind the fuel high-pressure pump and it is a gear driven type. The fuel feed pump draws fuel from the fuel tank to supply the required amount of fuel continuously toward the high-pressure pump.

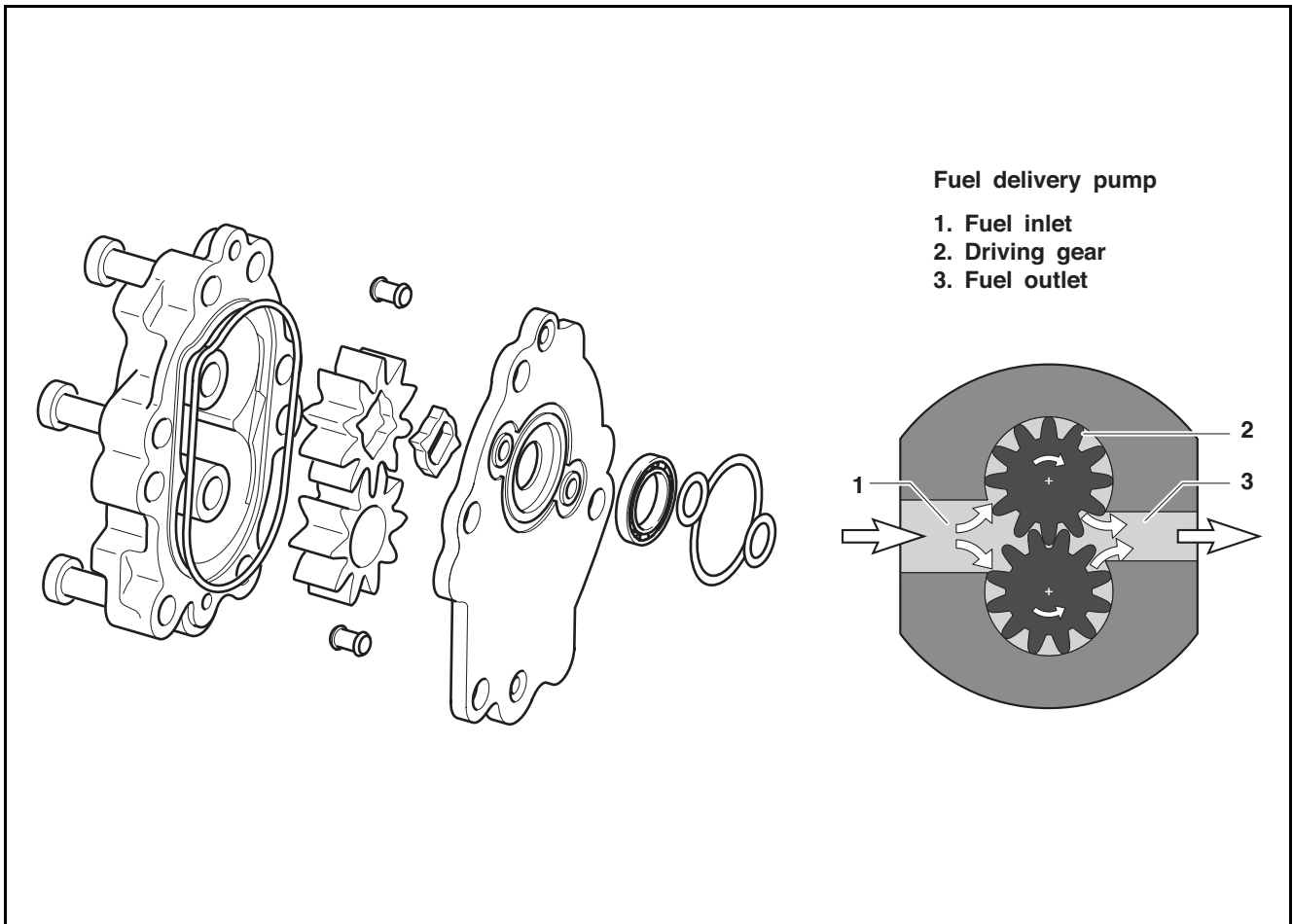

EE1OM095-E

## 8. Fuel system

---



# 9. Intake/Exhaust system

General information .....	155
General information .....	155
Turbocharger .....	156
General information .....	156
Structure .....	158
Failure diagnosis.....	159
How to maintain turbocharger.....	163
Inspection items during disassembly/assembly of turbocharger.....	165
Turbocharger inspection .....	166
EGR (Exhaust Gas Reduction) system .....	168
General information .....	168
EGR disassembly and assembly .....	170
EGR cooler disassembly and assembly .....	170
Intake pipe .....	171
Major air heater specifications .....	171



### General information

#### General information

This engine is a state-of-the-art engine made of advanced technologies available to comply with strict emission control, enhance fuel consumption and reduce emissions.

## 9. Intake/Exhaust system

### Turbocharger

#### General information

The turbocharger uses heat energy of exhaust gas in the engine to draw in high density air into the cylinders to increase the engine power.

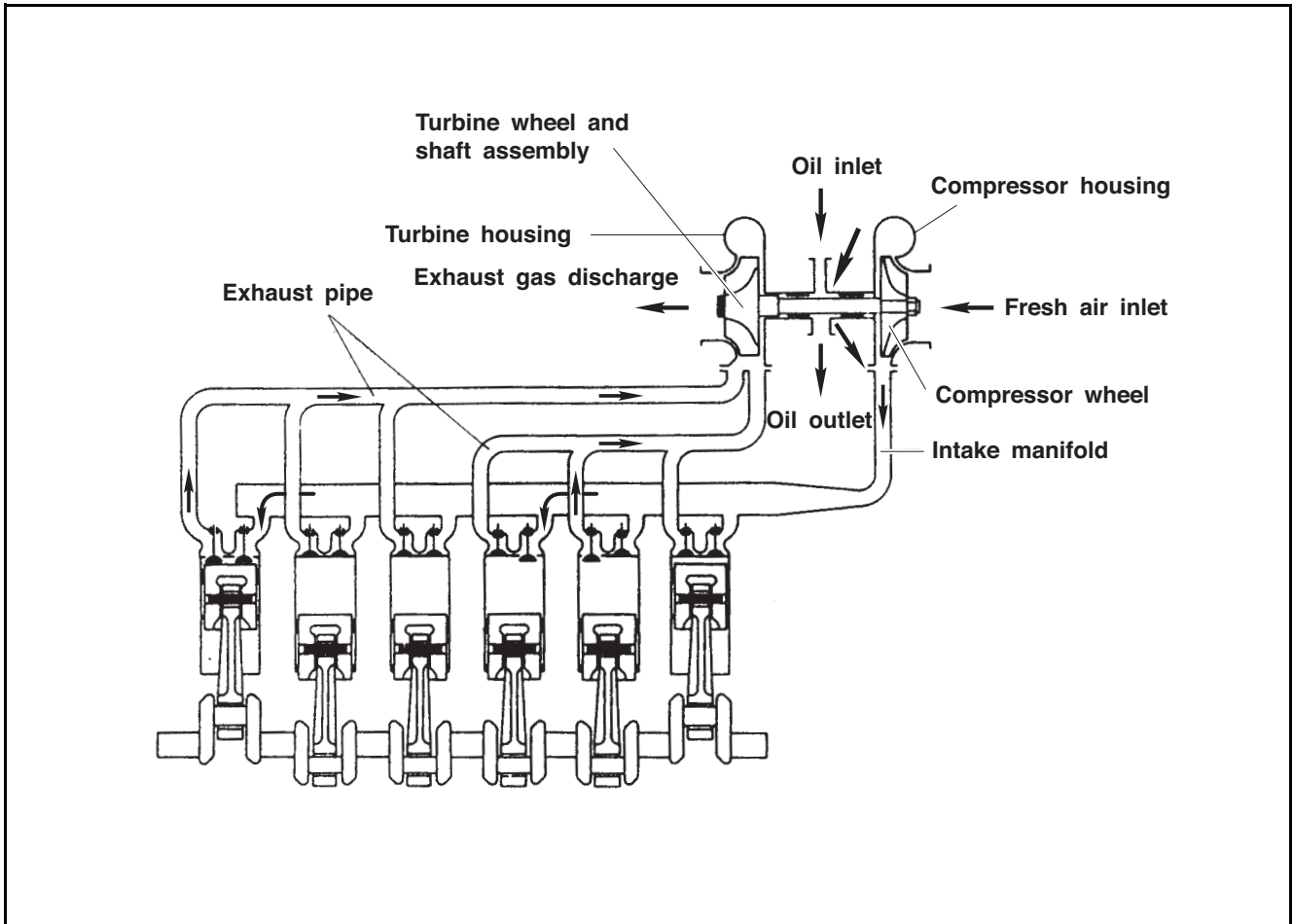

EA0M8001-E

1. Power of the engine is determined by the amount of fuel supply and the engine's efficiency.
2. A sufficient amount of air should be supplied to the cylinders to burn fuel completely and convert this energy to effective work.
3. Power of the engine is actually determined by the size of the cylinders. The larger the cylinders are, the more the air is delivered to burn more fuel, resulting in increase of engine power.
4. Turbocharging is a process to compress and supply air into the engine's cylinders. The turbocharger is a device to supply extra air for combustion with energy of exhaust gas in the combustion chamber which is usually released and disappeared into the air.
5. The turbocharger has the following major functions:
  - 1) Turbine: As exhaust gas discharged from the combustion chamber passes through the turbine housing, its energy is transferred to the turbine blades to deliver the rotating force to the turbine shaft. These series of motions are occurred in a component called turbine. The turbine is equipped with the seal ring and heat shield to prevent exhaust gas from affecting its bearing.
  - 2) Compressor: As it is connected to the same shaft with the turbine, it rotates together to receive rotating force from the turbine shaft in order to receive, compress and send air to the intake manifold. This is the basic principle of a compressor.
  - 3) Bearings:
    - Thrust bearing: The turbine wheel is applied with axial force. This axial force keeps the shaft from moving.

- Journal bearing: This bearing is a floating type and has double oil film on its inside and outside so that it can rotate independently. As its double oil film acts as a cushion, the sliding speed on the bearing surface becomes lower than the rotating speed of the shaft, ensuring dynamic stability.
- 4) Seal ring of compressor shaft: The shaft is equipped with the seal plate and seal ring in a dual structure to prevent leakage of compressed intake air and lubricant.

## 9. Intake/Exhaust system

### Structure

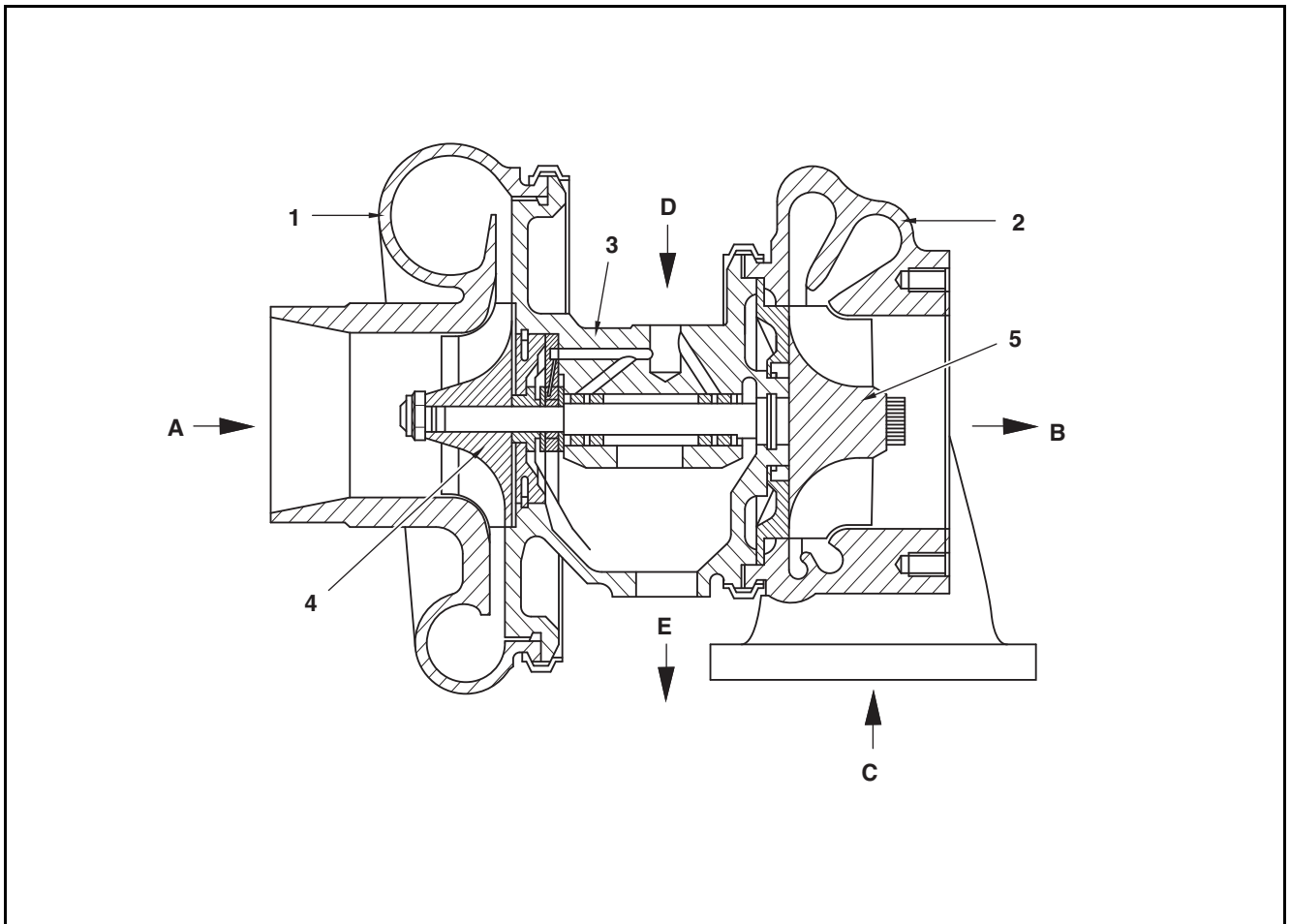

EAO5008I

1. Impeller casing
2. Turbine casing
3. Bearing casing
4. Impeller
5. Turbine

- A. Intake air inlet
- B. Gas outlet
- C. Gas inlet
- D. Oil supply
- E. Oil discharge

## 9. Intake/Exhaust system

### Failure diagnosis

Phenomenon	Causes	Troubleshooting
Noise or vibration	Rotating part is contacted	Repair or replace it
	Unbalanced rotation of a rotor	Repair or replace it
	Burn	Repair or replace it
	Loose joint	Check or repair it
	Deformed or damaged intake unit hose	Replace it
	Poor clamping state	Adjust and tighten the clamp
	Contaminated or damaged air filter	Replace and check if the impeller of the turbocharger is damaged
	Leakage of coolant from the turbocharger or oil from the oil hose	Replace the hose and the gasket
	Leakage of gas from the exhaust manifold	Replace the gasket or tighten the fixing nut
	Poor turbo actuator operation	Replace the turbocharger
	Leakage from the engine block and the exhaust manifold	Check the engine
	Contaminated blowby gas and abnormal oil amount	Check the turbo impeller and the turbo intake outlet
	Large gap of the turbocharger wheel, causing interference with the wall	Check if there is any sand or metallic foreign substance
	Damaged turbocharger wheel	Check if there is any sand or metallic foreign substance
	Damaged wheel and shaft of the turbocharger	Check if there is any sand or metallic foreign substance
Poor rotating force of the turbocharger wheel	Check if there is any sand or metallic foreign substance	

## 9. Intake/Exhaust system

Phenomenon	Causes	Troubleshooting
Lowered output	Leakage of gas from each part of the exhaust system	Check or repair it
	Clogged air filter element	Replace or clean it
	Contaminated or damaged turbocharger	Repair or replace it
	Leakage of air from the discharging part of the compressor shaft	Check or repair it
	Deformed or damaged intake unit hose	Replace it
	Poor clamping state	Adjust and tighten the clamp
	Contaminated or damaged air filter	Replace and check if the impeller of the turbocharger is damaged
	Poor turbo actuator operation	Replace the turbocharger
	Leakage from the engine block and the exhaust manifold	Check the engine
	Contaminated blowby gas and abnormal oil amount	Check the turbo impeller and the turbo intake outlet
	Large gap of the turbocharger wheel, causing interference with the wall	Check if there is any sand or metallic foreign substance
	Damaged turbocharger wheel	Check if there is any sand or metallic foreign substance
	Damaged wheel and shaft of the turbocharger	Check if there is any sand or metallic foreign substance
Poor rotating force of the turbocharger wheel	Check if there is any sand or metallic foreign substance	
Oil leakage	Deformed or damaged intake unit hose	Replace it
	Poor clamping state	Adjust and tighten the clamp
	Contaminated or damaged air filter	Replace and check if the impeller of the turbocharger is damaged
	Leakage of coolant from the turbocharger or oil from the oil hose	Replace the hose and the gasket
	Poor turbo actuator operation	Replace the turbocharger



## 9. Intake/Exhaust system

Phenomenon	Causes	Troubleshooting
Oil leakage	Leakage from the engine block and the exhaust manifold	Check the engine
	Contaminated blowby gas and abnormal oil amount	Check the turbo impeller and the turbo intake outlet
	Large gap of the turbocharger wheel, causing interference with the wall	Check if there is any sand or metallic foreign substance
	Damaged turbocharger wheel	Check if there is any sand or metallic foreign substance
	Damaged wheel and shaft of the turbocharger	Check if there is any sand or metallic foreign substance
	Poor rotating force of the turbocharger wheel	Check if there is any sand or metallic foreign substance
Oil consumption	Poor clamping state	Adjust and tighten the clamp
	Leakage of coolant from the turbocharger or oil from the oil hose	Replace the hose and the gasket
	Leakage from the engine block and the exhaust manifold	Check the engine
	Contaminated blowby gas and abnormal oil amount	Check the turbo impeller and the turbo intake outlet
	Large gap of the turbocharger wheel, causing interference with the wall	Check if there is any sand or metallic foreign substance
	Damaged turbocharger wheel	Check if there is any sand or metallic foreign substance
	Damaged wheel and shaft of the turbocharger	Check if there is any sand or metallic foreign substance
	Poor rotating force of the turbocharger wheel	Check if there is any sand or metallic foreign substance

## 9. Intake/Exhaust system

Phenomenon	Causes	Troubleshooting
Black and white emissions	Deformed or damaged intake unit hose	Replace it
	Contaminated or damaged air filter	Replace and check if the impeller of the turbo-charger is damaged
	Leakage of coolant from the turbocharger or oil from the oil hose	Replace the hose and the gasket
	Poor turbo actuator operation	Replace the turbocharger
	Contaminated blowby gas and abnormal oil amount	Check the turbo impeller and the turbo intake outlet
	Large gap of the turbocharger wheel, causing interference with the wall	Check if there is any sand or metallic foreign substance
	Damaged turbocharger wheel	Check if there is any sand or metallic foreign substance
	Damaged wheel and shaft of the turbocharger	Check if there is any sand or metallic foreign substance
	Poor rotating force of the turbocharger wheel	Check if there is any sand or metallic foreign substance
Blue emissions	Leakage from the engine block and the exhaust manifold	Check the engine
Too much fog	Oil leakage to the turbine or compressor	Repair or replace it
	Worn or damaged seal ring due to worn bearing	Repair or replace it
Too much exhaust emissions	Clogged air filter element	Replace or clean it
	Clogged air duct	Check or repair it
	Air leakage from the intake system	Check or repair it
	The turbocharger cannot rotate because of burning	Repair or replace it
	A turbine blade or compression wing contacts with the other one or is damaged	Repair or replace it
	Deformed or clogged exhaust system pipe	Check or repair it

### How to maintain turbocharger

#### 1. Cautions for engine operation

- 1) Observe the followings when starting, operating, and stopping an engine.

Item	Cautions	Reasons
Starting an engine	Check the oil amount	
	Therefore, start the engine with the starter motor to check the rise of oil pressure (until the graduation of the oil pressure gauge moves or the pressure indicator lamp is turned on).	Overhasty start of engine leads to engine rotation without lubricating turbocharger and other engine parts, causing abnormal wear or burning of bearings.
	If you replace oil, oil filter cartridge, or lubrication system parts or use an engine in cold areas, or the engine has stopped for a long period, loosen the oil pipe joint at the inlet of the turbocharger and run the starter motor until oil flows out. After completing the work, tighten the oil pipe joint again and start the engine.	When an engine has stopped or kept cold for a long period, circulation of oil in the pipe gets poor.
After starting an engine	Operate the engine at idle for five minutes from starting it.	When the engine is suddenly loaded while the engine and the turbocharger have not been smoothly rotated after starting the engine, parts with insufficient oil may be burnt.
	Check if oil, gas, or air is leaked from each part. If so, take proper action.	Leakage of oil, gas, or air (especially oil) reduces oil pressure and loss of oil cause burning of bearings.
During Operation	check the following.	
	Oil pressure At idle: 1.5 ~ 3.0 kg/cm <sup>2</sup> Fully loaded: 3.0 ~ 5.5 kg/cm <sup>2</sup>	Too low oil pressure causes abnormal wearing or burning of bearings. Too high oil pressure causes oil leakage.
	When abnormal noise or vibration occurs, slowly reduce the rotate count until the engine stops and then figure out the causes.	Operating an engine with noise or vibration may cause irreversible damage of the engine.
Stopping an Engine	Operate the engine at idle for five minutes before stopping it.	Sudden engine stop after operating the engine under high load allows the heat from the red-heated turbine blade to be delivered to the bearing system. Then oil burns and the bearing metal and rotation shaft are burnt.

#### 2. Cautions for Maintenance

- 1) When the RPM is rapidly increased after starting the engine, the journal bearings in the crankshaft is excessively rotated, the crankshaft is rotated at excessive speed before the journal bearing of the crankshaft is lubricated fully. If the turbocharger rotates in this situation, bearings are not smoothly cooled and lubricated, causing bearing burn and damage of the related parts.
- 2) Please operate the engine for two minutes or more in order to lubricate the turbocharger fully after replacing the engine oil or oil filter.
- 3) If an engine has been operated at high speed for a long period, fully operate the engine at idle and then stop the engine. Otherwise, the turbine wheel continuously runs without oil pressure in the turbocharger. Therefore, no oil film is created on the center bearings and the journal bearings of the turbocharger, causing bearing, wearing out and shortening of the turbocharger lifetime.
- 4) If an engine is not operated for a long period during cold weather or in areas with cold climate, operate the engine at idle after starting the engine until the engine oil pressure is normal.

## 9. Intake/Exhaust system

---

- 5) The turbocharger turbine spins at high speed of 50,000 ~ 200,000 rpm. Therefore, lubrication of bearings may determine the turbocharger lifetime. Please use only recommended genuine engine oil and check and replace the engine oil periodically.
- 6) Prolonged usage of contaminated air cleaner may cause a critical damage of the turbocharger. Regularly check and replace the air cleaner.
- 7) A turbocharger is a very complex and precise part. Only certified and skilled technicians should work on it.
- 8) If a turbocharger is operated without intake and exhaust pipe, serious human injury may occur and critical faults of the engine performance may occur. Please operate a turbocharger only when all of parts are exactly mounted on the specified position.
- 9) Do not lift up a turbocharger by grabbing the actuator. The actuator may be damaged because of the weight of the turbocharger.
- 10) The weight of a turbocharger is about 4.0 kg or more. To lift up a turbocharger for installing or removing it, the worker should lower the center of gravity or press his body close to the turbocharger. Otherwise, worker may drop the turbocharger, causing damage of the part and injury.

## 9. Intake/Exhaust system

### Inspection items during disassembly/assembly of turbocharger

No.	Inspection items	Possible problem						Action
		Noise	Power drop	Oil leakage	Oil consumption	White/Black smoke	Blue smoke	
Before removal								
1	Is the intake hose torn or deformed?	<input type="radio"/>	<input type="radio"/>	<input type="radio"/>	<input type="radio"/>	<input type="radio"/>	<input type="radio"/>	Replace hose
2	Is the clamp tightened firmly?	<input type="radio"/>	<input type="radio"/>	<input type="radio"/>	<input type="radio"/>	<input type="radio"/>	<input type="radio"/>	Tighten bolt/nut correctly
3	Is the air filter intact?	<input type="radio"/>	<input type="radio"/>	<input type="radio"/>	<input type="radio"/>	<input type="radio"/>	<input type="radio"/>	Replace air filter and check turbocharger impeller for damage
4	Does turbocharger or oil hose leak?	<input type="radio"/>	<input type="radio"/>	<input type="radio"/>	<input type="radio"/>	<input type="radio"/>	<input type="radio"/>	Replace hose and gasket
5	Is gas leaked from exhaust manifold gasket?	<input type="radio"/>	<input type="radio"/>	<input type="radio"/>	<input type="radio"/>	<input type="radio"/>	<input type="radio"/>	Replace nut and gasket
6	Do solenoid valve and EGR system intact?	<input type="radio"/>	<input type="radio"/>	<input type="radio"/>	<input type="radio"/>	<input type="radio"/>	<input type="radio"/>	Replace solenoid and EGR valve
7	Does the turbocharger actuator operate correctly?	<input type="radio"/>	<input type="radio"/>	<input type="radio"/>	<input type="radio"/>	<input type="radio"/>	<input type="radio"/>	Replace turbocharger
During removal								
1	Is there a sign of leak between the engine block and exhaust manifold?	<input type="radio"/>	<input type="radio"/>	<input type="radio"/>	<input type="radio"/>	<input type="radio"/>	<input type="radio"/>	Check engine
2	Is the amount of oil and foreign material led with blow-by gas normal?	<input type="radio"/>	<input type="radio"/>	<input type="radio"/>	<input type="radio"/>	<input type="radio"/>	<input type="radio"/>	Check turbocharger impeller and turbocharger intake air outlet
3	Is there a sign of interference of the wheel with the wall due to excessive play of the wheel?	<input type="radio"/>	<input type="radio"/>	<input type="radio"/>	<input type="radio"/>	<input type="radio"/>	<input type="radio"/>	Check for foreign materials (sand, metallic object)
4	Is the wheel damaged?	<input type="radio"/>	<input type="radio"/>	<input type="radio"/>	<input type="radio"/>	<input type="radio"/>	<input type="radio"/>	Check for foreign materials (sand, metallic object)
After removal								
1	Is the wheel damaged or is the shaft broken?	<input type="radio"/>	<input type="radio"/>	<input type="radio"/>	<input type="radio"/>	<input type="radio"/>	<input type="radio"/>	Check for foreign materials (sand, metallic object)
2	Does the wheel rotate properly?	<input type="radio"/>	<input type="radio"/>	<input type="radio"/>	<input type="radio"/>	<input type="radio"/>	<input type="radio"/>	

## 9. Intake/Exhaust system

### Turbocharger inspection

#### 1. Daily inspection and service

It is important to handle the engine and maintain its optimum condition according to the instructions as the performance of the turbocharger is highly affected by the maintenance condition of the engine.

#### 1) Intake system

In the intake system, the air filter should be maintained with care. For a wet type air filter, if the oil level is below the specified level, its filtering performance is deteriorated. On the other hand, if the oil level is too high, it sucks in oil and contaminates the case. Especially, if the rotor is contaminated, the precisely adjusted balance is destroyed and the bearing is applied with large force, resulting in vibration, seizure and abnormal wear. Therefore, the air filter should be well-maintained and handled with care. A dry air filter should feature low possible intake air restriction.

#### 2) Exhaust system

If exhaust gas is leaked from the exhaust pipe or turbocharger connection in the exhaust system, the turbocharger's performance is deteriorated. Extra care is needed to prevent a gas leak and seizure. A heat resisting steel nut is used for parts, which can become hot during driving, such as the turbine housing. Make sure not to mix it with a general nut, and apply screw's anti-seize compound to the specified mounting nut.

#### 3) Lubrication system

In the lubrication system, the oil quality and the cartridge replacement interval of the oil filter should be monitored with care. Degraded engine oil can affect not only the engine body, but also the turbocharger negatively.

#### 2. Periodic inspection and service

Check the turbocharger for its condition and contamination periodically.

#### 1) How to check rotating condition of rotating part

When checking the rotating condition of a rotating part, check for abnormal noise. When using a sound bar, touch the turbocharger housing with its tip and rev up the engine slowly. If a high pitch note is continuously heard, it is abnormal. If abnormal condition is found, it is possible that the bearing or rotating part is defective. In this case, replace or repair the turbocharger.

#### 2) How to check play of rotating part

Separate the turbocharger from the engine and check the axial play and circumferential play of the rotating part. When separating the turbocharger, make sure to seal the oil inlet and outlet with plastic tape.

#### • Axial play of rotating part

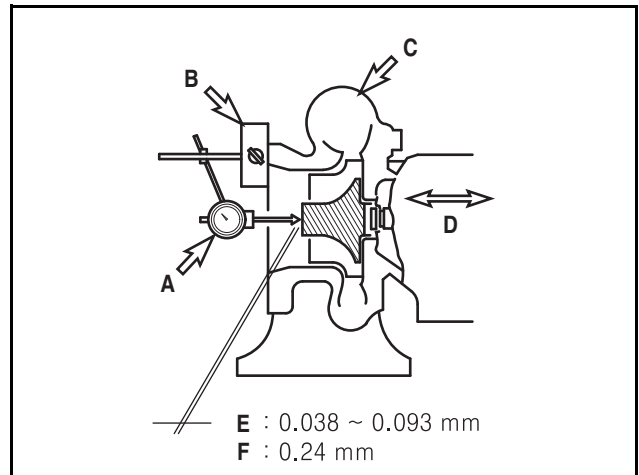

EDL022074B

- |                        |   |
|------------------------|---|
| A. Dial gauge          | D. Move the turbine shaft in the axial direction. |
| B. Magnet vice         | E. Service standard (0.038 - 0.093 mm)            |
| C. Turbine compartment | F. Wear limit (0.24 mm)                           |

#### • Circumferential play of rotating part

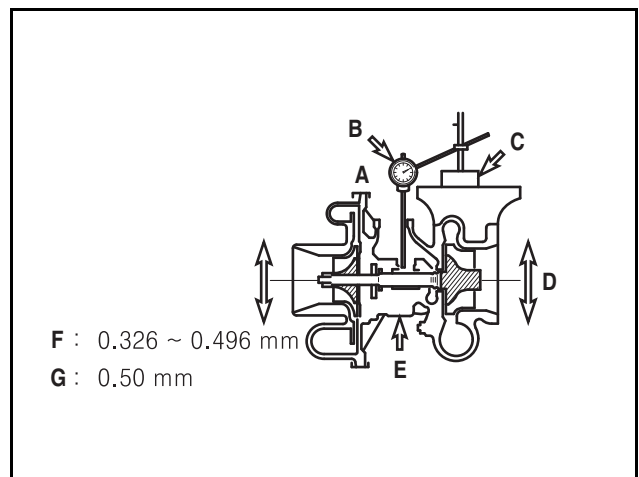

EDL022075B

- |                |   |
|----------------|---|
| A. Oil outlet  | D. Move the turbine shaft to the left and right in the circumferential direction. |
| B. Dial gauge  | E. Standard circumferential play (0.326 - 0.496 mm)                               |
| C. Magnet vice | F. Standard wear (0.50 mm)  |

• If the axial or circumferential play is over the wear limit, replace or remove and repair the turbocharger.

#### 3) Tips for turbocharger disassembly and inspection

Remove the turbocharger from the engine to clean or check it. Make sure to seal the oil inlet and outlet with plastic tape after its removal.

#### 4) Cautions for turbocharger installation

When or after installing the turbocharger to the engine, make sure keep the followings: Make sure that no foreign material enters the turbocharger.

- Lubrication system
  - Before installation to the engine, add new oil through the oil filler hole and turn the turbine shaft with a hand to lubricate the journal bearing and thrust bearing.
  - Clean the pipes between the engine and oil inlet and between the pipe and oil outlet thoroughly and check them for damage and foreign materials.
  - Tighten each connection of the oil pipes firmly to prevent an oil leak.
- Intake system
  - Check if there is no foreign material in the intake system.
  - Install each connection of the intake system and air filter firmly to prevent an air leak.
- Exhaust system
  - Check if there is no foreign material in the exhaust system.
  - Make sure to use only heat resisting bolts and nuts. Be careful not to mix them with general bolts and nuts during assembly. Apply anti-seize compound to the bolt and nut before installing them.
  - Tighten each connection of the exhaust system firmly to prevent any gas leak.

## 9. Intake/Exhaust system

### EGR (Exhaust Gas Reduction) system

#### General information

The EGR (Exhaust Gas Recirculation) system recirculates a portion of exhaust gas back to the intake system to cool it down and supply it to the engine for re-combustion in order to reduce NOx emission.

To reduce NOx and other emissions from the engine, it circulates exhaust gas containing almost no oxygen toward the intake system to decrease the density of oxygen supplied to the engine and induce combustion at a low temperature. As a result, a reduced amount of NOx is produced.

This system is equipped with the EGR cooler to reduce the temperature of hot exhaust gas in order to reduce the amount of NOx and enhance engine combustion efficiency.

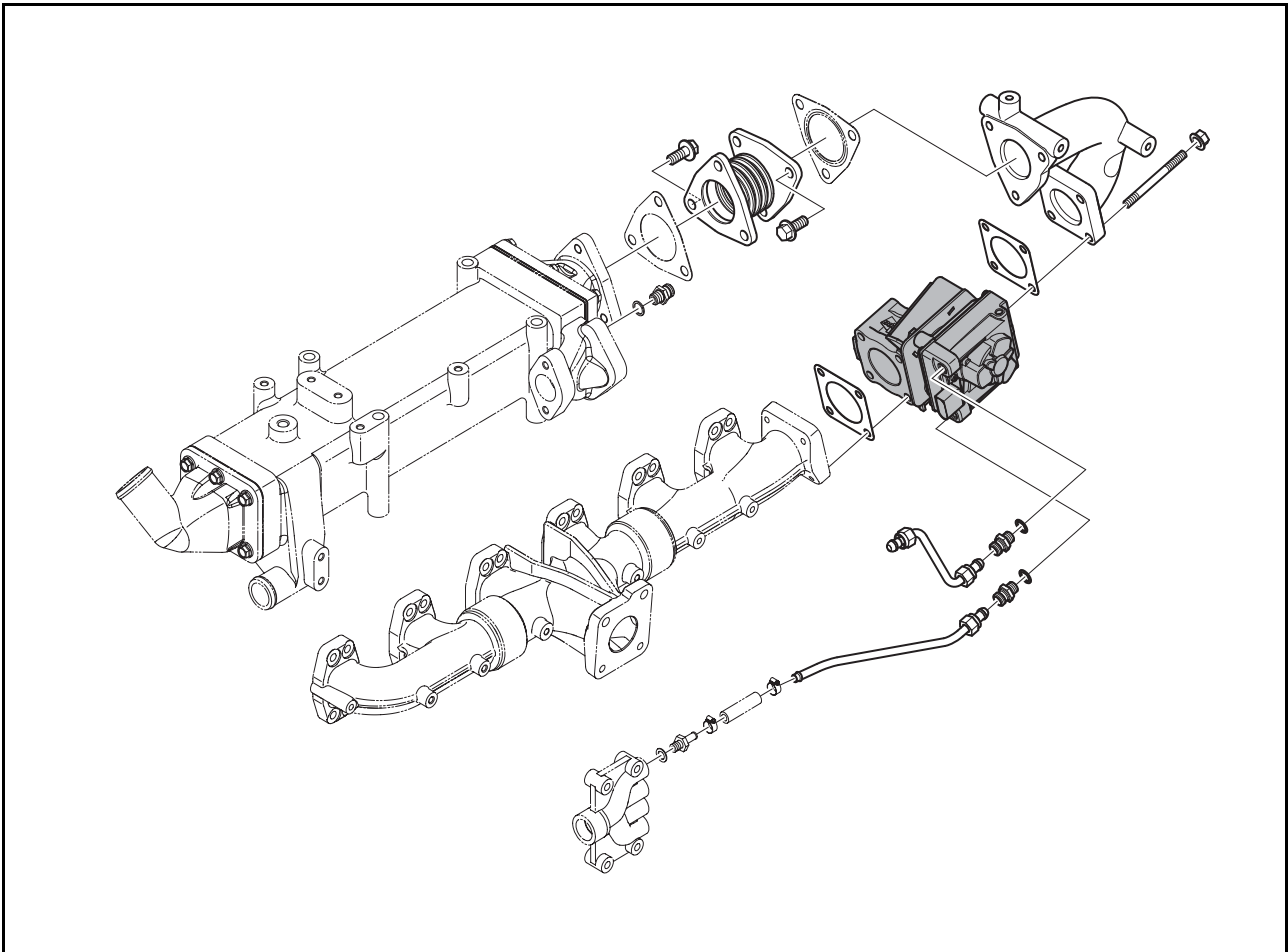

EK4OM089-E

#### [EGR]

##### 1. Overview

- 1) It is a device to recirculate a port of exhaust back to the engine according to the engine condition to reduce the amount of NOx production.
- 2) Exhaust gas is taken from the end of the exhaust manifold before it joins intake air, which is passed through the intercooler, and flows back to the engine.

##### 2. Major characteristics

- 1) It is equipped with the EGR cooler to decrease the temperature of exhaust gas.
- 2) To control the EGR rate, it is equipped with the electric EGR valve which uses a motor.



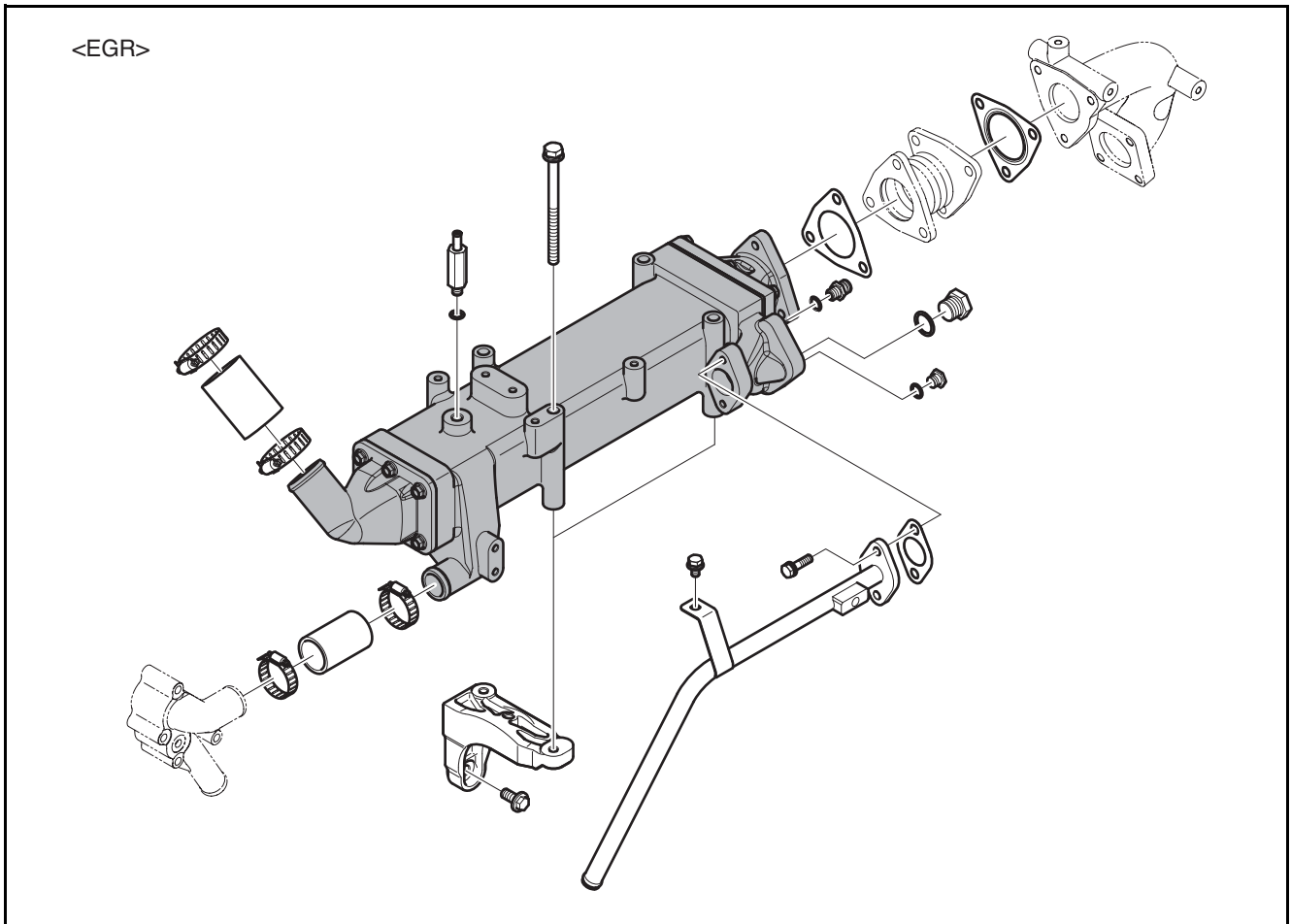

EK4OM088

### [EGR cooler]

#### 1. Overview of EGR cooler

- 1) It is a heat exchanger to reduce the temperature of recirculated exhaust gas with coolant.
- 2) The EGR cooler not only reduces the quantity of NO<sub>x</sub>, but also enhances combustion efficiency.

#### 2. Major characteristics of EGR

- 1) It is a typical tube type.

## 9. Intake/Exhaust system

---

### EGR disassembly and assembly

#### [Disassembly]

1. Remove the EGR valve and disconnect the elbow pipe.  
Note) Perform the process with the heat shield and bellows pipe removed.

---

### CAUTION

---

**As the EGR system is hot by exhaust gas, it should be disassembled after it is sufficiently cooled down.**

---

- 1) Remove the nut from the stud bolt.
  - 2) The cooling pipe should be disconnected to remove the EGR valve.
  2. Remove the EGR bracket.
- Note) Components available for removal after removal of exhaust manifold

#### [Assembly]

1. Assemble in the reverse order of disassembly.

---

### CAUTION

---

**Any used gasket should be replaced with a new one.**

---

### EGR cooler disassembly and assembly

#### [Disassembly]

1. As the EGR system becomes hot by exhaust gas while the engine is running, it should be disassembled after it is sufficiently cooled down.
- 1) Disconnect the coolant inlet/outlet pipes and hoses.
- 2) Remove the gas pipe outlet and hose.
- 3) Remove the heat shield.
- 4) Disconnect the bellows pipe.
- 5) Remove the EGR cooler mounting bolts.
- 6) Remove the EGR cooler from the EGR bracket.

#### [Assembly]

1. Assemble in the reverse order of disassembly.

---

### CAUTION

---

**Any used gasket should be replaced with a new one.**

---

### Intake pipe

#### Major air heater specifications

Note) Air heater: option

Rating	DC 22 V (95 A $\pm$ 10%)
Capacity	2.1 kW

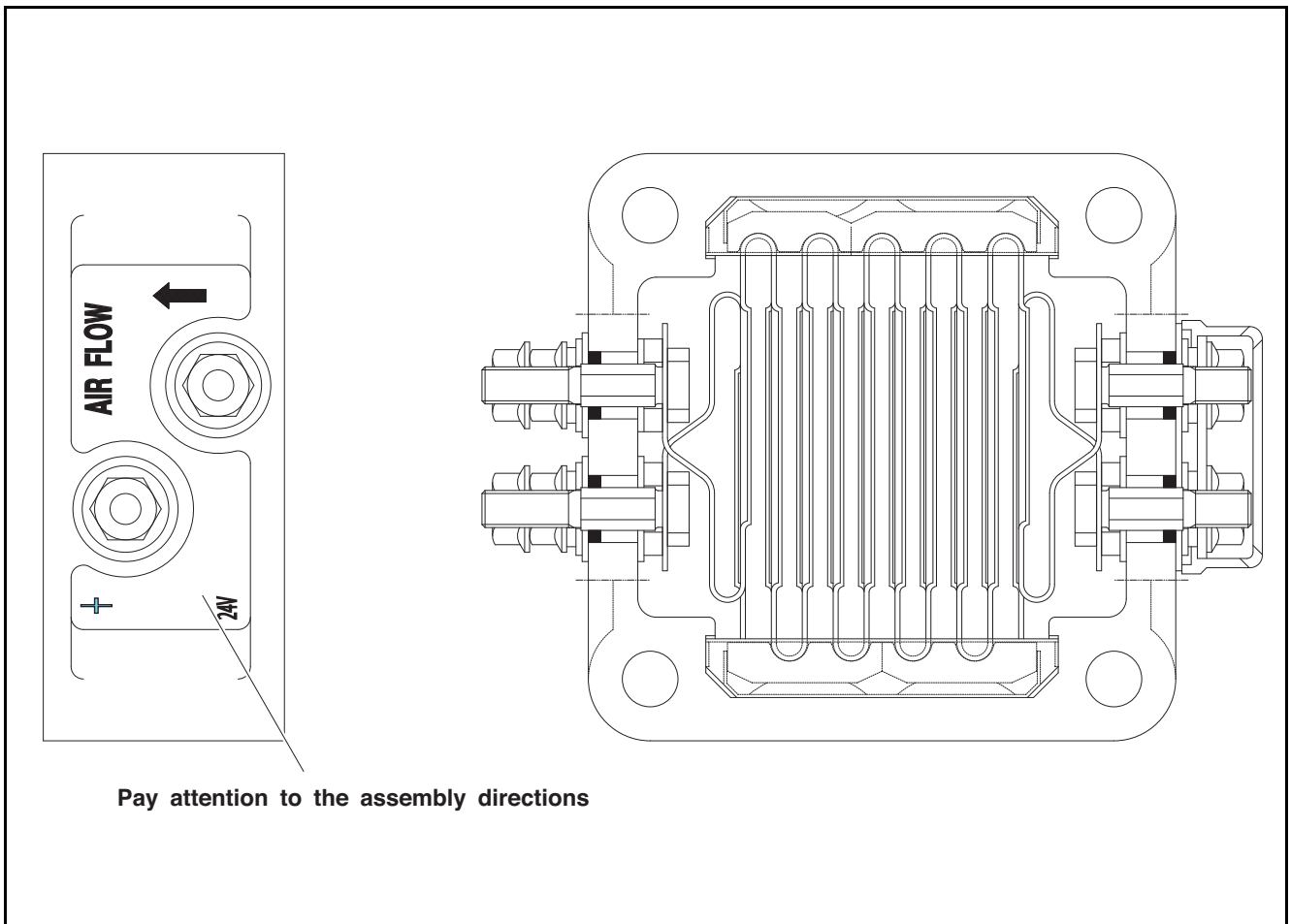

EJ9OM086-E

## 9. Intake/Exhaust system

---

# 10. Cylinder block/head

General information .....	175
General information .....	175
Cylinder block .....	176
Check of cylinder block .....	176
Cylinder head .....	177
Cylinder head disassembly .....	177
Cylinder head assembly .....	177
Cylinder head inspection .....	177
Valve .....	179
General information .....	179
Valve inspection .....	179
Valve guide inspection .....	179
Valve seat inspection .....	180
Valve spring inspection .....	181
Rocker arm .....	182
Rocker arm removal .....	182
Rocker arm installation .....	182
Rocker arm inspection .....	182
Rocker arm shaft inspection .....	182
Tappet and push rod .....	184
Valve tappet inspection .....	184
Push rod deflection inspection .....	184
Camshaft .....	185
Camshaft play .....	185
Camshaft inspection .....	185



### General information

#### General information

Doosan's diesel engine is an air-cooled electronic control diesel engine that uses cooling fans, overhead valve, and turbocharger.

The high-pressure fuel generated from the fuel high-pressure pump is stored in the common rail. When a driver operates the vehicle, fuel injection timing and optimum fuel amount are decided based on the data set in the Electronic Control Unit (ECU) and the solenoid valve of the injector installed in each engine cylinder is operated to inject fuel into the cylinder.

The cylinder block is made out of cast iron alloy and an anti-vibration and anti-noise crank case is mounted. In addition, the cylinder block and the timing gear case are designed as an integral structure to reduce the engine length and improve tightness. The cylinder head is an integral structure, too.

The forged crankshaft is an integral structure. The oil seals of the crankshaft and the flywheel prevents oil from permeating into the flywheel housing.

The connecting rod is forged and its big end part vertically separated. Like a piston, the connecting rod can be disassembled through the upper side of the cylinder. The alloy-type prefabricated bearing is used for the active part of the crankshaft and the connecting rod.

## 10. Cylinder block/head

---

### Cylinder block

#### Check of cylinder block

1. Cleanse the cylinder block and check if there is any cracked or damaged part with naked eye.
2. Replace the cylinder block if it is seriously cracked or damaged. Repair tiny cracks if existing.
3. Check if the oil path or coolant path is clogged or corroded.
4. Perform the hydrostatic test to check whether there is a crack or an air leakage.
5. Block the discharging outlets of the cooling water path and the oil path of the cylinder block and put pressure of  $4 \text{ kg/cm}^2$  on the inlet. Then sink the cylinder block in the  $70 \text{ }^\circ\text{C}$  water for 1 minute and check if air leaks.



## 10. Cylinder block/head

### Cylinder head

#### Cylinder head disassembly

1. After disassembling the cylinder head, keep it on a shelf in an organized way for later assembly.
2. Be careful not to damage the contact surface of the cylinder head gasket.
3. Remove the valve cotter, spring and spring seat using a valve spring compression tool.

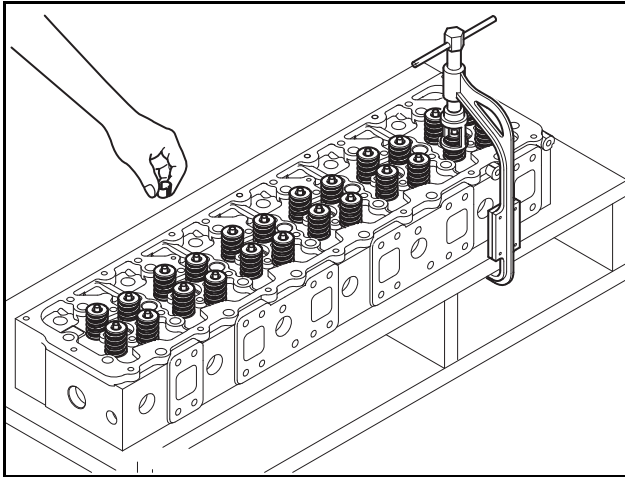

EJ9OM080

4. Pull out the intake and exhaust valves.
5. Keep the removed parts in order.
6. Remove the valve stem seal.

#### Cylinder head assembly

1. Clean the cylinder head thoroughly.
2. Replace the valve stem seal with a new one.
3. Use a special service tool to install the stem seal to the valve guide of the cylinder head.
4. Apply engine oil to the valve stem and valve guide, and install the valve.

### **⚠ CAUTION**

**Be careful not to damage the valve stem seal.**

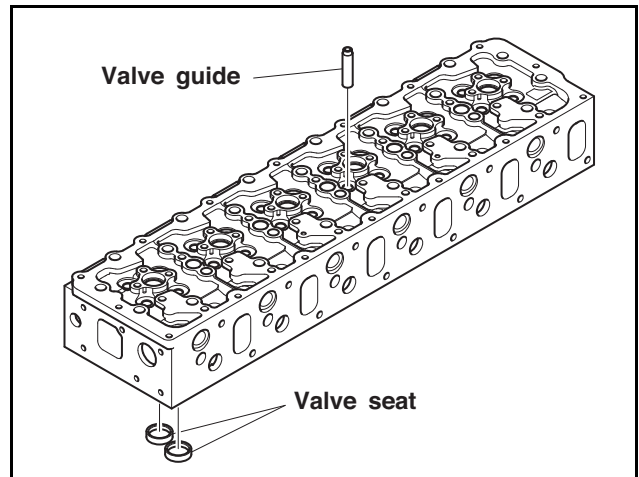

EE1OM069-E

5. Install the valve spring seat to the valve guide on the cylinder head.
6. Install the inner and outer valve springs and place the spring seat on the top.

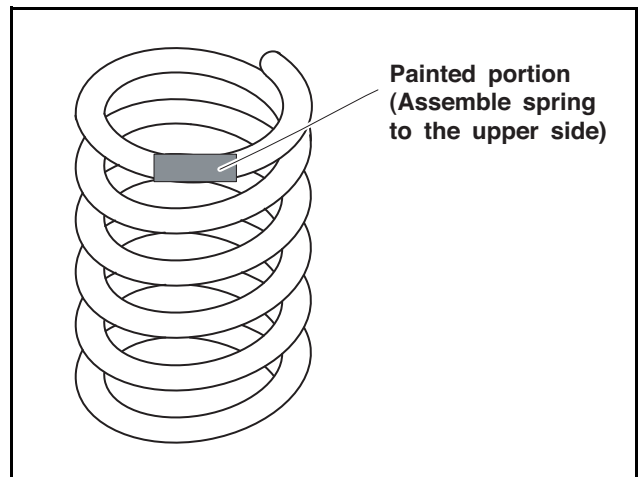

EE1OM070-E

7. While pressing the valve spring with the valve spring compression tool, insert the valve cotter to install the valve.
8. After installing the valve, tap the valve gently with a urethane hammer to check if it is firmly installed.

#### Cylinder head inspection

1. Cylinder head inspection
  - 1) Remove carbon from the bottom of the cylinder head.

### **⚠ CAUTION**

**Be careful not to scratch the valve seat surface.**

- 2) Visually check if the cylinder head is damaged.

# 10. Cylinder block/head

- 3) A minute scratch or damage that cannot be found with the naked eyes can be found through the hydraulic pressure test or magnetic particle test.
- 2. Bottom distortion
  - 1) Use a straightedge and feeler gauge to measure the distortion of the cylinder head in 6 directions.

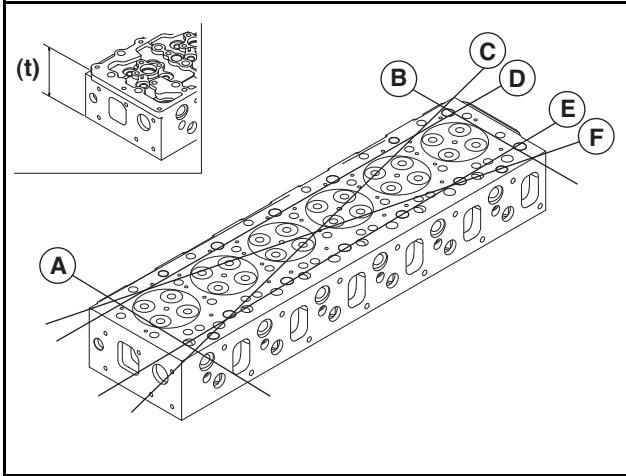

EH6OM028

- 2) If any measured value is over the allowable service limit, correct it with a fine sandpaper or grinder.
- 3) If it is over the allowable limit, replace the cylinder head.
  - Distortion and height of cylinder head

	Standard	Allowable limit
<b>Cylinder head bottom flatness</b>	0.08 mm or below	0.15 mm
<b>Head height: t</b>	104.9 - 105.1 mm	104.4 mm

- 3. Flatness
  - 1) Use a straightedge and feeler gauge to measure the flatness of the intake/exhaust manifold mounting surface of the cylinder head.

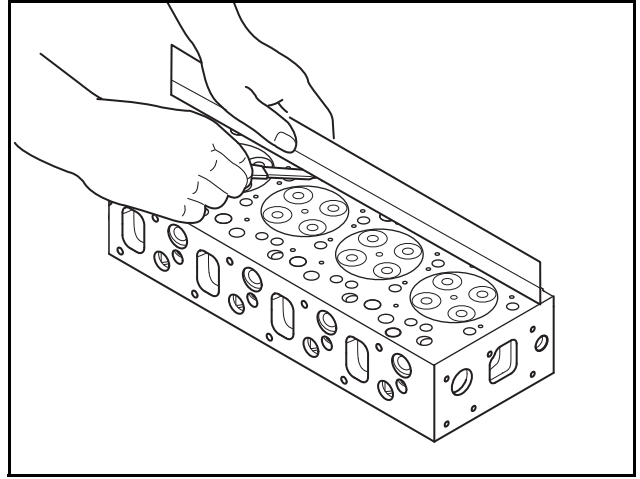

EH6OM029

Standard	Allowable limit
0.15 mm	0.3 mm

- 4. Flatness
  - 1) The hydraulic pressure test for the cylinder head is same to the test for the cylinder block.

## Valve

### General information

The overhead valve is operated through the cast iron tappet, push rod and rocker arm from the camshaft.

### Valve inspection

Wash the valve with clean engine oil and inspect it as follows:

1. Valve stem O.D.

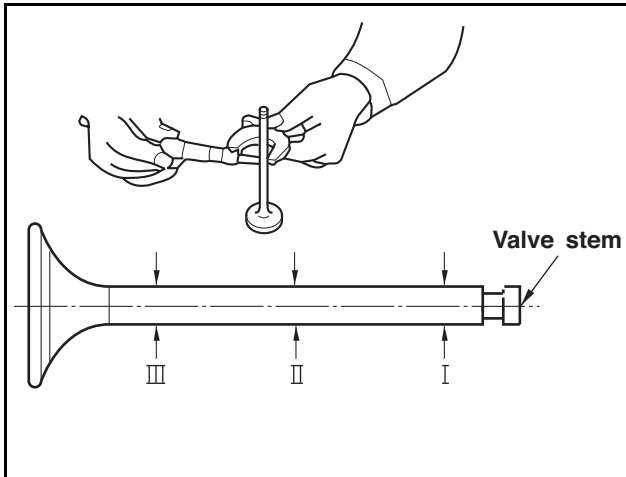

DV2213117A\_E

- 1) Measure the outside diameter of the valve stem at three location (upper, middle and lower points).
- 2) If the wear amount is over the allowable limit, replace the valve.

	Standard	Allowable limit
Intake valve stem	Ø6.963 - Ø6.977 mm	Ø6.93 mm
Exhaust valve stem	Ø6.950 - Ø6.964 mm	Ø6.91 mm

2. Valve seat contact surface

- 1) Check if the valve seat contact surface is scratched or damaged.
- 2) If necessary, correct the surface with sandpaper. If damage is severe, replace the seat.

3. Valve head thickness

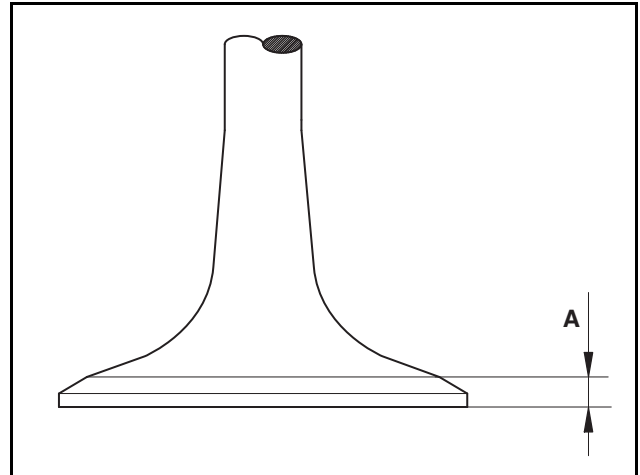

EE1OM066

- 1) Measure the thickness of the valve head.
- 2) If the measurement is below the allowable limit, replace the valve.

	Standard	Allowable limit
Intake valve (A)	3.3 - 3.7 mm	2.8 mm or below
Exhaust valve (A)	3.3 - 3.7 mm	2.8 mm or below

### Valve guide inspection

1. Install the valve to the cylinder head.
2. Measure the clearance between the valve guide and valve with motion of the valve.

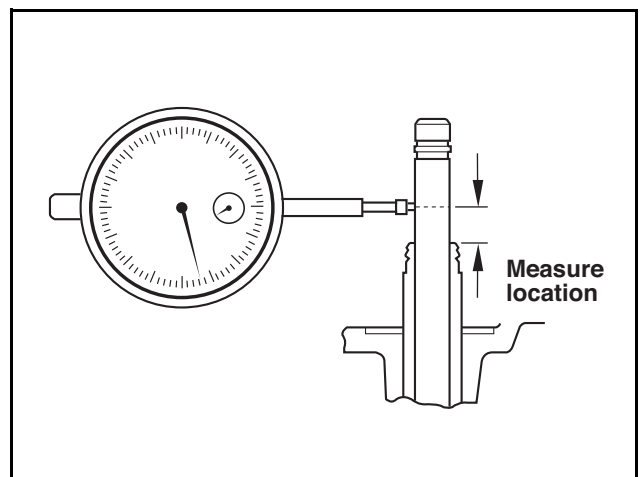

DV2213119A\_E

3. If the clearance is excessive, measure the size of the valve and replace either the valve or valve guide which is worn more.

# 10. Cylinder block/head

- Valve stem play

	Standard	Allowable limit
<b>Intake valve</b>	0.023 - 0.052 mm	0.1 mm
<b>Exhaust valve</b>	0.036 - 0.065 mm	0.15 mm

4. Install the valve to the cylinder head valve guide.
5. Use a special service tool to check if its center is aligned with the valve seat.

## Valve seat inspection

1. Contact area on contact surface

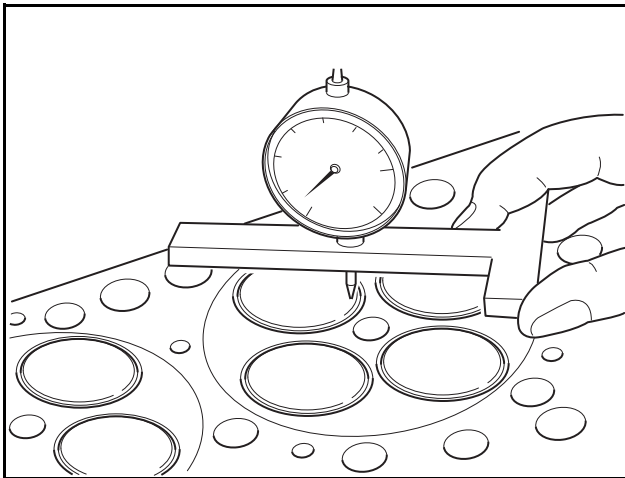

EE10M067

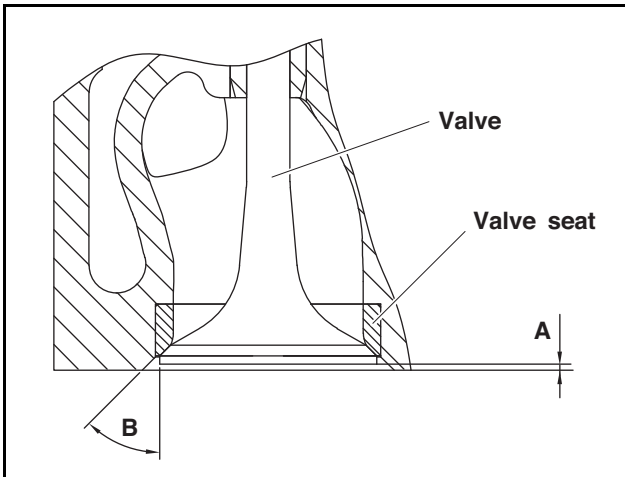

EE10M068-E

- 1) To check the wear level of the valve seat, measure the height of the contact surface from the intake/exhaust valves.
- 2) If the measurement is over the allowable limit, replace the seat.
- 3) Install the valve to the valve seat of the cylinder head.
- 4) Use a dial gauge to measure the amount of insertion of the valve from the bottom of the cylinder head.

- Valve step portion

	Standard	Allowable limit
<b>Intake valve (A)</b>	0.35 - 0.65 mm	0.85 mm
<b>Exhaust valve (A)</b>	0.35 - 0.65 mm	0.85 mm

- Valve angle

Intake valve (B)	Exhaust valve (B)
60°	45°

- 5) If the amount of valve insertion is over the allowable limit, replace the valve seat.
- 6) When removing the valve seat, arc weld two positions of the valve seat and use a special service tool to pull out the valve seat.

Note) When replacing the valve seat, it should be bored.

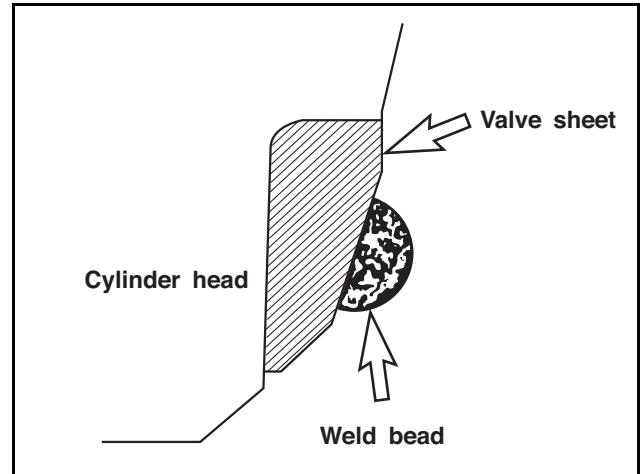

DV2213122A\_E

- 7) When installing the valve seat, put it in dry ice for approx. two hours to cool it down.
- 8) Use a bench press to press the valve seat into the cylinder head.
- 9) Apply abrasive to the valve head contact surface of the valve seat.
- 10) Rotate the valve to grind the valve seat until the valve is seated. Then, remove the abrasive thoroughly.

## 10. Cylinder block/head

### Valve spring inspection

1. Visually check the outside of the valve spring.
  - 1) Visually check if the valve spring is damaged. Replace it if necessary.
2. Check the free length of the valve spring.

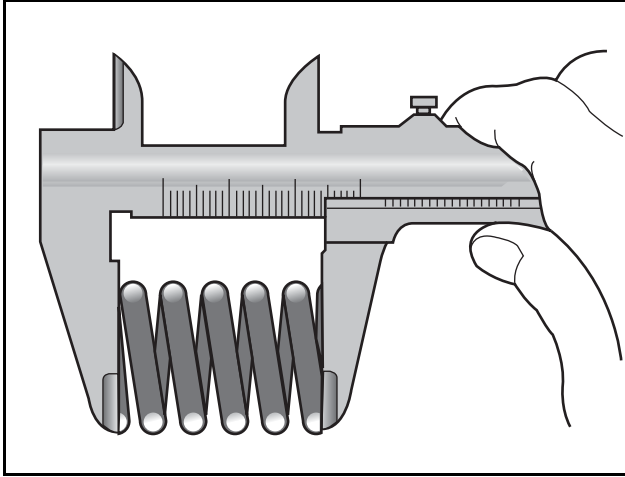

EA3M2033

- 1) Use vernier calipers to measure the free length of the valve spring.
- 2) If the measurement is below the standard value, replace the valve spring.

Free length of spring	Standard
Intake valve	54.5
Exhaust valve	54.5

3. Check the squareness of the valve spring.

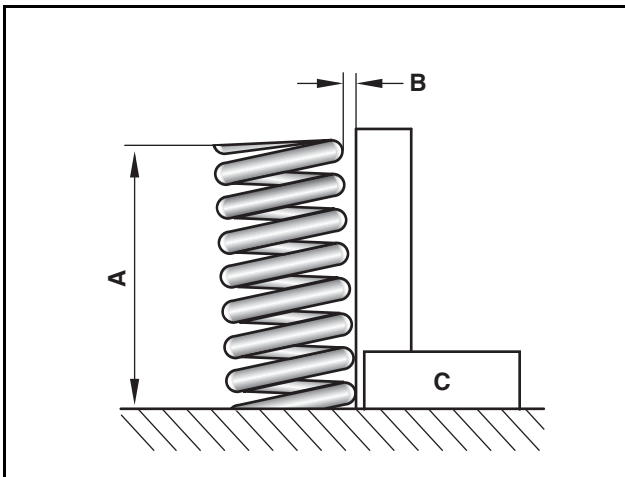

EDL022097A

- A. Free length      B. Squareness      C. Straight-edge

- 1) Use a surface plate and straightedge to measure the squareness of the valve spring.
- 2) If the measurement is over the allowable limit, replace the valve spring.

	Specification	Allowable limit
Valve spring squareness	1.4 mm or below	2.0 mm

4. Check the tension of the valve spring.

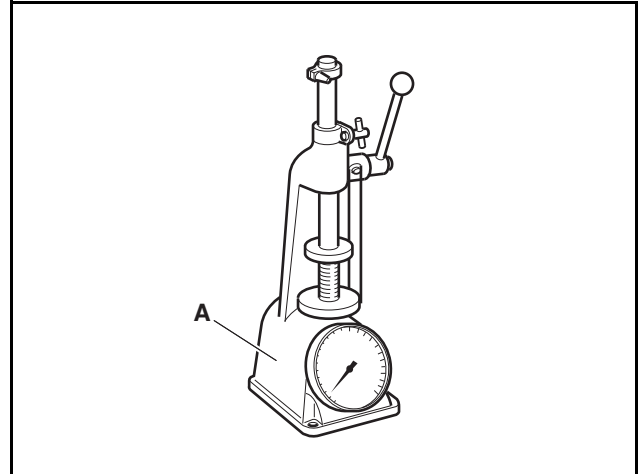

EDL022098B

- 1) Use a spring tester (A) to measure the tension of the valve spring.
- 2) If the measurement is below the allowable limit, replace the valve spring.

Item	Setting length	Spring tension	Allowable limit
Intake/exhaust valves	39.4 mm	28.8 kg	±2 kg
	29.67 mm	50 kg	±2 kg

# 10. Cylinder block/head

## Rocker arm

### Rocker arm removal

1. Use pliers to remove the snap rings from both ends of the rocker arm shaft.
2. Remove the washer, rocker arm bracket, rocker arm spring and rocker arm in order.

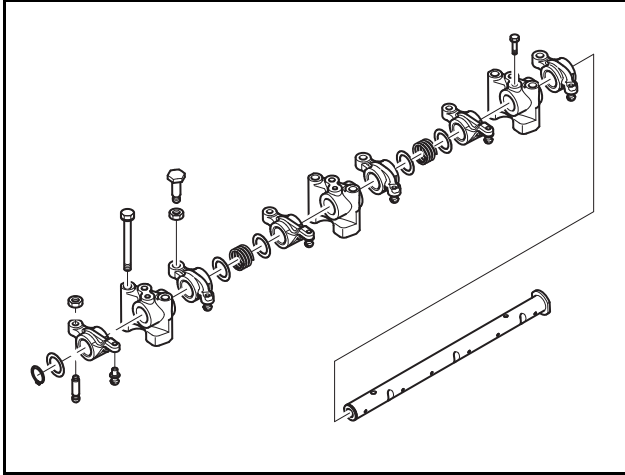

EE10M071

### Rocker arm installation

1. Install the rocker arm in the reverse order of its removal.

### ⚠ CAUTION

- Check if there is any foreign material in the oil feed hole of the rocker arm shaft. Wash it cleanly.
- Make sure to install the rocker arm in the correct position in the correct order.

### Rocker arm inspection

1. Visual inspection
  - 1) Visually check the surface of the adjusting screw cap assembly which moves in contact with the valve stem. Check if the surface is scratched or has worn layers.
  - 2) If the wear level is small, grind the surface with an oily whetstone or fine sandpaper. If the surface has severely worn layers, replace the rocker arm.

2. Rocker arm bushing I.D.

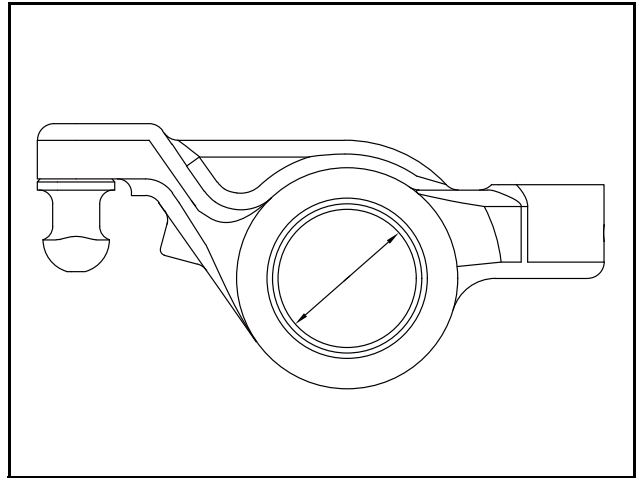

EE10M073

- 1) Use a micrometer or vernier calipers to measure the inside diameter of the rocker arm bushing.
- 2) Compare the measurement with the outside diameter of the rocker arm shaft. If the clearance is over the allowable limit, replace either the bushing or shaft which is worn more.

Standard	Allowable limit
Ø24.991 - Ø25.012 mm	Ø25.04 mm

	Standard	Allowable limit
Clearance between rocker arm and shaft	0.031 - 0.073 mm	0.14 mm or below

### Rocker arm shaft inspection

1. Deflection of rocker arm shaft

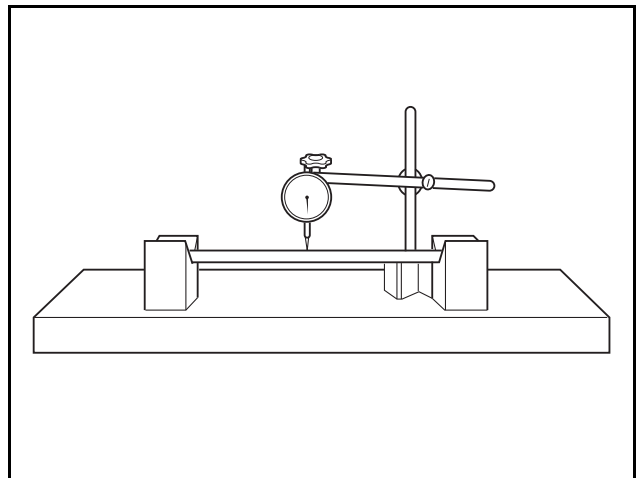

EDM20371

- 1) Place the rocker arm shaft on two V-blocks and use a dial gauge to measure the deflection of the shaft.

## 10. Cylinder block/head

---

- 2) If its deflection is minute, use a press to straighten it. If its deflection is over the allowable limit, replace it.

Allowable limit	0.1 mm
-----------------	--------

2. Rocker arm shaft O.D.

- 1) Use a O.D. micrometer to measure the outside diameter of the rocker arm shaft at the location where the rocker arm was installed.
- 2) If the measurement is over the allowable limit, replace the rocker arm shaft.

Standard	Allowable limit
Ø24.939 - Ø24.960 mm	Ø24.90 mm

# 10. Cylinder block/head

## Tappet and push rod

### Valve tappet inspection

1. Tappet clearance
  - 1) Measure the outside diameter of the tappet and the inside diameter of the tappet hole of the cylinder block.
  - 2) If the measurement is over the allowable limit, replace the tappet.

Standard	Allowable limit
0.028 - 0.069 mm	0.13 mm

2. Visual inspection of tappet

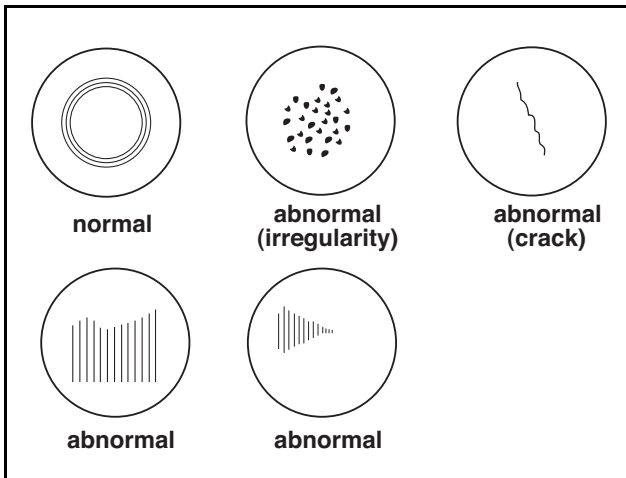

DV2213128A\_E

- 1) Visually check the surface of the tappet which moves in contact with the camshaft. Check if the surface is cracked, scratched or damaged.
- 2) If such damage is minute, grind the surface with an oily whetstone or fine sandpaper. If its surface has severely damaged, replace it.
3. Tappet O.D.

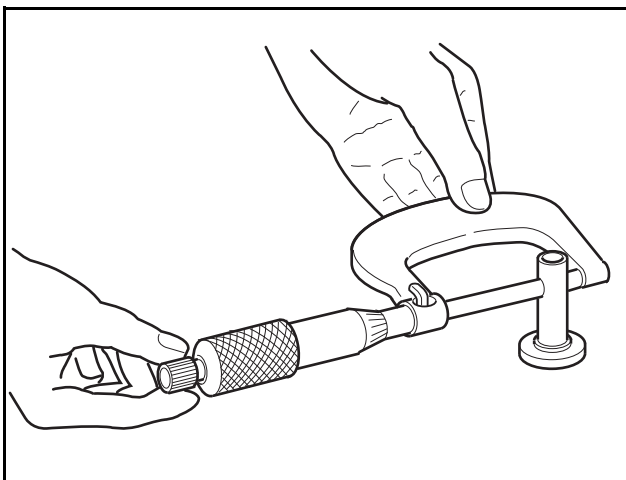

EDM2061I

- 1) Use a O.D. micrometer to measure the outside diameter of the tappet.

- 2) If the measurement is over the allowable limit, replace the tappet.

Standard	Ø27.962 - Ø27.982 mm
----------	----------------------

### Push rod deflection inspection

1. Place the push rod on the surface plate.
2. Measure its deflection with a feeler gauge while rolling it.

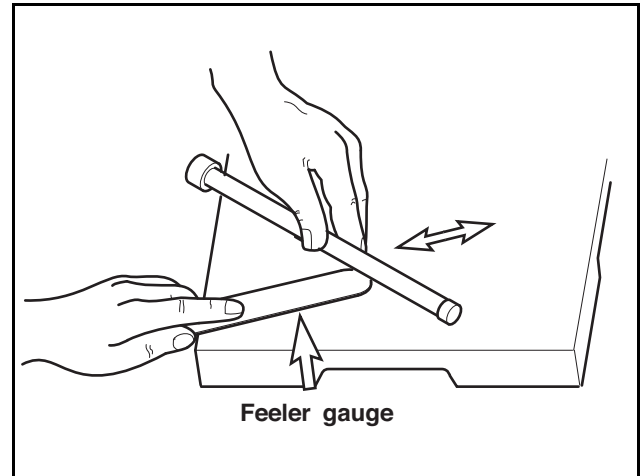

DV2213129A\_E

3. If the measurement is over the allowable limit, replace it.

Allowable limit	0.25 mm or below
-----------------	------------------

Push rod length	344 mm
-----------------	--------



## Camshaft

### Camshaft play

1. Move the camshaft gear to the opposite side of the cylinder block.
2. Use a feeler gauge to measure the clearance between the thrust plate and camshaft gear.

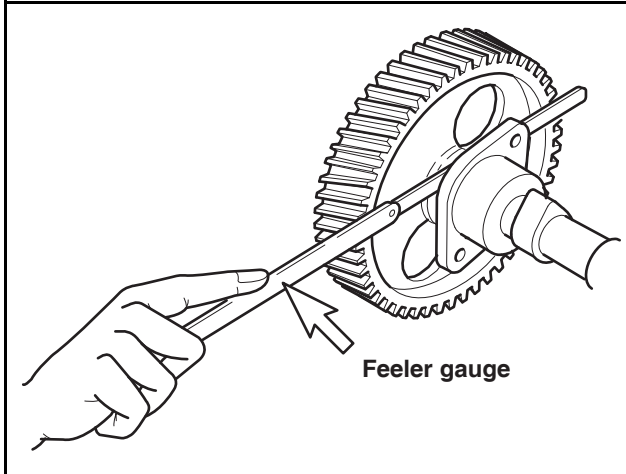

EA0M4067-E

3. If the play is excessive, replace the thrust plate.

Standard	Allowable limit
0.280 - 0.430 mm	0.5 mm

### Camshaft inspection

1. Measure the height of the cam lobe.

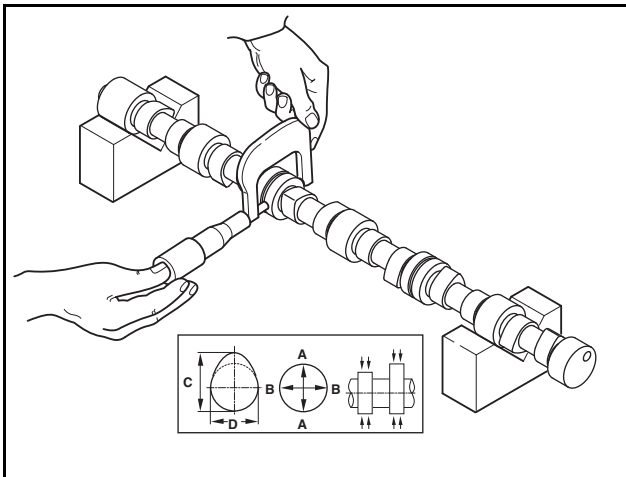

EH6OM030

- 1) Use a micrometer to measure the cam lobe height and journal diameter.
- 2) If the measurement is below the allowable limit, replace the camshaft.

		Standard	Allowable limit
Cam lobe height (C)	Intake	46.025 mm	45.73 mm
	Exhaust	47.782 mm	47.48 mm
Cam journal diameter (A & B)		Ø55.92 - Ø55.95 mm	Ø57.65 mm

2. Check the cam surface.
  - 1) Check if the cam surface is scratched or damaged.
  - 2) Minutely worn layers or small damage can be corrected with an oily whetstone or fine oily sandpaper. If damage is severe, replace it.
3. Clearance between camshaft and bearing

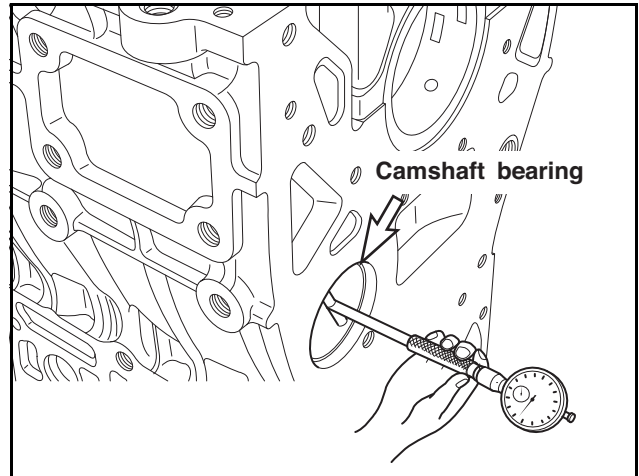

EH6OM031-E

- 1) Use an O.D. micrometer to measure the outside diameter of the camshaft bearing section.
- 2) Use a cylinder I.D. gauge to measure the inside diameter of the camshaft bearing, and compare the measurement result with the outside diameter of the camshaft to calculate the clearance.
- 3) If the measurement is over the allowable limit, replace the camshaft bearing.

Standard	Allowable limit
0.03 - 0.09 mm	0.18 mm

## 10. Cylinder block/head

---

### 4. Camshaft deflection

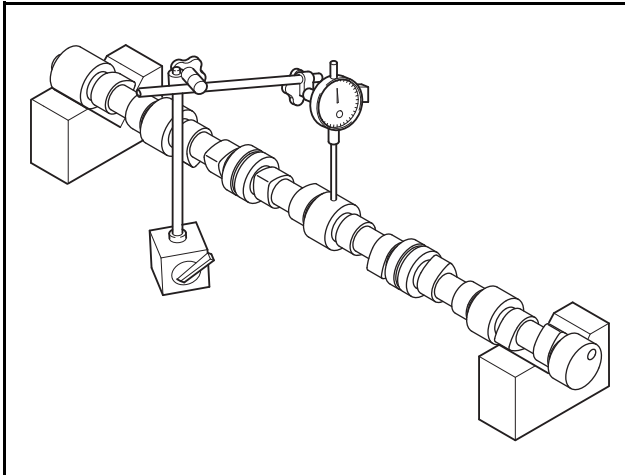

EH6OM032

- 1) Place the camshaft on two V-blocks.
- 2) Use a dial gauge to check the deflection of the camshaft.  
Correct it as necessary.
- 3) If its deflection is excessive and cannot be corrected, replace it.

Standard	Allowable limit
0.05 mm	0.15 mm

# 11. Electric system

Circuit diagram .....	189
General information .....	189
Engine connector .....	190
ECU (Engine Control Unit) engine connector .....	192
Switches and sensors .....	196
ECU (Electronic Control Unit) .....	196
Boost pressure and temperature sensor .....	199
Engine oil pressure and temperature sensor .....	199
Engine coolant temperature sensor .....	199
Common rail pressure sensor .....	200
Crankshaft speed sensor .....	201
Camshaft speed sensor .....	201
Pressure limiter valve .....	202
Accelerator pedal sensor .....	202
ECU (Electronic Control Unit) .....	203
ECU (Engine Control Unit) connector .....	203
ECU (Engine Control Unit) input/output .....	204
Operational conditions of Electronic Control Unit (ECU) .....	205
Starter .....	206
General information .....	206
Circuit diagram .....	207
Exhaust gas reduction .....	208
General information .....	208
Circuit diagram .....	209
Aftertreatment connector .....	210
Switches and sensors .....	211



### Circuit diagram

#### General information

1. It is possible to identify the circuit number for the connector and engine wire harness information.

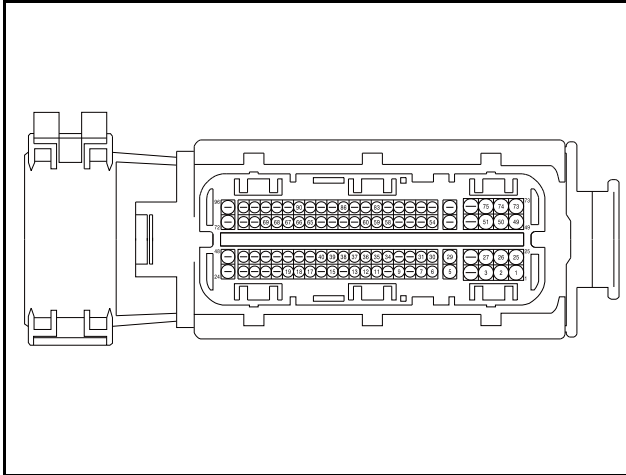

EK00337A

2. The wiring colors can be identified as follows:
  - 1) B: Black
  - 2) Brn: Brown
  - 3) G: Green
  - 4) Gra: Gray
  - 5) L: Blue
  - 6) O: Orange
  - 7) W: White
  - 8) Y: Yellow
  - 9) R: Red
3. The ECU pin No. means each pin number of an engine connector.
4. The sensor pin No. means each pin number of a sensor connector.

# 11. Electric system

## Engine connector

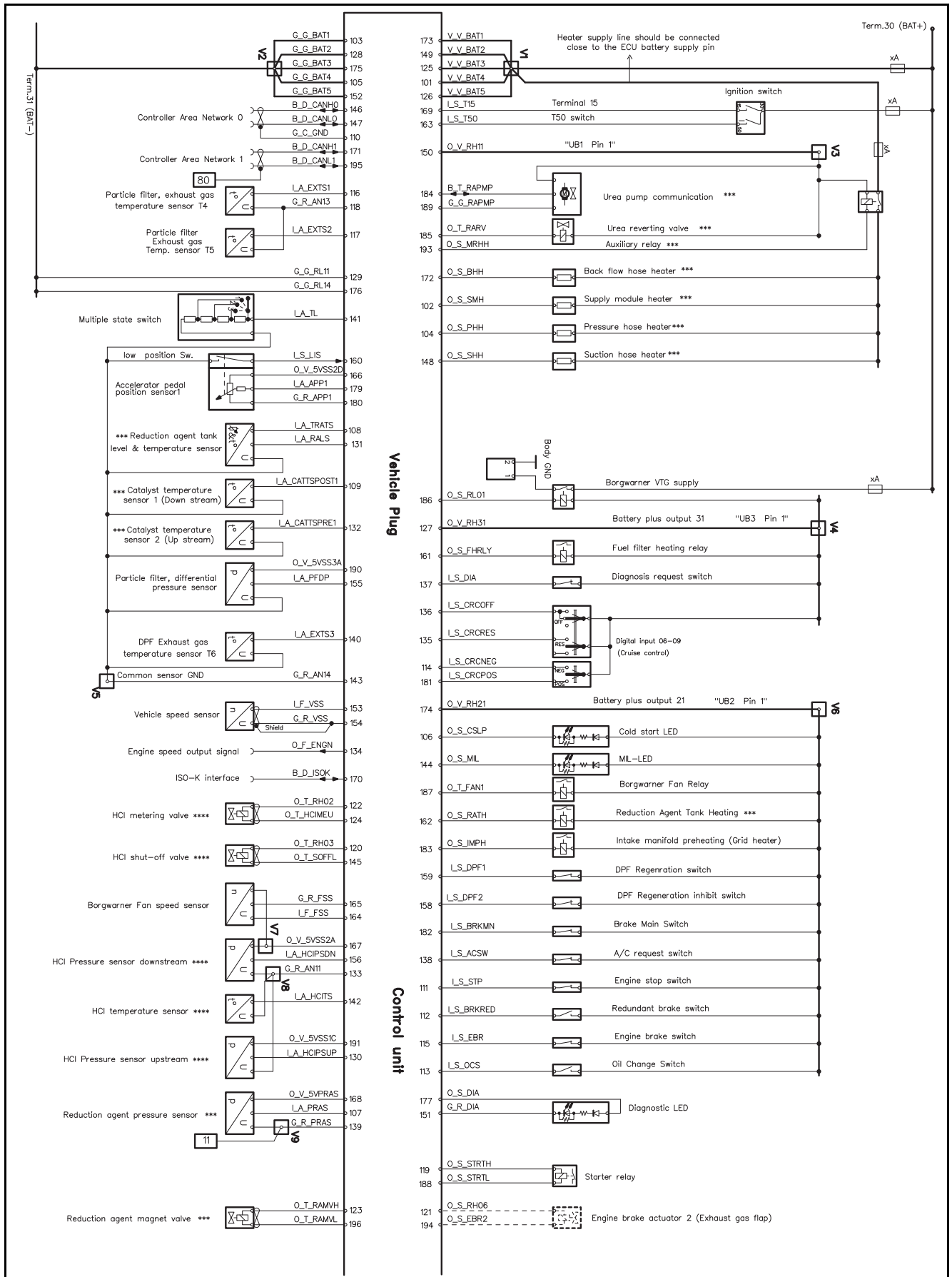

EK00335A

# 11. Electric system

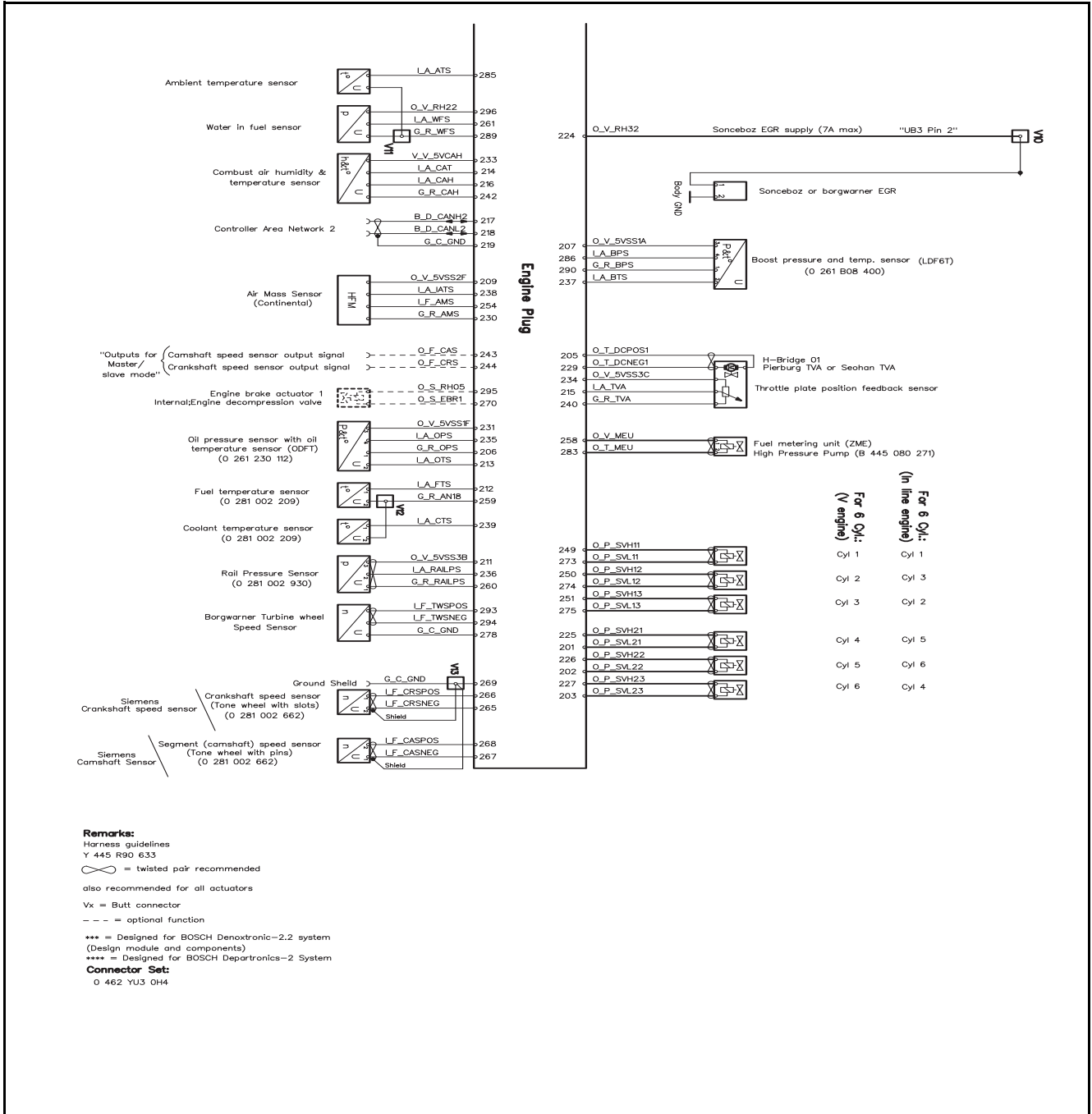

EK00336A

# 11. Electric system

## ECU (Engine Control Unit) engine connector

No.	Wire Label	Wire Kind	Size (mm <sup>2</sup> )	Color	Circuit Description	From	No.	To	No.	Remark
1	2.01	FLR7Y-A SN	1.50	Y	Injector 1, Bank 2 Low	ECU	1	Injector Connector (INJ)	10	Twist Pair (2.01/2.25)
2	2.02	FLR7Y-A SN	1.50	G	Injector 2, Bank 2 Low	ECU	2	Injector Connector (INJ)	12	Twist Pair (2.02/2.26)
3	2.03	FLR7Y-A SN	1.50	L	Injector 3, Bank 2 Low	ECU	3	Injector Connector (INJ)	8	Twist Pair (2.03/2.27)
4	2.05	FLR7Y-A SN	1.0	R	Throttle Plate Actuator Pos	ECU	5	Throttle Plate Actuator/Position Sensor (TVA)	6	Twist Pair (2.05/2.29)
5	2.06	FLR7Y-A SN	0.75	B	Oil Press/Temp Sensor GND	ECU	6	Oil Press Temp Sensor (OPTS)	1	
6	2.07	FLR7Y-A SN	0.75	O	Boost Press/Temp Sensor PWR	ECU	7	Boost Press Temp Sensor (BPTS)	3	
7	2.09	FLR7Y-A SN	0.75	R	HFM Sensor PWR	ECU	9	Inter Conn for Vehicle (ICV)	4	
8	2.11	FLR7YB33X SN	0.75	O	Rail Press Sensor PWR	ECU	11	Rail Press Sensor (RPS)	3	Shield 2.11/2.36
9	2.12	FLR7Y-A SN	0.75	R	Fuel Temp Sensor Signal	ECU	12	Fuel Temp Sensor (FTS)	1	
10	2.13	FLR7Y-A SN	0.75	Brn	Oil Temp Sensor Signal	ECU	13	Oil Press Temp Sensor (OPTS)	2	
11	2.15	FLR7Y-A SN	0.75	B	Throttle Plate Position Sensor SIG	ECU	15	Throttle Plate Actuator/Position Sensor (TVA)	5	
12	2.17	FLR7YB33X SN	0.75	O	Can 2 High	ECU	17	EGR Valve(EGR) (Pin 4)/Resistance(R120) (Pin 1)		Joint, Shield 2.17/2.18
13	2.18	FLR7YB33X SN	0.75	W	Can 2 Low	ECU	18	EGR Valve(EGR) (Pin 3)/Resistance(R120) (Pin 2)		Joint, Shield 2.17/2.18
14	2.19	FLR7Y-A SN	0.75	B	Can2 GND	ECU	19	2.17/2.18		Shield Drain (2.17/2.18)
15	2.25	FLR7Y-A SN	1.50	W	Injector 1, Bank 2 High	ECU	25	Injector Connector (INJ)	9	Twist Pair (2.01/2.25)
16	2.26	FLR7Y-A SN	1.50	W	Injector 2, Bank 2 High	ECU	26	Injector Connector (INJ)	11	Twist Pair (2.02/2.26)
17	2.27	FLR7Y-A SN	1.50	W	Injector 3, Bank 2 High	ECU	27	Injector Connector (INJ)	7	Twist Pair (2.03/2.27)
18	2.29	FLR7Y-A SN	1.0	Y	Throttle Plate Actuator Neg	ECU	29	Throttle Plate Actuator/Position Sensor (TVA)	2	Twist Pair (2.05/2.29)
19	2.30	FLR7Y-A SN	0.75	Brn	HFM Sensor GND	ECU	30	Inter Conn for Vehicle (ICV)	1	
20	2.31	FLR7Y-A SN	0.75	R	Oil Press/Temp Sensor Power	ECU	31	Oil Press Temp Sensor (OPTS)	3	
21	2.34	FLR7Y-A SN	0.75	W	Throttle Plate Position Sensor PWR	ECU	34	Throttle Plate Actuator/Position Sensor (TVA)	1	
22	2.35	FLR7Y-A SN	0.75	Y	Oil Press Sensor Signal	ECU	35	Oil Press Temp Sensor (OPTS)	4	
23	2.36	FLR7YB33X SN	0.75	W	Rail Press Sensor Signal	ECU	36	Rail Press Sensor (RPS)	2	Shield 2.11/2.36
24	2.37	FLR7Y-A SN	0.75	Y	Boost Temp Sensor PWR	ECU	37	Boost Press Temp Sensor (BPTS)	2	
25	2.38	FLR7Y-A SN	0.75	O	HFM Sensor Signal	ECU	38	Inter Conn for Vehicle (ICV)	2	



# 11. Electric system

No.	Wire Label	Wire Kind	Size (mm2)	Color	Circuit Description	From	No.	To	No.	Remark
26	2.39	FLR7Y-A SN	0.75	W	Coolant Temp Sensor Signal	ECU	39	Coolant Temp Sensor (CTS)	1	
27	2.40	FLR7Y-A SN	0.75	Brn	Throttle Plate Position Sensor GND	ECU	40	Throttle Plate Actuator/ Position Sensor (TVA)	3	
28	2.49	FLR7Y-A SN	1.50	W	Injector 1, Bank 1 High	ECU	49	Injector Connector (INJ)	1	Twist Pair (2.49/2.73)
29	2.50	FLR7Y-A SN	1.50	W	Injector 2, Bank 1 High	ECU	50	Injector Connector (INJ)	5	Twist Pair (2.50/2.74)
30	2.51	FLR7Y-A SN	1.50	W	Injector 3, Bank 1 High	ECU	51	Injector Connector (INJ)	3	Twist Pair (2.51/2.75)
31	2.54	FLR7Y-A SN	0.75	W	HFM Sensor Frequency Output	ECU	54	Inter Conn for Vehicle (ICV)	3	
32	2.58	FLR7Y-A SN	0.75	R	Fuel Metering Unit	ECU	58	Fuel Metering Unit (FMU)	1	Twist Pair (2.58/2.83)
33	2.59	FLR7Y-A SN	0.75	B	Fuel Temp/ Coolant Temp Sensor GND	ECU	59	Fuel Temp Sensor (FTS) (Pin 2)/ Coolant Temp Sensor (CTS) (Pin 2)		Joint
34	2.60	FLR7Y-A SN	0.75	B	Rail Press Sensor GND	ECU	60	Rail Press Sensor (RPS)	1	Shield Drain (2.11/2.36)
35	2.65	FLR7YB33X SN	0.75	O	Crankshaft Speed Sensor Neg	ECU	65	Crankshaft Speed Sensor (CRS)	2	Shield 2.65/2.66
36	2.66	FLR7YB33X SN	0.75	W	Crankshaft Speed Sensor Pos	ECU	66	Crankshaft Speed Sensor (CRS)	1	Shield 2.65/2.66
37	2.67	FLR7YB33X SN	0.75	Brn	Camshaft Speed Sensor Neg	ECU	67	Camshaft Speed Sensor (CAS)	2	Shield 2.67/2.68
38	2.68	FLR7YB33X SN	0.75	Y	Camshaft Speed Sensor Pos	ECU	68	Camshaft Speed Sensor (CAS)	1	Shield 2.67/2.68
39	2.69	FLR7Y-A SN	0.75	B	Crankshaft / Camshaft Sensor Shield	ECU	69	Crankshaft Speed Sensor (CRS)/ Camshaft Speed Sensor (CAS)	3	Shield Drain (2.65/2.66, 2.67/2.68)
40	2.73	FLR7Y-A SN	1.50	Gra	Injector 1, Bank 1 Low	ECU	73	Injector Connector (INJ)	2	Twist Pair (2.49/2.73)
41	2.74	FLR7Y-A SN	1.50	O	Injector 2, Bank 1 Low	ECU	74	Injector Connector (INJ)	6	Twist Pair (2.50/2.74)
42	2.75	FLR7Y-A SN	1.50	Brn	Injector 3, Bank 1 Low	ECU	75	Injector Connector (INJ)	4	Twist Pair (2.51/2.75)
43	2.83	FLR7Y-A SN	0.75	Brn	Fuel Metering Unit	ECU	83	Fuel Metering Unit (FMU)	2	Twist Pair (2.58/2.83)
44	2.86	FLR7Y-A SN	0.75	W	Boost Press Sensor Signal	ECU	86	Boost Press Temp Sensor (BPTS)	4	
45	2.90	FLR7Y-A SN	0.75	B	Boost Press/Temp Sensor GND	ECU	90	Boost Press Temp Sensor (BPTS)	1	
46	Vbat	FLR7Y-A SN	0.75	R	24V(Vbat)	Inter Conn for Vehicle (ICV)	6	EGR Valve (EGR)	1	
47	GND	FLR7Y-A SN	0.75	B	Ground	Inter Conn for Vehicle (ICV)	10	EGR Valve (EGR)	2	

## 11. Electric system

No.	Wire Label	Wire Kind	Size (mm2)	Color	Circuit Description	From	No.	To	No.	Remark
48	1.64	FLR7Y-A SN	0.75	O	Fan Speed Sensor Output (FSS Out)	Inter Conn for Vehicle (ICV)	11	Fan Clutch Connector (FAN)	1	
49	1.65	FLR7Y-A SN	0.75	B	Fan Speed Sensor GND	Inter Conn for Vehicle (ICV)	5	Fan Clutch Connector (FAN)	2	
50	1.67	FLR7Y-A SN	0.75	Y	Fan Speed Sensor Supply (U Sensor)	Inter Conn for Vehicle (ICV)	7	Fan Clutch Connector (FAN)	5	
51	1.74	FLR7Y-A SN	0.75	W	Solenoid Coil High (Coil +)	Inter Conn for Vehicle (ICV)	8	Fan Clutch Connector (FAN)	4	
52	1.87	FLR7Y-A SN	0.75	Brn	Solenoid Coil Low (Coil -)	Inter Conn for Vehicle (ICV)	12	Fan Clutch Connector (FAN)	3	
53	13B	FLR7Y-A SN	2.0	W	Start S	Inter Conn1 (INT1)	5	Start S (STS)	1	
54	99I	FLR7Y-A SN	8.0	B	Alternator E	ALT E (GND)	1	Engine Earth (EGND)	1	
55	4A	FLR7Y-A SN	8.0	W	Alternator B	ALT B (BAT)	1	KL4A		Splice KL4A
56	4J	FLR7Y-A SN	5.0	W	Alternator B	KL4A	S01	Inter Conn 3 (INT3)	1	Splice KL4A
57	4M	FLR7Y-A SN	5.0	W	Alternator B	KL4A	S01	Inter Conn 3 (INT3)	2	Splice KL4A
58	14A	FLR7Y-A SN	1.25	W	Alternator R	Inter Conn1 (INT1)	1	ALT R (R)	1	
59	9A	FLR7Y-A SN	2.0	W	Alternator I	Inter Conn1 (INT1)	2	ALT R (I(L))	1	
60	29C	FLR7Y-A SN	0.75	Y	Compressor +	Inter Conn1 (INT1)	3	Compressor (COMP)	+	
61	99H	FLR7Y-A SN	0.75	B	Compressor -	99I	S01	Compressor (COMP)	-	Splice 99I
62	99G	FLR7Y-A SN	0.75	B	Dioed 4A	Dioed 4 (DIO4)	A	99I		Splice 99I
63	29B	FLR7Y-A SN	0.75	W	Dioed 4K	Dioed 4 (DIO4)	K	29C		Splice 29C
64	1.23	FLR7Y-A SN	1.5	L	Dosing Valve High Side	Inter Conn for SCR (ICS)	1	Inter Conn 2 (INT2)	1	Twist Pair (1.23/1.96)
65	1.96	FLR7Y-A SN	1.5	B	Dosing Valve Low Side	Inter Conn for SCR (ICS)	2	Inter Conn 2 (INT2)	2	Twist Pair (1.23/1.96)
66	1.16	FLR7Y-A SN	0.75	Y	DOC Upstream (T4) Signal	Inter Conn for SCR (ICS)	3	Inter Conn 2 (INT2)	3	
67	1.18	FLR7Y-A SN	0.75	Brn	DOC Upstream (T4) Ground	Inter Conn for SCR (ICS)	4	Inter Conn 2 (INT2)	4	
68	1.32	FLR7Y-A SN	0.75	W	SCR Upstream signal	Inter Conn for SCR (ICS)	5	Inter Conn 2 (INT2)	5	





## 11. Electric system

No.	Wire Label	Wire Kind	Size (mm2)	Color	Circuit Description	From	No.	To	No.	Remark
69	1.43	FLR7Y-A SN	0.75	B	SCR Upstream ground	Inter Conn for SCR (ICS)	6	Inter Conn 2 (INT2)	6	
70	1.09	FLR7Y-A SN	0.75	R	SCR Downstream signal	Inter Conn for SCR (ICS)	7	Inter Conn 2 (INT2)	7	
71	301	FLR7Y-A SN	1.5	O	Master NOX sensor Ubatt	Inter Conn for SCR (ICS)	8	Inter Conn 2 (INT2)	8	
72	302	FLR7Y-A SN	1.5	Gra	Master NOX sensor GND	Inter Conn for SCR (ICS)	9	Inter Conn 2 (INT2)	9	
73	303	FLR7YB33X SN	0.75	O	Master NOX sensor CAN Low	Inter Conn for SCR (ICS)	11	Inter Conn 2 (INT2)	11	
74	304	FLR7YB33X SN	0.75	W	Master NOX sensor CAN High	Inter Conn for SCR (ICS)	10	Inter Conn 2 (INT2)	10	



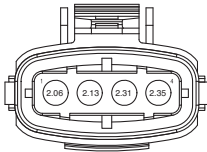
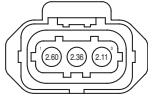

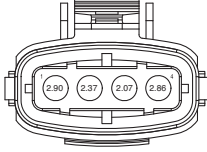
# 11. Electric system

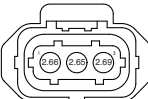
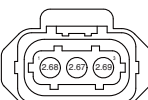
## Switches and sensors

### ECU (Electronic Control Unit)

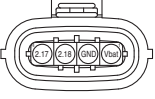
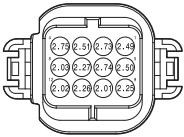
Shape	Symbol	Pin No.	Circuit name
Fuel Metering Unit 	FMU	2.58	Fuel metering unit (O_V_MEU)
		2.83	Fuel metering unit (O_T_MEU)
Oil Press Temp Sensor 	OPTS	2.06	Oil pressure/temperature sensor GND (G_R_OPS)
		2.13	Oil temperature sensor SIG (I_A_OTs)
		2.31	Oil pressure/temperature sensor voltage (V_V_5VSS1F)
		2.35	Oil pressure sensor SIG (I_A_OPS)
Rail Press Sensor 	RPS	2.60	Rail pressure sensor GND (G_R_RAILPS)
		2.36	Rail pressure sensor SIG (I_A_RAILPS)
		2.11	Rail pressure sensor voltage (V_V_5VSS3B)
Throttle Plate Actuator/Position Sensor 	TVA	2.34	Throttle valve voltage (V_V_5VSS3C)
		2.29	Throttle valve motor - (O_T_DCNEG1)
		2.40	Throttle valve GND (G_R_TVA)
		2.15	Throttle valve SIG (I_A_TVA)
		2.05	Throttle valve motor + (O_T_DCPOS1)
Boost Press Temp Sensor 	BPTS	2.90	Boost pressure/temperature sensor GND (G_R_BPS)
		2.37	Boost temperature sensor SIG (I_A_BTS)
		2.07	Boost pressure/temperature sensor voltage (V_V_5VSS1A)
		2.86	Boost pressure sensor SIG (I_A_BPS)
Coolant Temp Sensor 	CTS	2.39	Coolant temperature sensor SIG (I_A_CTS)
		2.59	Fuel temperature/coolant temperature sensor GND (G_R_AN18)
Crank Shaft Speed Sensor 	CRS	2.66	Crankshaft speed sensor POS (I_F_CRSPoS)
		2.65	Crankshaft speed sensor NEG (I_F_CRsNEG)
		2.69	Crankshaft/camshaft speed sensor protective GND (G_C_GND)
Cam Shaft Speed Sensor 	CAM	2.68	Camshaft speed sensor POS (I_F_CASPOS)
		2.67	Camshaft speed sensor NEG (I_F_CASNEG)
		2.69	Crankshaft/camshaft speed sensor protective GND (G_C_GND)

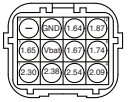
# 11. Electric system

Shape	Symbol	Pin No.	Circuit name
EGR Valve 	EGR	Vbat	24 V battery voltage (O_V_RH32)
		GND	Body GND
		2.18	CAN 2 LOW (B_D_CAN2L)
		2.17	CAN 2 HIGH (B_D_CAN2H)
Injector Connector 	INJ	2.49	Cylinder 1, injector 1 HIGH (O_P_SVH11)
		2.73	Cylinder 1, injector 1 LOW (O_P_SVL11)
		2.51	Cylinder 1, injector 3 HIGH (O_P_SVH13)
		2.75	Cylinder 1, injector 3 LOW (O_P_SVL13)
		2.50	Cylinder 1, injector 2 HIGH (O_P_SVH12)
		2.74	Cylinder 1, injector 2 LOW (O_P_SVL12)
		2.27	Cylinder 2, injector 3 HIGH (O_P_SVH23)
		2.03	Cylinder 2, injector 3 LOW (O_P_SVL23)
		2.25	Cylinder 2, injector 1 HIGH (O_P_SVH21)
		2.01	Cylinder 2, injector 1 LOW (O_P_SVL21)
		2.26	Cylinder 2, injector 2 HIGH (O_P_SVH22)
		2.02	Cylinder 2, injector 2 LOW (O_P_SVL22)
Fuel Temp Sensor 	FTS	2.12	Fuel temperature sensor SIG (I_A_FTS)
		2.59	Fuel temperature/coolant temperature sensor GND (G_R_AN18)
Inter Connector for Vehicle 	Interconnector (HFM, FAN clutch)	2.30	HFM sensor GND (G_R_AMS)
		2.38	HFM sensor temperature SIG (I_A_IATS)
		2.54	HFM sensor (I_A_IATS)
		2.09	HFM sensor PWR (V_V5VCAH)
		1.65	Fan speed sensor GND (G_R_FSS)
		Vbat	24 V Battery voltage
		1.67	Fan speed sensor PWR (O_V_5VSS2A)
		1.74	Fan actuator control SIG (O_V_RH21)
		GND	Body GND
		1.64	Fan speed sensor SIG (I_F_FSS)
		1.87	Fan actuator control SIG (O_T_FAN1)
Resistance 	Resistance	2.17	CAN 2 HIGH (B_D_CAN2H)
		2.18	CAN 2 LOW (B_D_CAN2L)

# 11. Electric system

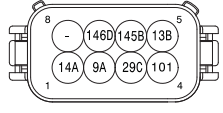
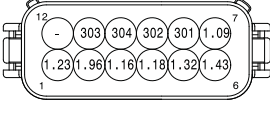
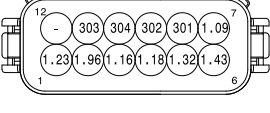
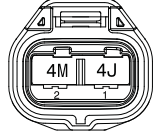
Shape	Symbol	Pin No.	Circuit name
<p>Fan Clutch</p> 	Fan	1.64	Fan Speed Sensor Output (FSS Out)
		1.65	Fan Speed Sensor Gnd
		1.67	Fan Speed Sensor Supply (U Sensor)
		1.74	Solenoid Coil High (Coil +)
		1.87	Solenoid Coil Low (Coil -)
<p>Inter Conn 1</p> 	INT 1	5	Start S
		1	Alternator R
		2	Alternator I
		3	Compressor +
<p>Inter Conn 2</p> 	INT 2	1	Dosing Valve High Side
		2	Dosing Valve Low Side
		3	DOC Upstream(T4) Signal
		4	DOC Upstream(T4) Ground
		5	SCR Upstream Signal
		6	SCR Upstream Ground
		7	SCR Downstream Signal
		8	Master NOX Sensor Ubatt
		9	Master NOX Sensor GND
		11	Master NOX Sensor CAN Low
10	Master NOX Sensor CAN High		
<p>Inter Conn for SCR</p> 	ICS	1	Dosing Valve High Side
		2	Dosing Valve Low Side
		3	DOC Upstream(T4) Signal
		4	DOC Upstream(T4) Ground
		5	SCR Upstream Signal
		6	SCR Upstream Ground
		7	SCR Downstream Signal
		8	Master NOX Sensor Ubatt
		9	Master NOX Sensor GND
		11	Master NOX Sensor CAN Low
10	Master NOX Sensor CAN High		
<p>Inter Conn 3</p> 	INT 3	1	Alternator B
		2	Alternator B

### **Boost pressure and temperature sensor**

1. The boost pressure and temperature sensor is connected to the intake manifold with the O-ring to measure the absolute pressure and temperature in the intake manifold.
2. Its output signal is sent to the ECU which then calculates the boost pressure based on the programmed characteristic curve.

### **Engine oil pressure and temperature sensor**

The engine oil pressure and temperature sensor detects the pressure and temperature of engine oil and sends these information to the ECU (Electronic Control Unit).

### **Engine coolant temperature sensor**

The engine coolant temperature sensor detects the temperature of engine coolant and sends this information to the ECU (Electronic Control Unit).

## 11. Electric system

### Common rail pressure sensor

Fuel passes through the passage in the common rail before it heads to the common rail pressure sensor.

The tip of this pressure sensor is sealed with the diaphragm. After fuel is pressurized, it reaches the diaphragm of the sensor through the hole.

A sensor to convert a fuel pressure value into an electric signal is connected to this diaphragm. This sensor produces a signal by amplifying the detected value before it delivers the signal to the ECU (Electronic Control Unit) and evaluation circuit.

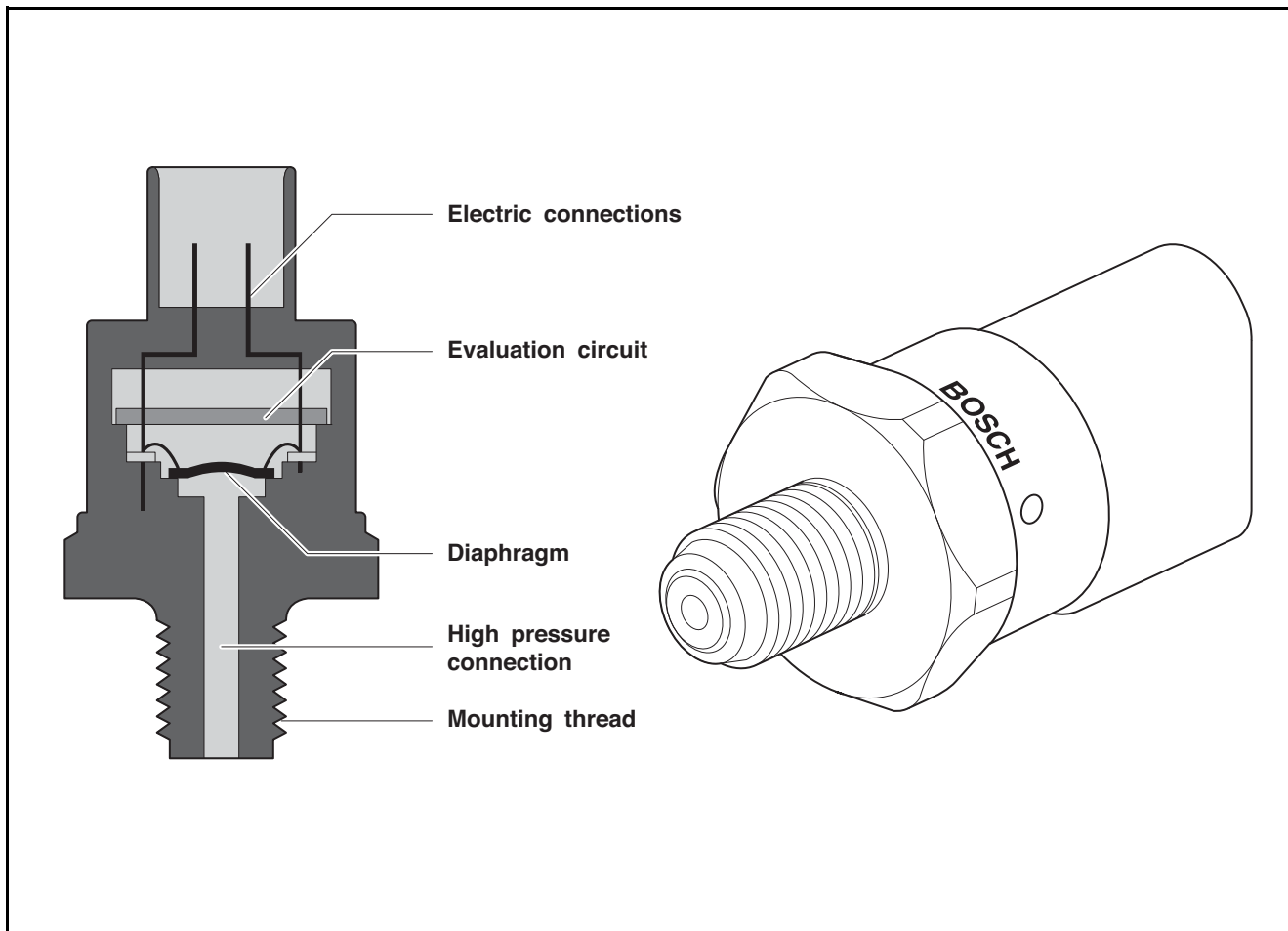

EE1OM099-E



### **Crankshaft speed sensor**

The position of the pistons in the combustion chamber has a major role in the fuel injection process.

All pistons in the engine are connected to the crankshaft by the connecting rod.

The flywheel housing is equipped with the crankshaft speed sensor to supply information for the position of all pistons.

This speed sensor detects the rotation per minute of the crankshaft, and this information is used by the ECU (Electronic Control Unit) for calculation as an important factor.

### **Camshaft speed sensor**

The camshaft speed sensor is used to control the intake and exhaust valves of the engine.

This rotates at half speed of the crankshaft. When the piston is moving toward T.D.C., it determines whether the camshaft position is in the compression stage or in the exhaust stage.

This information cannot be detected by the crankshaft speed sensor.

On the other hand, during normal operation, information supplied by the crankshaft speed sensor is enough to tell the condition of the engine.

In other words, if the camshaft speed sensor cannot detect the camshaft position while the engine is running, the ECU (Electronic Control Unit) receives engine condition information from the crankshaft speed sensor.

# 11. Electric system

## Pressure limiter valve

1. The pressure limiter valve is connected to the end of the common rail, and its body houses a conical plunger valve in it. This valve is normally closed by force of the spring at a normal operating pressure (1,800 bars) to keep the pressure in the common rail.
2. As soon as the pressure exceeds the operating pressure limit, load is applied to the spring of the valve to keep the fuel pressure at a normal level. After fuel passes through the valve, it is returned to the fuel tank through the return pipe.

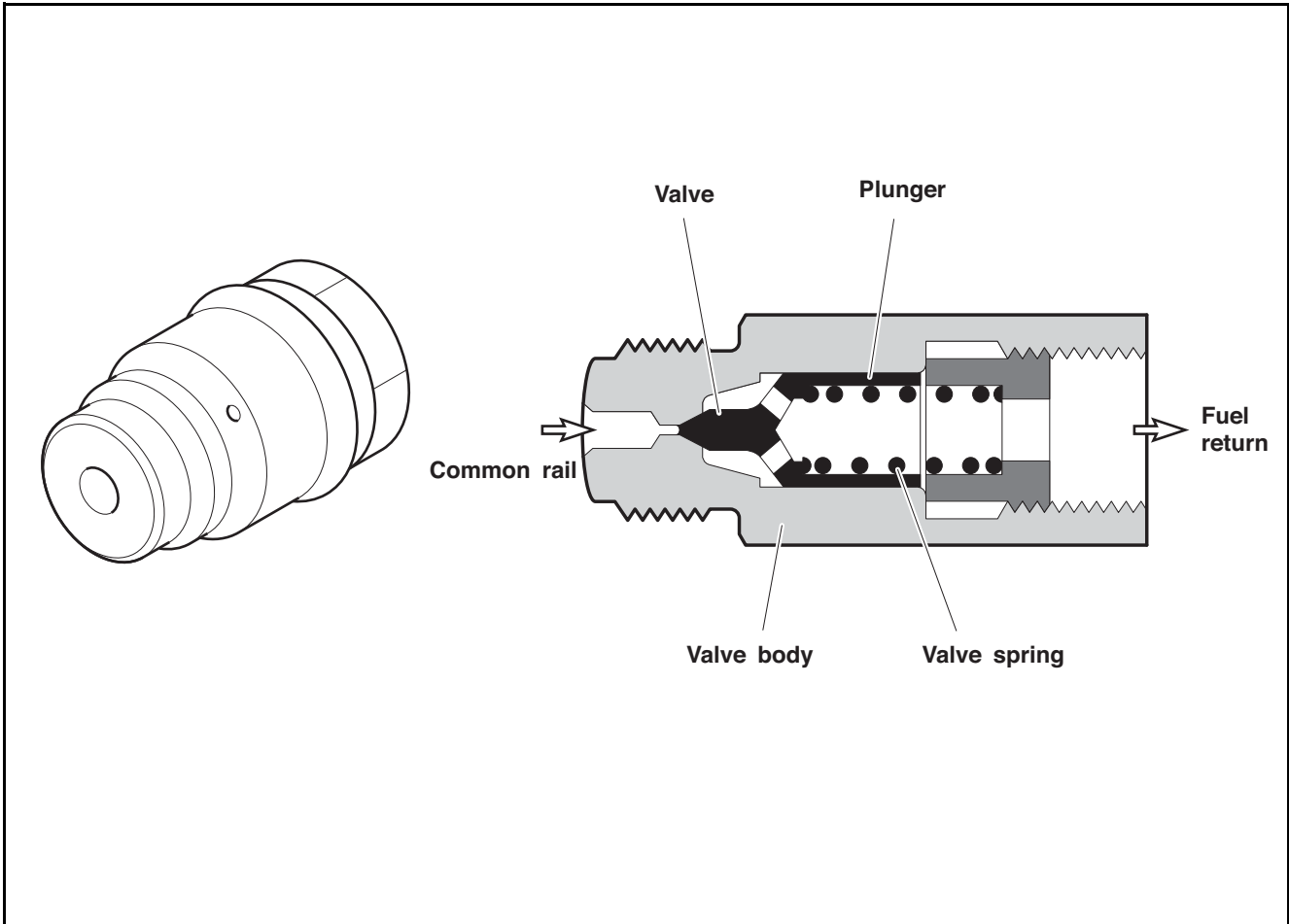

EE10M100-E

## Accelerator pedal sensor

When a driver depresses the accelerator pedal, the accelerator pedal sensor senses this and delivers this information to the ECU (Electronic Control Unit).

As the voltage value is produced by the potentiometer in the accelerator pedal sensor, this is used to calculate the position of the pedal based on the programmed characteristic curve.

## ECU (Electronic Control Unit)

### ECU (Engine Control Unit) connector

There are two ECU (Engine Control Unit) connectors: one for connection to the vehicle and one for connection to the engine.

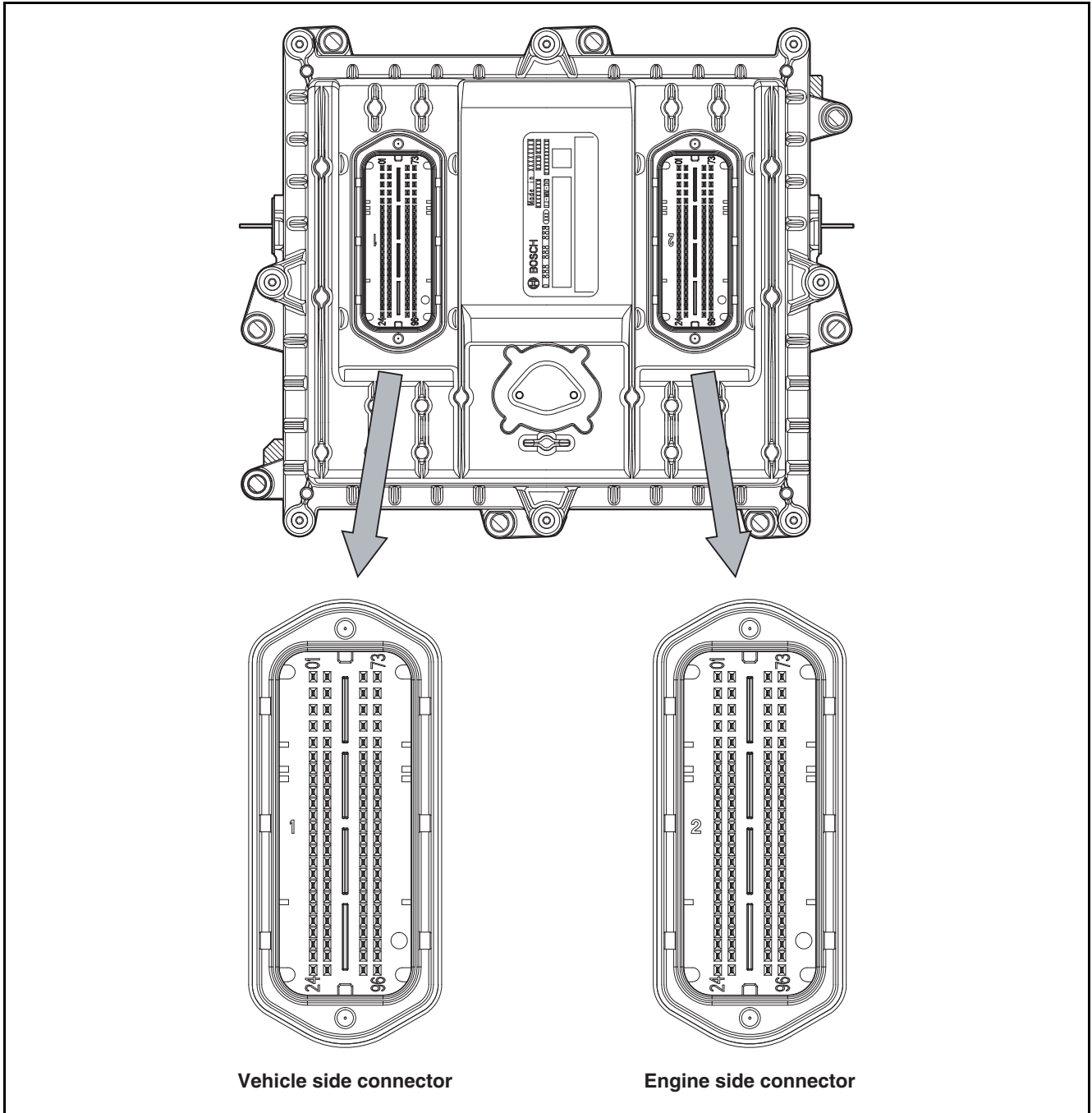

EDL0620004

# 11. Electric system

## ECU (Engine Control Unit) input/output

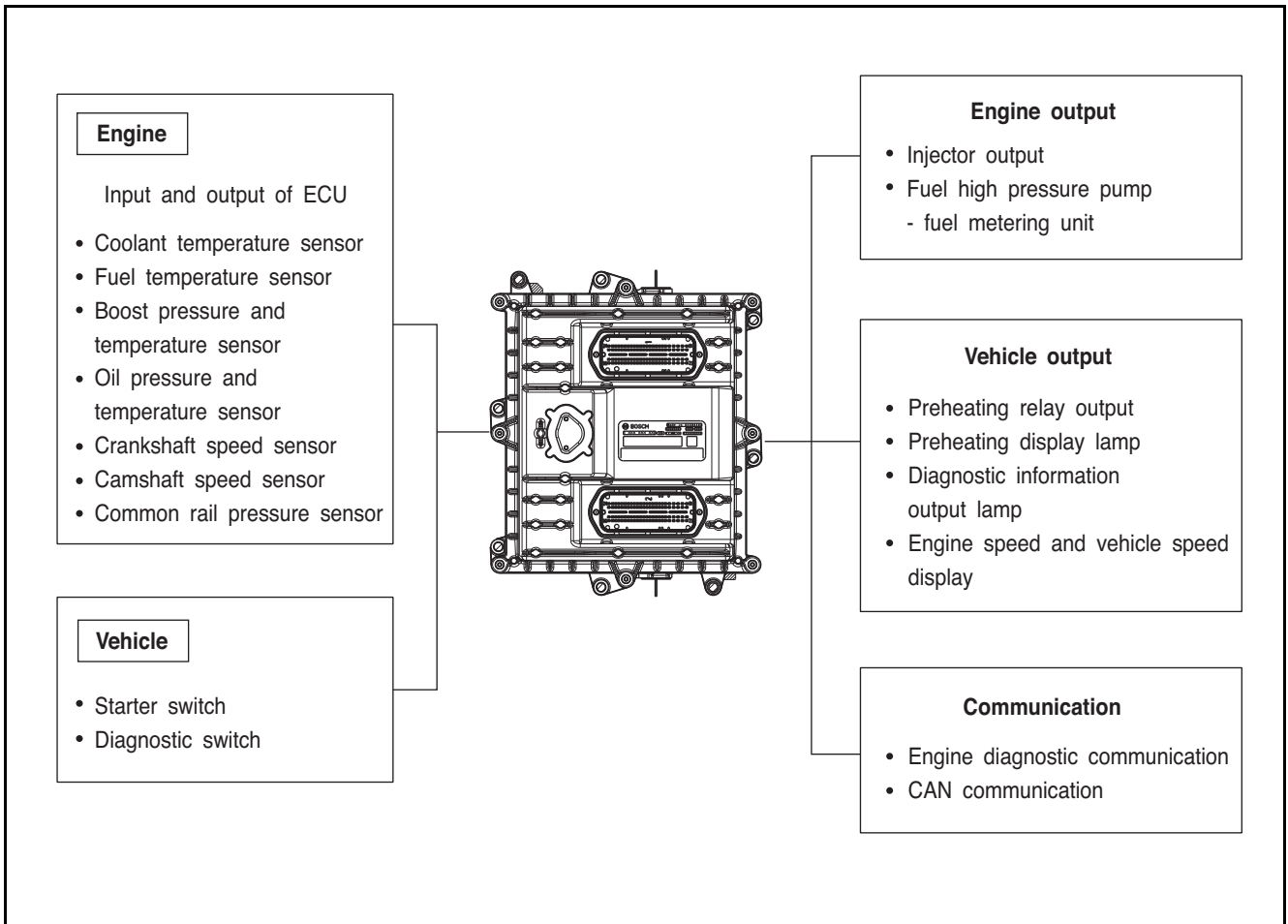

EK1OM067

## Operational conditions of Electronic Control Unit (ECU)

1. Engine Start
  - 1) Sets the reference temperature for determining preheat to the lowest temperature among coolant temperature, fuel temperature, intake air temperature, and oil temperature.
  - 2) Sets the reference temperature for determining fuel volume by setting the engine cooling temperature.
  - 3) Determines the appropriate fuel volume to start the engine, delivers the fuel to the engine, and measures the RPM signal by using the crankshaft rev-count sensor.
2. Vehicle driving
  - 1) Calculates the required data for driving a vehicle, such as CAN data and the RPM transferred from the vehicle control unit.
3. Driver-requested Adjustment of RPM
  - 1) Controls the RPM based on request from the driver and controls the engine based on the RPM requested by the vehicle control unit.
4. Limp Home
  - 1) A function that allows drivers to drive their vehicle to the repair center safely with the minimum conditions for driving the vehicle when a fault code occurs.
  - 2) Limp Home function is applied under the following conditions.
    - Accelerator pedal has failed: Regardless of pressing the accelerator pedal, the vehicle is driven at a consistent RPM.
    - Sensor has failed: When sensors have failed, the vehicle is driven with the consistent alternative values.
    - Output is limited: According to the fault type, the fuel volume delivered to the engine is limited. The limit is classified into four levels. The fuel volume is limited according to the severity of the fault.
    - Diagnosis Information Display Lamp: Provides information of fault state to drivers for safe driving.
5. Failure Diagnosis
  - 1) When a fault occurs, the failure diagnosis information display lamp on the gauge board is turned on.
  - 2) With the failure diagnosis information display lamp, drivers can see the fault code.

Note) It can be checked from the failure diagnosis information on the gauge board.

  - 3) It can be diagnosed by connecting the diagnosis unit to the check connector at the back of the driver's seat.
6. Driving record
  - 1) Writes the information related driving to the ECU.
  - 2) The information on fuel consumption, engine use time, and ECU use time is written in the ECU.

- 3) The information can be monitored with the ECU diagnosis device.

# 11. Electric system

---

## Starter

### General information

The start motor is installed behind the flywheel housing.  
When disassembling the engine, soak the start motor's pinion gear and ring gear into fuel and clean them with a brush thoroughly. Then, apply grease to them prevent their corrosion.

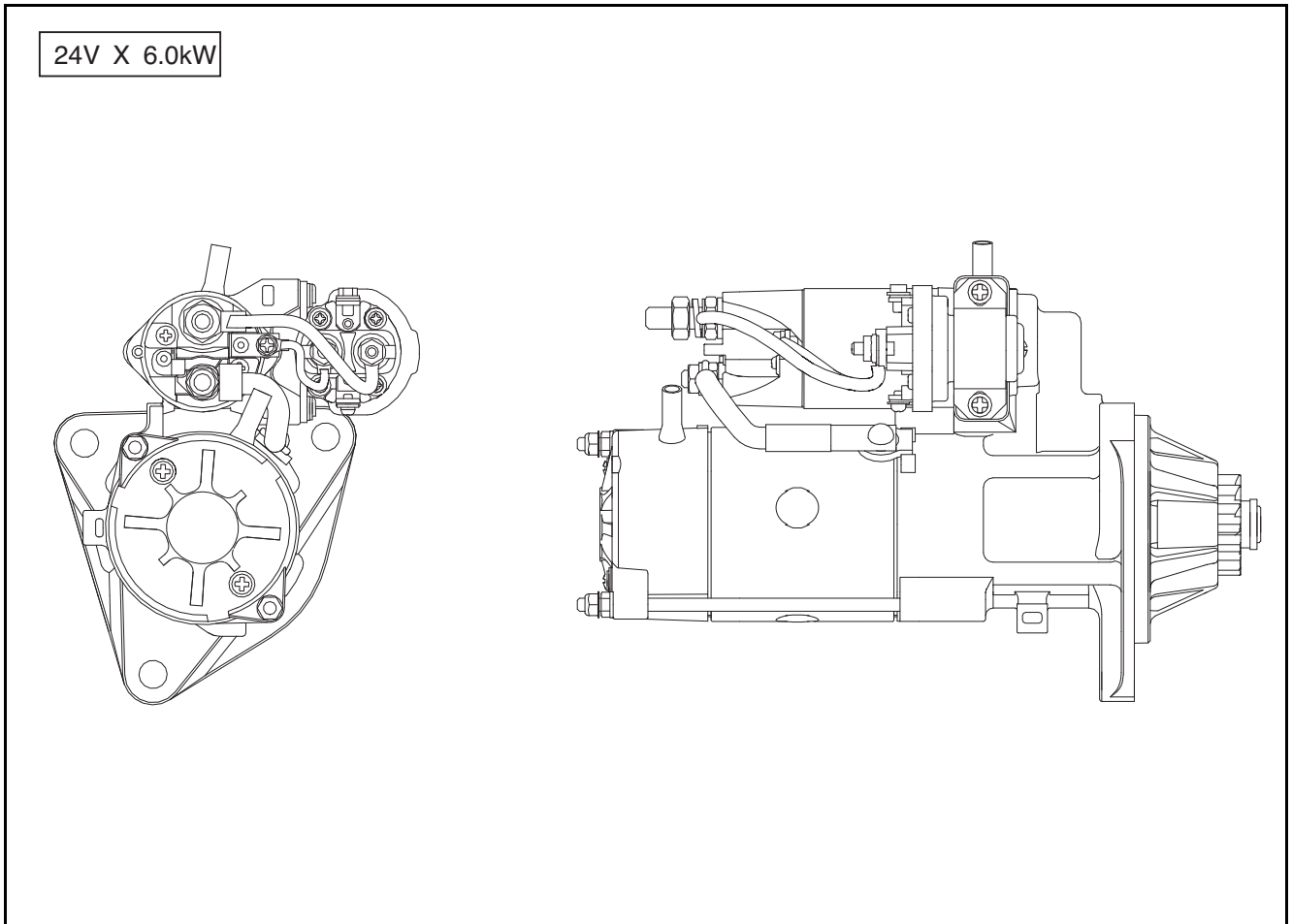

EK4OM010

---

### CAUTION

The start motor should always be protected from moisture and humid condition.

---

## Circuit diagram

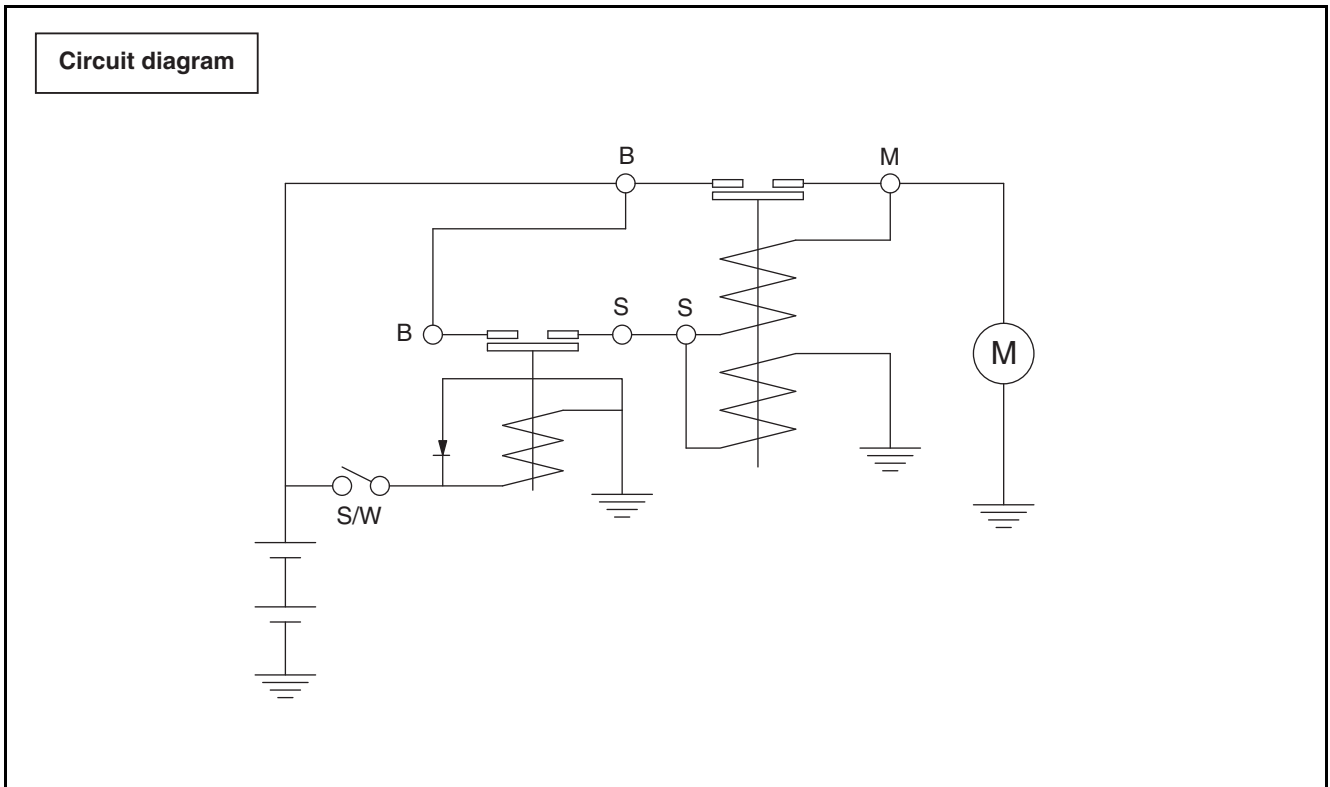

EDL06180022

### **⚠ CAUTION**

**Before working on any electric system, make sure to disconnect the negative battery cable in advance. Connect the ground cable last after work to avoid a short circuit during work.**

# 11. Electric system

## Exhaust gas reduction

### General information

1. Connector
- 1) Mark by connector part

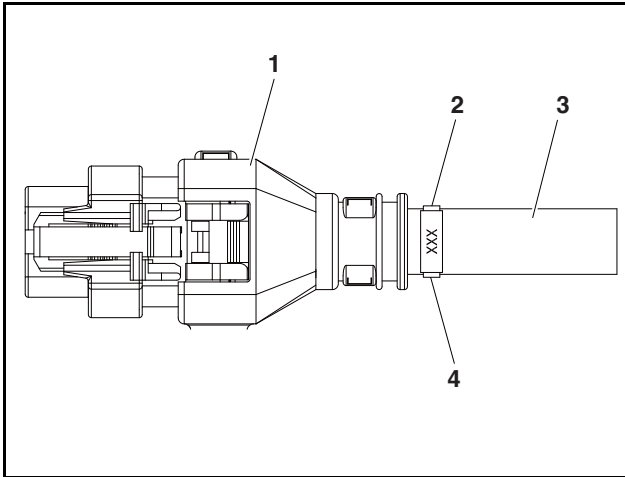

EK00315A

1. Wire cover
2. Cable tie
3. C/Tube
4. Tube (white)

- 2) If the connector has no cover, wrap the end of the connector with plastic tape.

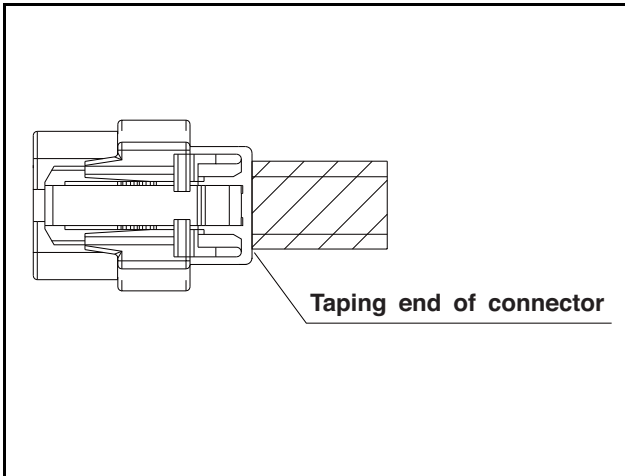

EK00316A

2. Tolerance for allowable wiring distance
  - 1) Between fixed points: +5 mm
  - 2) Between fixed points before junction: +5 mm
  - 3) Connector end or fixed point or junction of terminal type: +10 mm
- Note) End of injector junction: +5 mm
3. Symbol

	Symbol	Description
1		Apply aluminum tape
2		Apply manifold
3		Apply cross taping
4		Apply heat resisting transparent tape (125° or higher)
5		Apply corrugate tube



## Circuit diagram

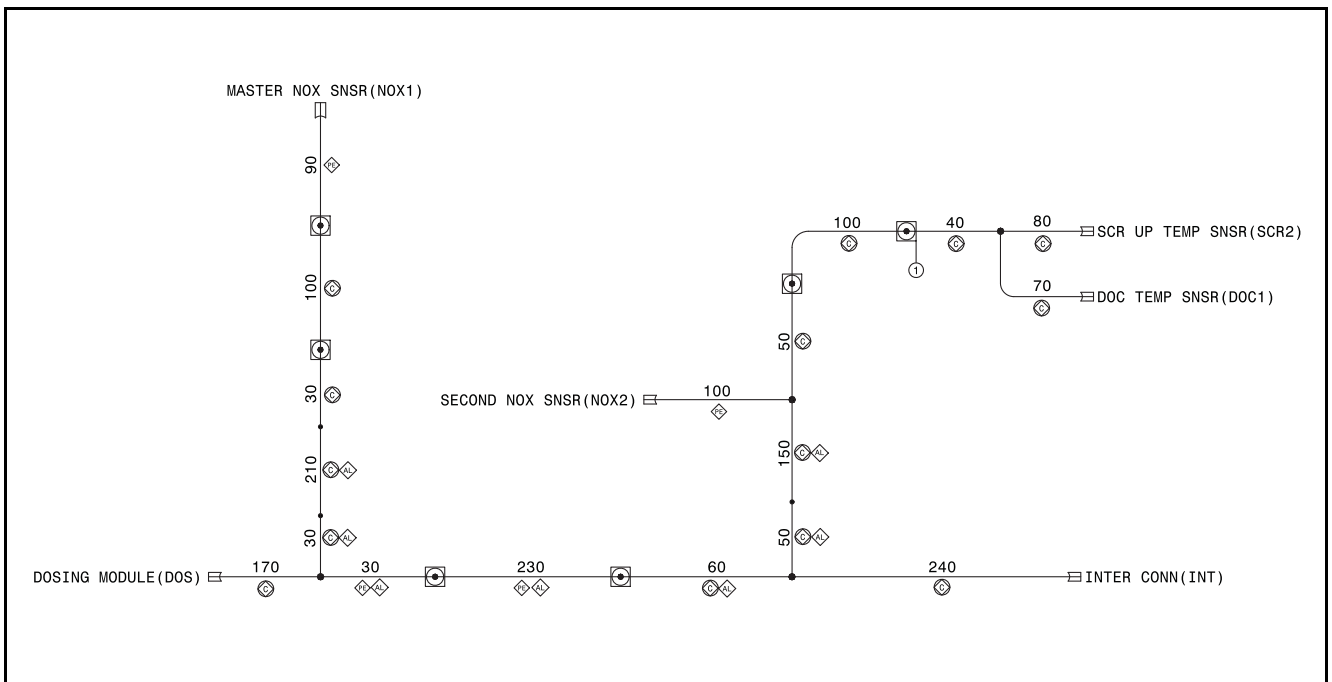

EDL06180031

# 11. Electric system

## Aftertreatment connector

No.	Wire Label	Wire Kind	Size (mm <sup>2</sup> )	Color	Circuit Description	From	No.	To	No.	Remark
1	1.23	FLR7Y-A SN	1.50	W	Dosing Valve High Side	Dosing Module (DOS)	1	Injector Connector (INT)	1	Twist Pair (1.23/1.96)
2	1.96	FLR7Y-A SN	1.50	B	Dosing Valve Low Side	Dosing Module (DOS)	2	Injector Connector (INT)	2	Twist Pair (1.23/1.96)
3	1.16	FLR7Y-A SN	0.75	W	DOC Upstream(T4) Signal	DOC Temp SNSR (DOC1)	1	Injector Connector (INT)	3	
4	1.18	FLR7Y-A SN	0.75	B	DOC Upstream(T4) Ground	DOC Temp SNSR (DOC1)	2	Injector Connector (INT)	4	
5	1.32	FLR7Y-A SN	0.75	W	SCR Upstream Signal	SCR Up Temp SNSR (SCR2)	1	Injector Connector (INT)	5	
6	1.43	FLR7Y-A SN	0.75	B	SCR Upstream Ground	SCR Up Temp SNSR (SCR2)	2	Injector Connector (INT)	6	
7	301	FLR7Y-A SN	0.75	W	Master NOX Sensor Ubatt	Master NOX SNSR (NOX1)	1	Injector Connector (INT)	8	
8	302	FLR7Y-A SN	0.75	B	Master NOX Sensor GND	Master NOX SNSR (NOX1)	4	Injector Connector (INT)	9	
9	303	FLR7YB33X SN	0.75	O	Master NOX Sensor CAN Low	Master NOX SNSR (NOX 1)	2	Injector Connector (INT)	11	Shield 303/304
10	304	FLR7YB33X SN	0.75	W	Master NOX Sensor CAN High	Master NOX SNSR (NOX 1)	3	Injector Connector (INT)	10	Shield 303/304
11	305	FLR7Y-A SN	0.75	W	Secondary NOX Sensor Ubatt	Second NOX SNSR (NOX 2)	1	301		Splice_301
12	306	FLR7Y-A SN	0.75	B	Secondary NOX Sensor GND	Second NOX SNSR (NOX 2)	4	302		Splice_302
13	307	FLR7YB33X SN	0.75	O	Secondary NOX Sensor CAN Low	Second NOX SNSR (NOX 2)	2	303		Splice_303, Shield 307/308
14	308	FLR7YB33X SN	0.75	W	Secondary NOX Sensor CAN High	Second NOX SNSR (NOX 2)	3	304		Splice_304, Shield 307/308

## Switches and sensors

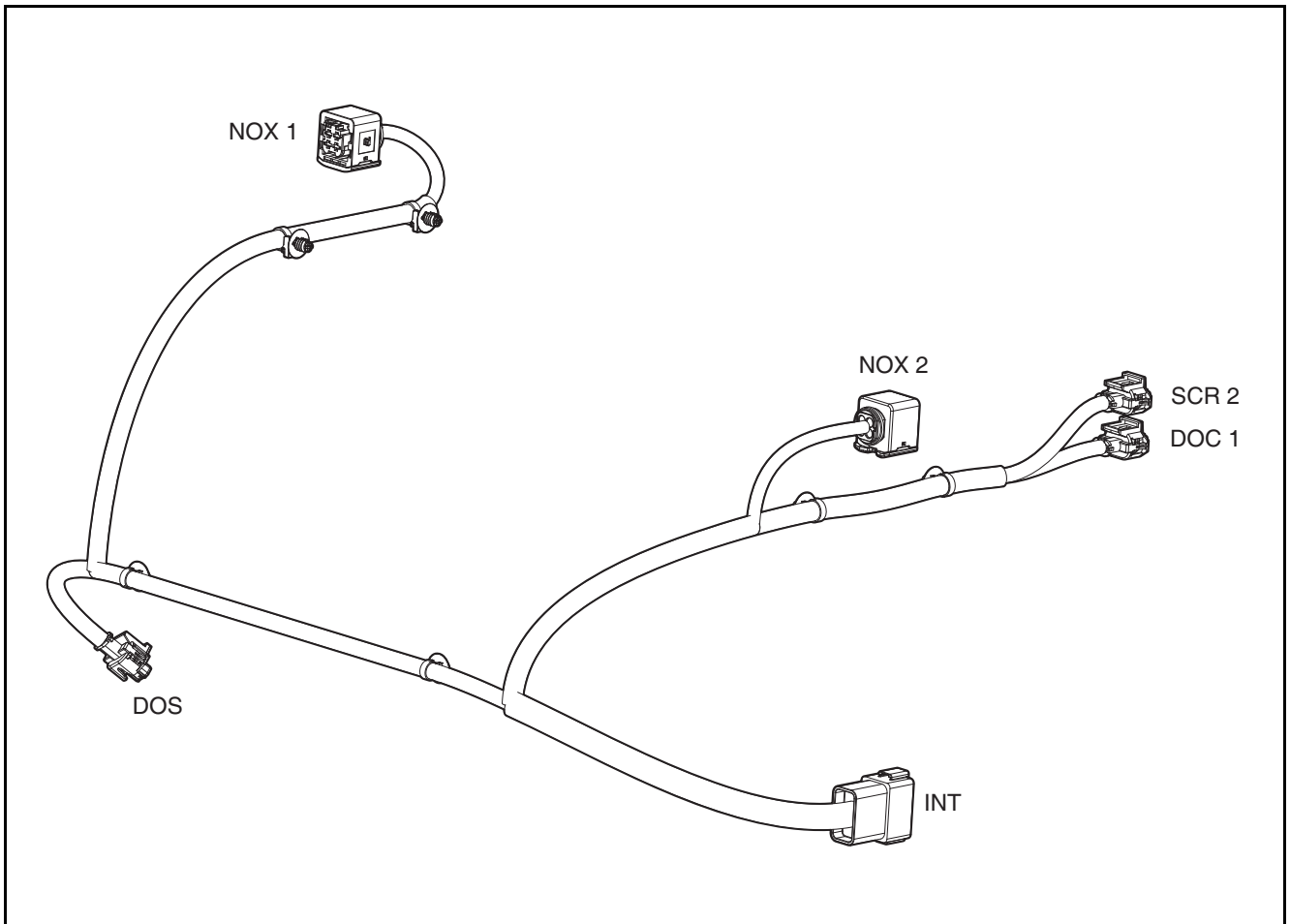

EDL06200009

1. Dosing module (DOS)

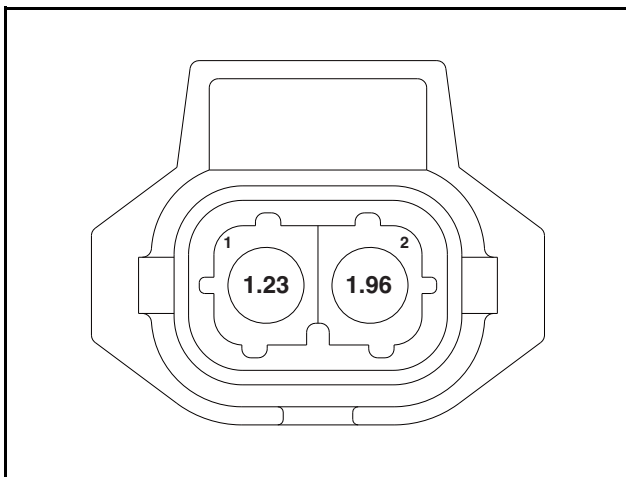

EK00319A

2. Master NOX sensor (NOX1)

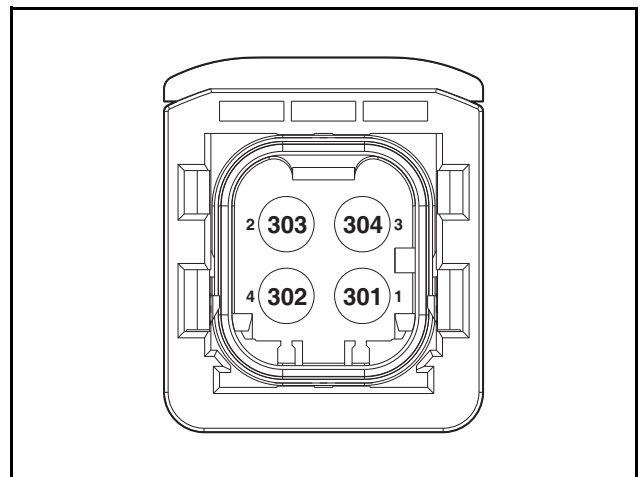

EDL06200010

# 11. Electric system

3. Secondary NOX sensor (NOX2)

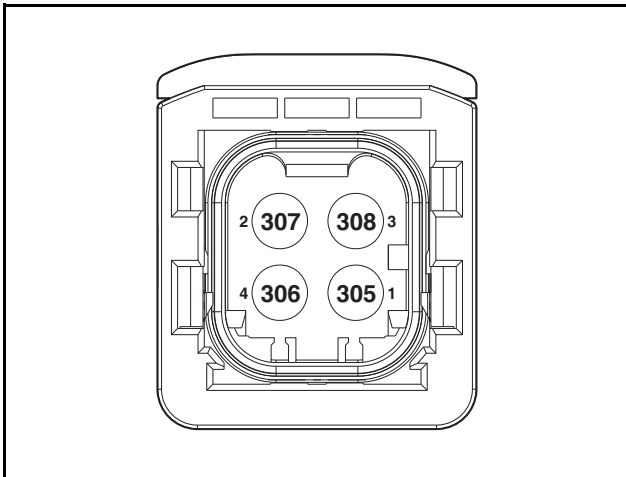

EDL06200011

6. Inter connector (INT)

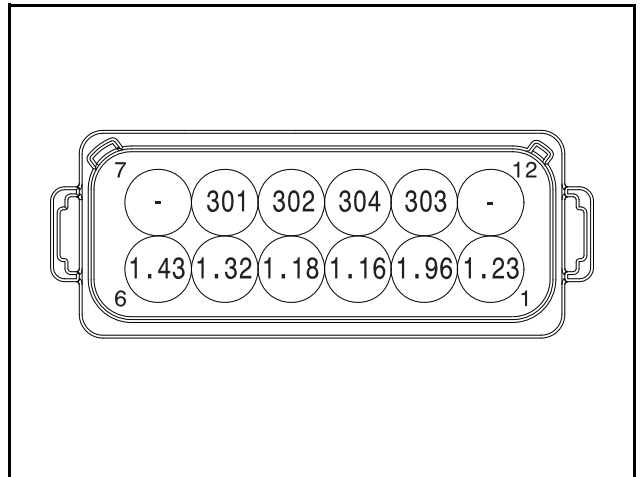

EDL06180033

4. SCR upstream temperature sensor (SCR2)

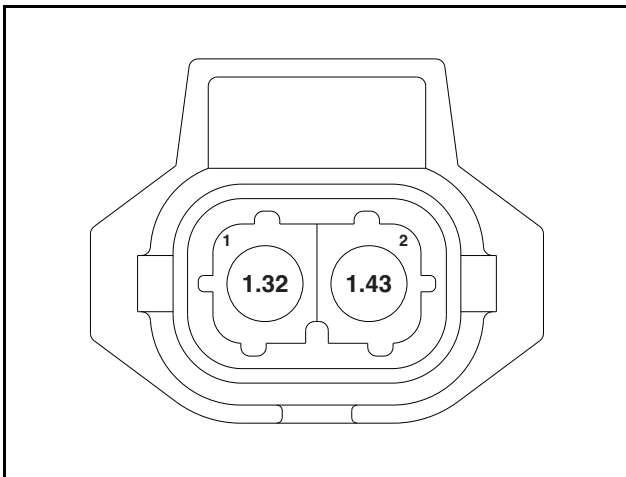

EK00323A

5. DOC temperature sensor (DOC1)

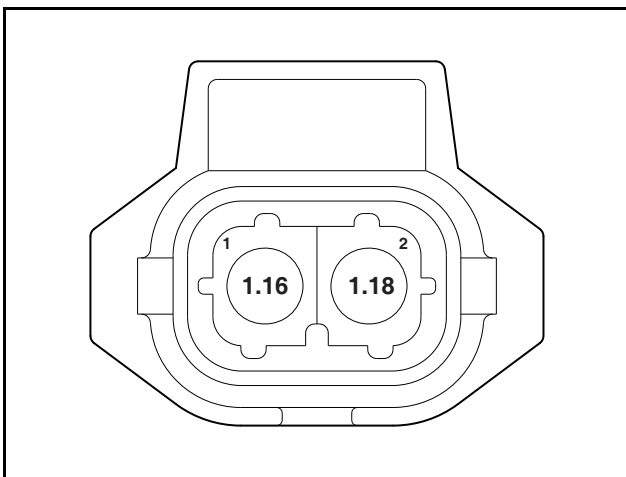

EDL06200012

# 12. Others/Driving system

General information .....	215
General information .....	215
Crankshaft .....	216
Crankshaft inspection .....	216
Crankshaft bearing and connecting rod inspection .....	217
Piston .....	220
Piston disassembly .....	220
Piston assembly .....	220
Piston inspection .....	220
Piston ring inspection .....	220
Piston and piston pin inspection .....	221
Connecting rod .....	222
Connecting rod inspection .....	222
Others .....	223
Engine timing .....	223



### General information

#### General information

1. This engine cools the pistons through the oil gallery. To obtain optimum cooling efficiency from the gallery, the nozzle shape, nozzle position and oil flow play important roles. The piston gallery is designed to facilitate oil flow efficiency in order to obtain superior cooling efficiency.
2. The crankshaft is a single unit. The crankshaft and rear oil seal prevent oil from getting into the flywheel housing.
3. The connecting rod is a single unit as well. As its big end can be separated horizontally, it can be removed through the top of the cylinder with the piston. An alloy bearing assembly is used on the operating part of the crankshaft and connecting rod.
4. The camshaft, oil pump and fuel high-pressure pump are driven by the gear connection in the flywheel housing.
5. The overhead valve is operated through the valve tappet, push rod and rocker arm from the camshaft.

## 12. Others/Driving system

### Crankshaft

#### Crankshaft inspection

1. Inspection for defect
  - 1) Visually check the crankshaft journal and crank pin for a scratch or crack.
  - 2) Perform the magnetic particle test or dye penetrant test (color check) to check the crankshaft for a crack. If the crankshaft is cracked, replace it.
2. Wear measurement
  - 1) Use a O.D. micrometer to measure the journal and pin of the crankshaft in the specified direction as illustrated to check its wear amount.

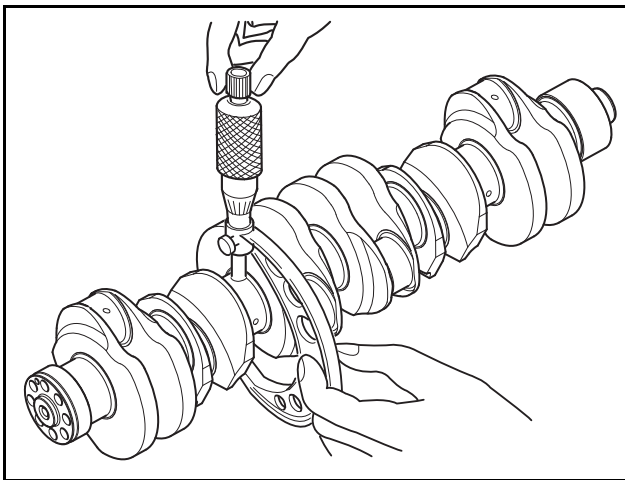

EH6OM026

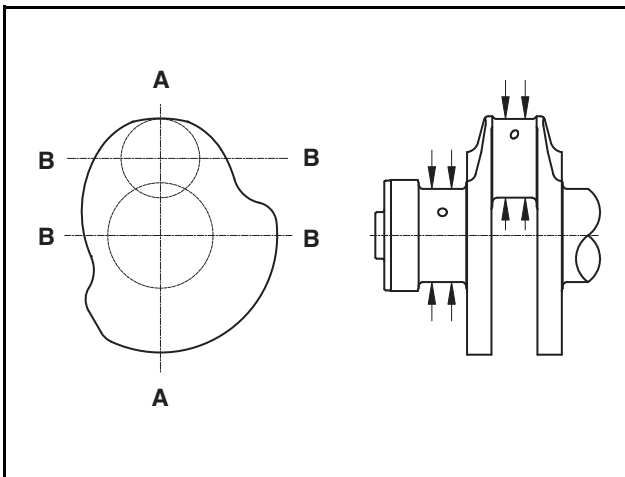

EH6OM033

- 2) If the wear amount is over the allowable limit, grind the crankshaft to install an undersized bearing.
  - 3) However, if the wear amount is within the allowable limit, correct it with an oily whetstone or fine oily sandpaper.
- Note) Use a sandpaper soaked in oil.

	Standard	Allowable limit
Journal O.D.	Ø79.905 - Ø79.925 mm	Ø79.405 mm
Pin O.D.	Ø68.924 - Ø68.944 mm	Ø68.424 mm

- 4) If the pin wear amount is over the allowable limit, grind the crank journal and crank pin and use an undersized bearing.

Note) Use a sandpaper soaked in oil to grind the crankshaft.

- 5) There are two types of undersized bearings. The crankshaft can be reused by grinding it according to the undersized bearing to be used.

- Standard
  - 0.25 (I.D.: 0.25 mm smaller than standard)
  - 0.50 (I.D.: 0.50 mm smaller than standard)
- 6) Standard for section "R"
    - Crank pin section "R": 3.3 - 3.7
    - Crank journal section "R": 3.3 - 3.7

### CAUTION

When grinding the crankshaft, the section "R" at the end of the bearing should be precisely ground. There should be no step or rough surface.

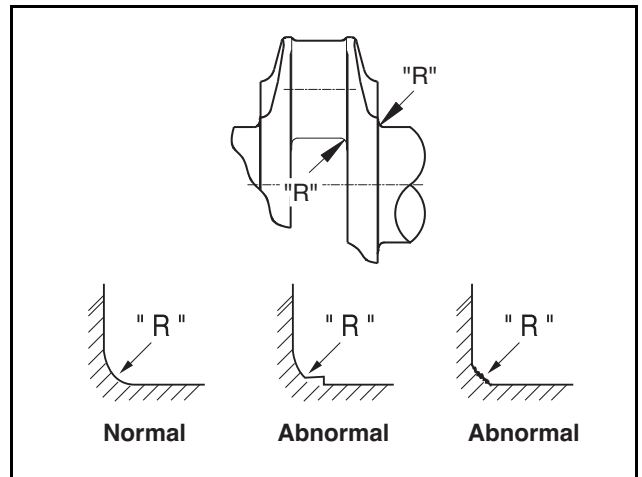

EH6OM034

3. Crankshaft deflection

- 1) Place the crankshaft on two V-blocks.
- 2) Place a dial gauge on the surface plate. While turning the crankshaft, measure the deflection of the crankshaft.

Standard	Allowable limit
0.06 mm	0.15 mm or below



## 12. Others/Driving system

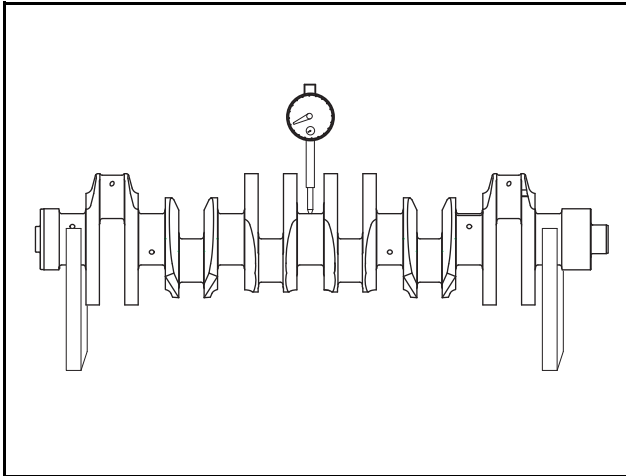

EH6OM035

### Crankshaft bearing and connecting rod inspection

1. Visual inspection
  - 1) Visually check the crankshaft bearing and connecting rod bearing for a scratch, abnormal wear or damage.
2. Oil clearance between crankshaft and bearing (method 1: using dial gauge):
  - 1) Main bearing clearance
    - a) Install the main bearing to the cylinder block, tighten the bearing cap to the specified torque, and measure the inside diameter.

Torque	6 kg·m + 90°
--------	--------------

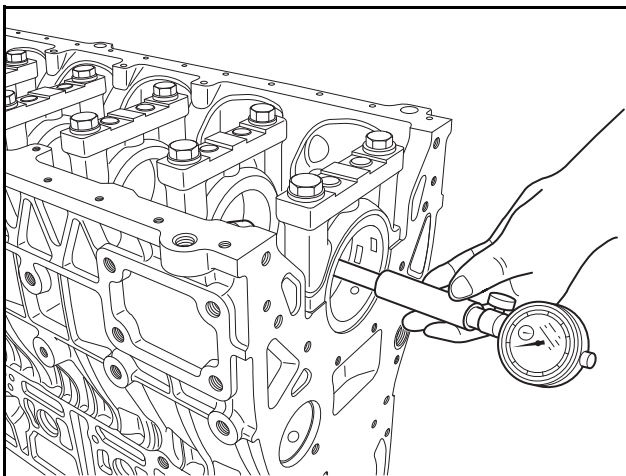

EH6OM036

- b) Compare the inside diameter of the main bearing with the outside diameter of the crankshaft journal to calculate the oil clearance.

Main bearing oil clearance	
Standard	Allowable limit
0.045 - 0.110 mm	0.15 mm

#### 2) Connecting rod bearing clearance

- a) Install the connecting rod bearing to the connecting rod bearing cap, tighten the bolt to the specified torque, and measure the inside diameter.

Torque	1 step	3 ±0.15 kg·m
	2 step	60 ±3°

### **⚠ CAUTION**

When tightening the connecting rod bolt, tighten it with a hand until its head touches the bolt seat of the connecting rod. Then, tighten it finally with a torque wrench.

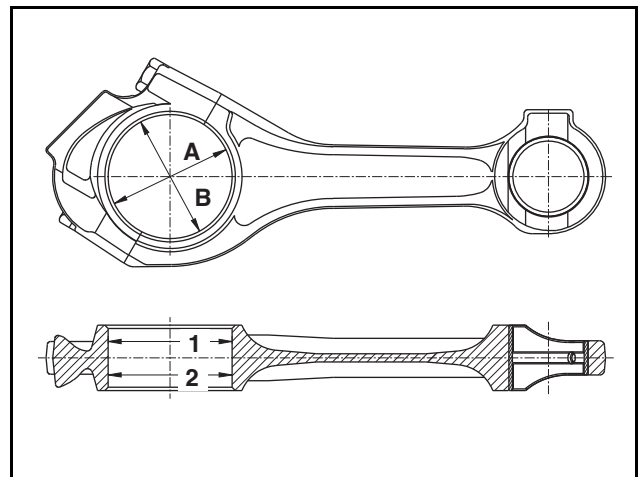

EH6OM037

- b) Compare the two values obtained from measurement of the inside diameter of the connecting rod bearing with the outside diameter of the crankshaft pin to calculate the oil clearance.

Standard	Allowable limit
0.030 - 0.081 mm	0.15 mm

## 12. Others/Driving system

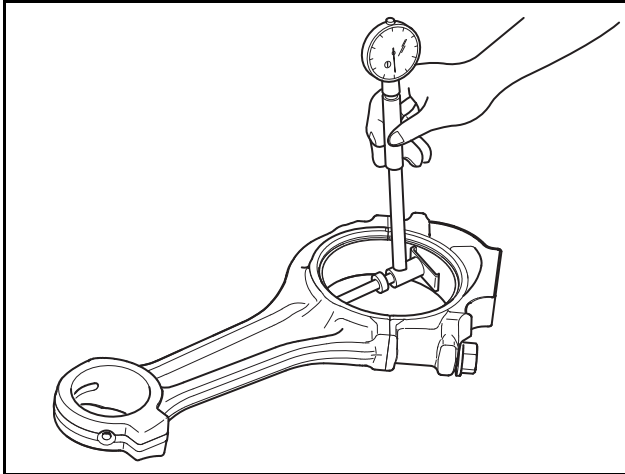

EH6OM038

- c) If the clearance is over the allowable limit, grind the crankshaft journal and pin sections to install an under-sized bearing.
3. Oil clearance between crankshaft and bearing (method 2: using plastigauge):
  - 1) Install the crankshaft onto the cylinder block.
  - 2) Place a plastigauge onto the journal and pin sections of the crankshaft.
  - 3) Install the bearing cap and tighten the bolt to the specified torque.
  - 4) Unscrew the bolt to remove the bearing cap.
  - 5) Measure the thickness of the flat section of the plastigauge with a plastigauge measuring ruler.
  - 6) This is the oil clearance.
4. Bearing spread and crush
  - 1) Inspection
    - a) When installing the bearing, check if a large crush is felt.

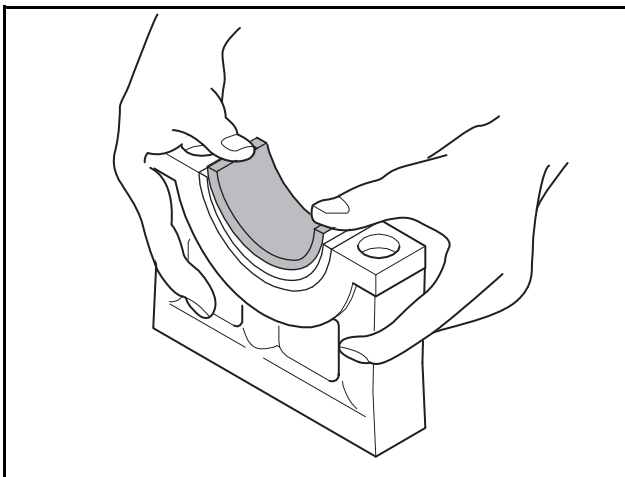

EH6OM039

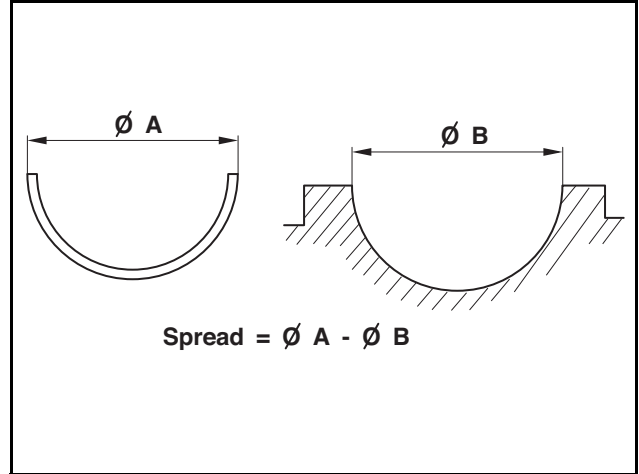

EDM20471-E

- 2) Bearing cap crush
  - a) Install the bearing and cap to the cylinder block.
  - b) Tighten the bolt to the specified tightening torque.
  - c) Unscrew one bolt completely and use a feeler gauge to measure the clearance between the bearing cap and cylinder block.

Standard	0.065 - 0.105 mm
----------	------------------

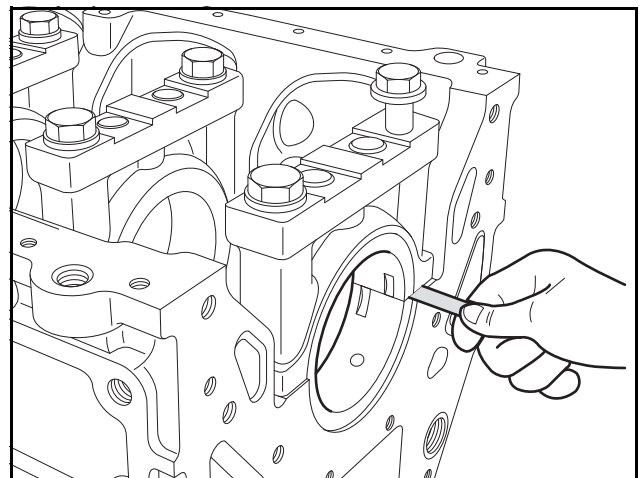

EH6OM040

- 3) Connecting rod bearing crush
  - a) Install the bearing and cap to the big end of the connecting rod.
  - b) Tighten the bolt to the specified tightening torque.
  - c) Unscrew one bolt completely and use a feeler gauge to measure the clearance between the bearing cap and connecting rod big end.

Standard	0.085 - 0.125 mm
----------	------------------

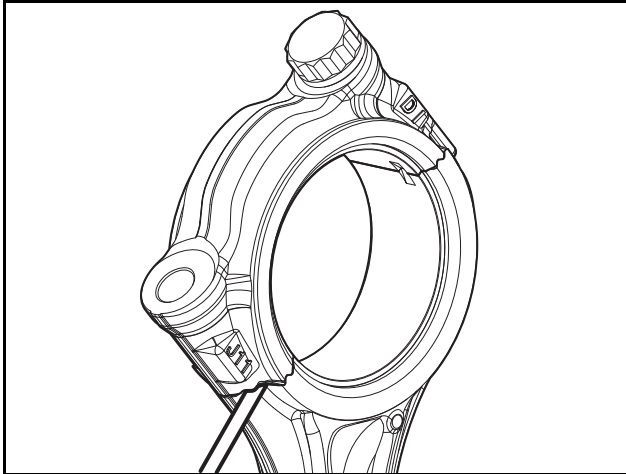

EDL06200019

#### 4) Axial play of crankshaft

- a) Install the crankshaft onto the cylinder block.
- b) Use a dial gauge to measure the axial play of the crankshaft.

Standard	Allowable limit
0.14 - 0.33 mm	0.4 mm

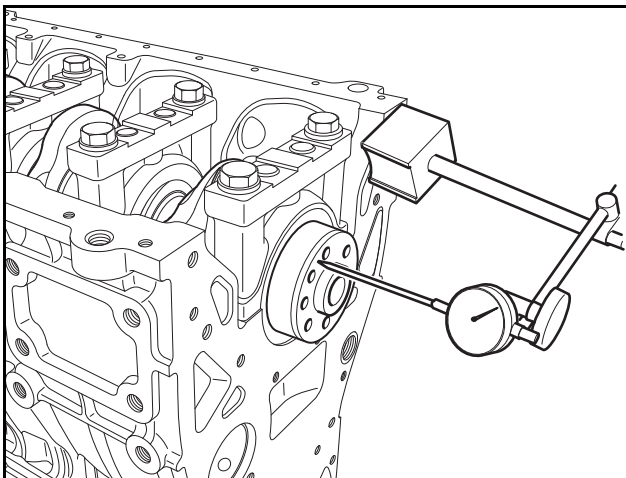

EH6OM041

## 12. Others/Driving system

### Piston

#### Piston disassembly

1. Disassemble the piston according to the specified disassembly steps.

#### Piston assembly

1. Assemble the piston according to the specified assembly steps.

#### Piston inspection

1. Visual inspection
  - 1) Visually inspect the piston for a crack, scratch and wear.
  - 2) Especially, check if the ring groove is worn.
2. Clearance between piston and cylinder liner
  - 1) Use an O.D. micrometer to measure the outside diameter of the piston at the position 12 mm down from the bottom of the piston in the orthogonal direction of the piston pin hole.

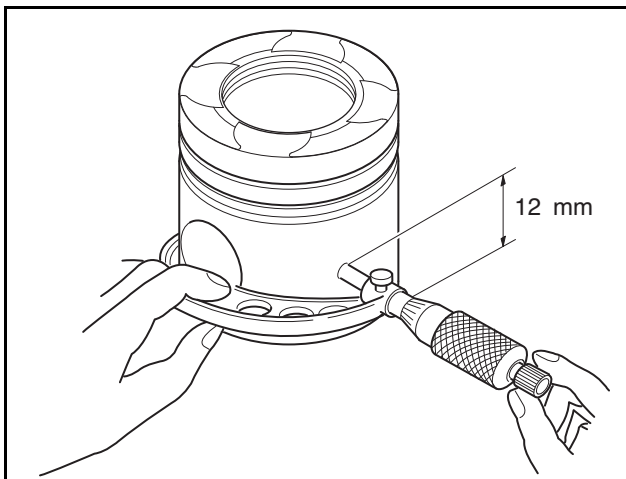

EH6OM042

- 2) Use a cylinder I.D. gauge to measure the inside diameter of the cylinder liner.

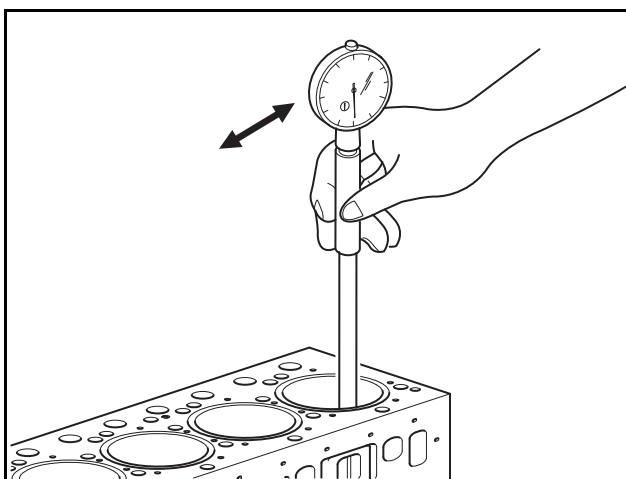

EH6OM043

- 3) Perform the measurement at 3 locations of the cylinder liner: the top ring contact section, middle section, and oil ring contact section around the B.D.C. in the 45° direction.
- 4) Calculate the average value from the measurement results and exclude the maximum and minimum values.
- 5) The clearance can be calculated by subtracting the outside diameter of the piston from the inside diameter of the cylinder liner.
- 6) If this value is over the allowable limit, replace either the piston or cylinder liner which is worn more.

Clearance between piston and liner	
Standard	0.079 - 0.101 mm

#### Piston ring inspection

1. Visual inspection
  - 1) If any worn or damaged piston ring is found during disassembling the engine, replace it with a new one.
2. Piston ring gap
  - 1) Insert the piston into the top of the cylinder at a right angle to the cylinder liner wall.
  - 2) Use a feeler gauge to measure the piston ring gap.

	Standard	Allowable limit
Ring No. 1	0.25 - 0.35 mm	1.5 mm
Ring No. 2	0.80 - 1.00 mm	1.5 mm
Oil ring	0.25 - 0.45 mm	1.5 mm

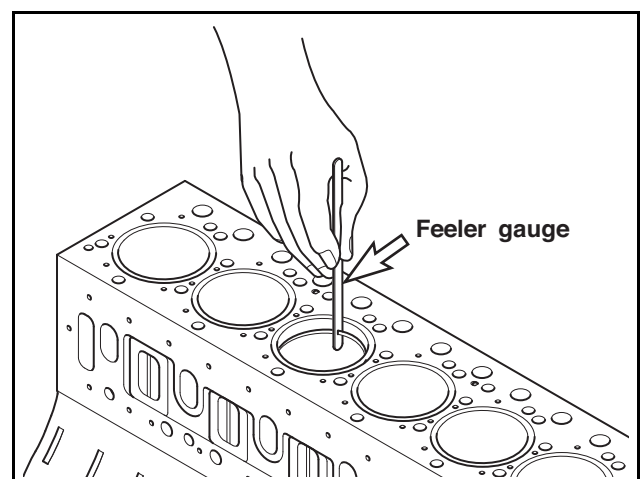

EH6OM044-E

- 3) If the piston ring gap is over the allowable limit, replace the piston ring with a new one.
3. Piston ring side clearance
    - 1) Install the compression ring and oil ring to the piston's ring groove.

## 12. Others/Driving system

- 2) Use a feeler gauge to measure the side clearance of the ring.

	Standard	Allowable limit
Ring No. 1	-	-
Ring No. 2	0.05 - 0.09 mm	0.15 mm
Oil ring	0.03 - 0.07 mm	0.15 mm

- 3) If the measurement is over the allowable limit, replace the ring or piston.

### 4. Piston ring tension

- 1) Use a tension gauge to measure the tension of the piston ring.  
2) If the measurement is over the allowable limit, replace the piston ring.

	Standard
Ring No. 1	18 ±3.6 N
Ring No. 2	17.7 ±3.5 N
Oil ring	4.8 ±0.72 kg

### Piston and piston pin inspection

1. Measure the wear amount of the piston pin.

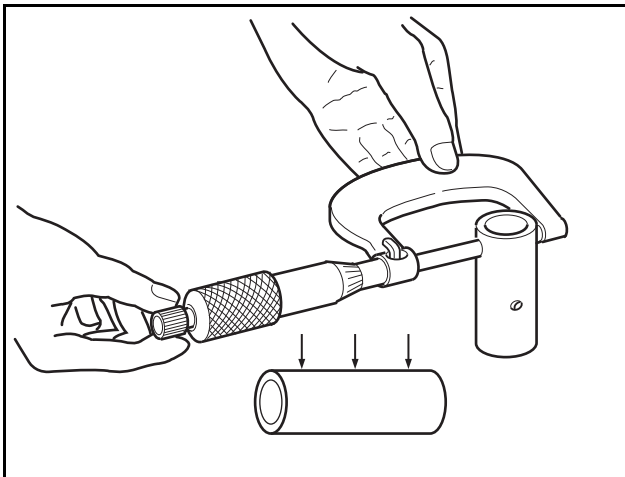

EA0M4031

2. If the measurement is over the allowable limit, replace the pin.

Standard value for piston pin	Allowable limit
Ø39.994 - Ø40.000 mm	Ø39.914 mm

3. Measure the clearance between the piston pin and connecting rod bushing.

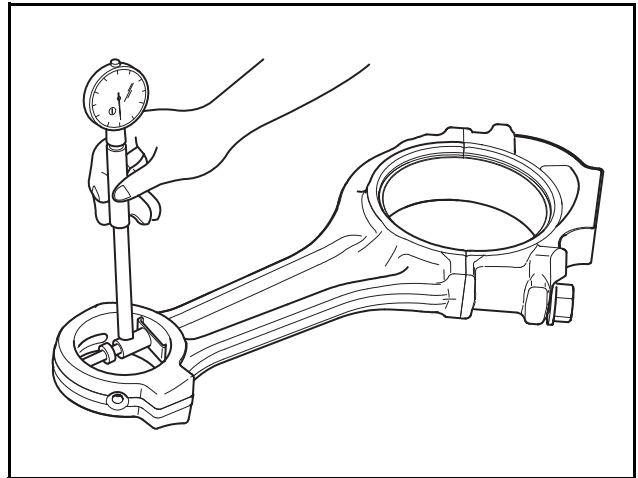

EH6OM067

4. If the measurement is over the allowable limit, replace either one of them which is worn more.

Standard	Allowable limit
0.040 - 0.056 mm	0.08 mm

5. Check the mounting status of the piston and piston pin.

### **⚠ CAUTION**

If the piston needs to be replaced, replace the piston pin as well.

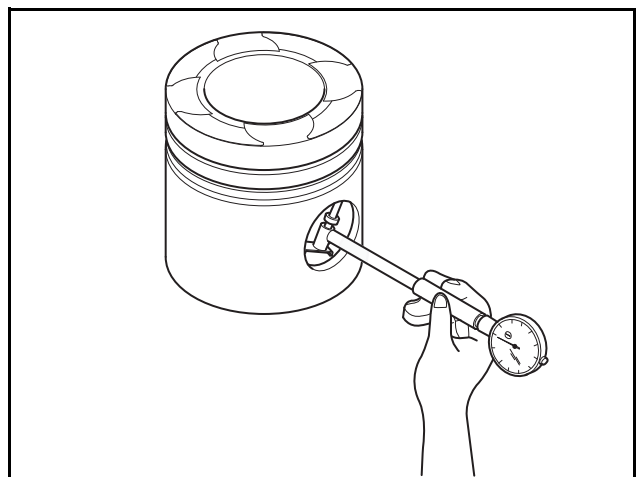

EH8OM008

## 12. Others/Driving system

### Connecting rod

#### Connecting rod inspection

1. Distortion
  - 1) Check the distortion of the connecting rod.
  - 2) Fit the connecting rod to its measuring device and use a feeler gauge to check its distortion.

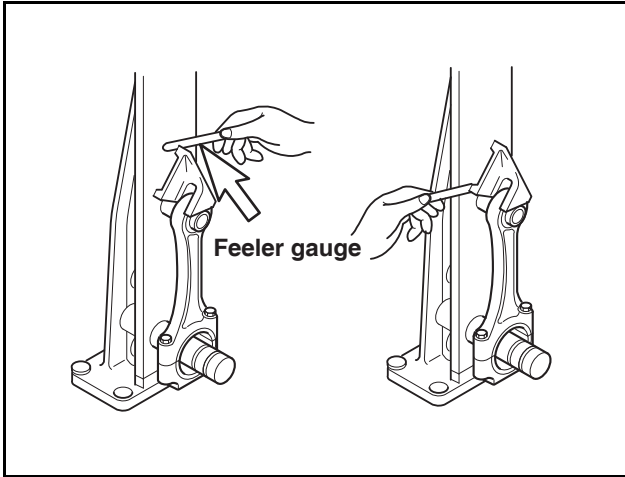

EA0M4034-E

- 3) If the connecting rod is distorted, do not reuse it, but replace it with a new one.
2. Hole parallelization
    - 1) Measure the parallelization of the small end bushing hole and big end bearing hole of the connecting rod.

Note) Use the connecting rod measuring device and feeler gauge for this measurement.

Standard	Allowable limit
0.02 mm	0.1 mm or below

3. Wear
  - 1) Install the connecting rod to the crankshaft.
  - 2) Use a feeler gauge to measure the side clearance at the big end of the connecting rod.
  - 3) Install the connecting rod to the piston.
  - 4) Measure the side clearance at the small end of the connecting rod.
  - 5) If the measurement is over the allowable limit, replace the connecting rod.

Specification	Allowable limit
0.17 - 0.30 mm	0.50 mm

### Others

#### Engine timing

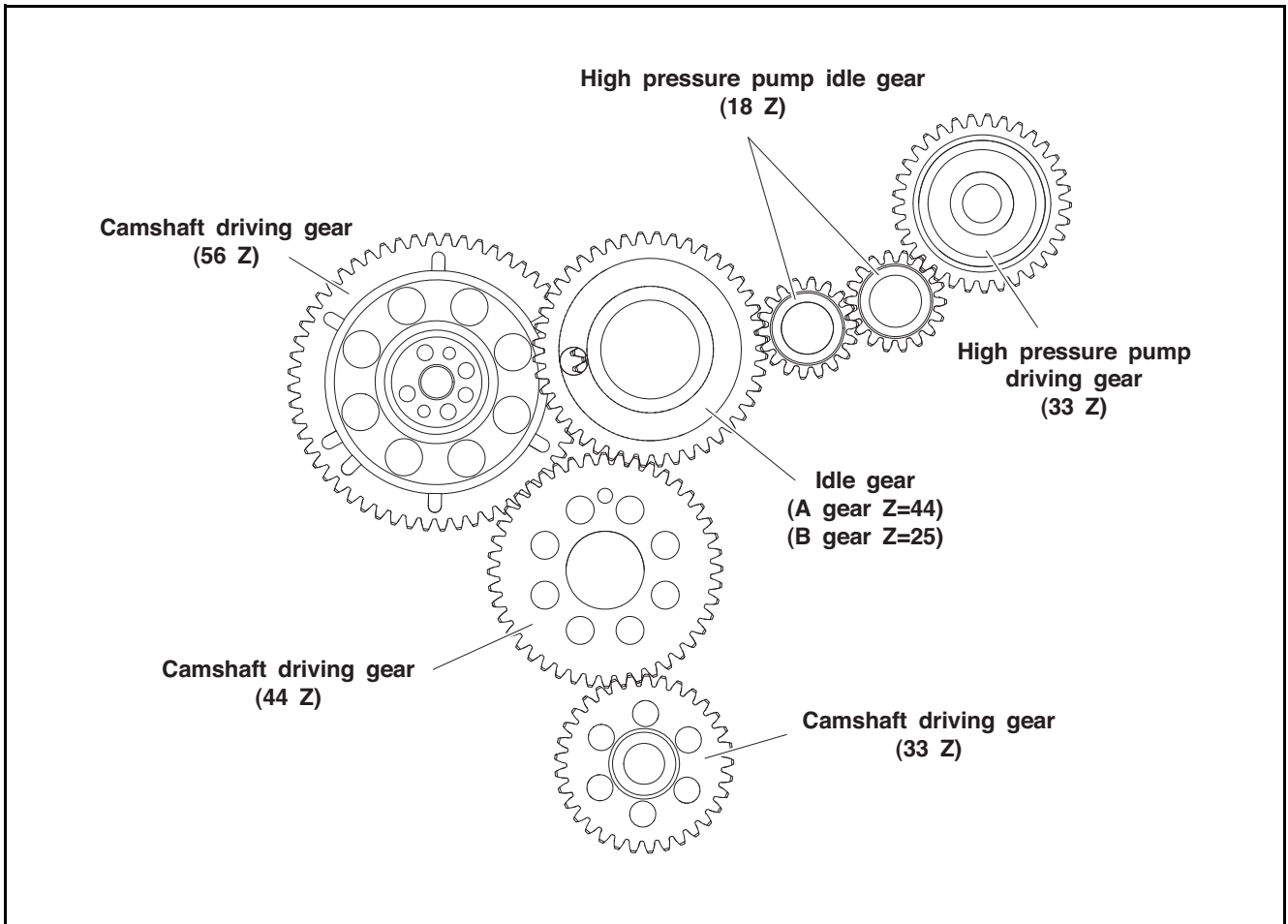

EK4OM009-E

## 12. Others/Driving system

---



# 13. Aftertreatment system

Exhaust gas reduction .....	227
General information .....	227
Aftertreatment muffler and catalyst.....	228
DNOx2.2 system.....	229
Urea tank .....	230
SM (Supply Module) .....	231
DM (Dosing Module).....	232
Urea filter replacement.....	233
DNOx2.2 system components .....	235
Check DNOx2.2 system failures .....	235
Urea quality characteristics.....	237



## Exhaust gas reduction

### General information

The Doosan engine is equipped with the DOC (Diesel Oxidation Catalyst) and SCR (Selective Catalytic Reduction) systems in order to comply with Tier 4 final (and stage IV) emission control. This SCR system consists of the dosing module, supply module, ECU (Engine Control Unit) and other components. The DEF (Diesel Exhaust Fluid) is stored in the DEF tank. Once it is needed, it is pressurized by the supply module and is delivered to the dosing module under a certain level of pressure. The dosing module is attached to the exhaust manifold to spray DEF into the exhaust manifold in front of the SCR system.

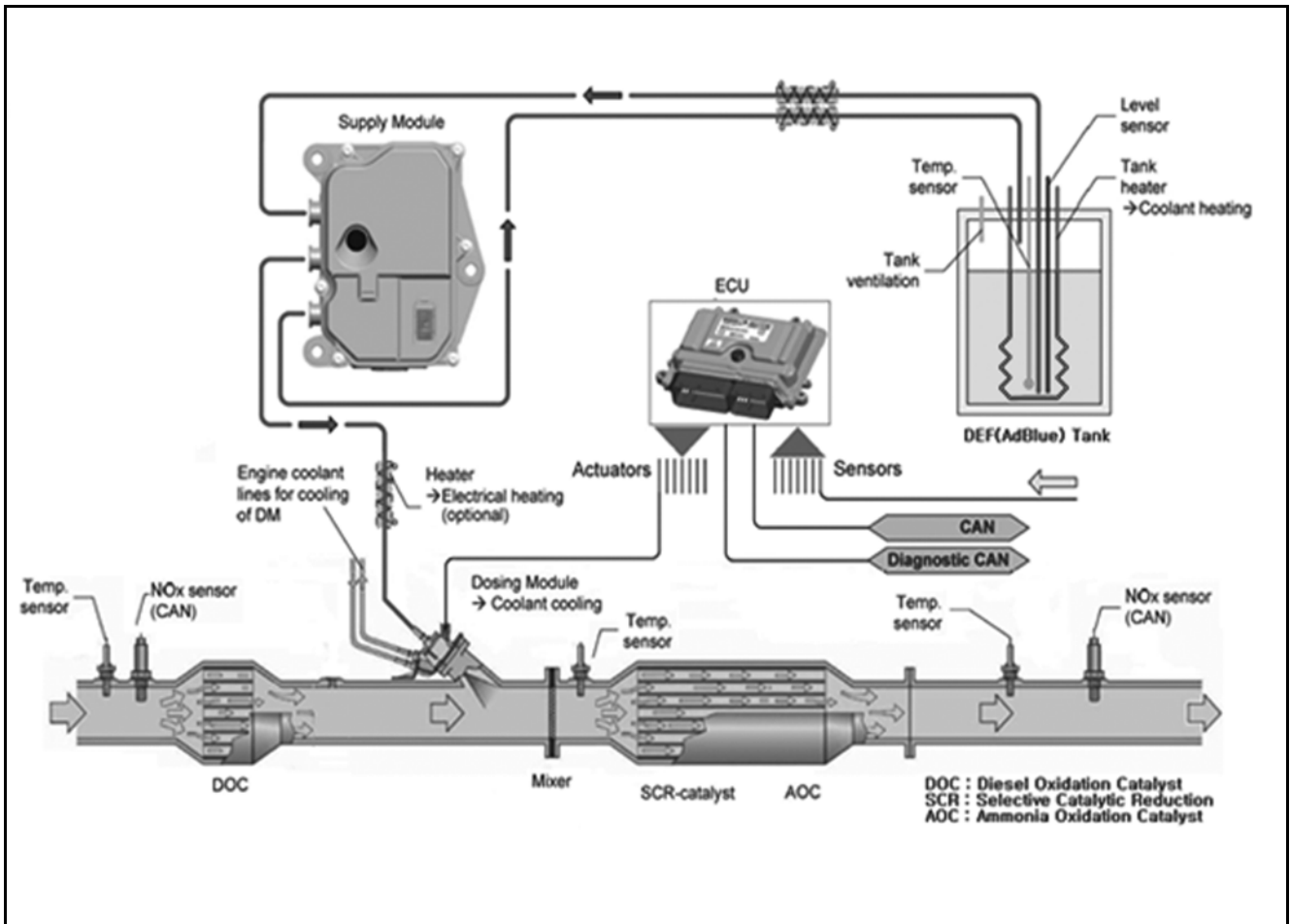

EK00298B

## 13. Aftertreatment system

### Aftertreatment muffler and catalyst

The aftertreatment muffler consists of the DOC muffler, SCR muffler, mixer pipe and other pipes. The DOC muffler contains DOC (Diesel Oxidation Catalyst) while the SCR muffler contains SCR (Selective Catalytic Reduction).

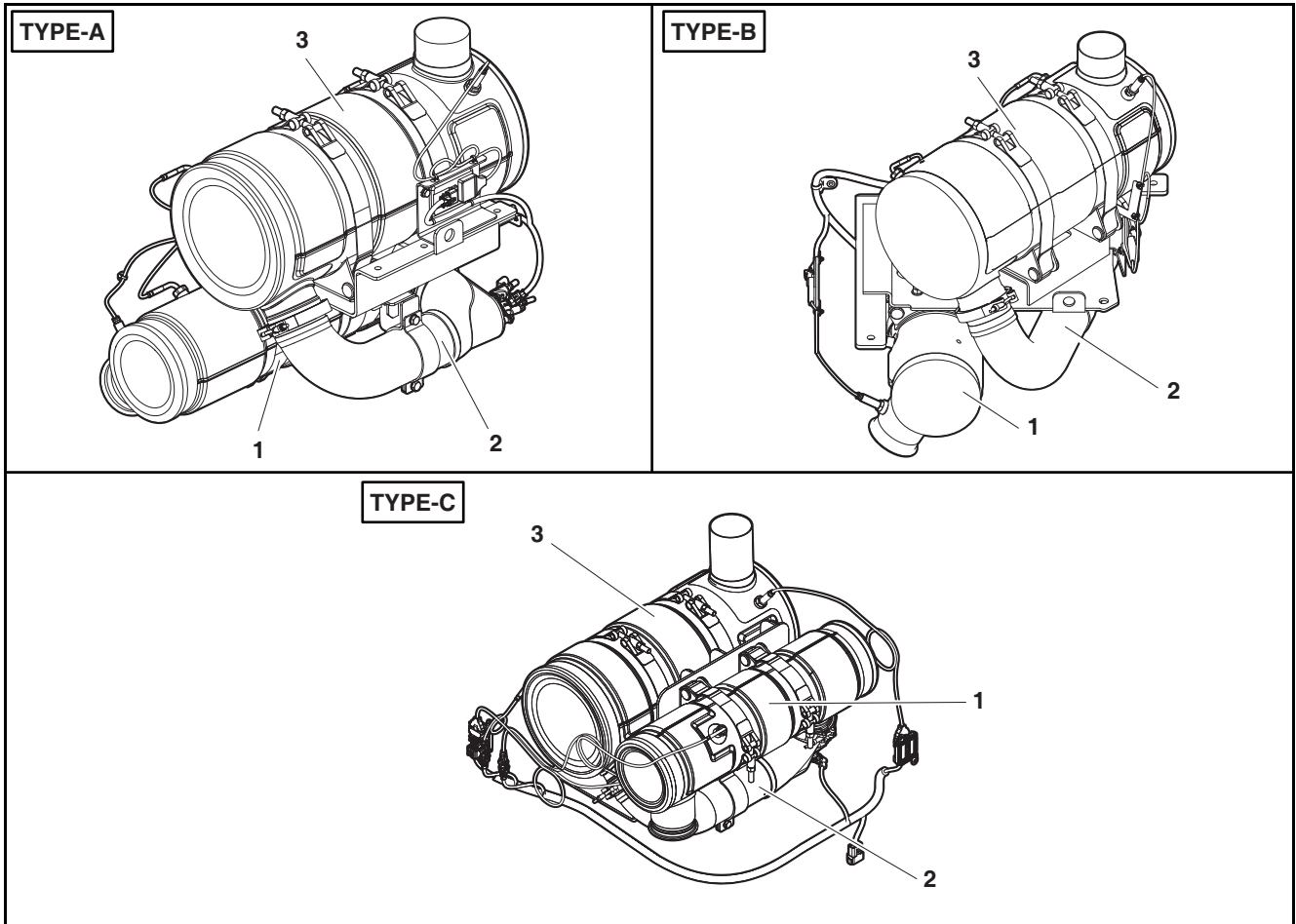

EDL06200020

- 1. DOC converter
- 2. Mixer

- 3. SCR Muffler

## DNox2.2 system

The DNox2.2 system is used to reduce NOx in emissions by spraying urea into the SCR catalyst. It consists of the SM (Supply Module), which functions as a pump, DM (Dosing Module) to spray urea, DCU to control the overall system, urea tank to store urea and urea/cooling water line.

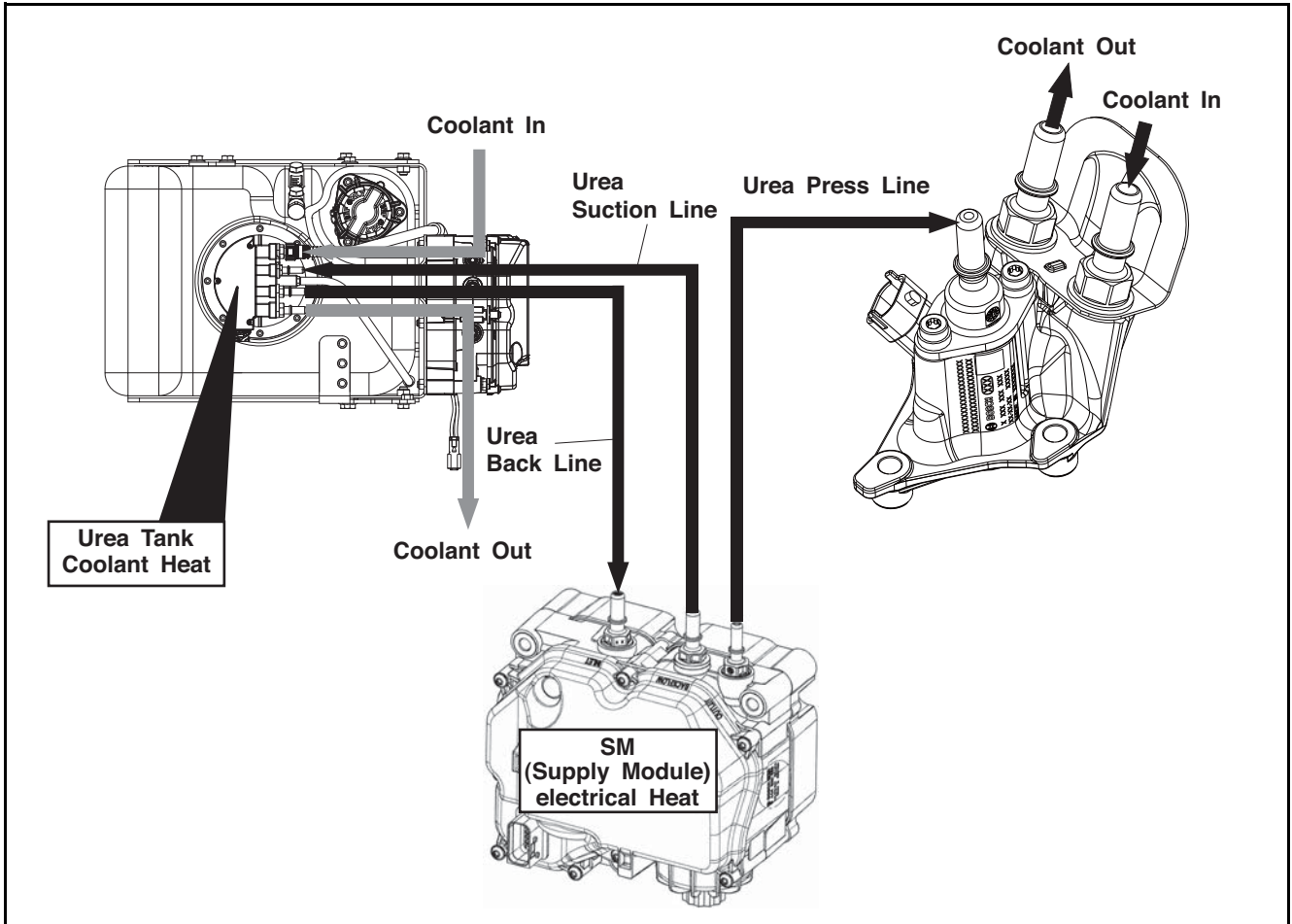

EK00300A

# 13. Aftertreatment system

## Urea tank

The urea tank is used to store urea liquid. Connect lines to the specified positions. Also, be careful not to apply impact to the urea tank during its service.

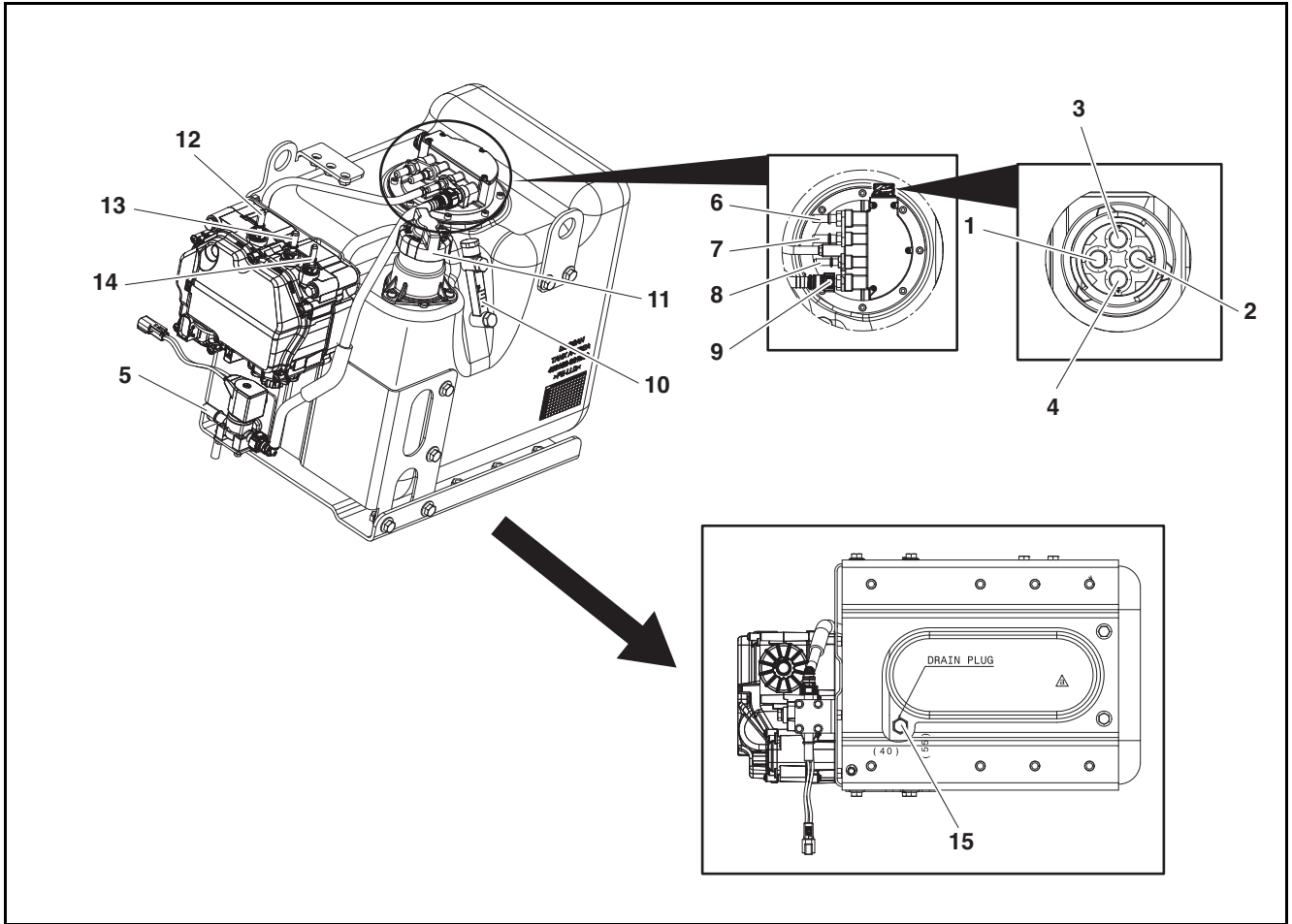

EK00302A

- 1. +24v (Pin No. 1)
- 2. Ground (Pin No. 2)
- 3. Can High (Pin No. 3)
- 4. Can Low (Pin No. 4)
- 5. Coolant Inlet

- 6. Coolant Outlet
- 7. Urea Outlet
- 8. Urea Inlet
- 9. Coolant Inlet
- 10. Level Indicator

- 11. Urea Tank Cap
- 12. Inlet
- 13. Backflow
- 14. Outlet
- 15. Drain Plug

## 13. Aftertreatment system

### SM (Supply Module)

The supply module is used to pressurize DEF in the DEF tank to a certain level and supply this pressurized DEF to the dosing module.

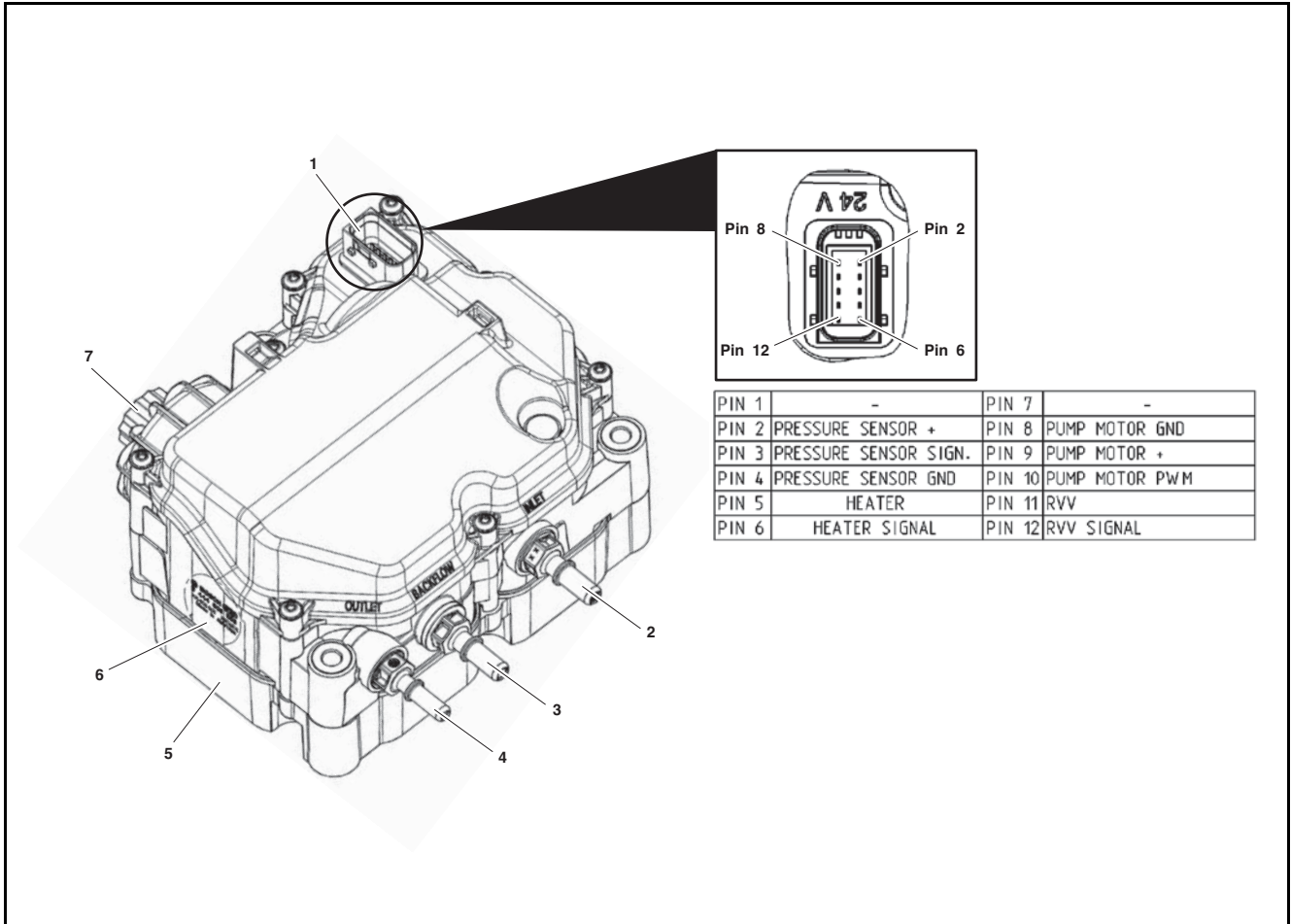

EK00303A

- 1. Connector
- 2. AdBlue Inlet
- 3. AdBlue Backflow Outlet

- 4. AdBlue Outlet
- 5. Cover Plate
- 6. Detail Marking

- 7. Filter Cover

## 13. Aftertreatment system

### DM (Dosing Module)

The dosing module is attached to the exhaust manifold in front of the SCR system to receive DEF from the supply module and spray it into the exhaust manifold.

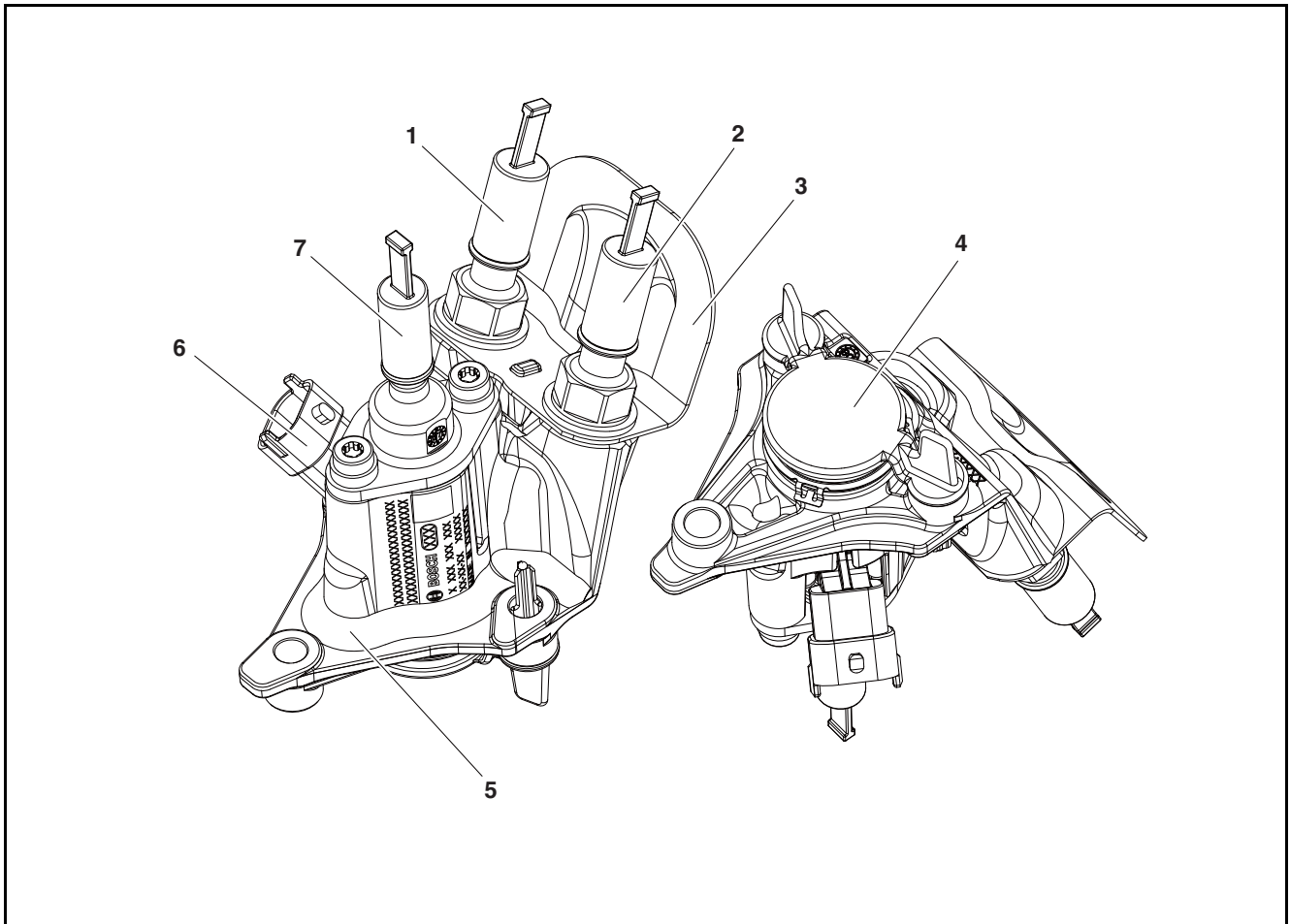

EK00304A

- 1. Coolant Outlet
- 2. Coolant Inlet
- 3. Heat Shield

- 4. Protective Cap
- 5. Cooling Adapter
- 6. Dosing Valve

- 7. AdBlue Inlet



## 13. Aftertreatment system

### Urea filter replacement

1. Remove the filter cover.

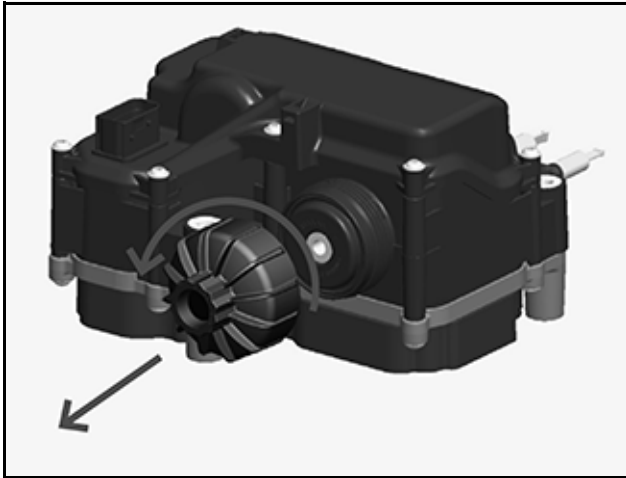

EK00305A

2. Remove the equalizing element.

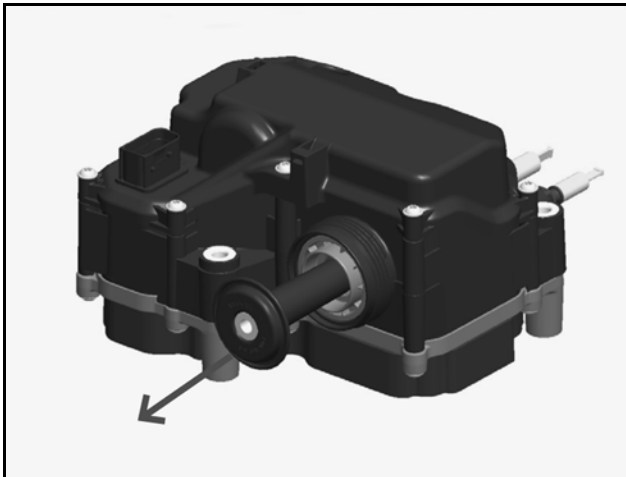

EK00306A

3. Check the color (gray/green) in the filter.



EK00307A

4. Set the color of the mark on the end of the filter removing tool in the same direction with the filter color section.

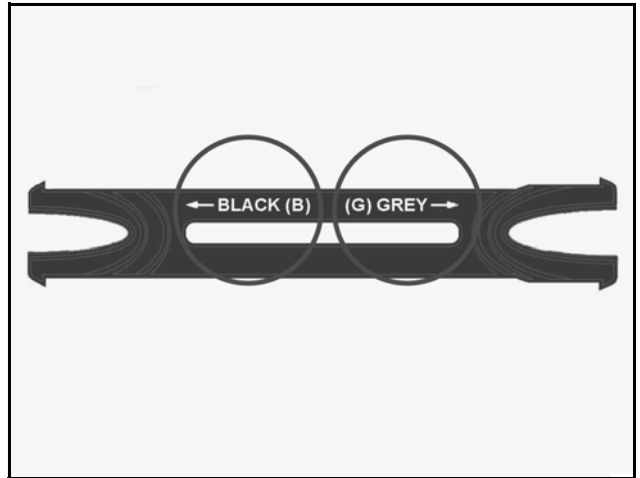

EK00308A

5. Insert the end of the filter removing tool until a clicking sound is heard or engagement with the filter is felt.

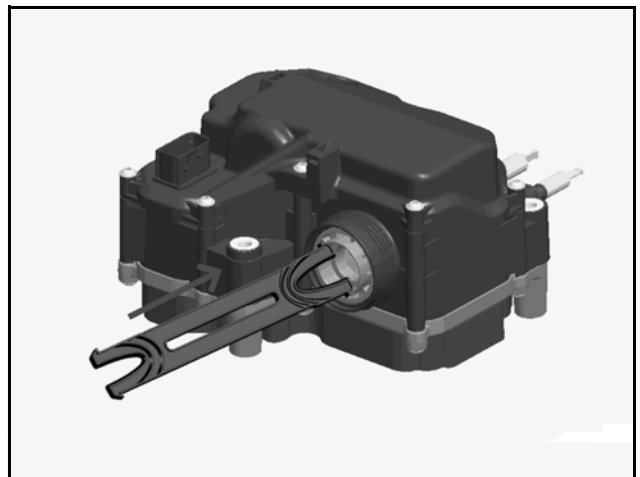

EK00309A

6. Pull the filter removing tool to remove the filter.

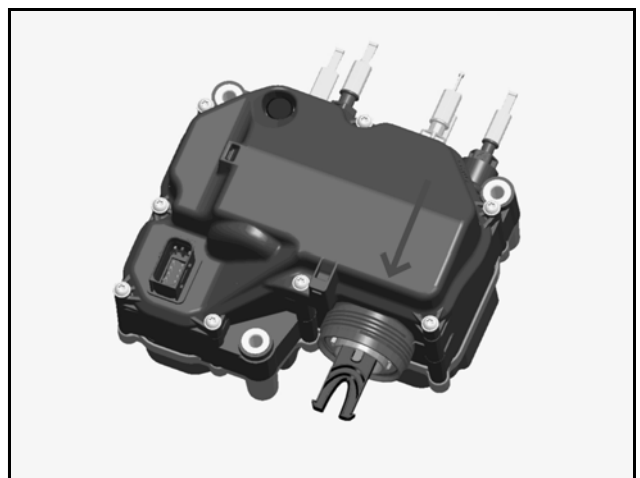

EK00310A

## 13. Aftertreatment system

7. The surface should be kept clean. It can be cleaned with water only.



EK00311A

8. Apply oil to the O-ring and install a new filter.

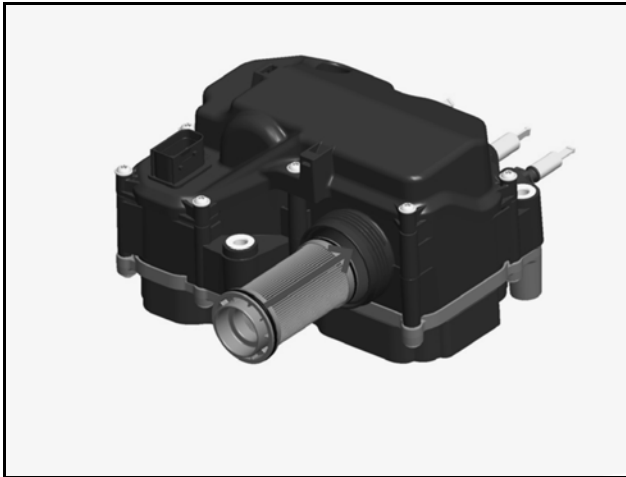

EK00312A

**⚠ CAUTION**

Use Mobil Velocite No. 6 oil from Bosch.

9. Install a new equalizing element.

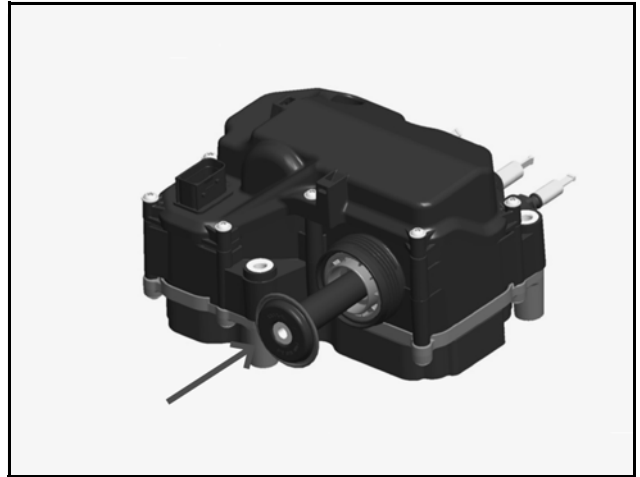

EK00313A

10. Tighten the filter cover to 20 Nm + 5 Nm.



EK00314A

**⚠ CAUTION**

Check that the filter surface is clean. It can be cleaned with water only.

## 13. Aftertreatment system

### DNOx2.2 system components

1. NOx2.2 system are each divided into a machine equipped with the most suitable place, and each part is protected from damage caused by external environment can be configured so.

Note) Urea Tank and Supply Module is equipped with the same Cabin.

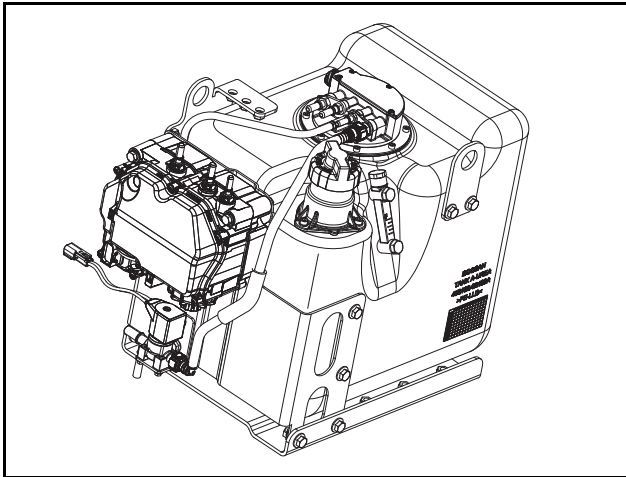

EK00343A

2. Dosing Module(DM) is equipped by a mixer pipe between a DOC and SCR muffler. It is connected with SM in the past Urea Line, the engine coolant Line and 2Pin connector for Urea dosing valve control.

### Check DNOx2.2 system failures

1. Dosing Module

Dosing Module fault is cause of the high temperature exposure of Nozzle Tip injecting Urea, Electric harness contact failure, Urea Hose Line break or poor contact, and more. Visual inspection of DM failure are as follows.

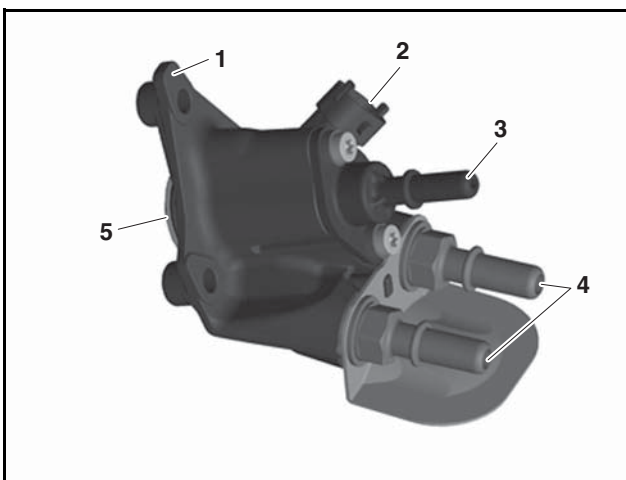

EK00230A

- 1) When replacing DM, DM and bolts is the leakage or damage caused by under tightening bolts or over tightening.

- 2) Electric connector misassembly or debris contamination inside of connector.
- 3) Urea leakage is caused by Urea Line misassembly.
- 4) Coolant leakage is caused by coolant line misassembly. The high temperature exposure of DM is caused by disconnected.
- 5) The high temperature exposure of DM is caused by gasket misassembly.
- 6) Urea leakage is caused by gasket reuse.

2. Supply Module

The Supply Module(SM) failure mode is associated with Urea Line and Electric Connector damage and poor connection. When replacing Urea main filter regularly, Supply module failure can occur caused by disassembly.

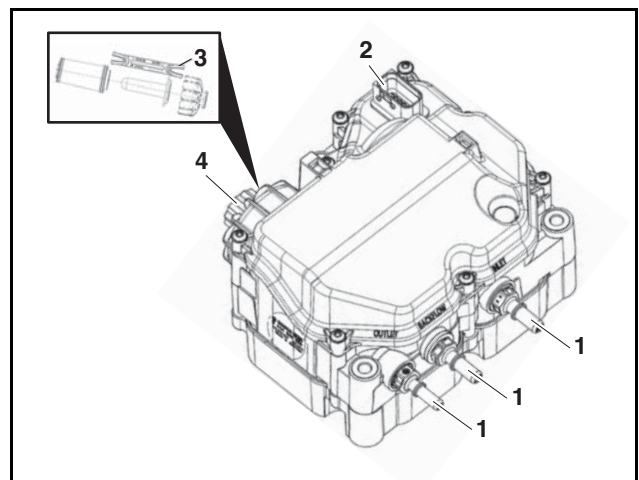

EK00344A

### CAUTION

**When replacing new filter, open the package on the verge of replacement.**

- 1) When connecting Urea Line, the failure caused by Urea Line misassembly.
- 2) Electric connector misassembly or debris contamination inside of connector.
- 3) When replacing SM Filter, the damage caused by not using the special tool. Also, it caused by filter remnants inside SM filter.
- 4) When replacing filter, the Urea Cap damage is caused by over tightening and the filter detachment is caused by not tightening.

# 13. Aftertreatment system

## 3. UREA TANK

Urea Tank is keeping the urea solution. Assembly connected line to correct location. When maintenance of Urea Tank, be careful not to external impacts.

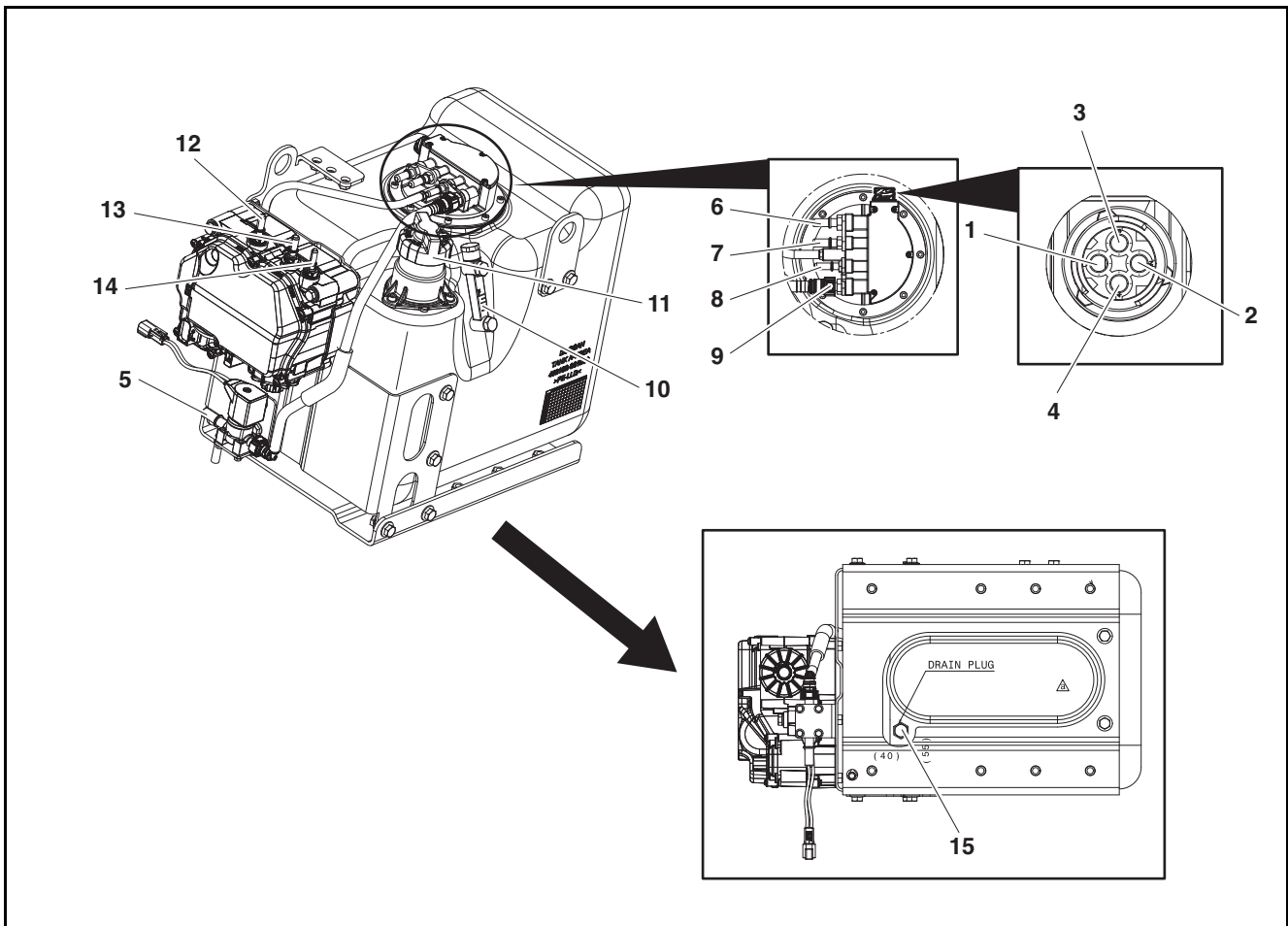

EK00302A

1) Urea inlet hose and Backflow hose are incompatible, Do not use them together. Be careful to damage the connector, assemble the connector.

### **⚠ CAUTION**

**Urea inlet hose is marked red color, Backflow hose is marked yellow color.**

- 2) Make sure that Urea Tank fixing Bracket Mount is tightened. If it is not tightened, it could occur the damage caused by vibration.
- 3) Make sure that the connection condition of Tank temperature and level sensor connector. Be careful to damage connector and be contaminated debris.
- 4) Assembly coolant line to correct location. If it is not tightened, it could leak coolant.

5) Make sure that the connection condition of Urea Line Heater(2-PIN). Not running a heater in winter season there is a danger of frost.

- 4. Muffler and other pipes  
It is no necessary to replace, disassemble and move mounted muffler and other pipes except by failure caused by external impact. Tighten the each parts at tightening torque not to leakage, when replacing, disassembling and moving muffler and other pipes caused by failure.

## 13. Aftertreatment system

### Urea quality characteristics

CHARACTERISTICS	UNIT	LIMITS		TEST METHODS
		MIN.	MAX.	
Urea content <sup>a</sup>	%(m/m) <sup>b</sup>	31.8	33.2	ISO 22241-2 Annex B <sup>c</sup> ISO 22241-2 Annex C <sup>c</sup>
Density at 20°C <sup>d</sup>	kg/m <sup>3</sup>	1,087	1,093	ISO 3675 or ISO 12185
Refractive index at 20°C <sup>e</sup>	-	1.3814	1.3843	ISO 22241 2 Annex C
Alkalinity as NH <sub>3</sub>	%(m/m) <sup>b</sup>	-	0.2	ISO 22241 2 Annex D
Biuret	%(m/m) <sup>b</sup>	-	0.3	ISO 22241 2 Annex E
Aldehydes	mg/kg	-	5	ISO 22241 2 Annex F
Insoluble matter	mg/kg	-	20	ISO 22241 2 Annex G
Phosphate (PO <sub>4</sub> )	mg/kg	-	0.5	ISO 22241 2 Annex H
Calcium	mg/kg	-	0.5	ISO 22241 2 Annex I
Iron	mg/kg	-	0.5	
Copper	mg/kg	-	0.2	
Zinc	mg/kg	-	0.2	
Chromium	mg/kg	-	0.2	
Nickel	mg/kg	-	0.2	
Aluminium	mg/kg	-	0.5	
Magnesium	mg/kg	-	0.5	
Sodium	mg/kg	-	0.5	
Potassium	mg/kg	-	0.5	
Identity	-	identical to reference		ISO 22241 2 Annex J

a. Target value 32.5%(m/m).

b. for the purposes of this International Standard, the term “%(m/m)” is used to represent the mass fraction of a material.

c. Calculated without subtracting nitrogen from ammonia.

d. Target value 1,090 kg/m<sup>3</sup>

e. Target value 1.3829

Should it be necessary to add a tracer to AUS 32, it shall be ensured that the quality of AUS 32 specified in this Table is not impaired and that the tracer does not damage the SCR system.

Note) In establishment of these limit values, the terms of ISO 4259 have been applied in fixing a maximum and minimum value, a minimum difference of  $4 \times R$  ( $R$  is the Reproducibility of the test method) has been taken into account. However, in case of urea content, the  $4 \times R$  rule has not been applied in order to keep the high quality.

Note) The values quoted regarding urea content, density and refractive index are “true values” (see ISO 4259 for definition of true values).

Note) The manufacturer of AUS 32 should aim at the target values defined in footnotes a, d and e.

Note) Should it be necessary to clarify the questions as to whether a given urea solution meets the requirement of the specifications, the terms of ISO 4259 should be applied.

## 13. Aftertreatment system

---