

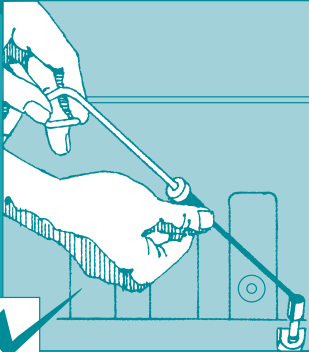

Owners Manual QSC8.3 and QSL9 Engine

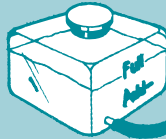

Cummins Customer Assistance Center

1-800-DIESELS™ (1-800-343-7357)

APPLICABLE ONLY IN U.S.A. AND CANADA



Owners Manual QSC8.3 and QSL9 Engine

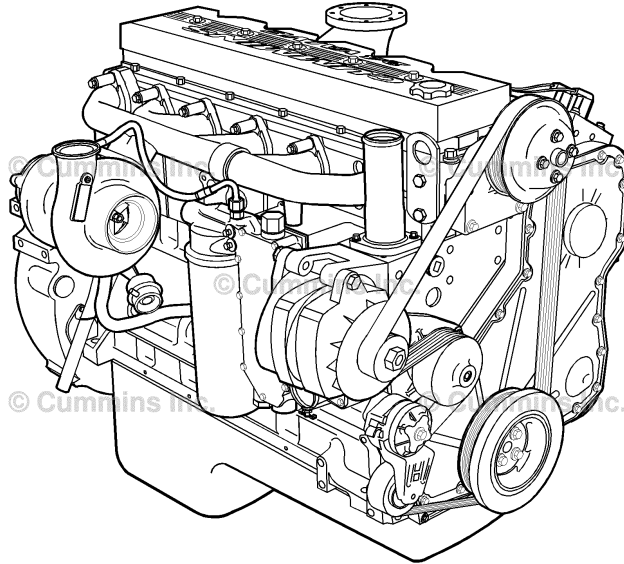

00d00016

Copyright© 2013
Cummins Inc.
All rights reserved

Bulletin 4915536
Printed 13-SEPTEMBER-2013

Foreword

This manual contains information for the correct operation and maintenance of your Cummins engine.

Read and follow all safety instructions. Refer to the WARNING in the General Safety Instructions in Section i - Introduction.

Keep this manual with the equipment. If the equipment is traded or sold, give the manual to the new owner.

The information, specifications, and recommended maintenance guidelines in this manual are based on information in effect at the time of printing. Cummins Inc. reserves the right to make changes at any time without obligation. If you find differences between your engine and the information in this manual, contact your local Cummins Authorized Repair Location or call 1-800-DIESELS (1-800-343-7357) toll free in the U.S. and Canada.

The latest technology and the highest quality components were used to produce this engine. When replacement parts are needed, we recommend using only genuine Cummins or ReCon® exchange parts.

NOTE: Warranty information is located in Section W. Make sure you are familiar with the warranty or warranties applicable to your engine.

Table of Contents

	Section
Introduction	i
Engine and System Identification	E
Operating Instructions	1
Maintenance Guidelines	2
Service Literature	L
Maintenance Specifications	V
Warranty	W
Back	back

Important Reference Numbers

Fill in the part name and number in the blank spaces provided below. This will give you a reference whenever service or maintenance is required.

Name	Number	Number
Engine Model		
Engine Serial Number (ESN)		
Control Parts List (CPL)		
Fuel Pump Part Number		
Electronic Control Module (ECM)		
Electronic Control Module Serial Numbers (ECM)		
Filter Part Numbers:		
• Air Cleaner Element		
• Lubricating Oil		
• Fuel		
• Fuel-Water Separator		
• Coolant		
• Crankcase Ventilation		
• Cummins Particulate Filter		
Governor Control Module (GCM) (if applicable)		
Belt Part Numbers:		

•		
•		
•		
Clutch or Marine Gear (if applicable):		
• Model		
• Serial Number		
• Part Number		
• Oil Type		
• Sea Water Pump		
- Model		
- Part Number		

Section i - Introduction

Section Contents

	Page
Acronyms and Abbreviations	i-7
General Information.....	i-7
General Safety Instructions	i-3
Important Safety Notice.....	i-3
Illustrations	i-2
General Information.....	i-2
Symbols	i-1
General Information.....	i-1

This Page Left Intentionally Blank

Symbols

General Information

The following symbols have been used in this manual to help communicate the intent of the instructions. When one of the symbols appears, it conveys the meaning defined below:



WARNING - Serious personal injury or extensive property damage can result if the warning instructions are not followed.



CAUTION - Minor personal injury can result or a part, an assembly, or the engine can be damaged if the caution instructions are not followed.



Indicates a **REMOVAL** or **DISASSEMBLY** step.



Indicates an **INSTALLATION** or **ASSEMBLY** step.



INSPECTION is required.



CLEAN the part or assembly.



PERFORM a mechanical or time **MEASUREMENT**.



LUBRICATE the part or assembly.



Indicates that a **WRENCH** or **TOOL SIZE** will be given.



TIGHTEN to a specific torque.



PERFORM an electrical **MEASUREMENT**.



Refer to another location in this manual or another publication for additional information.



The component weighs 23 kg [50 lb] or more. To avoid personal injury, use a hoist or get assistance to lift the component.

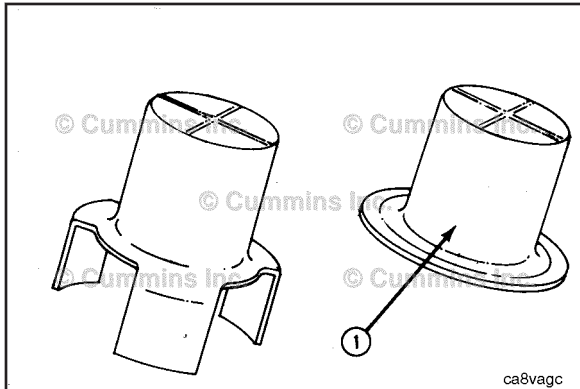
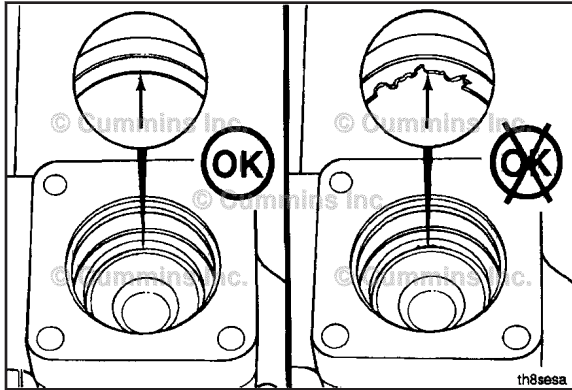

Illustrations

General Information

Some of the illustrations throughout this manual are generic and will **not** look exactly like the engine or parts used in your application. The illustrations can contain symbols to indicate an action required and an acceptable or **not** acceptable condition.

The illustrations are intended to show repair or replacement procedures. The procedure will be the same for all applications, although the illustration can differ.

General Safety Instructions

Important Safety Notice



Improper practices, carelessness, or ignoring the warnings can cause burns, cuts, mutilation, asphyxiation or other personal injury or death.

Read and understand all of the safety precautions and warnings before performing any repair. This list contains the general safety precautions that **must** be followed to provide personal safety. Special safety precautions are included in the procedures when they apply.

- Work in an area surrounding the product that is dry, well lit, ventilated, free from clutter, loose tools, parts, ignition sources and hazardous substances. Be aware of hazardous conditions that can exist.
- **Always** wear protective glasses and protective shoes when working.
- Rotating parts can cause cuts, mutilation or strangulation.
- Do **not** wear loose-fitting or torn clothing. Remove all jewelry when working.
- Disconnect the battery (negative [-] cable first) and discharge any capacitors before beginning any repair work. Disconnect the air starting motor if equipped to prevent accidental engine starting. Put a "Do **Not** Operate" tag in the operator's compartment or on the controls.
- Use **ONLY** the proper engine barring techniques for manually rotating the engine. Do **not** attempt to rotate the crankshaft by pulling or prying on the fan. This practice can cause serious personal injury, property damage, or damage to the fan blade(s) causing premature fan failure.
- If an engine has been operating and the coolant is hot, allow the engine to cool before slowly loosening the filler cap to relieve the pressure from the cooling system.

- **Always** use blocks or proper stands to support the product before performing any service work. Do **not** work on anything that is supported **ONLY** by lifting jacks or a hoist.
- Relieve all pressure in the air, oil, fuel, and cooling systems before any lines, fittings, or related items are removed or disconnected. Be alert for possible pressure when disconnecting any device from a system that utilizes pressure. Do **not** check for pressure leaks with your hand. High pressure oil or fuel can cause personal injury.
- To reduce the possibility of suffocation and frostbite, wear protective clothing and **ONLY** disconnect liquid refrigerant (Freon) lines in a well ventilated area. To protect the environment, liquid refrigerant systems **must** be properly emptied and filled using equipment that prevents the release of refrigerant gas (fluorocarbons) into the atmosphere. Federal law requires capturing and recycling refrigerant.
- To reduce the possibility of personal injury, use a hoist or get assistance when lifting components that weigh 23 kg [50 lb] or more. Make sure all lifting devices such as chains, hooks, or slings are in good condition and are of the correct capacity. Make sure hooks are positioned correctly. **Always** use a spreader bar when necessary. The lifting hooks **must not** be side-loaded.
- Corrosion inhibitor, a component of SCA and lubricating oil, contains alkali. Do **not** get the substance in eyes. Avoid prolonged or repeated contact with skin. Do **not** swallow internally. In case of contact, immediately wash skin with soap and water. In case of contact, immediately flood eyes with large amounts of water for a minimum of 15 minutes. IMMEDIATELY CALL A PHYSICIAN. KEEP OUT OF REACH OF CHILDREN.
- Naptha and Methyl Ethyl Ketone (MEK) are flammable materials and **must** be used with caution. Follow the manufacturer's instructions to provide complete safety when using these materials. KEEP OUT OF REACH OF CHILDREN.
- To reduce the possibility of burns, be alert for hot parts on products that have just been turned off, exhaust gas flow, and hot fluids in lines, tubes, and compartments.
- **Always** use tools that are in good condition. Make sure you understand how to use the tools before performing any service work. Use **ONLY** genuine Cummins® or Cummins ReCon® replacement parts.

- **Always** use the same fastener part number (or equivalent) when replacing fasteners. Do **not** use a fastener of lesser quality if replacements are necessary.
- When necessary, the removal and replacement of any guards covering rotating components, drives, and/or belts should only be carried out by a trained technician. Before removing any guards the engine **must** be turned off and any starting mechanisms **must** be isolated. All fasteners **must** be replaced on re-fitting the guards.
- Do **not** perform any repair when fatigued or after consuming alcohol or drugs that can impair your functioning.
- Some state and federal agencies in the United States of America have determined that used engine oil can be carcinogenic and can cause reproductive toxicity. Avoid inhalation of vapors, ingestion, and prolonged contact with used engine oil.
- Do **not** connect the jumper starting or battery charging cables to any ignition or governor control wiring. This can cause electrical damage to the ignition or governor.
- **Always** torque fasteners and fuel connections to the required specifications. Overtightening or undertightening can allow leakage. This is critical to the natural gas and liquefied petroleum gas fuel and air systems.
- **Always** test for fuel leaks as instructed, as odorant can fade.
- Close the manual fuel valves prior to performing maintenance and repairs, and when storing the vehicle inside.
- Coolant is toxic. If **not** reused, dispose of in accordance with local environmental regulations.
- The catalyst reagent contains urea. Do **not** get the substance in your eyes. In case of contact, immediately flood eyes with large amounts of water for a minimum of 15 minutes. Avoid prolonged contact with skin. In case of contact, immediately wash skin with soap and water. Do **not** swallow internally. In the event the catalyst reagent is ingested, contact a physician immediately.
- The catalyst substrate contains Vanadium Pentoxide. Vanadium Pentoxide has been determined by the State of California to cause cancer. Always wear protective gloves and eye protection when handling the catalyst assembly. Do not get the catalyst material in your eyes. In Case of contact, immediately flood eyes with large amounts of

water for a minimum of 15 minutes. Avoid prolonged contact with skin. In case of contact, immediately wash skin with soap and water.

- The Catalyst substrate contains Vanadium Pentoxide. Vanadium Pentoxide has been determined by the State of California to cause cancer. In the event the catalyst is being replaced, dispose of in accordance with local regulations.
- California Proposition 65 Warning - Diesel engine exhaust and some of its constituents are known to the State of California to cause cancer, birth defects, and other reproductive harm.

Acronyms and Abbreviations

General Information

The following list contains some of the acronyms and abbreviations used in this manual.

ANSI	American National Standards Institute
API	American Petroleum Institute
ASTM	American Society of Testing and Materials
ATDC	After Top Dead Center
BTU	British Thermal Unit
BTDC	Before Top Dead Center
°C	Celsius
CAN	Controller Area Network
CO	Carbon Monoxide
CCA	Cold Cranking Amperes
CARB	California Air Resources Board
C.I.B.	Customer Interface Box
C.I.D.	Cubic Inch Displacement
CNG	Compressed Natural Gas
CPL	Control Parts List
cSt	Centistokes
DEF	Diesel Exhaust Fluid

DOC	Diesel Oxidation Catalyst
DPF	Diesel Particulate Filter
ECM	Engine Control Module
EFC	Electronic Fuel Control
EGR	Exhaust Gas Recirculation
EPA	Environmental Protection Agency
°F	Fahrenheit
ft-lb	Foot-Pound Force
FMI	Failure Mode Identifier
GVW	Gross Vehicle Weight
Hg	Mercury
hp	Horsepower
H₂O	Water
inHg	Inches of Mercury
in H₂O	Inches of Water
ICM	Ignition Control Module
IEC	International Electrotechnical Commission
km/l	Kilometers per Liter
kPa	Kilopascal
LNG	Liquid Natural Gas
LPG	Liquified Petroleum Gas

LTA	Low Temperature Aftercooling
MCRS	Modular Common Rail System
MIL	Malfunction Indicator Lamp
MPa	Megapascal
mph	Miles Per Hour
mpq	Miles Per Quart
N•m	Newton-meter
NOx	Mono-Nitrogen Oxides
NG	Natural Gas
O2	Oxygen
OBD	On-Board Diagnostics
OEM	Original Equipment Manufacturer
OSHA	Occupational Safety and Health Administration
PID	Parameter Identification Descriptions
ppm	Parts Per Million
psi	Pounds Per Square Inch
PTO	Power Takeoff
REPTO	Rear Power Take Off
RGT	Rear Gear Train
rpm	Revolutions Per Minute
SAE	Society of Automotive Engineers

SCA	Supplemental Coolant Additive
SCR	Selective Catalytic Reduction
STC	Step Timing Control
SID	Subsystem Identification Descriptions
TDC	Top Dead Center
VDC	Volts of Direct Current
VGT	Variable Geometry Turbocharger
VS	Variable Speed
VSS	Vehicle Speed Sensor

Section E - Engine and System Identification

Section Contents

	Page
Cummins® Service Engine Model Product Identification	E-6
General Information.....	E-6
Engine Identification	E-1
Cummins® Engine Nomenclature.....	E-4
ECM Dataplate.....	E-5
Engine Dataplate.....	E-1
Fuel Injection Pump Dataplate.....	E-4

This Page Left Intentionally Blank

Engine Identification

Engine Dataplate

 Cummins, Inc. Box 3000 Columbus, Indiana 47202-3000 <small>Warning Labels May Result And Warranty Is Void If Fuel Rate RPM Or Altitudes Exceed Published Maximum Values For This Model And Application. Date of Mfg. Made in U.S.A.</small>	Engine Cert. I.D.	C.I.D./ L	SERIES	CPL	Engine Serial No.
	Timing TDC				Injector P/N.
	Valve lash cold int. Exh.				Cust Spec.
	Firing Order				Rated HP at rpm
	Low idle RPM				Fuel rate at rated HP mm 3/stroke
	E.C.S.				Model Name

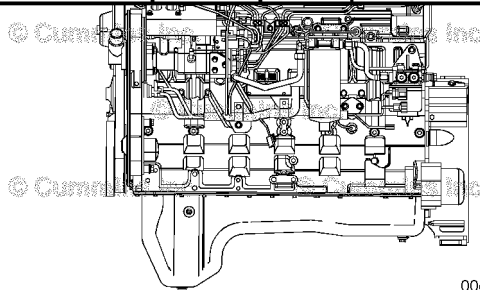

00d00001

The engine dataplate provides important information about the engine. The engine serial number (ESN) and control part list (CPL) provide information for service and for ordering parts. The engine dataplate **must not** be changed unless approved by Cummins Inc.

3 2 1

 Cummins Inc. Columbus, Indiana 47202-3005 Warning Injury May Result And Warranty is Voided if Fuel Rate Or Altitudes Exceed Published Maximum Values For This Model And Application. Date of Mfg. 19951130 Made in U.S.A. 3906610	Engine Cert. I.D.	C.I.D./ L	SERIES	CPL	Engine Serial No. 45275188
	Timing TDC	359 5.9 403 2079			Cust Spec.
	Valve lash cold	0.010 int. 0.020 Exh.			Rated HP 0 at 0 rpm
	Firing Order	1 5 3 6 2 4			Fuel rate at rated HP 0mm 3/stroke
	Low Idle RPM	800		E.C.S.	Fuel rate at rated HP 0mm 3/stroke
	4				

00900061

Have the following engine data available when communicating with a Cummins® Authorized Repair Location:

- 1 Engine serial number (ESN)
- 2 Control parts list (CPL)
- 3 Model
- 4 Horsepower and rpm rating.

QSC8.3 and QSL9
Section E - Engine and System Identification

NOTE: Depending on the manufacturing plant, calibration data may also be found on the engine dataplate.

If the engine dataplate (1) is **not** legible, the engine serial number (ESN) (2) can be found on the engine block, on top of the lubricating oil cooler housing. Additional engine information is on the ECM dataplate.

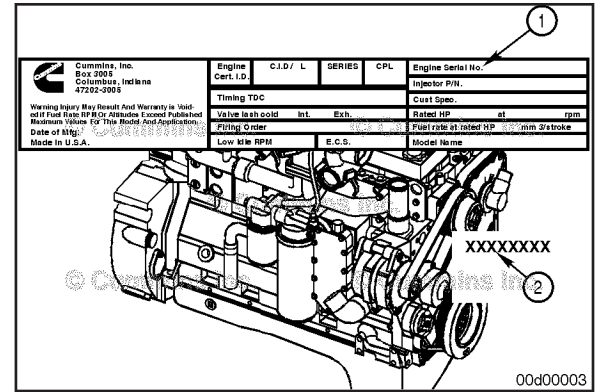

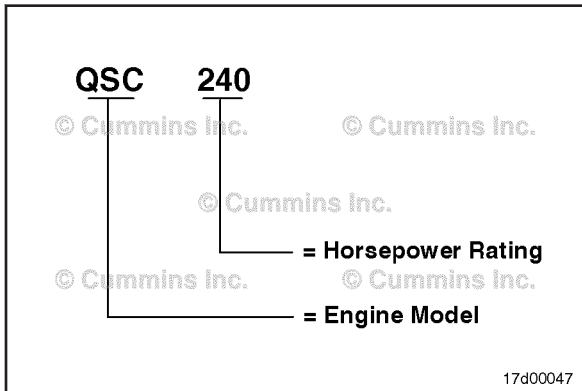

Cummins® Engine Nomenclature

The Cummins® engine nomenclature provides the engine model and horsepower rating.

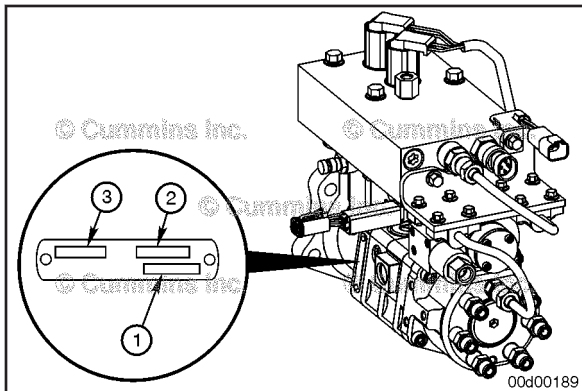

Fuel Injection Pump Dataplate

The Cummins® Accumulator Pump System (CAPS) fuel injection pump dataplate is located on the side of the injection pump. The dataplate contains the following information:

- 1 Cummins® part number
- 2 Pump serial number
- 3 Factory code.

ECM Dataplate

The ECM dataplate is located on the front of the ECM.

The following information is found on the ECM dataplate:

- ECM part number (PN)
- ECM serial number (SN)
- ECM date code (DC)
- Engine serial number (ESN)
- ECM Code (identifies the software in the ECM).

NOTE: The presence of an ECM dataplate depends on the manufacturing plant and the date the engine was manufactured. If an ECM dataplate was **not** installed by the manufacturing plant, calibration data can be found on the engine dataplate.

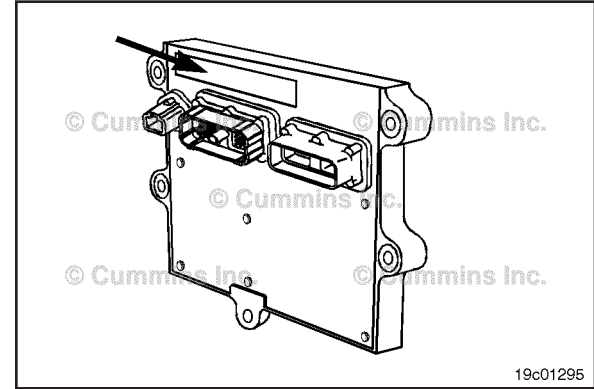

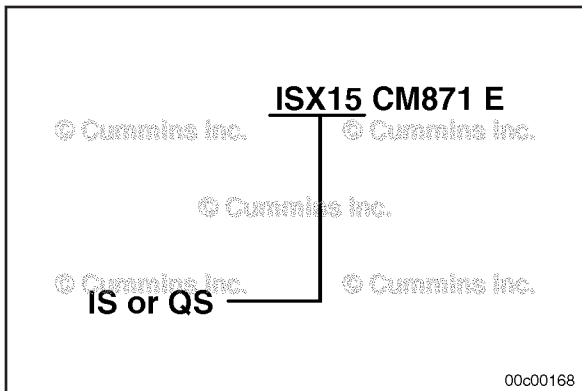

Cummins® Service Engine Model Product Identification

General Information

The Cummins® Service Engine Model Nomenclature procedure describes how engines are identified within Cummins service organization. This method was introduced for models after and including manufacture year 2007.

Electronic engines are identified by the first two letters, either an "IS" for On-Highway automotive or "QS" for Off-Highway industrial market applications.

QSC8.3 and QSL9
Section E - Engine and System Identification

The third letter is the engine platform designation followed by the engine liter size.

If the engine operates on a fuel type other than diesel, the type will be identified after the liter size.

Cummins® Service Engine Model Product Identification
Page E-7

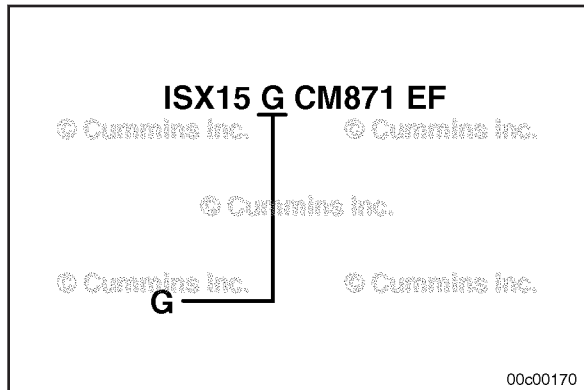
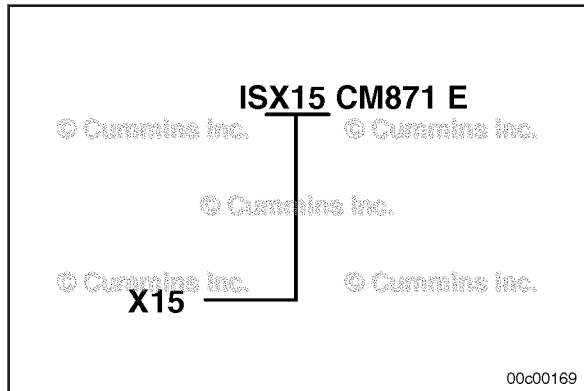

The control system is identified with the letters "CM" followed by the control system model number.

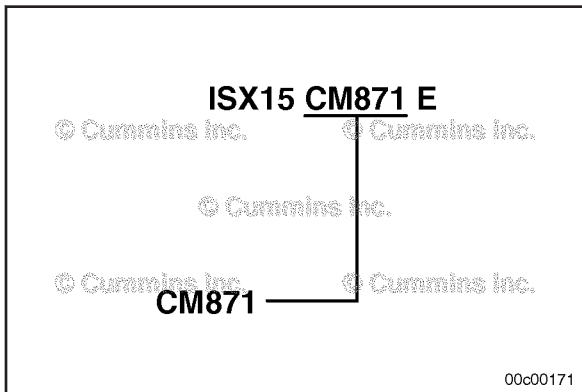

The technology identifier after the control system designates the prevailing technology used with the engine. (See table in this procedure for letter designations.)

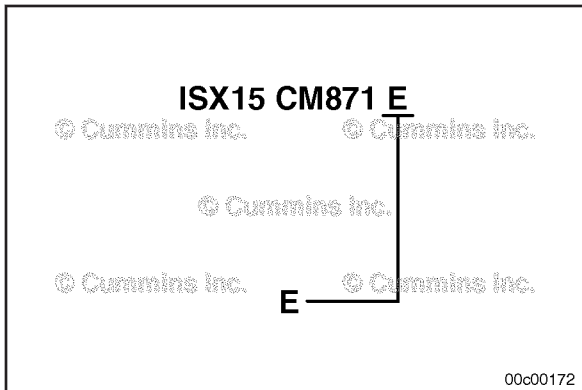

QSC8.3 and QSL9
Section E - Engine and System Identification

Example:

- 1 On-Highway automotive "X" 15 liter engine
- 2 Control system number 871
- 3 Technology supported; Electric EGR and Diesel Particulate Filter

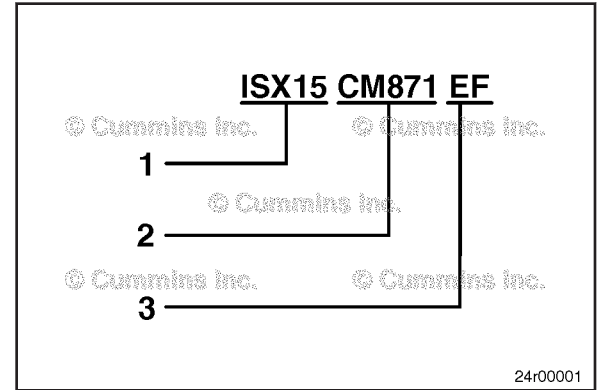

Technology	Name	Suffix
Exhaust Gas Recirculation	Not used	None
	Pneumatic	P
	Electric	E
Diesel Particulate Filter (DPF)	Not used	None
	Full Flow DPF	F
	Partial Flow DPF	F2
Diesel Oxidation Catalyst	Not used	None
	DOC	C
3-Way Oxidation Catalytic Converter	Not used	None
	3-Way Catalyst	J
Selective Catalytic Reduction System	Not used	None
	Air Driven	S
	Airless	A
Nox Sensor	Not used	None
	Nox Sensor	N
Modular Common Rail System	Used only on QSK19, 38, 50 , 60 HHP Engines	MCRS
Integrated Dosing Control Unit	Not Used	None
	Integrated	I

Section 1 - Operating Instructions

Section Contents

	Page
Cold Weather Starting	1-6
General Information.....	1-6
Using Starting Aids.....	1-7
Electromagnetic Interference (EMI)	1-12
General Information.....	1-12
System EMI Radiation Levels.....	1-13
System EMI Susceptibility.....	1-13
Engine Operating Range	1-10
General Information.....	1-10
Engine Shutdown	1-12
General Information.....	1-12
Normal Starting Procedure	1-4
General Information.....	1-4
Operating Instructions - Overview	1-1
General Information.....	1-1
Operating the Engine	1-8
Normal.....	1-8
Winterfronts and Shutters.....	1-9
Starting Procedure After Extended Shutdown or Oil Change	1-7
General Information.....	1-7

This Page Left Intentionally Blank

Operating Instructions - Overview



General Information

Correct care of your engine will result in longer life, better performance, and more economical operation.

Follow the daily maintenance checks listed in Maintenance Guidelines (Section 2).

The new Cummins® engine associated with this manual does **not** require a "break-in" procedure. This section of the manual provides all of the necessary information required for proper engine operation.

U.S. legislation requires that stationary compression ignition internal combustion engines designated for emergency use are limited to emergency operations and required maintenance and testing.

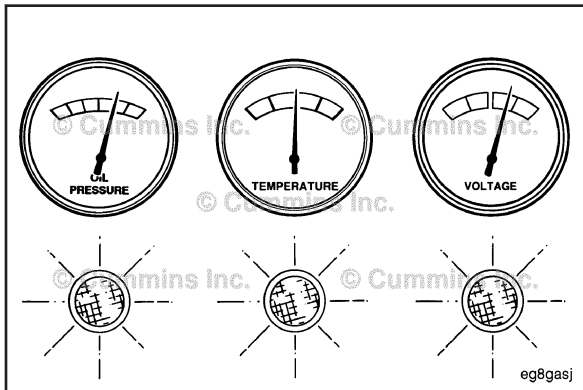

Check the oil pressure indicators, temperature indicators, warning lights, and other gauges daily to make sure they are operational.

Check the oil pressure, coolant temperatures DEF level, and other engine parameters daily via the OEM front panel to make sure they are operational. Check the panel regularly for any alarm messages. Take appropriate action to rectify the alarm condition or contact your nearest Authorized Cummins® Distributor.

⚠ WARNING ⚠

Do not operate a diesel engine where there are or can BE COMBUSTIBLE vapors. These vapors can be sucked through the air intake system and cause engine acceleration and over speeding that can result in a fire, an explosion, and extensive property damage. Numerous safety devices are available, such as air intake shutoff devices, to minimize the risk of over speeding where an engine, due to its application, is operating in a combustible environment, such as due to a fuel spill or gas leak. Remember, Cummins Inc. has no way of knowing the use you have for your engine. The equipment owner and operator ARE responsible for safe operation in a hostile environment. Consult A Cummins® Authorized Repair Location for further information.

⚠ CAUTION ⚠

Do not expose the engine to corrosive chemicals. Corrosive chemicals can damage the engine.

Cummins recommends the installation of an air intake shutoff device or a similar safety device to minimize the risk of overspeeding when an engine is operating in a combustible environment, such as due to a fuel spill or gas leak.

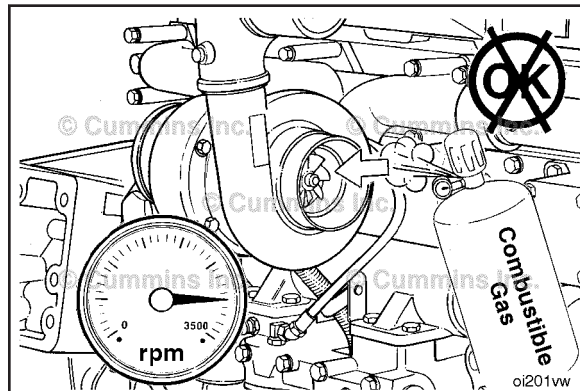

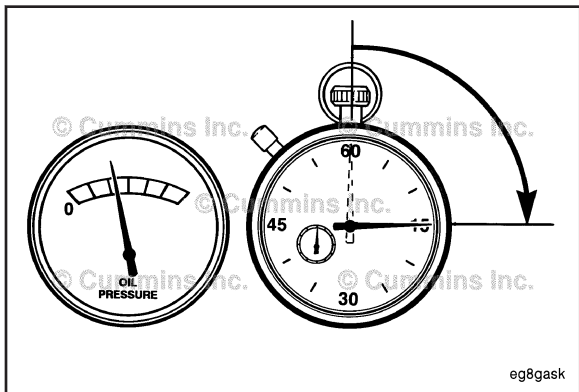

Normal Starting Procedure

General Information

⚠CAUTION⚠

The engine must have adequate oil pressure within 15 seconds after starting. If the **WARNING** lamp indicating low oil pressure has not gone out or there is no oil pressure indicated on a gauge within 15 seconds, shut off the engine immediately to avoid engine damage. The low oil pressure troubleshooting procedure is located in Troubleshooting Symptoms (Section TS).

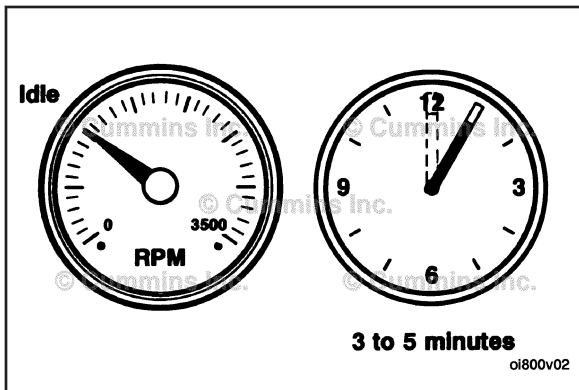

Idle the engine 3 to 5 minutes before operating with a load.

QSC8.3 and QSL9
Section 1 - Operating Instructions

Normal Starting Procedure
Page 1-5

After starting a cold engine, increase the engine speed (rpm) slowly to provide adequate lubrication to the bearings and to allow the oil pressure to stabilize.

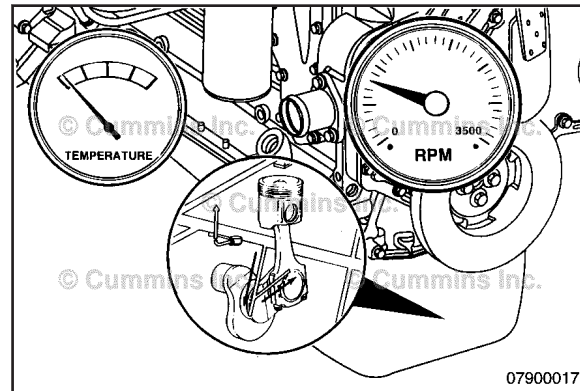

⚠ CAUTION ⚠

Do not operate engine at low idle for long periods with engine coolant temperature below the minimum specification in Maintenance Specifications (Section V). This can result in the following:

- Fuel Dilution of the lubricating oil
- Carbon build up in the cylinder
- Cylinder head valve sticking
- Reduced performance

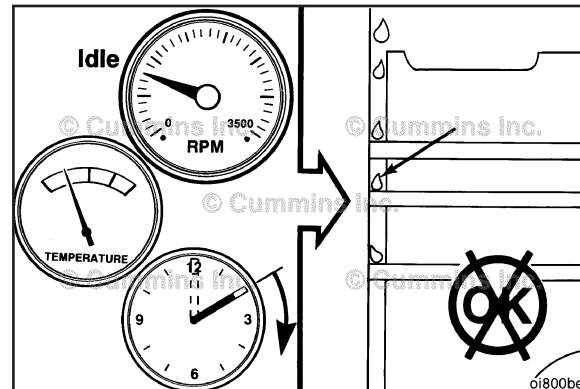

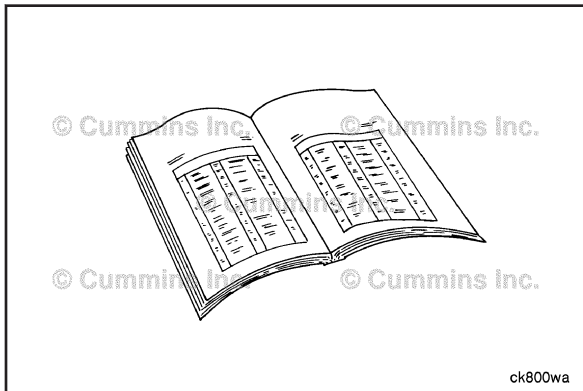

Cold Weather Starting

General Information

⚠CAUTION⚠

To reduce the possibility of damage to the lubricating oil pan, due to the composite materials used in the manufacture of the lubricating oil pan, under no circumstances should an external heat source be applied directly or indirectly to the lubricating oil pan.

Follow the Normal Starting Procedure in this section. If equipped with an intake air heater, the Wait-To-Start lamp will stay on longer.

Refer to the OEM service manual for any additional cold weather starting procedures.

Using Starting Aids



WARNING

Do not use starting fluids with this engine. This engine is equipped with an intake air heater; use of starting fluid can cause an explosion, fire, personal injury, severe damage to the engine, and property damage.

Cold weather starting aids are available for this engine. Contact a Cummins® Authorized Repair Location for more information.

Starting Procedure After Extended Shutdown or Oil Change

General Information

Follow the Normal Starting Procedure in this section. The engine will **not** start until the minimum cranking oil pressure is detected by the ECM. It can take more cranking time to start the engine after an extended shut down or oil change.

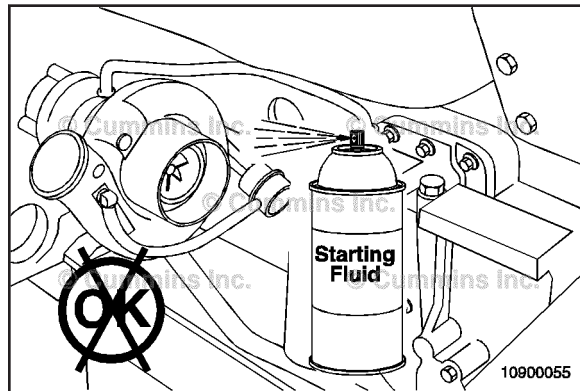

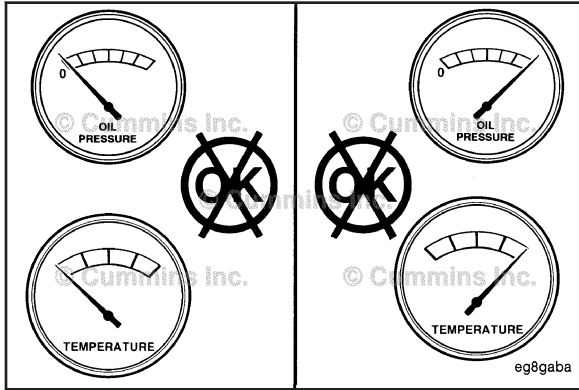

Operating the Engine Normal

If equipped, monitor the oil pressure and coolant temperature gauges frequently. Refer to Lubricating Oil System specifications and Cooling System specifications, in Maintenance Specifications (Section V) for recommended operating pressures and temperatures. Shut off the engine if any pressure or temperature does **not** meet the specifications.

Continuous operation with engine coolant temperature above or below the engine coolant temperature specifications listed in Maintenance Specifications (Section V) can damage the engine.

QSC8.3 and QSL9
Section 1 - Operating Instructions

If an overheating condition starts to occur, reduce the power output of the engine by releasing the accelerator pedal or lever or shifting the transmission to a lower gear, or both, until the temperature returns to the normal operating range. If the engine temperature does **not** return to normal, shut off the engine, and refer to Troubleshooting Symptoms (Section TS), or contact a Cummins® Authorized Repair Location.

Winterfronts and Shutters

Winterfronts and shutters can be used on a vehicle or equipment to reduce air flow through the radiator core into the engine compartment. This can reduce the time required to warm the engine and help maintain the engine coolant temperature. The engine coolant temperature specifications are in the Maintenance Specification (Section V).

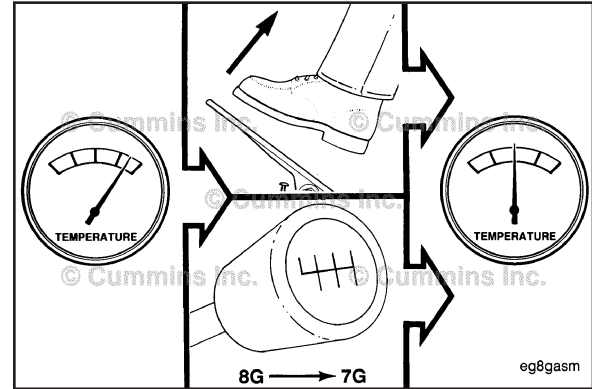

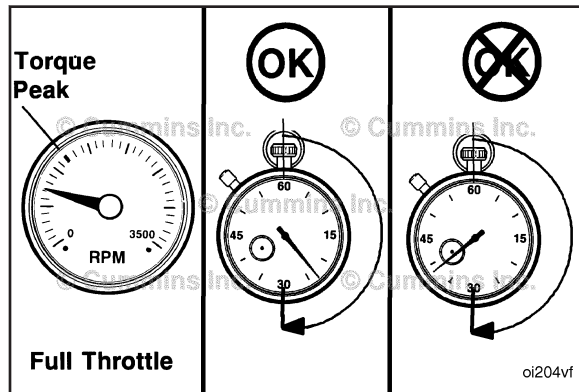

Engine Operating Range General Information

⚠CAUTION⚠

Do not operate the engine at full throttle below peak torque rpm (refer to engine dataplate for peak torque rpm) for more than 30 seconds. Operating the engine at full throttle below peak torque will shorten engine life to overhaul, can cause serious engine damage, and is considered engine abuse.

Cummins® engines are designed to operate successfully at full throttle under transient conditions down to peak torque engine speed. This is consistent with recommended operating practices.

⚠CAUTION⚠

Do not operate the engine beyond the maximum engine speed. Operating the engine beyond the maximum engine speed can cause severe engine damage. Use proper operating techniques for the vehicle, vessel, or equipment to prevent engine overspeed. The maximum engine speed specification is listed in Maintenance Specifications (Section V).

⚠ CAUTION ⚠

Do not idle the engine for excessively long periods. Long periods of idling, more than 10 minutes, can cause poor engine performance.

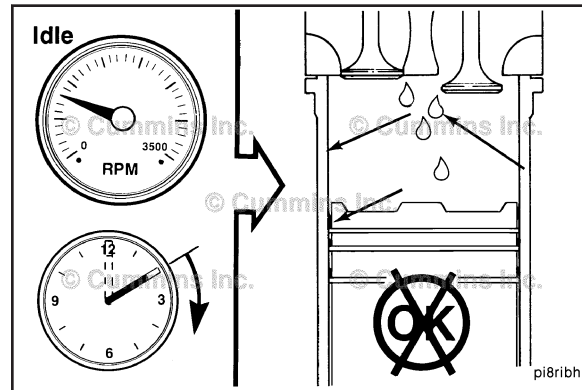

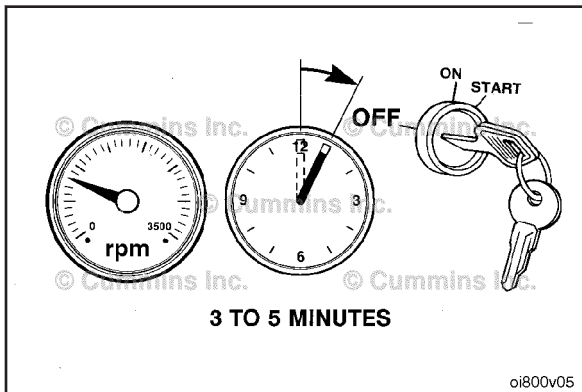

Engine Shutdown

General Information

NOTE: For engines equipped with an electronic control module (ECM) ensure the keyswitch is turned off for a minimum of 70 seconds prior to disconnecting the continuous (unswitched) battery power supply. If the unswitched battery power supply is disconnected in less than 70 seconds after the keyswitch is turned off active fault codes and incorrect ECM information can occur.

Turn the ignition switch to the OFF position. If the engine does **not** shut down, refer to Troubleshooting Symptom (Section TS) in appropriate Operation and Maintenance manual.

⚠CAUTION⚠

Failure to follow the correct shutdown procedure may result in damage to the turbocharger and shorten the turbocharger life.

Electromagnetic Interference (EMI)

General Information

Some applications utilize accessories such as (CB radios, mobile transmitters, etc.) if not installed and used correctly the radio frequency energy generated by these accessories can cause electromagnetic interference (EMI) conditions to exist between the accessory and the Cummins electronically controlled systems. Cummins is **not** liable for any

performance problems with either the electronically controlled systems or the accessory due to EMI. EMI is **not** considered by Cummins to be a system failure and therefore is **not** warrantable.

System EMI Susceptibility

Your Cummins product has been designed and tested for minimum sensitivity to incoming electromagnetic energy. Testing has shown that there is no performance degradation at relatively high energy levels; however, if very high energy levels are encountered, then some noncritical diagnostic fault code logging can occur. The electronically controlled systems EMI susceptibility level will protect your systems from most, if **not** all, electromagnetic energy-emitting devices that meet the legal requirements.

System EMI Radiation Levels

Your Cummins product has been designed to emit minimum electromagnetic energy. Electronic components are required to pass various Cummins and industry EMI specifications. Testing has shown that when the systems are properly installed, they will not interfere with onboard communication equipment or with the vehicle's, equipment's, or vessel's ability to meet any applicable EMI standards and regulated specifications.

If an interference condition is observed, follow the suggestions below to reduce the amount of interference:

- 1 Locate the transmitting antenna as far away from the electronically controlled systems and as high as possible.
- 2 Locate the transmitting antenna as far away as possible from all metal obstructions (e.g., exhaust stacks)
- 3 Consult a representative of the accessory supplier in your area to:
 - Accurately calibrate the device for proper frequency, power output, and sensitivity (both base and remote site devices **must** be properly calibrated)
 - Obtain antenna reflective energy data measurements to determine the optimum antenna location
 - Obtain optimum antenna type and mounting arrangement for your application

- Make sure your accessory equipment model is built for maximum filtering to reject incoming electromagnetic noise.

Section 2 - Maintenance Guidelines

Section Contents

	Page
Maintenance Guidelines - Overview	2-1
General Information.....	2-1
Maintenance Record Form	2-6
Maintenance Data.....	2-6
Maintenance Schedule	2-2
General Information.....	2-2
Oil Drain Intervals.....	2-4

This Page Left Intentionally Blank

Maintenance Guidelines - Overview

General Information

Cummins Inc. recommends that the system be maintained according to the Maintenance Schedule in this section.

If the system is operating in ambient temperatures below -18°C [0°F] or above 38°C [100°F], perform maintenance at shorter intervals. Shorter maintenance intervals are also required if the system is operated in a dusty environment or if frequent stops are made. For gas fueled generator sets, shorter maintenance intervals are also required, if operating at loads below 70% for prolonged periods. Contact your local Cummins® Authorized Repair Location for recommended maintenance intervals.

Some of these maintenance procedures require special tools or must be completed by qualified personnel. Contact your local Cummins® Authorized Repair Location for detailed information.

If your system is equipped with a component or accessory not manufactured or supplied by Cummins Inc., refer to the component manufacturer's maintenance recommendations.

OEM supplied equipment and components can impact on the performance and reliability of the engine if they are not correctly maintained.

Use the chart provided in this section as a convenient way to record maintenance performed.

Maintenance Schedule

General Information

Perform maintenance at whichever interval occurs first. At each scheduled maintenance interval, perform all previous maintenance checks that are due for scheduled maintenance.

Maintenance Procedures at Daily Interval

- Air Intake Piping - Check
- Cooling Fan - Check
- Crankcase Breather Tube - Check
- Air Tanks and Reservoirs - Check
- Engine Coolant Level - Check
- Fuel-Water Separator - Drain
- Engine Lubricating Oil Level - Check

Maintenance Procedures at 250 Hours or 3 Month

- Air Cleaner Restriction - Check
- Charge-Air Piping - Check
- Charge-Air Cooler - Check
- Fuel Injection Pump Mounting - Check
- Air Compressor Mounting - Check

Maintenance Procedures at 500 Hours or 6 Months

QSC8.3 and QSL9
Section 2 - Maintenance Guidelines

- Fuel Filters (Cummins® and OEM supplied) - Change
- Cooling System - Check
- Coolant Filter - Change
- Lubricating Oil Filter and Oil - Change¹
- Batteries - Check
- Battery Cables and Connections - Check
- Radiator Pressure Cap - Check

Maintenance Procedures at 1000 Hours or 1 Year

- Drive Belts - Check
- Fan Hub Belt Driven - Check
- Cooling Fan Belt Tensioner - Check

Maintenance Procedures at 2000 Hours or 2 Years

- Cooling System - Flush²
- Vibration Damper, Rubber - Check
- Vibration Damper, Viscous - Check
- Engine Steam Cleaning - Clean
- Air Compressor Discharge Lines - Clean
- Engine Mounts - Check

Maintenance Procedures at 5000 Hours or 4 Years

- Overhead Set - Adjust
- 1 The lubricating oil and lubricating oil filter interval is determined by the sulfur content of the fuel and lubricating oil type used. See the Oil Drain Intervals in this section.
 - 2 This cooling system requirement to Flush at this scheduled maintenance includes: Drain, Flush, and Fill.

Oil Drain Intervals

See Table 1 to determine the maximum recommended oil change and filter change intervals in kilometers, miles, hours, or months, whichever comes first.

Table 1					
American Petroleum Institute (API) Classification	International Classification (ACEA and JAMA)	Fuel Sulfur Content	Oil Change Interval		
			Kilometers [Miles]	Hours	Months
CJ-4 (CES 20081)	ACEA E9	< 500 ppm	14,500 [9000]	500	6
	JAMA DH-2	500 - 5000 ppm	11,600 [7200]*	400*	6
CI-4 (CES 20078)	ACEA E7	up to 5000 ppm	14,500 [9000]	500	6
API CH-4/SJ (CES 20071, 20076, or 20077)	ACEA E5	up to 5000 ppm	14,500 [9000]	500	6

Table 1					
American Petroleum Institute (API) Classification	International Classification (ACEA and JAMA)	Fuel Sulfur Content	Oil Change Interval		
			Kilometers [Miles]	Hours	Months
API CF-4/SG (CES 20075)	ACEA E3 ACEA E2 JAMA DH-1	up to 5000 ppm	7250 [4500]	250	6
API CD API CE API CG-4/SH	ACEA E1	up to 5000 ppm	Obsolete, Do Not Use		

* The oil drain interval **must** be reduced by 20 percent if American Petroleum Institute (API) CJ-4 (Cummins Inc. Engineering Standard 20081) lubricating oil is used with diesel fuel containing 0.05 to 0.5 mass percent (500 to 5000 ppm) sulfur content.

Section L - Service Literature

Section Contents

	Page
Additional Service Literature	L-1
General Information.....	L-1
Cummins Customized Parts Catalog	L-4
General Information.....	L-4
Ordering the Customized Parts Catalog.....	L-4
Ordering by Telephone.....	L-4
Ordering On-Line.....	L-5
Service Literature Ordering Location	L-3
Contact Information.....	L-3

This Page Left Intentionally Blank

Additional Service Literature

General Information

The following publications can be purchased.

Bulletin Number	Title of Publication
3666271	Troubleshooting and Repair Manual, Electronic Control System, ISC, QSC8.3, and ISL Engines
4021416	Troubleshooting and Repair Manual, ISB, ISBe2, ISBe3, ISBe4, QSB4.5, QSB5.9, QSB6.7, ISC, QSC8.3, ISL, ISLe3, ISLe4, and QSL9, CM850 Electronic Control System
4021418	Troubleshooting and Repair Manual, ISC, ISCe, QSC8.3, ISL, ISLe3, ISLe4, and QSL9 Engines
3666121	Holset® Air Compressors
4022281	SmartCraft™ Marine Control System
3666267	ISC CM554 Wiring Diagram
3666395	QSC CM554 Wiring Diagram
3666416	ISL CM554 Wiring Diagram
3666478	QSL9 CM554 Wiring Diagram
4021421	ISC and ISL CM850 Electronic Control Module Wiring Diagram
4021524	QSB4.5, QSB6.7, QSC8.3 and QSL9 CM850 Electronic Control System Wiring Diagram
4021598	ISLe4 CM850 Wiring Diagram
4081885	QSL9 and QSC8.3 Marine CM850 Electronic Control Module with SmartCraft™ 1.0 Wiring Diagram
4082045	SmartCraft™ 2.2 Zeus™ Wiring Diagram

Bulletin Number	Title of Publication
4082050	SmartCraft™ 2.2 Digital Throttle and Shift (DTS) Wiring Diagram
4082051	SmartCraft™ 2.2 Non-Digital Throttle and Shift (Non-DTS) Wiring Diagram
4082052	Asius System Wiring Diagram
4021428	Operation and Maintenance Manual, ISC, ISCe, and ISL Engines
4021518	Operation and Maintenance Manual, QSC8.3 and QSL9 Engines
4021557	Operation and Maintenance Manual, ISLe3 and ISLe4
4021571	Operation and Maintenance Manual, QSC8.3 and QSL9 Marine Engines
4081893	CMD Smartcraft™ Diesel View Configuration and Operation Manual
4081961	CMD System Speedometer and Tachometer Operation Manual
4021481	Owners Manual, QSC8.3 and QSL9 Marine Engines
4915536	Owners Manual, QSC8.3 and QSL9 Engines
3379000	Air for Your Engine
3379001	Fuel for Cummins® Engines
3379009	Operation of Diesel Engines in Cold Climates
3666132	Cummins® Coolant Requirements and Maintenance
3810303	Parts Reuse Guidelines
3810340	Cummins® Engine Oil and Oil Analysis Recommendations
3884649	Marine Recreational B and C Installation Directions
4021566	Fleetguard® Selective Catalytic Reduction - Urea Specifications

Service Literature Ordering Location Contact Information

Region

United States and Canada

All Other Countries

Ordering Location

Cummins Distributors

or

Credit Cards at 1-800-646-5609

or

Order online at www.powerstore.cummins.com

Cummins Distributors or Dealers

Cummins Customized Parts Catalog

General Information

Cummins is pleased to announce the availability of a parts catalog compiled specifically for you. Unlike the generic versions of parts catalogs that support general high volume parts content; Cummins Customized catalogs contains only the new factory parts that were used to build your engine.

The catalog cover, as well as the content, is customized with you in mind. You can use it in your shop, at your worksite, or as a coffee table book in your RV or boat. The cover contains your name, company name, address, and telephone number. Your name and engine model identification even appears on the catalog spine. Everybody will know that Cummins created a catalog specifically for you.

This new catalog was designed to provide you with the exact information you need to order parts for your engine. This will be valuable for customers that do not have easy access to the Cummins Electronic Parts Catalog or the Cummins Parts Microfilm System.

Additional Features of the Customized Catalog include:

- Engine Configuration Data
- Table of Contents
- Separate Option and Parts Indexes
- Service Kits (when applicable)
- ReCon Part Numbers (when applicable)

Ordering the Customized Parts Catalog

Ordering by Telephone

North American customers can contact their Cummins Distributor or call Gannett Direct Marketing Services at 1-800-646-5609 and order by credit card. Outside North America order on-line or make an International call to Gannett at (+)502-454-6660.

Ordering On-Line

The Customized Parts Catalog can be ordered On-Line from the Cummins Powerstore by credit card.

Contact GDMS or the CUMMINS POWERSTORE for the current price; Freight may be an additional expense.

Information we need to take your Customized Parts Catalog Order. This information drives the cover content of the CPC.

- Customer Name
- Street Address
- Company Name (optional)
- Telephone no.
- Credit Card No.
- Cummins Engine Serial Number (located on the engine data plate)
- Please identify the required media: Printed Catalog, CD-ROM, or PDF File

Unfortunately not all Cummins Engines can be supported by this parts catalog. Engines older than 1984 or newer than 3 months may not have the necessary parts information to compile a catalog. We will contact you if this occurs and explain why we are unable to fill your order.

Customized Parts Catalogs are produced specifically for a single customer. This means they are not returnable for a refund. If we make an error and your catalog is not useable, we will correct that error by sending you a new catalog.

Section V - Maintenance Specifications

Section Contents

	Page
Coolant Recommendations and Specifications	V-14
Cooling System Sealing Additives.....	V-17
Cooling System Soluble Oils.....	V-18
Fully Formulated Coolant/Antifreeze.....	V-14
Cooling System	V-3
Specifications.....	V-3
Cummins®/Fleetguard® Filter Specifications	V-4
General Information.....	V-4
Fuel Recommendations and Specifications	V-6
Fuel Recommendations.....	V-6
General Engine	V-1
Specifications.....	V-1
Lubricating Oil Recommendations and Specifications	V-8
AfterMarket Oil Additive Usage.....	V-13
General Information.....	V-8
New Engine Break-in Oils.....	V-13
Lubricating Oil System	V-2
Specifications.....	V-2

This Page Left Intentionally Blank

General Engine

Specifications

Listed below are the general specifications for this engine.

Horsepower.....	See engine dataplate
Firing Order.....	1-5-3-6-2-4
Crankshaft Rotation (viewed from front of engine).....	Clockwise

Bore and Stroke

8.3 liters.....	114 mm [4.49 in] x 135 mm [5.32 in]
8.9 liters.....	114 mm [4.49 in] x 144.5 mm [5.69 in]

Dry Weight

8.3 liters.....	694 kg [1530 lb]
8.9 liters.....	706 kg [1555 lb]

Wet Weight

8.3 liters.....	723 kg [1595 lb]
8.9 liters.....	738 kg [1625 lb]

Overhead Adjustment

Intake Valve Adjustment.....	0.305 mm [0.012 in]
Exhaust Valve Adjustment.....	0.559 mm [0.022 in]
Engine Brake Adjustment.....	2.286 mm [0.090 in]

Lubricating Oil System

Specifications

Oil Pressure

At Low Idle (minimum allowable).....	69 kPa [10 psi]
At Rated Speed (minimum allowable).....	207 kPa [30 psi]
Regulated Oil Pressure.....	517 kPa [75 psi]
Lubricating Oil Filter Capacity.....	3.78 liters [4 qt]

Oil Pan Capacity, Low to High (8.3 liter engines)

Standard Oil Pan.....	15.1 to 18.9 liters [16 to 20 qt]
Standard Oil Pan with Cylinder Block Stiffener Plate.....	16.1 to 19.9 liters [17 to 21 qt]

Total System Capacity (Oil Pan and New Oil Filter) (8.3 liter engines)

Standard Oil Pan.....	22.7 liters [24 qt]
Standard Oil Pan with Cylinder Block Stiffener Plate.....	23.7 liters [25 qt]

Oil Pan Capacity, Low to High (8.9 liter engines)

Standard Oil Pan.....	18.9 to 22.7 liters [20 to 24 qt]
Standard Oil Pan with Cylinder Block Stiffener Plate.....	19.9 to 23.7 liters [21 to 25 qt]
Large Oil Pan "Power Generation" with Cylinder Block Stiffener Plate.....	20.5 to 29.9 liters [21.1 to 31.7 qt]

Total System Capacity (Oil Pan and New Oil Filter) (8.9 liter engines)

Standard Oil Pan.....	26.5 liters [28 qt]
Standard Oil Pan With Cylinder Block Stiffener Plate.....	27.4 liters [29 qt]
Large Oil Pan "Power Generation" with Cylinder Block Stiffener Plate.....	33.7 liters [35.7 qt]

Cooling System

Specifications

Coolant Capacity (engine only).....	11.1 liters [11.7 qt]
Standard Modulating Thermostat Range.....	82 to 93°C [180 to 200°F]
Recommended Pressure Cap.....	103 kPa [15 psi]
Minimum Fill Rate (without low-level alarm).....	19 liters/min [5 gpm]
Maximum Deaeration Time.....	25 minutes
Maximum Top Tank Coolant Temperature With CAPS Fuel System.....	100°C [212°F]
Maximum Top Tank Coolant Temperature With Cummins Common Rail Fuel System.....	107°C [225°F]

Winterfronts - Automotive Only

Air Passage Area.....	774 cm ² [120 in ²]
-----------------------	--

Cummins®/Fleetguard® Filter Specifications

General Information

Cummins Filtration™ is a subsidiary of Cummins Inc. Cummins Filtration™ filters are developed through joint testing at Cummins Inc. and Cummins Filtration™. Cummins Filtration™ filters are standard on new Cummins® engines. Cummins Inc. recommends their use.

Cummins Filtration™ products meet all Cummins® Source Approval Test standards to provide the quality filtration necessary to achieve the engine's design life. If other brands are substituted, the purchaser should insist on products that the supplier has tested to meet Cummins Inc. high-quality standards.

Cummins Inc. can **not** be responsible for problems caused by non-genuine filters that do **not** meet Cummins Inc. performance or durability requirements.

Filter Part Numbers (All Applications Except Marine)				
-	Coolant Filter	Water-separating Filter	Fuel Filter	Lubricating Oil Filter
Without CM850	-	-	-	-
Cummins® Part Number	3100304 ¹ , 3098690 ²	3944269	N/A	3401544
Cummins Filtration™ Part Number	WF2071 ¹ , WF2123 ²	FS1022	N/A	LF9009
With CM850	-	-	-	-
Cummins® Part Number	3100304 ¹ , 3098690 ²	4070801	3959612	3401544

Filter Part Numbers (All Applications Except Marine)				
-	Coolant Filter	Water-separating Filter	Fuel Filter	Lubricating Oil Filter
Cummins Filtration™ Part Number	WF2071 ¹ , WF2123 ²	FS1003	FF5488	LF9009

- 1 This filter is designed for service intervals up to 40,234 km [25,000 miles] when using TMC RP329/RP330 or ASTM D6210 coolants that meet Cummins® Engineering Standard CES 14603. The filter is designed for cooling systems up to 45 liters [12 gallons]. Refer to Cummins® Coolant Requirements and Maintenance, Bulletin 3666132. If the coolant system capacity is greater than 45 liters [12 gallons], one unit of chemical per 3 system gallons is required for adequate system treatment. If needed, contact Cummins Filtration™ (Toll Free - (800) 223-4583) for other coolant filter options for different size cooling systems.
- 2 This filter has been designed for extended service intervals of 80,467 to 241,402 km [50,000 to 150,000 miles]. It has no chemical additives, as it contains zero units of DCA4. When using the WF2123 filter, the appropriate volumes of liquid treatment **must** be added at the designated distances/intervals. For a 25,000 mile service interval with RP329/RP330 coolants, one pint of DCA4 (or DCA2) liquid treatment should be added for cooling systems that do **not** exceed 45 liters [12 gallons]. For a 150,000 mile service interval with ES Compleat™ Coolant (ES Extender Liquid), one quart of this liquid treatment should be added for cooling systems that do **not** exceed 45 liters [12 gallons].

NOTE: An LF9009 lubricating oil filter **must** be used. A venturi type lubricating oil filter **must** be used in order to benefit from the bypass filtration section of the lubricating oil filter. Do **not** use an LF3000 lubricating oil filter. Engine durability will be reduced by the use of the wrong lubricating oil filter.

Fuel Recommendations and Specifications

Fuel Recommendations



Do not mix gasoline, alcohol, or gasohol with diesel fuel. This mixture can cause an explosion.



Due to the precise tolerances of diesel injection systems, it is extremely important that the fuel be kept clean and free of dirt or water. Dirt or water in the system can cause severe damage to both the fuel pump and the fuel injectors.

Cummins Inc. recommends the use of ASTM number 2D fuel. The use of number 2 diesel fuel will result in optimum engine performance.

At operating temperatures below 0°C [32°F], acceptable performance can be obtained by using blends of number 2D and number 1D.

NOTE: Lighter fuels can reduce fuel economy.

NOTE: Engines equipped with diesel particulate filters require the use of diesel fuel with 30 ppm sulfur maximum. There are no acceptable substitutes.

The viscosity of the fuel **must** be kept above 1.3 cSt at 40°C [104°F] to provide adequate pumping and lubricating characteristics to fuel system components.

The following chart lists acceptable substitute fuels for this engine.

Acceptable Substitute Fuels									
Number 1D Diesel ⁽¹⁾ (2) (3)	Number 2D Diesel ⁽³⁾	Number 1K Kerosene	Jet-A	Jet-A1	JP-5	JP-8	Jet-B	JP-4	CITE
A	OK	Not OK	A	A	A	A	Not OK	Not OK	Not OK
An "A" means OK only if fuel lubricity is adequate. This means the BOCLE number is 3100 or greater as measured by ASTM specification D6078, Scuffing Load Ball On Cylinder Evaluator (SLBOCLE). Lubricity can also be measured by ASTM, specification D6079, ISO 12156, High Frequency Reciprocating Rig (HFRR) in which the fuel must have a wear scar diameter of 0.45 mm [0.02 in] or less.									
Any adjustment to compensate for reduced performance with a fuel system using alternate fuel is not warrantable.									
Winter blend fuels, such as found at commercial fuel-dispensing outlets, are combinations of number 1D and 2D diesel fuels and are acceptable.									

Additional information for fuel recommendations and specifications can be found in Fuel for Cummins Engines, Bulletin 3379001. See ordering information in the back of this manual.

Lubricating Oil Recommendations and Specifications

General Information



Extending the oil and filter change interval beyond the recommendations will decrease the engine life due to factors such as corrosion, deposits, and wear.



A sulfated ash limit of 1.85 percent has been placed on all engine lubricating oils recommended for use in Cummins engines. Higher ash oils can cause valve and/or piston damage and lead to excessive oil consumption.

The use of quality engine lubricating oils, combined with appropriate oil drain and filter change intervals, is a critical factor in maintaining engine performance and durability. Extending the oil and filter change interval beyond the recommendations will decrease engine life due to factors such as corrosion, deposits, and wear. Reference Procedure 102-002 in Section 2 to determine which oil drain interval to use for the application.

Cummins Inc. recommends the use of high-quality SAE 15W-40 heavy-duty engine oil, such as Valvoline® Premium Blue® (USA) or Valvoline Premium Blue Extra (International).

NOTE: The responsibility is with the owner. If recommendations are ignored, warranty could be affected.

API: American Petroleum Institute

CES: Cummins® Engineering Standard

ACEA - Association des Constructeurs Europeen d' Association

JAMA - Japanese Automobile Manufacturers Association

Table 1: Cummins® Engineering Standards (CES) for Lubricants			
Cummins Engineering Standard Classification (CES)	North American Classification	International Classifications	Comments
Obsolete. Do not use.	API CD API CE	ACEA E-1	Obsolete. Do not use.
	API CG-4/SH		
CES-20075 ¹	API CF-4/SG	ACEA E-2	Minimum acceptable oil classification for MidRange engines, but is not recommended.
		ACEA E-3	
		JAMA DH-1	
CES-20071 ²	API CH-4 4/SJ	ACEA E5	Acceptable oil classification for MidRange engines.
CES-20076 ²			
CES-20077 ²			
CES-20078	API CI-4	ACEA E7	Excellent oil for MidRange engines.
CES-20081	API1 CJ-4	ACEA E9	Excellent oil for MidRange engines where ultra-low sulfur diesel fuel is used. ³
		JAMA DH-2	

Table Notes

- For MidRange engines, in areas where CH-4/SJ or CG-4/SH oils are **not** available, refer to the oil drain intervals in Section 2. As an alternative, oils meeting CES-20075 can be used, but the oil drain interval and filter change interval **must** be reduced by half.

- 2 Outside North America, where oil meeting CES-20071, CES-20076, or CES20077 might **not** be available, Cummins Inc. primary recommendation is for an oil meeting Global DHD-1, as jointly developed by EMA, ACEA, and JAMA.
- 3 Ultra-low sulfur diesel fuel is defined as diesel fuel **not** exceeding 0.0015 (15 ppm) mass percent sulfur content (ultra-low diesel fuel is also defined by ASTM S-15).

A sulfated ash limit of 1.0 mass percent is suggested for optimum valve and piston deposit and oil consumption control.

For further details and discussion of engine lubricating oils for Cummins engines, refer to Cummins Engine Oil Recommendations, Bulletin 3810340.



The API service symbols are shown in the accompanying illustration. The upper half of the symbols display the appropriate oil categories.

The lower half can contain words to describe oil energy-conserving features.

The center section identifies the SAE oil viscosity grade.

QSC8.3 and QSL9 Section V - Maintenance Specifications

As the engine oil becomes contaminated, essential oil additives are depleted. Lubricating oils protect the engine as long as these additives are functioning properly. Progressive contamination of the oil between oil and filter change intervals is normal. The amount of contamination will vary, depending on the operation of the engine, kilometers or miles on the oil, fuel consumed, and new oil added.

Extending oil and filter change intervals beyond the recommendations will decrease engine life due to factors such as corrosion, deposits, and wear.

Reference the oil drain chart in this section to determine which oil drain interval to use for your application.

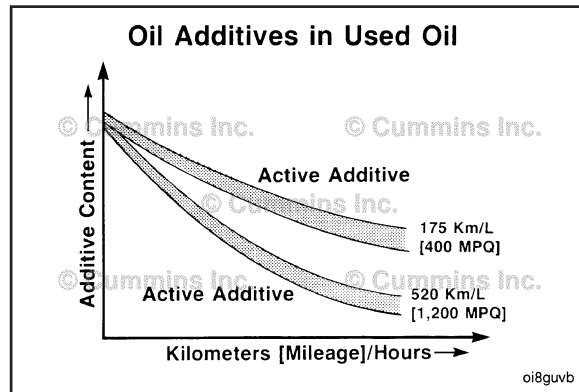

The primary Cummins Inc. recommendation is for the use of 15W-40 multigrade lubricating oil for normal operation at ambient temperatures above -15°C [5°F]. The use of multigrade oil reduces deposit formation, improves engine cranking in low temperature conditions, and increases engine durability by maintaining lubrication during high temperature operating conditions. Since multigrade oils have been shown to provide approximately 30 percent lower oil consumption compared with monograde oils, it is important to use multigrade oils to be certain the engine will meet applicable emissions requirements.

Use of "synthetic engine oils" (those made with API group 3 or group 4 base stocks) is permitted, subject to the same performance and viscosity limitations of petroleum (mineral) based engine oils. The same oil change intervals that are applied to petroleum (mineral) based engine oils **must** be applied to synthetic oils.

For further details and discussion of engine lubricating oils for Cummins® engines, refer to the latest revision of Cummins® Engine Oil Recommendations, Bulletin 3810340.

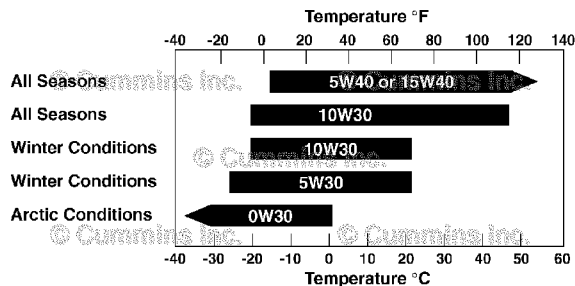

While the preferred viscosity grade is 15W-40, lower viscosity multigrade oils can be used in colder climates. See the accompanying chart. Any viscosity grade lower than 15W-40 must still meet CES 20081.

Synthetic engine oils, API Group III and Group IV basestocks, are recommended for use in Cummins® engines operating in ambient temperature conditions consistently below -25°C [-13°F]. Synthetic 0W-30 oils that meet the requirements of API Group III or Group IV basestocks, can be used in operations where the ambient temperature never exceeds 0°C [32°F]. Multiviscosity oils rated 0W-30 do **not** offer the same level of protection against fuel dilution as do higher multigrade oils. Higher cylinder wear can be experienced when using 0W-30 oils in high-load situations.

As these oils have directionally thinner oil films than 15W-40 oils, top-quality Fleetguard® filters **must** be used above 20°C [70°F]. Some oil suppliers might claim better fuel economy for these oils. Cummins Inc. can neither approve nor disapprove any product **not** manufactured by Cummins Inc. These claims are between the customer and the oil supplier. Obtain a commitment from the oil supplier that the oil will give satisfactory performance in Cummins® engines, or do **not** use the oil.

New Engine Break-in Oils

Special “break-in” engine lubricating oils are **not** recommended for new or rebuilt Cummins® engines. Use the same type of oil during the break-in as is used in normal operation.

AfterMarket Oil Additive Usage

Cummins Inc. does **not** recommend the use of aftertreatment oil additives. Present high-quality fully additive engine lubricating oils are very sophisticated, with precise amounts of additives blended into the lubricating oil to meet stringent requirements. These oils meet performance characteristics that conform to the lubricant industry standards. Aftermarket lubricating oil additives are **not** necessary to enhance engine oil performance, and in some cases, can reduce the finished oil's ability to protect the engine.

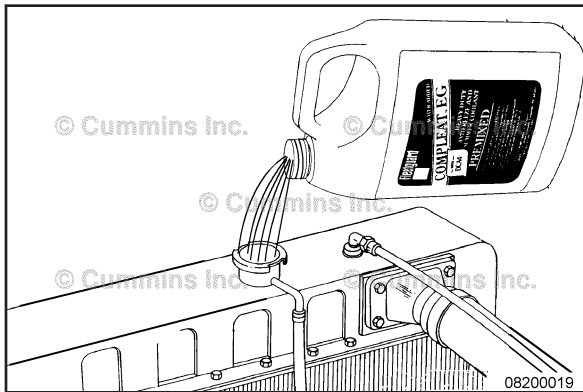

Coolant Recommendations and Specifications

Fully Formulated Coolant/Antifreeze

Cummins Inc. recommends the use of fully formulated antifreeze/coolant meeting Cummins® Engineering Standard (C.E.S.) 14603. For further details and discussion of coolant for Cummins® engines, refer to Coolant Requirements and Maintenance, Bulletin 3666132.

Cummins Inc. recommends using either a 50/50 mixture of good-quality water and fully formulated antifreeze, or fully formulated coolant when filling the cooling system.

Good-quality water is important for cooling system performance. Excessive levels of calcium and magnesium contribute to scaling problems, and excessive levels of chlorides and sulfates cause cooling system corrosion.

Water Quality	
Calcium Magnesium (hardness)	Maximum 170 ppm as (CaCO₃ + MgCO₃)
Chloride	40 ppm as (Cl)
Sulfur	100 ppm as (SO ₄)

QSC8.3 and QSL9 Section V - Maintenance Specifications

Cummins Inc. recommends Cummins Filtration™ antifreeze coolants including Compleat ES™ containing DCA4 Plus, Fleetcool™ EX containing DCA2 Plus, and ES Optimax™ Organic Acid Technology (OAT), which meet the requirements of Cummins® Engineering Standard 14603. However, Cummins Inc., Chevron Corporation and Shell have agreed that Chevron Texaco™, Shell Rotella™ and their private label counterpart Extended Life OAT coolants, which do **not** meet the elastomer compatibility section of Cummins® Engineering Standard 14603, are acceptable for extended service interval use, assuming the initial coolant fill requirements were met from the vehicle's original equipment manufacturer (OEM).

MidRange, Heavy Duty and High Horsepower engine overhauls, or repairs involving the replacement of the following components, using this Extended Life OAT coolant, **must** discard the coolant and replace it with new coolant.

- Rocker lever housing gasket
- Lubricating oil cooler housing gasket
- Cylinder head gasket
- Thermostat housing gasket

If the replacement coolant is Chevron Texaco™, Shell Rotella™ or their private label counterpart Extended Life OAT coolants, which do **not** meet the elastomer compatibility section of Cummins® Engineering Standard 14603, the coolant **must** be treated by adding 0.24 liters [8 oz] of liquid silicate fluid for every 45.5 liters [12 gal] of total coolant system volume. It is critical to **not** overtreat the coolant with silicate fluid.

To obtain order forms or ask questions relative to ordering the silicate fluid, contact:

- Silicate Fluid Order Program
- P.O. Box 27388
- Houston, TX
- 77277-7388
- Phone: 800-346-9041
- Fax: 800-876-5317

For further details and discussion of engine coolant for Cummins® engines, refer to Cummins® Coolant Requirements and Maintenance, Bulletin 3666132.

Coolant Recommendations and Specifications Page V-15



oi805vn

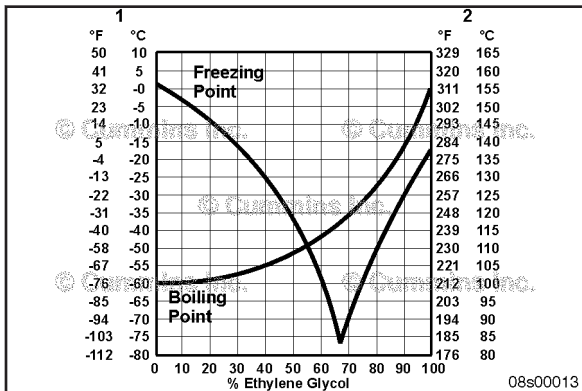

Fully formulated antifreeze **must** be mixed with good-quality water at a 50/50 ratio (40- to 60-percent working range). A 50/50 mixture of antifreeze and water gives a -36°C [-33°F] freezing point and a 108°C [226°F] boiling point, which is adequate for locations in North America. The actual lowest freezing point of ethylene glycol antifreeze is at 68 percent. Using higher concentrations of antifreeze will raise the freezing point of the solution and increase the possibility of a silica gel problem.

Legend

- 1 Freezing Point Temperature Scale
- 2 Boiling Point Temperature Scale



A refractometer **must** be used to measure the freezing point of the coolant accurately. Use Cummins Filtration™ refractometer, Part Number CC2800 or CC2806.

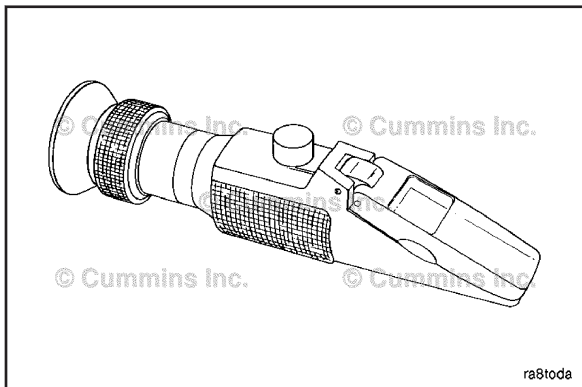

QSC8.3 and QSL9
Section V - Maintenance Specifications

Do **not** use a floating ball hydrometer. Floating ball hydrometers can give incorrect readings.

Cooling System Sealing Additives

Do **not** use sealing additives in the cooling system. The use of sealing additives will:

- Build up in coolant low-flow areas
- Plug the radiator and oil cooler
- Possibly damage the water pump seal.

Coolant Recommendations and Specifications
Page V-17

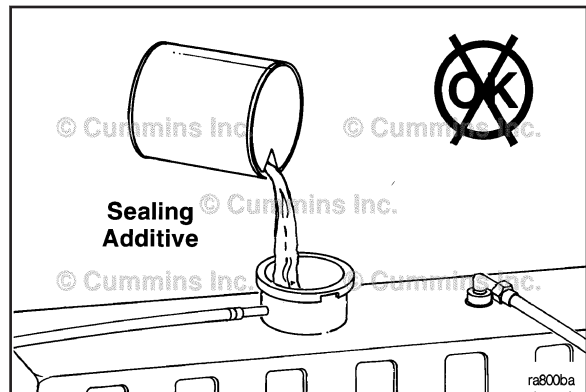
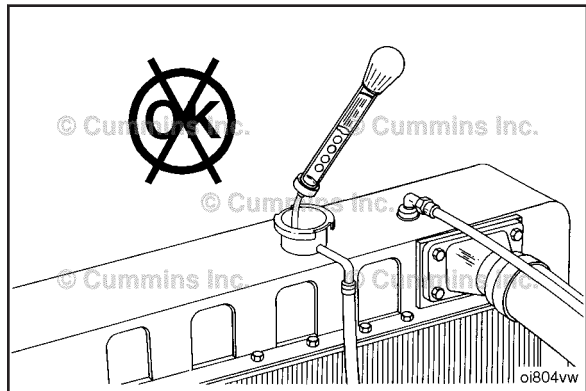

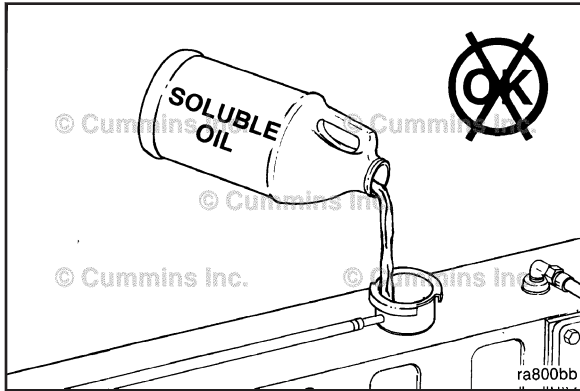

Cooling System Soluble Oils

Do **not** use soluble oils in the cooling system. The use of soluble oils will:

- Corrode brass and copper
- Damage heat transfer surfaces
- Damage seals and hoses.

Section W - Warranty

Section Contents

	Page
California Emission Control System Warranty, Off-Highway	W-21
Owner's Warranty Responsibilities	W-23
.....	W-22
All Engines International Industrial (Off-Highway)	W-8
All Engines United States And Canada Industrial (Off-Highway)	W-1
CMD Quantum Commercial Marine Propulsion (QSB5.9/QSB6.7/QSC8.3/QSL9/QSM11/SDI/TDI)	W-13

This Page Left Intentionally Blank

All Engines United States And Canada Industrial (Off-Highway) Coverage

Products Warranted

This Warranty applies to new Engines sold by Cummins and delivered to the first user on or after April 1, 1999, that are used in Industrial (Off-Highway) applications in the United States* and Canada, except for Engines used in marine, generator drive and certain defense applications, for which different Warranty Coverage is provided.

Base Engine Warranty

This Warranty covers any failures of the Engine, under normal use and service, which result from a defect in material or factory workmanship (Warrantable Failures).

Coverage begins with the sale of the Engine by Cummins. Coverage continues for two years or 2,000 hours of operation, whichever occurs first, from the date of delivery of the Engine to the first user, or from the date the unit is first leased, rented or loaned, or when the Engine has been operated for 50 hours, whichever occurs first. If the 2,000 hour limit is exceeded during the first year, Coverage continues until the end of the first year.

Engine aftertreatment components included in the Cummins Critical Parts List (CPL) and marked with a Cummins part number are covered under Base Engine Warranty.

Additional Coverage is outlined in the Emission Warranty section.

Extended Major Components Warranty

The Extended Major Components Warranty covers Warrantable Failures of the Engine cylinder block, camshaft, crankshaft and connecting rods (Covered Parts).

Bushing and bearing failures are not covered.

This Coverage begins with the expiration of the Base Engine Warranty and ends three years or 10,000 (3,000 hours for A Series Engines) hours of operation from the date of delivery of the Engine to the first user, or from the date the unit is first leased, rented or loaned, or from when the Engine has been operated for 50 hours, whichever occurs first.

Consumer Products

The Warranty on Consumer Products in the United States* is a LIMITED Warranty. **CUMMINS IS NOT RESPONSIBLE FOR INCIDENTAL OR CONSEQUENTIAL DAMAGES.** Any implied Warranties applicable to Consumer Products in the United States* terminate concurrently with the expiration of the express Warranties applicable to the product. In the United States*, some states do not allow the exclusion of incidental or consequential damages, or limitations on how long an implied Warranty lasts, so the limitations or exclusions herein may not apply to you.

These Warranties are made to all Owners in the chain of distribution and Coverage continues to all subsequent Owners until the end of the periods of Coverage.

Cummins Responsibilities

During The Base Engine Warranty

Cummins will pay for all parts and labor needed to repair the damage to the Engine resulting from a Warrantable Failure.

Cummins will pay for the lubricating oil, antifreeze, filter elements and other maintenance items that are not reusable due to the Warrantable Failure.

Cummins will pay reasonable costs for mechanics to travel to and from the equipment site, including meals, mileage and lodging, when the repair is performed at the site of the failure.

Cummins will pay reasonable labor costs for Engine removal and reinstallation when necessary to repair a Warrantable Failure.

During The Extended Major Components Warranty

Cummins will pay for the repair or, at its option, replacement of the defective Covered Part and any Covered Part damaged by a Warrantable Failure of the defective Covered Part.

Owner Responsibilities

During The Base Engine Warranty

Owner is responsible for the cost of lubricating oil, antifreeze, filter elements and other maintenance items provided during Warranty repairs unless such items are not reusable due to the Warrantable Failure.

During The Extended Major Components Warranty

Owner is responsible for the cost of all labor needed to repair the Engine, including the labor to remove and reinstall the Engine. When Cummins elects to repair a part instead of replacing it, Owner is not responsible for the labor needed to repair the part.

Owner is responsible for the cost of all parts required for the repair except for the defective Covered Part and any Covered Part damaged by a Warrantable Failure of the defective Covered Part.

Owner is responsible for the cost of lubricating oil, antifreeze, filter elements and other maintenance items replaced during repair of a Warrantable Failure.

During The Base Engine And Extended Major Components Warranties

Owner is responsible for the operation and maintenance of the Engine as specified in the applicable Cummins Operation and Maintenance Manual. Owner is also responsible for providing proof that all recommended maintenance has been performed.

Before the expiration of the applicable Warranty, Owner must notify a Cummins distributor, authorized dealer or other repair location approved by Cummins of any Warrantable Failure and make the Engine available for repair by such facility. Service locations are listed on the Cummins Worldwide Service Locator at cummins.com.

Owner is responsible for communication expenses, meals, lodging and similar costs incurred as a result of a Warrantable Failure.

Owner is responsible for non-Engine repairs, "downtime" expenses, cargo damage, fines, all applicable taxes, all business costs and other losses resulting from a Warrantable Failure.

Limitations

Engines with an emissions certification listed below must be operated using only diesel fuel having no more than the corresponding maximum sulfur content. Failure to use the specified fuel as listed in the Cummins Fuel Bulletin

#3379001 Table 1 (Cummins Inc. Required Diesel Fuel Specifications) can damage the Engine and aftertreatment system within a short period of time. This damage could cause the Engine to become inoperable and failures attributable to the use of incorrect fuels will be denied Warranty Coverage. Fuel specifications also need to comply with local fuel regulations (EN590 for Europe and ASTM D975 for North America) for Warranty eligibility.

Maximum sulfur levels by emissions certification level as listed on the Engine's dataplate are:

EPA 2007/2010/2013	max. 15 parts per million
EPA Tier 4 Interim / Final	max. 15 parts per million
EU Stage IIIB 2011	max. 15 parts per million
Euro 4/5	max. 50 parts per million
Euro 6	max. 10 parts per million

Cummins is not responsible for failures or damage resulting from what Cummins determines to be abuse or neglect, including, but not limited to: operation without adequate coolants or lubricants; overfueling; overspeeding; lack of maintenance of lubricating, cooling or intake systems; improper storage, starting, warm-up, run-in or shutdown practices; unauthorized modifications of the Engine. Cummins is also not responsible for failures caused by incorrect oil, fuel or diesel exhaust fluid or by water, dirt or other contaminants in the fuel, oil or diesel exhaust fluid.

For power units and fire pumps (package units), this Warranty applies to accessories, except for clutches and filters, supplied by Cummins which bear the name of another company.

For all other Industrial engines (except those previously mentioned), this Warranty does not apply to accessories which bear the name of another company. Such non-warranted accessories include, but are not limited to: alternators, starters, fans**, air conditioning compressors, clutches, filters, transmissions, torque converters, steering pumps, and non-Cummins fan drives, Engine compression brakes and air compressors.

Cummins Compusave units are covered by a separate Warranty.

Before a claim for excessive oil consumption will be considered, Owner must submit adequate documentation to show that consumption exceeds Cummins published standards.

Failures of belts and hoses supplied by Cummins are not covered beyond the first 500 hours or one year of operation, whichever occurs first.

Parts used to repair a Warrantable Failure may be new Cummins parts, Cummins approved rebuilt parts or repaired parts. Cummins is not responsible for failures resulting from the use of parts not approved by Cummins.

A new Cummins or Cummins approved rebuilt part used to repair a Warrantable Failure assumes the identity of the part it replaced and is entitled to the remaining Coverage hereunder.

For all A Series Applications, including Industrial, travel reimbursement for non-transportable equipment will be limited to 4.0 hours, \$0.25/mile and 250 miles maximum. Any costs beyond this limit are the customer's responsibility.

CUMMINS DOES NOT COVER WEAR OR WEAROUT OF COVERED PARTS.

CUMMINS IS NOT RESPONSIBLE FOR INCIDENTAL OR CONSEQUENTIAL DAMAGES.

THESE WARRANTIES SET FORTH HEREIN ARE THE SOLE WARRANTIES MADE BY CUMMINS IN REGARD TO THESE ENGINES. CUMMINS MAKES NO OTHER WARRANTIES, EXPRESS OR IMPLIED, OR OF MERCHANTABILITY OR FITNESS FOR A PARTICULAR PURPOSE.

This Warranty gives you specific legal rights, and you may also have other rights which vary from state to state.

Emission Warranty

Products Warranted

This Emission Warranty applies to new Engines marketed by Cummins that are used in the United States* and Canada in vehicles designed for Industrial Off-Highway use. This Warranty applies to Engines delivered to the ultimate purchaser on or after April 1, 1999, for Engines up to 750 horsepower and on or after January 1, 2000, for Engines 751 horsepower and over.

Coverage

Cummins warrants to the ultimate purchaser and each subsequent purchaser that the Engine is designed, built and equipped so as to conform at the time of sale by Cummins with all U.S. Federal emission regulations applicable at the time of manufacture and that it is free from defects in workmanship or material which would cause it not to meet these regulations within the longer of the following periods: (A) ***Five years or 3,000 hours of operation for industrial applications, five years or 3,500 hours of operation for industrial spark-ignited Engines (GTA855, G855, G5.9C, G8.3-C, GTA8.9E, QSK19G) and five years or 2,500 hours of operation for industrial spark-ignited Engines (GKTA19-GC), whichever occurs first, as measured from the date of delivery of the Engine to the ultimate purchaser, or (B) The Base Engine Warranty.

If the vehicle in which the Engine is installed is registered in the state of California, a separate California Emission Warranty also applies.

Limitations

Engines with an emissions certification listed below must be operated using only diesel fuel having no more than the corresponding maximum sulfur content. Failure to use the specified fuel as listed in the Cummins Fuel Bulletin #3379001 Table 1 (Cummins Inc. Required Diesel Fuel Specifications) can damage the Engine and aftertreatment system within a short period of time. This damage could cause the Engine to become inoperable and failures attributable to the use of incorrect fuels will be denied Warranty Coverage. Fuel specifications also need to comply with local fuel regulations (EN590 for Europe and ASTM D975 for North America) for Warranty eligibility.

Maximum sulfur levels by emissions certification level as listed on the Engine's dataplate are:

EPA 2007/2010/2013	max. 15 parts per million
EPA Tier 4 Interim / Final	max. 15 parts per million
EU Stage IIIB 2011	max. 15 parts per million
Euro 4/5	max. 50 parts per million
Euro 6	max. 10 parts per million

Failures, other than those resulting from defects in materials or workmanship, are not covered by this Warranty.

Cummins is not responsible for failures or damage resulting from what Cummins determines to be abuse or neglect, including, but not limited to: operation without adequate coolant or lubricants; overfueling; overspeeding; lack of maintenance of lubricating, cooling or intake systems; improper storage, starting, warm-up, run-in or shutdown practices; unauthorized modifications of the Engine. Cummins is also not responsible for failures caused by incorrect oil, fuel or diesel exhaust fluid or by water, dirt or other contaminants in the fuel, oil or diesel exhaust fluid.

Cummins is not responsible for non-Engine repairs, "downtime" expenses, cargo damage, fines, all business costs or other losses resulting from a Warrantable Failure.

CUMMINS IS NOT RESPONSIBLE FOR INCIDENTAL OR CONSEQUENTIAL DAMAGES.

* United States includes American Samoa, the Commonwealth of Northern Mariana Islands, Guam, Puerto Rico and the U.S. Virgin Islands.

** Alternators, starters, and fans ARE covered for the duration of the Base Engine Warranty on A Series and B3.3 Engines.

** Alternators and starters are covered for the duration of the Base Engine Warranty on QSK23 Engines.

*** Emissions Warranty for BLPG Industrial Off-Highway Engines is 5 years / 3,500 hours.

All Engines International Industrial (Off-Highway) Coverage

Products Warranted

This Warranty applies to new Engines sold by Cummins and delivered to the first user on or after April 1, 1999, that are used in Industrial (Off-Highway) applications anywhere in the world where Cummins approved service is available, except the United States and Canada. Different Warranty Coverage is provided for Engines used in marine, generator drive and certain defense applications.

Base Engine Warranty

This Warranty covers any failures of the Engine, under normal use and service, which result from a defect in material or factory workmanship (Warrantable Failure).

Coverage begins with the sale of the Engine by Cummins. Coverage continues for two years or 2,000 hours of operation, whichever occurs first, from the date of delivery of the Engine to the first user, or from the date the unit is first leased, rented or loaned, or when the Engine has been operated for 50 hours, whichever occurs first. If the 2,000 hour limit is exceeded during the first year, Coverage continues until the end of the first year.

Engine aftertreatment components included in the Cummins Critical Parts List (CPL) and marked with a Cummins part number are covered under Base Engine Warranty.

Extended Major Components Warranty

The Extended Major Components Warranty covers Warrantable Failures of the Engine cylinder block, camshaft, crankshaft and connecting rods (Covered Parts).

Bushing and bearing failures are not covered.

This Coverage begins with the expiration of the Base Engine Warranty and ends three years or 10,000 hours (3,000 hours for A Series Engines) of operation, from the date of delivery of the Engine to the first user, or from the date the unit is first leased, rented or loaned, or when the Engine has been operated for 50 hours, whichever occurs first.

These Warranties are made to all Owners in the chain of distribution, and Coverage continues to all subsequent Owners until the end of the periods of Coverage.

Cummins Responsibilities

During The Base Engine Warranty

Cummins will pay for all parts and labor needed to repair the damage to the Engine resulting from a Warrantable Failure.

Cummins will pay for the lubricating oil, antifreeze, filter elements and other maintenance items that are not reusable due to a Warrantable Failure.

Cummins will pay reasonable costs for mechanics to travel to and from the equipment site, including meals, mileage and lodging, when the repair is performed at the site of the failure.

Cummins will pay reasonable labor costs for Engine removal and reinstallation when necessary to repair a Warrantable Failure.

During The Extended Major Components Warranty

Cummins will pay for the repair or, at its option, replacement of the defective Covered Part and any Covered Part damaged by a Warrantable Failure of the defective Covered Part.

Owner Responsibilities

During The Base Engine Warranty

Owner is responsible for the cost of lubricating oil, antifreeze, filter elements and other maintenance items replaced during Warranty repairs unless such items are not reusable due to the Warrantable Failure.

During The Extended Major Components Warranty

Owner is responsible for the cost of all labor needed to repair the Engine, including the labor to remove and reinstall the Engine. When Cummins elects to repair a part instead of replacing it, Owner is not responsible for the labor needed to repair the part.

Owner is responsible for the cost of all parts required for the repair except for the defective Covered Part and any Covered Part damaged by a Warrantable Failure of the defective Covered Part.

Owner is responsible for the cost of lubricating oil, antifreeze, filter elements and other maintenance items replaced during repair of a Warrantable Failure.

During The Base Engine Warranty And Extended Major Components Warranties

Owner is responsible for the operation and maintenance of the Engine as specified in the applicable Cummins Operation and Maintenance Manual. Owner is also responsible for providing proof that all recommended maintenance has been performed.

Before the expiration of the applicable Warranty, Owner must notify a Cummins distributor, authorized dealer or other repair location approved by Cummins of any Warrantable Failure and make the product available for repair by such facility. Service locations are listed in the Cummins Worldwide Service Locator at cummins.com.

Owner is responsible for communication expenses, meals, lodging and similar costs incurred as a result of a Warrantable Failure.

Owner is responsible for non-Engine repairs, "downtime" expenses, cargo damage, fines, all applicable taxes, all business costs and other losses resulting from a Warrantable Failure.

Limitations

Engines with an emissions certification listed below must be operated using only diesel fuel having no more than the corresponding maximum sulfur content. Failure to use the specified fuel as listed in the Cummins Fuel Bulletin #3379001 Table 1 (Cummins Inc. Required Diesel Fuel Specifications) can damage the Engine and aftertreatment system within a short period of time. This damage could cause the Engine to become inoperable and failures attributable to the use of incorrect fuels will be denied Warranty Coverage. Fuel specifications also need to comply with local fuel regulations (EN590 for Europe and ASTM D975 for North America) for Warranty eligibility.

Maximum sulfur levels by emissions certification level as listed on the Engine's dataplate are:

EPA 2007/2010/2013	max. 15 parts per million
EPA Tier 4 Interim / Final	max. 15 parts per million
EU Stage IIIB 2011	max. 15 parts per million
Euro 4/5	max. 50 parts per million
Euro 6	max. 10 parts per million

Cummins is not responsible for failures or damage resulting from what Cummins determines to be abuse or neglect, including, but not limited to: operation without adequate coolants or lubricants; overfueling; overspeeding; lack of maintenance of lubricating, cooling or intake systems; improper storage, starting, warm-up, run-in or shutdown practices; unauthorized modifications of the Engine. Cummins is also not responsible for failures caused by incorrect oil, fuel or diesel exhaust fluid or by water, dirt or other contaminants in the fuel, oil or diesel exhaust fluid.

For power units and fire pumps (package units) the Warranty applies to accessories, except for clutches and filters supplied by Cummins which bear the name of another company.

Except for the accessories noted previously, Cummins does not warrant accessories which bear the name of another company. Such non-warranted accessories include, but are not limited to: alternators, starters, fans*, air conditioning compressors, clutches, filters, transmissions, torque converters, steering pumps, non-Cummins fan drives and air cleaners.

Cummins Compusave units are covered by a separate Warranty.

Before a claim for excessive oil consumption will be considered, Owner must submit adequate documentation to show that consumption exceeds Cummins published standards.

Failures of belts and hoses supplied by Cummins are not covered beyond the first 500 hours or one year of operation, whichever occurs first.

Parts used to repair a Warrantable Failure may be new Cummins parts, Cummins approved rebuilt parts or repaired parts. Cummins is not responsible for failures resulting from the use of parts not approved by Cummins.

A new Cummins or Cummins approved rebuilt part used to repair a Warrantable Failure assumes the identity of the part it replaced and is entitled to the remaining Coverage hereunder.

For all A Series Applications, including Industrial, travel reimbursement for non-transportable equipment will be limited to 4.0 hours, \$0.25/mile and 250 miles maximum. Any costs beyond this limit are the customer's responsibility.

CUMMINS DOES NOT COVER WEAR OR WEAROUT OF COVERED PARTS.

CUMMINS IS NOT RESPONSIBLE FOR INCIDENTAL OR CONSEQUENTIAL DAMAGES.

THESE WARRANTIES SET FORTH HEREIN ARE THE SOLE WARRANTIES MADE BY CUMMINS IN REGARD TO THESE ENGINES. CUMMINS MAKES NO OTHER WARRANTIES, EXPRESS OR IMPLIED, OR OF MERCHANTABILITY OR FITNESS FOR A PARTICULAR PURPOSE.

In the case of consumer sales, in some countries, the Owner has statutory rights which cannot be affected or limited by the terms of this Warranty.

Nothing in this Warranty excludes or restricts any contractual rights the Owner may have against third parties.

* Alternators, starters, and fans ARE covered for the duration of the Base Engine Warranty on A Series and B3.3 Engines.

* Alternators and starters are covered for the duration of the Base Engine Warranty on QSK23 Engines.

CMD Quantum Commercial Marine Propulsion (QSB5.9/QSB6.7/QSC8.3/QSL9/ QSM11/SDI/TDI)

Coverage

Engines Included in this Coverage

Marine Propulsion

QSB5.9/QSB6.7/QSC8.3/QSL9/QSM11/SDI/TDI

Products Warranted

This Warranty applies to new Product sold by Cummins MerCruiser Diesel, herein after “CMD”, that is branded as Cummins MerCruiser Diesel product and used in Commercial and Government Marine Propulsion applications anywhere in the world as permitted by US ITAR and Export Compliance regulations where CMD approved service is available* and delivered to the first user on or after May 1, 2011.

This Warranty covers any failures of the Product, under normal use and service, which results from a defect in CMD material or workmanship (Warrantable Failure). The (Product) includes the Engine, controls and other components other than pods or sterndrives as delivered from the CMD factory and accessories with a CMD part number that are added by a CMD approved distributor or OEM. Pods and sterndrives are covered under a separate CMD Warranty.

COMMERCIAL USE

Commercial use is defined as any work or employment related use of the product, or any use of the product which generates income, or any part of the warranty period, even if the product is only occasionally used for such purposes.

GOVERNMENT USE

Government use is defined as use by Federal, State, and Local agencies in non-revenue producing applications.

MARINE PROPULSION RATINGS

Government Service (GS) Rating

Intended for use in variable load applications where full power is limited to one hour out of every eight hours of operation.

Reduced power operation must be at or below cruise speed (rpm). Cruise speed (rpm) is dependent on the engine rated speed (rpm):

Rated Speed (rpm)	Cruise Speed (Reduction from rated speed, rpm)
2,000 to 2,800 rpm	200 rpm below rated
2,801 to 3,500 rpm	300 rpm below rated
3,501 to 4,500 rpm	400 rpm below rated

Government Service (GS)

The Government Service Rating applies to Government use in variable load applications where annual use is less than 500 hours and full power is one (1) out of every eight (8) hours of operation. Reduced power operation must be at or below cruise speed.

Light Commercial (LC)

The Light Commercial Rating applies to Commercial use in variable load applications where annual use is less than 500 hours and full power is one (1) out of every eight (8) hours of operation. Reduced power operation must be at or below cruise speed.

Intermittent Duty (ID)

This power rating is intended for intermittent use in variable load applications where full power is limited to two hours out of every eight hours of operation. Also, reduced power operations must be at or below 200 rpm of the maximum rated rpm. This rating is an ISO3046 Fuel Stop Power Rating and is for applications that operate less than 1,500 hours per year.

Medium Duty (MD)

This power rating is intended for continuous use in variable load applications where full power is limited to six hours out of every twelve hours of operation. Also, reduced power operations must be at or below 200 rpm of the maximum rated rpm. This rating is an ISO3046 Fuel Stop Power Rating and is for applications that operate less than 3,000 hours per year.

Heavy Duty (HD)

This power rating is intended for continuous use in variable load applications where full power is limited to eight hours out of every ten hours of operation. Also, reduced power must be at least 200 rpm below the maximum rated rpm. This rating is an ISO3046 Fuel Stop Power Rating and is for applications that operate less than 5,000 hours per year.

Continuous Duty (CD)

This power rating is intended for continuous use in applications requiring uninterrupted service at full power. This rating is an ISO3046 Standard Power Rating.

Base Engine Warranty

This warranty covers any failures of the Product, under normal use and service, which result from a defect in CMD material or factory workmanship (Warrantable Failure). Coverage begins with the sale of the Engine by CMD and continues for the Duration stated in the following table. The Duration commences on either the date of delivery of the Product to the first end-user, or the date the unit is first leased, rented or loaned, or when the Product has been operated for 50 hours, whichever occurs first. The Base Coverage duration ends two (2) years after the in-service date or allowed hours of total operation, whichever occurs first.

Warranty Coverage Periods				
Rating	QSB, QSC, QSL, SDI, TDI		QSM11	
	Coverage ends at whichever occurs first, months or hours of usage.		Coverage ends at whichever occurs first, months or hours of usage.	
	Months	Hours	Months	Hours
Government Service (GS)	24	1,000	24	1,000

Warranty Coverage Periods				
Rating	QSB, QSC, QSL, SDI, TDI		QSM11	
Light Commercial (LC)	24	1,000	NA	NA
Intermittent Duty (ID)	24	3,000	24	3,000
Medium Duty (MD)	24	5,000	24	6,000
Heavy Duty (HD)	24	5,500	24	8,000
Continuous Duty (CD)	24	6,500	24	9,000

Cummins MerCruiser Diesel Responsibilities

During Engine Warranty

CMD will pay for all parts and labor needed to repair the damage to the Product resulting from a Warrantable Failure when performed during normal business hours. All labor costs will be paid in accordance with Cummins published Standard Repair Time guidelines.

When it is necessary for mechanics to make on-site warranty repairs CMD will pay reasonable travel expenses, including meals, mileage and lodging, for mechanics to travel to and from the repair dock. Labor must be performed by an authorized CMD Repair Facility.

CMD will pay for the lubricating oil, antifreeze, filter elements, and other maintenance items that are not reusable due to the Warrantable Failure.

CMD will pay for reasonable labor costs for Engine removal and reinstallation when necessary to repair a Warrantable Failure.

Owner Responsibilities

During the Engine Warranty

Owner is responsible for the operation and maintenance of the Product as specified in the applicable CMD Operation and Maintenance Manual. Owner is also responsible for providing proof that all recommended maintenance has been performed. This warranty does not cover normal wear and tear of covered parts. Exceeding the operational parameters of the rating will void this Warranty. The Owner of the boat is ultimately responsible for ensuring the Engine is properly operated and maintained. The Warranty will be void on any Engines that are misapplied, not maintained properly or misused.

Before the expiration of the applicable warranty, Owner must notify a CMD service provider, distributor, authorized dealer, or other repair location approved by CMD of any Warrantable Failure and make the Engine available for repair by such facility. Locations in the United States and Canada are listed in the Cummins U.S. and Canada Sales and Service Directory; other locations are listed in the CMD International Sales and Service Directory.

Owner is responsible for the cost of lubricating oil, antifreeze, filter elements, and other maintenance items replaced during warranty repairs unless such items are not reusable due to the Warrantable Failure.

Owner is responsible for communication expenses, meals, lodging, and similar costs incurred as a result of a Warrantable Failure.

Owner is responsible for non-Engine repairs, "downtime" expenses, cargo damage, fines, all applicable taxes, all business costs, and other losses resulting from a Warrantable Failure.

In the event of any Product failure, Owner is responsible for the cost of towing the boat to the repair dock and for all associated docking and harbor charges.

Owner is responsible for maintaining the Engine hourmeter in good working order at all times and to ensure that the hourmeter accurately reflects the total hours of operation of the Product.

Owner is responsible for the costs to investigate complaints, unless the problem is caused by a defect in CMD material or factory workmanship.

Limitations

1. Maintenance Component Limitations

CMD will replace certain maintenance components if they fail within 90 days or less after the base coverage starts. Maintenance components include but are not limited to: sea water pump impellers, zinc plugs, oil filters, fuel filters, air filters, water filters, fuel/water separator filters, expansion tank pressure caps, belts, hoses.

2. Other Component Limitations

CMD does not warrant components that are not supplied by CMD factory.

3. CMD supplied alternators and starters limitation

Warranty coverage is limited to 2 years or 2,000 hours, whichever expires first for rating other than Government Service.

Warranty coverage is limited to 2 years or 1,000 hours, whichever expires first for the Government Service rating.

Consumer Products

The warranty on Consumer Products in the United States is a limited warranty. **CMD IS NOT RESPONSIBLE FOR INCIDENTAL OR CONSEQUENTIAL DAMAGES.** Any implied warranties applicable to Consumer Products terminate concurrently with the expiration of the express warranties applicable to the Product. In the United States, some states do not allow the exclusion of incidental or consequential damages, or limitations on how long an implied warranty lasts, so the above limitations or exclusions may not apply to you.

CMD is not responsible for failures or damage resulting from what CMD determines to be abuse or neglect, including, but not limited to: operation without adequate coolants or lubricants; overfueling; overspeeding; lack of maintenance of cooling, lubricating or intake systems; improper storage, starting, warm-up, run-in or shutdown practices; unauthorized modifications to the engine; improper propping that does not allow the engine to run at its maximum rated speed; submersion, freezing temperatures, improper service, removal of parts, or running the engine out of water; water

ingestion, unless caused by a Warrantable failure. CMD is also not responsible for failures caused by incorrect oil or fuel or by water, dirt or other contaminants in the fuel or oil.

Before a claim for excessive oil consumption will be considered, Owner must submit adequate documentation to show that oil consumption exceeds CMD published standards.

CMD is not responsible for failures of maintenance components supplied by CMD beyond 90 days after the coverage duration start date. Maintenance components include, but are not limited to: sea water pump impellers; zinc plugs; oil filters; fuel filters; air filters; water filters; fuel/water separator filters.

Parts used in warranty repairs may be new CMD parts, CMD approved rebuilt parts, or repaired parts. CMD is not responsible for failures resulting from the use of parts not supplied by CMD.

A new CMD or CMD approved rebuilt part used to replace a Warranted Part assumes the identity of the Warranted Part it replaced and is entitled to the remaining coverage hereunder.

CMD DOES NOT COVER WEAR OR WEAROUT OF COVERED PARTS.

CMD IS NOT RESPONSIBLE FOR INCIDENTAL OR CONSEQUENTIAL DAMAGES.

THESE WARRANTIES SET FORTH HEREIN ARE THE SOLE WARRANTIES MADE BY CMD IN REGARD TO THESE ENGINES. CMD MAKES NO OTHER WARRANTIES, EXPRESS OR IMPLIED, OR OF MERCHANTABILITY OR FITNESS FOR A PARTICULAR PURPOSE.

Emission Warranty

Products Warranted

This Emission Warranty applies to new Engines certified to United States EPA 40 CFR 94 sold by CMD that are installed in vessels flagged or registered in the United States**.

Coverage

CMD warrants to the first user and each subsequent purchaser that the Engine is designed, built, and equipped so as to conform at the time of sale by CMD with all U.S. Federal emission regulations applicable at the time of manufacture

and that it is free from defects in workmanship or material which would cause it not to meet these regulations within the longer of the following periods: (A) Five years or 5,000 hours of operation, whichever occurs first. The Emissions Warranty starts from the date of delivery of the Engine to the first user, or the date the unit is first leased, rented, or loaned, or when the Engine has been operated for 50 hours, whichever occurs first, or (B) The Base Engine Warranty.

Limitations

The owner may elect to have maintenance, replacement, or repair of the emission control parts performed by a facility other than a CMD distributor, an authorized dealer or a repair location approved by CMD, and may elect to use parts other than new genuine CMD or CMD approved rebuilt parts and assemblies for such maintenance, replacement or repair; however, the cost of such service or parts and subsequent failures resulting from such service or parts will not be covered under this emission control system warranty.

Failures, except those resulting from a defect in materials, or factory workmanship, are not covered by this WARRANTY.

CMD IS NOT RESPONSIBLE FOR INCIDENTAL OR CONSEQUENTIAL DAMAGES.

In the United States** and Canada, this warranty gives you specific legal rights, and you may also have other rights which vary from state to state.

Outside the United States** and Canada, in case of consumer sales, in some countries the Owner has statutory rights which cannot be affected or limited by the terms of this warranty.

Nothing in this warranty excludes or restricts any contractual rights the Owner may have against third parties.

* Locations in the United States and Canada are listed in the Cummins United States and Canada Sales and Service Directory; other locations are listed in the Cummins International Sales and Service Directory.

** United States includes American Samoa, the Commonwealth of Northern Mariana Islands, Guam, Puerto Rico, and the U.S. Virgin Islands.

California Emission Control System Warranty, Off-Highway Products Warranted

This Emission Control System Warranty applies to off-road diesel engines certified with the California Air Resources Board beginning with the year 1996 for engines up to 750 horsepower, beginning with the year 2000 for 751 horsepower and over, marketed by Cummins, and registered in California for use in industrial off-highway applications.

Your Warranty Rights and Obligations

The California Air Resources Board and Cummins Engine Company, Inc., are pleased to explain the emission control system warranty on your engine. In California, new off-road diesel engines must be designed, built and equipped to meet the State's stringent anti-smog standards. Cummins must warrant the emission control system on your engine for the periods of time listed below provided there has been no abuse, neglect or improper maintenance of your engine.

Your emission control system may include parts such as the fuel injection system and the air induction system. Also included may be hoses, belts, connectors and other emission-related assemblies.

Where a warrantable condition exists, Cummins will repair your off-road diesel engine at no cost to you including diagnosis, parts and labor.

Manufacturer's Warranty Coverage

This warranty coverage is provided for 5 years or 3,000 hours of engine operation, whichever first occurs from the date of delivery of the engine to the first user. If any emission-related part on your engine is defective, the part will be repaired or replaced by Cummins.

Coverage

This emission control system warranty applies only to the following A series, B3.3, B3.9, B4.5^s, B5.9, B6.7^s, QSB3.9-30, QSB4.5-30, QSB5.9-30, QSB5.9-44, C8.3, QSC8.3, and QSL9 emission control parts:

Fuel Pump	Intake Manifold
Static Timing	Charge Air Cooler
Delivery Valve	Aftercooler
Injection Control Valve Module	
	Exhaust Manifold
Injectors	
Calibration	Oxidation Catalyst
Needle	
Nozzle	Electronic Control System
Spring	Control Module
	Boost Pressure Sensor
Turbocharger	Coolant Temperature Sensor
Compressor Wheel	Fuel Pressure Sensor
Turbine Wheel	
Turbine Oil Seal	
Wastegate Valve	

Owner's Warranty Responsibilities

As the off-road diesel engine owner, you are responsible for the performance of the required maintenance listed in your Cummins Operation and Maintenance Manual. Cummins recommends that you retain all receipts covering maintenance on your off-road diesel engine, but Cummins cannot deny warranty solely for the lack of receipts or for your failure to ensure the performance of all scheduled maintenance.

You are responsible for presenting your off-road diesel engine to a Cummins dealer as soon as a problem exists. The warranty repairs should be completed in a reasonable amount of time, not to exceed 30 days.

As the off-road diesel engine owner, you should also be aware that Cummins may deny you warranty coverage if your off-road diesel engine or a part has failed due to abuse, neglect, improper maintenance or unapproved modifications.

Your engine is designed to operate on diesel fuel only. Use of any other fuel may result in your engine no longer operating in compliance with California's emissions requirements.

If you have any questions regarding your warranty rights and responsibilities, you should contact Cummins Customer Assistance Department at 1-800-343-7357 (1-800-DIESELS) or the California Air Resources Board at 9528 Telstar Avenue, El Monte, CA 91731.

Prior to the expiration of the applicable warranty, Owner must give notice of any warranted emission control failure to a Cummins distributor, authorized dealer or other repair location approved by Cummins and deliver the engine to such facility for repair. Repair locations are listed in Cummins United States and Canada Service Directory.

Owner is responsible for incidental costs such as: communication expenses, meals, lodging incurred by Owner or employees of Owner as a result of a warrantable failure.

Owner is responsible for business costs and losses, "downtime" expenses, and cargo damage resulting from a warrantable failure. CUMMINS IS NOT RESPONSIBLE FOR OTHER INCIDENTAL OR CONSEQUENTIAL DAMAGES, INCIDENTAL OR CONSEQUENTIAL DAMAGES INCLUDE BUT ARE NOT LIMITED TO FINES, THEFT, VANDALISM OR COLLISIONS.

Replacement Parts

Cummins recommends that any service parts used for maintenance, repair or replacement of emission control systems be new, genuine Cummins or Cummins approved rebuilt parts and assemblies, and that the engine be serviced by a Cummins distributor, authorized dealer or the repair location approved by Cummins. The owner may elect to have maintenance, replacement or repair of the emission control parts performed by a facility other than a Cummins distributor, an authorized dealer or a repair location approved by Cummins, and may elect to use parts other than new genuine Cummins or Cummins approved rebuilt parts and assemblies for such maintenance, replacement or repair; however, the cost of such service or parts will not be covered under this emission control system warranty.

Cummins Responsibilities

Repairs and service will be performed by any Cummins distributor, authorized dealer or other repair location approved by Cummins using new, genuine Cummins or Cummins approved rebuilt parts and assemblies. Cummins will repair any of the emission control parts found by Cummins to be defective without charge for parts or labor (including diagnosis which results in determination that there has been a failure of a warranted emission control part).

Emergency Repairs

In the case of an emergency where a Cummins distributor, authorized dealer, or other repair location approved by Cummins is not available, repairs may be performed by any available repair location using any replacement parts. Cummins will reimburse the Owner for expenses (including diagnosis), not to exceed the manufacturer's suggested retail price for all warranted parts replaced and labor charges based on the manufacturer's recommended time allowance for the warranty repair and the geographically appropriate hourly labor rate. A part not being available within 30 days or a repair not being complete within 30 days constitutes an emergency. Replaced parts and paid invoices must be presented at a Cummins authorized repair facility as a condition of reimbursement for emergency repairs not performed by a Cummins distributor, authorized dealer, or other repair location approved by Cummins.

Warranty Limitations

Cummins is not responsible for failures resulting from Owner or operator abuse or neglect, such as: operation without adequate coolant, fuel or lubricants; overfueling; overspeeding; lack of maintenance of lubricating, cooling or air intake systems; improper storage, starting, warm-up, run-in or shutdown practices.

The manufacturer warrants to the ultimate purchaser and each subsequent purchaser that the engine is designed, built, and equipped so as to conform with all applicable regulations adopted by the Air Resources Board, and that it is free from defects in materials and workmanship which cause the failure of a warranted part.

Any warranted part which is not scheduled for replacement as required maintenance, or which is scheduled only for regular inspection to the effect of "repair or replace as necessary" is warranted for the warranty period.

Any warranted part which is scheduled for replacement as required maintenance is warranted for the period of time prior to the first scheduled replacement point for that part.

The owner will not be charged for diagnostic labor which leads to the determination that a warranted part is defective, if the diagnostic work is performed at a warranty station.

The manufacturer is liable for damages to other engine components caused by the failure under warranty of any warranted part.

Cummins is not responsible for failures resulting from improper repair or the use of parts which are not genuine Cummins or Cummins approved parts.

These warranties, together with the express commercial warranties and emission warranty are the sole warranties of Cummins. There are no other warranties, express or implied, or of merchantability or fitness for a particular purpose.

Acronyms and Abbreviations	i-7	General Information.....	1-10
General Information.....	i-7	Engine Shutdown	1-12
Additional Service Literature	L-1	General Information.....	1-12
General Information.....	L-1	Fuel Recommendations and Specifications	V-6
California Emission Control System Warranty, Off-Highway	W-21	Fuel Recommendations.....	V-6
Owner's Warranty Responsibilities	W-23	General Engine	V-1
Cold Weather Starting	1-6	Specifications.....	V-1
General Information.....	1-6	General Safety Instructions	i-3
Using Starting Aids.....	1-7	Important Safety Notice.....	i-3
Coolant Recommendations and Specifications	V-14	Illustrations	i-2
Cooling System Sealing Additives.....	V-17	General Information.....	i-2
Cooling System Soluble Oils.....	V-18	Lubricating Oil Recommendations and Specifications	V-8
Fully Formulated Coolant/Antifreeze.....	V-14	AfterMarket Oil Additive Usage.....	V-13
Cooling System	V-3	General Information.....	V-8
Specifications.....	V-3	New Engine Break-in Oils.....	V-13
.....	W-22	Lubricating Oil System	V-2
Cummins Customized Parts Catalog	L-4	Specifications.....	V-2
General Information.....	L-4	Maintenance Guidelines - Overview	2-1
Ordering the Customized Parts Catalog.....	L-4	General Information.....	2-1
Ordering by Telephone.....	L-4	Maintenance Record Form	2-6
Ordering On-Line.....	L-5	Maintenance Data.....	2-6
Cummins® Service Engine Model Product Identification	E-6	Maintenance Schedule	2-2
General Information.....	E-6	General Information.....	2-2
Cummins®/Fleetguard® Filter Specifications	V-4	Oil Drain Intervals.....	2-4
General Information.....	V-4	Normal Starting Procedure	1-4
Electromagnetic Interference (EMI)	1-12	General Information.....	1-4
General Information.....	1-12	All Engines International Industrial (Off-Highway)	W-8
System EMI Radiation Levels.....	1-13	All Engines United States And Canada Industrial (Off-Highway)	W-1
System EMI Susceptibility.....	1-13	Operating Instructions - Overview	1-1
Engine Identification	E-1	General Information.....	1-1
Cummins® Engine Nomenclature.....	E-4	Operating the Engine	1-8
ECM Dataplate.....	E-5	Normal.....	1-8
Engine Dataplate.....	E-1	Winterfronts and Shutters.....	1-9
Fuel Injection Pump Dataplate.....	E-4	CMD Quantum Commercial Marine Propulsion (QSB5.9/QSB6.7/QSC8.3/ QSL9/QSM11/SDI/TDI)	W-13
Engine Operating Range	1-10		

Index

Page X-2

Service Literature Ordering Location	L-3
Contact Information.....	L-3
Starting Procedure After Extended Shutdown or Oil Change	1-7
General Information.....	1-7
Symbols	i-1
General Information.....	i-1

CALIFORNIA
Proposition 65 Warning

Diesel engine exhaust and some of its constituents are known to the State of California to cause cancer, birth defects, and other reproductive harm.

Cummins Inc.

Box 3005

Columbus, Indiana, U.S.A., 47202

Registered Office

Cummins Ltd.

49 - 51 Gresham Road,

Staines,

Middlesex TW18 2BD,

England

Registration 573951 England

Copyright© 2013

Cummins Inc.

Cummins Customer Assistance Center

1-800-DIESELS™ (1-800-343-7357)

APPLICABLE ONLY IN U.S.A. AND CANADA

Bulletin 4915536

Printed in U.S.A. 13-SEPTEMBER-2013

