



Service Manual ISB^e, ISB, and QSB (Common Rail Fuel System) Volume 1

SYMPTOM: COOLANT TEMPERATURE ABOVE NORMAL

Cause

- Low Coolant Level
OK
- Collapsed Radiator Hose
OK
- Engine Lubricating Oil Level is too High or Low
OK
- Engine is Receiving too Much Fuel
OK
- Dirty Engine (Exterior)
OK
- Loose Fan Drive Belt
OK
- Radiator Shut Opening Closed
OK
- Temperature Sensor Faulty

Correction
Add Coolant. Refer to Section 1000.





Service Manual ISB[®], ISB, and QSB (Common Rail Fuel System) Volume 1

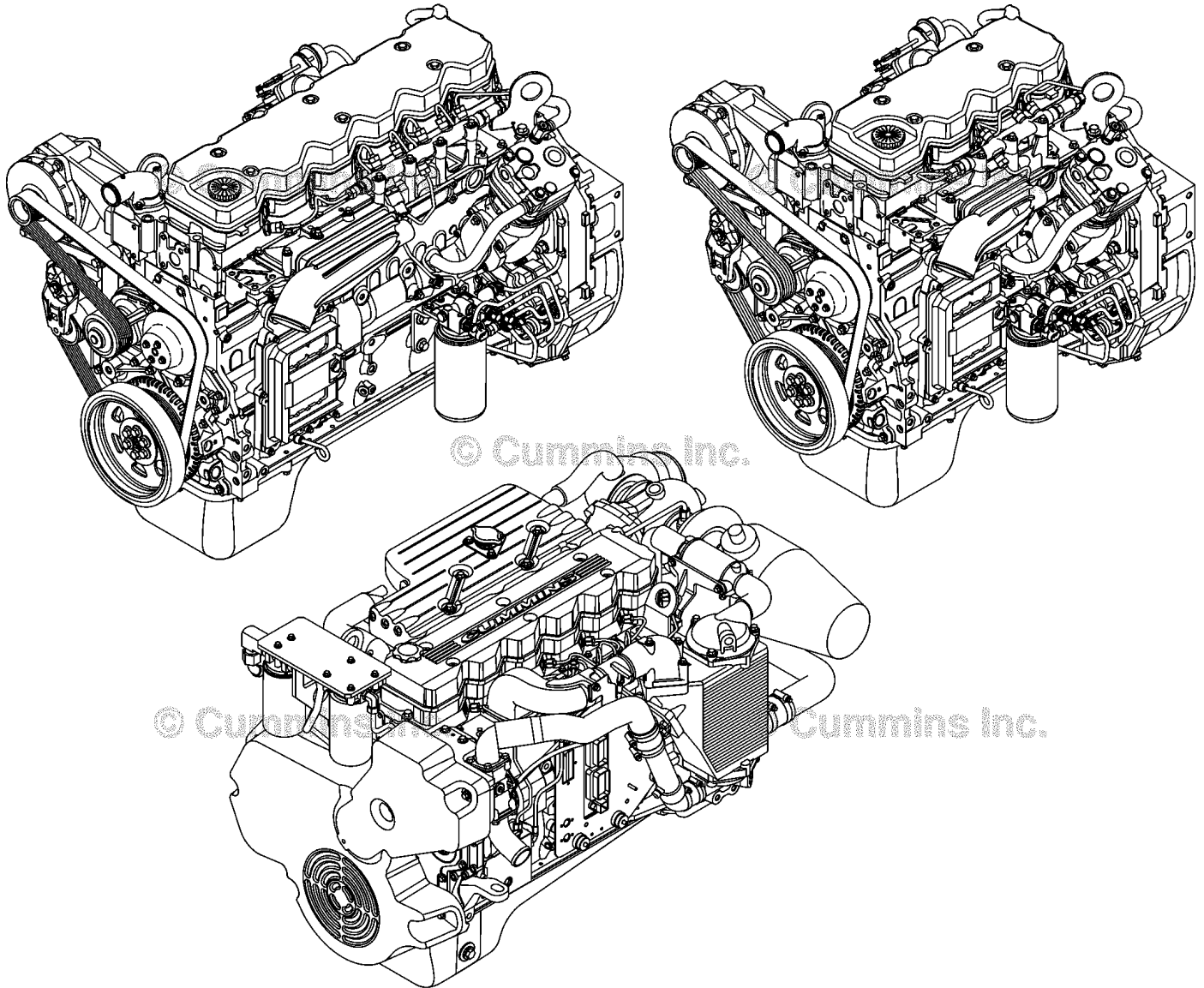

Copyright© 2014
Cummins Inc.
All rights reserved

00d00158
Bulletin 4021271
Printed 23-APRIL-2014

Foreword

This manual provides instructions for troubleshooting and repairing this engine in the chassis. Component and assembly rebuild procedures are provided in the engine shop manual. Refer to Section i - Introduction for instructions on how to use this manual.

Read and follow all safety instructions. Refer to the WARNING in the General Safety Instructions in Section i - Introduction.

The manual is organized to guide a service technician through the logical steps of identifying and correcting problems related to the engine. This manual does not cover vehicle or equipment problems. Consult the vehicle or equipment manufacturer for repair procedures.

A series of specific service manuals (for example: Shop, Specifications, and Alternative Repair) are available and can be ordered by contacting your local area Cummins Regional office. A Cummins Regional office listing is located in Service Literature (Section L).

The repair procedures used in this manual are recommended by Cummins Inc. Some service procedures require the use of special service tools. Use the correct tools as described.

Cummins Inc. encourages the user of this manual to report errors, omissions, and recommendations for improvement. Please use the postage paid, pre-addressed Literature Survey Form in the back of this manual for communicating your comments.

The specifications and rebuild information in this manual are based on the information in effect at the time of printing. Cummins Inc. reserves the right to make any changes at any time without obligation. If differences are found between your engine and the information in this manual, contact a Cummins Authorized Repair Location or call 1-800-DIESELS (1-800-343-7357) toll free in the U.S. and Canada.

The latest technology and the highest quality components are used to manufacture Cummins engines. When replacement parts are needed, we recommend using only genuine Cummins or ReCon® exchange parts.

Table of Contents

	Section
Introduction	i
Engine and System Identification	E
Familiarization	F
Troubleshooting Symptoms	TS
Troubleshooting Symptoms (New Format)	TT
Engine Disassembly - Group 00	DS
Engine Assembly - Group 00	AS
Product - Group 00	0
Cylinder Block - Group 01	1
Cylinder Head - Group 02	2
Rocker Levers - Group 03	3
Cam Followers/Tappets - Group 04	4
Back	back

Section i - Introduction

Section Contents

	Page
About the Manual	i-1
General Information.....	i-1
Acronyms and Abbreviations	i-17
General Information.....	i-17
General Cleaning Instructions	i-12
Abrasive Pads and Abrasive Paper.....	i-12
Definition of Clean.....	i-12
Fuel System.....	i-15
Gasket Surfaces.....	i-13
Plastic Bead Cleaning.....	i-14
Solvent and Acid Cleaning.....	i-13
Steam Cleaning.....	i-14
General Repair Instructions	i-10
General Information.....	i-10
Welding on a Vehicle with an Electronic Controlled Fuel System.....	i-11
General Safety Instructions	i-8
Important Safety Notice.....	i-8
How to Use the Manual	i-2
General Information.....	i-2
Illustrations	i-7
General Information.....	i-7
Symbols	i-3
General Information.....	i-3

This Page Left Intentionally Blank

About the Manual

General Information

This Service Manual is intended to aid in determining the cause of engine related problems and to provide recommended repair procedures. Additionally the manual is intended to aid mechanics in disassembly, inspecting parts for reuse, rebuilding and assembly of components.

The manual is divided into sections. Each section is equivalent to a group used in Cummins' filmcard system. Some sections contain **reference** numbers and **procedure** numbers. **Reference** numbers provide general information, specifications, diagrams, and service tools where applicable. **Procedure** numbers are used to identify and reference specific repair procedures for correcting the problem and describe specific rebuild procedures.

This manual **does not** contain fuel systems electronic troubleshooting. Use the troubleshooting trees in this manual, if there are no electronic fault codes.

This manual is designed so the troubleshooting trees are used to locate the cause of an engine problem. The troubleshooting trees then direct the user to the correct repair procedure. The repair procedures within a section are in numerical order. However, the repair steps within a given procedure are organized in the order the repair **must** be performed regardless of the numerical order of the steps. The user **must** use the contents pages or the index at the back of the manual to locate specific topics when **not** using the troubleshooting trees.

How to Use the Manual

General Information

This manual is divided into the same group system used for previous manuals and the Cummins' filmcard system. Section 00 is organized into a logical sequence of engine disassemble/assemble, all other sections are in numerical sequence. Refer to the Table of Contents at the front of the book to determine the section that details the desired information.

The disassemble/assemble sections of this manual is divided into the same group system used for previous manuals and the Cummins' filmcard system.

Section 00 is organized into a logical sequence of engine disassemble/assemble, all other sections are in numerical sequence. Refer to the Table of Contents at the front of the book to determine the section that details the desired information.

Each section contains the following in sequence:

- Table of Contents
- Required Service Tool Listings
- General Information containing the basic service, maintenance, design and revision information necessary to assist in the rebuild of an engine or a component
- Procedure instructions for the disassembly, inspection, maintenance, and assembly that can be required to rebuild an engine; additional procedures that are **not** necessary during **every** rebuild, but can be necessary, are included. These procedures depend on the length of time an engine has been in service and the conditions of the parts.

All the procedures are identified with a name and a number. Each digit in the procedure number has a specific meaning.

The first three digits of the number refer to the specific section that the procedure can be found within the manual. In this example, "001" represents Section 01 - Cylinder Block. This number will range from 000 to 022.

The second three digits of the number are unique and refer to a specific subject. In this example, "028" represents Cylinder Liner. This number will range from 001 to 999.

Refer to Section V for specifications recommended by Cummins Engine Company, Inc. for your engine. Specifications and torque values for each engine system are given in that section.

NOTE: Discharge of oil or oily water into or upon the water is a direct violation of today's laws. Violators are subject to a penalty of various monetary charges. Dispose of these substances in accordance with standards set by the local environmental governing agency.

Symbols

General Information

The symbols have been used in this manual to help communicate the intent of the instructions. When one of the symbols appears, it conveys the meaning defined below.

NOTE: It is possible to have four symbols for each text and graphic combination.



WARNING
Serious personal injury or extensive property damage can result if the warning instructions are not followed.



CAUTION
Minor personal injury can result or a part, and assembly, or the engine can be damaged if the caution instructions are not followed.

Indicates a **REMOVAL** or **Dissassembly** step.





Indicates an **INSTALLATION** or **ASSEMBLY** step.



INSPECTION is required.



CLEAN the part or assembly.



PERFORM a mechanical or time **MEASUREMENT**.

LUBRICATE the part or assembly.



Indicates that a **WRENCH** or **TOOL SIZE** will be given.



TIGHTEN to a specific torque.



PERFORM an electrical **MEASUREMENT**.





Refer to another location in this manual or another publication for additional information.



The component weighs 23kg [50 lbs] or more. To reduce the possibility of personal injury, use a hoist or get assistance to lift the component.



To reduce the risk of high voltage shock, always follow all warnings and service instructions. Always assume the vehicle and its high voltage system are energized, even if the engine is not running.



Approved high voltage insulated gloves are required for this procedure.



Illustrations

General Information

Some of the illustrations throughout this manual are generic and will **not** look exactly like the engine or parts used in your application. The illustrations can contain symbols to indicate an action required and an acceptable or **not** acceptable condition.

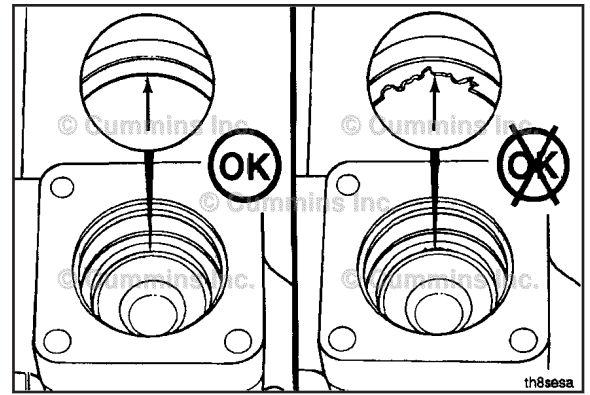

The illustrations are intended to show repair or replacement procedures. The procedure will be the same for all applications, although the illustration can differ.

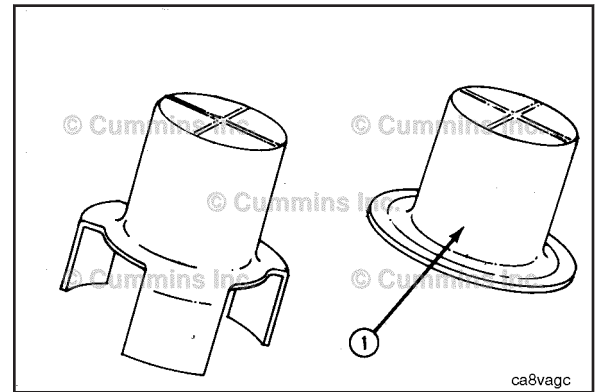

General Safety Instructions

Important Safety Notice



Improper practices, carelessness, or ignoring the warnings can cause burns, cuts, mutilation, asphyxiation or other personal injury or death.

Read and understand all of the safety precautions and warnings before performing any repair. This list contains the general safety precautions that **must** be followed to provide personal safety. Special safety precautions are included in the procedures when they apply.

- Work in an area surrounding the product that is dry, well lit, ventilated, free from clutter, loose tools, parts, ignition sources and hazardous substances. Be aware of hazardous conditions that can exist.
- **Always** wear protective glasses and protective shoes when working.
- Rotating parts can cause cuts, mutilation or strangulation.
- Do **not** wear loose-fitting or torn clothing. Remove all jewelry when working.
- Disconnect the battery (negative [-] cable first) and discharge any capacitors before beginning any repair work. Disconnect the air starting motor if equipped to prevent accidental engine starting. Put a "Do **Not** Operate" tag in the operator's compartment or on the controls.
- Use **ONLY** the proper engine barring techniques for manually rotating the engine. Do **not** attempt to rotate the crankshaft by pulling or prying on the fan. This practice can cause serious personal injury, property damage, or damage to the fan blade(s) causing premature fan failure.
- If an engine has been operating and the coolant is hot, allow the engine to cool before slowly loosening the filler cap to relieve the pressure from the cooling system.
- **Always** use blocks or proper stands to support the product before performing any service work. Do **not** work on anything that is supported **ONLY** by lifting jacks or a hoist.
- Relieve all pressure in the air, oil, fuel, and cooling systems before any lines, fittings, or related items are removed or disconnected. Be alert for possible pressure when disconnecting any device from a system that utilizes pressure. Do **not** check for pressure leaks with your hand. High pressure oil or fuel can cause personal injury.
- To reduce the possibility of suffocation and frostbite, wear protective clothing and **ONLY** disconnect liquid refrigerant (Freon) lines in a well ventilated area. To protect the environment, liquid refrigerant systems **must** be properly emptied and filled using equipment that prevents the release of refrigerant gas (fluorocarbons) into the atmosphere. Federal law requires capturing and recycling refrigerant.
- To reduce the possibility of personal injury, use a hoist or get assistance when lifting components that weigh 23 kg [50 lb] or more. Make sure all lifting devices such as chains, hooks, or slings are in good condition and are of the correct capacity. Make sure hooks are positioned correctly. **Always** use a spreader bar when necessary. The lifting hooks **must not** be side-loaded.
- Corrosion inhibitor, a component of SCA and lubricating oil, contains alkali. Do **not** get the substance in eyes. Avoid prolonged or repeated contact with skin. Do **not** swallow internally. In case of contact, immediately wash skin with soap and water. In case of contact, immediately flood eyes with large amounts of water for a minimum of 15 minutes. **IMMEDIATELY CALL A PHYSICIAN. KEEP OUT OF REACH OF CHILDREN.**
- Naptha and Methyl Ethyl Ketone (MEK) are flammable materials and **must** be used with caution. Follow the manufacturer's instructions to provide complete safety when using these materials. **KEEP OUT OF REACH OF CHILDREN.**
- To reduce the possibility of burns, be alert for hot parts on products that have just been turned off, exhaust gas flow, and hot fluids in lines, tubes, and compartments.
- **Always** use tools that are in good condition. Make sure you understand how to use the tools before performing any service work. Use **ONLY** genuine Cummins® or Cummins ReCon® replacement parts.
- **Always** use the same fastener part number (or equivalent) when replacing fasteners. Do **not** use a fastener of lesser quality if replacements are necessary.
- When necessary, the removal and replacement of any guards covering rotating components, drives, and/or belts should only be carried out by a trained technician. Before removing any guards the engine **must** be turned off and any starting mechanisms **must** be isolated. All fasteners **must** be replaced on re-fitting the guards.
- Do **not** perform any repair when fatigued or after consuming alcohol or drugs that can impair your functioning.

- Some state and federal agencies in the United States of America have determined that used engine oil can be carcinogenic and can cause reproductive toxicity. Avoid inhalation of vapors, ingestion, and prolonged contact with used engine oil.
- Do **not** connect the jumper starting or battery charging cables to any ignition or governor control wiring. This can cause electrical damage to the ignition or governor.
- **Always** torque fasteners and fuel connections to the required specifications. Overtightening or undertightening can allow leakage. This is critical to the natural gas and liquefied petroleum gas fuel and air systems.
- **Always** test for fuel leaks as instructed, as odorant can fade.
- Close the manual fuel valves prior to performing maintenance and repairs, and when storing the vehicle inside.
- Coolant is toxic. If **not** reused, dispose of in accordance with local environmental regulations.
- The catalyst reagent contains urea. Do **not** get the substance in your eyes. In case of contact, immediately flood eyes with large amounts of water for a minimum of 15 minutes. Avoid prolonged contact with skin. In case of contact, immediately wash skin with soap and water. Do **not** swallow internally. In the event the catalyst reagent is ingested, contact a physician immediately.
- The catalyst substrate contains Vanadium Pentoxide. Vanadium Pentoxide has been determined by the State of California to cause cancer. Always wear protective gloves and eye protection when handling the catalyst assembly. Do not get the catalyst material in your eyes. In Case of contact, immediately flood eyes with large amounts of water for a minimum of 15 minutes. Avoid prolonged contact with skin. In case of contact, immediately wash skin with soap and water.
- The Catalyst substrate contains Vanadium Pentoxide. Vanadium Pentoxide has been determined by the State of California to cause cancer. In the event the catalyst is being replaced, dispose of in accordance with local regulations.
- California Proposition 65 Warning - Diesel engine exhaust and some of its constituents are known to the State of California to cause cancer, birth defects, and other reproductive harm.

General Repair Instructions

General Information

This system incorporates the latest technology at the time it was manufactured; yet, it is designed to be repaired using normal repair practices performed to quality standards.

WARNING

Cummins Inc. does not recommend or authorize any modifications or repairs to components except for those detailed in Cummins Service Information. In particular, unauthorized repair to safety-related components can cause personal injury or death. Below is a partial listing of components classified as safety-related:

- 1 Air Compressor
- 2 Air Controls
- 3 Air Shutoff Assemblies
- 4 Balance Weights
- 5 Cooling Fan
- 6 Fan Hub Assembly
- 7 Fan Mounting Bracket(s)
- 8 Fan Mounting Capscrews
- 9 Fan Hub Spindle
- 10 Flywheel
- 11 Flywheel Crankshaft Adapter
- 12 Flywheel Mounting Capscrews
- 13 Fuel Shutoff Assemblies
- 14 Fuel Supply Tubes
- 15 Lifting Brackets
- 16 Throttle Controls
- 17 Turbocharger Compressor Casing
- 18 Turbocharger Oil Drain Line(s)
- 19 Turbocharger Oil Supply Line(s)
- 20 Turbocharger Turbine Casing
- 21 Vibration Damper Mounting Capscrews
- 22 Manual Service Disconnect
- 23 High Voltage Interlock Loop
- 24 High Voltage Connectors/Connections and Harnesses
- 25 High Voltage Battery System
- 26 Power Inverter
- 27 Generator Motor
- 28 Clutch Pressure Plate

- Follow all safety instructions noted in the procedures
- Follow the manufacturer's recommendations for cleaning solvents and other substances used during repairs. Some solvents have been identified by government agencies as toxic or carcinogenic. Avoid excessive breathing, ingestion and contact with such substances. **Always** use good safety practices with tools and equipment
- Provide a clean environment and follow the cleaning instructions specified in the procedures
- All components **must** be kept clean during any repair. Contamination of the components will cause premature wear.
- Perform the inspections specified in the procedures
- Replace all components or assemblies which are damaged or worn beyond the specifications

To buy Cummins Parts and Service Manuals, Training Guides, or Tools go to our website at <https://store.cummins.com>

- Use genuine Cummins new or ReCon® service parts and assemblies
- The assembly instructions have been written to use again as many components and assemblies as possible. When it is necessary to replace a component or assembly, the procedure is based on the use of new Cummins or Cummins ReCon® components. All of the repair services described in this manual are available from all Cummins Distributors and most Dealer locations.
- Follow the specified disassembly and assembly procedures to reduce the possibility of damage to the components

Welding on a Vehicle with an Electronic Controlled Fuel System

△CAUTION△

Disconnect both the positive (+) and negative (-) battery cables from the battery before welding on the vehicle. Attach the welder ground cable no more than 0.61 meters [2 feet] from the part being welded. Do not connect the ground clamp of the welder to any of the sensors, wiring harness, electronic control units or the components. Direct welding of any electronic components must not be attempted. Sensors, wiring harness, and electronic control unit should be removed if nearby welding will expose these components to temperatures beyond normal operation. Additionally, all electronic control unit connectors must be disconnected

General Cleaning Instructions

Definition of Clean

Parts **must** be free of debris that can contaminate any engine system. This does **not** necessarily mean they have to appear as new.

Sanding gasket surfaces until the factory machining marks are disturbed adds no value and is often harmful to forming a seal. It is important to maintain surface finish and flatness tolerances to form a quality sealing surface. Gaskets are designed to fill small voids in the specified surface finish.

Sanding gasket surfaces where edge-molded gaskets are used is most often unnecessary. Edge-molded gaskets are those metal carriers with sealing material bonded to the edges of the gasket to seal while the metal portion forms a metal to metal joint for stability. Any of the small amounts of sealing material that can stick to the parts are better removed with a blunt-edged scraper on the spots rather than spending time polishing the whole surface with an air sander or disc.

For those gaskets that do **not** have the edge molding, nearly all have a material that contains release agents to prevent sticking. Certainly this is **not** to say that some gaskets are **not** difficult to remove because the gasket has been in place a long time, has been overheated or the purpose of the release agent has been defeated by the application of some sealant. The object however is just to remove the gasket without damaging the surfaces of the mating parts without contaminating the engine (don't let the little bits fall where they can not be removed).

Bead blasting piston crowns until the dark stain is removed is unnecessary. All that is required is to remove the carbon build-up above the top ring and in the ring grooves. There is more information on bead blasting and piston cleaning later in this document.

Cummins Inc. does **not** recommend sanding or grinding the carbon ring at the top of cylinder liners until clean metal is visible. The liner will be ruined and any signs of a problem at the top ring reversal point (like a dust-out) will be destroyed. It is necessary to remove the carbon ring to provide for easier removal of the piston assembly. A medium bristle, high quality, steel wire wheel that is rated above the rpm of the power tool being used will be just as quick and there will be less damage. Yes, one **must** look carefully for broken wires after the piston is removed but the wires are more visible and can be attracted by a magnet.

Oil on parts that have been removed from the engine will attract dirt in the air. The dirt will adhere to the oil. If possible, leave the old oil on the part until it is ready to be cleaned, inspected and installed, and then clean it off along with any attracted dirt. If the part is cleaned then left exposed it can have to be cleaned again before installation. Make sure parts are lubricated with clean oil before installation. They do **not** need to be oiled all over but do need oil between moving parts (or a good lube system priming process conducted before cranking the engine).

Bead blasting parts to remove exterior paint is also usually unnecessary. The part will most likely be painted again so all that needs happen is remove any loose paint.

Abrasive Pads and Abrasive Paper

The keyword here is "abrasive". There is no part of an engine designed to withstand abrasion. That is they are all supposed to lock together or slide across each other. Abrasives and dirt particles will degrade both functions.



Abrasive material must be kept out of or removed from oil passages and parts wear points. Abrasive material in oil passages can cause bearing and bushing failures that can progress to major component damage beyond reuse. This is particularly true of main and rod bearings.

Cummins Inc. does **not** recommend the use of emery cloth or sand paper on any part of an **assembled** engine or component including but **not** limited to removing the carbon ridge from cylinder liners or to clean block decks or counterbores.

Great care **must** be taken when using abrasive products to clean engine parts, particularly on partially assembled engines. Abrasive cleaning products come in many forms and sizes. All of them contain aluminum oxide particles, silicon carbide, or sand or some other similar hard material. These particles are harder than most of the parts in the engine. Since they are harder, if they are pressed against softer material they will either damage the material or become embedded in it. These materials fall off the holding media as the product is used. If the products are used with power equipment the particles are thrown about the engine. If the particles fall between two moving parts, damage to the moving parts is likely.

If particles that are smaller than the clearance between the parts while they are at rest (engine stopped), but larger than the running clearance then damage will occur when the parts move relative to each other (engine started). While the engine is running and there is oil pressure, particles that are smaller than the bearing clearance are likely to pass between the parts without damage and be trapped in the oil filter. However, particles larger than the bearing clearance will remove material from one part and can become embedded in one of the parts. Once embedded in one part it will

abrade the other part until contact is no longer being made between the two parts. If the damage sufficiently degrades the oil film, the two parts will come into contact resulting in early wear-out or failure from lack of effective lubrication.

Abrasive particles can fly about during cleaning it is **very** important to block these particles from entering the engine as much as possible. This is particularly true of lubricating oil ports and oil drilling holes, especially those located downstream of the lubricating oil filters. Plug the holes instead of trying to blow the abrasive particles and debris with compressed air because the debris is often simply blown further into the oil drilling.

All old gasket material **must** be removed from the parts gasket surfaces. However, it is **not** necessary to clean and polish the gasket surface until the machining marks are erased. Excessive sanding or buffing can damage the gasket surface. Many newer gaskets are of the edge molded type (a steel carrier with a sealing member bonded to the steel). What little sealing material that can adhere is best removed with a blunt-edged scraper or putty knife. Cleaning gasket surfaces where an edge-molded gasket is used with abrasive pads or paper is usually a waste of time.



Excessive sanding or grinding the carbon ring from the top of the cylinder liners can damage the liner beyond reuse. The surface finish will be damaged and abrasive particles can be forced into the liner material which can cause early cylinder wear-out or piston ring failures.

Tape off or plug all openings to any component interior before using abrasive pads or wire brushes. If really necessary because of time to use a power tool with abrasive pads, tape the oil drillings closed or use plug and clean as much of the surface as possible with the tool but clean around the oil hole/opening by hand so as to prevent contamination of the drilling. Then remove the tape or plug and clean the remaining area carefully and without the tool. **DO NOT** use compressed air to blow the debris out of oil drilling on an assembled engine! More likely than **not**, the debris can be blown further into the drilling. Using compressed air is fine if both ends of the drilling are open but that is rarely the case when dealing with an assembled engine.

Gasket Surfaces

The object of cleaning gasket surfaces is to remove any gasket material, not refinish the gasket surface of the part.

Cummins Inc. does **not** recommend any specific brand of liquid gasket remover. If a liquid gasket remover is used, check the directions to make sure the material being cleaned will **not** be harmed.

Air powered gasket scrapers can save time but care must be taken to **not** damage the surface. The angled part of the scraper must be against the gasket surface to prevent the blade from digging into the surface. Using air powered gasket scrapers on parts made of soft materials takes skill and care to prevent damage.

Do **not** scrape or brush across the gasket surface if at all possible.

Solvent and Acid Cleaning

Several solvent and acid-type cleaners can be used to clean the disassembled engine parts (other than pistons. See Below). Experience has shown that the best results can be obtained using a cleaner that can be heated to 90° to 95° Celsius (180° to 200° Fahrenheit). Kerosene emulsion based cleaners have different temperature specifications, see below. A cleaning tank that provides a constant mixing and filtering of the cleaning solution will give the best results. Cummins Inc. does not recommend any specific cleaners. Always follow the cleaner manufacturer's instructions. Remove all the gasket material, o-rings, and the deposits of sludge, carbon, etc., with a wire brush or scraper before putting the parts in a cleaning tank. Be careful not to damage any gasket surfaces. When possible, steam clean the parts before putting them in the cleaning tank.



When using solvents, acids, or alkaline materials for cleaning, follow the manufacturers recommendations for use. Wear goggles and protective clothing to reduce the possibility of personal injury.

Experience has shown that kerosene emulsion based cleaners perform the best to clean pistons. These cleaners should **not** be heated to temperature in excess of 77°C (170°F). The solution begins to break down at temperatures in excess of 82°C (180°F) and will be less effective.

Do **not** use solutions composed mainly of chlorinated hydrocarbons with cresols, phenols and/or cresylic components. They often do **not** do a good job of removing deposits from the ring groove and are costly to dispose of properly.

Solutions with a pH above approximately 9.5 will cause aluminum to turn black; therefore do **not** use high alkaline solutions.

Chemicals with a pH above 7.0 are considered alkaline and those below 7.0 are acidic. As you move further away from the neutral 7.0, the chemicals become highly alkaline or highly acidic.

Remove all the gasket material, o-rings, and the deposits of sludge, carbon, etc., with a wire brush or scraper before putting the parts in a cleaning tank. Be careful to **not** damage any gasket surfaces. When possible use hot high

pressure water or steam clean the parts before putting them in the cleaning tank. Removing the heaviest dirt before placing in the tank will allow the cleaner to work more effectively and the cleaning agent will last longer.

Rinse all the parts in hot water after cleaning. Dry completely with compressed air. Blow the rinse water from all the capscrew holes and the oil drillings.

If the parts are **not** to be used immediately after cleaning, dip them in a suitable rust proofing compound. The rust proofing compound **must** be removed from the parts before assembly or installation on the engine.

Steam Cleaning

Steam cleaning can be used to remove all types of dirt that can contaminate the cleaning tank. It is a good method for cleaning the oil drillings and coolant passages



When using a steam cleaner, wear safety glasses or a face shield, as well as protective clothing. Hot steam can cause serious personal injury.

Do **not** steam clean the following components:

- Electrical Components
- Wiring Harnesses
- Belts and Hoses
- Bearings (ball or taper roller)
- Electronic Control Module (ECM)
- ECM Connectors
- Capacitive Coil Driver Module (CCD)
- Ignition Coils and Leads
- NOx Sensor
- Fuel Control Valve
- Throttle Driver and Actuator.

Plastic Bead Cleaning

Cummins Inc. does **not** recommend the use of glass bead blast or walnut shell media on **any** engine part. Cummins Inc. recommends using **only** plastic bead media, Part Number 3822735 or equivalent on any engine part. **Never** use sand as a blast media to clean engine parts. Glass and walnut shell media when **not** used to the media manufacturer's recommendations can cause excess dust and can embed in engine parts that can result in premature failure of components through abrasive wear.

Plastic bead cleaning can be used on many engine components to remove carbon deposits. The cleaning process is controlled by the use of plastic beads, the operating pressure and cleaning time.



Do not use bead blasting cleaning methods on aluminum pistons skirts or the pin bores in any piston, piston skirt or piston crown. Small particles of the media will embed in the aluminum or other soft metal and result in premature wear of the cylinder liner, piston rings, pins and pin bores. Valves, turbocharger shafts, etc., can also be damaged. Follow the cleaning directions listed in the procedures.



Do not contaminate wash tanks and tank type solvent cleaners with the foreign material and plastic beads. Remove the foreign material and plastic beads with compressed air, hot high pressure water or steam before placing them in tanks or cleaners. The foreign material and plastic beads can contaminate the tank and any other engine parts cleaned in the tank. Contaminated parts may cause failures from abrasive wear.

Plastic bead blasting media, Part Number 3822735, can be used to clean all piston ring grooves. Do **not** use any bead blasting media on piston pin bores or aluminum skirts.

Follow the equipment manufacturer's cleaning instructions. Make sure to adjust the air pressure in the blasting machine to the bead manufacturer's recommendations. Turning up the pressure can move material on the part and cause the plastic bead media to wear out more quickly. The following guidelines can be used to adapt to manufacturer's instructions:

- 1 Bead size: U.S. size Number 16 — 20 for piston cleaning with plastic bead media, Part Number 3822735

- 2 Operating Pressure — 270 kPa (40 psi) for piston cleaning. Pressure should not cause beads to break.
- 3 Steam clean or wash the parts with solvent to remove all of the foreign material and plastic beads after cleaning. Rinse with hot water. Dry with compressed air.

⚠CAUTION⚠

The bead blasting operation must not disturb the metal surface. If the metal surface is disturbed the engine can be damaged due to increased parts clearance or inadequate surface finish on parts that move against other parts.

When cleaning pistons, it is **not** necessary to remove all the dark stain from the piston. All that is necessary is to remove the carbon on the rim and in the ring grooves. This is best done by directing the blast across the part as opposed to straight at the part. If the machining marks are disturbed by the blasting process, then the pressure is too high or the blast is being held on one spot too long. The blast operation **must not** disturb the metal surface.

Walnut shell bead blast material is sometimes used to clean ferrous metals (iron and steel). Walnut shell blasting produces a great amount of dust particularly when the pressure if the air pressure on the blasting machine is increased above media manufacturer's recommendation. Cummins Inc. recommends **not** using walnut shell media to clean engine parts due to the risk media embedment and subsequent contamination of the engine.

Cummins Inc. now recommends glass bead media **NOT** used to clean any engine parts. Glass media is too easily embedded into the material particularly in soft materials and when air pressures greater than media manufacturer's recommend are used. The glass is an abrasive so when it is in a moving part, that part is abrading all the parts in contact with it. When higher pressures are used the media is broken and forms a dust of a very small size that floats easily in the air. This dust is very hard to control in the shop, particularly if **only** compressed air (and not hot water) is used to blow the media after it is removed from the blasting cabinet (blowing the part off inside the cabinet may remove large accumulations but never removes all the media).

Bead blasting is best used on stubborn dirt/carbon build-up that has **not** been removed by first steam/higher pressure washing then washing in a heated wash tank. This is particularly true of pistons. Steam and soak the pistons first then use the plastic bead method to safely remove the carbon remaining in the grooves (instead of running the risk of damaging the surface finish of the groove with a wire wheel or end of a broken piston ring. Make sure the parts are dry and oil free before bead blasting to prevent clogging the return on the blasting machine.

Always direct the bead blaster nozzle "across" rather than directly at the part. This allows the bead to get under the unwanted material. Keep the nozzle moving rather than hold on one place. Keeping the nozzle directed at one-place too long causes the metal to heat up and be moved around. Remember that the spray is **not** just hitting the dirt or carbon. If the machining marks on the piston groove or rim have been disturbed then there has **not** been enough movement of the nozzle and/or the air pressure is too high.

Never bead blast valve stems. Tape or use a sleeve to protect the stems during bead blasting. Direct the nozzle across the seat surface and radius rather than straight at them. The object is to remove any carbon build up and continuing to blast to remove the stain is a waste of time.

Fuel System

When servicing any fuel system components, which can be exposed to potential contaminants, prior to disassembly, clean the fittings, mounting hardware, and the area around the component to be removed. If the surrounding areas are **not** cleaned, dirt or contaminants can be introduced into the fuel system.

The internal drillings of some injectors are extremely small and susceptible to plugging from contamination. Some fuel injection systems can operate at very high pressures. High pressure fuel can convert simple particles of dirt and rust into a highly abrasive contaminant that can damage the high pressure pumping components and fuel injectors.

Electrical contact cleaner can be used if steam cleaning tools are **not** available. Use electrical contact cleaner rather than compressed air, to wash dirt and debris away from fuel system fittings. Diesel fuel on exposed fuel system parts attracts airborne contaminants.

Choose lint free towels for fuel system work.

Cap and plug fuel lines, fittings, and ports whenever the fuel system is opened. Rust, dirt, and paint can enter the fuel system whenever a fuel line or other component is loosened or removed from the engine. In many instances, a good practice is to loosen a line or fitting to break the rust and paint loose, and then clean off the loosened material.

When removing fuel lines or fittings from a new or newly-painted engine, make sure to remove loose paint flakes/chips that can be created when a wrench contacts painted line nuts or fittings, or when quick disconnect fittings are removed.

Fuel filters are rated in microns. The word micron is the abbreviation for a micrometer, or one millionth of a meter. The micron rating is the size of the smallest particles that will be captured by the filter media. As a reference, a human hair

is 76 microns [0.003 in] in diameter. One micron measures 0.001 mm [0.00004 in.]. The contaminants being filtered out are smaller than can be seen with the human eye, a magnifying glass, or a low powered microscope.

The tools used for fuel system troubleshooting and repair are to be cleaned regularly to avoid contamination. Like fuel system parts, tools that are coated with oil or fuel attract airborne contaminants. Remember the following points regarding your fuel system tools:

- Fuel system tools are to be kept as clean as possible.
- Clean and dry the tools before returning them to the tool box.
- If possible, store fuel system tools in sealed containers.
- Make sure fuel system tools are clean before use.

Acronyms and Abbreviations

General Information

The following list contains some of the acronyms and abbreviations used in this manual.

ANSI	American National Standards Institute
API	American Petroleum Institute
ASTM	American Society of Testing and Materials
ATDC	After Top Dead Center
BTU	British Thermal Unit
BTDC	Before Top Dead Center
°C	Celsius
CAN	Controller Area Network
CO	Carbon Monoxide
CCA	Cold Cranking Amperes
CARB	California Air Resources Board
C.I.B.	Customer Interface Box
C.I.D.	Cubic Inch Displacement
CNG	Compressed Natural Gas
CPL	Control Parts List
cSt	Centistokes
DEF	Diesel Exhaust Fluid
DOC	Diesel Oxidation Catalyst
DPF	Diesel Particulate Filter
ECM	Engine Control Module
EFC	Electronic Fuel Control
EGR	Exhaust Gas Recirculation
EPA	Environmental Protection Agency
°F	Fahrenheit
ft-lb	Foot-Pound Force
FMI	Failure Mode Identifier
GVW	Gross Vehicle Weight
Hg	Mercury
hp	Horsepower
H₂O	Water
inHg	Inches of Mercury
in H₂O	Inches of Water
ICM	Ignition Control Module
IEC	International Electrotechnical Commission
km/l	Kilometers per Liter
kPa	Kilopascal
LNG	Liquid Natural Gas
LPG	Liquified Petroleum Gas
LTA	Low Temperature Aftercooling
MCRS	Modular Common Rail System
MIL	Malfunction Indicator Lamp
MPa	Megapascal
mph	Miles Per Hour
mpq	Miles Per Quart
N•m	Newton-meter

NOx	Mono-Nitrogen Oxides
NG	Natural Gas
O2	Oxygen
OBD	On-Board Diagnostics
OEM	Original Equipment Manufacturer
OSHA	Occupational Safety and Health Administration
PID	Parameter Identification Descriptions
ppm	Parts Per Million
psi	Pounds Per Square Inch
PTO	Power Takeoff
REPTO	Rear Power Take Off
RGT	Rear Gear Train
rpm	Revolutions Per Minute
SAE	Society of Automotive Engineers
SCA	Supplemental Coolant Additive
SCR	Selective Catalytic Reduction
STC	Step Timing Control
SID	Subsystem Identification Descriptions
TDC	Top Dead Center
VDC	Volts of Direct Current
VGT	Variable Geometry Turbocharger
VS	Variable Speed
VSS	Vehicle Speed Sensor

Section E - Engine and System Identification

Section Contents

	Page
Cummins® Service Engine Model Product Identification	E-45
General Information.....	E-45
Engine Diagrams	E-6
Engine Views.....	E-6
Engine Identification	E-1
Cummins® Engine Nomenclature.....	E-3
ECM Dataplate.....	E-4
Engine Dataplate.....	E-1
Fuel Injection Pump Dataplate.....	E-4

This Page Left Intentionally Blank

Engine Identification

Engine Dataplate

Automotive and Industrial

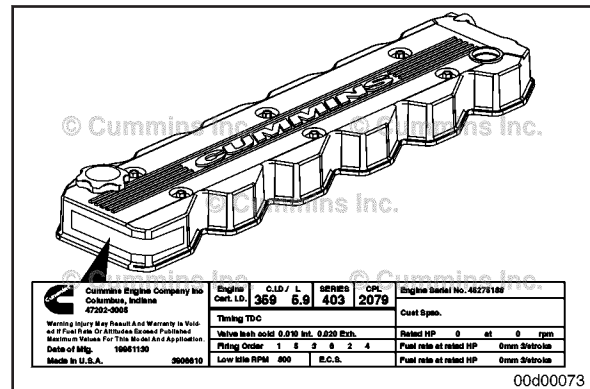
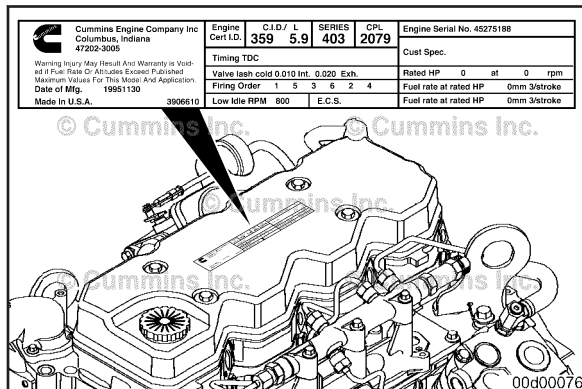

The engine dataplate shows specific facts about your engine. The dataplate is typically located on the engine rocker cover, but may be located on the side of the gear housing. The engine serial number and CPL provide data for ordering parts and service. The engine dataplate **must not** be changed unless approved by Cummins Inc.

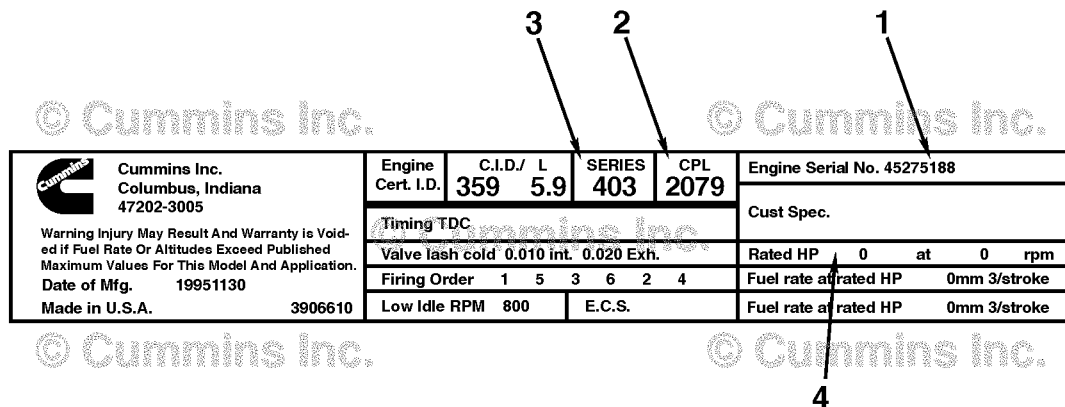

Have the following engine data available when communicating with a Cummins® Authorized Repair Location. The information on the dataplate is **mandatory** when sourcing service parts.

NOTE: The engines covered by this manual are produced worldwide. The data plates used on engines can differ in appearance and location of information. The following illustrations show examples of common data plates used and the information contained on the data plate.



- 1 Engine serial number
- 2 Control parts list (CPL)
- 3 Model
- 4 Horsepower and rpm rating.

00900061

 MADE IN GREAT BRITAIN BY CUMMINS INC. www.cummins.com		 <table border="1"> <tr> <td>24</td> <td>031408</td> <td>0.94</td> </tr> </table>	24	031408	0.94
24	031408	0.94			
Displacement..... 5.9 Litres Gross Power..... 184 kW @ 2500 rpm Valve lash - [cold] Int .254 mm, Exh .508 mm Low idle speed..... 600-800 rpm	E.C Type Approval Numbers e11*72/245*95/54*1413*00 (ESA) e11*88/77*2001/27A*1705*05 Model:- ISBE250 30				
Engine Serial No..... 1631663 Date of Mfg..... 12-01-05 Customer Spec..... AENB068 DAF ID..... CE184C	Warning: Injury May Result And Warranty Is Voided If Fuel Rate Limit Or Altitudes Exceed Published Maximum Values For This Model And Application 3286647				

- 1 Engine serial number
- 2 Model
- 3 Horsepower and rpm rating.

00d00181

NOTE: If the engine dataplate (1) is **not** readable, the engine serial number (2) can be identified on the engine block on top of the lubricating oil cooler housing. Additional engine information is available by reading the ECM dataplate.

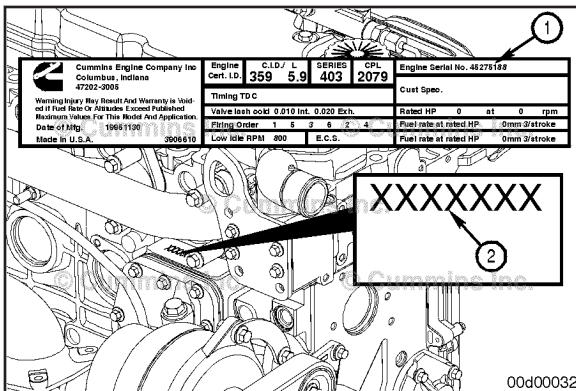

00d00032

Marine Applications

The engine dataplate provides important information about the engine. The engine serial number (ESN) and control part list (CPL) provide information for service and for ordering parts. The engine dataplate **must not** be changed unless approved by Cummins Inc.

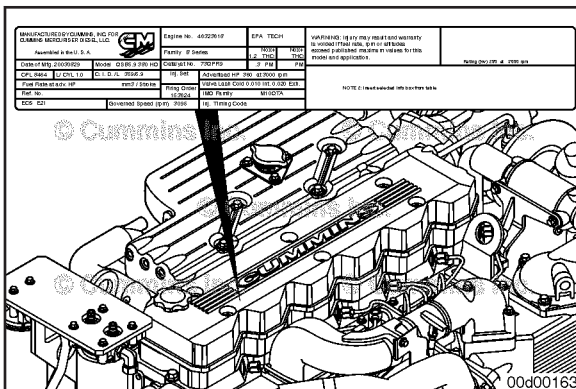

00d00163

MANUFACTURED BY CUMMINS, INC. FOR CUMMINS MERCURIDER DIESEL, L.L.C.		Engine No. 46323618	EPA TECH		WARNING: Injury may result and warranty is voided if fuel rate, rpm or altitudes exceed published maximum values for this model and application.
Assembled in the U. S. A.		Family B Series	Nox+ 2	Nox+ THC	
Date of Mfg. 20030829	Model QSB5.9 380 HO	Catalyst No. 73QPR9	3	PM	Rating (kw) 280 at 3000 rpm
CPL B494	L/ CYL 1.0	C. I. D./L 359/5.9	Inj. Set	Advised HP 360 at 3000 rpm	
Fuel Rate at adv. HP	mm ³ / Stroke	Firing Order 153624	Valve Lash Cold 0.010 Int. 0.020 Exh.		NOTE 2: Insert selected into box from table
Ref. No.		IMO Family M10GTA	Inj. Timing Code		
ECS E21	Governed Speed (rpm) 3095				

00d00164

Have the following engine data available when communicating with a Cummins Authorized Repair Location:

- 1 Control parts list (CPL)
- 2 Model
- 3 Engine serial number (ESN)
- 4 Horsepower and rpm rating.

NOTE: Depending on the manufacturing plant, calibration data may also be found on the engine dataplate.

Cummins® Engine Nomenclature

All Applications Except Marine

The Cummins® engine nomenclature provides the data as illustrated in the graphic.

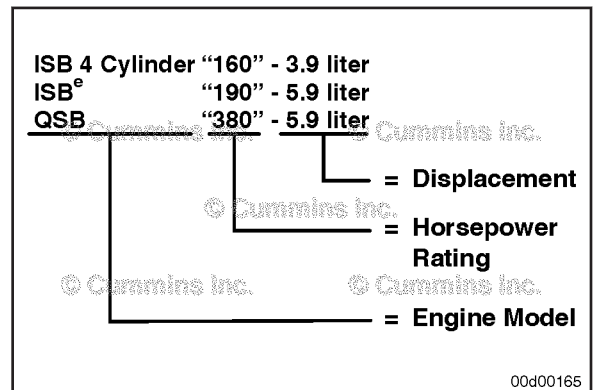

Marine Applications

The Cummins MerCruiser Diesel engine nomenclature provides the engine model, displacement in liters and horsepower rating.

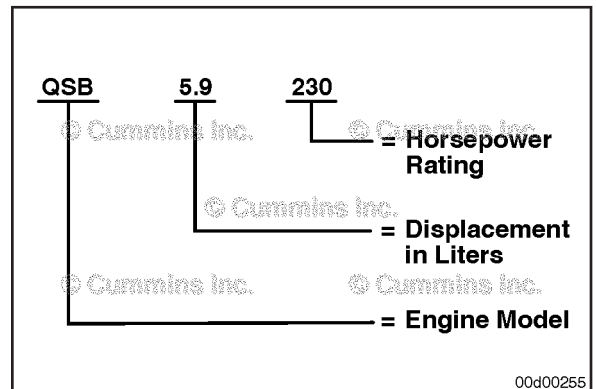

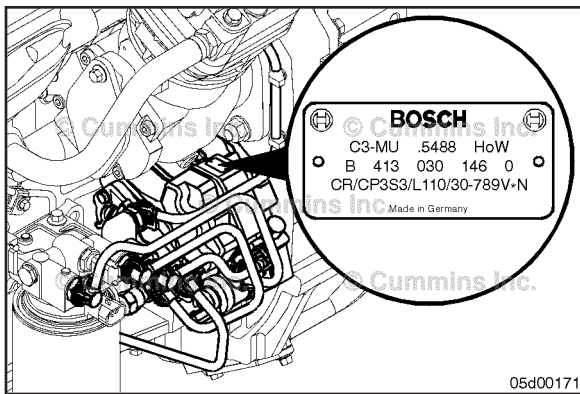

Fuel Injection Pump Dataplate

The Bosch® fuel injection pump dataplate is located on the fuel pump. The dataplate contains the following information:

- Pump serial number
- Cummins part number
- Factory code
- Bosch® part number
- Date code.

ECM Dataplate Automotive and Industrial

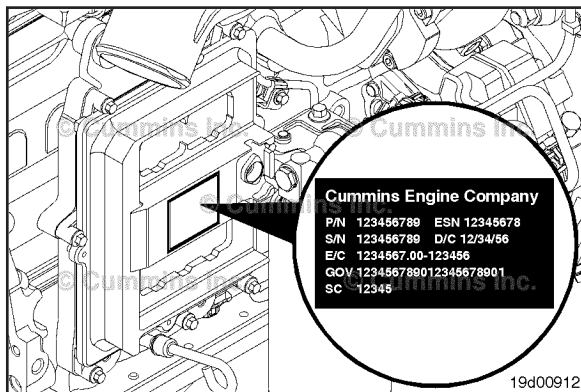

CM800 Electronic Control Module

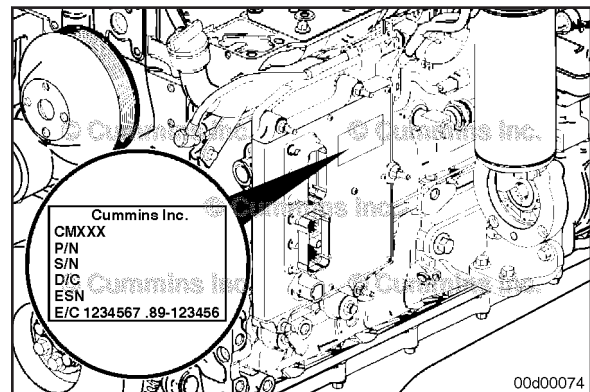

CM840/CM850/CM2100 Electronic Control Module

The electronic control module (ECM) dataplate shows information about the ECM and how the ECM was programmed. The dataplate is located on the ECM.

The following information is available on the ECM dataplate:

- ECM part number (PN)
- ECM serial number (SN)
- ECM date code (DC)
- Engine serial number (ESN)
- ECM code: Identifies the software in the ECM.

NOTE: Have the ECM code for your engine available when communicating with a Cummins® Authorized Repair Location.

NOTE: The presence of an ECM dataplate depends on the manufacturing plant and the date the engine was manufactured. If an ECM dataplate was **not** installed by the manufacturing plant, calibration data can be found on the engine dataplate.

Marine Applications

The electronic control module (ECM) dataplate shows information about the ECM and how the ECM was programmed. The dataplate is located on the ECM.

The following information is available on the ECM dataplate:

- ECM part number (P/N)
- ECM serial number (S/N)
- ECM date code (D/C)
- Engine serial number (ESN)
- ECM Code (identifies the software in the E/C).

NOTE: Have the ECM code for your engine available when communicating with a Cummins® Authorized Repair Location.

NOTE: The presence of an ECM dataplate depends on the manufacturing plant and the date the engine was manufactured. If an ECM dataplate was **not** installed by the manufacturing plant, calibration data can be found on the engine dataplate.

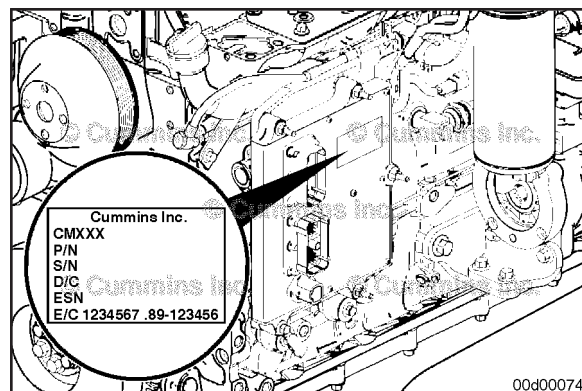

Engine Diagrams

Engine Views

The following illustrations show the locations of the major external engine components, filters, and other service and maintenance points. Some external components will be at different locations for different engine models.

NOTE: The illustrations are **only** a reference to show a typical engine.

Engine Diagrams

Engine Views

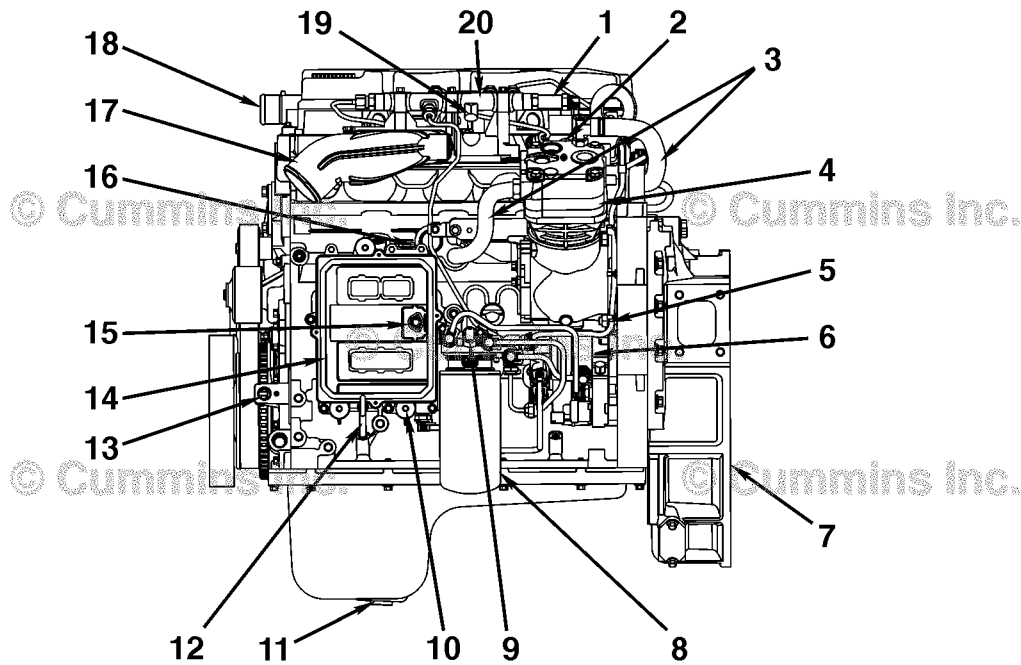

3.9 Liter Engine Air Intake Side View

00d00034

- 1 Rail pressure relief valve
- 2 Intake manifold pressure/temperature sensor
- 3 Air compressor cooling pipes
- 4 Air compressor
- 5 Engine position sensor (camshaft)
- 6 Bosch® fuel pump
- 7 Flywheel housing
- 8 Fuel filter
- 9 Fuel temperature sensor
- 10 Electronic control module cooling plate mounting points
- 11 Oil pan drain plug
- 12 Dipstick
- 13 Engine speed sensor (crankshaft)
- 14 Electronic control module (ECM)
- 15 Ambient air pressure sensor (internal to ECM)
- 16 Fuel inlet to cooling plate
- 17 Air intake inlet
- 18 Coolant outlet
- 19 Rail pressure sensor
- 20 Fuel rail.

Engine Diagrams

Engine Views

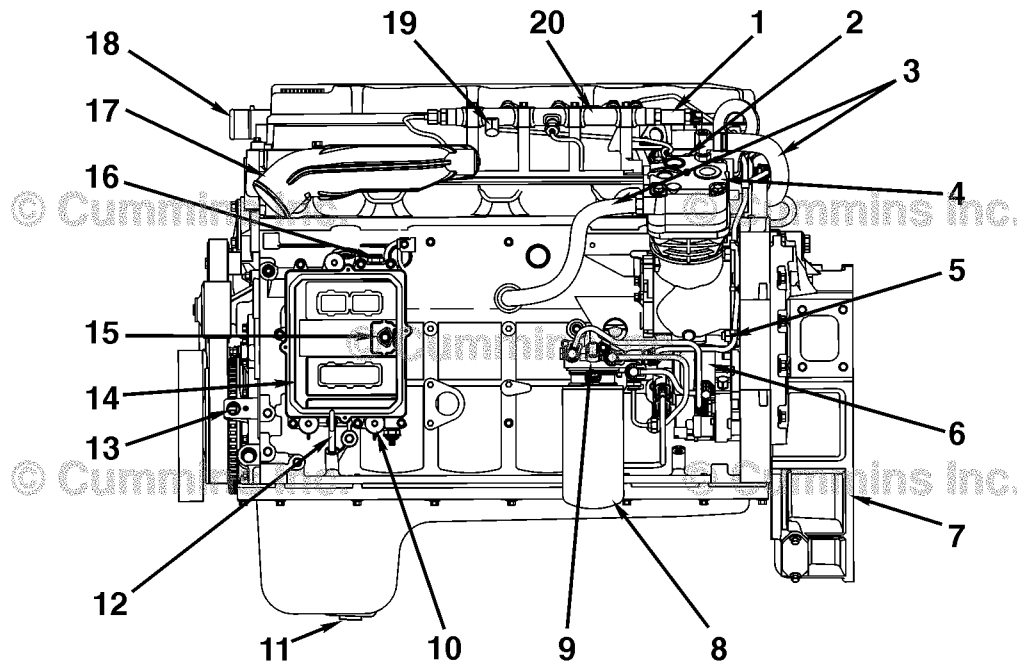

5.9 Liter Engine Air Intake Side View

00d00035

- 1 Rail pressure relief valve
- 2 Intake manifold pressure/temperature sensor
- 3 Air compressor cooling pipes
- 4 Air compressor
- 5 Engine position sensor (camshaft)
- 6 Bosch® fuel pump
- 7 Flywheel housing
- 8 Fuel filter
- 9 Fuel temperature sensor
- 10 Electronic control module cooling plate mounting points
- 11 Oil pan drain plug
- 12 Dipstick
- 13 Engine speed sensor (crankshaft)
- 14 Electronic control module (ECM)
- 15 Ambient air pressure sensor (internal to ECM)
- 16 Fuel inlet to cooling plate
- 17 Air intake inlet
- 18 Coolant outlet
- 19 Rail pressure sensor
- 20 Fuel rail.

Engine Diagrams

Engine Views

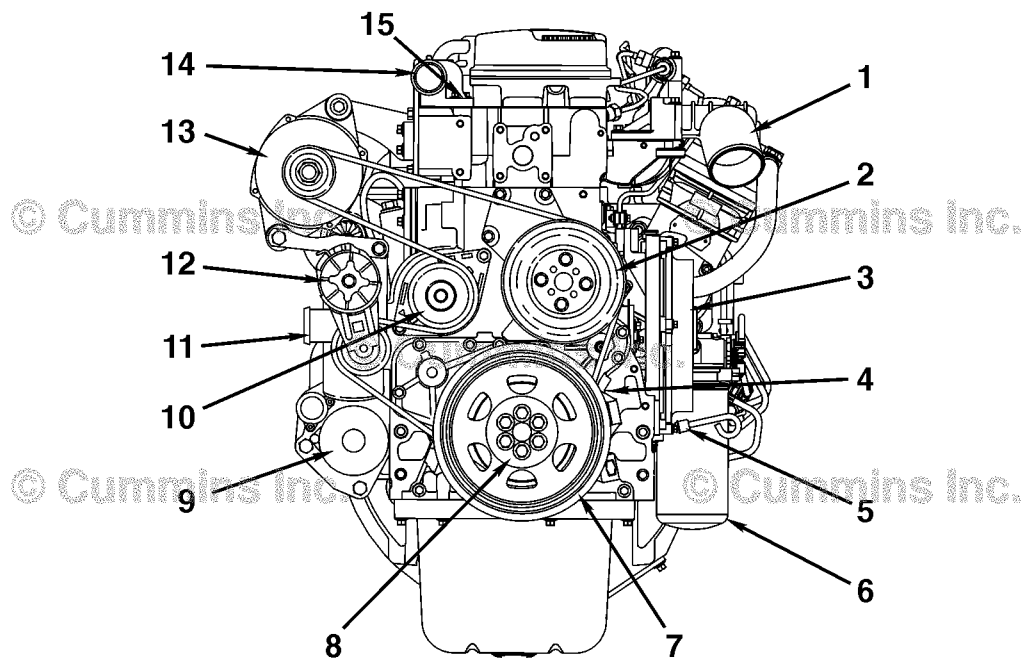

3.9 Liter Engine Front View

00d00040

- 1 Air inlet
- 2 Fan drive
- 3 Electronic control module (ECM)
- 4 Engine speed sensor (crankshaft)
- 5 Dipstick
- 6 Fuel filter
- 7 Vibration damper
- 8 Fan or PTO drive flange mounting
- 9 Starter
- 10 Water pump
- 11 Coolant inlet
- 12 Belt tensioner
- 13 Alternator
- 14 Coolant outlet
- 15 Coolant temperature sensor.

Engine Diagrams

Engine Views

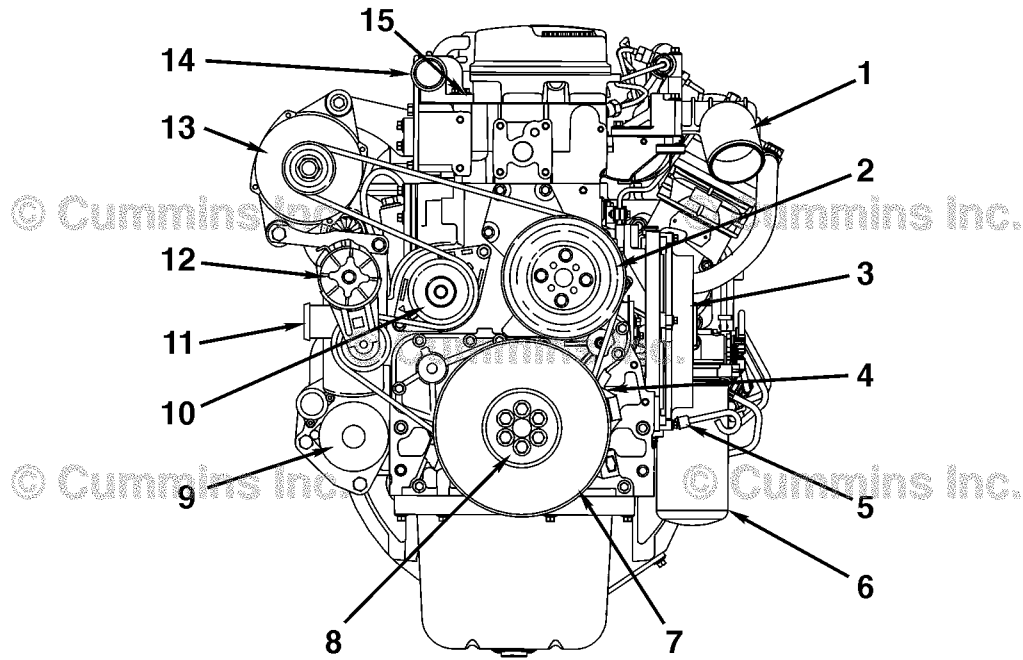

5.9 Liter Engine Front View

00d00041

- 1 Air inlet
- 2 Fan drive
- 3 Electronic control module (ECM)
- 4 Engine speed sensor (crankshaft)
- 5 Dipstick
- 6 Fuel filter
- 7 Vibration damper
- 8 Fan or PTO drive flange mounting
- 9 Starter
- 10 Water pump
- 11 Coolant inlet
- 12 Belt tensioner
- 13 Alternator
- 14 Coolant outlet
- 15 Coolant temperature sensor.

Engine Diagrams

Engine Views

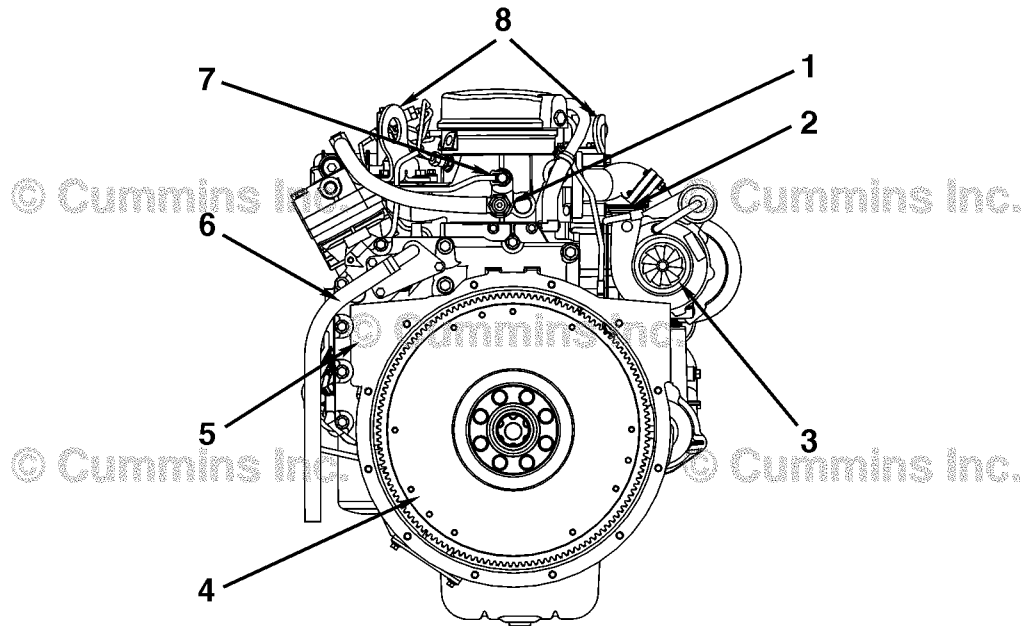

3.9 Liter Engine Rear View

00d00036

- 1 Coolant connection for air compressor
- 2 Air outlet from turbocharger
- 3 Air inlet to turbocharger
- 4 Flywheel
- 5 Flywheel housing
- 6 Crankcase breather tube
- 7 Fuel return line
- 8 Engine lifting brackets.

Engine Diagrams

Engine Views

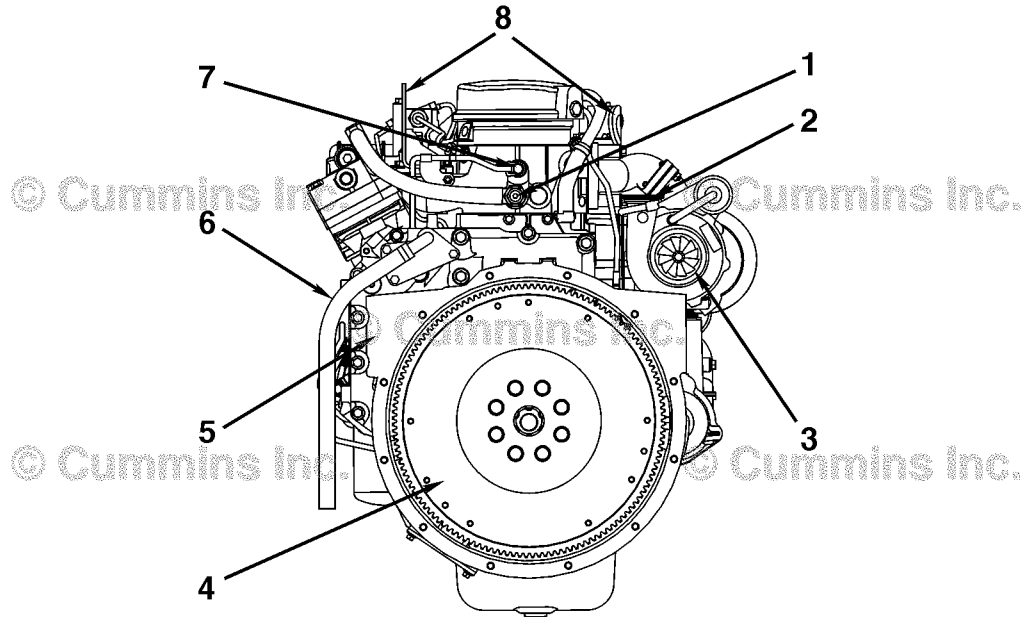

00d00037

5.9 Liter Engine Rear View

- 1 Coolant connection for air compressor
- 2 Air outlet from turbocharger
- 3 Air inlet to turbocharger
- 4 Flywheel
- 5 Flywheel housing
- 6 Crankcase breather tube
- 7 Fuel return line
- 8 Engine lifting brackets.

Engine Diagrams

Engine Views

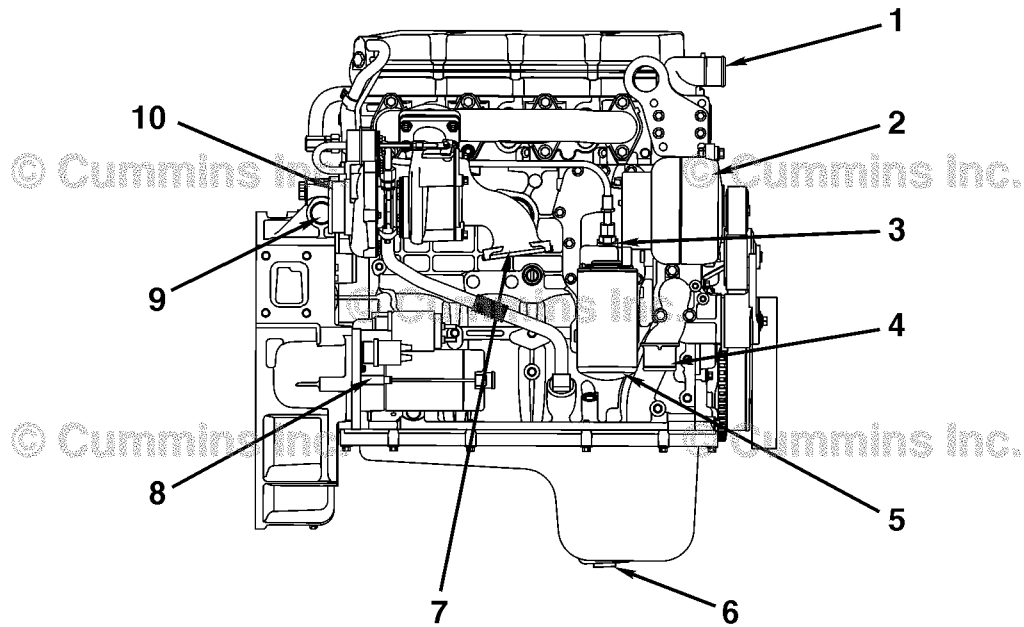

3.9 Liter Engine Exhaust Side View

00d00038

- 1 Coolant outlet
- 2 Alternator
- 3 Oil pressure/temperature sensor
- 4 Coolant inlet
- 5 Oil filter
- 6 Oil pan drain plug
- 7 Turbocharger exhaust outlet
- 8 Starter
- 9 Flywheel housing
- 10 Turbocharger compressor inlet.

Engine Diagrams

Engine Views

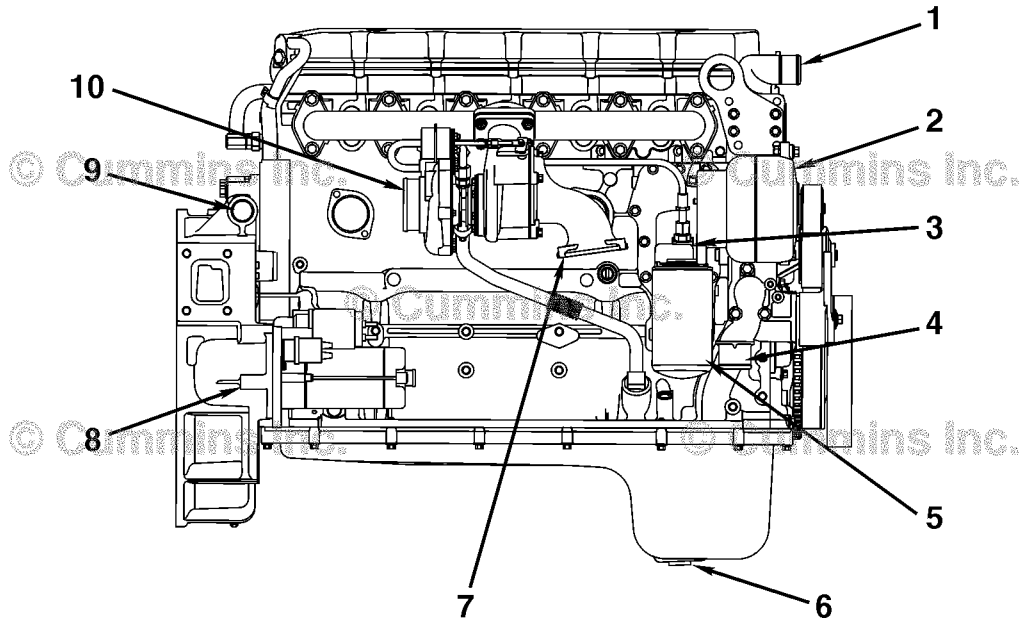

5.9 Liter Engine Exhaust Side View

00d00039

- 1 Coolant outlet
- 2 Alternator
- 3 Oil pressure/temperature sensor
- 4 Coolant inlet
- 5 Oil filter
- 6 Oil pan drain plug
- 7 Turbocharger exhaust outlet
- 8 Starter
- 9 Flywheel housing
- 10 Turbocharger compressor inlet.

Engine Diagrams

Engine Views

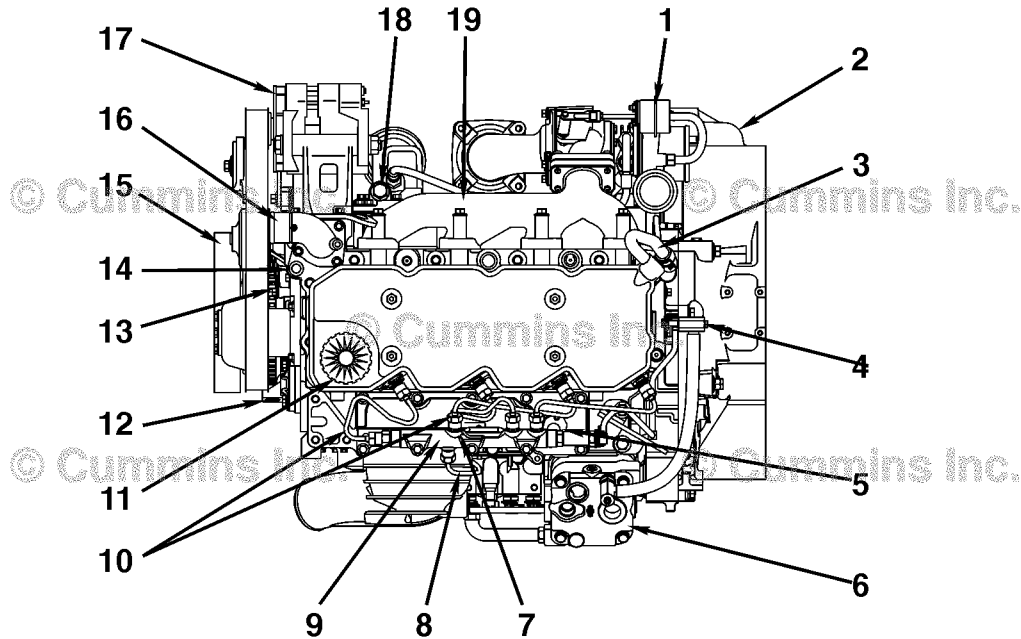

3.9 Liter Engine Top View

00d00042

- 1 Turbocharger wastegate actuator
- 2 Flywheel housing
- 3 Crankcase breather
- 4 Air compressor coolant connection
- 5 Intake manifold pressure/temperature sensor
- 6 Air compressor
- 7 Fuel rail
- 8 High-pressure supply line (pump to rail)
- 9 Fuel rail pressure sensor
- 10 High-pressure fuel lines
- 11 Oil fill cap
- 12 Engine speed sensor (crankshaft)
- 13 Tone wheel
- 14 Coolant temperature sensor
- 15 Vibration damper
- 16 Coolant outlet
- 17 Alternator
- 18 Oil pressure/temperature sensor
- 19 Exhaust manifold.

Engine Diagrams

Engine Views

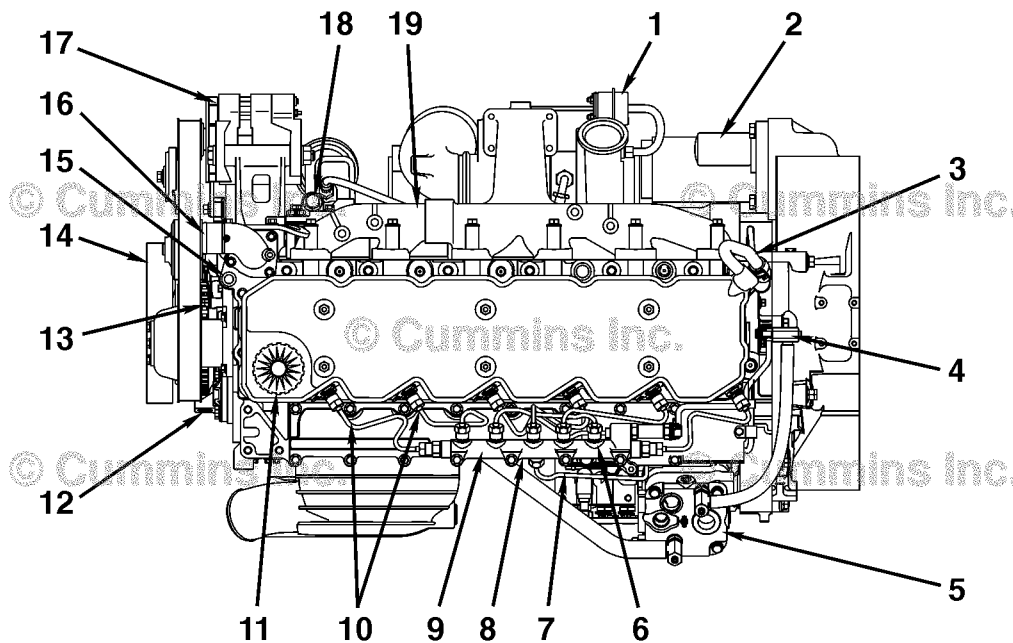

5.9 Liter Engine Top View

00d00043

- 1 Turbocharger wastegate actuator
- 2 Starter
- 3 Crankcase breather
- 4 Air compressor coolant connection
- 5 Air compressor
- 6 Intake manifold pressure/temperature sensor
- 7 High-pressure supply line (pump to rail)
- 8 Fuel rail pressure sensor
- 9 Fuel rail
- 10 High-pressure fuel lines
- 11 Oil fill cap
- 12 Engine speed sensor (crankshaft)
- 13 Tone wheel
- 14 Vibration damper
- 15 Coolant temperature sensor
- 16 Coolant outlet
- 17 Alternator
- 18 Oil pressure/temperature sensor
- 19 Exhaust manifold.

Engine Diagrams

Engine Views

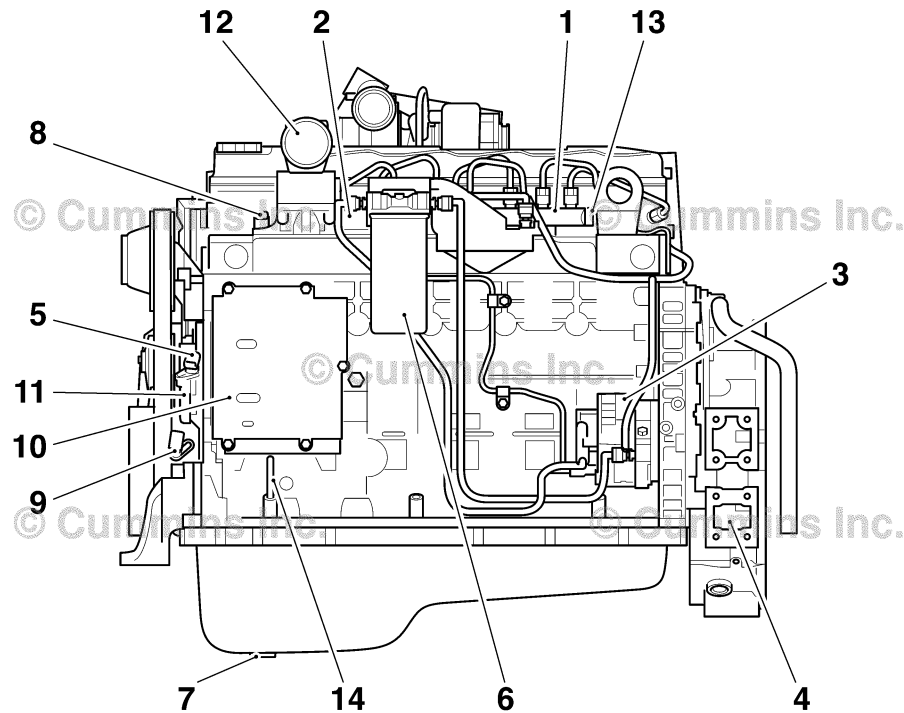

00d00184

QSB 6.7 Engine Air Intake Side View

- 1 Fuel rail
- 2 Intake pressure and temperature sensor
- 3 Bosch® fuel pump
- 4 Flywheel housing
- 5 Oil pressure switch
- 6 Fuel filter
- 7 Oil pan drain plug
- 8 Barometric pressure sensor
- 9 Engine speed sensor (crankshaft)
- 10 Electronic control module (ECM)
- 11 Engine position sensor (camshaft)
- 12 Air intake inlet
- 13 Rail pressure sensor
- 14 Dipstick

Engine Diagrams

Engine Views

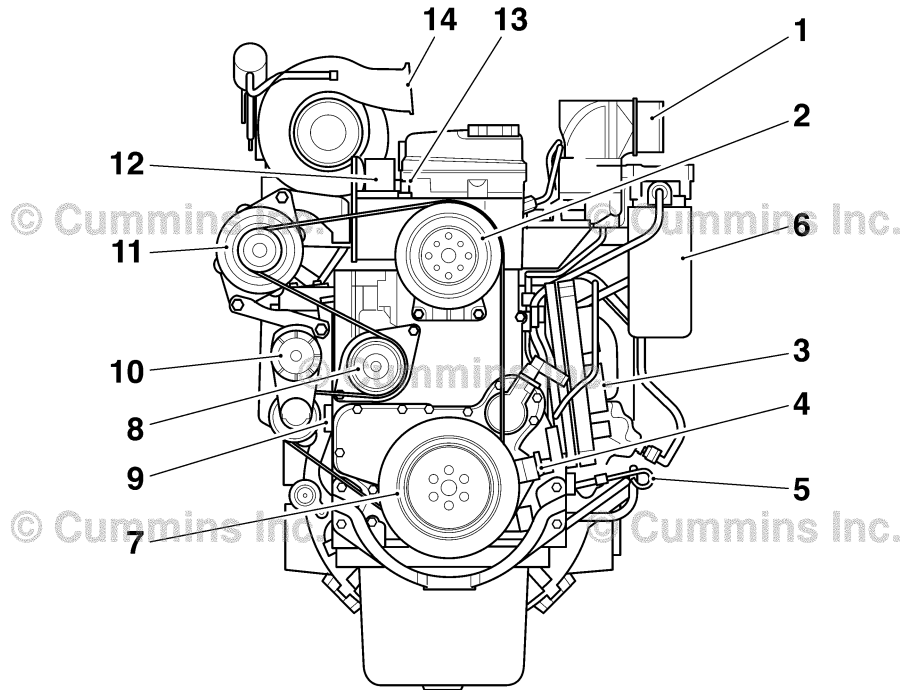

00d00185

QSB6.7 Engine Front View

- 1 Air inlet
- 2 Fan drive
- 3 Electronic control module (ECM)
- 4 Engine speed sensor (crankshaft)
- 5 Dipstick
- 6 Fuel filter
- 7 Vibration damper
- 8 Water pump
- 9 Starter
- 10 Belt tensioner
- 11 Alternator
- 12 Coolant outlet
- 13 Coolant temperature sensor
- 14 Turbocharger air outlet

Engine Diagrams

Engine Views

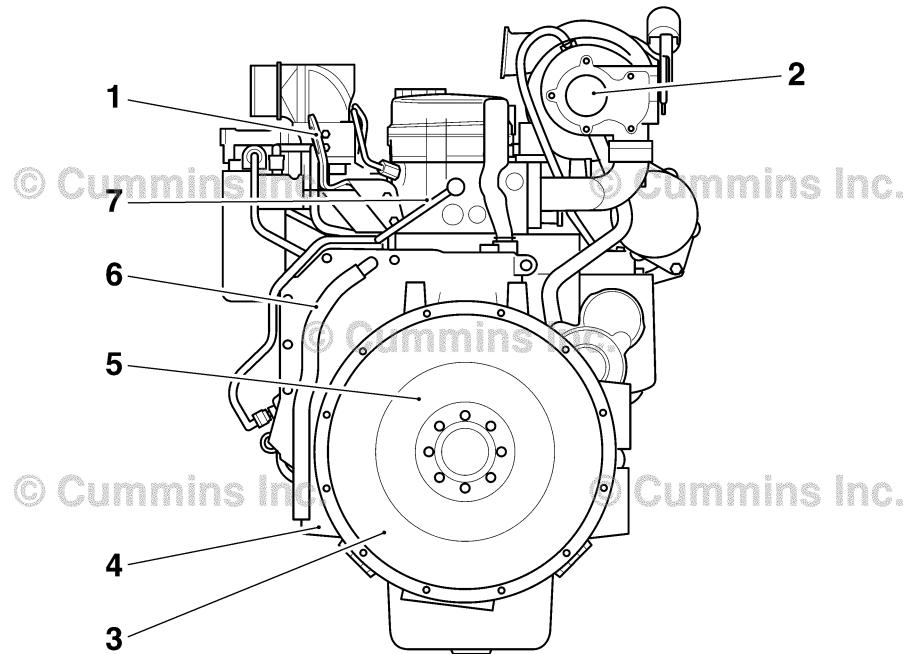

00d00187

QSB6.7 Engine Rear View

- 1 Rear engine lifting bracket
- 2 Turbocharger exhaust outlet
- 3 Clutch mounting holes
- 4 Flywheel housing
- 5 Flywheel/flexplate
- 6 Crankcase breather tube
- 7 Injector drain line

Engine Diagrams

Engine Views

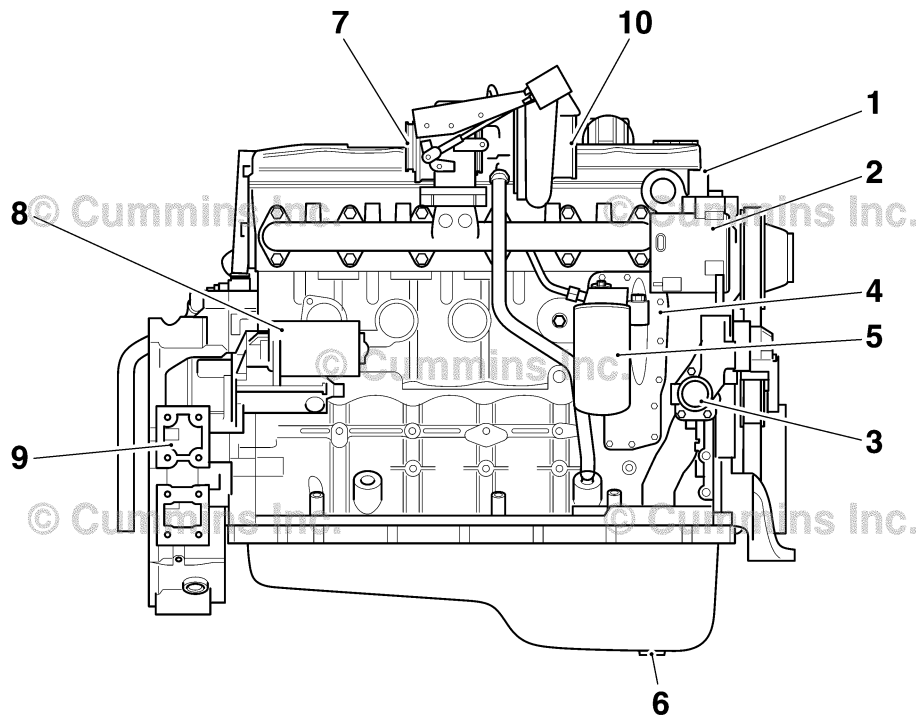

00d00186

QSB6.7 Engine Exhaust Side View

- 1 Coolant outlet
- 2 Alternator
- 3 Coolant inlet
- 4 Lubricating oil cooler
- 5 Oil filter
- 6 Oil pan drain plug
- 7 Turbocharger exhaust outlet
- 8 Starter
- 9 Flywheel housing
- 10 Turbocharger compressor inlet.

Engine Diagrams

Engine Views

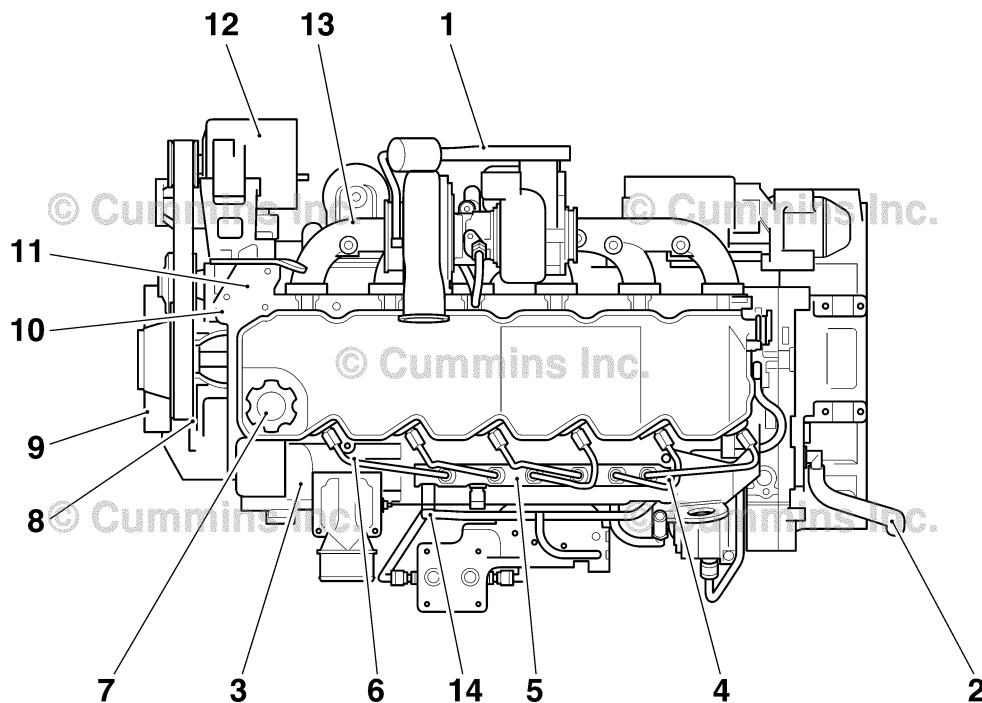

00d00183

QSB 6.7 Engine Top View

- 1 Turbocharger wastegate
- 2 Crankcase breather
- 3 Barometric pressure/temperature sensor
- 4 Fuel rail pressure sensor
- 5 Fuel rail
- 6 High-pressure fuel lines
- 7 Oil fill cap
- 8 Tone wheel
- 9 Vibration damper
- 10 Coolant temperature sensor
- 11 Coolant outlet
- 12 Alternator
- 13 Exhaust manifold
- 14 Rail pressure relief valve

Engine Diagrams

Engine Views

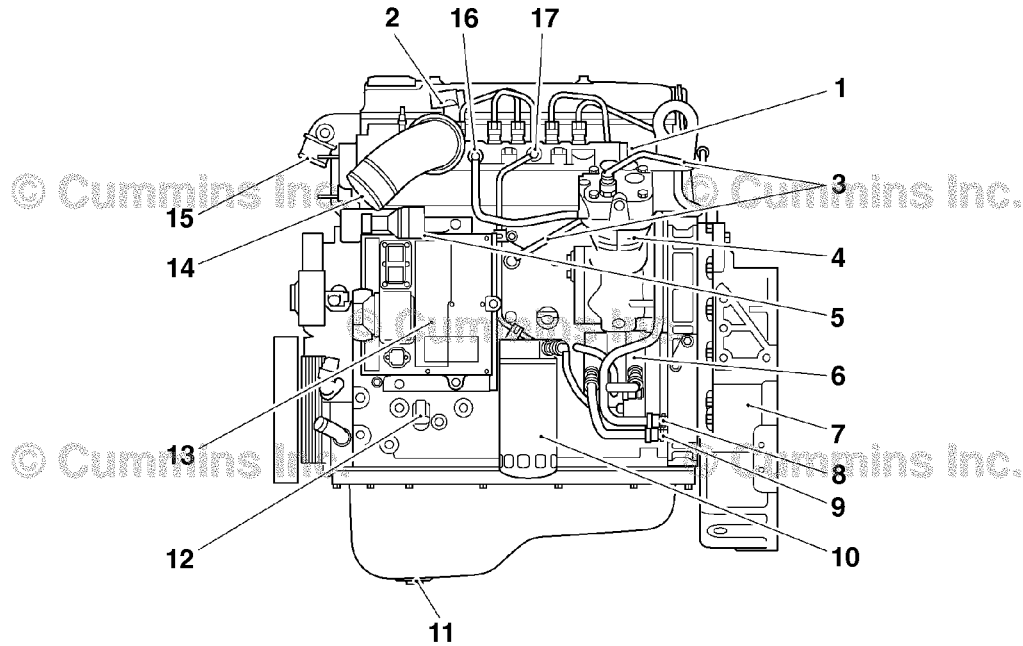

QSB4.5 Engine Air Intake Side View

00d00253

- 1 Fuel rail pressure sensor
- 2 Intake manifold pressure/temperature sensor
- 3 Air compressor cooling pipes
- 4 Air compressor
- 5 Ambient air pressure sensor
- 6 Bosch® fuel pump
- 7 Flywheel housing
- 8 Fuel return
- 9 Fuel inlet
- 10 Fuel filter
- 11 Oil pan drain plug
- 12 Dipstick/oil level sensor
- 13 Electronic control module (ECM)
- 14 Air intake inlet
- 15 Coolant outlet
- 16 Fuel rail pressure relief valve
- 17 Fuel rail.

Engine Diagrams

Engine Views

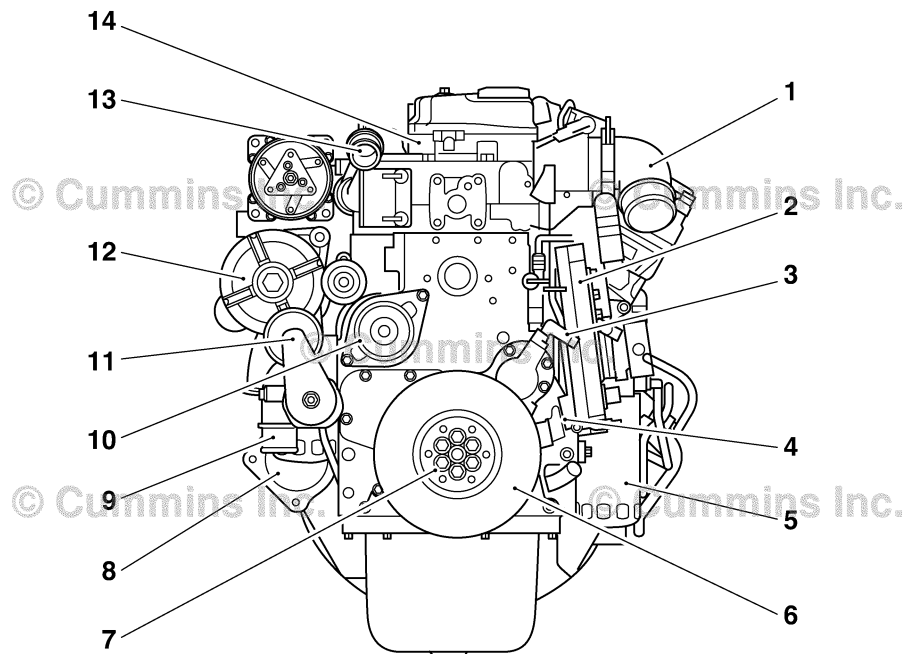

00d00215

QSB4.5 Engine Front View

- 1 Air inlet
- 2 Electronic control module (ECM)
- 3 Engine speed sensor (camshaft)
- 4 Engine speed sensor (crankshaft)
- 5 Fuel filter
- 6 Vibration damper (Optional)
- 7 Fan or PTO drive flange mounting
- 8 Starter mounting location
- 9 Coolant inlet
- 10 Water pump
- 11 Belt tensioner
- 12 Alternator
- 13 Coolant outlet
- 14 Coolant temperature sensor.

Engine Diagrams

Engine Views

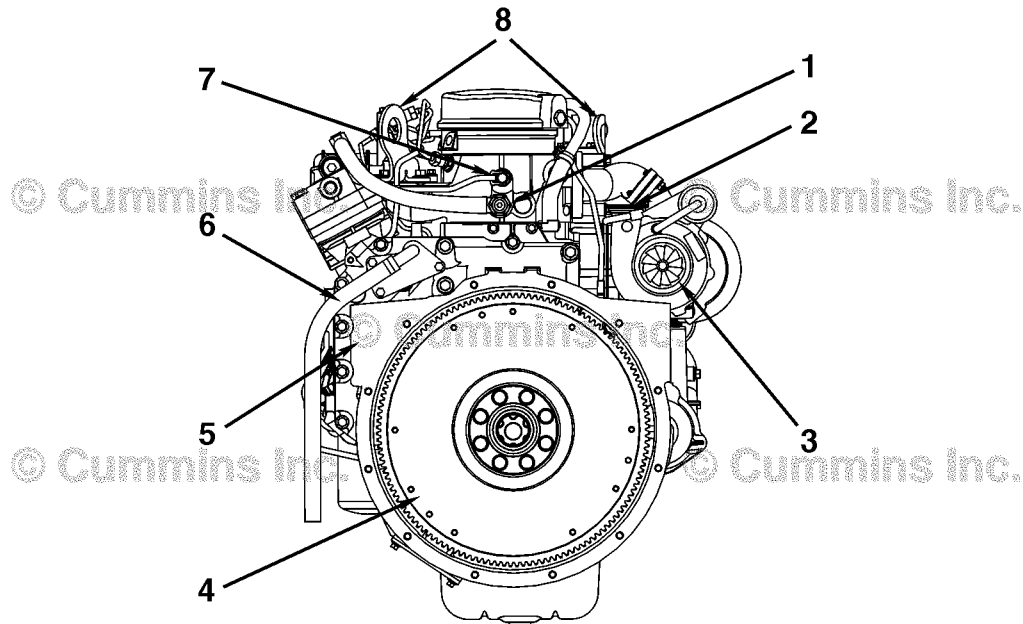

00d00036

QSB4.5 Engine Rear View

- 1 Coolant connection for air compressor
- 2 Air outlet from turbocharger
- 3 Air inlet to turbocharger
- 4 Flywheel
- 5 Flywheel housing
- 6 Crankcase breather tube
- 7 Fuel return line
- 8 Engine lifting brackets.

Engine Diagrams

Engine Views

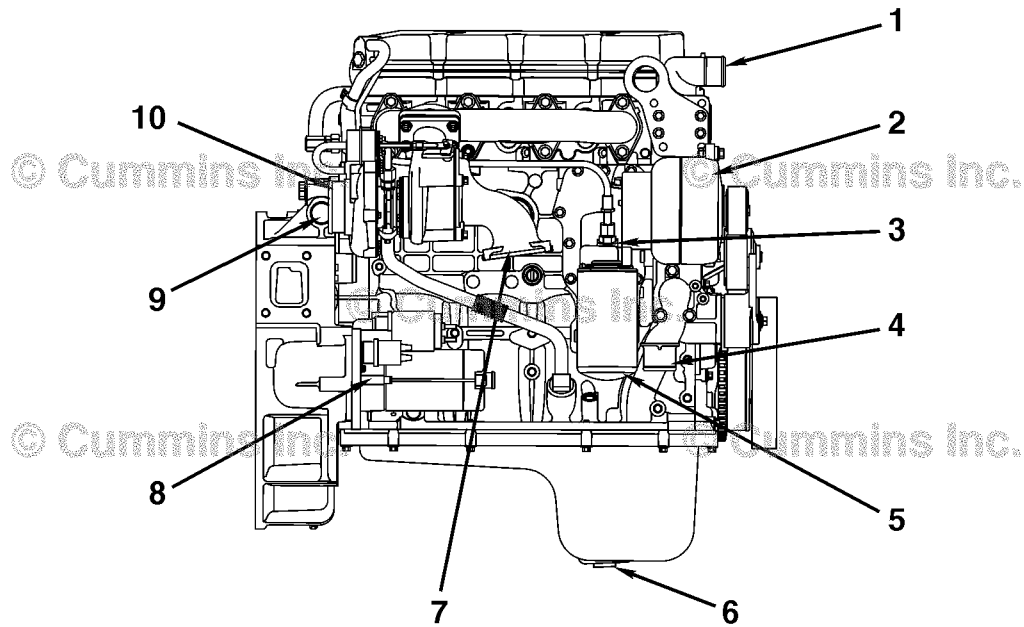

QSB4.5 Engine Exhaust Side View

00d00038

- 1 Coolant outlet
- 2 Alternator
- 3 Oil cooler
- 4 Coolant inlet
- 5 Oil filter
- 6 Oil pan drain plug
- 7 Turbocharger exhaust outlet
- 8 Starter
- 9 Flywheel housing
- 10 Turbocharger compressor inlet.

Engine Diagrams

Engine Views

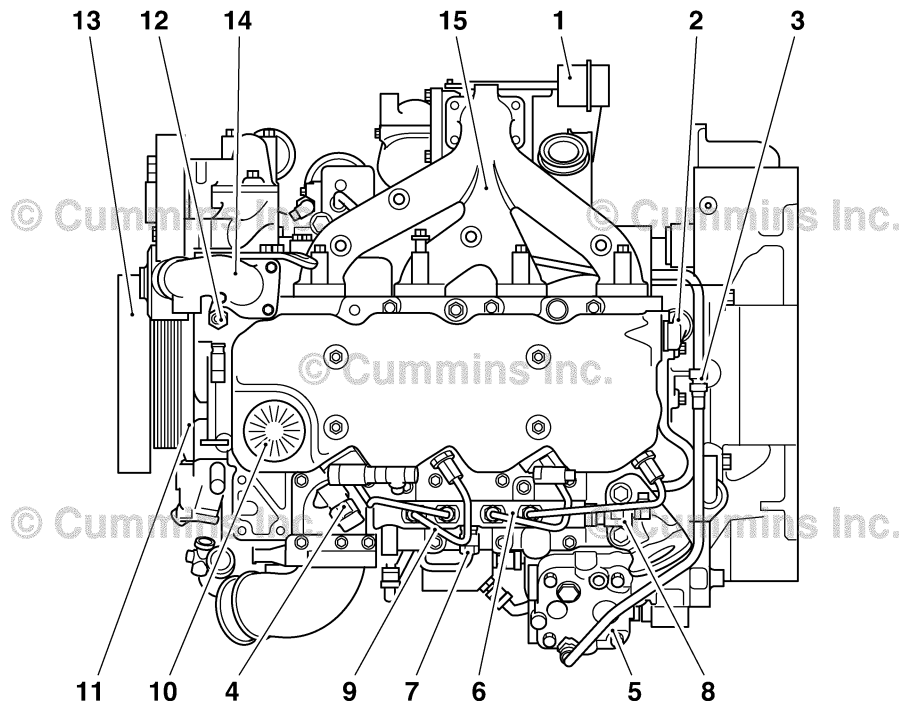

00d00217

QSB4.5 Engine Top View

- 1 Turbocharger wastegate actuator
- 2 Crankcase breather
- 3 Air compressor coolant connection
- 4 Intake manifold pressure/temperature sensor
- 5 Air compressor
- 6 Fuel rail
- 7 High-pressure supply line (pump to rail)
- 8 Fuel rail pressure sensor
- 9 High-pressure fuel lines
- 10 Oil fill cap
- 11 Tone wheel
- 12 Coolant temperature sensor
- 13 Vibration damper (Optional)
- 14 Coolant outlet
- 15 Exhaust manifold.

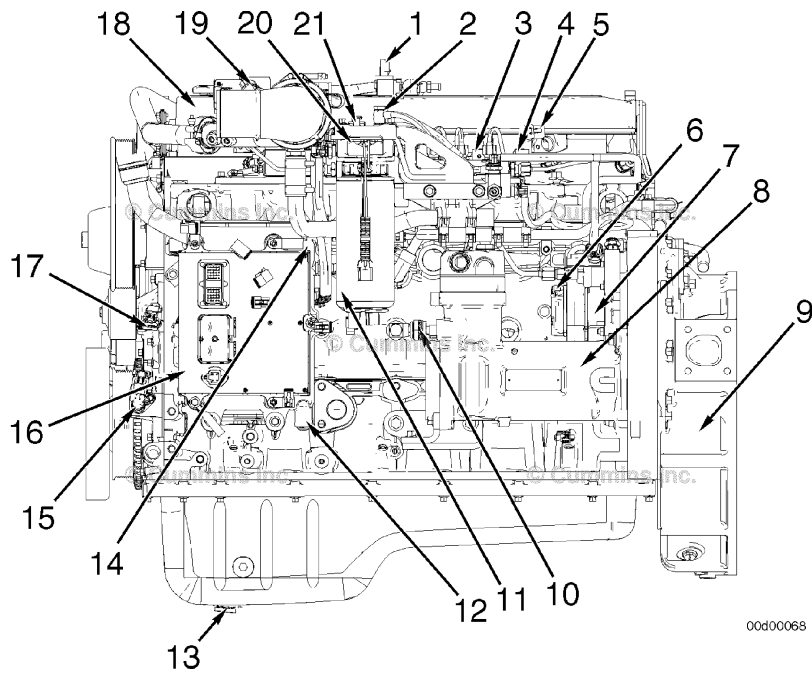

ISB CM850, 5.9 Liter Engine Intake Side View (with EGR)

- 1 Exhaust pressure sensor
- 2 Rail pressure relief valve
- 3 Fuel rail
- 4 Intake manifold pressure sensor
- 5 Intake temperature sensor
- 6 Electronic fuel control (EFC) actuator
- 7 Bosch® fuel pump
- 8 Air compressor
- 9 Flywheel housing
- 10 Oil pressure switch
- 11 Fuel filter
- 12 Fuel inlet to cooling plate
- 13 Oil pan drain plug
- 14 Barometric pressure sensor
- 15 Engine speed sensor (crankshaft)
- 16 Electronic control module (ECM)
- 17 Engine speed sensor (camshaft)
- 18 Air intake inlet
- 19 EGR temperature sensor
- 20 Fuel heater
- 21 Rail pressure sensor.

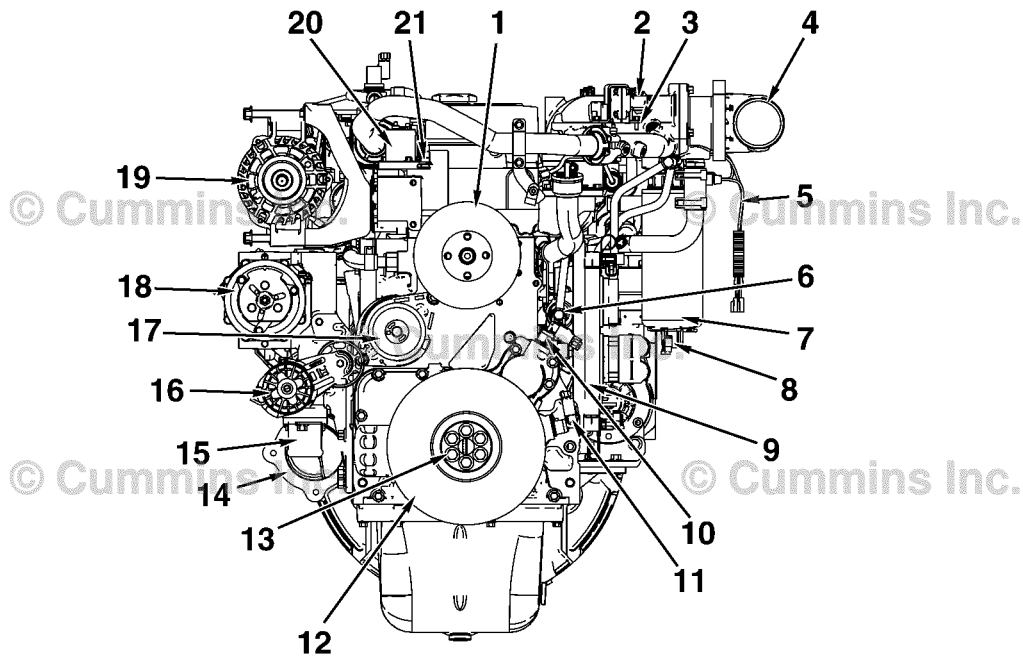

ISB CM850, 5.9 Liter Engine Front View (with EGR)

00d00069

- 1 Fan drive
- 2 EGR differential pressure sensor
- 3 EGR temperature sensor
- 4 Air inlet
- 5 Fuel heater
- 6 Fuel lift pump
- 7 Fuel filter
- 8 Water-in-fuel sensor
- 9 Electronic control module (ECM)
- 10 Engine speed sensor (camshaft)
- 11 Engine speed sensor (crankshaft)
- 12 Vibration damper
- 13 Fan or PTO drive flange mounting
- 14 Starter
- 15 Coolant inlet
- 16 Belt tensioner
- 17 Water pump
- 18 Freon compressor
- 19 Alternator
- 20 Coolant outlet
- 21 Coolant temperature sensor.

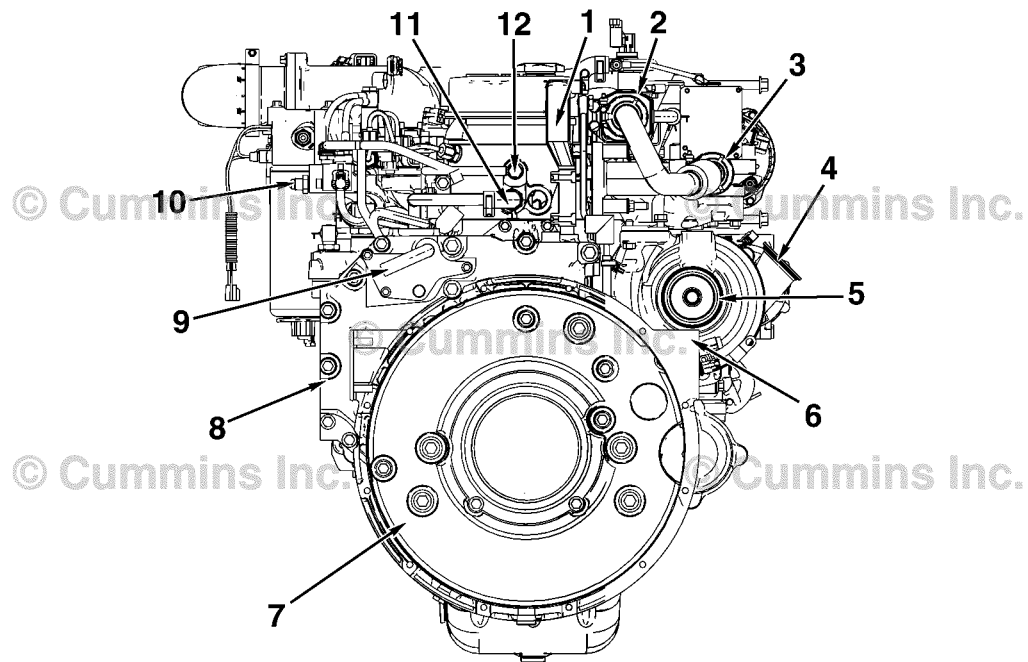

ISB CM850, 5.9 Liter Engine Rear View (with EGR)

00d00070

- 1 Breather tube (valve cover to gear housing)
- 2 EGR cooler
- 3 EGR valve
- 4 Air outlet from turbocharger
- 5 Turbocharger exhaust outlet
- 6 Flywheel housing
- 7 Flywheel
- 8 Gear housing
- 9 Crankcase breather
- 10 Fuel out (return to tank)
- 11 Coolant connection for air compressor
- 12 Fuel return line.

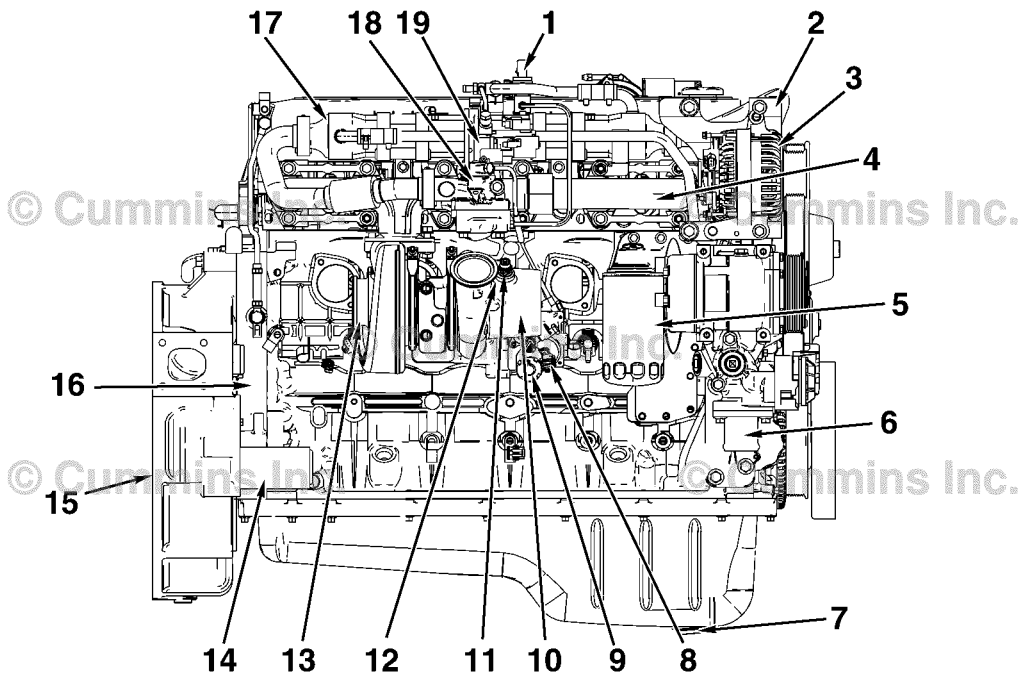

00d00071

ISB CM850, 5.9 Liter Engine Exhaust Side View (with EGR)

- 1 Exhaust pressure sensor
- 2 Coolant outlet
- 3 Alternator
- 4 Exhaust manifold
- 5 Oil filter
- 6 Coolant inlet
- 7 Oil pan drain plug
- 8 Turbocharger position sensor
- 9 Turbocharger actuator
- 10 Turbocharger compressor inlet
- 11 Compressor inlet temperature sensor
- 12 Turbocharger speed sensor
- 13 Turbocharger exhaust outlet
- 14 Starter
- 15 Flywheel housing
- 16 Gear housing
- 17 EGR cooler
- 18 EGR valve
- 19 EGR actuator.

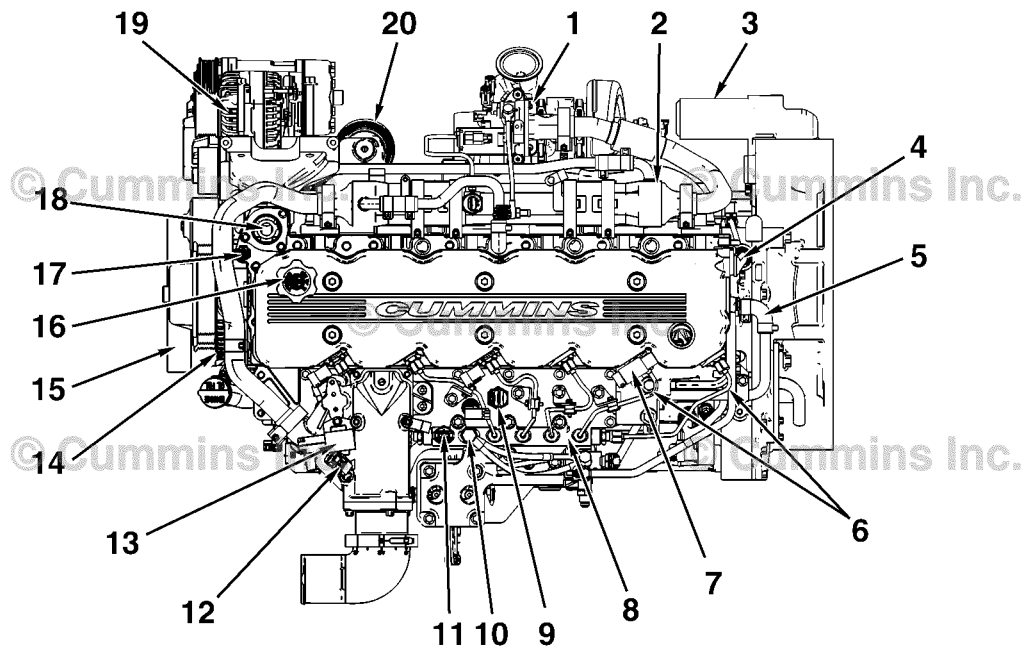

00d00072

ISB CM850, 5.9 Liter Engine Top View (with EGR)

- 1 EGR valve
- 2 EGR cooler
- 3 Starter
- 4 Breather tube (valve cover to gear housing)
- 5 Air compressor coolant connection
- 6 High-pressure fuel lines
- 7 Intake temperature sensor
- 8 Fuel rail
- 9 Intake manifold pressure sensor
- 10 Rail pressure relief valve
- 11 Fuel rail pressure sensor
- 12 EGR temperature sensor
- 13 EGR differential pressure sensor
- 14 Tone wheel
- 15 Vibration damper
- 16 Oil fill cap
- 17 Coolant temperature sensor
- 18 Coolant outlet
- 19 Alternator
- 20 Oil filter.

This Page Left Intentionally Blank

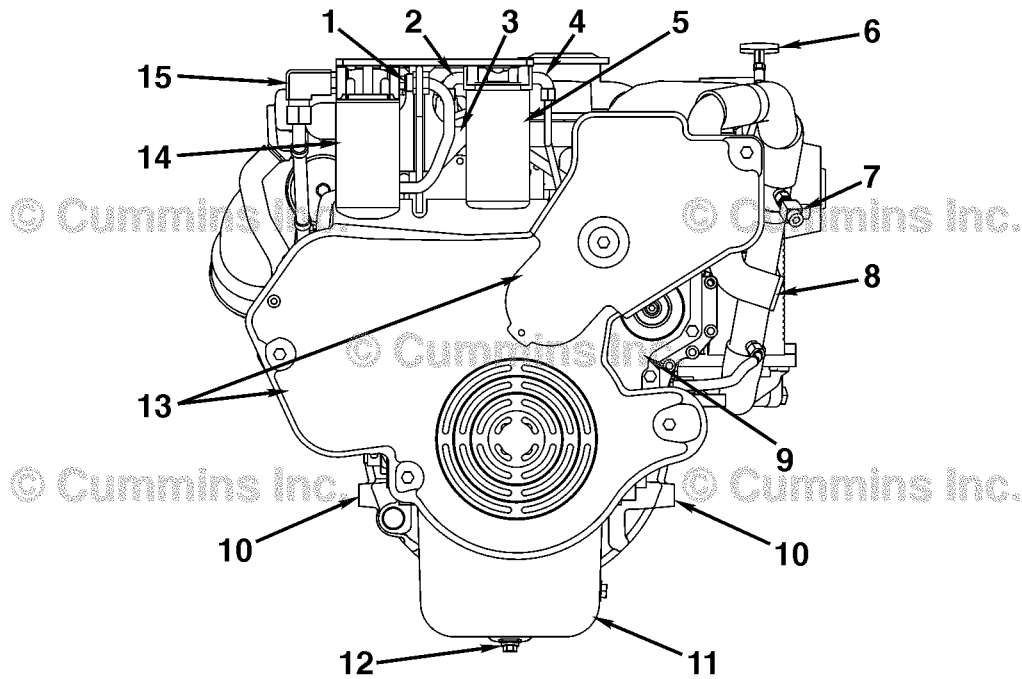

QSB CM850, 5.9 Liter Marine Engine (Front View)

00d00153

- 1 Lubricating oil filter head outlet
- 2 Fuel filter head outlet to high pressure fuel pump
- 3 Coolant temperature sensor
- 4 Fuel filter head inlet from lift pump
- 5 Fuel filter
- 6 Lubricating oil dipstick
- 7 Fuel return from fuel cooler to tank
- 8 Sea water pump inlet
- 9 Timing case cover
- 10 Mounting brackets
- 11 Oil pan
- 12 Lubricating oil drain
- 13 Belt and pulley guards
- 14 Lubricating oil filter
- 15 Lubricating oil filter head inlet.

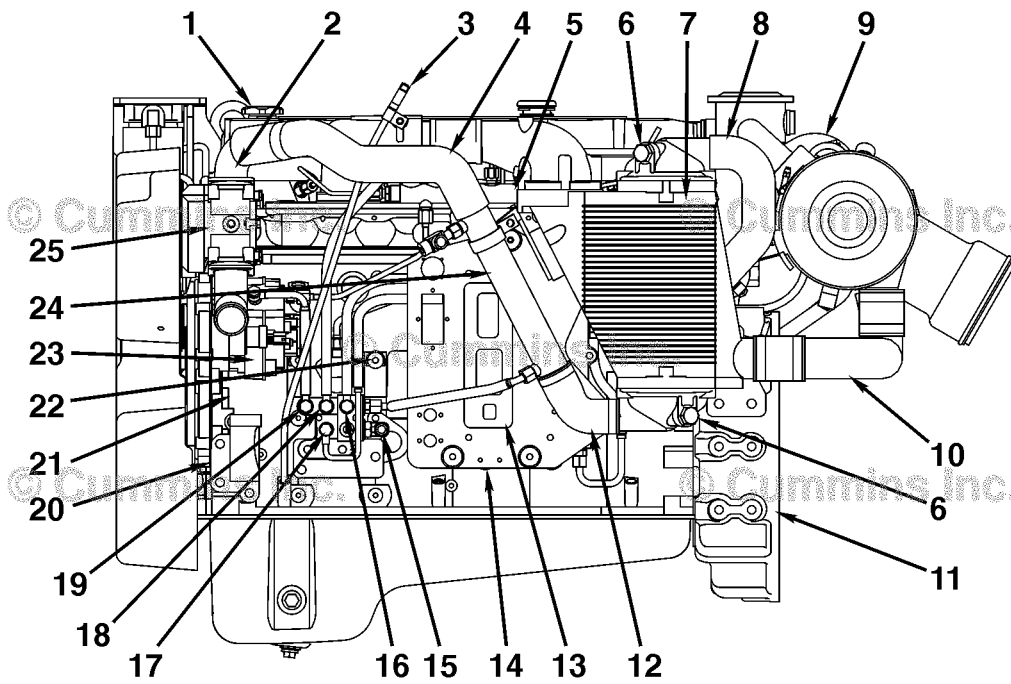

QSB CM850, 5.9 Liter Marine Engine (Port View)

00d00154

- 1 Engine oil fill
- 2 Sea water pump outlet
- 3 Lubricating oil level gauge
- 4 Sea water supply to fuel cooler
- 5 Intake manifold pressure and air temperature sensor
- 6 Aftercooler zinc anode (2)
- 7 Aftercooler housing
- 8 Aftercooler sea water outlet
- 9 Turbocharger
- 10 Aftercooler air inlet
- 11 Flywheel housing
- 12 Aftercooler sea water inlet
- 13 Electronic control module (ECM)
- 14 Fuel lift pump (behind ECM cooling plate)
- 15 Fuel inlet connection
- 16 Fuel return from injector
- 17 Fuel supply to lift pump
- 18 Fuel return from fuel rail pressure relief valve
- 19 Fuel return from high pressure fuel pump
- 20 Crankshaft speed sensor
- 21 Camshaft speed sensor
- 22 Oil pressure sensor
- 23 Fuel pump
- 24 Fuel cooler
- 25 Sea water pump.

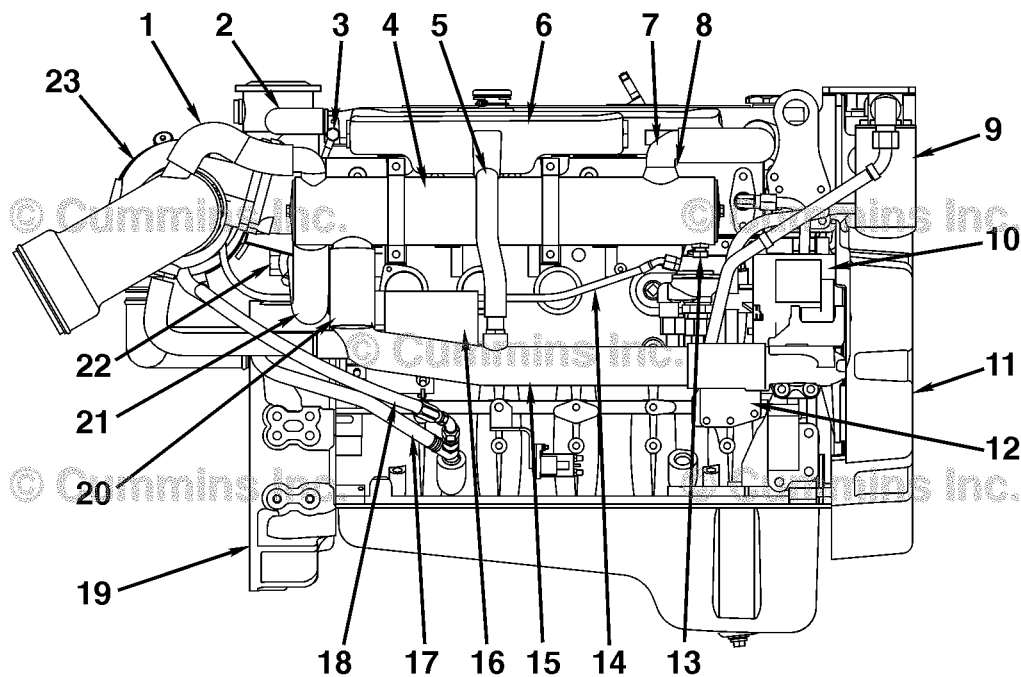

QSB CM850, 5.9 Liter Marine Engine (Starboard View)

00d00229

- 1 Sea water outlet
- 2 Closed crankcase breather system hose
- 3 Crankcase breather tube banjo connection
- 4 Heat exchanger
- 5 Engine coolant fill line
- 6 Expansion tank
- 7 Coolant level sensor
- 8 Heat exchanger engine coolant inlet
- 9 Lubricating oil filter
- 10 Alternator
- 11 Belt and pulley guard
- 12 Lubricating oil cooler
- 13 Zinc anode
- 14 Turbocharger oil supply line
- 15 Coolant return junction tube
- 16 Starting motor
- 17 Turbocharger oil drain line
- 18 Closed crankcase breather oil drain line
- 19 Flywheel housing
- 20 Heat exchanger engine coolant outlet
- 21 Heat exchanger sea water inlet
- 22 Marine gear oil cooler
- 23 Turbocharger

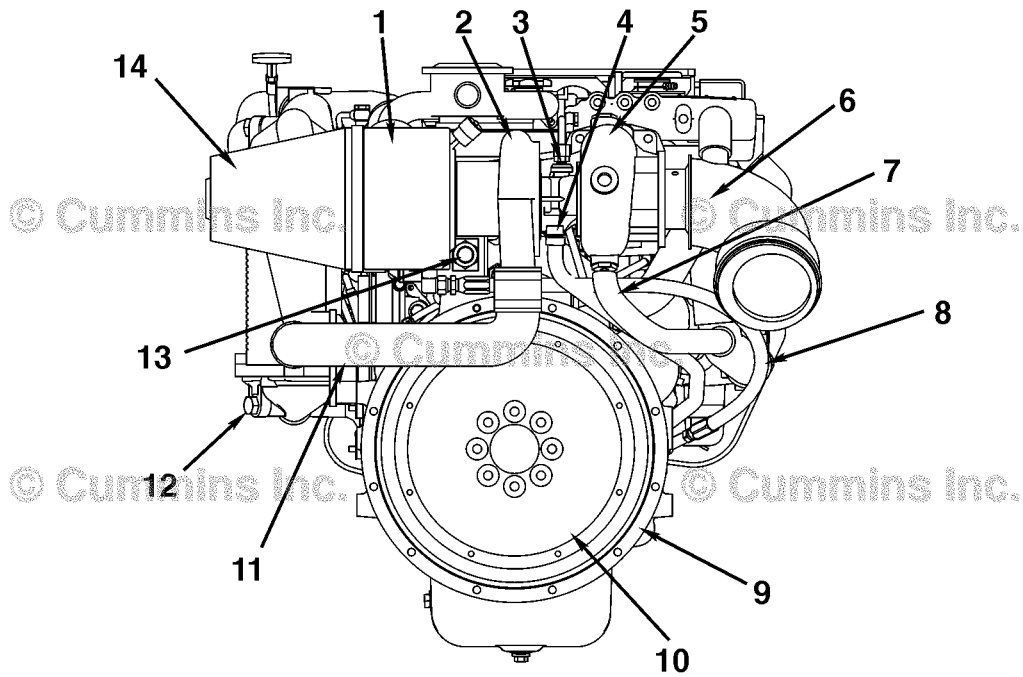

QSB CM850, 5.9 Liter Marine Engine (Rear View)

00d00156

- 1 Closed crankcase breather system
- 2 Turbocharger, compressor side
- 3 Turbocharger oil supply
- 4 Turbocharger oil drain
- 5 Turbocharger, turbine side
- 6 Heat exchanger (behind exhaust outlet)
- 7 Turbocharger coolant outlet
- 8 Closed crankcase breather oil drain tube
- 9 Flywheel housing
- 10 Flywheel
- 11 Aftercooler air inlet
- 12 Aftercooler zinc anode
- 13 Marine gear oil cooler
- 14 Air cleaner and filter.

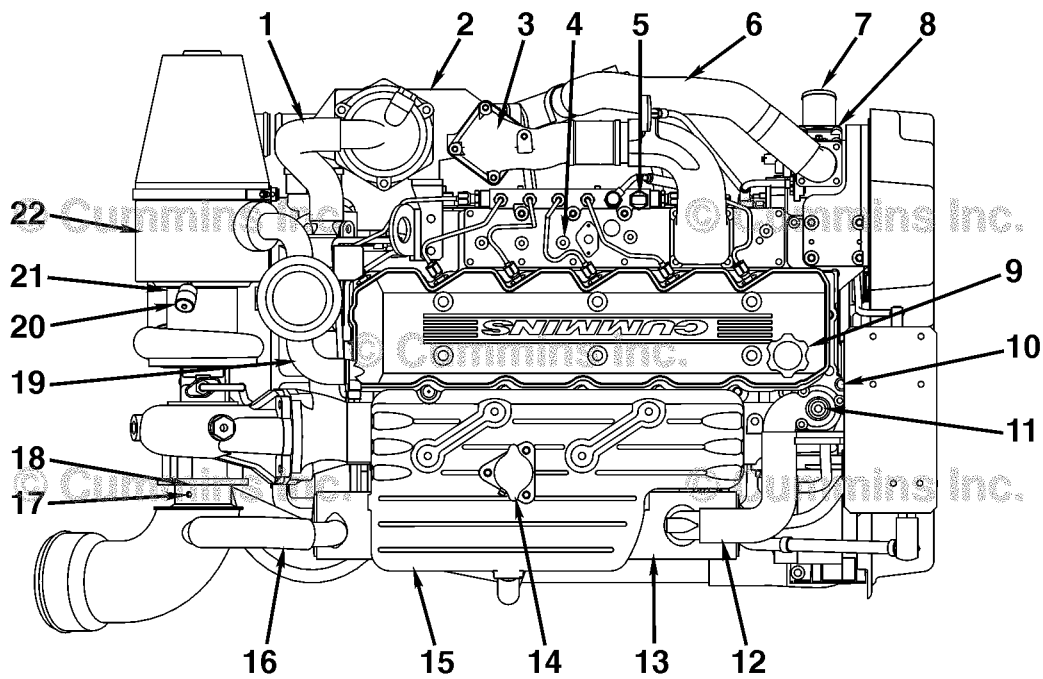

QSB CM850, 5.9 Liter Marine Engine (Top View)

00d00157

- 1 Aftercooler sea water outlet
- 2 Aftercooler housing
- 3 Intake air connection from aftercooler to intake manifold
- 4 Intake manifold pressure and temperature port
- 5 Fuel rail pressure sensor
- 6 Sea water supply to fuel cooler
- 7 Sea water pump inlet
- 8 Sea water pump
- 9 Engine oil fill
- 10 Coolant temperature sensor
- 11 Coolant pressure side vent petcock
- 12 Heat exchanger engine coolant inlet
- 13 Heat exchanger
- 14 Coolant fill neck
- 15 Expansion tank
- 16 Sea water outlet from heat exchanger
- 17 Exhaust temperature and back pressure port
- 18 Exhaust outlet connection
- 19 Closed crankcase breather blow-by connection
- 20 Air inlet restriction indicator
- 21 Air cleaner connection
- 22 Closed crankcase breather/air cleaner assembly

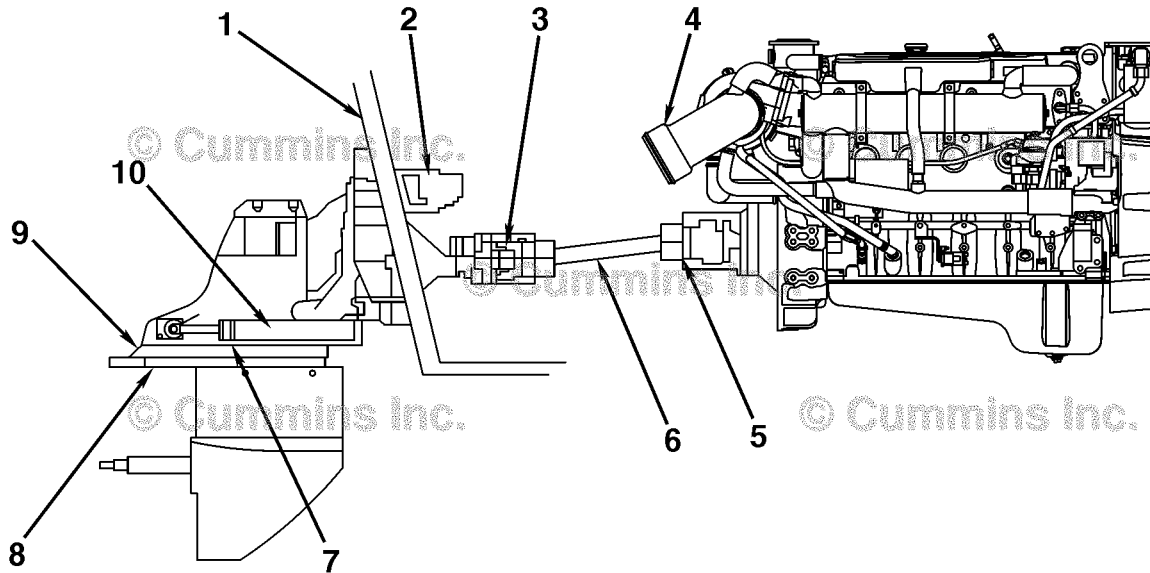

00d00257

QSB CM850, 5.9 Liter Marine Engine Sterndrive™ (Starboard View)

- 1 Boat transom
- 2 Steering cylinder
- 3 Bearing support assembly
- 4 Exhaust elbow
- 5 Tailstock assembly
- 6 Driveshaft
- 7 Trim cylinder zinc anode
- 8 Ventilation plate zinc anode
- 9 Sterndrive™
- 10 Trim cylinder.

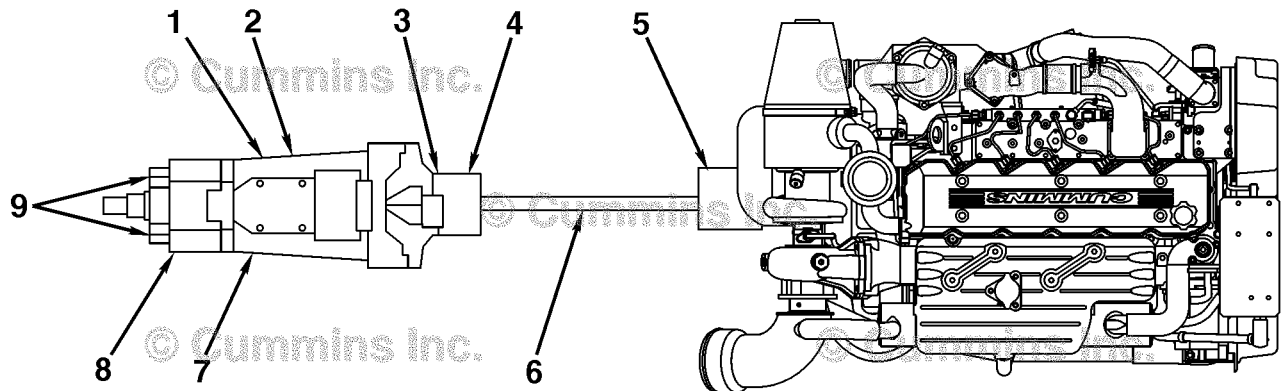

00d00258

QSB CM850, 5.9 Liter Marine Engine Sterndrive™ (Top View)

- 1 Sterndrive™
- 2 Trim cylinder
- 3 Steering cylinder (not shown)
- 4 Bearing support assembly
- 5 Tailstock assembly
- 6 Driveshaft
- 7 Trim cylinder
- 8 Ventilation plate zinc anode (bottom of ventilation plate)
- 9 Trim cylinder zinc anode.

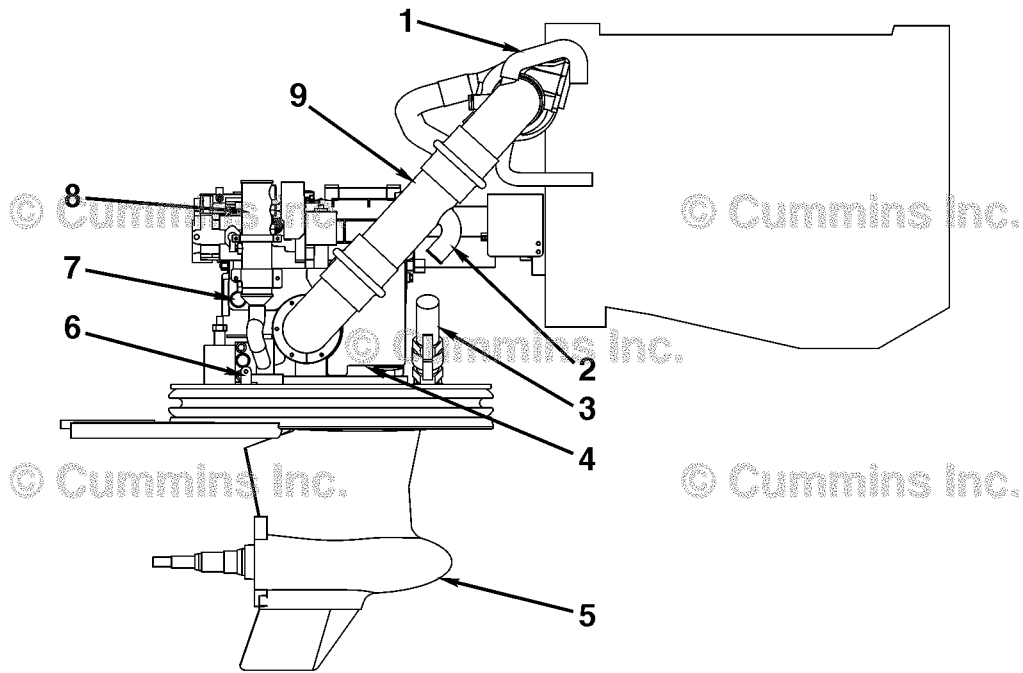

Zeus™ 3500 Non Drop-Box (Starboard View)

00800058

- 1 Sea water outlet from engine
- 2 Sea water outlet bypass to muffler
- 3 Sea water inlet and seacock
- 4 Steering and transmission fluid drain
- 5 Gear oil drain plug
- 6 Sea water outlet valve
- 7 Transmission drain
- 8 Steering and transmission oil cooler
- 9 Exhaust outlet connection.

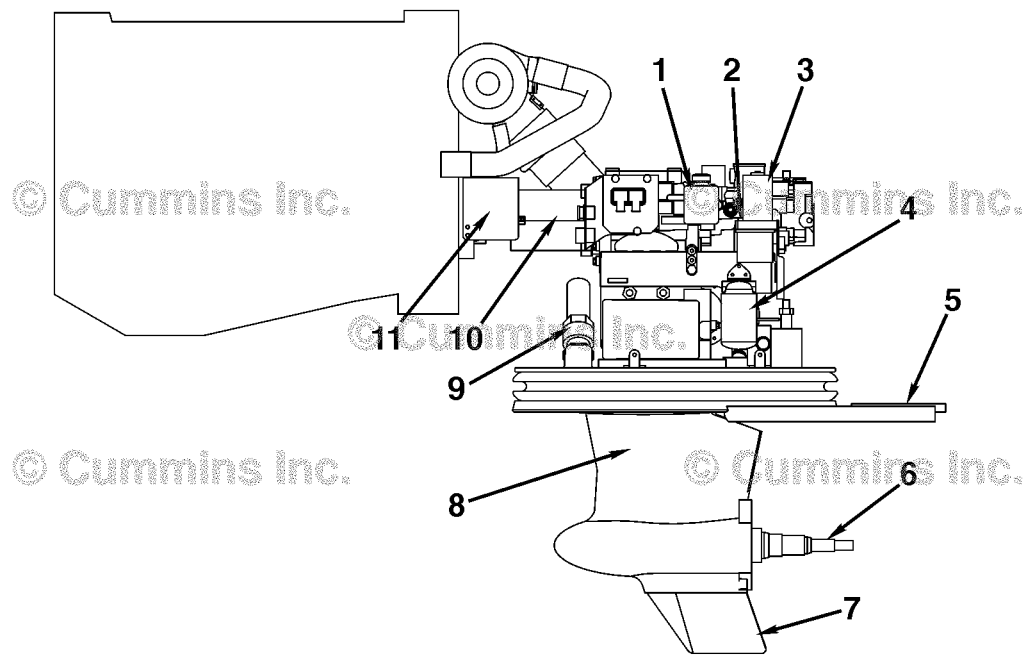

Zeus™ 3500 Non Drop-Box (Port View)

00800059

- 1 Gear housing oil reservoir and fill
- 2 Backup steering pump fill and dipstick
- 3 Steering back up pump
- 4 Steering and trim tab fluid filter
- 5 Trim tab and zinc anode
- 6 Propeller shaft
- 7 Drive skag
- 8 Gear housing
- 9 Sea water inlet and seacock
- 10 Drive shaft (under shield)
- 11 Drive shaft shield.

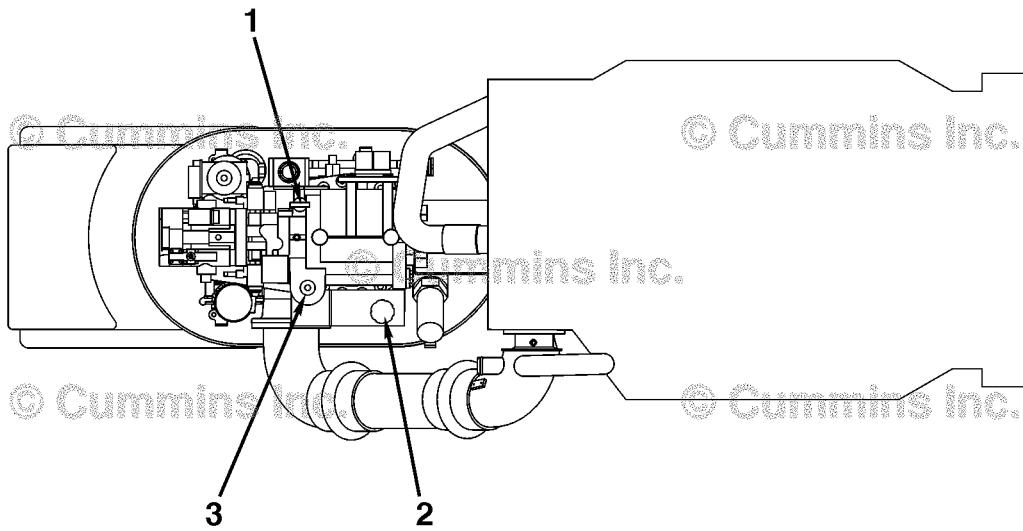

Zeus™ 3500 (Top View)

00800060

- 1 Transmission dipstick
- 2 Steering and transmission fluid reservoir fill
- 3 Transmission filter.

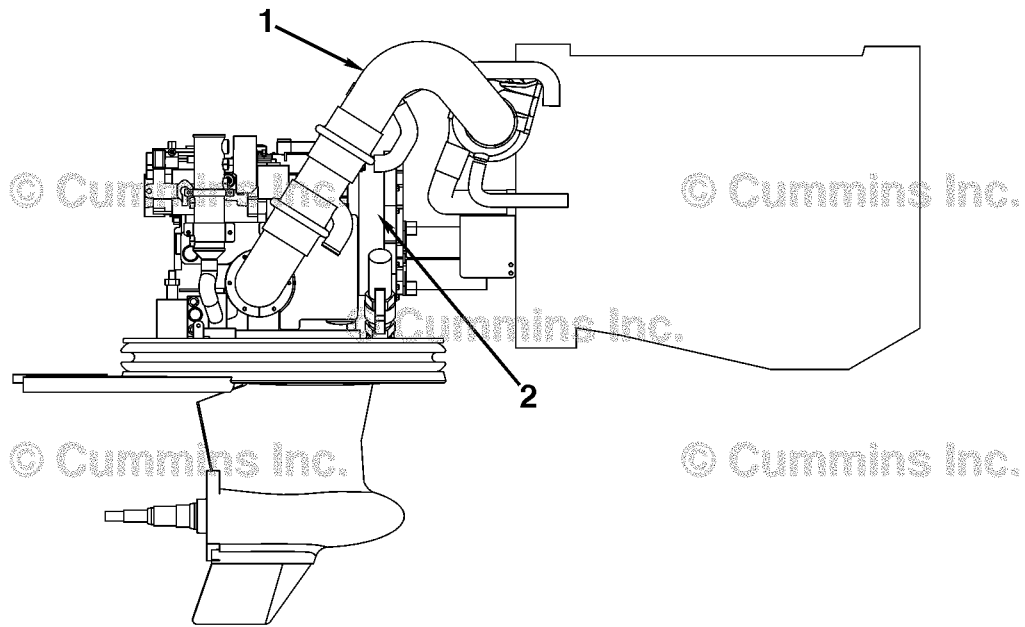

Zeus™ 3500 Drop Box (Starboard View)

- 1 Exhaust riser
- 2 Transmission drop box.

00800061

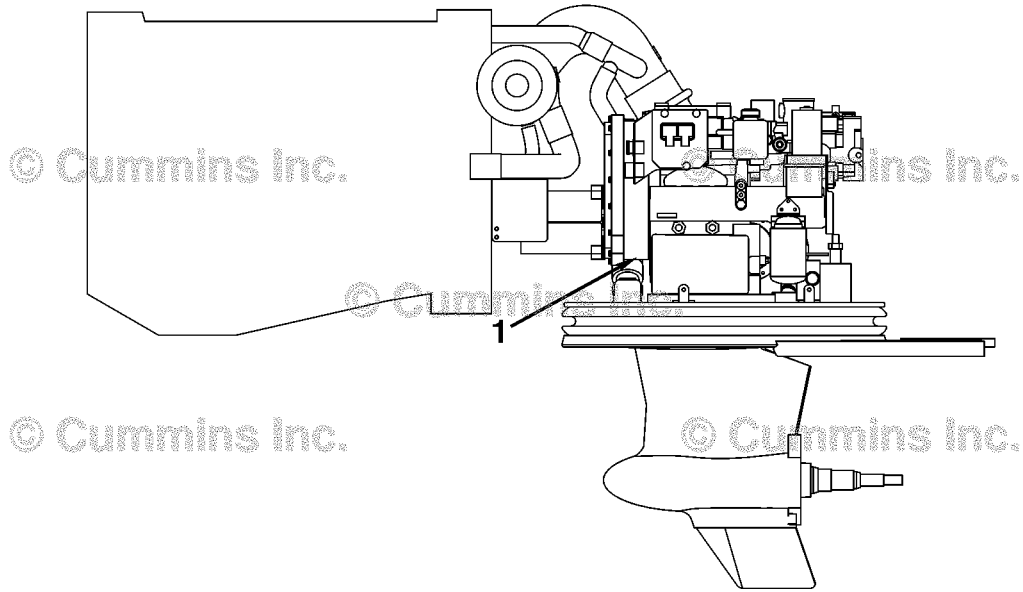

00800062

Zeus™ 3500 Drop Box (Port View)

- 1 Drop box drain plug

Cummins® Service Engine Model Product Identification

General Information

The Cummins® Service Engine Model Nomenclature procedure describes how engines are identified within Cummins service organization. This method was introduced for models after and including manufacture year 2007.

Electronic engines are identified by the first two letters, either an "IS" for On-Highway automotive or "QS" for Off-Highway industrial market applications.

The third letter is the engine platform designation followed by the engine liter size.

If the engine operates on a fuel type other than diesel, the type will be identified after the liter size.

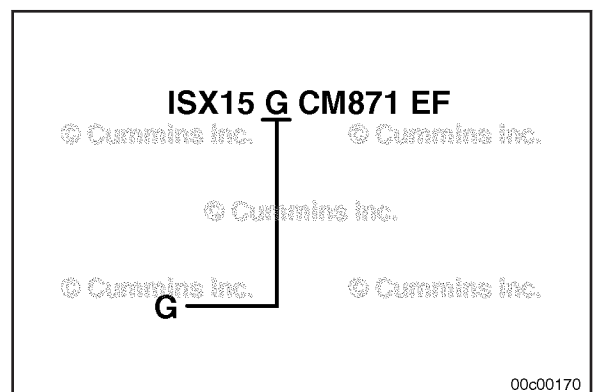
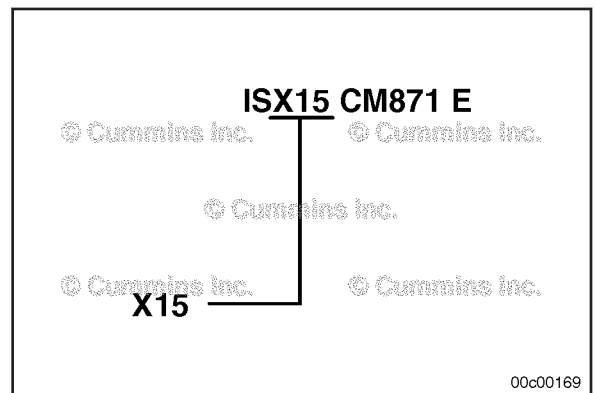
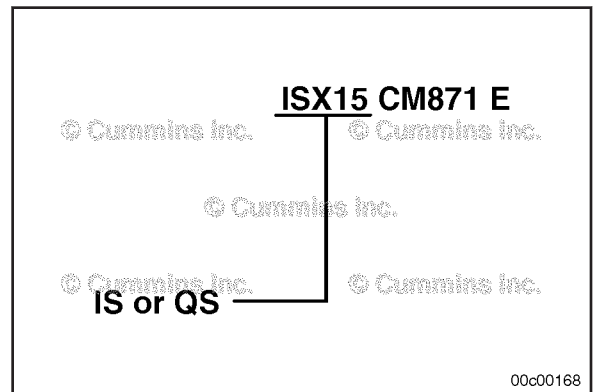

The control system is identified with the letters "CM" followed by the control system model number.

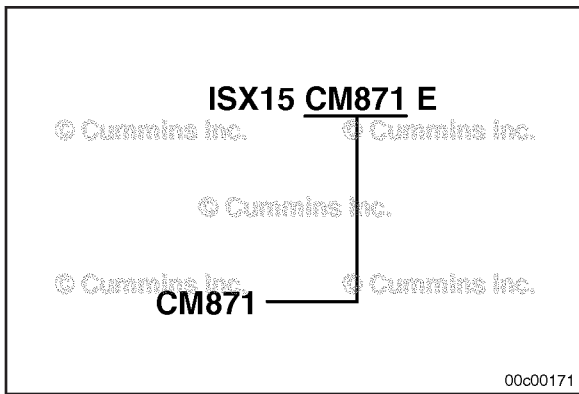

The technology identifier after the control system designates the prevailing technology used with the engine. (See table in this procedure for letter designations.)

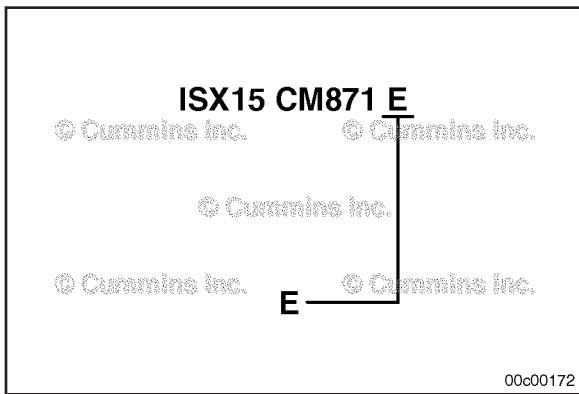

Example:

- 1 On-Highway automotive "X" 15 liter engine
- 2 Control system number 871
- 3 Technology supported; Electric EGR and Diesel Particulate Filter

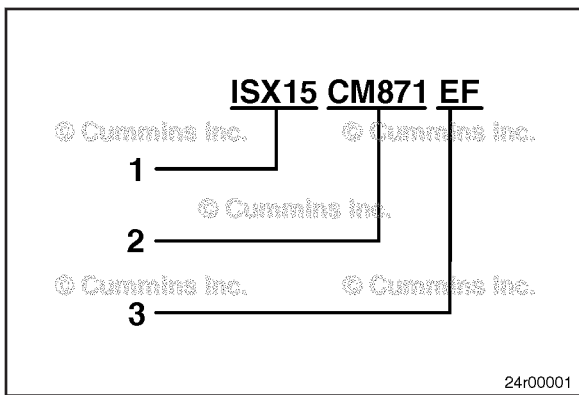

Technology	Name	Suffix
Exhaust Gas Recirculation	Not used	None
	Pneumatic	P
	Electric	E
Diesel Particulate Filter (DPF)	Not used	None
	Full Flow DPF	F
	Partial Flow DPF	F2
Diesel Oxidation Catalyst	Not used	None
	DOC	C
3-Way Oxidation Catalytic Converter	Not used	None
	3-Way Catalyst	J
Selective Catalytic Reduction System	Not used	None
	Air Driven	S
	Airless	A
Nox Sensor	Not used	None
	Nox Sensor	N
Modular Common Rail System	Used only on QSK19, 38, 50 , 60 HHP Engines	MCRS
Integrated Dosing Control Unit	Not Used	None
	Integrated	I

Section F - Familiarization

Section Contents

	Page
Air Intake System - Overview	F-38
General Information.....	F-38
Complete Engine - Overview	F-1
General Information.....	F-1
Compressed Air System - Overview	F-51
General Information.....	F-51
Cooling System - Overview	F-31
General Information.....	F-31
Cylinder Block - Overview	F-1
General Information.....	F-1
Electrical Equipment - Overview	F-53
General Information.....	F-53
Engine Testing - Overview	F-54
General Information.....	F-54
Flow Diagram, Air Intake System	F-45
General Information.....	F-45
Flow Diagram, Compressed Air System	F-52
Flow Diagram.....	F-52
Flow Diagram, Cooling System	F-33
Flow Diagram.....	F-33
Flow Diagram, Exhaust System	F-48
General Information.....	F-48
Flow Diagram, Fuel System	F-11
General Information.....	F-11
Flow Diagram, Lubricating Oil System	F-25
General Information.....	F-25
Fuel System - Overview	F-6
General Information.....	F-6
Injectors and Fuel Lines - Overview	F-14
General Information.....	F-14
Lubricating Oil System - Overview	F-16
General Information.....	F-16

This Page Left Intentionally Blank

Complete Engine - Overview (000-999)



General Information

The procedures required to replace an engine will vary with different engine models, type of equipment, optional equipment, and shop facilities. Use the following procedures as a guide.

NOTE: All replacement steps will **not** apply to all types of equipment. Complete **only** the steps that apply to the equipment involved. Use the equipment manufacturer's recommendations and precautions for removal of chassis parts to gain access to the engine.

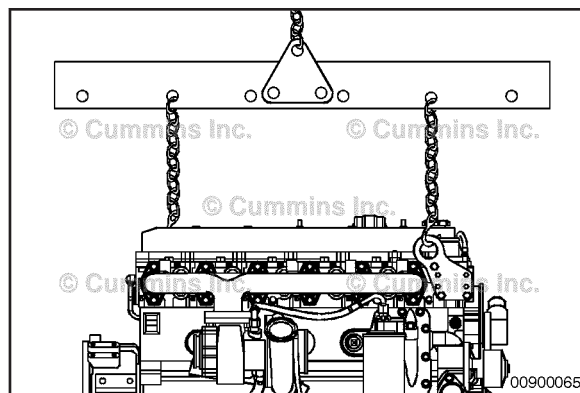

Cylinder Block - Overview (001-999)

General Information

Connecting Rods

This familiarization section helps to identify and orient the various styles of ISB connecting rods for installation. These details are important because some connecting rods are **not** marked with a part number and identification can be difficult. This section will also discuss the acceptability of mixing connecting rods with different part numbers to make a repair.

B Series engines use various connecting rods installed in different orientations, depending on where and when the engine was built. Generally, connecting rods should be installed in the same orientation as they were prior to removal. In special circumstances, this familiarization section may be referenced as a guideline.

The following information illustrates connecting rod styles and orientations for the Cummins® B Series 3.9 Liter (4 cylinder) and 5.9 Liter (6 cylinder) engines.

Each illustration shows the connecting rod and camshaft (1) as viewed from the front of the engine. The connecting rod capscrew holes help define the orientation of the connecting rod to the camshaft. One side of the rod has a through hole (2) and the other has a blind hole (3). The through hole is drilled through the rod. The blind hole is drilled into the rod and does not have an exit hole.

There are two possible orientations for the connecting rod:

- Through hole (2) toward the camshaft
- Blind hole (3) toward the camshaft.

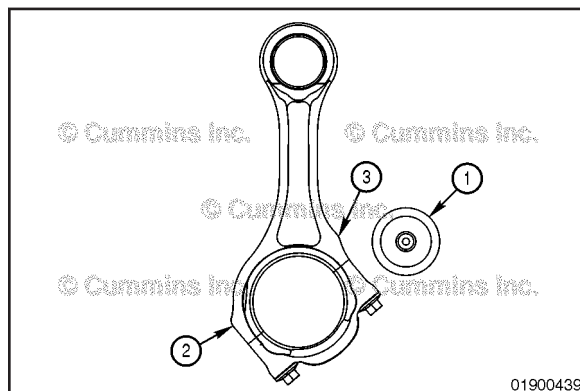

Connecting Rod Part Number:	3942581 (3942581 shown)
Cylinder Block:	ISB CM550, ISB CM850
Connecting Rod Joint:	Machined
Cylinder Bore:	102 mm [4.015 in]
Cylinder Stroke:	120 mm [4.724 in]
Orientation:	Blind hole toward camshaft

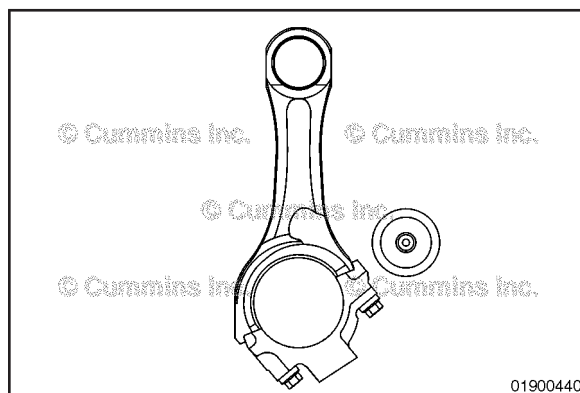

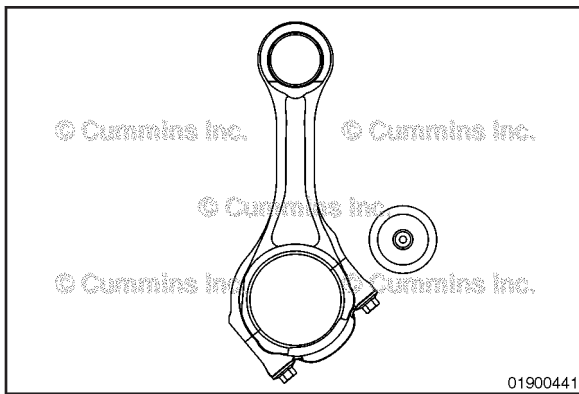

Connecting Rod Part Number:	3954658, 3971212, 4891176, 4935880, 4943979, 4989163, 5257364 (3954658 shown)
Cylinder Block:	ISB CM550
Connecting Rod Joint:	Fractured
Cylinder Bore:	102 mm [4.015 in]
Cylinder Stroke:	120 mm [4.724 in]
Orientation:	Blind hole toward camshaft

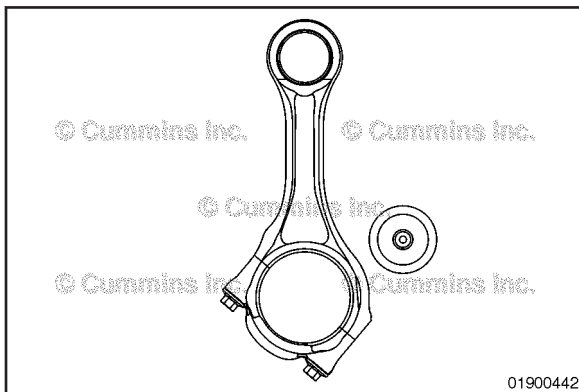

Connecting Rod Part Number:	3954658, 3971212, 4891176, 4935880, 4943979, 4989163, 5257364 (3954658 shown)
Cylinder Block:	ISB CM850
Connecting Rod Joint:	Fractured
Cylinder Bore:	102 mm [4.015 in]
Cylinder Stroke:	120 mm [4.724 in]
Orientation:	Through hole toward camshaft

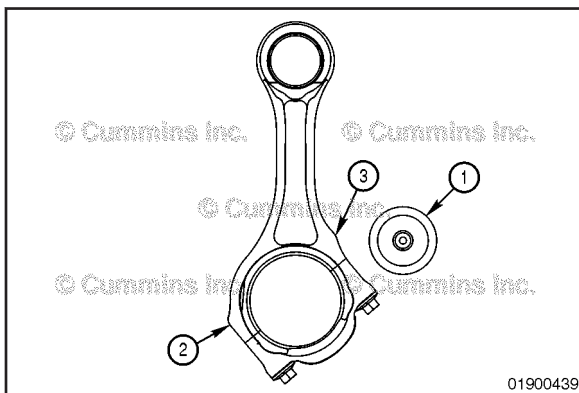

The following information illustrates connecting rod styles and orientations for the Cummins® B Series 4.5 Liter (4 cylinder) and 6.7 Liter (6 cylinder) engines.

Each illustration shows the connecting rod and camshaft (1) as viewed from the front of the engine. The connecting rod capscrew holes help define the orientation of the connecting rod to the camshaft. One side of the rod has a through hole (2) and the other has a blind hole (3). The through hole is drilled through the rod. The blind hole is drilled into the rod and does not have an exit hole.

There are two possible orientations for the connecting rod:

- Through hole (2) toward the camshaft
- Blind hole (3) toward the camshaft.

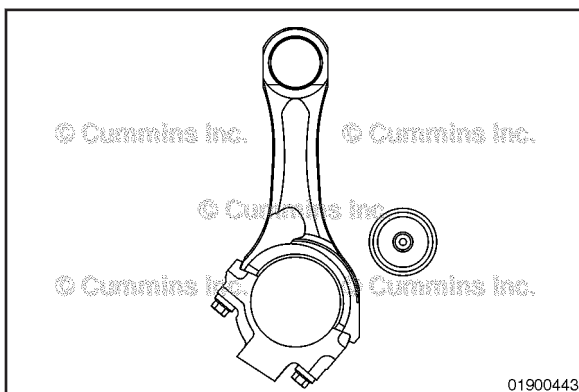

Connecting Rod Part Number:	3942581 (3942581 shown)
Cylinder Block:	ISB 4.5, ISB 6.7
Connecting Rod Joint:	Machined
Cylinder Bore:	107 mm [4.212 in]
Cylinder Stroke:	124 mm [4.881 in]
Orientation:	Through hole toward camshaft

Connecting Rod Part Number:	3954658, 3971212, 4891176, 4935880, 4943979, 4989163, 5257364 (4943979 shown)
Cylinder Block:	ISB 4.5, ISB 6.7
Connecting Rod Joint:	Fractured
Cylinder Bore:	107 mm [4.212 in]
Cylinder Stroke:	124 mm [4.881 in]
Orientation:	Blind hole toward camshaft

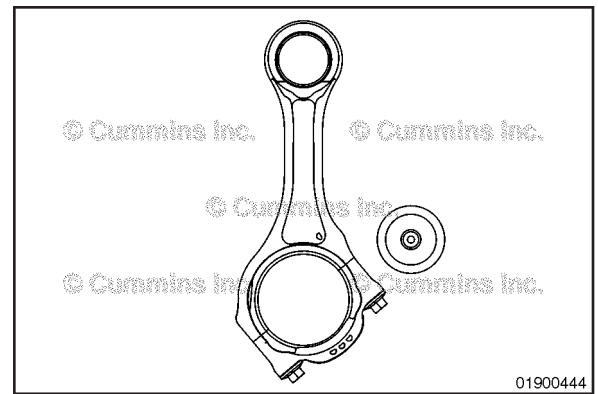

Cylinder Block - Overview (001-999)

General Information

Use the following illustrations to identify 3.9 Liter, 4.5 Liter, 5.9 Liter, and 6.7 Liter (6 cylinder) connecting rods.

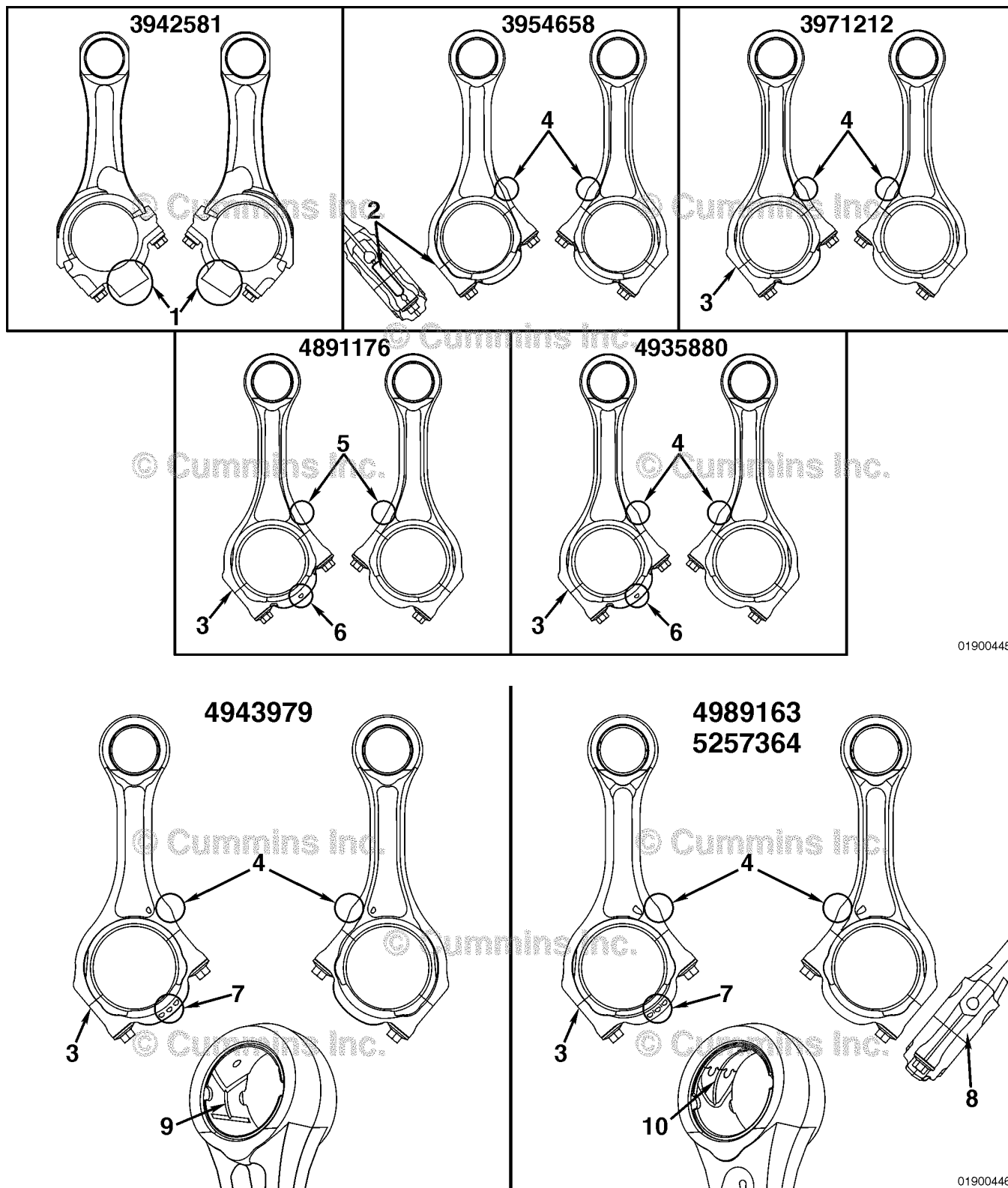

01900445

01900446

Note: Lead-free bushings (10) Part Numbers 4983518 and 5257363 are not serviceable.

Connecting Rod Characteristics

1 Balancer

2 Machined surface

To buy Cummins Parts and Service Manuals, Training Guides, or Tools go to our website at <https://store.cummins.com>

- 3 Non-machined surface
- 4 Bump or bulge
- 5 Smooth
- 6 Single dimple
- 7 Three dimple
- 8 "TA LF" or "7364"
- 9 Oil grooves in leaded bushing Part Number 4891178
- 10 Oil grooves in lead-free bushings Part Numbers 4983518/5257363. (These bushings are **not** serviceable)

Due to weight differences that will result in engine vibration, special consideration **must** be given to mixing certain connecting rods in a single engine.

- In engines built before January 1, 2010, with connecting rod Part Numbers 4935880, 4943979, 4989163, and 5257364: these rods may **only** be mixed with each other.
- In engines built after January 1, 2010, with connecting rod Part Numbers 4989163, and 5257364: these rods may **only** be mixed with each other.
- Connecting rod Part Number 3954658 and 3971212 may **only** be mixed with each other.
- Connecting rod Part Number 4891176 **must never** be mixed with any other connecting rod.
- Connecting rod Part Number 3942581 **must never** be mixed with any other connecting rod.

Fuel System - Overview (005-999)

General Information

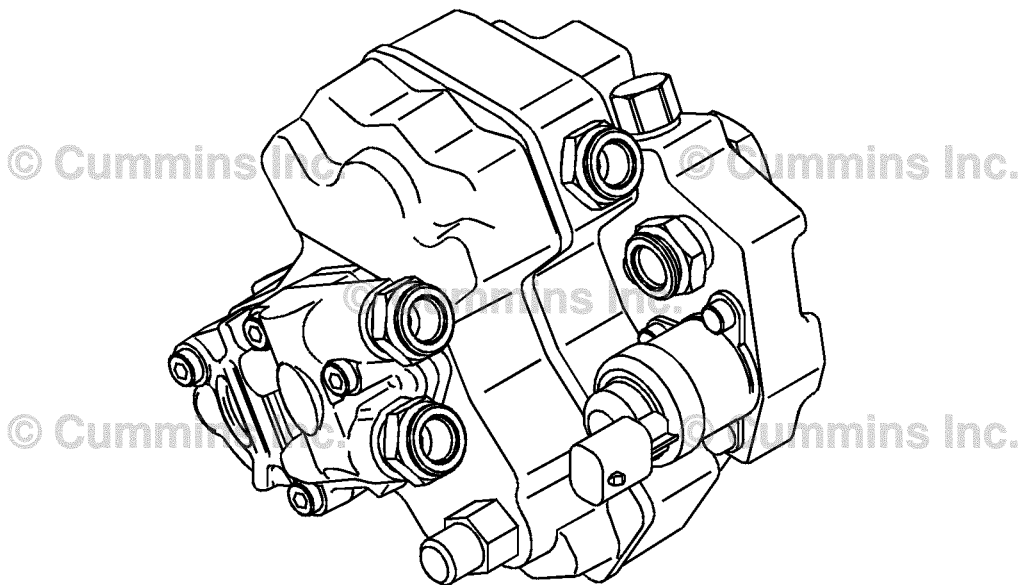

05d00194

The fuel system is a high-pressure common rail electronically controlled fuel system. The high-pressure common rail system consists of four main components: Fuel pump gear pump, high-pressure pump, fuel rail, and injectors. The high-pressure pump supplies high-pressure fuel to the fuel rail independent of engine speed. The high-pressure fuel is then accumulated in the fuel rail. High-pressure fuel is constantly supplied to the injectors by the fuel rail. The electronic control module (ECM) controls the fueling and timing of the engine by actuating the injectors.

On the low pressure side of the fuel system, some engines contain a fuel cooled ECM cooling plate and/or an electric lift pump. Automotive and industrial applications with an ECM cooling plate are laid out so that fuel enters the ECM cooling plate, if equipped, from the original equipment manufacturers (OEM) fuel supply line connection. After exiting the ECM cooling plate, fuel may flow into an electric fuel transfer pump, if equipped. Marine applications are laid out opposite to this flow, such that fuel flows through the electric fuel transfer pump prior to the ECM cooling plate.

For engines with an electric lift pump, the fuel/water separating fuel filter is located between the outlet of the electric lift pump (outlet of fuel cooled ECM cooling plate for marine applications), and the inlet to the fuel pump gear pump. The outlet pressure of the electric lift pump (approximately 11 psi) is used to filter fuel passing through the fuel/water separator. The fuel/water separating filter may be located on the engine, or remotely off of the engine. After entering the fuel pump gear pump, fuel flows through internal passages to the high-pressure fuel pump.

For engines without an electric lift pump, a suction side fuel/water separating filter is required. This filter is located off of the engine and contains a hand priming pump. Fuel enters the engine at the ECM cooling plate, if equipped, and then flows to the fuel pump gear pump. Using fuel pump gear pump pressure (approximately 44-189 psi), fuel is filtered using an on-engine or remotely mounted fuel filter prior to entering the high-pressure fuel pump.

The fuel that enters the high-pressure fuel pump is pressurized between 250 and 1800 bar [3626 to 26107 psi] by three radial pumping chambers. An M-Prop valve, or electronic fuel control (EFC) valve, at the inlet to the three radial

pumping chambers regulates the volume of fuel that is allowed to enter the pumping chambers. By regulating the volume of fuel that is pressurized, the M-Prop valve uses signals from the ECM to maintain the pressure in the fuel rail at a desired level. Fuel that is **not** allowed to enter the three radial pumping chambers is directed through the Cascade Overflow Valve. The Cascade Overflow Valve directs a certain amount of pressure to the lube channels of the high pressure pump and then returns the fuel to the fuel tank.

The fuel rail acts as a fuel manifold accumulating and distributing fuel to each of the injector supply lines. Within the fuel rail, there is a fuel rail pressure sensor that monitors the pressure provided to the fuel rail from the high-pressure fuel pump. Pressure measured by the fuel rail pressure sensor is used by the ECM to adjust the fuel output of the high-pressure pump. The fuel rail also contains a fuel rail pressure relief valve. The fuel rail pressure relief valve is a safety valve used to bleed off excess pressure if the rail pressure exceeds a preset threshold. Fuel bled off by the fuel rail pressure relief valve is returned to the fuel tank through a fuel drain line connected to the fuel rail.

Some engines are equipped with supply and return shut-off valves. Be sure to return these valves to the open position prior to cranking or starting the engine. Failure to do so will result in a high fuel drain restriction capable of: (1) Damage to the injector pump (2) Fuel entering the crankcase lubricating oil (3) Damage to the fuel cooler, for marine applications **only** (4) Fuel being pumped into seawater, marine applications only (5) and seawater entering the fuel tanks, marine applications **only**

Installation Publications

Contact the nearest Cummins Authorized Repair Location for engine fuel system specifications and requirements provided on the Engine Data Sheet for your specific engine and application.

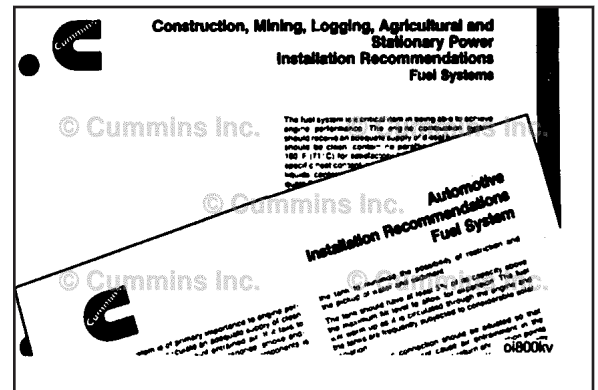

⚠️ WARNING ⚠️

The fuel pump, high-pressure fuel lines, and fuel rail contain very high-pressure fuel. Do not loosen any fittings while the engine is running. Personal injury and property damage can result. Wait at least 10 minutes after shutting down the engine before loosening any fittings in the high-pressure fuel system to allow pressure to decrease to a lower level.

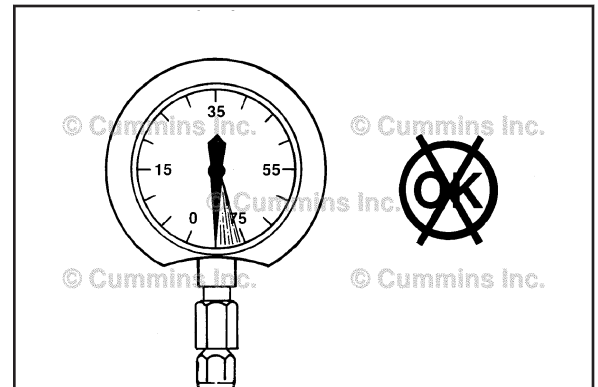

⚠️ CAUTION ⚠️

Never exceed the maximum capacity of the gauge or flowmeter. Exceeding the maximum capacity will cause the gauge to read incorrectly. If the maximum is exceeded, check the gauge against a reference gauge.

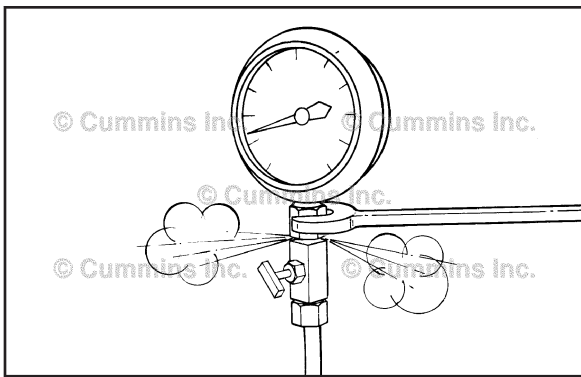

Proper Use of Fuel System Gauges

⚠ CAUTION ⚠

Do not loosen the vacuum gauge connections when the engine is operating. Doing so can introduce air into the fuel system, causing the engine to run rough or stall.

NOTE: To be sure the pressure gauge reading is correct, **always** remove the air from the pressure gauge line before taking a reading.

Loosen the connection at the gauge to remove the air.

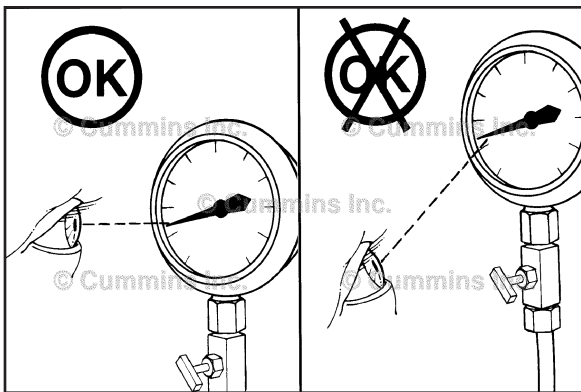

Read the gauge in direct alignment with the gauge hand.

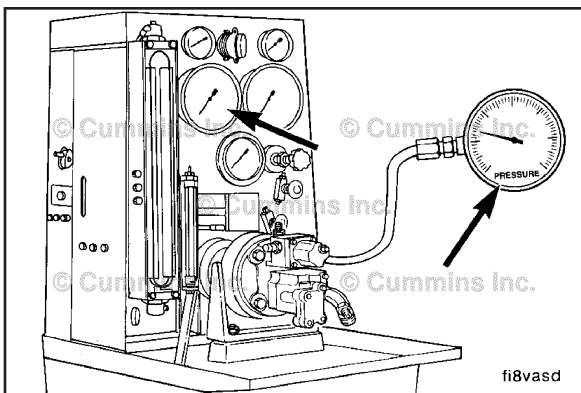

Portable fuel pressure gauges **must** be checked regularly against a reference gauge or against the gauge on the fuel pump test stand. Adjust the valve on the gauge until the gauge needle stops vibrating.

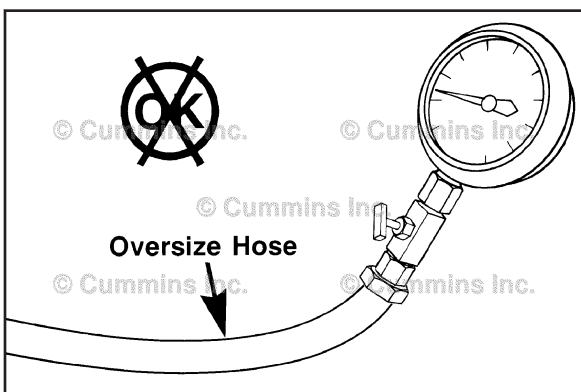

NOTE: **Always** use the same size and material of line or hoses that were originally supplied with the gauge.

The distance from the gauge to the connection point **must** be as short as possible.

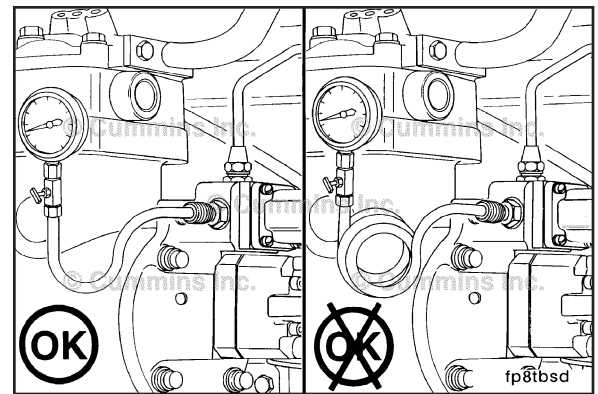

The QSB5.9-425 is equipped with the new high-pressure common rail fuel system. The system allows multiple injection events per cylinder firing that are **not** coupled to a mechanical system such as an injection pump rotor or injection camshaft. The high-pressure common rail system is simple, easy to service, and has many advantages over other fuel systems with regards to troubleshooting and diagnostics.

- Troubleshooting to the exact failed component is simplified.
- Functions normally performed by the fuel system have been split into several components on the high-pressure common rail system, simplifying diagnostics:
- Injection control valve = 6 injectors
- Accumulator = fuel rail
- Distribution module = 6 injector solenoids.
- The injection event is **not** coupled with a mechanical system such as an injection pump rotor or injection camshaft, ruling out “mis-calibration questions.

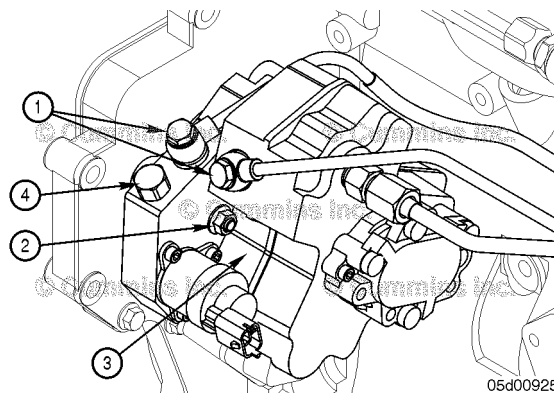

Overflow Valve

Item Number	Description
1	Bolts, banjo
2	Nuts, pump mounting (3)
3	Pump, fuel injection
4	Valve, cascade overflow

The QSB5.9-425 utilizes an electric lift pump, which draws fuel from the tank and pressurizes the inlet to a gear pump on the back of the high-pressure injection pump. This lift pump runs continuously during engine operation and will run for 60 seconds at the key on position prior to cranking. The connection between the gear pump and the high-pressure common rail **must not** be removed or cracked to bleed air from the fuel. Fuel is delivered from the secondary fuel filter to the high-pressure pump where it is pressurized to 1600 bar and sent to the rail. Fuel travels from the rail through a high pressure line through the high-pressure connector and finally through the injector.

Tools required to troubleshoot the common rail system include:

- M10 Compuchek® fittings
- Orificed diagnostic fuel line, 0.043 mm [.002 in]

- Vacuum gauge, 0 to 102 kPa [0 to 30 in hg]
- Diagnostic T adapter
- Gauge, 2068 kPa [0-300 psi]
- M12 drain flow adapter
- Fuel rail blocker (for injector isolation)
- INSITE™ electronic service tool (to raise pressure).

Component or System	Specification
Maximum restriction inlet fitting (Original Equipment Manufacturer (OEM) connection point)	8 kPa [2.5 in hg] clean filter or 14 kPa [4 in hg] dirty filter.
Maximum restriction gear pump inlet	34 kPa [10 in hg] dirty filter
Minimum lift pump pressure while cranking	34 kPa [5 psi]
Maximum pressure filter drop	Less than 17 kPa [Less than 5 in hg]
Minimum gear pump pressure while cranking	48 kPa [7 psi]
Normal operating pressure in accumulator "rail"	29,992 to 159,958 kPa [4,350 to 23,200 psi]
Maximum main drain valve leakage	100 cc [.11 quart] per minute @ 1500 rpm
	300 cc [.32 quart] per minute @ cranking
Maximum injector leakage	300 cc [.32 quart] per minute @ 1500 rpm
	300 cc [.32 quart] per minute @ cranking
Maximum high pressure pump leakage	300 cc [.32 quart] per 30 seconds @ 1500 rpm
	300 cc [.32 quart] per 30 seconds @ cranking

Flow Diagram, Fuel System (200-001)

General Information

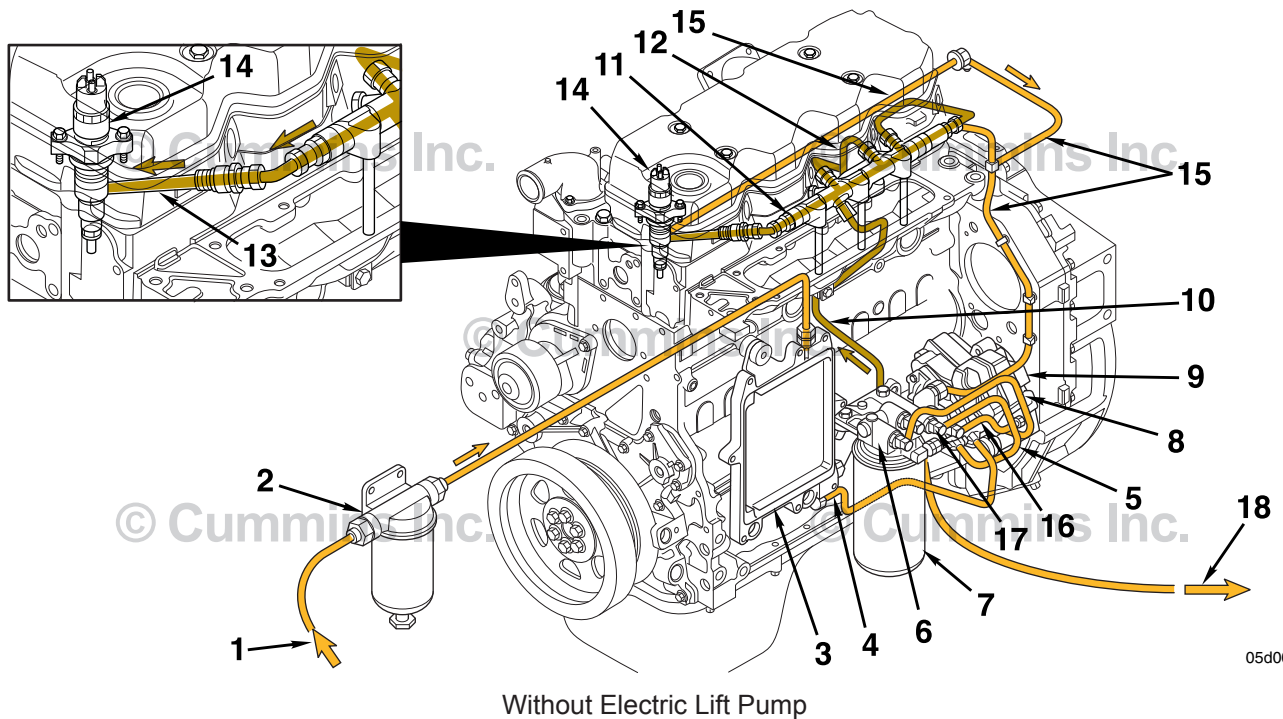

05d00888

- 1 From fuel supply tank
- 2 Water/fuel separator (**not** mounted on engine)
- 3 ECM cooling plate*
- 4 To fuel gear pump
- 5 To fuel filter
- 6 Fuel filter head
- 7 Fuel filter
- 8 To high-pressure pump
- 9 High-pressure pump
- 10 To fuel rail
- 11 Fuel rail
- 12 To injectors
- 13 High-pressure connector
- 14 Injector
- 15 Fuel return from injectors and fuel rail to fuel filter head
- 16 Fuel return from high-pressure pump to fuel filter head
- 17 Fuel return manifold
- 18 To fuel supply tank.

NOTE: * Engines are either equipped with an air cooled or fuel cooled ECM. If an air cooled ECM is used, the fuel enters the engine from the OEM connection at the gear pump inlet.

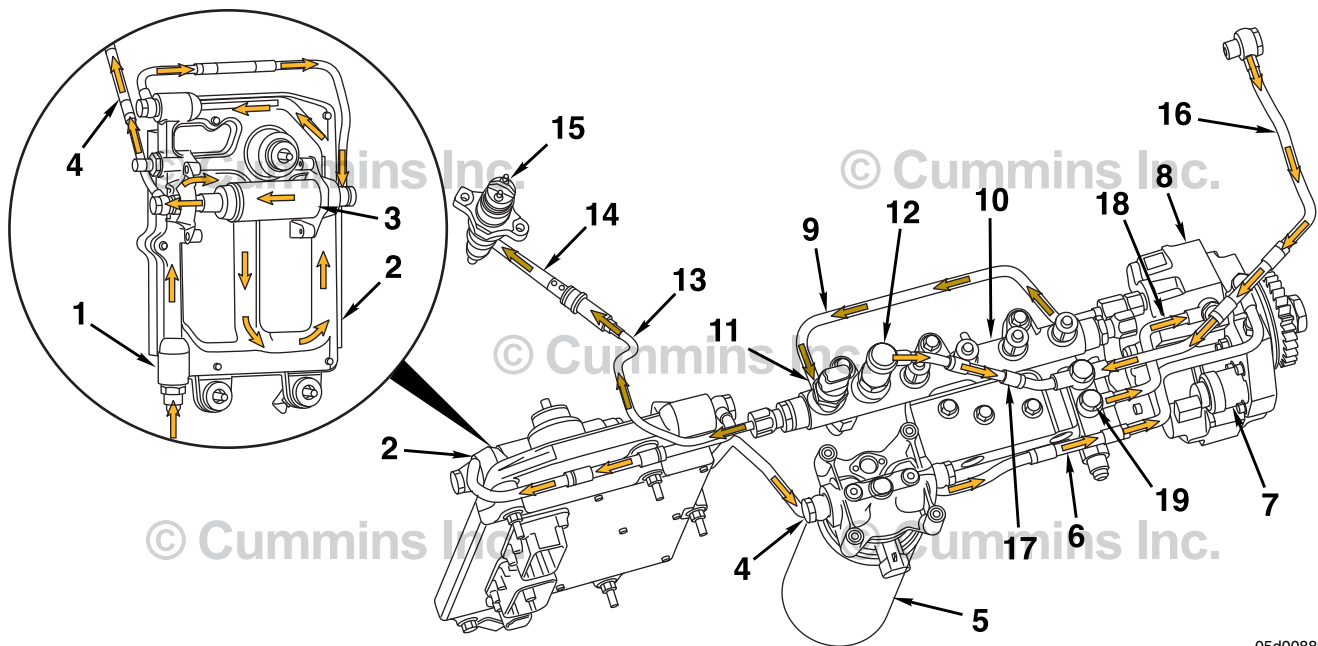

05d00889

With Electric Lift Pump

- 1 Fuel inlet - ECM cooling plate
- 2 ECM cooling plate
- 3 Lift pump
- 4 Fuel line (from lift pump to fuel filter)
- 5 Fuel filter
- 6 Fuel pump inlet to gear pump
- 7 EFC actuator
- 8 Fuel pump
- 9 High-pressure fuel line (fuel pump to rail)
- 10 Fuel rail
- 11 Fuel rail pressure sensor
- 12 Fuel pressure relief valve
- 13 High-pressure fuel line (fuel rail to fuel injector)
- 14 High-pressure connector to fuel injector
- 15 Fuel injector
- 16 Injector return line
- 17 Pressure relief return line
- 18 Fuel pump return line
- 19 Fuel return manifold.

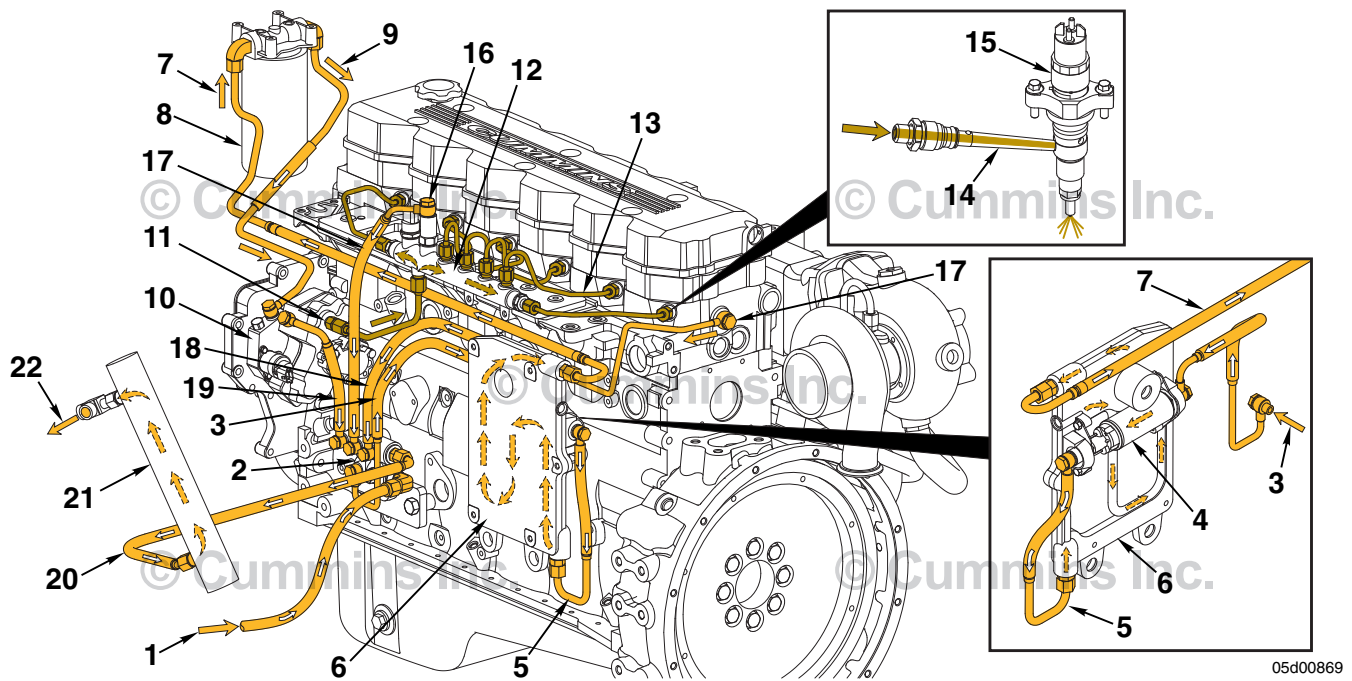

05d00869

- 1 Fuel inlet from fuel tank
- 2 Fuel manifold
- 3 Fuel inlet to fuel lift pump
- 4 Fuel lift pump
- 5 Lift pump to cooling plate
- 6 ECM cooling plate
- 7 ECM cooling plate outlet to fuel filter inlet
- 8 Fuel filter
- 9 Fuel filter outlet to fuel pump
- 10 High pressure fuel pump
- 11 High pressure fuel supply to fuel rail
- 12 Common fuel rail
- 13 High pressure fuel line to injector
- 14 High pressure connector
- 15 Injector
- 16 Fuel pressure relief valve
- 17 Pressure relief return line
- 18 Injector return line
- 19 Fuel pump to fuel manifold return
- 20 Fuel manifold to fuel cooler
- 21 Fuel cooler
- 22 Fuel return to tank.

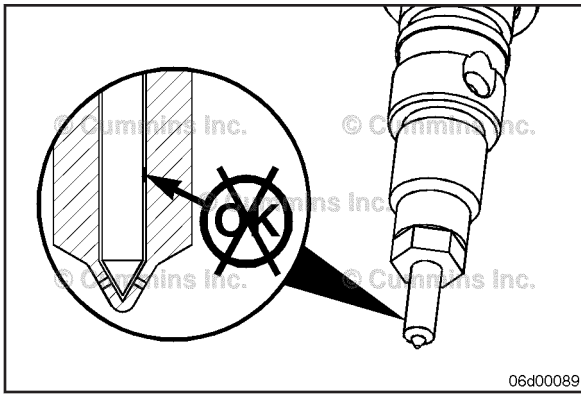

Injectors and Fuel Lines - Overview (006-999)

General Information

⚠ WARNING ⚠

Fuel is flammable. Keep all cigarettes, flames, pilot lights, arcing equipment, and switches out of the work area and areas sharing ventilation to reduce the possibility of severe personal injury or death when working on the fuel system.

High-pressure common rail fuel systems use solenoid-actuated injectors. High-pressure fuel flows into the side of the injector. When the solenoid is activated, an internal needle lifts and fuel is injected. The clearances in the nozzle bore are extremely small and any dirt or contaminants will cause the injector to stick. This is why it is important to clean around all fuel connections before servicing the fuel system. Also, cap or cover any open fuel connections before a fuel system repair is performed.

⚠ CAUTION ⚠

To reduce the possibility of engine damage, always use the proper torque on the high-pressure line nuts.

High-pressure fuel is supplied to the injector from the fuel rail by an injector supply line and a fuel connector. The fuel connector pushes against the injector body when the fuel connector nut is tightened. The injector supply line is then connected to the fuel connector.

The torque on this fuel connector and the injector supply lines is critical. If the nut or line is undertightened, the surfaces will **not** seal and a high-pressure fuel leak will result. If the nut is overtightened, the connector and injector will deform and cause a high-pressure fuel leak. This leak will be inside the head and will **not** be visible. The result will be a fault code, low power, or no-start.

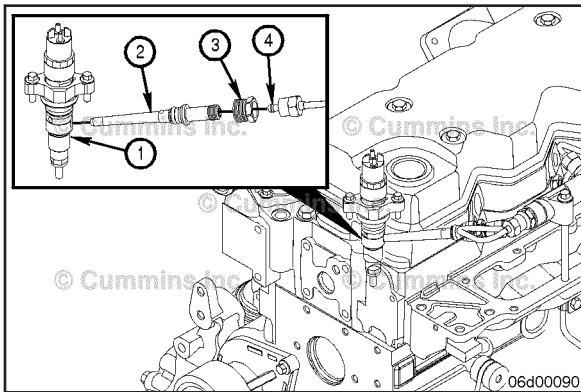

The fuel connector contains an edge filter that breaks up small contaminants that enter the fuel system. The edge filter uses the pulsating high pressure to break up any particles so that they are small enough to pass through the injector.

NOTE: The edge filters are **not** a substitute for cleaning and covering all fuel system connections during repair. Edge filters are **not** a substitute for maintaining the recommended engine mounted fuel filter.

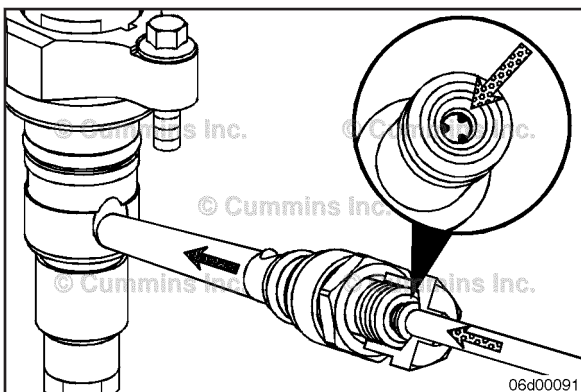

All injectors feed into a common return circuit contained within the cylinder head. Any excess fuel is returned to the tank via this drilling in the cylinder head and return line attached to the rear of the cylinder head. A back-pressure valve is located on the back of the cylinder head where the drain line attaches. The fuel drain lines may have either a quick-disconnect fitting or a banjo fitting at ends of the fuel drain lines.

Each of the fuel drain lines combine together at the fuel return manifold. Some marine applications contain a fuel cooler within the sea water cooling circuit used to cool fuel before returning to the fuel tank. This fuel cooler is located between the fuel return manifold and the connection to the OEM fuel drain line.

Some engines are equipped with an electric fuel heater mounted between the fuel filter head and a spin-on canister. This fuel heater is actuated by either an internal sensor within the fuel filter heater, or by the electronic control module (ECM).

The electronic control module (ECM) controls the fueling and timing of the engine by actuating the solenoids on the injector. An electronic pulse is sent to the solenoids to lift the needle and start the injection event. By electronically controlling the injectors, there is a more precise and accurate control of fueling quantity and timing. Also, multiple injection events can be achieved by electronically controlling the injectors.

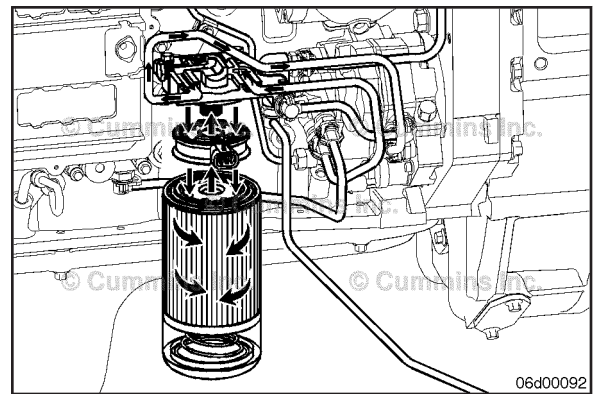

⚠️ WARNING ⚠️

The fuel pump, high-pressure fuel lines, and fuel rail contain very high-pressure fuel. Do not loosen any fittings while the engine is running. Personal injury and property damage can result. Wait at least 10 minutes after shutting down the engine before loosening any fittings in the high-pressure fuel system to allow pressure to decrease to a lower level.

⚠️ CAUTION ⚠️

Never exceed the maximum capacity of the gauge or flowmeter. Exceeding the maximum capacity will cause the gauge to read incorrectly. If the maximum is exceeded, check the gauge against a reference gauge.

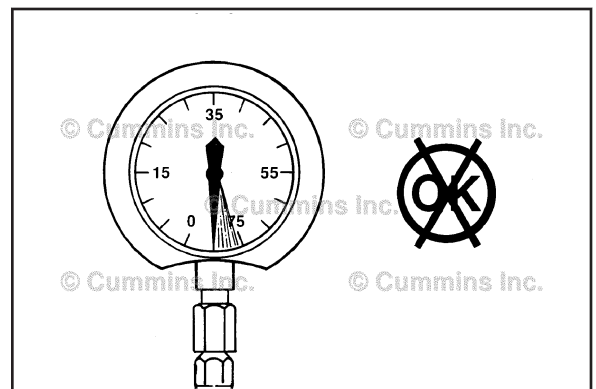



Lubricating Oil System - Overview (007-999)

General Information

⚠️ WARNING ⚠️

Some state and federal agencies have determined that used engine oil can be carcinogenic and can cause reproductive toxicity. Avoid inhalation of vapors, ingestion, and prolonged contact with used engine oil. If not reused, dispose of in accordance with local environmental regulations.

⚠️ WARNING ⚠️

To reduce the possibility of personal injury, avoid direct contact of hot oil with your skin.

Cummins Inc. recommends the use of a high-quality SAE 15W-40 heavy-duty engine oil, such as Cummins Premium Blue®, which meets the American Petroleum Institute (API) performance classification CI/SK.

NOTE: The SK designation is required for B series engines. This is due to the fact that all B series engines use sliding tappets.

NOTE: If CI/SK oils are **not** available, see the appropriate Operation and Maintenance manual for your engine for alternatives.

⚠ CAUTION ⚠

Limited use of low-viscosity lubricating oils, such as 10W-30, can aid in starting the engine and providing sufficient lubricating oil flow at ambient temperatures below -5°C [23°F] as shown in the illustration. However, the continuous use of low-viscosity lubricating oils can decrease engine life.

Oil flow through the engine enters the suction tube and travels into the gerotor-style lubrication pump. The oil is pressurized and fed into the oil cooler cover. Within the cover a pressure-regulating valve regulates the oil to 414 kPa [60 psi]. Excess oil is returned to the suction side of the lubricating oil pump for 3.9L and 5.9L engines and to the oil pan for 4.5L and 6.7L engines. Oil continues through the lubricating oil cooler to the lubricating oil filter bypass valve. The lubricating oil filter bypass valve will open if the pressure across the filter exceeds 345 kPa [50 psi]. Oil leaves the filter and supplies a line to the turbocharger, directed cooling nozzle rifle, and main oil rifle through a drilling between cylinders 1 and 2.

A main rifle runs the length of the block on the fuel pump side of the engine. The rifle supplies lubricating oil to the main bearings and crankshaft. Lubricating oil flows from the main bearings to the cam journals/bushings and piston-cooling nozzles, if equipped. The drilling in the crankshaft supplies lubricating oil to the rod bearings. Vertical drillings from the cylinder head deck to the main oil rifle supply oil to the cylinder head. Oil passes through the cylinder head gasket and enters the cylinder head. The drilling continues in the cylinder head to a drilling in the rocker lever pedestal. Internal drillings in the pedestal supply lubricating oil to the rocker shaft, push tube socket, and crosshead pad. A second main lubricating oil rifle runs the length of the cylinder block on the oil cooler side. This rifle supplies lubricating oil to the directed piston-cooling nozzles, if equipped.

When the diagnosing lubricating system malfunctions, check all obvious items related to oil pressure, such as gauges, high and low oil level, excessive oil contamination, and oil viscosity.

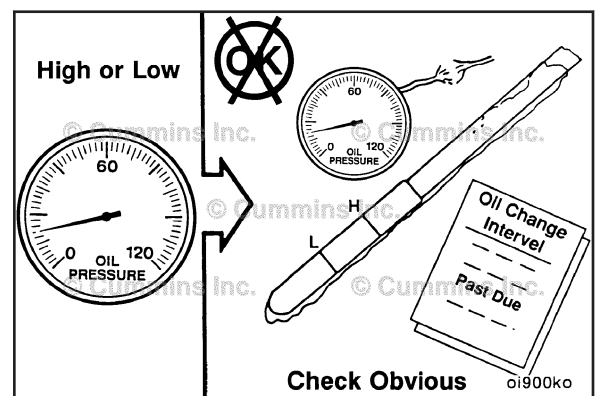
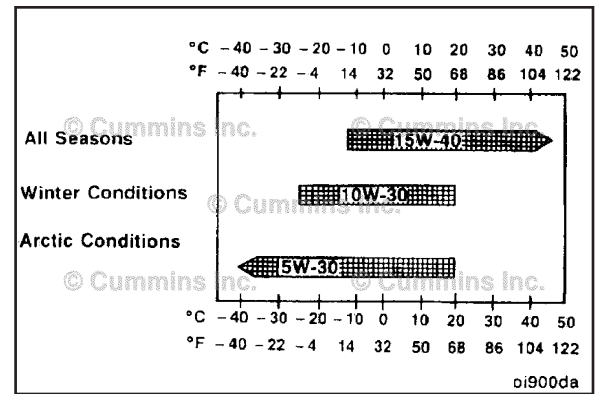

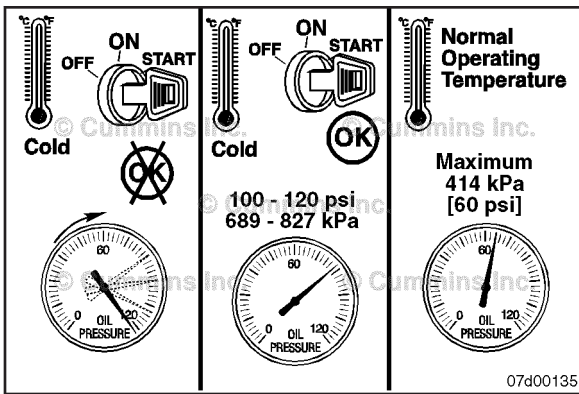

High lubricating oil pressure occurs after the engine is first started in cold weather. Cold-start oil pressure typically will be approximately 689 to 827 kPa [100 to 120 psi]. If the pressure regulator plunger is operating properly, the oil pressure should drop back to approximately 414 kPa [60 psi] when normal operating temperature is reached.

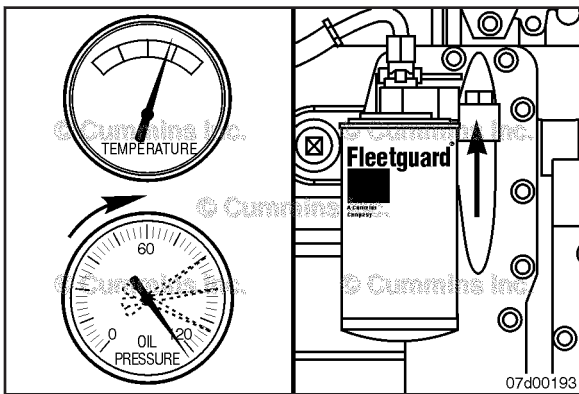

The engine will have high oil pressure at normal operating temperature if the lubricating oil pressure regulator valve sticks in the closed position.



Check the regulator for freedom of movement. Refer to Procedure Procedure 007-029

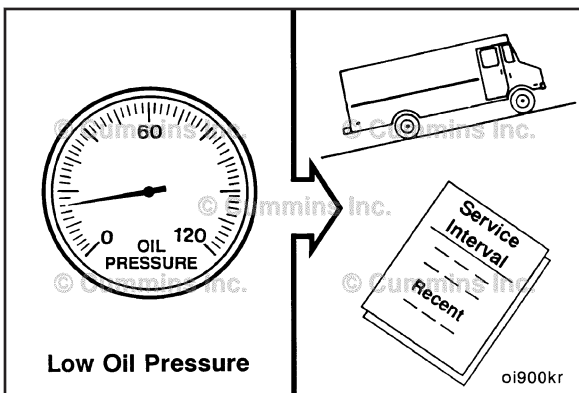

Low lubricating oil pressure (or no oil pressure) can be caused by several lubricating system-related malfunctions. To begin the investigation, determine the engine operating conditions when the low pressure was first observed. The following are conditions of low lubricating oil pressure:

- Following a service interval
- At idle **only**
- Operating on a steep grade
- Operating in rough sea.

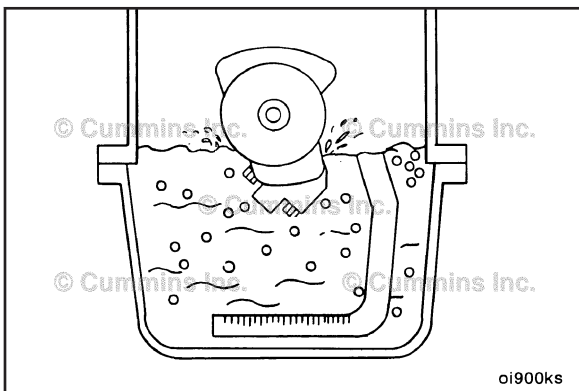

High lubricating oil level can cause low oil pressure. If the oil level is high enough for the connecting rods to dip into the oil while operating, the oil can become aerated, resulting in low oil pressure.

Low oil level will **not** normally appear as low oil pressure. Typically, it will appear as an intermittent loss of oil pressure when rounding a corner or operating on a steep grade. This condition exists when the oil level is extremely low and the suction tube can **not** pick up oil during all modes of operation.

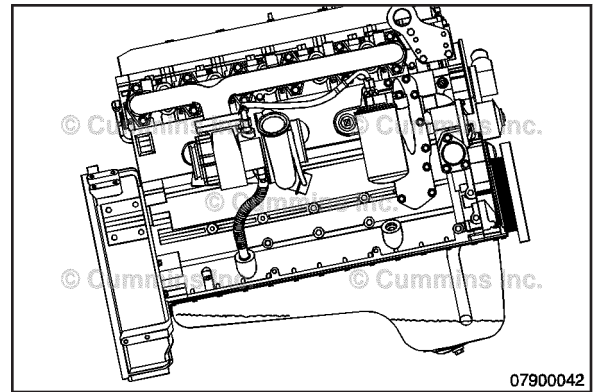

A plugged lubricating oil filter will cause a gradual loss of oil pressure by approximately 69 kPa [10 psi]. The pressure will return to normal when the filter bypass valve opens. If **not** corrected, this will result in severe engine wear, as the engine is running on unfiltered oil when the bypass valve is open.

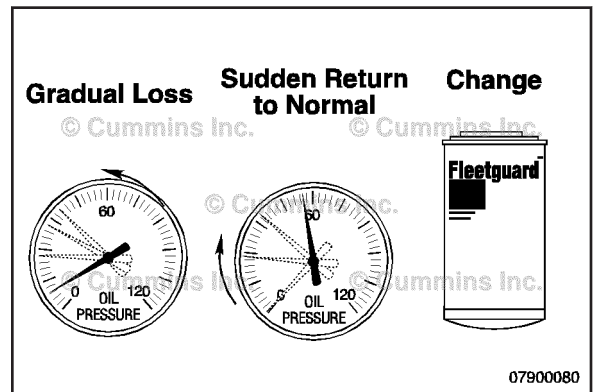

Check the lubricating oil gauge and sending unit to make sure they are operating correctly by verifying the pressure with a manual gauge.

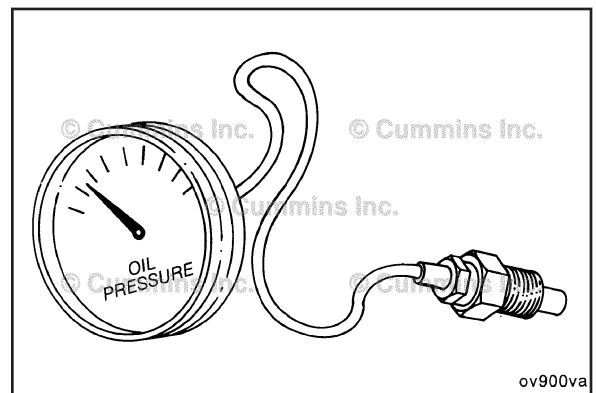

A loose lubricating oil suction tube, damaged gasket, or crack in the suction tube can cause a loss of prime for the oil pump. The engine will have low pressure or no oil pressure during starting, followed by normal oil pressure.

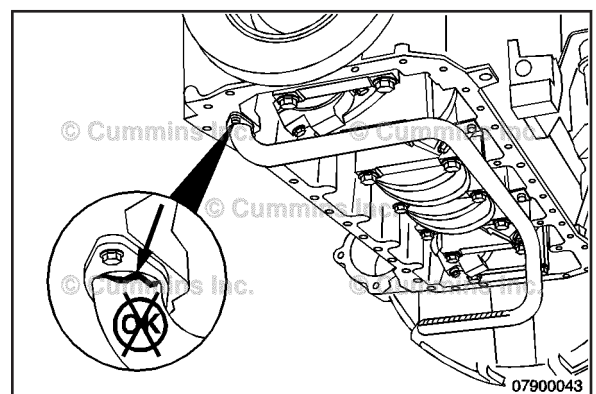

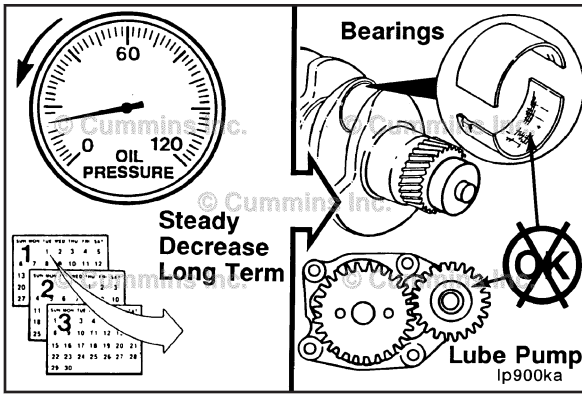

A steady decrease in oil pressure over a long period can be an indication of worn bearings or excessive lubricating oil pump wear.

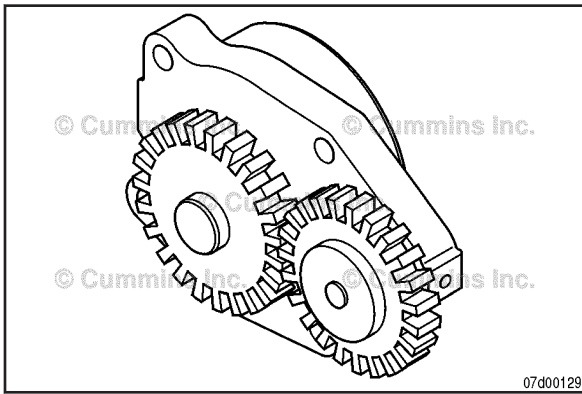

Though similar in design and appearance, there are many variations of the lubricating oil pump. Before installing a new lubricating oil pump make sure that the pump is correct for you engine.



Refer to Procedure Procedure 007-031 for removal and installation procedures. See Quickservice Online to determine the correct lubricating oil pump part number.

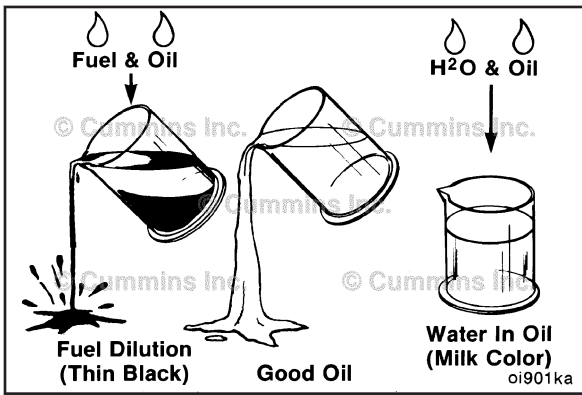

CAUTION
Using diluted oil can cause severe engine damage.

Check the condition of the lubricating oil:

- Thin, black oil is an indication of fuel in the oil
- Milky discoloration is an indication of coolant in the oil.

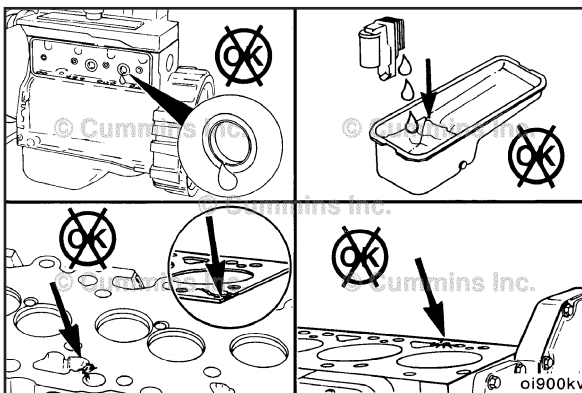

Coolant in the oil can be caused by:

- Expansion plugs leaking
- Oil cooler element leaking
- Damaged cylinder head or gasket
- Cracked engine block
- Casting porosity.

Since the lubricating oil cooler design does **not** require gaskets or seals to maintain the separation of oil and coolant, the element itself **must** leak to allow mixing of the fluids. Refer to Procedure Procedure 007-003

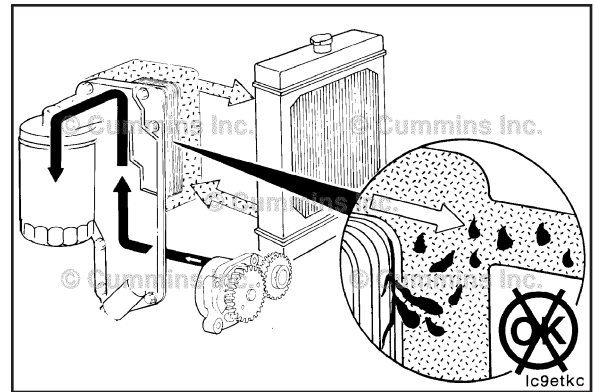

While operating, the oil pressure will be higher than coolant pressure. A leak in the oil cooler will show as oil in the coolant.



However, following an engine shutdown, the residual pressure in the coolant system can cause coolant to seep through the leak path into the oil.

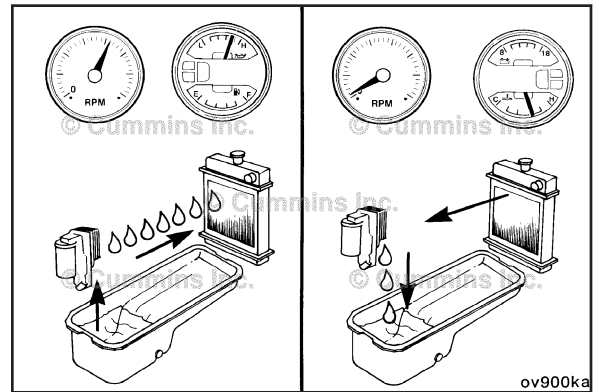

If the oil cooler element ruptures, the oil pressure will force oil into the coolant system.



Oil in the coolant should be visible when the radiator cap is removed. Refer to Procedure Procedure 007-003

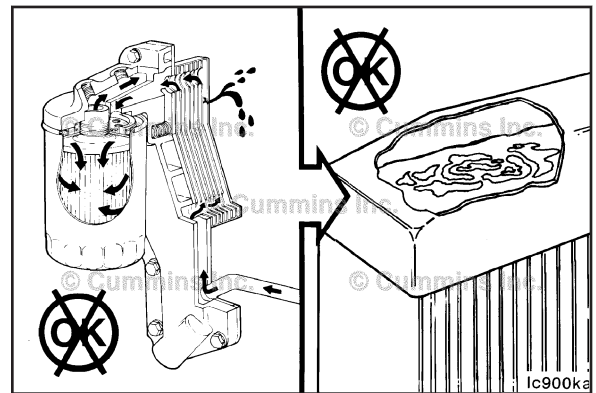

To check for leaks, pressurize the cooling system to 140 kPa [20 psi]. With the system pressurized, remove the following components and inspect for leaks:



- Rocker lever cover. Refer to Procedure Procedure 003-011. Leaks indicate a cracked cylinder head.
- Lubricating oil drain plug. Refer to Procedure Procedure 007-037. Leaks indicate defective oil cooler, cylinder head gasket, or cracked cylinder head or block.

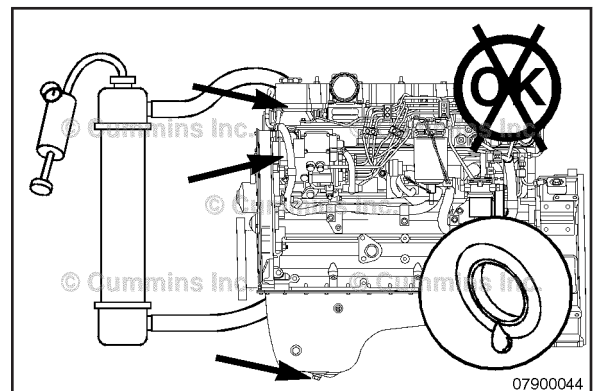

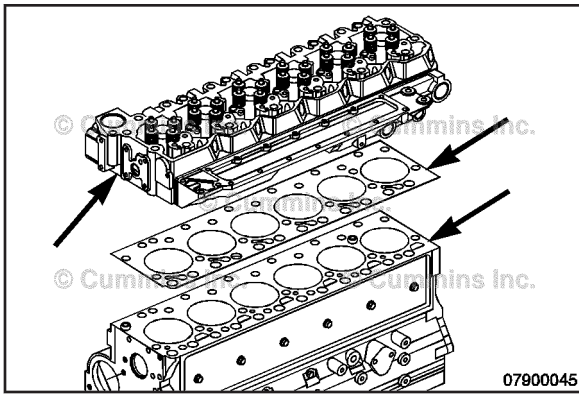

Coolant in the lubricating oil can be caused by a damaged cylinder head gasket or cracked cylinder head or block.



Remove the cylinder head and gasket. Refer to Procedure 002-004

Inspect for cracks or any other damage.

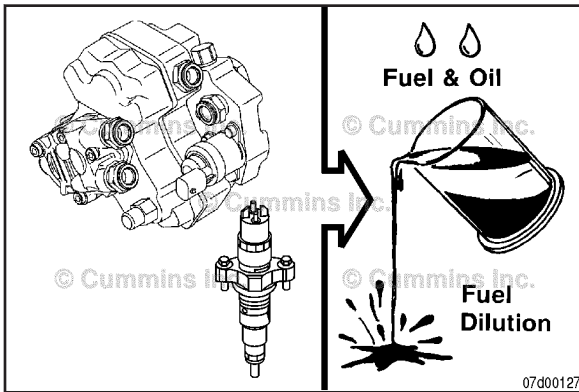

Fuel dilution of the lubricating system is generally due to the injector but may also be due to internal damage to the high-pressure pump.

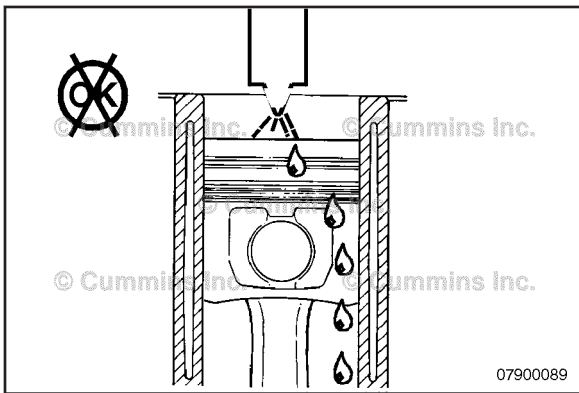

Incomplete combustion in the cylinders can result in unburned fuel draining into the oil pan.

This condition can be caused by a leaking injector or reduced compression caused by inadequate piston ring sealing.

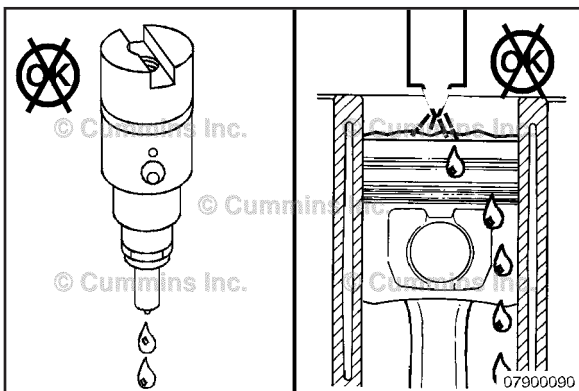

An increase in white exhaust smoke during the first start of the day is a symptom that an injector is leaking.

An injector leak will also cause the engine to run rough and have low power.



Remove and repair, or replace leaking injectors. Refer to Procedure Procedure 006-026



The o-rings in the injectors can be inspected for cracks or wear. A missing or damaged o-ring in an injector can result in improper disbursement of fuel into the cylinder.

Also, a poor seal between the injector and the high-pressure transfer tube can also cause the injector o-rings to fail or leak into the top of the cylinder head.

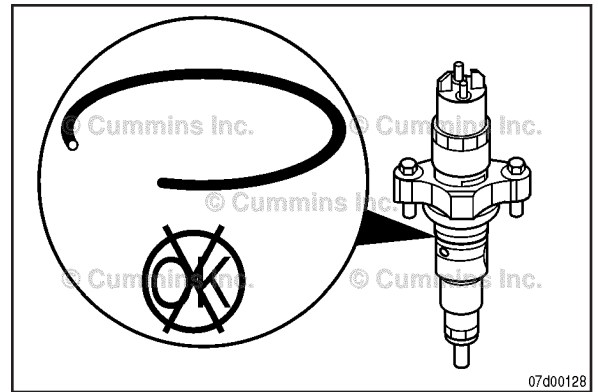

Inspect the injector o-ring. Refer to Procedure 006-026

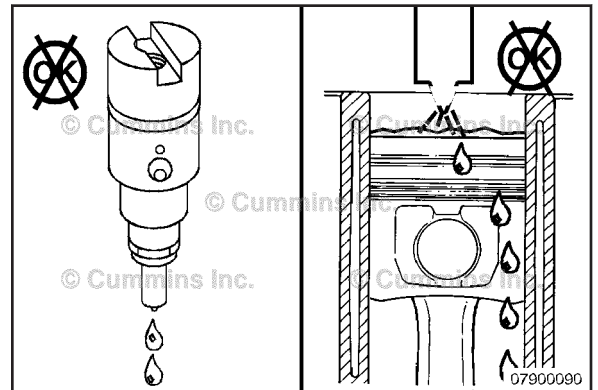

Various gaskets, seals, and plugs are used to contain the lubricating oil. Most leaks can be identified during routine inspections of the engine and vehicle.

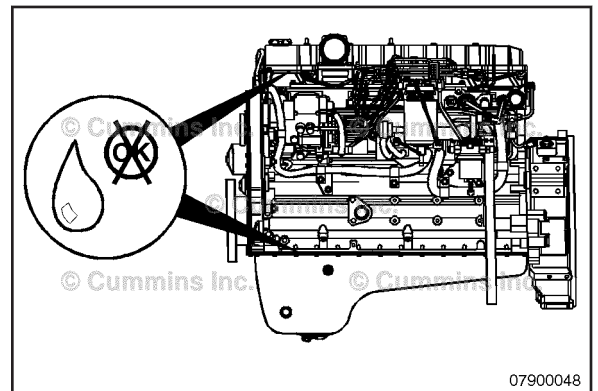

Worn or damaged seals in the turbocharger can also allow oil to leak into the charge air cooler system and be burned in the engine.

The condition can be verified by removing the air crossover tube or charge air cooler tubing and looking for oil. Refer to Procedure Procedure 010-019 and Refer to Procedure Procedure 010-027

NOTE: If the engine experiences a turbocharger failure or any other occasion where oil or debris is put into the charge air cooler, the charge air cooler **must** be cleaned.

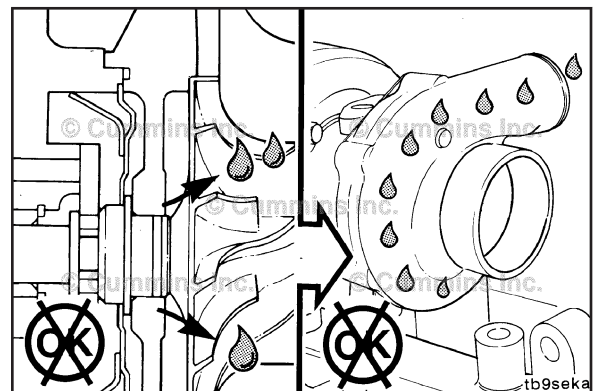

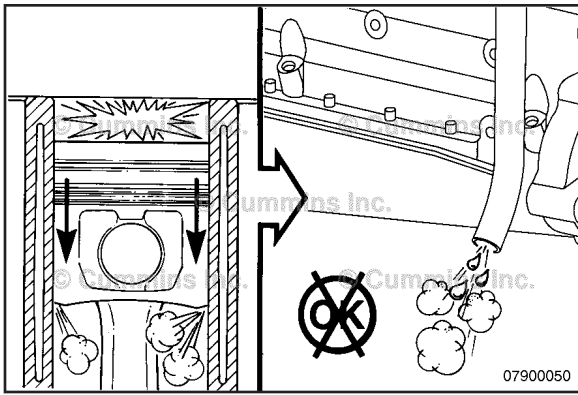

Inadequate sealing of the piston rings will result in oil being blown out the breather tube and/or consumed by the engine. Refer to Procedure Procedure 014-010

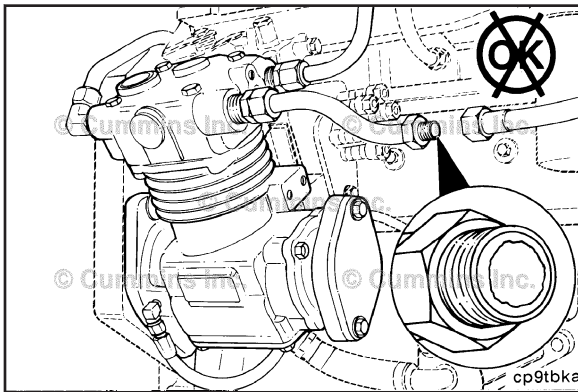

Lubricating oil can also be lost through a worn or malfunctioning air compressor. Look for carbon buildup in the air line from the compressor to the air tank.

Also, a failed air compressor head gasket or cylinder head gasket can allow oil to leak into the coolant or coolant to leak into the oil during a hot shutdown.

Flow Diagram, Lubricating Oil System (200-002)

General Information

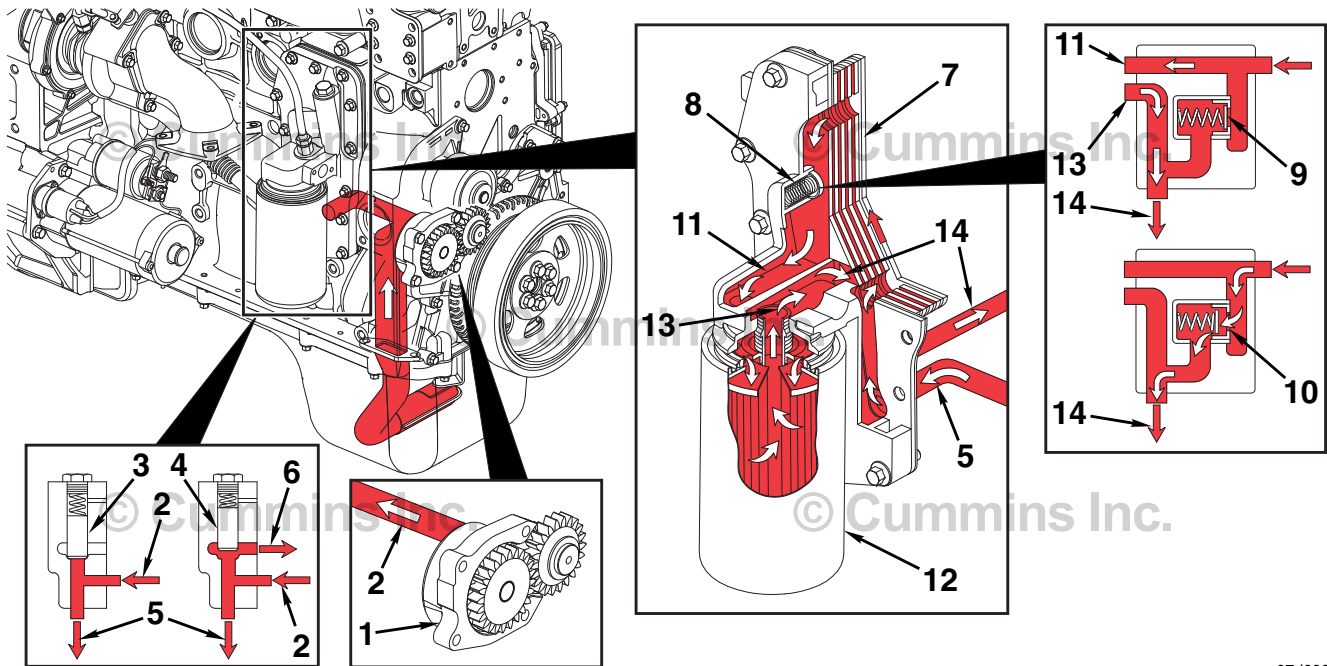

- 1 Gerotor lubricating oil pump
- 2 From lubricating oil pump
- 3 Pressure regulating valve closed
- 4 Pressure regulating valve open
- 5 To lubricating oil cooler
- 6 To lubricating oil pump supply
- 7 Lubricating oil cooler
- 8 Filter bypass valve
- 9 Filter bypass valve closed
- 10 Filter bypass valve open
- 11 To lubricating oil filter
- 12 Full-flow lubricating oil filter
- 13 From lubricating oil filter
- 14 Main lubricating oil rifle.

07d00073

Flow Diagram, Lubricating Oil System (200-002)

General Information

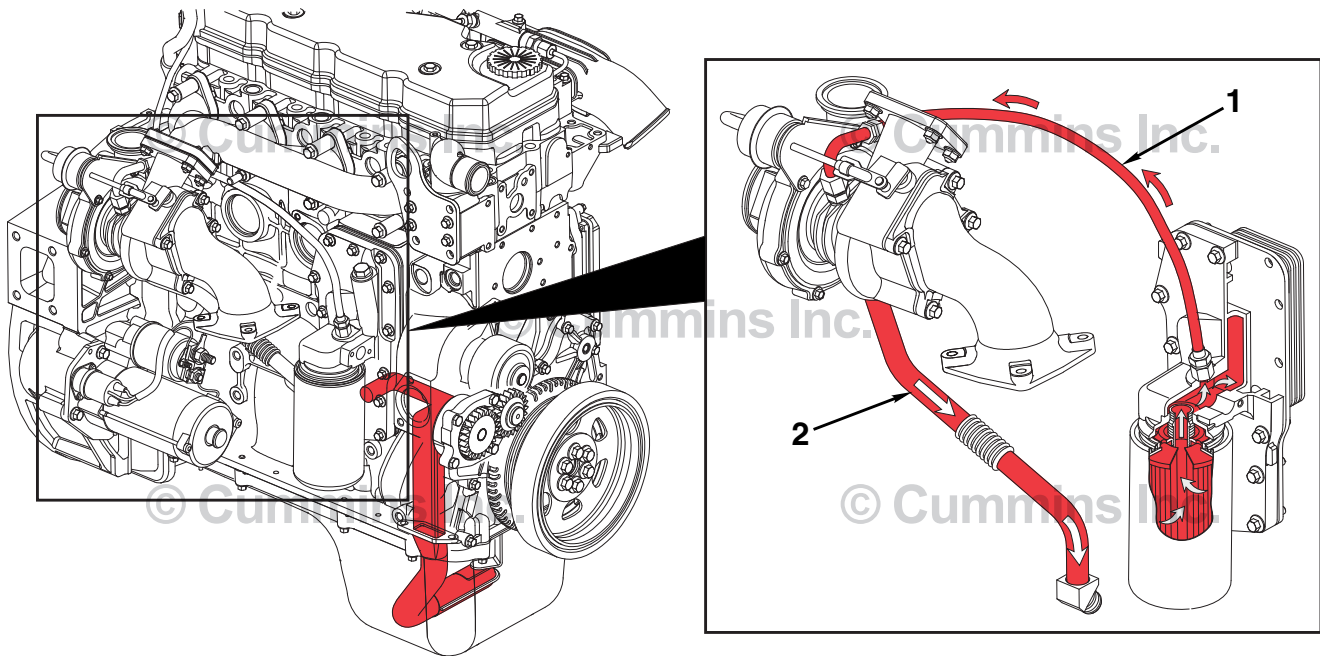

07d00074

Lubrication for the Turbocharger, Non Marine Engines

- 1 Turbocharger lubricating oil supply
- 2 Turbocharger lubricating oil drain.

Flow Diagram, Lubricating Oil System (200-002)

General Information

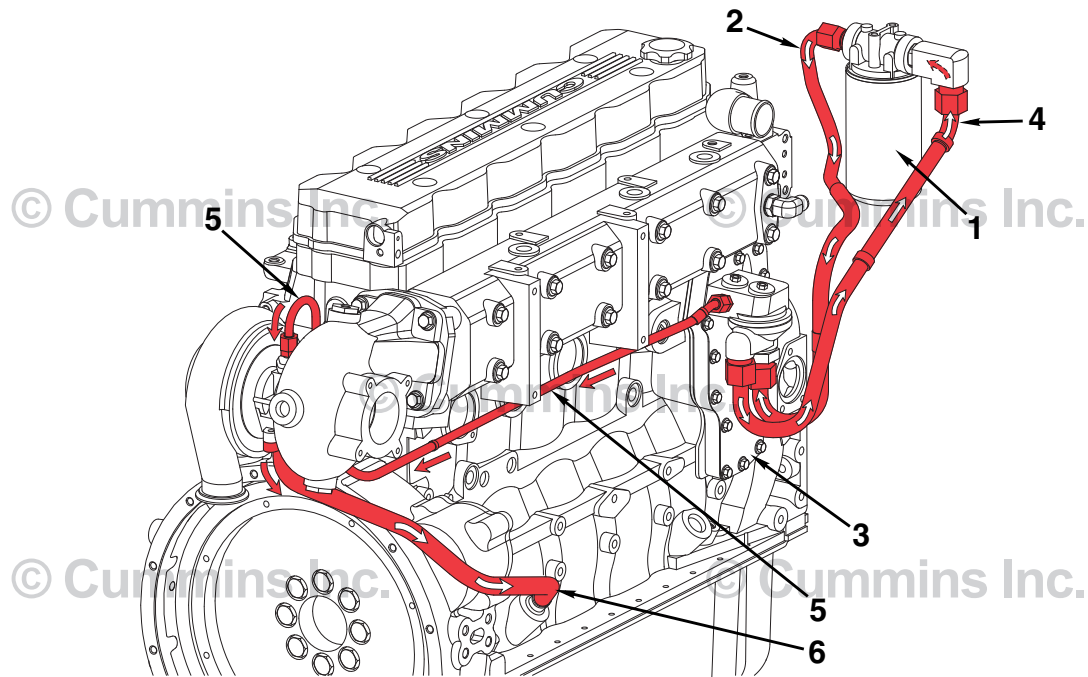

Lubrication for the Turbocharger and Oil Filter, Marine Engines

- 1 Lubricating oil filter
- 2 Filtered oil supply to main oil rifle
- 3 Lubricating oil cooler
- 4 Unfiltered lubricating oil to filter
- 5 Turbocharger lubricating oil supply
- 6 Turbocharger lubricating oil drain.

07d00192

Flow Diagram, Lubricating Oil System (200-002)

General Information

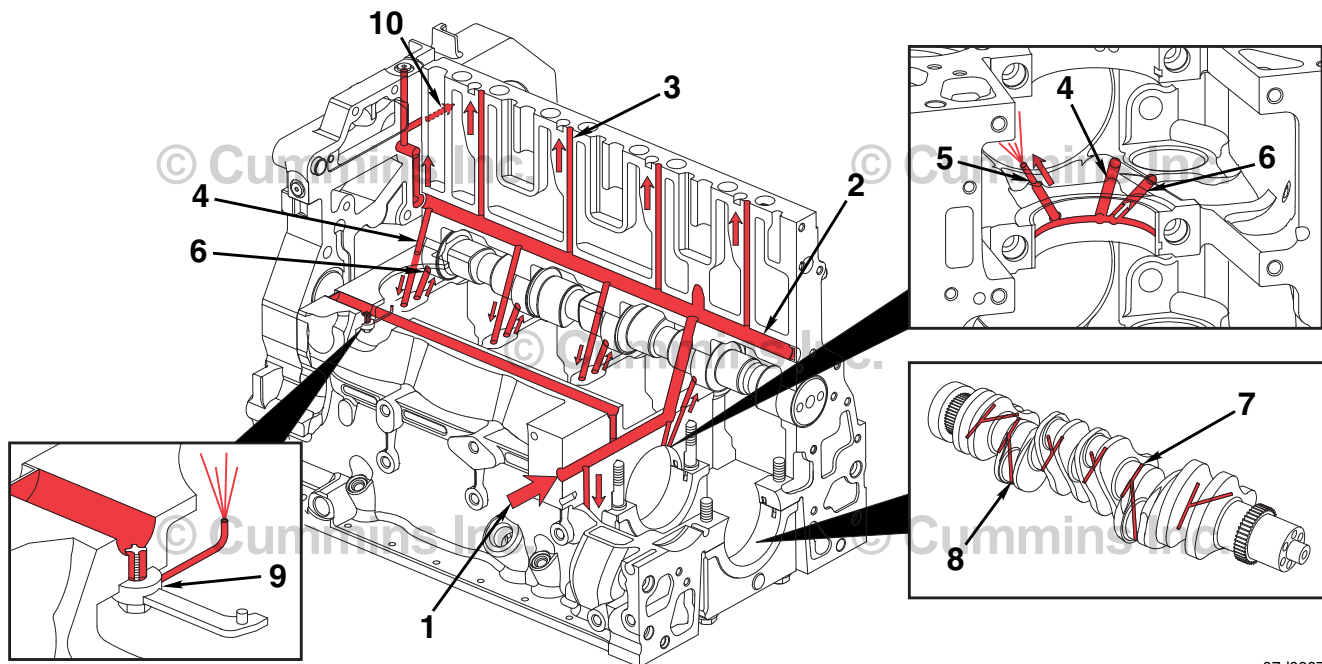

07d00075

Lubrication for the Power Components

- 1 From lubricating oil cooler
- 2 Main lubricating oil rifle
- 3 To valve train
- 4 From main lubricating oil rifle
- 5 To piston-cooling nozzle
- 6 To camshaft
- 7 Crankshaft main journal
- 8 Oil supply to rod bearings
- 9 Directed piston-cooling nozzle
- 10 To internal lubrication of air compressor.

Flow Diagram, Lubricating Oil System (200-002)

General Information

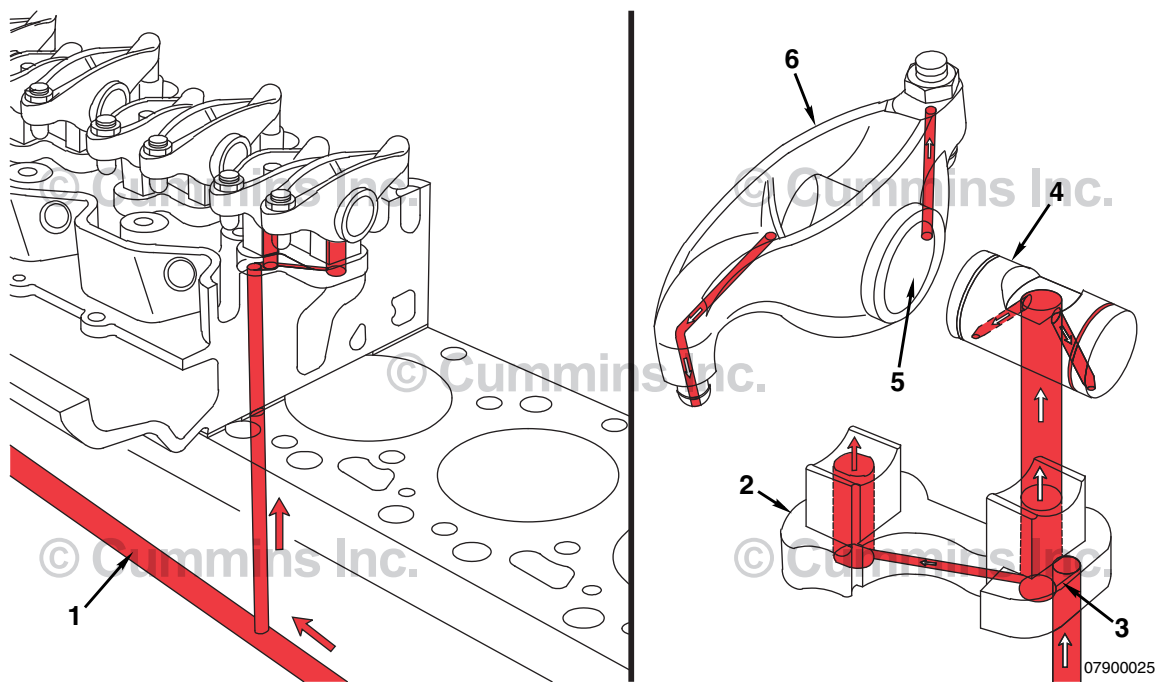

Lubrication for the Overhead Components

- 1 Main lubricating oil rifle
- 2 Rocker lever support
- 3 Transfer slot
- 4 Rocker lever shaft
- 5 Rocker lever bore
- 6 Rocker lever.

Flow Diagram, Lubricating Oil System (200-002)

General Information

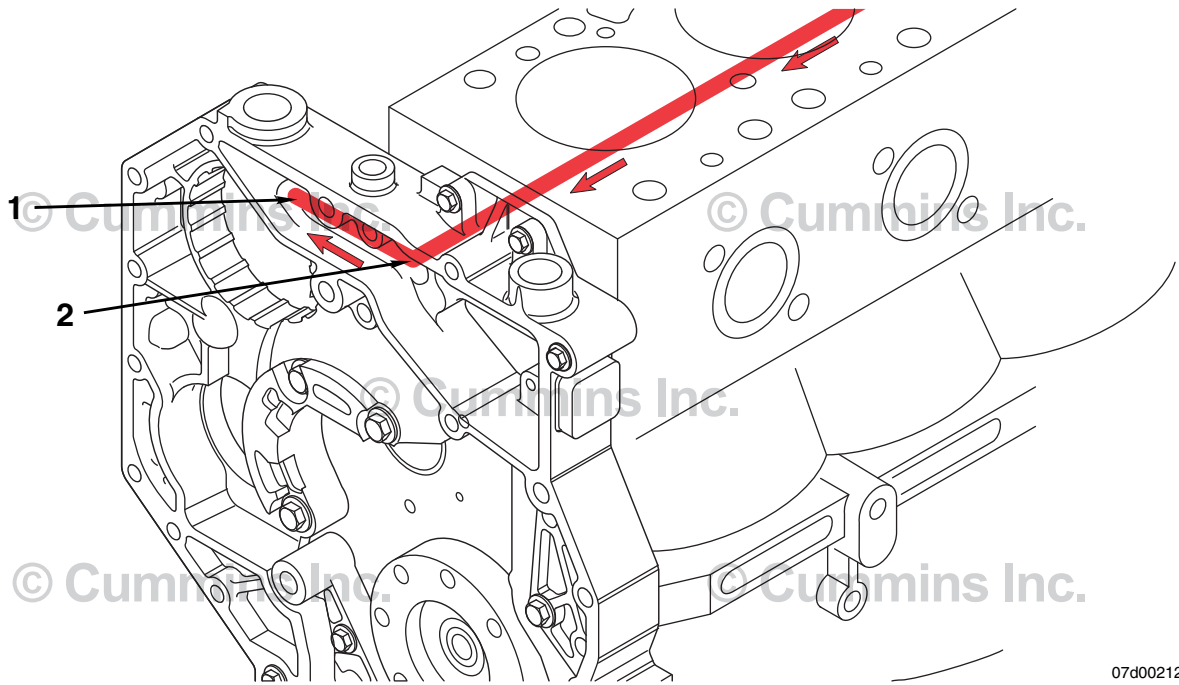

Lubrication for the Accessory Drive

- 1 Oil feed from block
- 2 Oil supply to accessory drive.

NOTE: Oil returns to pan through the gear housing.

07d00212

Cooling System - Overview (008-999)

General Information

The function of the cooling system is to maintain a specified operating temperature for the engine. Some of the heat generated by the engine is absorbed by the engine coolant flowing through the passages in the cylinder block and cylinder head. Heat is then removed from the engine coolant as it flows through the radiator.

Engine coolant is drawn into an integral water pump and is pressurized. Engine coolant first flows around the oil cooler plates and enters a cavity around the cylinders. Engine coolant flow continues through holes in the top deck through orifices in the cylinder head gasket. These drillings are around and between each cylinder. Engine coolant flows into the cylinder head and around the valve bridge and injector areas. Engine coolant continues to the exhaust side of the cylinder head past the OEM port locations and to the integral thermostat housing. Before the engine reaches thermostat opening temperature, a bypass port is open to allow engine coolant to enter the suction side of the water pump. Once the engine reaches the thermostat opening temperature, the thermostat opens, allowing the engine coolant to enter the radiator. This action also closes the bypass passage to the water pump.

On engines with EGR, the vent pipe plug located in the EGR cooler bundle return **must** be removed any time the engine is filled with coolant.

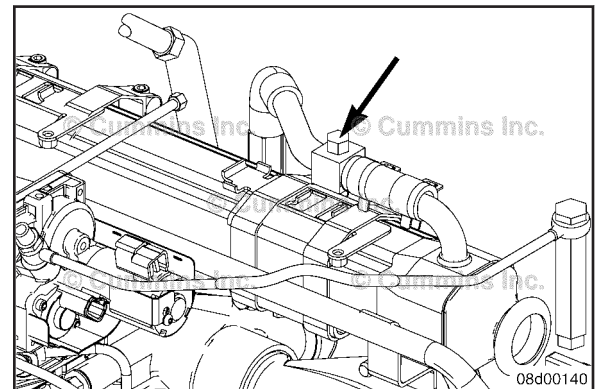
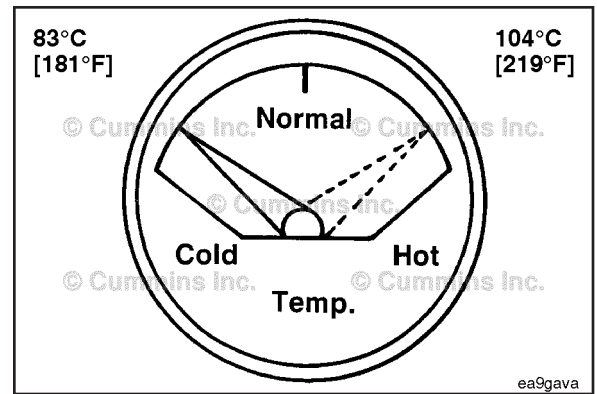

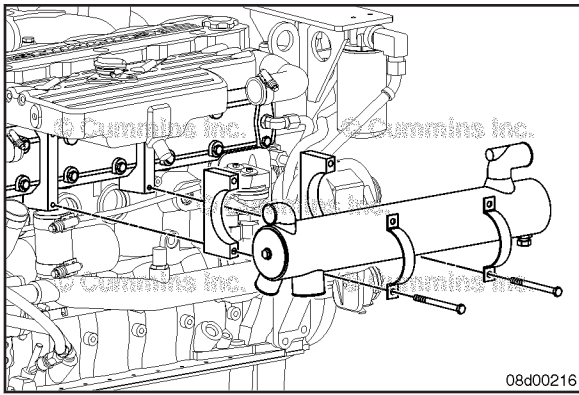

The marine heat exchanger is a two pass, tube design and is located on the exhaust side of the engine. The end cover plates are removable for cleaning the tubes; the cooler bundle is **not** removable. A sacrificial plug is located in the front cavity of the heat exchanger sea water passage.

The engine coolant flows from the thermostat housing outlet into the top front of the heat exchanger and is directed over the tubes by baffles. The engine coolant exits the cooler at the bottom rear of the heat exchanger. The engine coolant is then returned to the engine coolant pump inlet via a transfer tube.

The cooling sea water enters the bottom rear of the heat exchanger cavity and is diverted to the lower half of the cooler tubes by a divider plate in the cavity. The sea water flows through the tubes to the front, nondivided cavity. The sea water then flows through the tubes on the upper half of the cooler and is discharged out of the top rear of the heat exchanger, and into the outer shell of the exhaust elbow. The sea water is then discharged overboard.

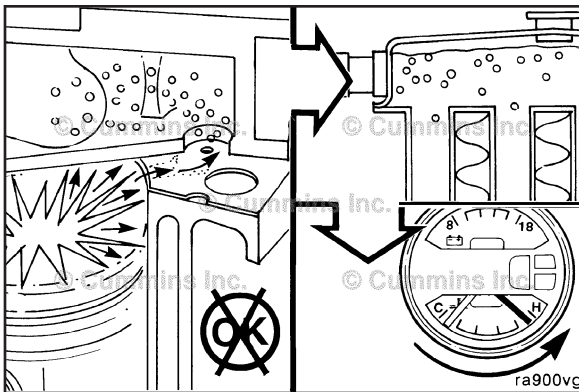

Air in the coolant can result in loss of coolant from the overflow when the aerated coolant is hot. The heated air expands, increasing the pressure in the system, causing the cap to open.

Similarly, coolant can be displaced through the overflow if the head gasket leaks compression gas into the coolant system.

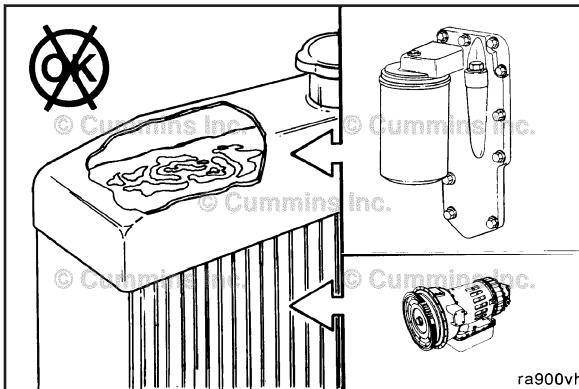

The operating pressure of the coolant system and the lubricating system can result in the mixing of the fluids if there is a leak between the systems, such as the head gasket or oil cooler. Refer to Procedure 007-999 (Lubricating Oil System- Overview).



NOTE: Transmission fluid can also leak into the coolant through radiator bottom tank transmission oil coolers.

Flow Diagram, Cooling System (200-003)

Flow Diagram

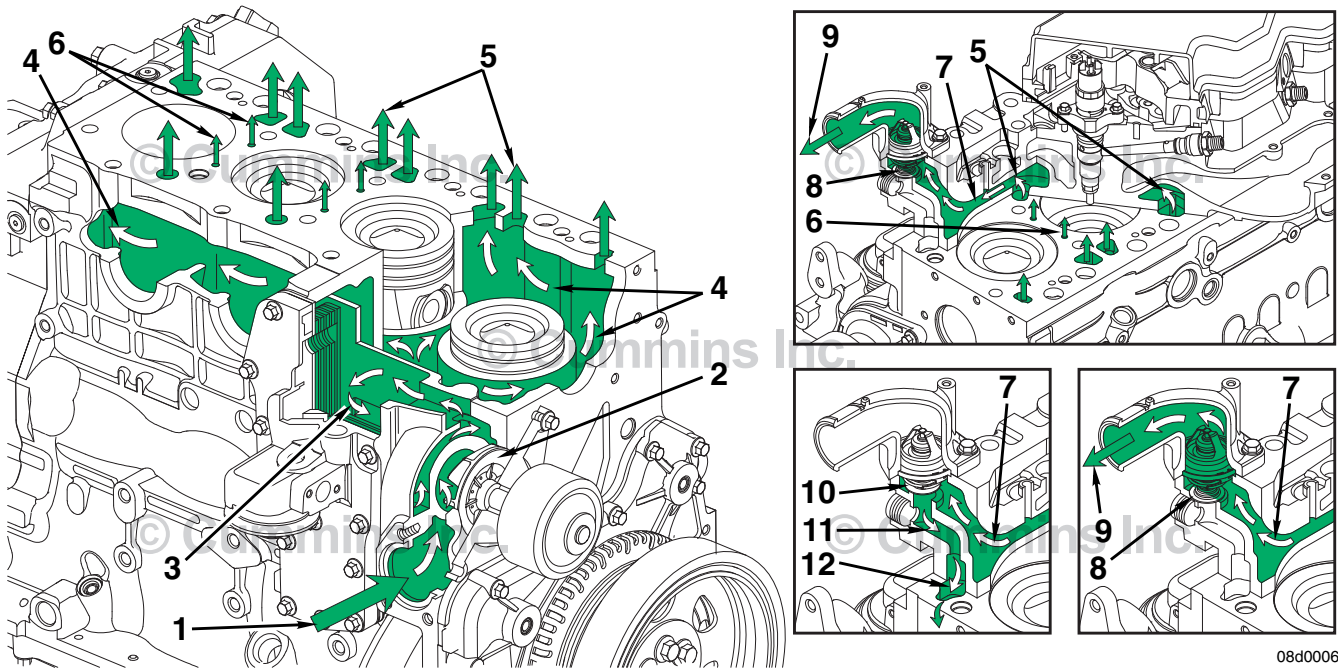

08d00066

Automotive and Industrial without EGR

- 1 Coolant inlet
- 2 Pump impeller
- 3 Coolant flow past lubricating oil cooler
- 4 Coolant flow past cylinders
- 5 Coolant flow from cylinder block to cylinder head
- 6 Coolant flow between cylinders (engines **without** EGR only)
- 7 Coolant flow to thermostat housing
- 8 Coolant bypass passage
- 9 Coolant flow back to radiator
- 10 Bypass open
- 11 Coolant bypass in cylinder head
- 12 Coolant flow to water pump inlet.

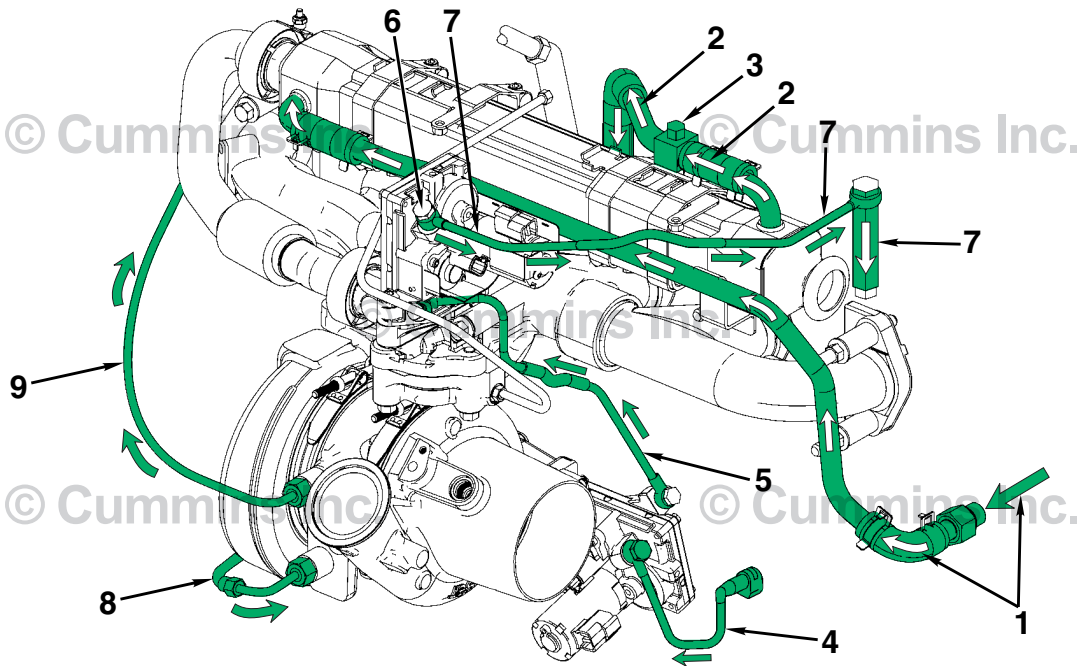

08d00138

Automotive Engines with EGR

- 1 Coolant flow from cylinder block to EGR cooler inlet
- 2 Coolant flow from EGR cooler returning back to cylinder head
- 3 Vent plug used for cooling system fill
- 4 Coolant flow from cylinder block to VGT actuator inlet
- 5 Coolant flow from VGT actuator to EGR valve inlet
- 6 M10 vented banjo - vent orifice to surge tank
- 7 Coolant flow return from EGR valve back to cylinder head
- 8 Coolant flow from cylinder block to turbocharger bearing housing
- 9 Coolant flow return from turbocharger bearing housing back to the rear of the cylinder head.

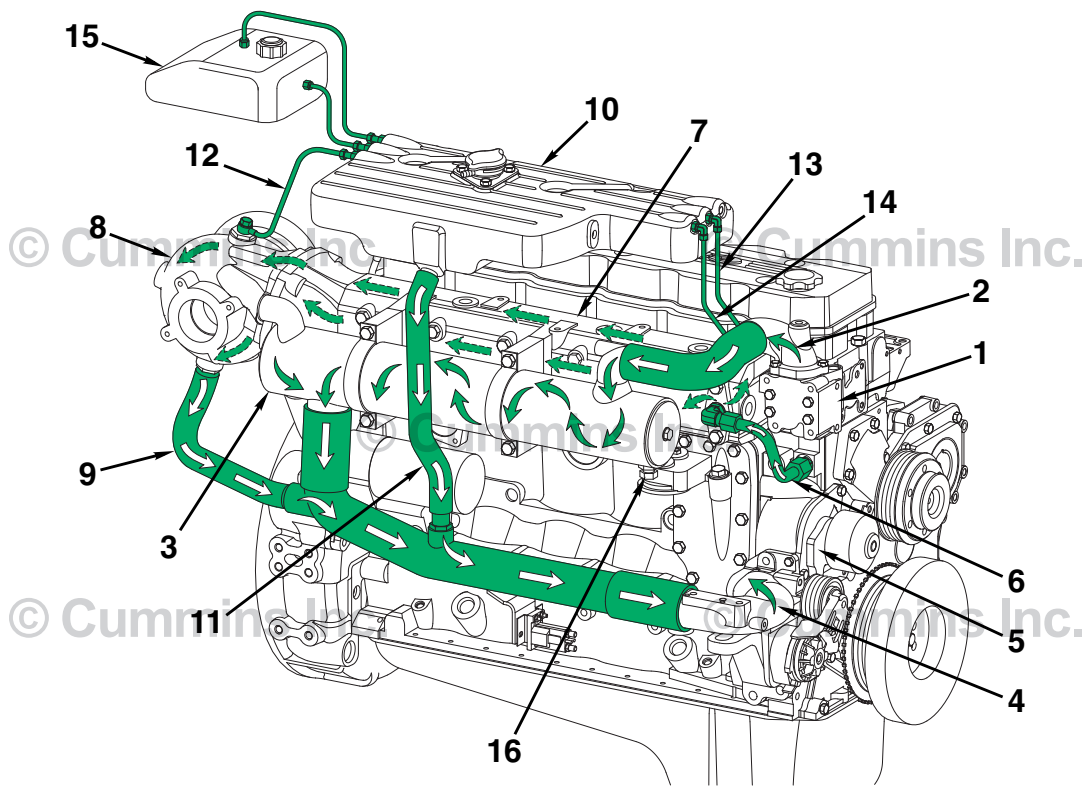

Engine Coolant Flow

08d00164

- 1 Thermostat housing
- 2 Coolant outlet
- 3 Heat exchanger
- 4 Coolant inlet to water pump
- 5 Water pump
- 6 Coolant supply to exhaust manifold
- 7 Exhaust manifold (wet)
- 8 Turbocharger (water cooled)
- 9 Coolant discharge from turbocharger
- 10 Expansion tank
- 11 Coolant make-up line
- 12 Turbocharger vent line
- 13 Cylinder head vent line
- 14 Exhaust manifold vent line
- 15 Coolant recovery bottle
- 16 Heat exchanger zinc anode.

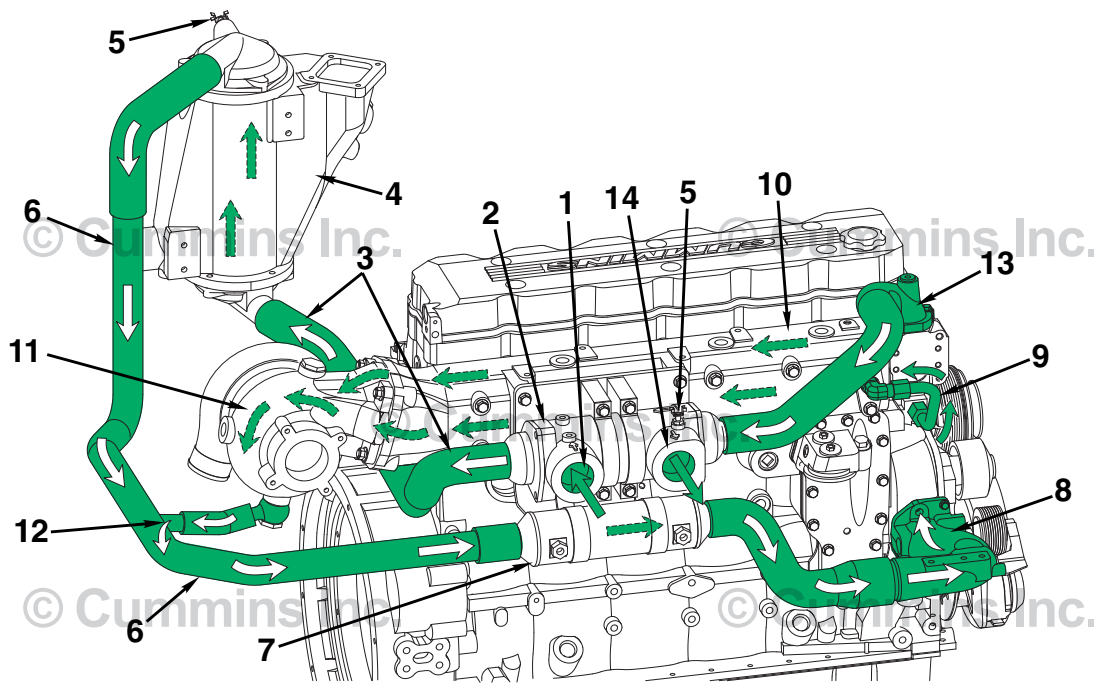

Engine Coolant Flow, Keel Cooled (Exhaust Side)

- 1 Coolant Inlet from Keel Cooler
- 2 Thermostat Housing for Keel Cooling
- 3 Coolant Inlet from Thermostat Housing to Aftercooler
- 4 Aftercooler
- 5 Engine Cooling System Fill Vent Petcock
- 6 Coolant Outlet from Aftercooler to Marine Gear Cooler
- 7 Marine Gear Cooler
- 8 Coolant Inlet to Water Pump
- 9 Engine Coolant Outlet to Exhaust Manifold
- 10 Water Cooled Exhaust Manifold
- 11 Turbocharger with Water Cooled Turbine Housing
- 12 Turbocharger Coolant Outlet
- 13 Engine Coolant Outlet to Thermostat Housing
- 14 Coolant Outlet to Keel Cooler.

00900429

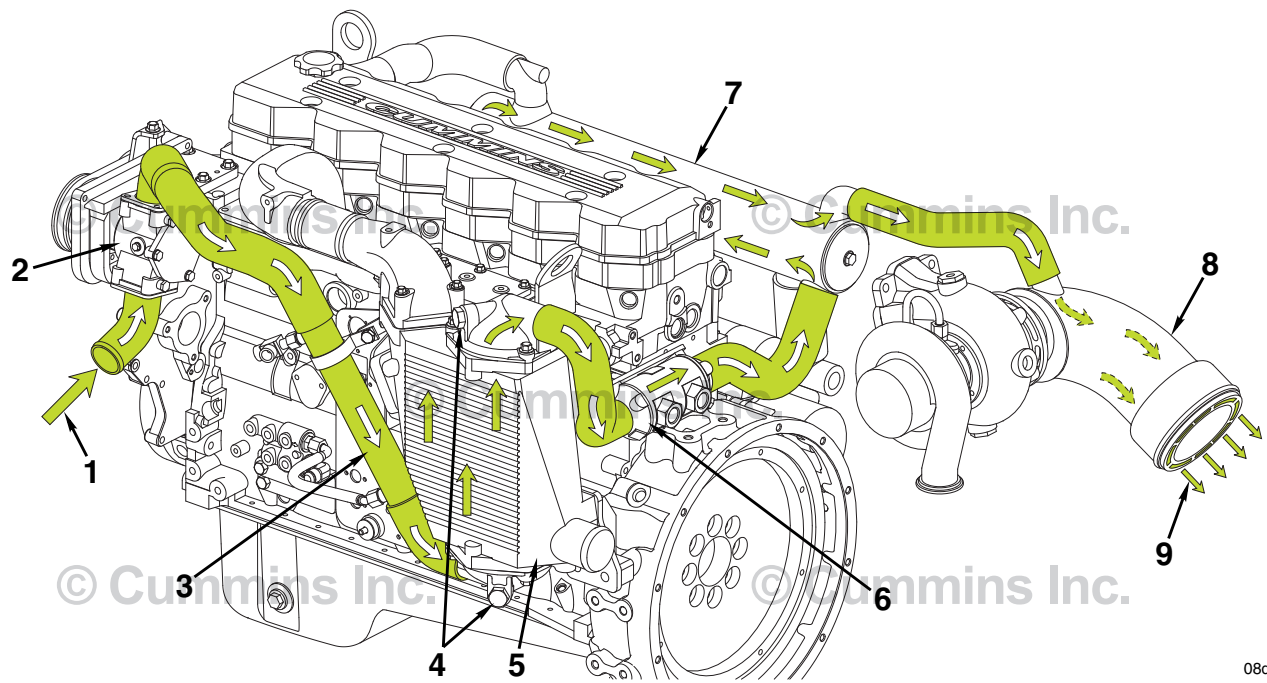

Sea Water Coolant Flow

- 1 Sea water supply
- 2 Sea water pump
- 3 Fuel cooler
- 4 Aftercooler zinc anode
- 5 Aftercooler housing
- 6 Marine gear oil cooler
- 7 Heat exchanger
- 8 Exhaust outlet
- 9 Sea water discharge

08d00163

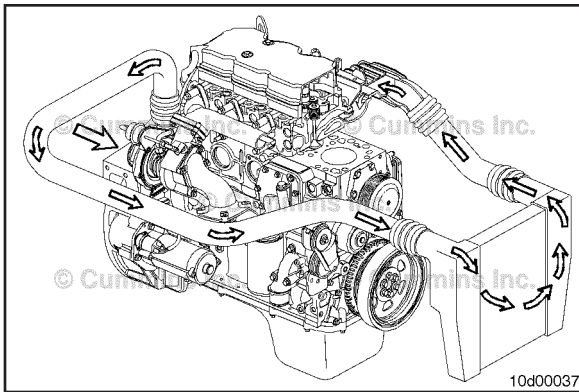

Air Intake System - Overview (010-999) General Information

Engines without EGR

The combustion air system on engines without EGR consists of the following:

- Air cleaner
- Intake air piping
- Turbocharger
- Charge air piping
- Charge air cooler
- Exhaust manifold
- Intake air heater.

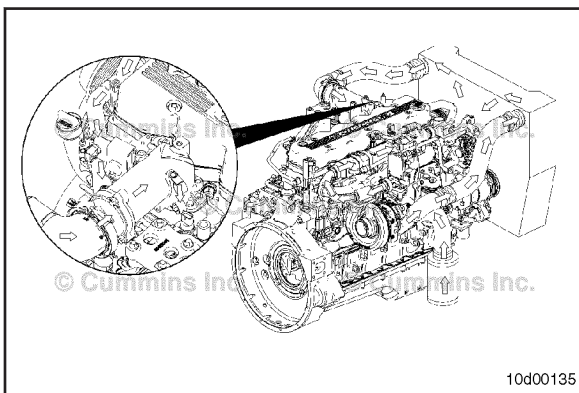

Engines with EGR

The combustion air system on engines with EGR consists of the following:

- Air cleaner
- Intake air piping
- Turbocharger
- Charge air piping
- Charge air cooler
- Exhaust manifold
- Intake air heater
- Exhaust gas recirculation.

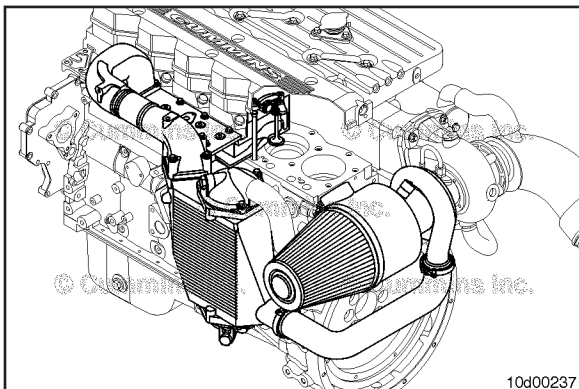

Marine Engines

The combustion air system on Marine engines consists of the following:

- Air cleaner with oil separator system
- Water-cooled turbocharger
- Aftercooler
- Air piping
- Wet exhaust manifold.

Engines without EGR

Air is drawn through the air cleaner into the compressor side of the turbocharger. It is then forced through the charge air cooler piping to the charge air cooler, the intake air heater (if applicable), and into the intake manifold. From the intake manifold, air is forced into the cylinders and used for combustion.

- 1 Intake air inlet to turbocharger
- 2 Turbocharger air to charge air cooler
- 3 Charge air cooler
- 4 Intake manifold
- 5 Intake valve.

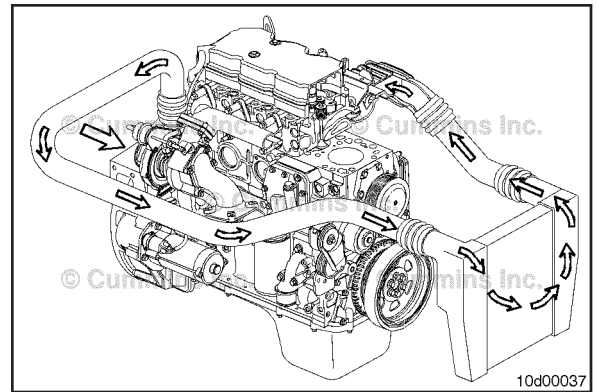

Engines with EGR

Air is drawn through the air cleaner into the compressor side of the turbocharger. It is then forced through the charge air cooler piping to the charge air cooler, mixed with EGR gas, through the intake air heater, and into the intake manifold. From the intake manifold, air is forced into the cylinders and used for combustion.

- 1 Intake air inlet to turbocharger
- 2 Turbocharger air to charge air cooler
- 3 Charge air cooler
- 4 EGR mixer
- 5 Intake manifold
- 6 Intake valve.

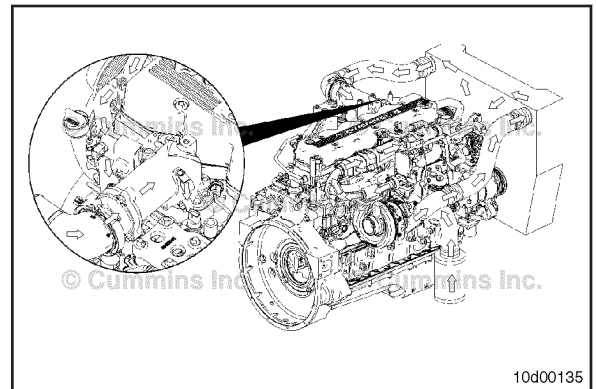

Marine Engines

Air is drawn through the air cleaner into the compressor side of the turbocharger. It is then forced through the air piping to the aftercooler, through the air piping and into the intake manifold. From the intake manifold, air is forced into the cylinders and used for combustion.

- 1 Intake air inlet to turbocharger
- 2 Turbocharger air to aftercooler
- 3 Aftercooler
- 4 Intake manifold
- 5 Intake valve.

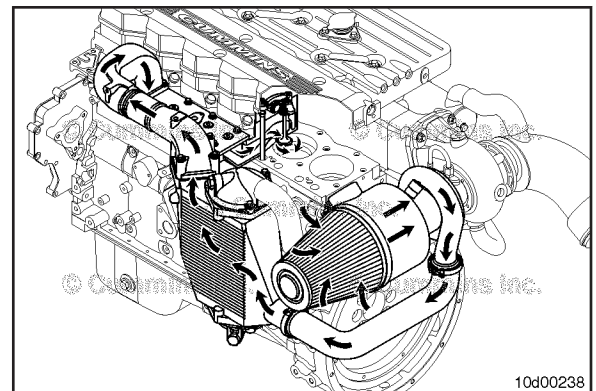

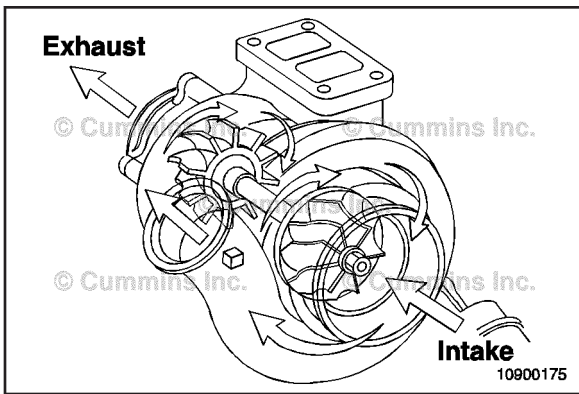

The turbocharger uses exhaust gas energy to turn the turbine wheel. The turbine wheel drives the compressor impeller, which provides pressurized air to the engine for combustion. The additional air provided by the turbocharger allows more fuel to be injected to increase the power output from the engine.

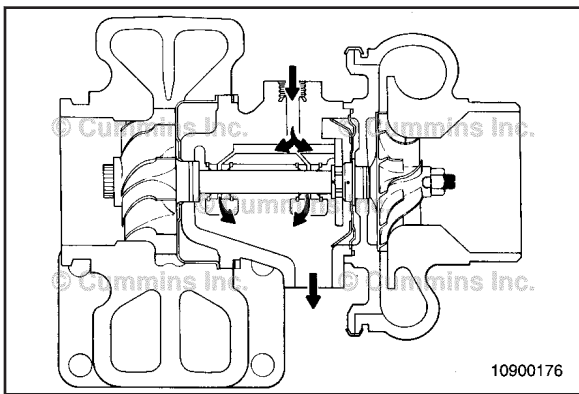

The turbine and compressor wheels share a common shaft (referred to as a rotor assembly), which is supported by two rotating bearings in the bearing housing. Passages in the bearing housing direct filtered, pressurized engine oil to the shaft bearings and thrust bearings. The oil is used to lubricate and cool the rotating components. Oil then drains from the bearing housing to the engine sump through the oil drain line.

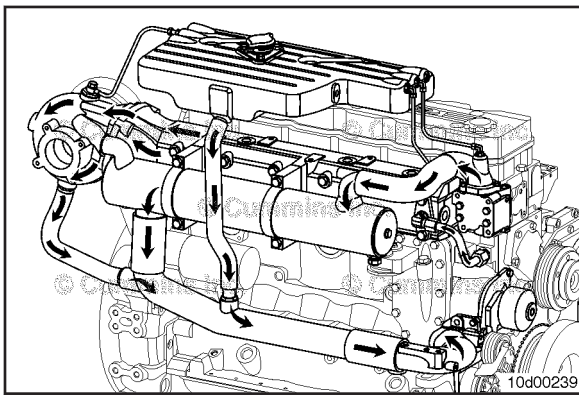

Marine Engines

Marine engines utilize a non-wastegate, water-cooled turbocharger. Jacket water is supplied to the turbocharger turbine housing through the wet exhaust manifold and returned to the suction side of the engine coolant pump. The turbocharger coolant is vented directly to the engine mounted expansion tank.

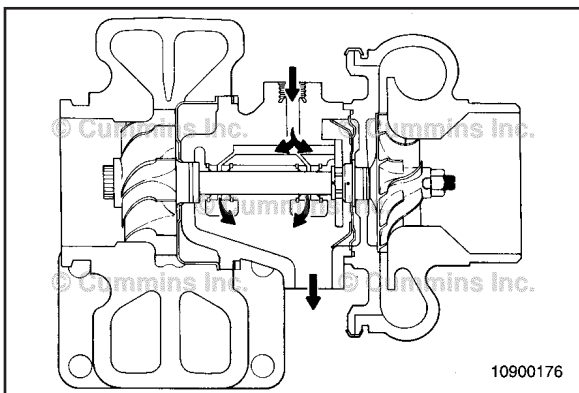

CAUTION

A restricted oil drain line can cause the turbocharger bearing housing to be pressurized, causing oil to leak past the seal rings.

NOTE: An adequate supply of good filtered oil is very important to the life of the turbocharger. Make sure that a high-quality oil is used and that it and the oil filter are changed according to maintenance recommendations. See the corresponding Operation and Maintenance, or Owner's Manual for the engine being serviced.

⚠ CAUTION ⚠

The turbocharger is a performance part and must not be tampered with. The wastegate bracket is an integral part of the turbocharger. Tampering with the wastegate components can reduce durability by increasing cylinder pressure and thermal loading due to incorrect inlet and exhaust manifold pressure. Poor fuel economy and failure to meet regulatory emission laws can result. Increasing the turbocharger boost will not increase engine power.

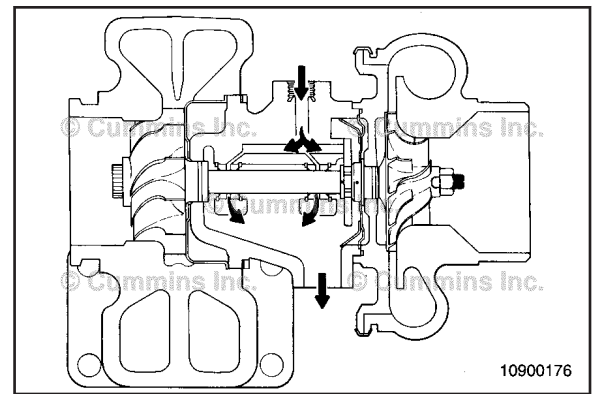

Wastegate turbochargers are used to optimize performance.

NOTE: The wastegate design allows maximum boost to be developed quickly while making sure that the turbocharger does **not** overspeed at higher engine rpm.

Wastegate operation is controlled by an actuator that senses compressor pressure and balances it against a preset spring-load. The wastegate valve is located in the turbine inlet passage. When open, it diverts a portion of the exhaust gas away from the turbine wheel, thereby controlling the shaft speed and boost.

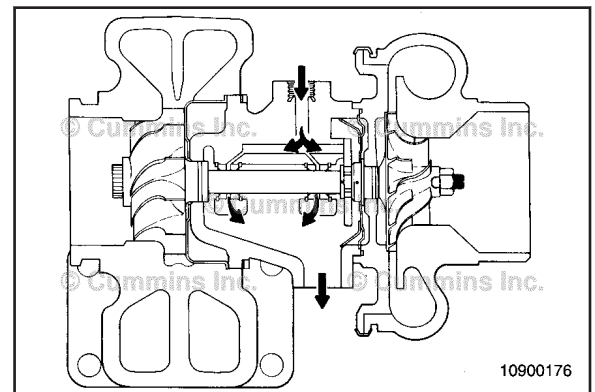

Malfunctioning Turbocharger

⚠ WARNING ⚠

When using solvents, acids, or alkaline materials for cleaning, follow the manufacturer's recommendations for use. Wear goggles and protective clothing to reduce the possibility of personal injury.

Failure of the internal components of the turbocharger can reduce its effectiveness and also cause excessive smoke and low power. A bearing failure can produce friction, which will slow the speed of the rotor assembly. Failed bearings can also allow the blades of the rotor assembly to rub the housings, reducing the rotor assembly speed.

To inspect for the blade rubbing against the housing, clean the area between the housing and the blades with a cotton-tip swab treated with cleaning solvent. This will remove any dirt that has accumulated on the housing due to the close proximity of the blade path and provide a clean surface for inspection.

Turbocharger wastegate failure or miscalibration of the turbocharger wastegate can result in excessively high- or low-boost pressures. Low-boost pressures can cause excessive smoke and low power. High-boost pressures can cause major engine damage.

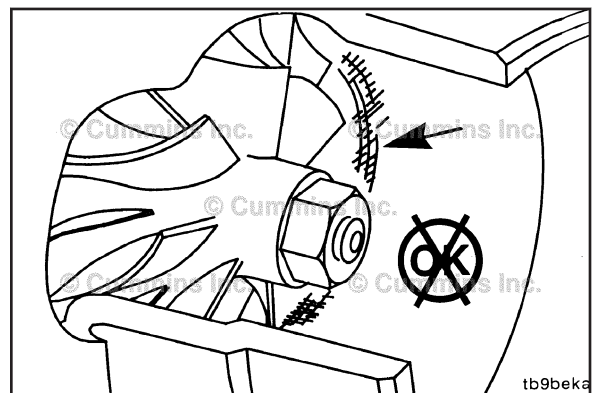

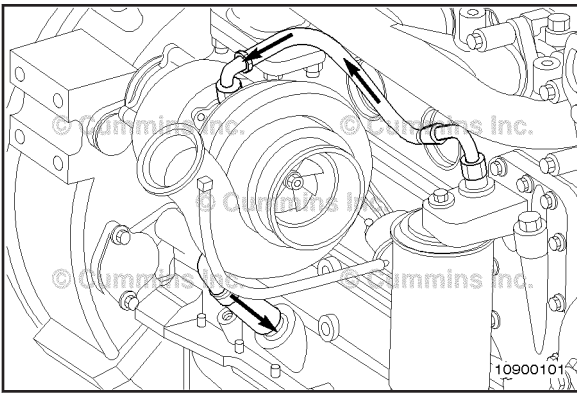

Lubricating Oil Consumption and Leaks

Engine lubricating oil is used to lubricate the bearings and provide some cooling for the turbocharger. The lubricating oil supplied to the turbocharger through the supply line is at engine operating pressure. A return line connected to the bottom of the turbocharger routes the lubricating oil back to the engine lubricating oil pan.

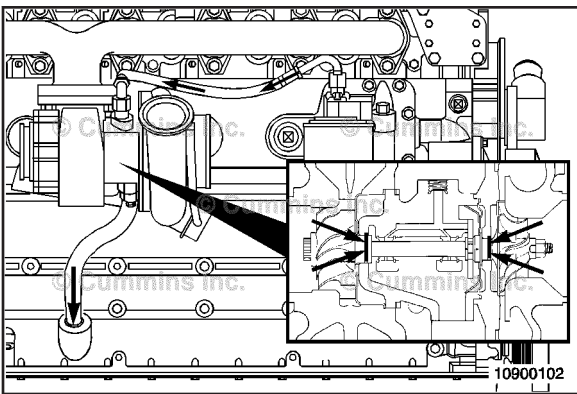

Seal rings are used on each end of the rotor assembly. The primary function of the seals is to prevent exhaust gases and compressed air from entering the turbocharger housing. Lubricating oil leakage from the seals is rare, but it can occur.

NOTE: Excessive crankcase pressure will **not** allow the oil to drain from the turbocharger. This will load the bearing housing and allow lubricating oil to leak past the seal rings and into the engine and exhaust.

If turbine seal leakage into the exhaust occurs on engines with a catalyst, check the exhaust restriction during the repair.

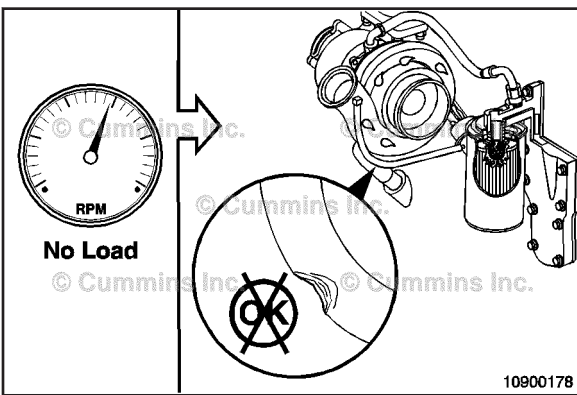

A restricted or damaged lubricating oil return line will cause the turbocharger housing to be pressurized, causing lubricating oil to migrate past the seal rings on both intake and exhaust sides of the turbocharger.

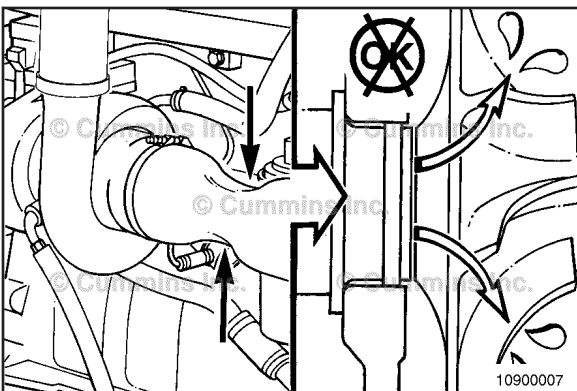

Additionally, high intake or exhaust restrictions can cause a vacuum between the compressor and the turbocharger housing, resulting in lubricating oil leaking past the seal rings at the compressor (intake) side.

NOTE: If this occurs, it is necessary to flush the charge air cooler to clean oil from the intake system. Refer to Procedure 010-027 and Refer to Procedure 010-023

Turbocharger Noise

It is normal for the turbocharger to emit a "whining" sound that varies in intensity depending on engine speed and load. The sound is caused by the very high rotational speed of the rotor assembly and the method used to balance the rotor assembly during manufacturing. Consequently, the sound will be louder at full speed.

NOTE: If possible, operate the engine at full speed to verify the noise level.

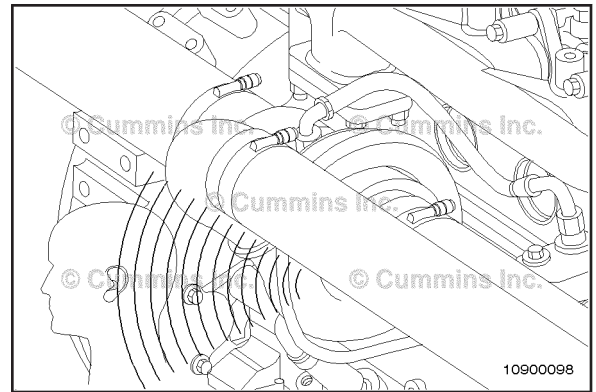

Leaks in the air system intake and/or exhaust components can produce excessive engine noise. A leaking noise usually sounds like high-pitched whining or sucking.

Check for leaks in the intake and exhaust system. Check to make sure all hose clamps are tight. Refer to Procedure 010-024

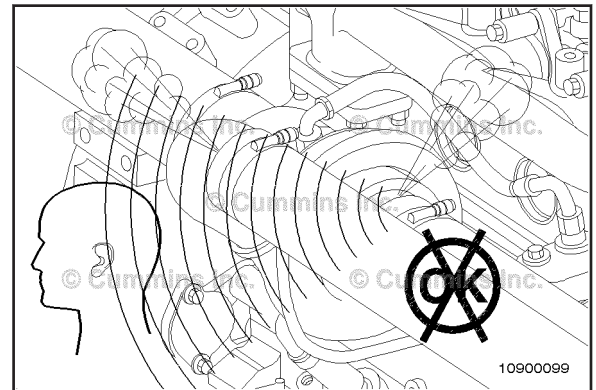

Lower pitched sounds or rattles, at slower engine speeds, can indicate that debris is in the system or that the rotor assembly is touching the housings.

Remove the turbocharger inlet and check for foreign objects.

If suspect, check for turbocharger blade damage and bearing clearance. Refer to Procedure 010-033

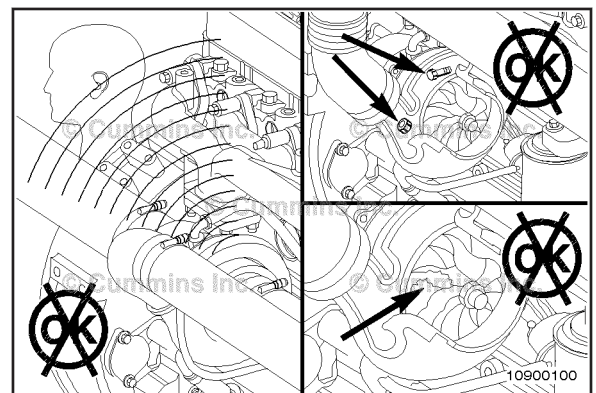

If leaks, blade damage, or improper clearances are found, replace the turbocharger. Refer to Procedure 010-033

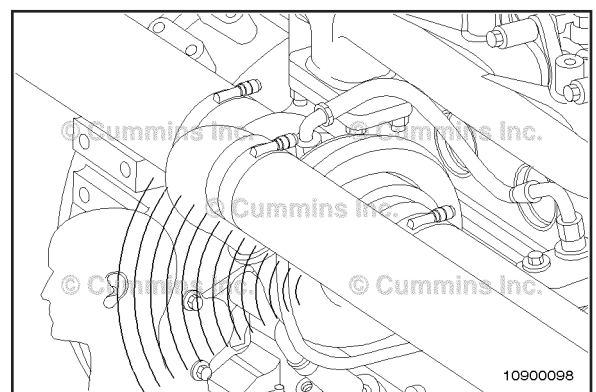

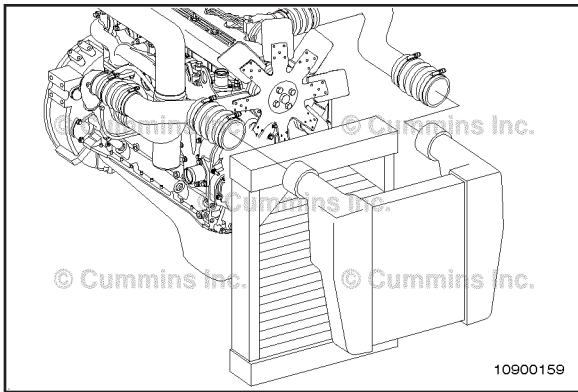

Most engines use a chassis-mounted charge air cooler to improve engine performance and reduce emissions. This system also uses large diameter piping to transfer the air from the engine turbocharger to the charge air cooler, and then returns the air from the charge air cooler to the engine intake manifold.

NOTE: The long-term integrity of the charge air cooling system is the responsibility of the vehicle and component manufacturers.

Flow Diagram, Air Intake System (200-004)

General Information

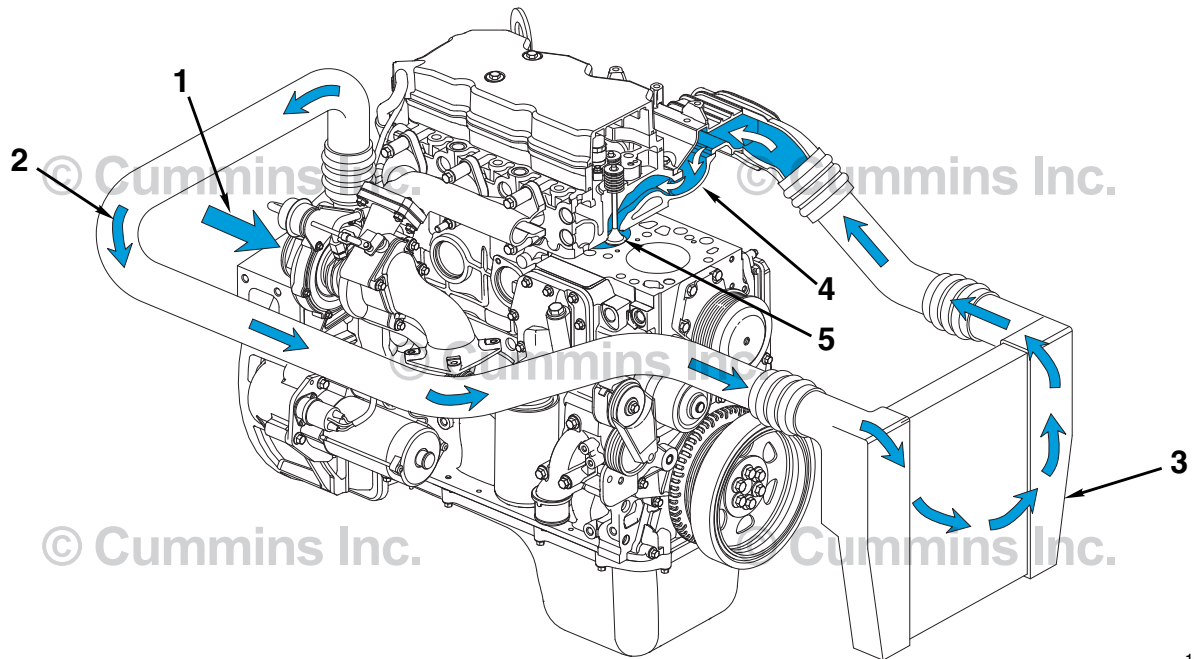

10d00022

- 1 Intake air inlet to turbocharger
- 2 Turbocharger air to charge air cooler
- 3 Charge air cooler
- 4 Intake manifold (integral part of the cylinder head)
- 5 Intake valve.

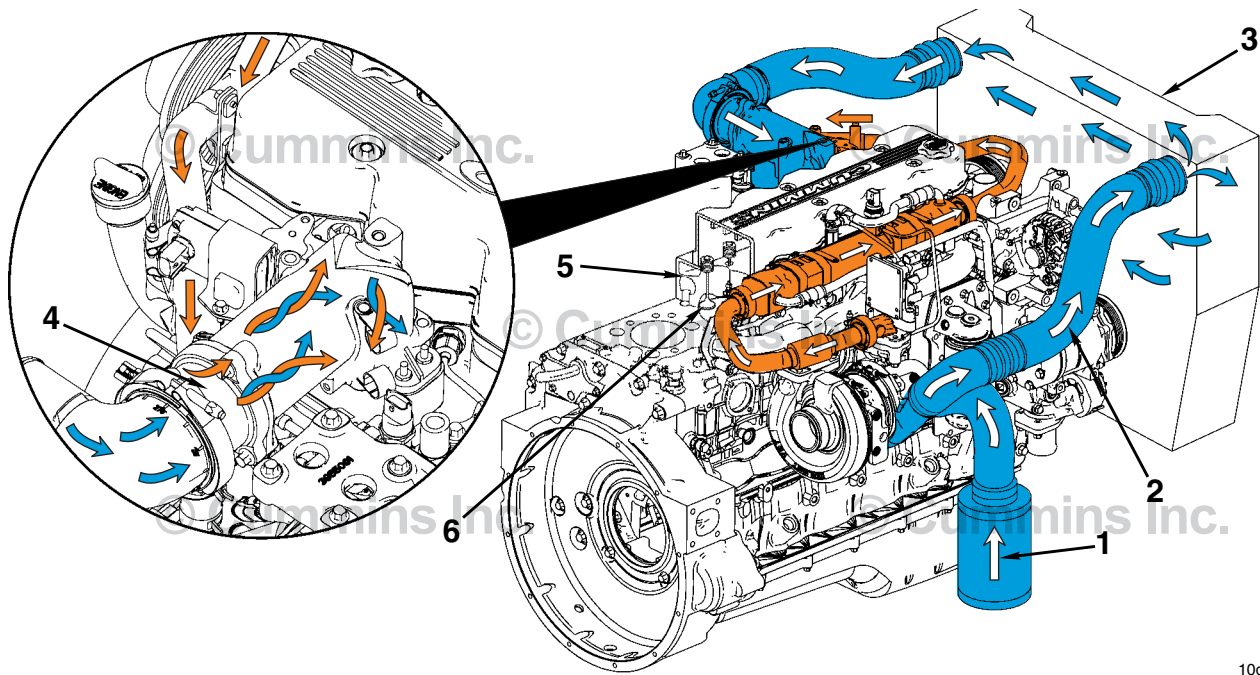

10d00089

- 1 Intake air inlet to turbocharger
- 2 Turbocharger air to charge air cooler
- 3 Charge air cooler
- 4 EGR mixer
- 5 Intake manifold (integral part of the cylinder head)
- 6 Intake valve.

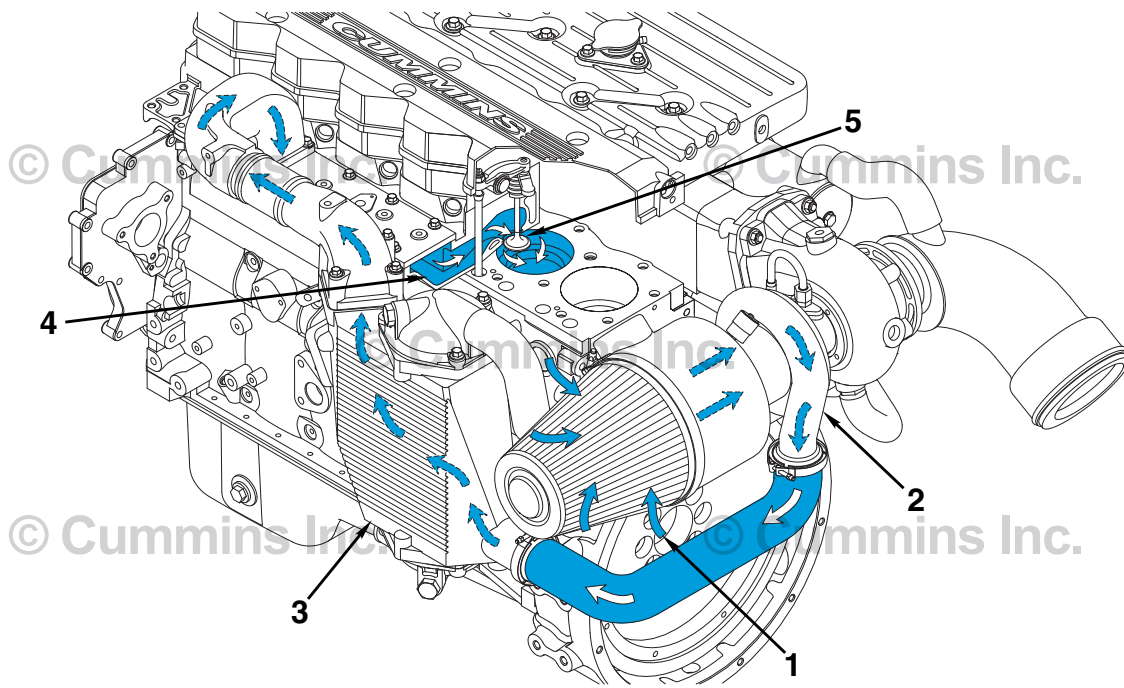

- 1 Intake air inlet
- 2 Turbocharger
- 3 Aftercooler
- 4 Intake manifold
- 5 Intake valve

10d00197

Flow Diagram, Exhaust System (200-005)

General Information

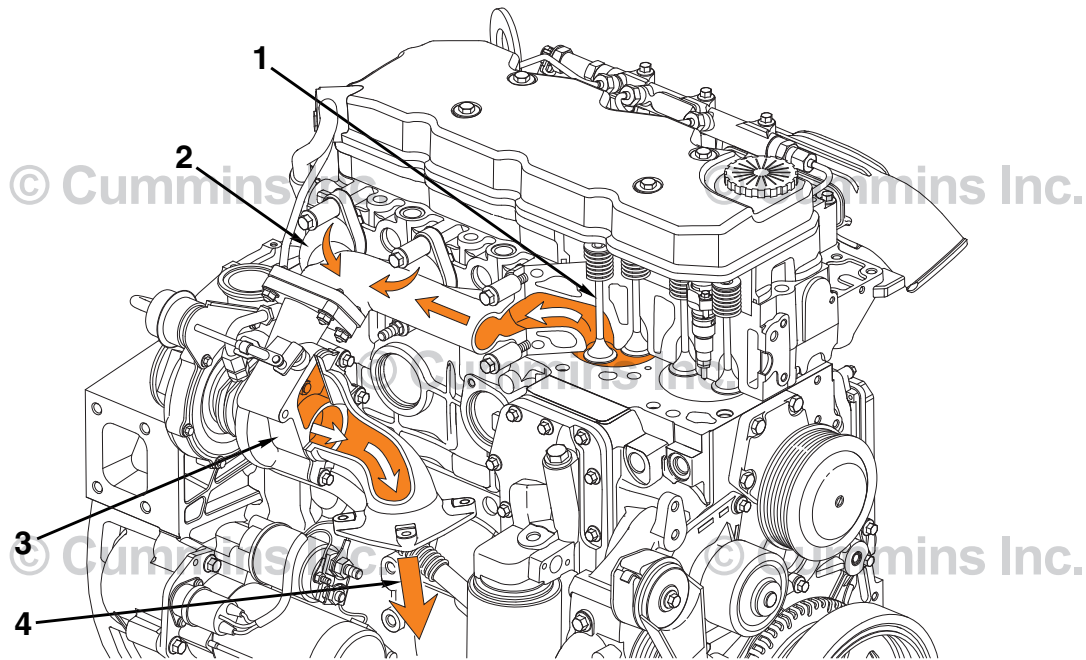

- 1 Exhaust valve
- 2 Exhaust manifold
- 3 Turbocharger
- 4 Turbocharger exhaust outlet.

11d00018

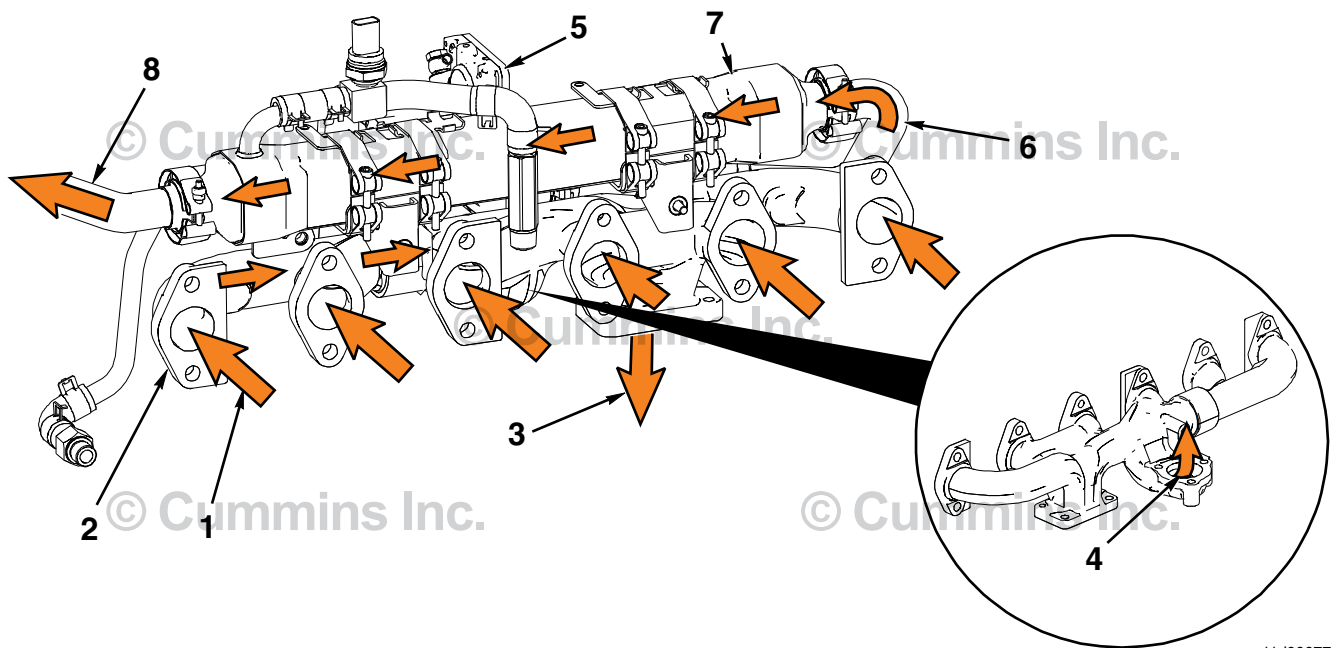

11d00077

- 1 Exhaust gas to manifold
- 2 Exhaust manifold
- 3 Exhaust gas to turbocharger
- 4 Exhaust gas to EGR valve
- 5 EGR valve
- 6 Exhaust gas from EGR valve to EGR cooler connection
- 7 EGR cooler
- 8 Cooled exhaust gas to EGR connection tube and EGR mixer.

Compressed Air System - Overview (012-999)

General Information

The compressed air system normally consists of a gear-driven air compressor, an air governor, air tanks, and all necessary plumbing.

The compressor operates continuously but has a "loaded" and "unloaded" operating mode. The operating mode is controlled by a pressure activated governor and the compressor unloader assembly. When the air system reaches a predetermined pressure, the governor applies an air signal to the unloader assembly, causing the unloader to either hold open or shutoff the compressor's intake valve, which causes compressed air to stop flowing into the air system. As the system is used, the pressure drops. At a predetermined pressure, the governor exhausts the air signal to the compressor unloader assembly, allowing the compressor to again pump compressed air into the system.

Air compressors are available in an air cooled or water cooled version. The **only** significant difference is that changes have been made to the cylinder head to incorporate a water passage.

Air compressors are also available in turbocharged and naturally aspirated versions. A turbocharged air compressor receives intake air from the intake of the engine. This means the intake air is at the same pressure as the intake of the engine. A naturally aspirated air compressor receives intake air from either the inlet side of the turbocharger or a separate air intake source than the engine. The intake air would be approximately equal ambient air pressure.

Various brands of compressors can be used on the ISB and QSB (4 and 6 cylinder) engines. Troubleshooting procedures are very similar for these air compressors but refer to the compressor manufacturer's manual for information including detailed repair information and torque values.

Most air compressor cylinder heads can be serviced without removing the compressor from the engine. This manual will cover servicing of the cylinder head with the compressor installed on the engine. If there is internal damage to the air compressor, the air compressor **must** be replaced.

Most air compressors are timed to the engine to reduce vibrations. When removing and installing the air compressor, make sure to reference the air compressor timing Refer to Procedure Procedure 012-014

Flow Diagram, Compressed Air System (200-006)

Flow Diagram

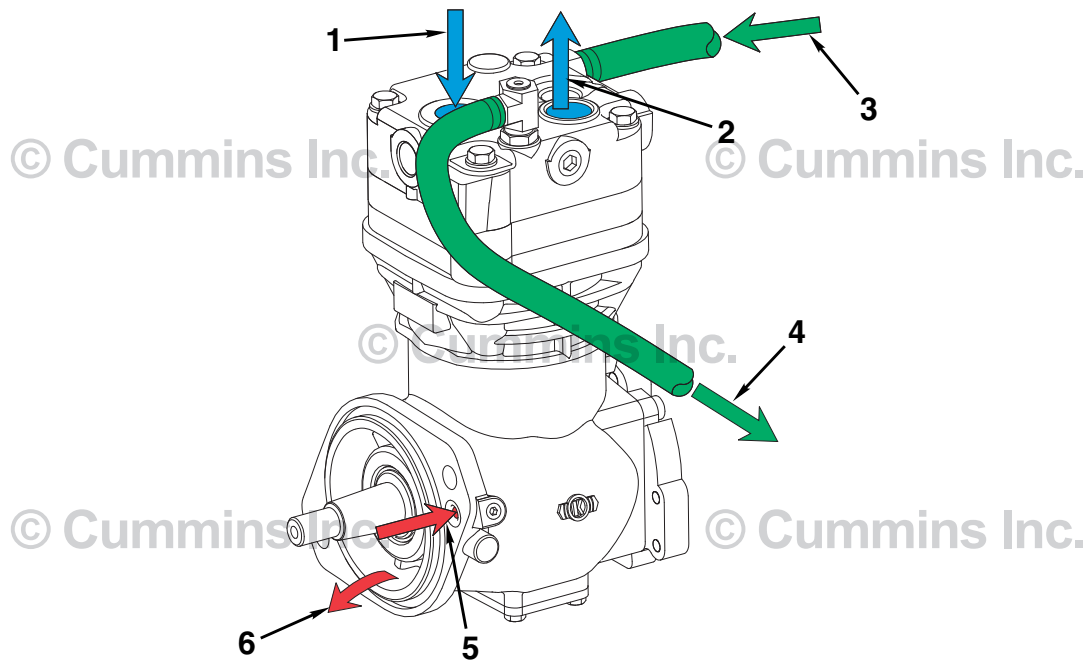

12d00045

- 1 Air in
- 2 Air out
- 3 Coolant in
- 4 Coolant out
- 5 Lubricating oil in (internal to the gear housing)
- 6 Lubricating oil out (internal to the gear housing).

Electrical Equipment - Overview (013-999)

General Information

⚠ WARNING ⚠

Batteries can emit explosive gases. To reduce the possibility of severe personal injury, always ventilate the compartment before beginning work. Always detach the negative (-) battery cable first, and attach the negative(-) battery cable last.

⚠ WARNING ⚠

To reduce the possibility of personal injury, keep hands, long hair, jewelry, and loose-fitting or torn clothing away from fans and other moving parts.

The basic electrical system consists of:

- Batteries (1)
- A starter motor (2)
- An alternator (3)
- A magnetic switch (4)
- A keyswitch (5)
- All necessary wiring.

All components **must** be carefully matched.

The accompanying illustrations show typical parallel and series battery connections:

- Parallel connection
- Series connection.

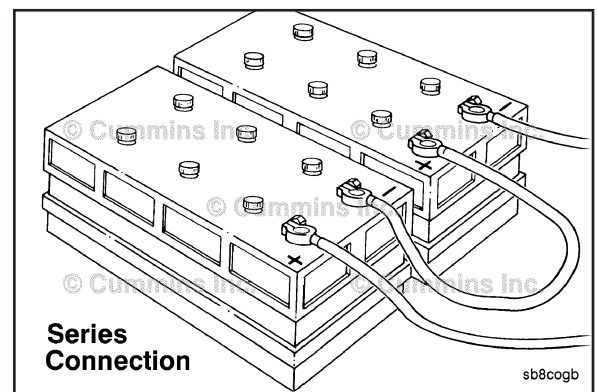
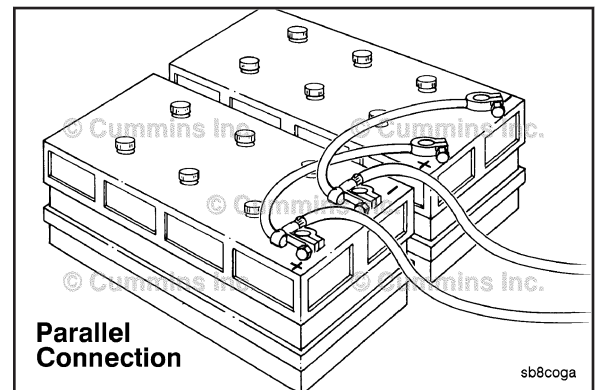
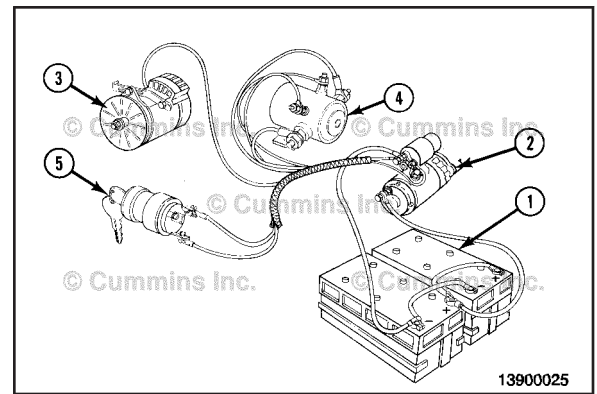

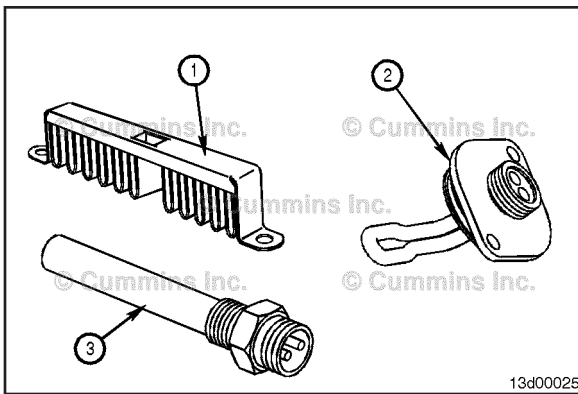

Other electrical accessories available are:

- Intake heater (1).
- Engine coolant heater (2)
- Oil pan heater (3)

Engine Testing - Overview (014-999)

General Information

The engine test is a combination of an engine run-in and a performance check. The engine run-in procedure provides an operating period that allows the engine parts to achieve a final finish and fit. The performance check provides an opportunity to perform final adjustments needed to optimize the engine's performance.

An engine test can be performed using either an engine dynamometer or a chassis dynamometer. If a dynamometer is **not** available, an engine test **must** be performed in a manner that simulates a dynamometer test.

Check the dynamometer before beginning the test. The dynamometer **must** have the capability to test the performance of the engine when the engine is operating at the maximum rpm and horsepower range (full power).

The engine crankcase pressure, often referred to as engine blowby, is an important factor that indicates when the piston rings have achieved the correct finish and fit. Rapid changes of blowby or values that exceed specifications more than 50 percent indicate that something is wrong. The engine test **must** be discontinued until the cause has been determined and corrected.

Section TS - Troubleshooting Symptoms

Section Contents

	Page
Troubleshooting Procedures and Techniques	TS-1
General Information.....	TS-1
Troubleshooting Symptoms Charts	TS-2
General Information.....	TS-2
Air Compressor Air Pressure Rises Slowly	TS-14
Air Compressor Cycles Frequently.....	TS-15
Air Compressor Noise is Excessive.....	TS-16
Air Compressor Pumping Excess Lubricating Oil into the Air System	TS-17
Air Compressor Will Not Maintain Adequate Air Pressure (Not Pumping Continuously).....	TS-19
Air Compressor Will Not Pump Air.....	TS-20
Air Compressor Will Not Stop Pumping.....	TS-22
Alternator Not Charging or Insufficient Charging.....	TS-23
Alternator Overcharging.....	TS-25
Coolant in the Lubricating Oil.....	TS-38
Coolant Loss - External.....	TS-26
Coolant Loss - Internal.....	TS-28
Coolant Temperature Above Normal - Gradual Overheat.....	TS-29
Coolant Temperature Above Normal - Sea Water Cooling System.....	TS-39
Coolant Temperature Above Normal - Sudden Overheat.....	TS-33
Coolant Temperature Below Normal.....	TS-36
Crankcase Gases (Blowby) Excessive.....	TS-40
Cranking Fuel Pressure is Low.....	TS-42
Diesel Exhaust Fluid Usage - Abnormal.....	TS-92
Engine Cranks Slowly — (Electric Starter).....	TS-60
Engine Decelerates Slowly.....	TS-43
Engine Noise Excessive.....	TS-44
Engine Noise Excessive — Combustion Knocks.....	TS-47
Engine Noise Excessive — Connecting Rod.....	TS-48
Engine Noise Excessive - Drive Belt.....	TS-93
Engine Noise Excessive — Main Bearing.....	TS-50
Engine Noise Excessive — Piston.....	TS-51
Engine Noise Excessive - Turbocharger.....	TS-52
Engine Speed Surges in PTO or Cruise Control.....	TS-53
Engine Will Not Crank — (Electric Starter).....	TS-58
Engine Will Not Crank or Cranks Slowly (Air Starter).....	TS-62
Engine Will Not Shut Off.....	TS-64
Fuel Consumption Excessive.....	TS-65
Fuel in Coolant.....	TS-69
Fuel in the Lubricating Oil.....	TS-70
Intake Manifold Air Temperature Above Specification.....	TS-72
Intake Manifold Pressure (Boost) is Below Normal.....	TS-75
Lubricating Oil Consumption Excessive.....	TS-77
Lubricating Oil Contaminated.....	TS-80
Lubricating Oil Pressure High.....	TS-81
Lubricating Oil Pressure Low.....	TS-83
Lubricating Oil Sludge in the Crankcase Excessive.....	TS-86
Lubricating Oil Temperature Above Specification.....	TS-88
Lubricating or Transmission Oil in the Coolant.....	TS-89
Turbocharger Leaks Engine Oil or Fuel.....	TS-90
Troubleshooting Overview	TS-3
Connecting Rod Bearing Noise.....	TS-3
Driveability - General Information.....	TS-3
Driveability/Low Power - Customer Complaint Form.....	TS-5
Driveability/Low Power/Excessive Fuel Consumption - Checklist.....	TS-8
Engine Noise Diagnostic Procedures - General Information.....	TS-3
Fuel Consumption - Customer Complaint Form.....	TS-10
Fuel Consumption - General Information.....	TS-9

Main Bearing Noise.....TS-3
Oil Consumption.....TS-11
Piston Noise.....TS-3

Troubleshooting Procedures and Techniques

General Information

A thorough analysis of the customer's complaint is the key to successful troubleshooting. The more information known about a complaint, the faster and easier the problem can be solved.

The Troubleshooting Symptom Charts are organized so that a problem can be located and corrected by doing the easiest and most logical things first. Complete all steps in the sequence shown from top to bottom.

It is **not** possible to include all the solutions to problems that can occur; however, these charts are designed to stimulate a thought process that will lead to the cause and correction of the problem.

Follow these basic troubleshooting steps:

- Get all the facts concerning the complaint
- Analyze the problem thoroughly
- Relate the symptoms to the basic engine systems and components
- Consider any recent maintenance or repair action that can relate to the complaint
- Double-check before beginning any disassembly
- Solve the problem by using the symptom charts and doing the easiest things first
- Determine the cause of the problem and make a thorough repair
- After repairs have been made, operate the engine to make sure the cause of the complaint has been corrected

Troubleshooting Symptoms Charts

General Information

Use the charts on the following pages of this section to aid in diagnosing specific symptoms. Read each row of blocks from top to bottom. Follow through the chart to identify the corrective action.



Troubleshooting presents the risk of equipment damage, personal injury or death. Troubleshooting must be performed by trained, experienced technicians.

Troubleshooting Overview

Engine Noise Diagnostic Procedures - General Information

NOTE: When diagnosing engine noise problems, make sure that noises caused by accessories, such as the air compressor and power take-off, are **not** mistaken for engine noises. Remove the accessory drive belts to eliminate noise caused by these units. Noise will also travel to other metal parts **not** related to the problem. The use of a stethoscope can help locate an engine noise.

Engine noises heard at the crankshaft speed, engine rpm, are noises related to the crankshaft, rods, pistons, and piston pins. Noises heard at the camshaft speed, one-half of the engine rpm, are related to the valve train. A handheld digital tachometer can help determine if the noise is related to components operating at the crankshaft or camshaft speed.

Engine noise can sometimes be isolated by performing a cylinder cutout test. See Procedure 014-008 in the corresponding Troubleshooting and Repair Manual or Service manual for the engine being worked on. If the volume of the noise decreases or the noise disappears, it is related to that particular engine cylinder.

There is **not** a definite rule or test that will positively determine the source of a noise complaint.

Engine-driven components and accessories, such as gear-driven fan clutches, hydraulic pumps, belt-driven alternators, air-conditioning compressors, and turbochargers, can contribute to engine noise. Use the following information as a guide to diagnosing engine noise.

Main Bearing Noise

(Refer to Engine Noise Excessive - Main Bearing symptom tree)

The noise caused by a loose main bearing is a loud dull knock heard when the engine is pulling a load. If all main bearings are loose, a loud clatter will be heard. The knock is heard regularly every other revolution. The noise is the loudest when the engine is lugging or under heavy load. The knock is duller than a connecting rod noise. Low oil pressure can also accompany this condition.

If the bearing is **not** loose enough to produce a knock by itself, the bearing can knock if the oil is too thin, or if there is no oil at the bearing.

An irregular noise can indicate worn crankshaft thrust bearings.

An intermittent sharp knock indicates excessive crankshaft end clearance. Repeated clutch disengagements can cause a change in the noise.

Connecting Rod Bearing Noise

(Refer to Engine Noise Excessive - Connecting Rod symptom tree)

Connecting rods with excessive clearance knock at all engine speeds, and under both idle and load conditions. When the bearings begin to become loose, the noise can be confused with piston slap or loose piston pins. The noise increases in volume with engine speed. Low oil pressure can also accompany this condition.

Piston Noise

(Refer to Engine Noise Excessive - Piston symptom tree)

It is difficult to tell the difference between piston pin, connecting rod, and piston noise. A loose piston pin causes a loud double knock which is usually heard when the engine is idling. When the injector to this cylinder is cut out, a noticeable change will be heard in the sound of the knocking noise. However, on some engines the knock becomes more noticeable when the vehicle is operated on the road at steady speed condition.

Driveability - General Information

Driveability is a term that in general describes vehicle performance on the road. Driveability problems for an engine can be caused by several different factors. Some of the factors are engine-related and some are **not**.

Before troubleshooting, it is important to determine the exact complaint and whether the engine has a real driveability issue or if it simply does **not** meet driver expectations. The Driveability/Low-Power Customer Complaint Form is a valuable list of questions that **must** be used to assist the service technician in determining what type of driveability issue the vehicle is experiencing. Complete the checklist before troubleshooting the issue. The form can be found at the end of this section. If an engine is performing to factory specifications but does **not** meet the customer's expectations, explain to the customer that nothing is wrong with the vehicle and why.

Low power is a term that is used in the field to describe many different performance issues. However, in this manual low power is defined as the inability of the engine to produce the power necessary to move the vehicle at a speed that

can be reasonably expected under the given conditions of load, grade, wind, and so on. Low power is usually caused by the lack of fuel flow that can be caused by any of the following factors:

- Lack of full travel of the accelerator pedal
- Failed boost sensor, if equipped
- Excessive fuel inlet, intake, exhaust, or drainline restriction
- Loose fuel pump suction lines.

Low power is the inability of the vehicle to accelerate satisfactorily from a stop or the bottom of a grade. Refer to the symptom tree Engine Power Output Low for the proper procedures to locate and correct a low-power issue. The chart starts off with basic items that can cause lower power.

Poor acceleration or response is described in this manual as the inability of the vehicle to accelerate satisfactorily from a stop or from the bottom of a grade. It can also be the lag in acceleration during an attempt to pass or overtake another vehicle at conditions less than rated speed and load. Poor acceleration or response is difficult to troubleshoot since it can be caused by factors such as:

- Engine- or pump-related factors
- Driver technique
- Improper gear shifting
- Improper engine application
- Worn clutch or clutch linkage.

Engine-related poor acceleration or response can be caused by several different factors such as:

- Failed boost sensor, if equipped
- Excessive drainline restriction
- Accelerator deadband.

Driveability/Low Power - Customer Complaint Form

Customer _____ Name/Company _____ Date _____

- Describe Problem/Complaint _____
- Symptoms of the Problem/Complaint
- When cranking:
 - ___ Cranks too slowly
 - ___ Cranks OK but does not start easily
 - ___ Cranks OK but does not start
 - ___ Slow start; _____ seconds
 - ___ Starts then dies
 - ___ Idle RPM is rough when engine is cold
 - ___ Idle RPM is rough when engine is hot
- When driving
 - ___ Misses or hesitates during acceleration
 - ___ Misses or hesitates during deceleration
 - ___ Stalls (dies) during acceleration
 - ___ Stalls (dies) during deceleration
 - ___ Smokes: ___ black ___ white
 - ___ Low power
 - ___ Unusual engine behavior
- When do you notice the Problem/Complaint occurring?
- Engine conditions:
 - When the coolant temperature for the engine is:
 - ___ cold ___ normal ___ hot ___ all temperatures
 - When the engine is ___ RPM on the tachometer
- Weather conditions:
 - ___ cold (below 10°C [50°F]) ___ hot (above 27°C [80°F]) ___ humid or rainy ___ other _____
- When driving:
 - ___ Accelerating
 - ___ Decelerating
 - ___ Climbing a grade / hill
 - ___ Down hill
 - ___ Braking
 - ___ Unloaded
 - ___ Loaded
- How did the problem occur? Suddenly _____ Gradually _____
- At what hour/mileage did the problem begin? Hours _____ Miles _____ Since New _____
- After engine repair? Yes _____ No _____
- After equipment repair? Yes _____ No _____
- After change in equipment use? Yes _____ No _____
- After change in selected programmable parameters? Yes _____ No _____
- If so, what was repaired and when? _____
- Does the vehicle also experience poor fuel economy? Yes _____ No _____

This Page Left Intentionally Blank

Driveability/Low Power - Customer Complaint Form

Answer the following questions using selections (A through F) listed below. Circle the letter or letters that best describe the complaint.

A - Compared to fleet, B - compared to competition, C - compared to previous engine

D - Personal expectation, E - will **not** pull on hill, F - will **not** pull on flat terrain

• **A B C D E F**

• Can the vehicle obtain the expected road speed? Yes _____ No _____

• What is desired speed? rpm/mpg _____

• What is achieved speed? rpm/mpg _____

• Gross vehicle weight _____

• **A B C D E F**

• Has the vehicle's load changed? Yes _____ No _____

• Is the vehicle able to pull the load? Yes _____ No _____

• When?

• _____ On hilly terrain

• _____ With a loaded trailer

• _____ On flat terrain

• _____

Other

IF THE ANSWER WAS NO TO ONE OF THE PREVIOUS QUESTIONS, FILL OUT THE DRIVEABILITY/LOW-POWER/EXCESSIVE FUEL CONSUMPTION CHECKLIST AND GO TO THE LOW-POWER SYMPTOM TREE.

A B C D E F

• Is the vehicle slow to accelerate or respond? Yes _____ No _____

When?

• From a stop? Yes _____ No _____

• After a shift? Yes _____ No _____ rpm _____

• Before a shift? Yes _____ No _____ rpm _____

• No shift? Yes _____ No _____ rpm _____

• **A B C D E F**

• Does the vehicle hesitate after periods of long deceleration or coasting? Yes _____ No _____ rpm _____

IF THE ANSWER WAS YES TO ONE OF THE PREVIOUS QUESTIONS, FILL OUT THE DRIVEABILITY/LOW-POWER/EXCESSIVE FUEL CONSUMPTION CHECKLIST, AND GO TO THE POOR ACCELERATION/RESPONSE SYMPTOM TREE.

Additional Comments:

- _____

These Pages Can Be Copied for Your Convenience.

Driveability/Low Power/Excessive Fuel Consumption - Checklist

Vehicle/Equipment Specifications

Year, _____ Type, _____ and _____ Model: _____

Transmission (RT 14609, and so forth): _____,

Duty Cycle: _____,

Rear Axle Ratio, No. of Axles: _____, Application: Industrial _____, Marine _____, Genset _____, Automotive _____

Typical Gross Vehicle Weight: _____, Engine Rating: _____

Trailer Type and Size: _____, Height: _____, Weight: _____

Tire Size (11R x 24.5, low profile, and so forth) _____

Tire Type: Radial _____, Standard Tread _____, Extra Tread _____

Fan Type: Direct Drive _____, Viscous _____, Clutch _____

Power Steering: Yes _____ No _____ Air Conditioner: Yes _____ No _____ Air Shield: Yes _____

No _____ Freon Compressor: Yes _____ No _____

General Information					
DO Number:		SC Number:			
Fuel Pump Code:		Fuel Pump Serial Number:			
Mileage:		Engine Serial Number.:			
Date in Service:		Engine Model and Rating:			
Cruise Speed and rpm:		Rated Speed and rpm:			
Road Speed Governor:		Yes	No	Type:	
Engine Brake:		Yes	No	Type/Brand:	
Chassis and Other Related Items					
Tank Vents:	OK	Not OK	Obvious Fuel Leaks:	Yes	No
Brake Drag:	OK	Not OK	Axle Alignment:	OK	Not OK
Altitude:		Ambient Temperature:			
Fuel Heater:		Conditions (Wind, Rain, Snow):			
Fuel Type:		Number 1D	Number 2D	Other	
Typical Terrain:		Flat	Hilly	Percent Asphalt	Percent Concrete

Additional Comments:

NOTE: Use this information for VE/VMS® run.

This Page Can Be Copied for Your Convenience

Fuel Consumption - General Information

The cause of excessive fuel consumption is hard to diagnose and correct because of the potential number of factors involved. Actual fuel consumption problems can be caused by any of the following factors:

- Engine factors
- Vehicle factors and specifications
- Environmental factors
- Driver technique and operating practices
- Fuel system factors
- Low-power/driveability problems.

Before troubleshooting, it is important to determine the exact complaint. Is the complaint based on whether the problem is real or perceived, or does **not** meet driver expectations? The Fuel Consumption - Customer Complaint Form (on the next page) is a valuable list of questions that can be used to assist the service technician in determining the cause of the problem. Complete the form before troubleshooting the complaint. The following are some of the factors that **must** be considered when troubleshooting fuel consumption complaints.

- 1 **Result of a Low-Power/Driveability Problem:** An operator will change driving style to compensate for a low power/driveability problem. Some things the driver is likely to do are (a) shift to a higher engine rpm or (b) run on the droop curve in a lower gear instead of upshifting to drive at partial-throttle conditions. These changes in driving style will increase the amount of fuel used.
- 2 **Driver Technique and Operating Practices:** As a general rule, a 1-mph increase in road speed equals a 0.1 mpg increase in fuel consumption. For example, increasing road speed from 50 to 60 mph will result in a loss of fuel mileage of 1 mpg.
- 3 **Environmental and Seasonal Weather Changes:** As a general rule, there can be as much as a 1- to 1.5-mpg difference in fuel consumption depending on the season and the weather conditions.
- 4 **Excessive Idling Time:** Idling the engine can use from 0.5 to 1.5 gallons per hour depending on the engine idle speed.
- 5 **Truck Route and Terrain:** East/west routes experience almost continuous crosswinds and head winds. Less fuel can be used on north/south routes where parts of the trip are **not only** warmer, but also have less wind resistance.
- 6 **Vehicle Aerodynamics:** The largest single power requirement for a truck is the power needed to overcome air resistance. As a general rule, each 10-percent reduction in air resistance results in a 5-percent increase in mpg.
- 7 **Rolling Resistance:** Rolling resistance is the second largest consumer of power on a truck. The type of tire and tread design has a sizable effect on fuel economy and performance. Changing from a bias ply to low-profile radial tire can reduce rolling resistance by about 36 percent.
- 8 **Additional Devices Using the Same Fuel Source:** Additional devices may use the same fuel tank as the vehicle. For example, excessive use of generators or reefers can falsely indicate high fuel consumption.

Additional vehicle factors, vehicle specifications, and axle alignment can also affect fuel consumption. For additional information on troubleshooting fuel consumption complaints, see Troubleshooting Excessive Fuel Consumption, Bulletin 3387245.

Fuel Consumption - Customer Complaint Form

Customer _____ Name/Company _____ Date _____

Answer the following questions. Some questions require making an X next to the appropriate answer.

- 1 What fuel mileage is expected? _____ Expected mpg
- 2 What are the expectations based on? Original mileage _____, Other units in fleet _____, Competitive engines _____ Previous engine owned _____, Expectations **only** _____, VE/VMS® report _____
- 3 When did the problem occur? Since New _____, Suddenly _____, Gradually _____
- 4 Did the problem start after a repair? Yes _____ No _____ If so, what was repaired and when?

- 5 Is the vehicle also experiencing a driveability issue (low power or poor acceleration/response)? Yes _____ No _____

IF ANSWERED YES, FILL OUT THE DRIVEABILITY/LOW-POWER/EXCESSIVE FUEL CONSUMPTION CHECKLIST, AND GO TO THE ENGINE POWER OUTPUT LOW TROUBLESHOOTING SYMPTOM CHART.

- 1 Is the problem seasonal? Yes _____ No _____
- 2 Weather conditions during fuel consumption check? Rain _____, Snow _____, Wind _____, Hot temperatures _____, Cold temperatures _____
- 3 How is the fuel mileage measured? Tank _____, Trip _____, Month _____, Year _____ Hubometer _____, Odometer _____
- 4 Are accurate records kept of fuel added on the road? Yes _____ No _____
- 5 Do routes vary between compared vehicles? Yes _____ No _____
- 6 Have routes changed for the engine being checked? Yes _____ No _____
- 7 What are the loads hauled, compared to comparison unit? Gross Vehicle Weight _____ Heavier _____, Lighter _____
- 8 What is the altitude during operation? Below 10,000 feet _____, Above 10,000 feet _____
- 9 How much of the time is the truck spent idling? Hours/day _____
- 10 Is the driver technique or operating practices affecting fuel economy?
 - High road speed: mph _____
 - Operate at rated speed or above: rpm _____
 - Incorrect shift rpm: Shift rpm _____, Torque peak _____
 - Operate at a cruise speed: rpm _____
 - Compensating for low power: Yes _____ No _____

IF, AFTER FILLING OUT THIS FORM, IT APPEARS THAT THE ISSUE IS NOT CAUSED BY VEHICLE FACTORS, ENVIRONMENTAL FACTORS, OR DRIVER TECHNIQUE, FILL OUT THE DRIVEABILITY/LOW-POWER/EXCESSIVE FUEL CONSUMPTION CHECKLIST, AND GO TO THE FUEL CONSUMPTION EXCESSIVE TROUBLESHOOTING SYMPTOM TREE.

This Page Can Be Copied for Your Convenience.

Oil Consumption

In addition to the information that follows, a service publication is available titled Technical Overview of Oil Consumption, Bulletin 3379214.

Cummins Inc. defines acceptable oil usage as outlined in the following table.

ACCEPTABLE OIL USAGE									
ANY TIME DURING COVERAGE PERIOD									
ENGINE FAMILY	MILES PER QUART	MILES PER LITER	MILES PER IMPERIAL QUART	KM PER QUART	KM PER LITER	KM PER IMPERIAL QUART	HRS PER QT	HRS PER LITER	HOURS PER IMPERIAL QUART
A - Series	-	-	-	-	-	-	10.0	10.6	12.0
B3.3/4B	400	425	475	650	675	775	10.0	10.6	12.0
ISF	400	425	475	650	675	775	10.0	10.6	12.0
6B/ISB/QSB	400	425	475	650	675	775	10.0	10.6	12.0
6C/ISC/QSC/ISL	400	425	475	650	675	775	10.0	10.6	12.0
V/VT-378	-	-	-	-	-	-	4.0	4.3	5.0
V/VT-504	250	265	310	400	425	485	4.0	4.3	4.8
V/VT-555	250	265	310	400	425	485	4.0	4.3	4.8
L10	500	530	620	800	850	970	7.0	7.4	8.4
M11/ISM	500	530	620	800	850	970	7.0	7.4	8.4
N14/NT	500	530	620	800	850	970	7.0	7.4	8.4
ISX/QSX/Signature™	500	530	620	800	850	970	7.0	7.4	8.4
V/VT/VTA-903	250	265	310	400	425	485	4.0	4.3	4.8
KT/KTA19	200	210	250	320	340	390	3.0	3.2	3.6
V/VT/VTA28	-	-	-	-	-	-	2.0	2.1	1.1
KT/KTA38	-	-	-	-	-	-	1.5	1.6	1.8
KTA50	-	-	-	-	-	-	1.1	1.2	1.3
QSK19	-	-	-	-	-	-	3.0	3.2	3.6
QST30	-	-	-	-	-	-	1.7	1.8	2.0
QSK23	-	-	-	-	-	-	1.7	1.8	2.0
QSK38	-	-	-	-	-	-	1.3	1.4	1.5
QSK45	-	-	-	-	-	-	1.25	1.3	1.5
QSK50	-	-	-	-	-	-	1.0	1.1	1.2
QSK60	-	-	-	-	-	-	0.9	0.95	1.1
QSK78	-	-	-	-	-	-	0.6	0.65	0.72

ACCEPTABLE OIL USAGE (Transit Bus, Shuttle Bus, and School Bus)									
ANY TIME DURING COVERAGE PERIOD									
ENGINE FAMILY	HRS PER QT	HRS PER LITER	HOURS PER IMPERIAL QUART	MILES PER QUART	MILES PER LITER	MILES PER IMPERIAL QUART	KM PER QUART	KM PER LITER	KM PER IMPERIAL QUART
B	10.0	10.6	12.0	200	210	240	320	340	385
C	8.0	8.5	10.0	150	160	180	240	255	290
L, M, N	4.0	4.3	5.0	100	105	120	160	170	195

Oil Consumption



Cummins
Engine Company, Inc.
Box 3005
Columbus, IN, U.S.A.
47202-3005

15200020

Engine Lubricating Oil Consumption Report				
Owner's Name	Engine Serial Number		Engine Model and Horsepower	
	Date of Delivery			
	Month	Day	Year	
Address	Equipment Manufacturer			
City	State/Province	Equipment Serial Number	Fuel Pump Serial Number	
Engine Application (describe)	Oil and Filter Change Interval		Complaint Originally Registered	
	Oil	Filters	Date	Miles/Hours/ Kilometers
Lubricating Oil Added				
Date Added Oil	Engine Operation Miles/Hours/ Kilometers	Oil Added Liters/Quarts	Oil Used Brand/ Viscosity	
Start Test				
Last Mileage/Hours/Kilometers _____ Minus Start Mileage/Hours/ Kilometers _____				
Equals Test Mileage/Hours/Kilometers _____ Divided by Oil Added _____				
Equals _____				
Usage Rate _____				
Customer Signature	Cummins® Dealer		Cummins® Distributor	
Cummins Inc. Form 4755				

Oil Consumption



**Cummins
Engine Company, Inc.
Box 3005
Columbus, IN, U.S.A.
47202-3005**

15200020

OIL CONSUMPTION REPORT	
Customer Name:	D/r:
Engine Model:	Mi/Km/Hr:
Engine Serial Number:	CPL Number:
Vehicle Make/Model:	Date:
Signed: _____	

Air Compressor Air Pressure Rises Slowly

This is symptom tree t004

Cause

Correction

STEP 1

Air intake system restriction to air compressor is excessive

NOTE: Perform this check **only** if the air compressor is naturally aspirated. Replace the air compressor air cleaner, if installed. Check the air intake piping. Check the engine air intake restriction if the air compressor air inlet is plumbed to the vehicle or equipment intake system. Refer to Procedure 010-031 in Section 10.

OK

Go To Next Step

STEP 2

Air compressor assembly has malfunctioned

Check the air compressor assembly for proper operation. Perform the Air Compressor Diagnostic Test. Refer to Procedure 012-014 in Section 12.

OK

Go To Next Step

STEP 3

Air compressor cylinder head is cracked or porous, or has a leaking gasket

Inspect the air compressor air inlet and outlet tubes for signs of coolant. Refer to Procedure 012-003 in Section 12. If signs of coolant are present, inspect air compressor cylinder head. Refer to Procedure 012-007 in Section 12.

OK

Go To Next Step

STEP 4

Carbon buildup is excessive in the air discharge line or downstream air valves

NOTE: Perform this check **only** if the air compressor is naturally aspirated. Check for carbon buildup. Replace the air compressor discharge line and clean the air compressor cylinder head as necessary. Refer to Procedure 012-003 in Section 12.

OK

Go To Next Step

STEP 5

Air governor is malfunctioning or not set correctly

Check the air governor for correct operation. Refer to Procedure 012-017 in Section 12 and the OEM service manual.

OK

Go To Next Step

STEP 6

Air system component is malfunctioning

Check the operation of the air system valves, air dryers, and other OEM-installed air system components. Refer to the OEM service manual.

OK

Go To Next Step

STEP 7

Air system leaks

Check for leaks from the air compressor gaskets, air system hoses, fittings, tanks, and valves. Refer to Procedure 012-019 in Section 12 and the OEM service manual. For vehicles equipped with air assisted aftertreatment components, check for leaks in the air supply lines.

Air Compressor Cycles Frequently

This is symptom tree t005

Cause

STEP 1

Air compressor assembly has malfunctioned

OK

Go To Next Step

STEP 2

Air governor is malfunctioning or not set correctly

OK

Go To Next Step

STEP 3

Air system component is malfunctioning

OK

Go To Next Step

STEP 4

Air system leaks

Correction

Check the air compressor assembly for proper operation. Perform the Air Compressor Diagnostic Test. Refer to Procedure 012-014 in Section 12.

Check the air governor for correct operation. Refer to Procedure 012-017 in Section 12, Procedure 012-018 in Section 12, and the OEM service manual. Some OEM installations may **not** utilize an air governor, thus frequent cycling may be expected and normal. Refer to the OEM service manual.

Check the operation of the air system valves, air dryers, and other OEM-installed air system components. Refer to the OEM service manual.

Check for leaks from the air compressor gaskets, air system hoses, fittings, tanks, and valves. Refer to Procedure 012-019 in Section 12 and the OEM service manual. For vehicles equipped with air assisted aftertreatment components, check for leaks in the air supply lines.

Air Compressor Noise is Excessive

This is symptom tree t006

Cause	Correction
<p>STEP 1 Ice buildup in the air system components</p>	<p>Check for ice in low sections of the air discharge line.</p>
<p>OK Go To Next Step</p>	
<p>STEP 2 Carbon buildup is excessive in the air discharge line or downstream air valves</p>	<p>Perform this check only if the air compressor is naturally aspirated. Check for carbon buildup. Clean or replace the air compressor discharge line, if necessary. Check the turbocharger for oil leaks. Check the air compressor intake tube for oil. Refer to Procedure 012-003 in Section 12.</p>
<p>OK Go To Next Step</p>	
<p>STEP 3 Air compressor is sending air pulses into the air tanks</p>	<p>Install a ping tank between the air dryer and the wet tank. Refer to the OEM service manual.</p>
<p>OK Go To Next Step</p>	
<p>STEP 4 Air compressor mounting hardware is loose, worn, or broken</p>	<p>Inspect all mounting hardware and brackets for being loose, worn, or broken. Refer to Procedure 012-014 in Section 12.</p>
<p>OK Go To Next Step</p>	
<p>STEP 5 Air compressor drive gear is adjusted incorrectly</p>	<p>Load the air compressor and apply pressure to the hydraulic power steering pump by turning the wheel. If the noise goes away, the engine gear train is not adjusted correctly and needs to be adjusted. Refer to Procedure 001-012 in Section 12.</p>
<p>OK Go To Next Step</p>	
<p>STEP 6 Air compressor drive gear or engine gear train is worn, damaged, or adjusted incorrectly</p>	<p>Inspect the air compressor drive gear and engine gear train, and repair or adjust as necessary. Refer to Procedure 012-014 in Section 12 and Procedure 001-012 in Section 1.</p>
<p>OK Go To Next Step</p>	
<p>STEP 7 Air compressor is excessively worn or internally damaged</p>	<p>Replace the air compressor. Replace the desiccant element on the air dryer, if equipped. Refer to Procedure 012-014 in Section 12 and the OEM service manual.</p>

Air Compressor Pumping Excess Lubricating Oil into the Air System

This is symptom tree t007

Cause

Correction

STEP 1

Lubricating oil drain interval is excessive

Verify the correct lubricating oil drain interval. Refer to Oil Drain Interval in the Operation and Maintenance Manual, ISBe and ISB (Common Rail Fuel System), Bulletin 3666496. Refer to Procedure 102-002 in Section 2.

OK

Go To Next Step

STEP 2

Lubricating oil is contaminated with coolant or fuel

Refer to the Lubricating Oil Contaminated symptom tree in Section TS.

OK

Go To Next Step

STEP 3

Air intake system restriction to air compressor is excessive

Check the air compressor intake piping. Check the engine air intake restriction. Refer to Procedure 010-031 in Section 10.

OK

Go To Next Step

STEP 4

Contaminants are **not** being drained from the system on a regular basis

Drain the reservoirs daily. Refer to the OEM service manual.

OK

Go To Next Step

STEP 5

Air compressor pumping time is excessive

Check for all air system leaks and repair if found. Refer to Procedure 012-014 and Procedure 012-019 in Section 12, and the OEM service manual.

OK

Go To Next Step

STEP 6

Air compressor pumping too high

Check the air governor for correct operation. Refer to the OEM service manual.

OK

Go To Next Step

STEP 7

Carbon buildup is excessive in the air discharge line, air system valves, or cylinder head

Check for carbon buildup. Clean or replace the air compressor discharge line if necessary. Check the turbocharger for oil leaks. Check the intake tube for oil. Refer to Procedure 012-003 in Section 12.

OK

Go To Next Step

STEP 8

Perform the oil carry-over test and inspect the intake system for restriction.

Perform the air compressor carry-over test. Refer to Procedure 012-020 in Section 12. If the compressor passes the test, inspect the compressor intake system for restrictions.

OK

Go To Next Step

Air Compressor Pumping Excess Lubricating Oil into the Air System

This is symptom tree t007

Cause	Correction
<p>STEP 9 Engine angularity during operation exceeds specification</p>	<p>Refer to the Engine Specification data sheet.</p>
<p>OK Go To Next Step</p>	
<p>STEP 10 Crankcase pressure is excessive</p>	<p>Check for excessive blowby. Refer to the Crankcase Gases (blowby) Excessive symptom tree in Section TS.</p>
<p>OK Go To Next Step</p>	
<p>STEP 11 Lubricating oil pressure is above specification</p>	<p>Check the oil pressure. Refer to the Lubricating Oil Pressure High symptom tree in Section TS.</p>
<p>OK Go To Next Step</p>	
<p>STEP 12 Air compressor runs hot</p>	<p>If coolant temperature is above normal, refer to the Coolant Temperature Above Normal - Gradual Overheat symptom tree in Section TS.</p>
<p>OK Go To Next Step</p>	
<p>STEP 13 Lubricating oil drain line is restricted</p>	<p>Remove the air compressor and check the oil drain holes in the air compressor and the accessory drive. Refer to Procedure 012-014 in Section 12.</p>
<p>OK Go To Next Step</p>	
<p>STEP 14 Air compressor drive gear or engine gear train is worn or damaged</p>	<p>Inspect the drive gears and gear train. Repair as necessary. Refer to Procedure 012-014 in Section 12.</p>
<p>OK Go To Next Step</p>	
<p>STEP 15 Air compressor is excessively worn or internally damaged</p>	<p>Inspect the air compressor. Refer to Procedure 012-014 in Section 12.</p>

Air Compressor Will Not Maintain Adequate Air Pressure (Not Pumping Continuously)

This is symptom tree t008

Cause

Correction

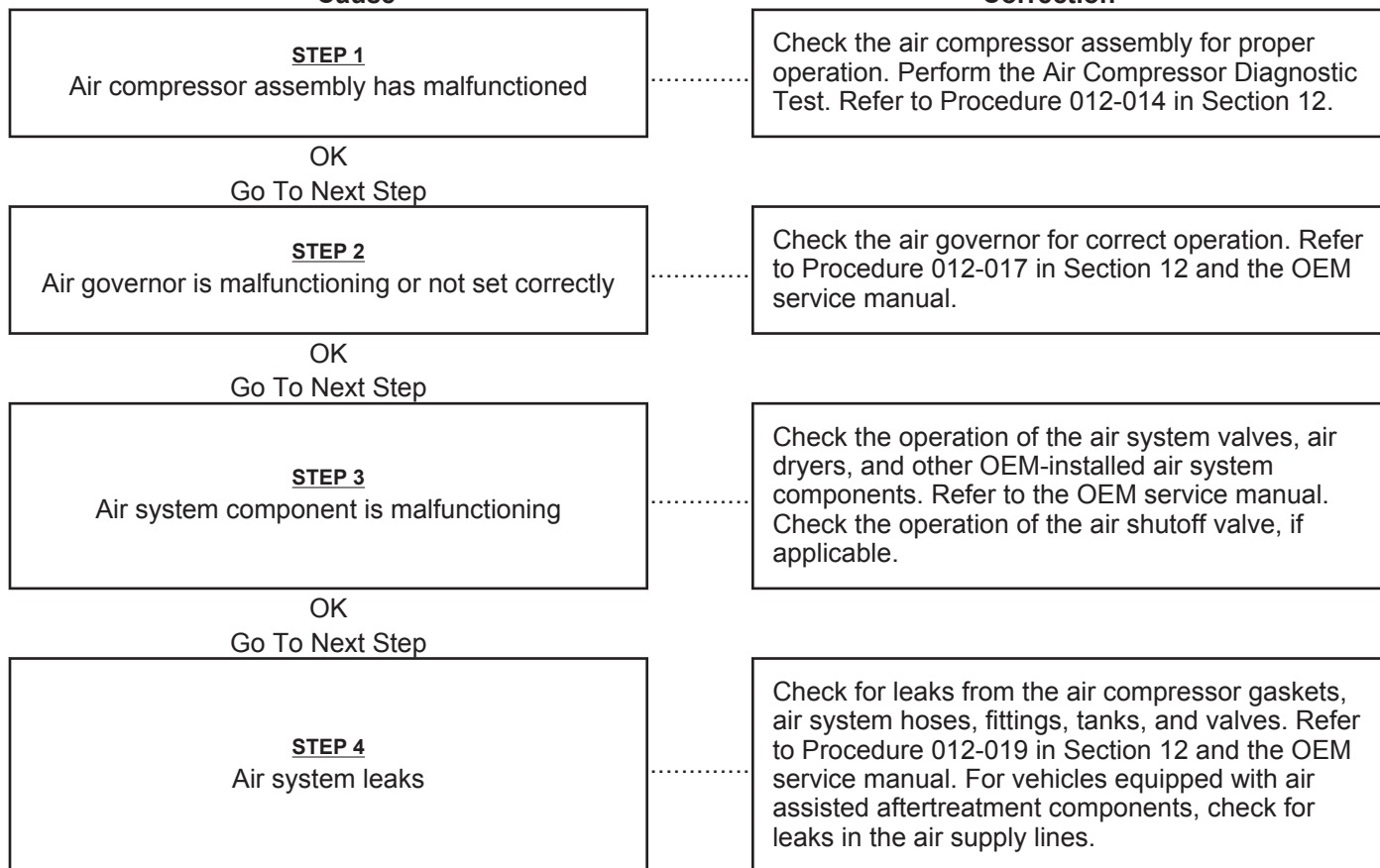

Air Compressor Will Not Pump Air

This is symptom tree t009

Cause

Correction

STEP 1

Air intake system restriction to air compressor is excessive

NOTE: Perform this check **only** if the air compressor is naturally aspirated. Replace the air compressor air cleaner, if installed. Check the air intake piping. Check the engine air intake restriction if the air compressor air inlet is plumbed to the vehicle or equipment intake system. Refer to Procedure 010-031 in Section 10.

OK

Go To Next Step

STEP 2

Air compressor assembly has malfunctioned

Inspect the air compressor air inlet and outlet tubes for signs of coolant. Refer to Procedure 012-003 in Section 12. If signs of coolant are present, inspect the air compressor cylinder. Refer to Procedure 012-017 in Section 12. Check the air compressor assembly for proper operation. Perform the Air Compressor Diagnostic Test. Refer to Procedure 012-014 in Section 12.

OK

Go To Next Step

STEP 3

Carbon buildup is excessive in the air discharge line or downstream air valves

NOTE: Perform this check **only** if the air compressor is naturally aspirated. Check for carbon buildup. Replace the air compressor discharge line and clean the air compressor cylinder head as necessary. Refer to Procedure 012-003 in Section 12.

OK

Go To Next Step

STEP 4

Air governor is malfunctioning or not set correctly

Check the air governor for correct operation. Refer to Procedure 012-017 in Section 12 and in the OEM service manual.

OK

Go To Next Step

STEP 5

Air system component is malfunctioning

Check the operation of the air system valves, air dryers, and other OEM-installed air system components. Refer to the OEM service manual.

OK

Go To Next Step

STEP 6

Air system leaks

Check for leaks from the air compressor gaskets, air system hoses, fittings, tanks, and valves. Refer to Procedure 012-019 in Section 12, and the OEM service manual.. For vehicles equipped with air assisted aftertreatment components, check for leaks in the air supply lines.

OK

Go To Next Step

Air Compressor Will Not Pump Air

This is symptom tree t009

Cause

STEP 7

Air compressor is excessively worn or internally damaged

Correction

Inspect the air compressor. Refer to Procedure 012-014 in Section 12.

Air Compressor Will Not Stop Pumping

This is symptom tree t010

Cause

Correction

STEP 1

Air compressor assembly has malfunctioned

Check the air compressor assembly for proper operation. Perform the Air Compressor Diagnostic Test. Refer to Procedure 012-014 in Section 12.

OK

Go To Next Step

STEP 2

Air governor is malfunctioning or not set correctly

Check the air governor for correct operation. Refer to Procedure 012-017 in Section 12, Procedure 012-018 in Section 12, and the OEM service manual.

OK

Go To Next Step

STEP 3

Air system component is malfunctioning

Check the operation of the air system valves, air dryers, and other OEM-installed air system components. Refer to the OEM service manual. Check the operation of the air shutoff valve, if applicable.

OK

Go To Next Step

STEP 4

Air system leaks

Check for leaks from the air compressor gaskets, air system hoses, fittings, tanks, and valves. Refer to Procedure 012-019 in Section 12 and the OEM service manual. For vehicles equipped with air assisted aftertreatment components, check for leaks in the air supply lines.

Alternator Not Charging or Insufficient Charging

This is symptom tree t013

Cause	Correction
<p>STEP 1 Vehicle gauge is malfunctioning</p>	<p>Check the vehicle gauge. Refer to the OEM service manual.</p>
<p>OK Go To Next Step</p>	
<p>STEP 2 Engine speed too low for charging</p>	<p>Move the throttle to raise the engine speed to 1200 rpm to excite the alternator. Refer to the corresponding Owners Manual or Operation and Maintenance Manual for the engine being serviced to verify correct engine idle speed and operation.</p>
<p>OK Go To Next Step</p>	
<p>STEP 3 Alternator belt is loose</p>	<p>Check the alternator belt tension. Refer to Procedure Procedure 013-001.</p>
<p>OK Go To Next Step</p>	
<p>STEP 4 Electrical system is "open" (blown fuses, broken wires, or loose connections)</p>	<p>Check the fuses, wires, and connections. Refer to the OEM service manual and the manufacturer's wiring diagrams.</p>
<p>OK Go To Next Step</p>	
<p>STEP 5 Battery cables or connections are loose, broken, or corroded (excessive resistance)</p>	<p>Check the battery cables and connections. Refer to Procedure Procedure 013-009.</p>
<p>OK Go To Next Step</p>	
<p>STEP 6 Batteries have malfunctioned</p>	<p>Check the condition of the batteries. Replace the batteries, if necessary. Refer to Procedure Procedure 013-007.</p>
<p>OK Go To Next Step</p>	
<p>STEP 7 Alternator pulley is loose on the shaft</p>	<p>Tighten the pulley. Refer to the alternator manufacturers and / or OEM instructions.</p>
<p>OK Go To Next Step</p>	
<p>STEP 8 Battery temperature is above specification</p>	<p>Position the batteries away from heat sources. Refer to the OEM service manual.</p>
<p>OK Go To Next Step</p>	
<p>STEP 9 Alternator or voltage regulator is malfunctioning</p>	<p>Test the alternator output. Replace the alternator or voltage regulator, if necessary. Refer to Procedure Procedure 013-001 and the OEM service manual.</p>
<p>OK Go To Next Step</p>	

Alternator Not Charging or Insufficient Charging

This is symptom tree t013

Cause

STEP 10

Alternator is overloaded, or alternator capacity is below specification

OK

Go To Next Step

STEP 11

Electronic fault codes active or high counts of inactive fault codes

Correction

Install an alternator with a higher capacity. Refer to Procedure Procedure 013-001 and the OEM service manual.

Read the fault codes with an electronic service tool. Refer to the corresponding Electronic Control System Troubleshooting and Repair Manual for the engine being serviced.

Alternator Overcharging

This is symptom tree t014

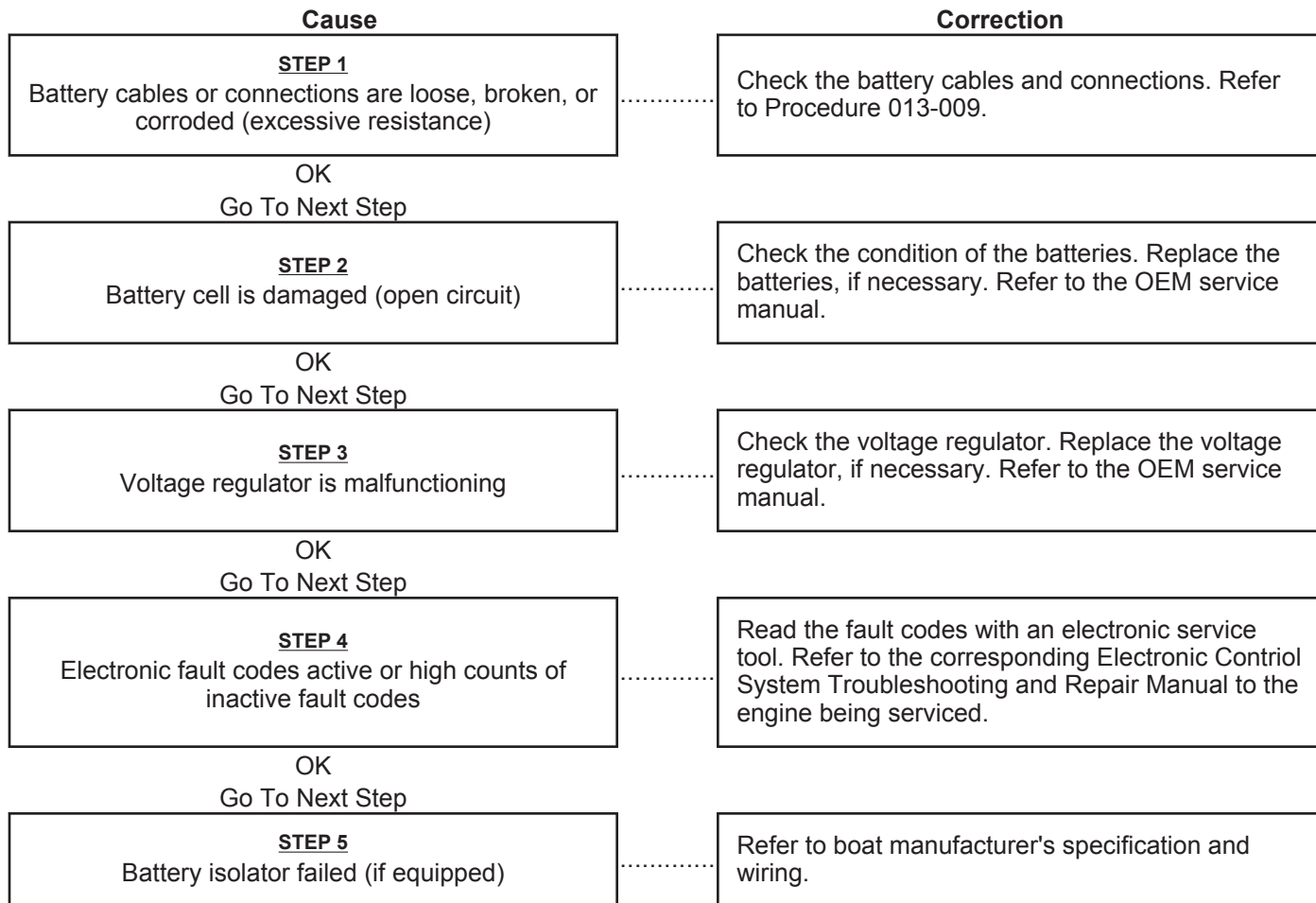

Coolant Loss - External

This is symptom tree t020

Cause	Correction
<p>STEP 1 Coolant level is above specification</p>	<p>Check the coolant level. Refer to Procedure 008-018.</p>
<p>OK Go To Next Step</p>	
<p>STEP 2 External coolant leak</p>	<p>Inspect the engine for coolant leaking from hoses, drain cocks, water manifold, jumper tubes, expansion and pipe plugs, fittings, EGR cooler coolant supply and return tubes, EGR cooler vent lines, turbocharger coolant supply and return lines, EGR valve coolant supply and return lines, EGR cooler, EGR valve, radiator core, air compressor and cylinder head gaskets, lubricating oil cooler, water pump seal, and OEM-mounted components that have coolant flow. If necessary, pressure-test the cooling system. Refer to Procedure 008-020.</p>
<p>OK Go To Next Step</p>	
<p>STEP 3 Radiator cap is not correct, is malfunctioning, or has low-pressure rating</p>	<p>Check the radiator pressure cap. Refer to Procedure 008-047 and the OEM service manual.</p>
<p>OK Go To Next Step</p>	
<p>STEP 4 Cooling system hose is collapsed, restricted, or leaking</p>	<p>Inspect the hoses. Refer to Procedure 008-045.</p>
<p>OK Go To Next Step</p>	
<p>STEP 5 Fill line or vent lines are restricted, obstructed, or not routed correctly</p>	<p>Check the vent lines and the fill line for correct routing and for restriction. Refer to the OEM service manual.</p>
<p>OK Go To Next Step</p>	
<p>STEP 6 Incorrect OEM plumbing routing, resulting in loss of coolant through the radiator overflow</p>	<p>Review plumbing to be positive that no high -pressure coolant can cause backflow in the fill line. Refer to the OEM service manual.</p>
<p>OK Go To Next Step</p>	
<p>STEP 7 Engine is overheating</p>	<p>Refer to the Coolant Temperature Above Normal - Gradual Overheat symptom tree or the Coolant Temperature is Above Normal - Sudden Overheat symptom tree .</p>
<p>OK Go To Next Step</p>	

Coolant Loss - External

This is symptom tree t020

Cause

STEP 8

Air or combustion gases are entering the cooling system

OK

Go To Next Step

STEP 9

Wet exhaust manifold and turbine housing leaking coolant

Correction

Check for air or combustion gases in the cooling system. Refer to Procedure 008-020.

Pressure-test the coolant system. Refer to Procedure 008-020.

Coolant Loss - Internal

This is symptom tree t021

Cause	Correction
<p>STEP 1 Radiator cap is not correct, is malfunctioning, or has low-pressure rating</p>	<p>Check the radiator pressure cap. Refer to Procedure 008-047 in Section 8.</p>
<p>OK Go To Next Step</p>	
<p>STEP 2 Lubricating oil cooler is leaking</p>	<p>Check the lubricating oil cooler for coolant leaks. Refer to Procedure 007-003 in Section 7.</p>
<p>OK Go To Next Step</p>	
<p>STEP 3 Air compressor cylinder head is cracked or porous, or has a leaking gasket</p>	<p>Inspect the air compressor air inlet and outlet tubes for signs of coolant. Refer to Procedure 012-007 in Section 12.</p>
<p>OK Go To Next Step</p>	
<p>STEP 4 EGR cooler leaking coolant</p>	<p>Check the EGR cooler for leaks. Refer to Procedure 011-019 in Section 11.</p>
<p>OK Go To Next Step</p>	
<p>STEP 5 Internal coolant leaks</p>	<p>Pressure test the cooling system and look for internal coolant leaks. Refer to Procedure 008-020 in Section 8.</p>
<p>OK Go To Next Step</p>	
<p>STEP 6 Variable Geometry Turbocharger leaking coolant</p>	<p>Pressure test the cooling system and look for internal coolant leaks. Refer to Procedure 008-020 in Section 8.</p>
<p>OK Go To Next Step</p>	
<p>STEP 7 Cylinder head gasket is leaking</p>	<p>Check the cylinder head gasket. Refer to Procedure 002-004 in Section 2 to remove the cylinder head gasket and inspect.</p>
<p>OK Go To Next Step</p>	
<p>STEP 8 Cylinder head is cracked or porous</p>	<p>Pressure test the cylinder head. Refer to Procedure 002-004 in Section 2.</p>
<p>OK Go To Next Step</p>	
<p>STEP 9 Cylinder block is cracked or porous</p>	<p>Inspect the cylinder block. Refer to Procedure 001-026 in Section 1.</p>

Coolant Temperature Above Normal - Gradual Overheat

This is symptom tree t022

Cause	Correction
<p>STEP 1 Electronic fault codes active or high counts of inactive fault codes</p> <p>OK Go To Next Step</p>	<p>View and troubleshoot the fault codes with INSITE™. Refer to the corresponding Electronic Control SystemT roublesleshooting and Repair Manual for the engine being serviced.</p>
<p>STEP 2 Cold weather radiator cover or winterfront is closed</p> <p>OK Go To Next Step</p>	<p>Open the cold weather radiator cover or the winterfront. Refer to the OEM instrucions</p>
<p>STEP 3 Radiator shutters are not opening completely, or the shutterstat setting is wrong</p> <p>OK Go To Next Step</p>	<p>Inspect the radiator shutters. Repair or replace if necessary. Check the shutterstat setting. Refer to the OEM service manual.</p>
<p>STEP 4 Charge air cooler fins, radiator fins, or air conditioner condenser fins are damaged or obstructed with debris</p> <p>OK Go To Next Step</p>	<p>Inspect the charge air cooler, air conditioner condenser, and radiator fins. Clean, if necessary. Refer to Procedure 010-027 and the OEM service manual.</p>
<p>STEP 5 Coolant level is below specification</p> <p>OK Go To Next Step</p>	<p>Inspect the engine and cooling system for external coolant leaks. Repair if necessary. Add coolant. Refer to Procedures 008-018 and the Coolant Leak External Sympton Tree .</p>
<p>STEP 6 Coolant mixture of antifreeze and water is not correct</p> <p>OK Go To Next Step</p>	<p>Verify the concentration of antifreeze in the coolant. Add antifreeze or water to correct the concentration. Refer to the Cummins Coolant Requirements and Maintenance, Bulletin 3666132.</p>
<p>STEP 7 Sea water cooling system is malfunctioning</p> <p>OK Go To Next Step</p>	<p>Troubleshoot the sea water system. Refer to the Coolant Temperature Above Normal - Sea Water Cooling System sympton tree.</p>
<p>STEP 8 Fan shroud is damaged or missing or the air recirculation baffles are damaged or missing</p> <p>OK Go To Next Step</p>	<p>Inspect the shroud and the recirculation baffles. Repair, replace, or install, if necessary. Refer to Procedure 008-038.</p>

Coolant Temperature Above Normal - Gradual Overheat

This is symptom tree t022

Cause	Correction
<p>STEP 9 Fan drive belt is broken or loose</p>	<p>Check the fan drive belt. Replace the belt if necessary. Refer to Procedure 008-002.</p>
<p>OK Go To Next Step</p>	
<p>STEP 10 Fan drive or fan controls are malfunctioning</p>	<p>Check the fan drive and controls. Refer to Procedure 008-027 if electronically controlled by the engine's ECM. If OEM controlled, refer to the OEM service manual.</p>
<p>OK Go To Next Step</p>	
<p>STEP 11 Coolant temperature gauge or sensor is malfunctioning</p>	<p>Test the gauge and the sensor. Repair or replace, if necessary. Refer to the OEM service manual instructions on troubleshooting the gauge. Refer to the corresponding Electronic Control System Troubleshooting and Repair Manual for the engine being serviced, to monitor and check the coolant temperature sensor..</p>
<p>OK Go To Next Step</p>	
<p>STEP 12 Radiator cap is not correct, is malfunctioning, or has low-pressure rating</p>	<p>Check the radiator pressure cap. Refer to Procedure 008-047.</p>
<p>OK Go To Next Step</p>	
<p>STEP 13 Thermostat is not correct or is malfunctioning</p>	<p>Check the thermostat for the correct part number and for correct operation. Refer to Procedure 008-013.</p>
<p>OK Go To Next Step</p>	
<p>STEP 14 Cooling system hose is collapsed, restricted, or leaking</p>	<p>Inspect the hoses. Refer to Procedure 008-045.</p>
<p>OK Go To Next Step</p>	
<p>STEP 15 Fill line or vent lines are restricted, obstructed, or not routed correctly</p>	<p>Check the vent lines and the fill line for correct routing and for restriction. Refer to the OEM service manual.</p>
<p>OK Go To Next Step</p>	
<p>STEP 16 Intake manifold air temperature is above specification</p>	<p>Refer to the Intake Manifold Air Temperature Above Specification symptom tree .</p>
<p>OK Go To Next Step</p>	

Coolant Temperature Above Normal - Gradual Overheat

This is symptom tree t022

Cause	Correction
<p>STEP 17 Lubricating oil level is above or below specification</p>	<p>Check the oil level. Add or drain oil, if necessary. Refer to Procedure 007-043.</p>
<p>OK Go To Next Step</p>	
<p>STEP 18 Cooling system is contaminated with dirt, scale, or sludge</p>	<p>Clean the cooling system. Refer to Procedure 008-018.</p>
<p>OK Go To Next Step</p>	
<p>STEP 19 Lubricating oil is contaminated with coolant or fuel</p>	<p>Refer to the Lubricating Oil Contaminated symptom tree .</p>
<p>OK Go To Next Step</p>	
<p>STEP 20 Coolant is contaminated with lubricating oil</p>	<p>Refer to the Lubricating or Transmission Oil in Coolant symptom tree .</p>
<p>OK Go To Next Step</p>	
<p>STEP 21 Water pump is malfunctioning</p>	<p>Check the block pressure. Replace the water pump if necessary. Refer to Procedure 008-020 or 008-062.</p>
<p>OK Go To Next Step</p>	
<p>STEP 22 Radiator core is internally obstructed or damaged, or the check valve or J-tube is malfunctioning</p>	<p>Inspect the radiator and clean if necessary. Refer to Procedure 008-042.</p>
<p>OK Go To Next Step</p>	
<p>STEP 23 Torque converter is malfunctioning</p>	<p>Check the torque converter. Refer to the OEM service manual.</p>
<p>OK Go To Next Step</p>	
<p>STEP 24 Torque converter cooler or hydraulic oil cooler is malfunctioning</p>	<p>Remove and inspect the cooler cores and o-rings. Refer to the OEM service manual.</p>
<p>OK Go To Next Step</p>	
<p>STEP 25 Vehicle cooling system is not adequate</p>	<p>Verify that the engine and vehicle cooling systems are using the correct components. Refer to the OEM service manual.</p>
<p>OK Go To Next Step</p>	

Coolant Temperature Above Normal - Gradual Overheat

This is symptom tree t022

Cause

STEP 26

Air or combustion gases are entering the cooling system

Correction

Check for air or combustion gases in the cooling system. Refer to Procedure 008-020.

Coolant Temperature Above Normal - Sudden Overheat

This is symptom tree t023

Cause

Correction

STEP 1

Electronic fault codes active or high counts of inactive fault codes

View and troubleshoot the fault codes with INSITE™. Refer to the corresponding Electronic Control System Troubleshooting and Repair manual for the engine being serviced..

OK

Go To Next Step

STEP 2

Coolant level is below specification

Inspect the engine and cooling system for external coolant leaks. Repair if necessary. Add coolant. Refer to Procedure 008-018 and Procedure008-020 the Coolant Leak External Symptom Tree .

OK

Go To Next Step

STEP 3

Fan drive belt is broken or loose

Check the fan drive belt. Replace the belt if necessary. Refer to Procedure 008-002.

OK

Go To Next Step

STEP 4

Cold weather radiator cover or winterfront is closed

Open the cold weather radiator cover or the winterfront. Refer to the OEM Manual

OK

Go To Next Step

STEP 5

Radiator shutters are **not** opening completely, or the shutterstat setting is wrong

Inspect the radiator shutters. Repair or replace if necessary. Check the shutterstat setting. Refer to the OEM service manual.

OK

Go To Next Step

STEP 6

Charge air cooler fins, radiator fins, or air conditioner condenser fins are damaged or obstructed with debris

Inspect the charge air cooler, air conditioner condenser, and radiator fins. Clean, if necessary. Refer to Procedure 010-027.

OK

Go To Next Step

STEP 7

Thermostat is **not** correct or is malfunctioning

Check the thermostat for the correct part number and for correct operation. Refer to Procedure 008-013.

OK

Go To Next Step

STEP 8

Coolant temperature gauge is malfunctioning

Test the temperature gauge. Repair or replace the gauge, if necessary. Refer to the OEM service manual.

OK

Go To Next Step

Coolant Temperature Above Normal - Sudden Overheat

This is symptom tree t023

Cause

Correction

STEP 9
Coolant temperature gauge or sensor is malfunctioning

Test the gauge and the sensor. Repair or replace, if necessary. Refer to the OEM service manual instructions on troubleshooting the gauge. Refer to the corresponding Electronic Control System Troubleshooting and Repair Manual for the engine being serviced, to monitor and check the coolant temperature sensor..

OK
Go To Next Step

STEP 10
Sea water cooling system is malfunctioning

Troubleshoot the sea water system. Refer to the Coolant Temperature Above Normal - Sea Water Cooling System symptom tree.

OK
Go To Next Step

STEP 11
Cooling system hose is collapsed, restricted, or leaking

Inspect the hoses. Refer to Procedure 008-045.

OK
Go To Next Step

STEP 12
Fill line or vent lines are restricted, obstructed, or **not** routed correctly

Check the vent lines and the fill line for correct routing and for restriction. Refer to the OEM service manual.

OK
Go To Next Step

STEP 13
Water pump is malfunctioning

Check the block pressure. Replace the water pump if necessary. Refer to Procedure 008-020 or 008-062.

OK
Go To Next Step

STEP 14
Radiator cap is **not** correct, is malfunctioning, or has low-pressure rating

Check the radiator pressure cap. Refer to Procedure 008-047.

OK
Go To Next Step

STEP 15
Fan drive or fan controls are malfunctioning

Check the fan drive and controls. Refer to Procedure 008-027 if electronically controlled by the engine's ECM. If OEM controlled, refer to the OEM service manual.

OK
Go To Next Step

STEP 16
Cooling system component is malfunctioning

Perform the cooling system diagnostics test. Refer to Procedure 008-020.

OK
Go To Next Step

Coolant Temperature Above Normal - Sudden Overheat

This is symptom tree t023

Cause

STEP 17

Torque converter cooler or hydraulic oil cooler is malfunctioning

Correction

Remove and inspect the cooler cores and o-rings.
Refer to the OEM service manual.

Coolant Temperature Below Normal

This is symptom tree t024

Cause

Correction

STEP 1

Engine is operating at low ambient temperature

Check the winterfront, shutters, and under-the-hood air. Use under-the-hood intake air in cold weather. Refer to the OEM service manual.

OK

Go To Next Step

STEP 2

Electronic fault codes active or high counts of inactive fault codes

View and troubleshoot the fault codes with INSITE™. Refer to the corresponding Electronic Control System Troubleshooting and Repair Manual for the engine being serviced.

OK

Go To Next Step

STEP 3

Coolant temperature gauge or sensor is malfunctioning

Test the gauge and the sensor. Repair or replace, if necessary. Refer to the OEM service manual.

OK

Go To Next Step

STEP 4

Coolant temperature gauge or sensor is malfunctioning

Test the gauge and the sensor. Repair or replace, if necessary. Refer to the OEM service manual instructions on troubleshooting the gauge. See the corresponding Electronic Control System Troubleshooting and Repair Manual for the engine being serviced, to monitor and check the coolant temperature sensor..

OK

Go To Next Step

STEP 5

Excessive coolant flow through OEM plumbing and heater cores

Close valves to heater cores. Run engine. If engine operates at normal temperature, refer to the OEM service manual.

OK

Go To Next Step

STEP 6

Thermostat is **not** correct or is malfunctioning

Check the thermostat for the correct part number and for correct operation. Refer to Procedure 008-013.

OK

Go To Next Step

STEP 7

Fan drive or fan controls are malfunctioning

Check the fan drive and controls. Refer to Procedure 008-027 if electronically controlled by the engine's ECM. If OEM controlled, refer to the OEM service manual.

OK

Go To Next Step

Coolant Temperature Below Normal

This is symptom tree t024

Cause

Correction

STEP 8
Engine idle time is excessive

Low oil and coolant temperatures can be caused by long idle time (greater than 10 minutes). Shut off the engine rather than idle for long periods. If idle time is necessary, raise the idle speed. Procedure 008-027 if electronically controlled by the engine's ECM. If OEM controlled, refer to the OEM service manual

OK
Go To Next Step

STEP 9
Cooling system component is malfunctioning

Perform the cooling system diagnostics test. Refer to Procedure 008-020.

Coolant in the Lubricating Oil

This is symptom tree t025

Cause	Correction
<p>STEP 1 Lubricating oil cooler is malfunctioning</p>	<p>Check the oil cooler. Refer to Procedure 007-003.</p>
<p>OK Go To Next Step</p>	
<p>STEP 2 Air compressor cylinder head is cracked or porous, or has a leaking gasket</p>	<p>Inspect the air compressor cylinder head and gasket. Refer to Procedure 012-007. If the air compressor head is not serviceable, replace the air compressor. Refer to Procedure 012-014 .</p>
<p>OK Go To Next Step</p>	
<p>STEP 3 Internal coolant leaks</p>	<p>Refer to Procedure 008-020 to pressure test the cooling system and look for internal coolant leaks..</p>
<p>OK Go To Next Step</p>	
<p>STEP 4 Variable Geometry Turbo leaking coolant</p>	<p>Refer to Procedure 008-020 to pressure test the cooling system and look for internal coolant leaks..</p>
<p>OK Go To Next Step</p>	
<p>STEP 5 Cylinder head gasket is leaking</p>	<p>Check the cylinder head gasket. Refer to Procedure 002-004 to remove the cylinder head and inspect..</p>
<p>OK Go To Next Step</p>	
<p>STEP 6 Cylinder head is cracked or porous</p>	<p>Pressure-test the cylinder head. Refer to Procedure 002-004.</p>
<p>OK Go To Next Step</p>	
<p>STEP 7 Cylinder block is cracked or porous</p>	<p>Inspect the cylinder block. Refer to Procedure 001-026.</p>

Coolant Temperature Above Normal - Sea Water Cooling System

This is symptom tree t026-156

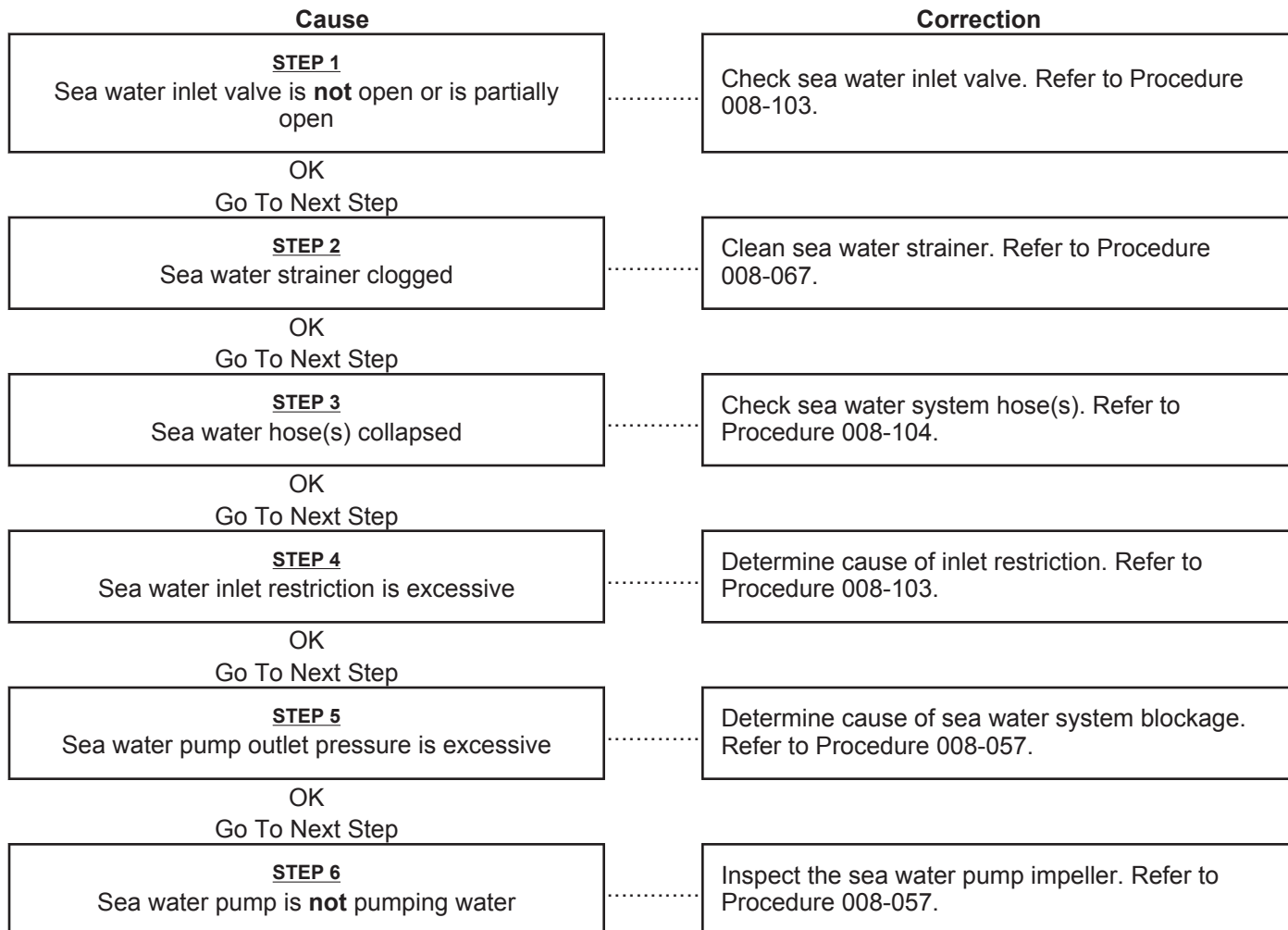

Crankcase Gases (Blowby) Excessive

This is symptom tree t027

The symptom of excessive Crankcase Gases (Blow-by) can also be referred to carryover or excessive amounts of oil out of the crankcase breather tube. This symptom tree covers both of these symptoms.

Cause

Correction

STEP 1

Lubricating oil level is above specification

Check the oil level. Verify the dipstick calibration and oil pan capacity. Fill the system to the specified level.

OK

Go To Next Step

STEP 2

Crankcase ventilation system is plugged

Check and clean the crankcase breather and vent tube. Refer to Procedure 003-001 in Section 3, Procedure 003-002 in Section 3, and Procedure 003-018 in Section 3.

OK

Go To Next Step

STEP 3

Engine angularity during operation exceeds specification

Refer to the Engine Specification Data Sheet for angularity specifications for the engine being serviced. For marine applications, see Recreational Installation directions for Marine Engines, Bulletin 3884649.

OK

Go To Next Step

STEP 4

Air compressor is excessively worn or internally damaged

Replace or rebuild the air compressor. Refer to Procedure 014-010 in Section 14 to check the air compressor engine blowby contribution. If blowby is out of specification; Refer to Procedure 012-014 in Section 12.

OK

Go To Next Step

STEP 5

Exhaust brake adjustment is **not** correct

Check the exhaust brake adjustment. Refer to Procedure 020-016 in Section 20 to measure exhaust back pressure with the exhaust brake operating. If above specification, repair or replace the exhaust brake.

OK

Go To Next Step

STEP 6

Turbocharger oil seal is leaking

Check the turbocharger compressor and turbine seals. Refer to Procedure 014-010 in Section 14 to check the turbocharger blow-by contribution. Replace the turbocharger if necessary. Refer to Procedure 010-033 in Section 10.

OK

Go To Next Step

STEP 7

Valve stem clearance is excessive or the valve stem seals are damaged

Check the valve stems and seals. Refer to Procedure 002-004 in Section 2.

OK

Go To Next Step

Crankcase Gases (Blowby) Excessive

This is symptom tree t027

The symptom of excessive Crankcase Gases (Blow-by) can also be referred to carryover or excessive amounts of oil out of the crankcase breather tube. This symptom tree covers both of these symptoms.

Cause

Correction

STEP 8

Cylinder head valve guides are excessively worn

Check the valve guides for wear. Replace the cylinder head, if necessary. Refer to Procedure 002-004 in Section 2.

OK

Go To Next Step

STEP 9

Piston or piston rings are worn or damaged

Check for air intake system leaks. Refer to Procedure 010-024 in Section 10. Check the pistons and piston rings for wear or damage. For piston cleaning and reuse; Refer to Procedure 001-043 in Section 1. For cylinder block inspection and reuse; Refer to Procedure 001-026 in Section 1. For piston ring inspection; Refer to Procedure 001-047 in Section 1.

Cranking Fuel Pressure is Low

This is symptom tree t029

Cause	Correction
<p>STEP 1 Fuel level is low in the tank</p>	<p>Fill the supply tank. Refer to the OEM service manual.</p>
<p>OK Go To Next Step</p>	
<p>STEP 2 Fuel filter is plugged</p>	<p>Measure the fuel pressure before and after the fuel filter. Refer to Procedure 005-011.</p>
<p>OK Go To Next Step</p>	
<p>STEP 3 Fuel leak</p>	<p>Check the fuel lines, fuel connections, and fuel filters for leaks. Check the fuel lines to the supply tanks. Refer to the OEM service manual.</p>
<p>OK Go To Next Step</p>	
<p>STEP 4 Fuel inlet restriction</p>	<p>Check for fuel inlet restriction. Refer to Procedure 006-020.</p>
<p>OK Go To Next Step</p>	
<p>STEP 5 Air in the fuel system</p>	<p>Check for air in the fuel system. Completely vent air from the fuel system. Refer to Procedure 006-003.</p>
<p>OK Go To Next Step</p>	
<p>STEP 6 Fuel connections on the suction side of the pump are loose</p>	<p>Tighten all the fuel fittings and connections between the fuel tanks and fuel pump.</p>
<p>OK Go To Next Step</p>	
<p>STEP 7 Fuel suction standpipe in the fuel tank is broken</p>	<p>Check and repair the standpipe, if necessary. Refer to the OEM service manual.</p>
<p>OK Go To Next Step</p>	
<p>STEP 8 Gear pump is malfunctioning</p>	<p>Check the gear pump output pressure. Replace the gear pump if necessary. Refer to Procedure 005-011 and 005-025.</p>
<p>OK Go To Next Step</p>	
<p>STEP 9 Fuel pump is malfunctioning</p>	<p>Check the fuel pump output pressure with INSITE™, an electronic service tool. Replace the fuel pump if necessary. Refer to Procedure 005-016.</p>

Engine Decelerates Slowly

This is symptom tree t041

Cause

Correction

STEP 1

Electronic fault codes active or high counts of inactive fault codes

Refer to Section TF in the Troubleshooting and Repair Manual, Electronic Control System, ISB (4 cylinder) and ISB^e (4 and 6 cylinder) Series Engines, Bulletin 3666477 for fault code troubleshooting.

OK

Go To Next Step

STEP 2

Electronic control module system is **not** calibrated or has incorrect calibration

Compare the calibration in the electronic control system with the engine rating and the Control Parts List (CPL), Bulletin 3379133 or 4021327. If necessary, calibrate the system. Refer to the Troubleshooting and Repair Manual, Electronic Control System, ISB (4 cylinder) and ISB^e (4 and 6 cylinder) Series Engines, Bulletin 3666477.

OK

Go To Next Step

STEP 3

Accelerator pedal or lever is restricted or malfunctioning

Check the percent accelerator pedal or lever reading on an electronic service tool. Verify that it reads 100 percent with the accelerator pedal depressed and 0 percent when released. Check the remote accelerator pedal. Calibrate the accelerator pedal if possible. Refer to the Troubleshooting and Repair Manual, Electronic Control System, ISB (4 cylinder) and ISB^e (4 and 6 cylinder) Series Engines, Bulletin 3666477.

OK

Go To Next Step

STEP 4

Injector is malfunctioning

Perform the single-cylinder cutout test. Replace the injectors as necessary. Refer to Procedure 006-026 or 014-008.

OK

Go To Next Step

STEP 5

J1939 control devices are interfering with the engine controls

Alternately disconnect all other J1939 control devices from the datalink circuit until communication or functionality is restored. Refer to the Troubleshooting and Repair Manual, Electronic Control System, ISB (4 cylinder) and ISB^e (4 and 6 cylinder) Series Engines, Bulletin 3666477.

OK

Go To Next Step

STEP 6

Clutch is malfunctioning or is **not** correct

Compare the drivetrain specifications to Cummins recommendations. Check the clutch for correct operation. Refer to the OEM service manual.

Engine Noise Excessive

This is symptom tree t047

When troubleshooting engine noise complaints, make sure the engine accessories (air compressor, fan clutch, refrigerant compressor, or hydraulic pump) are not the cause of the noise. Refer to Engine Noise Diagnostic Procedures - General Information at the end of Section TS before using this symptom tree.

Cause

Correction

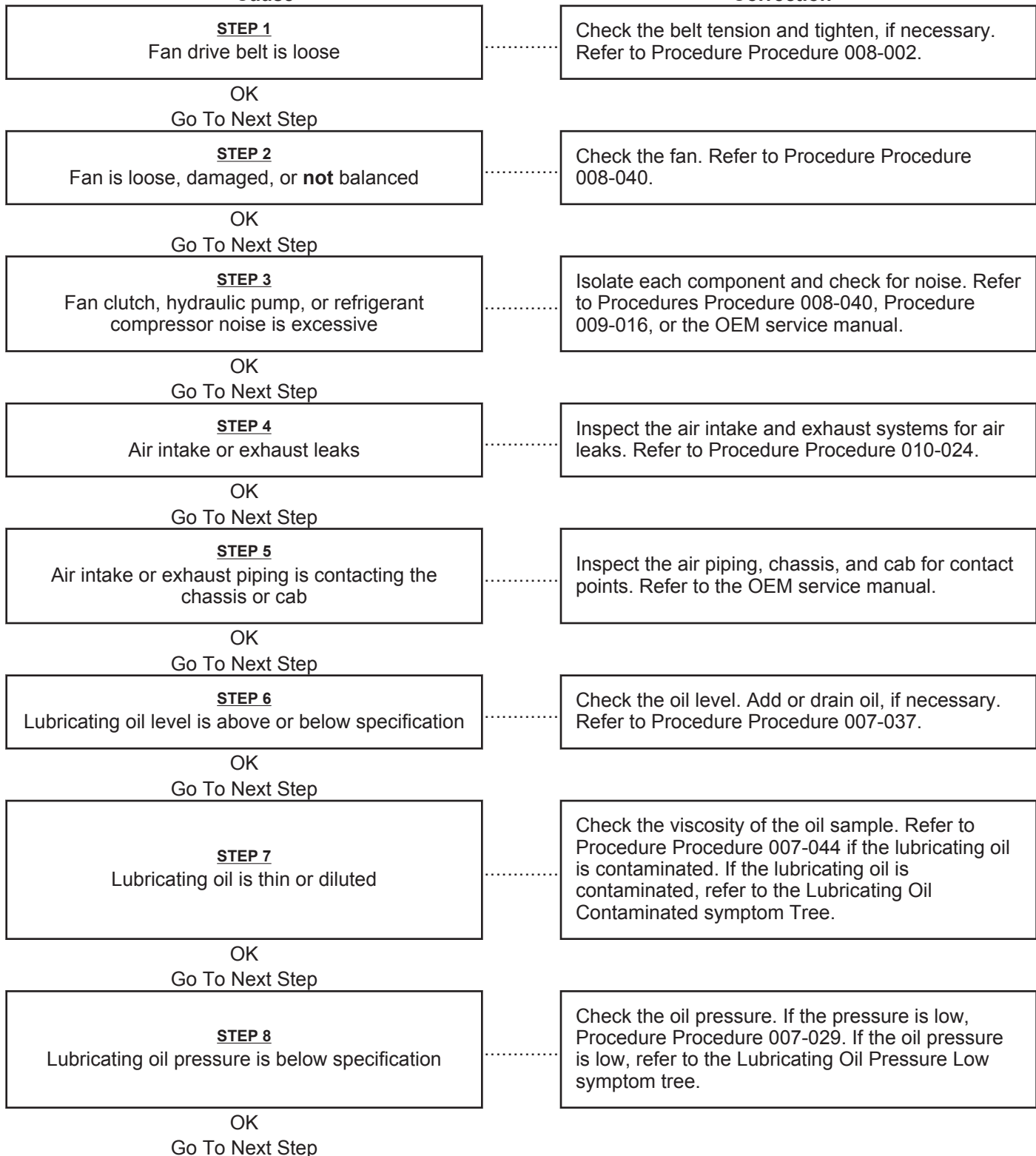

Engine Noise Excessive

This is symptom tree t047

When troubleshooting engine noise complaints, make sure the engine accessories (air compressor, fan clutch, refrigerant compressor, or hydraulic pump) are not the cause of the noise. Refer to Engine Noise Diagnostic Procedures - General Information at the end of Section TS before using this symptom tree.

Cause

Correction

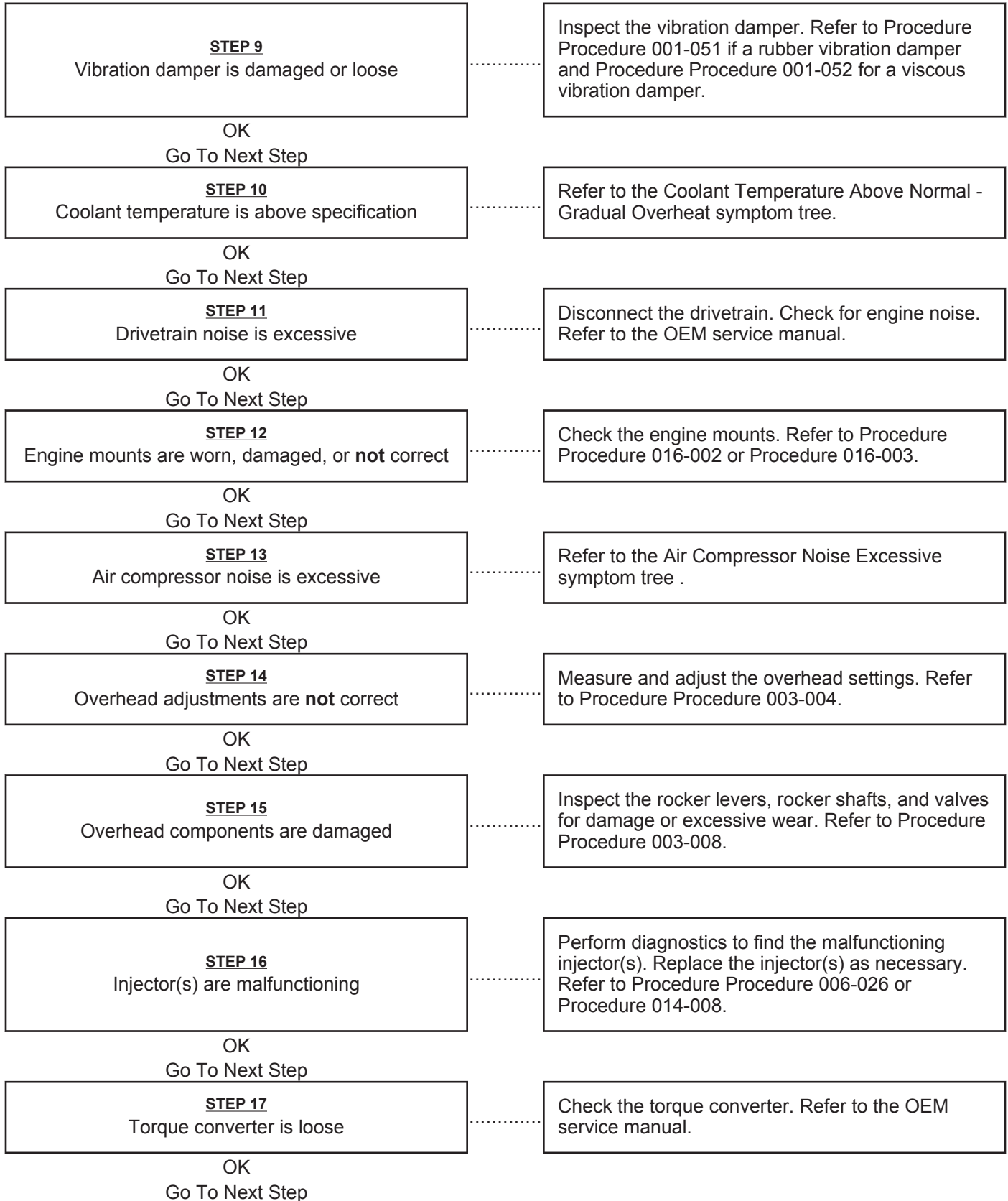

Engine Noise Excessive

This is symptom tree t047

When troubleshooting engine noise complaints, make sure the engine accessories (air compressor, fan clutch, refrigerant compressor, or hydraulic pump) are not the cause of the noise. Refer to Engine Noise Diagnostic Procedures - General Information at the end of Section TS before using this symptom tree.

Cause

Correction

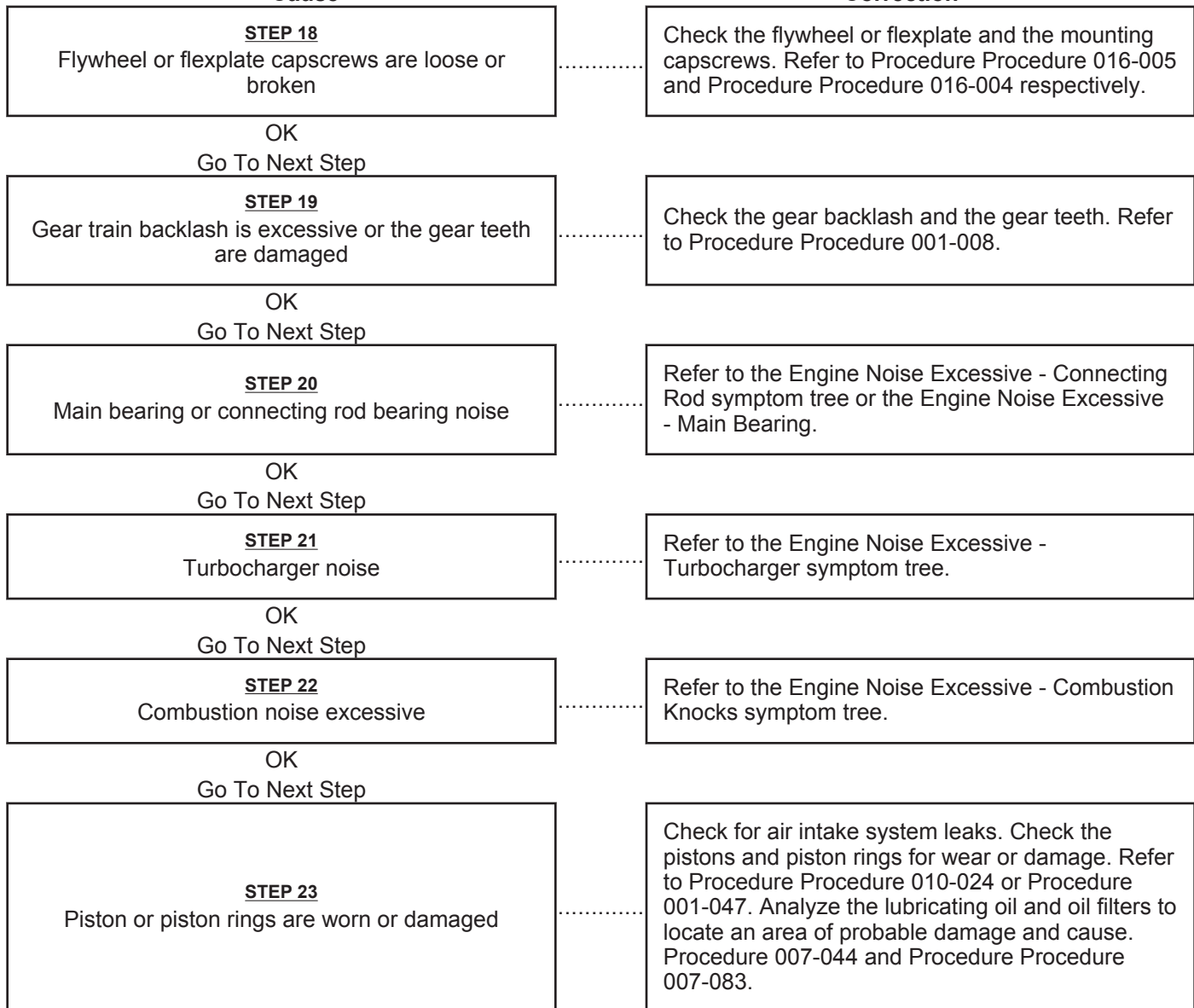

Engine Noise Excessive — Combustion Knocks

This is symptom tree t048

Refer to Engine Noise Diagnostic Procedures - General Information at the end of Section TS before using this symptom tree.

Cause	Correction
<p>STEP 1 Electronic fault codes active or high counts of inactive fault codes</p>	<p>View and troubleshoot the fault codes with INSITE™. Refer to the corresponding Electronic Control System Troubleshooting and Repair Manual for the engine being serviced.</p>
<p>OK Go To Next Step</p>	
<p>STEP 2 Fuel grade is not correct for the application or the fuel quality is poor</p>	<p>Operate the engine from a tank of high-quality fuel. Refer to the Owners Manual or Operation and Maintenance Manual corresponding to the engine being serviced for fuel specifications.</p>
<p>OK Go To Next Step</p>	
<p>STEP 3 Air in the fuel system</p>	<p>Check for air in the fuel system. Refer to Procedure 006-003.</p>
<p>OK Go To Next Step</p>	
<p>STEP 4 Coolant temperature is above specification</p>	<p>Refer to Coolant Temperature Above Normal — Gradual Overheat Symptom tree .</p>
<p>OK Go To Next Step</p>	
<p>STEP 5 Overhead adjustments are not correct</p>	<p>Measure and adjust the overhead settings. Refer to Procedure 003-004.</p>
<p>OK Go To Next Step</p>	
<p>STEP 6 Injector is malfunctioning</p>	<p>Perform the single-cylinder cutout test. Replace the injectors as necessary. Refer to Procedures 006-026 and 014-008 .</p>
<p>OK Go To Next Step</p>	
<p>STEP 7 Camshaft timing is not correct (after engine rebuild or repair)</p>	<p>Check the gear train timing alignment. Refer to Procedure 001-008.</p>
<p>OK Go To Next Step</p>	
<p>STEP 8 Piston is misassembled</p>	<p>Remove and inspect the piston. Refer to Procedure 002-004 the cylinder head and inspect the orientation and tops of the pistons for debris. Procedure 001-054 for piston orientation and if necessary, piston removal.</p>

Engine Noise Excessive — Connecting Rod

This is symptom tree t049

Refer to Engine Noise Diagnostic Procedures - General Information at the end of Section TS before using this symptom tree.

Cause	Correction
<p>STEP 1 Electronic fault codes active or high counts of inactive fault codes</p>	<p>View and troubleshoot the fault codes with INSITE™. Refer to the corresponding Electronic Control System Troubleshooting and Repair Manual for the engine being serviced.</p>
<p>OK Go To Next Step</p>	
<p>STEP 2 Lubricating oil level is below specification</p>	<p>Check the oil level. Verify the dipstick calibration and the oil pan capacity. Fill the system to the specified level. Refer to Procedures 007-043 and 007-009.</p>
<p>OK Go To Next Step</p>	
<p>STEP 3 Lubricating oil is thin or diluted</p>	<p>Refer to Procedure 007-044 to check if the oil is contaminated. If the lubrication oil is contaminated, see the Lubricating Oil Contaminated symptom tree .</p>
<p>OK Go To Next Step</p>	
<p>STEP 4 Lubricating oil pressure is below specification</p>	<p>Check the oil pressure. If the pressure is low, refer to the Lubricating Oil Pressure Low symptom tree .</p>
<p>OK Go To Next Step</p>	
<p>STEP 5 Lubricating oil suction or transfer tube misassembled</p>	<p>Remove and inspect the lubricating oil suction or transfer tube. Refer to Procedure 007-035.</p>
<p>OK Go To Next Step</p>	
<p>STEP 6 Block stiffener plate is misassembled</p>	<p>Remove and inspect block stiffener plate. Refer to Procedure 001-089.</p>
<p>OK Go To Next Step</p>	
<p>STEP 7 Connecting rod capscrews are loose or not tightened correctly</p>	<p>Check the torque on the connecting rod capscrews. Refer to Procedure 001-014.</p>
<p>OK Go To Next Step</p>	
<p>STEP 8 Connecting rod and bearings are damaged or worn, are not assembled correctly, or are the wrong bearings</p>	<p>Inspect the connecting rod and bearings. Refer to Procedure 001-014.</p>
<p>OK Go To Next Step</p>	

Engine Noise Excessive — Connecting Rod

This is symptom tree t049

Refer to Engine Noise Diagnostic Procedures - General Information at the end of Section TS before using this symptom tree.

Cause

STEP 9

Connecting rod is bent or out of alignment

OK

Go To Next Step

STEP 10

Crankshaft journals are damaged or out of round

Correction

Remove and inspect the connecting rods. Refer to Procedure 001-014.

Inspect the crankshaft journals. Refer to Procedure 001-016.

Engine Noise Excessive — Main Bearing

This is symptom tree t050

Refer to Engine Noise Diagnostic Procedures - General Information at the end of Section TS before using this symptom tree.

Cause	Correction
<p>STEP 1 Electronic fault codes active or high counts of inactive fault codes</p>	<p>View and troubleshoot the fault codes with INSITE™. Refer to the corresponding Electronic Control System Troubleshooting and Repair Manual for the engine being serviced.</p>
<p>OK Go To Next Step</p>	
<p>STEP 2 Lubricating oil level is below specification</p>	<p>Check the oil level. Verify the dipstick calibration and the oil pan capacity. Fill the system to the specified level. Refer to Procedures 007-043 and 007-009.</p>
<p>OK Go To Next Step</p>	
<p>STEP 3 Lubricating oil is thin or diluted</p>	<p>Refer to Procedure 007-044 to check if the lubricating oil is contaminated . If the lubricating oil is contaminated see the Lubricating Oil Contaminated symptom tree .</p>
<p>OK Go To Next Step</p>	
<p>STEP 4 Lubricating oil pressure is below specification</p>	<p>Check the oil pressure. If the pressure is low, refer to Procedure 007-029 If the oil pressure is low, see the Lubricating Oil Pressure Low symptom tree .</p>
<p>OK Go To Next Step</p>	
<p>STEP 5 Main bearing capscrews are loose, worn or not tightened correctly</p>	<p>Check the torque on the main bearing capscrews. Inspect the capscrews for wear. Refer to Procedure 001-006.</p>
<p>OK Go To Next Step</p>	
<p>STEP 6 Main bearings are damaged or worn, or the wrong bearings are installed</p>	<p>Inspect the main bearings for damage, excessive wear, and the correct part number. Refer to Procedure 001-006.</p>
<p>OK Go To Next Step</p>	
<p>STEP 7 Crankshaft journals are damaged or out of round</p>	<p>Inspect the crankshaft journals. Refer to Procedure 001-016.</p>
<p>OK Go To Next Step</p>	
<p>STEP 8 Flywheel or flexplate capscrews are loose or broken</p>	<p>Check the flywheel or flexplate and the mounting capscrews. Refer to Procedures 016-004 and 016-005.</p>

Engine Noise Excessive — Piston

This is symptom tree t051

Refer to Engine Noise Diagnostic Procedures - General Information at the end of Section TS before using this symptom tree.

Cause	Correction
<p>STEP 1 Electronic fault codes active or high counts of inactive fault codes</p>	<p>View and troubleshoot the fault codes with INSITE™. Refer to the corresponding Electronic Control System Troubleshooting and Repair Manual for the engine being serviced..</p>
<p>OK Go To Next Step</p>	
<p>STEP 2 Fuel grade is not correct for the application or the fuel quality is poor</p>	<p>Operate the engine from a tank of high-quality fuel. Refer to the Owners Manual or Operation and Maintenance Manual corresponding to the engine being serviced for fuel specifications.</p>
<p>OK Go To Next Step</p>	
<p>STEP 3 Overhead adjustments are not correct</p>	<p>Measure and adjust the overhead settings. Refer to Procedure 003-004.</p>
<p>OK Go To Next Step</p>	
<p>STEP 4 Injector is malfunctioning</p>	<p>Perform the single-cylinder cutout test. Replace the injectors as necessary. Refer to Procedures 006-026 and 014-008 .</p>
<p>OK Go To Next Step</p>	
<p>STEP 5 Piston is misassembled</p>	<p>Remove and inspect the piston. Refer to Procedure 002-004 the cylinder head and inspect the orientation and tops of the pistons for debris. Procedure 001-054 for piston orientation and if necessary, piston removal.</p>
<p>OK Go To Next Step</p>	
<p>STEP 6 Connecting rod is bent or out of alignment</p>	<p>Remove and inspect the connecting rods. Refer to Procedure 001-014.</p>
<p>OK Go To Next Step</p>	
<p>STEP 7 Connecting rod is misassembled</p>	<p>Remove and inspect the connecting rod. Refer to Procedure 001-014.</p>
<p>OK Go To Next Step</p>	
<p>STEP 8 Piston pin or bushing is loose, worn, or not installed correctly</p>	<p>Remove the pistons and inspect the piston pin and bushing for damage, wear, and correct installation. Refer to Procedure 001-043 or 001-054.</p>

Engine Noise Excessive - Turbocharger

This is symptom tree t052

Refer to Engine Noise Diagnostic Procedures - General Information, in the troubleshooting overview procedure at the beginning of Section TS, before using this symptom tree.

Cause

Correction

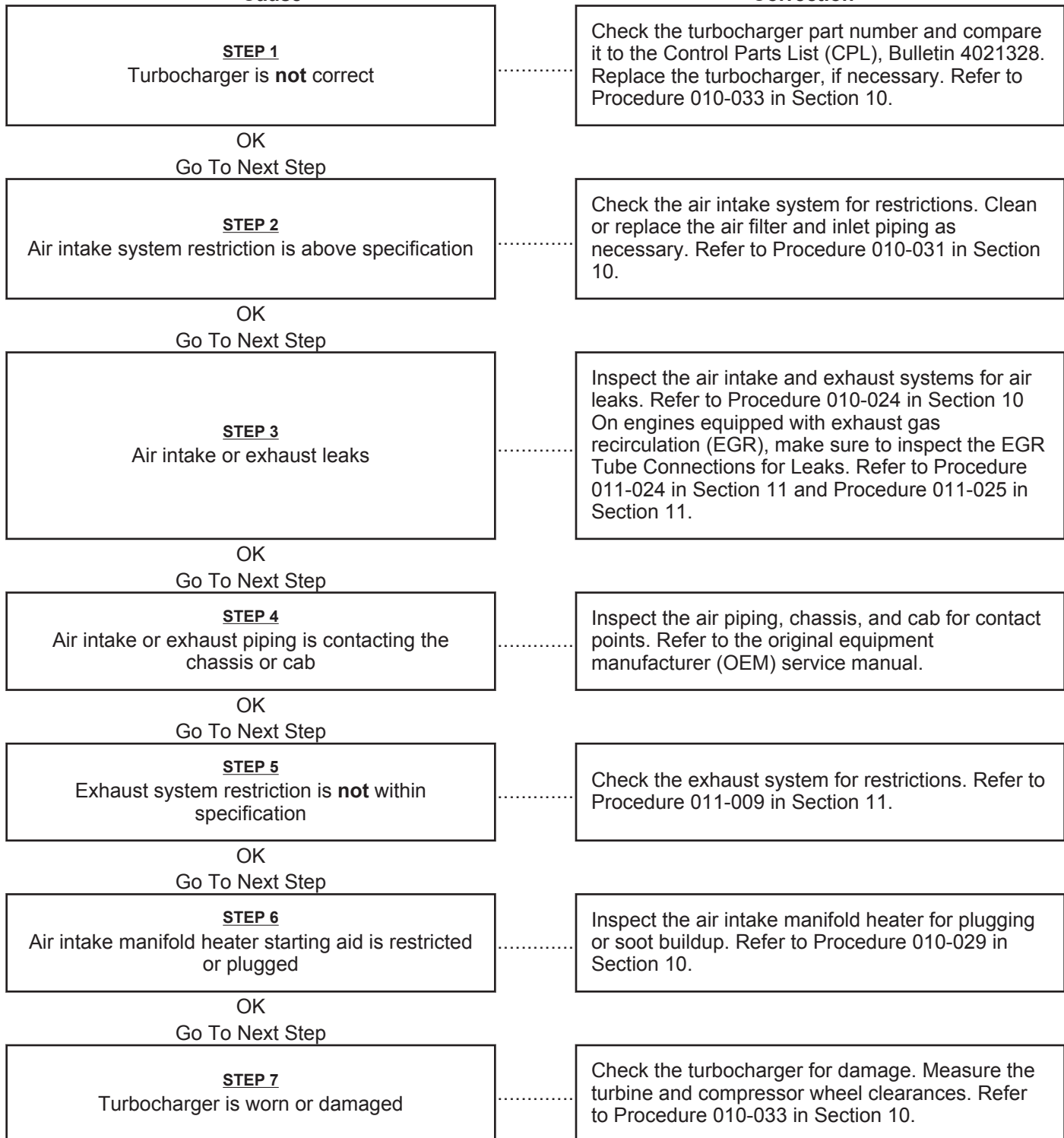

Engine Speed Surges in PTO or Cruise Control

This is symptom tree t068

Cause

Correction

STEP 1

Fuel level is low in the tank

Fill the supply tank. Refer to the OEM service manual.

OK

Go To Next Step

STEP 2

Electronic fault codes active or high counts of inactive fault codes

Refer to the corresponding Electronic Control System and Repair Manual for the engine being serviced. View and troubleshoot the fault codes with INSITE™.

OK

Go To Next Step

STEP 3

Fast Idle Warm Up feature is activating

If enabled, monitor Fast Idle Warm Up Status with INSITE™ while vehicle is operating in PTO mode. Refer to the corresponding Troubleshooting and Repair Manual for the engine being serviced .

OK

Go To Next Step

STEP 4

Fuel leak

Check the fuel lines, fuel connections, and fuel filters for leaks. Check the fuel lines to the supply tanks. Refer to the OEM service manual.

OK

Go To Next Step

STEP 5

Fuel inlet restriction

Check for fuel inlet restriction. Refer to Procedure 006-020.

OK

Go To Next Step

STEP 6

Fuel filter or fuel suction inlet restriction

Check the flow through the fuel filter. Replace the fuel filter if necessary. Refer to Procedure 006-015 to check if the fuel filter is restricted.

OK

Go To Next Step

STEP 7

Air in the fuel system

Check for air in the fuel system. Refer to Procedure 006-003.

OK

Go To Next Step

Engine Speed Surges in PTO or Cruise Control

This is symptom tree t068

Cause

Correction

STEP 8

Electronic control module (ECM) calibration is malfunctioning

Verify the electronic control module (ECM) calibration is correct. Check the calibration revision history for applicable fixes to the calibration stored in the ECM. Refer to the calibration history spreadsheet ecm_calibration_rev_history.xlsx on QuickServe® Online Internet Website or the INCAL™ calibration CD. Compare the calibration stored in the ECM with the engine rating and the Control Parts List (CPL), Bulletin 4021326 or 4021327. If necessary, recalibrate the ECM. Refer to Procedure 019-032 in the corresponding Troubleshooting and Repair Manual for the engine being serviced.

OK

Go To Next Step

STEP 9

Programmable parameters or selected features are **not** correct

Check the programmable parameters and the selected features with an electronic service tool. Set the parameters and features again if necessary. Refer to Procedure 019-078 in the corresponding Troubleshooting and Repair Manual for the engine being serviced.

OK

Go To Next Step

STEP 10

J1939 control devices are interfering with the engine controls

Alternately disconnect all other J1939 control devices from the datalink circuit until communication or functionality is restored. Refer to OEM service manual to locate and repair J1939 control devices.

OK

Go To Next Step

STEP 11

Vehicle or vessel system integration module is malfunctioning

Refer to OEM service manual to replace the system integration module..

OK

Go To Next Step

STEP 12

Accelerator pedal or lever is restricted or malfunctioning

Check the percent accelerator pedal or lever reading on an electronic service tool. Verify that it reads 100 percent with the accelerator pedal depressed and 0 percent when released. Calibrate the accelerator if possible. Replace the accelerator pedal if necessary. Refer to OEM service manual and/or Procedure 019-085 in the corresponding Troubleshooting and Repair Manual for the engine being serviced.

OK

Go To Next Step

Engine Speed Surges in PTO or Cruise Control

This is symptom tree t068

Cause

STEP 13

Moisture in the wiring harness connectors

OK

Go To Next Step

STEP 14

Vehicle parasitics are excessive

OK

Go To Next Step

STEP 15

Engine speed sensor or circuit is malfunctioning

OK

Go To Next Step

STEP 16

Engine position sensor (EPS) or circuit is malfunctioning

OK

Go To Next Step

STEP 17

Vehicle speed sensor (VSS) or circuit is malfunctioning

OK

Go To Next Step

STEP 18

Fuel heater is malfunctioning (if equipped)

OK

Go To Next Step

STEP 19

Fuel connector is leaking fuel

OK

Go To Next Step

Correction

Dry the connectors with Cummins electronic cleaner, Part Number 3824510.

Check the vehicle brakes for dragging, transmission malfunction, cooling fan operation cycle time, and engine-driven units. Refer to OEM service manual.

Check the engine speed sensor for correct adjustment and for debris on the sensor. Check the engine speed sensor circuit. Refer to Procedure 019-042 in the corresponding Troubleshooting and Repair Manual for the engine being serviced.

Check the engine position sensor and circuit. Refer to Procedure 019-038 in the corresponding Electronic Control System Troubleshooting and Repair manual for the engine being serviced.

Use an electronic service tool to monitor the vehicle speed while the vehicle is **not** moving. Refer to the appropriate electronic service tool manual. If the monitor shows speed, check the sensor and circuit. Refer to Procedures 019-090 and 019-091 in the corresponding Troubleshooting and Repair Manual for the engine being serviced .

Check the fuel heater and replace if necessary. Refer to Procedure 005-008.

Measure the drain line fuel quantity. Inspect the fuel connector and injector for nicks or damage that can cause fuel leaks. Refer to Procedures 006-026 and 006-052.

Engine Speed Surges in PTO or Cruise Control

This is symptom tree t068

Cause

Correction

<p>STEP 20 Injector sealing washer is not correct</p>	<p>Remove the injectors and verify the injector sealing washer thickness. Refer to Procedure 006-026.</p>
<p>OK Go To Next Step</p>	
<p>STEP 21 Injector is malfunctioning</p>	<p>Perform the single-cylinder cutout test. Replace the injectors as necessary. Refer to Procedures 014-008 and 006-026.</p>
<p>OK Go To Next Step</p>	
<p>STEP 22 Injectors are not correct</p>	<p>Compare the part number of the injector in the cylinder that corresponds to the fault code to the Control Parts List (CPL), Bulletin number 3379133 or 4021327. Replace the injector if necessary. Refer to Procedure 006-026.</p>
<p>OK Go To Next Step</p>	
<p>STEP 23 Clutch is malfunctioning or is not correct</p>	<p>Check the clutch for correct operation. Refer to OEM service manual.</p>
<p>OK Go To Next Step</p>	
<p>STEP 24 Fuel grade is not correct for the application or the fuel quality is poor</p>	<p>Operate the engine from a tank of high-quality fuel. Refer to the owners Manual or Operation and Maintenance Manual corresponding to the engine being serviced for fuel specifications.</p>
<p>OK Go To Next Step</p>	
<p>STEP 25 Turbocharger is not correct</p>	<p>Check the turbocharger part number and compare it to the Control Parts List (CPL), Bulletin 3379133 or 4021327. Replace the turbocharger if necessary. Refer to Procedure 010-033.</p>
<p>OK Go To Next Step</p>	
<p>STEP 26 Turbocharger wastegate is malfunctioning (if equipped)</p>	<p>Check the wastegate for correct operation. Refer to Procedure 010-050 and Procedure 010-033.</p>
<p>OK Go To Next Step</p>	
<p>STEP 27 Turbocharger wheel clearance is out of specification</p>	<p>Check the radial bearing clearance and axial clearance. Inspect the turbocharger. Repair or replace the turbocharger if necessary. Refer to Procedure 010-033.</p>
<p>OK Go To Next Step</p>	

Engine Speed Surges in PTO or Cruise Control

This is symptom tree t068

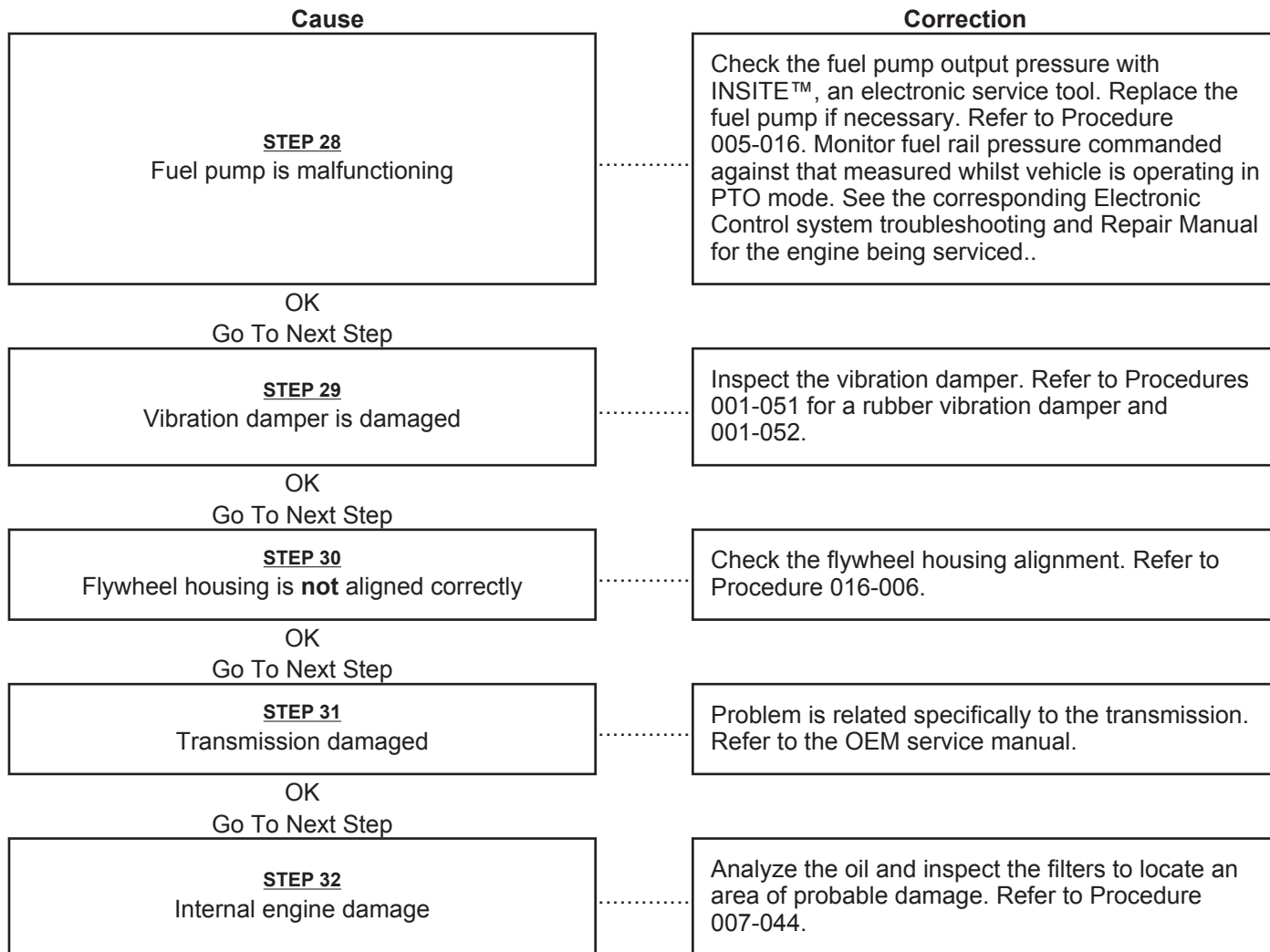

Engine Will Not Crank — (Electric Starter)

This is symptom tree t074-005

Cause	Correction
<p>STEP 1 Electronic fault codes active or high counts of inactive fault codes</p>	<p>Read the fault codes with an electronic service tool. Refer to Section TF in Troubleshooting and Repair Manual, ISB, ISBe2, ISBe3, ISBe4, QSB4.5, QSB5.9, QSB6.7, ISC, QSC8.3, ISL, ISLe3, ISLe4, and QSL9, CM850 Electronic Control System, Bulletin 4021416.</p>
<p>OK Go To Next Step</p>	
<p>STEP 2 Battery voltage is low</p>	<p>Check the battery connections. Refer to Procedure 013-007 in Section 13.</p>
<p>OK Go To Next Step</p>	
<p>STEP 3 Broken, loose, or corroded starting circuit connections</p>	<p>Inspect, clean, and tighten both the positive and negative connections between the starting motor and battery, including the magnetic switch. Refer to Procedure 013-009 in Section 13.</p>
<p>OK Go To Next Step</p>	
<p>STEP 4 Battery capacity is below specification</p>	<p>Refer to Procedure 013-007 in Section 13. Replace the batteries if necessary.</p>
<p>OK Go To Next Step</p>	
<p>STEP 5 OEM starter interlock devices engaged</p>	<p>Check the starter interlock devices. Refer to the OEM service manual.</p>
<p>OK Go To Next Step</p>	
<p>STEP 6 Starting circuit component is malfunctioning</p>	<p>Check the starting circuit components. Refer to the OEM service manual.</p>
<p>OK Go To Next Step</p>	
<p>STEP 7 Starter solenoid does not make an audible sound</p>	<p>Check the magnetic switch and starter solenoid. Refer to Procedures 013-017 and 013-019 in Section 13.</p>
<p>OK Go To Next Step</p>	
<p>STEP 8 Battery cables are not the correct gauge or length</p>	<p>Replace the battery cables with larger gauge or shorter length cables. Refer to the OEM service manual.</p>
<p>OK Go To Next Step</p>	
<p>STEP 9 Engine-driven units are engaged</p>	<p>Disengage engine-driven units.</p>
<p>OK Go To Next Step</p>	

Engine Will Not Crank — (Electric Starter)

This is symptom tree t074-005

Cause	Correction
<p>STEP 10 Starter motor malfunction</p>	<p>Check the voltage drop at the starting motor. Refer to Procedure 013-020 in Section 13.</p>
<p>OK Go To Next Step</p>	
<p>STEP 11 Starting motor pinion or ring gear is damaged</p>	<p>Remove the starting motor, and inspect the gear. Refer to Procedure 013-020 in Section 13.</p>
<p>OK Go To Next Step</p>	
<p>STEP 12 Crankshaft rotation is impaired</p>	<p>Check the crankshaft for ease of rotation. Refer to Procedure 001-016 in Section 1.</p>
<p>OK Go To Next Step</p>	
<p>STEP 13 Hydraulic lock in a cylinder</p>	<p>Remove the injectors and rotate the crankshaft. Look for the source of fluid in the cylinder. Refer to Procedure 006-026 in Section 6.</p>
<p>OK Go To Next Step</p>	
<p>STEP 14 Internal engine damage</p>	<p>Analyze the oil and inspect the filters to locate an area of probable damage. Refer to Procedure 007-083 in Section 7.</p>

Engine Cranks Slowly — (Electric Starter)

This is symptom tree t074-010

Cause	Correction
<p>STEP 1 Batteries are cold</p>	<p>Check the battery heater. Refer to the OEM service manual.</p>
<p>OK Go To Next Step</p>	
<p>STEP 2 Electronic fault codes active or high counts of inactive fault codes</p>	<p>Read the fault codes with an electronic service tool. Refer to Section TF in Troubleshooting and Repair Manual, ISB, ISBe2, ISBe3, ISBe4, QSB4.5, QSB5.9, QSB6.7, ISC, QSC8.3, ISL, ISLe3, ISLe4, and QSL9, CM850 Electronic Control System, Bulletin 4021416.</p>
<p>OK Go To Next Step</p>	
<p>STEP 3 Battery voltage is low</p>	<p>Check the batteries and the unswitched battery supply circuit. Refer to Procedure 013-007 in Section 13.</p>
<p>OK Go To Next Step</p>	
<p>STEP 4 Broken, loose, or corroded starting circuit connections</p>	<p>Inspect, clean, and tighten both the positive and negative connections between the starting motor and battery, including the magnetic switch. Refer to Procedure 013-009 in Section 13.</p>
<p>OK Go To Next Step</p>	
<p>STEP 5 Battery capacity is below specification</p>	<p>Refer to Procedure 013-007 in Section 13. Replace the batteries if necessary.</p>
<p>OK Go To Next Step</p>	
<p>STEP 6 OEM starter interlock devices engaged</p>	<p>Check the starter interlock devices. Refer to the OEM service manual.</p>
<p>OK Go To Next Step</p>	
<p>STEP 7 Lubricating oil pressure switch, gauge, or sensor is malfunctioning or is not in the correct location</p>	<p>Check the oil pressure switch, gauge, or sensor for correct operation and location. Refer to the OEM service manual.</p>
<p>OK Go To Next Step</p>	
<p>STEP 8 Battery cables are not the correct gauge or length</p>	<p>Replace the battery cables with larger gauge or shorter length cables. Refer to the OEM service manual.</p>
<p>OK Go To Next Step</p>	

Engine Cranks Slowly — (Electric Starter)

This is symptom tree t074-010

Cause	Correction
<p>STEP 9 Engine-driven units are engaged</p>	<p>Disengage engine-driven units.</p>
<p>OK Go To Next Step</p>	
<p>STEP 10 Starting circuit component is malfunctioning</p>	<p>Check the starting circuit components. Refer to the OEM service manual.</p>
<p>OK Go To Next Step</p>	
<p>STEP 11 Starter motor malfunction</p>	<p>Check the voltage drop at the starting motor. Refer to Procedure 013-020 in Section 13.</p>
<p>OK Go To Next Step</p>	
<p>STEP 12 Starting motor pinion or ring gear is damaged</p>	<p>Remove the starting motor, and inspect the gear. Refer to Procedure 013-020 in Section 13.</p>
<p>OK Go To Next Step</p>	
<p>STEP 13 Lubricating oil level is above specification</p>	<p>Check the oil level. Verify the dipstick calibration and oil pan capacity. Fill the system to the specified level. Refer to Procedure 007-009 in Section 7.</p>
<p>OK Go To Next Step</p>	
<p>STEP 14 Lubricating oil does not meet specifications for operating conditions</p>	<p>Change the oil and filters. Refer to Procedure 018-003 in Section V. This procedure can be found in the Operation and Maintenance Manual, ISB and ISBe (Common Rail Fuel System), Bulletin 3666496 and the Owners Manual, QSB3.3 CM2150 and B3.3, Bulletin 4021473, to verify the correct lubricating oil is being used.</p>
<p>OK Go To Next Step</p>	
<p>STEP 15 Crankshaft rotation is impaired</p>	<p>Check the crankshaft for ease of rotation. Refer to Procedure 001-016 in Section 1.</p>
<p>OK Go To Next Step</p>	
<p>STEP 16 Internal engine damage</p>	<p>Analyze the oil and inspect the filters to locate an area of probable damage. Refer to Procedure 007-083 in Section 7.</p>

Engine Will Not Crank or Cranks Slowly (Air Starter)

This is symptom tree t077

Cause

Correction

STEP 1

Air pressure is low in the air tanks

Increase air pressure with an external air source. Refer to the OEM service manual.

OK

Go To Next Step

STEP 2

Electronic fault codes active or high counts of inactive fault codes

Read the fault codes with an electronic service tool. Refer to the corresponding Electronic Control System Troubleshooting and Repair Manual for the engine being serviced. View fault codes it INSITE™.

OK

Go To Next Step

STEP 3

OEM starter interlock devices engaged

Check the starter interlock devices. Refer to the OEM service manual.

OK

Go To Next Step

STEP 4

Lubricating oil pressure switch, gauge, or sensor is malfunctioning or is **not** in the correct location

Check the oil pressure switch, gauge, or sensor for correct operation and location. Refer to the OEM service manual.

OK

Go To Next Step

STEP 5

Engine-driven units are engaged

Disengage engine-driven units.

OK

Go To Next Step

STEP 6

Starting motor is malfunctioning or starting motor is **not** correct

Check the starting motor operation. Compare the starting motor with the engine and vehicle specifications. Refer to the OEM service manual.

OK

Go To Next Step

STEP 7

Starting motor pinion or ring gear is damaged

Remove the starting motor, and inspect the gear. Refer to OEM Service Manual.

OK

Go To Next Step

STEP 8

Lubricating oil level is above specification

Check the oil level. Verify the dipstick calibration and oil pan capacity. Fill the system to the specified level. Refer to Procedures 007-009 and 007-043.

OK

Go To Next Step

Engine Will Not Crank or Cranks Slowly (Air Starter)

This is symptom tree t077

Cause

Correction

STEP 9

Lubricating oil does **not** meet specifications for operating conditions

Change the oil and filters. Refer to Procedure 007-037 See the corresponding Owners Manual or Operation and Maintenance Manual to the engine being service for oil specifications .

OK

Go To Next Step

STEP 10

Crankshaft rotation is impaired

Check the crankshaft for ease of rotation. Refer to Procedure 013-020.

OK

Go To Next Step

STEP 11

Hydraulic lock in a cylinder

Remove the injectors and rotate the crankshaft. Look for the source of fluid in the cylinder. Refer to Procedure 006-026.

OK

Go To Next Step

STEP 12

Internal engine damage

Analyze the oil and inspect the filters to locate an area of probable damage. Refer to Procedure 007-044.

Engine Will Not Shut Off

This is symptom tree t081

Cause

Correction

STEP 1

Electronic fault codes active or high counts of inactive fault codes

View and troubleshoot the fault codes with INSITE™. Refer to the corresponding Electronic Control System Troubleshooting and Repair Manual for the engine being serviced..

OK

Go To Next Step

STEP 2

Keyswitch circuit is malfunctioning

Check the vehicle, equipment, or vessel keyswitch circuit. Refer to Procedure 019-064 in the corresponding Electronic Control System Troubleshooting and Repair Manual for the engine being serviced..

OK

Go To Next Step

STEP 3

Turbocharger oil seal is leaking

Check the turbocharger compressor and turbine seals. Refer to Procedure 010-033.

OK

Go To Next Step

STEP 4

Engine is running on fumes drawn into the air intake

Check the air intake ducts. Locate and isolate the source of the fumes. Repair as necessary. Refer to the OEM service manual.

OK

Go To Next Step

STEP 5

Electronic control module (ECM) is malfunctioning

Replace the ECM. Refer to Procedure 019-031 in the Electronic Control System Troubleshooting and Repair Manual for the engine being serviced .

Fuel Consumption Excessive

This is symptom tree t087

Cause

STEP 1

Interview the operator to verify the complaint

OK

Go To Next Step

STEP 2

Operator technique is **not** correct

OK

Go To Next Step

STEP 3

Lubricating oil level is above specification

OK

Go To Next Step

STEP 4

Lubricating oil does **not** meet specifications for operating conditions

OK

Go To Next Step

STEP 5

Hubometer or odometer is miscalibrated

OK

Go To Next Step

STEP 6

Electronic fault codes active or high counts of inactive fault codes

OK

Go To Next Step

STEP 7

Programmable parameters or selected features are **not** correct

OK

Go To Next Step

Correction

Refer to the Driveability/Low Power - Customer Complaint Form at the end of the TS section. Follow the instructions on the form before continuing with this troubleshooting symptom tree.

Explain correct engine operation to the operator. Refer to Section 1 in the Owners Manual or Operation and Maintenance Manual of the engine being serviced.

Check the oil level. Verify the dipstick calibration and oil pan capacity. Fill the system to the specified level. Refer to Procedure 007-009 and Procedure Procedure 007-037 in Section 7.

Change the oil and filters. Refer to Procedure 007-037 in Section 7. See the corresponding Owners Manual or Operation and Maintenance Manual for the engine being serviced for oil specifications.

Check the hubometer and odometer calibrations. Calibrate or replace the hubometer or odometer, if necessary. Calculate fuel consumption with new mileage figures.

View and troubleshoot the fault codes with INSITE™ electronic service tool. Refer to the corresponding Electronic Control System Troubleshooting and Repair manual for the engine being serviced.

Check the programmable parameters and the selected features with an electronic service tool. Set the parameters and features again, if necessary. Refer to Procedure 019-078 in Section 19 in the corresponding Electronic Control System Troubleshooting and Repair Manual for the engine being serviced.

Fuel Consumption Excessive

This is symptom tree t087

Cause	Correction
<p>STEP 8 Engine control module (ECM) calibration is malfunctioning</p>	<p>Verify the ECM calibration is correct. Check the calibration revision history for applicable fixes to the calibration stored in the ECM. Refer to the calibration history spreadsheet on QuickServe™ Online or the INCAL™ CD-ROM. Compare the calibration stored in the ECM with the engine rating and Control Parts List (CPL), Bulletin 4021328. If necessary, calibrate the ECM. Refer to Procedure 019-032 in Section 19 in the corresponding Electronic Control System Troubleshooting and Repair Manual for the engine being serviced.</p>
<p>OK Go To Next Step</p>	
<p>STEP 9 Engine idle or PTO time is excessive</p>	<p>Check the idle or PTO time with INSITE™ electronic service tool. Low oil and coolant temperatures can be caused by excessive idle time (greater than 10 minutes).</p>
<p>OK Go To Next Step</p>	
<p>STEP 10 Auxiliary devices using fuel from vehicle's fuel supply tank(s)</p>	<p>Check the fuel consumption of the auxiliary devices. Refer to the OEM service manual.</p>
<p>OK Go To Next Step</p>	
<p>STEP 11 Fuel cooler is malfunctioning (if equipped)</p>	<p>Check the fuel cooler. Refer to Procedure 006-062 in Section 6.</p>
<p>OK Go To Next Step</p>	
<p>STEP 12 Equipment and environmental factors are affecting fuel consumption</p>	<p>Consider ambient temperatures, wind, tire size, axle alignment, routes, and use of aerodynamic aids when evaluating fuel consumption.</p>
<p>OK Go To Next Step</p>	
<p>STEP 13 Vehicle parasitics are excessive</p>	<p>Check the vehicle for brakes dragging, transmission malfunction, cooling fan operation cycle time, and engine-driven units. Refer to the OEM service manual.</p>
<p>OK Go To Next Step</p>	
<p>STEP 14 Vessel is malfunctioning or parasitics are excessive</p>	<p>Check the vessel's bottom, propeller, transmission, and driven accessories. Refer to the OEM service manual.</p>
<p>OK Go To Next Step</p>	

Fuel Consumption Excessive

This is symptom tree t087

Cause

Correction

STEP 15

Drivetrain is **not** correctly matched to the engine

Check for correct gearing and drivetrain components. Refer to the OEM service manual.

OK

Go To Next Step

STEP 16

Vessel is overloaded or the propeller is incorrect

The vessel **must** be propped to allow engine to reach rated speed (rpm).

OK

Go To Next Step

STEP 17

Intake manifold pressure (boost) sensor or circuit is malfunctioning

Check the boost sensor and circuit. Compare the intake manifold pressure sensor reading in the monitor mode. Use INSITE™ electronic service tool to compare to a manual pressure gauge. Refer to Procedure Procedure 019-159 in Section 19 in the corresponding Electronic Control System Troubleshooting and Repair Manual for the engine being serviced.

OK

Go To Next Step

STEP 18

Vehicle speed sensor (VSS) or circuit is malfunctioning

Refer to the appropriate electronic service tool manual. If the monitor shows speed, check the sensor and circuit. Refer to Procedures Procedure 019-090 and Procedure 019-091 in Section 19 in the corresponding Electronic Control System Troubleshooting and Repair Manual for the engine being serviced.

OK

Go To Next Step

STEP 19

Vehicle speed sensor (VSS) tampering has occurred

Check the vehicle speed sensor and circuit for tampering. Check for Fault Code 242. Repair the circuit as necessary. Refer to Procedures Procedure 019-090 and Procedure 019-091 in Section 19 in the corresponding Electronic Control System Troubleshooting and Repair Manual for the engine being serviced.

OK

Go To Next Step

STEP 20

Fuel leak

Check the fuel lines, fuel connections, and fuel filters for leaks. Check the fuel lines to the supply tanks. Refer to the OEM service manual.

OK

Go To Next Step

STEP 21

Air intake or exhaust leaks

Inspect the air intake and exhaust systems for air leaks. Refer to Procedure Procedure 010-024 in Section 10.

OK

Go To Next Step

Fuel Consumption Excessive

This is symptom tree t087

Cause

Correction

STEP 22

Charge-air cooler is restricted or leaking

Inspect the charge-air cooler for air restrictions or leaks. Refer to Procedure Procedure 010-027 in Section 10.

OK

Go To Next Step

STEP 23

Air intake system restriction is above specification

Check the air intake system for restrictions. Clean or replace the air filter and inlet piping as necessary. Refer to Procedure Procedure 010-031 in Section 10.

OK

Go To Next Step

STEP 24

Exhaust system restriction is **not** within specification

Check the exhaust system for restrictions. Refer to Procedure Procedure 011-009 in Section 11.

OK

Go To Next Step

STEP 25

Fuel grade is **not** correct for the application or the fuel quality is poor

Operate the engine from a tank of known high quality fuel. Refer to the Owners Manual or Operation and Maintenance Manual for the engine being serviced for fuel specifications.

OK

Go To Next Step

STEP 26

Overhead adjustments are **not** correct

Measure and adjust the overhead settings. Refer to Procedure Procedure 003-004 in Section 3.

OK

Go To Next Step

STEP 27

Injector(s) are malfunctioning

Perform diagnostics to find the malfunctioning injector(s). Replace the injector(s) as necessary. Refer to Procedures Procedure 014-008 in Section 14 and Procedure 006-026 in Section 6.

OK

Go To Next Step

STEP 28

Internal engine damage

Analyze the oil and inspect the filters to locate an area of probable damage. Refer to Procedure Procedure 007-044 in Section 7.

Fuel in Coolant

This is symptom tree t091

Cause

Correction

STEP 1

Bulk coolant supply is contaminated

Check the bulk coolant supply. Drain the coolant and replace with noncontaminated coolant. Replace the coolant filters. Refer to Procedure 008-018.

OK

Go To Next Step

STEP 2

Cylinder head is cracked or porous

Pressure-test the cylinder head. Refer to Procedure 006-013 to disconnect the fuel drain connection at the rear of the cylinder head. Pressure test the cooling system and look for coolant leaks. See Procedure 008-020.

Fuel in the Lubricating Oil

This is symptom tree t092

Cause

Correction

STEP 1

Bulk oil supply is contaminated

Check the bulk oil supply. Drain the oil and replace with noncontaminated oil. Replace the oil filters. Refer to Procedures 007-037 .

OK

Go To Next Step

STEP 2

Electronic fault codes active or high counts of inactive fault codes

View and troubleshoot the fault codes with INSITE™. Refer to the corresponding Electronic Control System Troubleshooting and Repair Manual for the engine being serviced .

OK

Go To Next Step

STEP 3

Engine idle time is excessive

Low oil and coolant temperatures can be caused by long idle time (greater than 10 minutes). Shut off the engine rather than idle for long periods. If idle time is necessary, raise the idle speed. the corresponding Electronic Control System Troubleshooting and Repair Manual for the engine being serviced

OK

Go To Next Step

STEP 4

Fuel drain line restriction

Check the fuel drain lines for restriction. Refer to Procedures 006-012 .

OK

Go To Next Step

STEP 5

Injector hold-down clamp capscrews are loose

Tighten capscrews to specification. Refer to Procedure 006-026.

OK

Go To Next Step

STEP 6

Injector o-rings are damaged or missing

Remove and check the injectors. Replace the injector o-rings. Refer to Procedure 006-026.

OK

Go To Next Step

STEP 7

Injector is malfunctioning

Perform the single-cylinder cutout test. Replace the injectors as necessary. Refer to Procedure 006-026 and Procedure 014-008.

OK

Go To Next Step

STEP 8

Injector sealing washer is **not** correct

Remove the injectors and verify the injector sealing washer thickness. Refer to Procedure 006-026.

OK

Go To Next Step

Fuel in the Lubricating Oil

This is symptom tree t092

Cause

Correction

STEP 9

Cylinder head is cracked or porous

Pressure-test the cylinder head. Refer to Procedure 006-013 to disconnect the fuel drain connection at the rear of the cylinder head. Pressure test the fuel drain drilling in the cylinder head. See Procedure 002-004.

OK

Go To Next Step

STEP 10

Gear pump is malfunctioning

Check the gear pump output pressure. Replace the gear pump if necessary. Refer to Procedure 005-016.

OK

Go To Next Step

STEP 11

Internal engine damage

Analyze the oil and inspect the filters to locate an area of probable damage. Refer to Procedure 007-044.

Intake Manifold Air Temperature Above Specification

This is symptom tree t096

Cause

Correction

STEP 1

Fan drive belt is broken

Check the fan drive belt. Replace the belt, if necessary. Refer to Procedure 008-002 in Section 8.

OK

Go To Next Step

STEP 2

Fan drive belt is loose

Check the belt tension and tighten, if necessary. Refer to Procedure 008-002 in Section 8.

OK

Go To Next Step

STEP 3

Cold weather radiator cover or winterfront is closed

Open the cold weather radiator cover or the winterfront. Refer to the OEM service manual.

OK

Go To Next Step

STEP 4

Radiator shutters are **not** opening completely, or the shutterstat setting is wrong

Inspect the radiator shutters. Repair or replace, if necessary. Check the shutterstat setting. Refer to the OEM service manual.

OK

Go To Next Step

STEP 5

Charge-air cooler fins, radiator fins, or air conditioner condenser fins are damaged or obstructed with debris

Inspect the charge-air cooler, air conditioner condenser, and radiator fins. Clean, if necessary. Refer to Procedure 010-027 in Section 10.

OK

Go To Next Step

STEP 6

Electronic fault codes active or high counts of inactive fault codes

View and troubleshoot the fault codes with INSITE™ electronic service tool. Refer to the corresponding Electronic Control System Troubleshooting and Repair Manual for the engine being serviced.

OK

Go To Next Step

STEP 7

Intake manifold air temperature sensor has an in-range malfunction

Check the intake manifold air temperature sensors that correspond to the fault code. Replace the sensor, if necessary. Refer to Procedure 019-159 in Section 19 of the corresponding Electronic Control System Troubleshooting and Repair Manual for the engine being serviced, to monitor and check the manifold temperature sensor.

OK

Go To Next Step

Intake Manifold Air Temperature Above Specification

This is symptom tree t096

Cause

Correction

<p>STEP 8 Programmable parameters or selected features are not correct</p>	<p>Check the programmable parameters and the selected features with an electronic service tool. Set the parameters and features again, if necessary. Refer to Procedure 019-078 in Section 19 in the Electronic Control System Troubleshooting and Repair Manual for the engine being serviced.</p>
<p>OK Go To Next Step</p>	
<p>STEP 9 Fan drive or fan controls are malfunctioning</p>	<p>Check the fan drive and controls. Refer to Procedure 008-027 in Section 8 if electronically controlled by the engines' ECM. If OEM controlled, see OEM service manual.</p>
<p>OK Go To Next Step</p>	
<p>STEP 10 Fan is not correct</p>	<p>Check the fan part number and compare it to the OEM-specified part number. Replace the fan, if necessary. Refer to the OEM service manual.</p>
<p>OK Go To Next Step</p>	
<p>STEP 11 Fan shroud is damaged or missing or the air recirculation baffles are damaged or missing</p>	<p>Inspect the shroud and the recirculation baffles. Repair, replace, or install, as necessary. Refer to Procedure 008-038 in Section 8.</p>
<p>OK Go To Next Step</p>	
<p>STEP 12 Vehicle speed is too low for adequate cooling with high engine load</p>	<p>Reduce the engine load. Increase the engine (fan) rpm by downshifting.</p>
<p>OK Go To Next Step</p>	
<p>STEP 13 Exhaust system leaking hot air into engine compartment</p>	<p>Check the exhaust plumbing for leaks or broken components. Refer to Procedure 010-024 in Section 10.</p>
<p>OK Go To Next Step</p>	
<p>STEP 14 Incorrect/Excessive exhaust brake operation</p>	<p>If applicable, check the exhaust brake operation and cooling fan operation. Refer to Procedure 020-016 in Section 20 and/or the manufacturers instructions</p>
<p>OK Go To Next Step</p>	

Intake Manifold Air Temperature Above Specification

This is symptom tree t096

Cause

Correction

STEP 15
Malfunctioning intake air heater

Connect INSITE™ electronic service tool. From the list of "ECM Diagnostic Tests", select "Grid Heater Override". Follow the instructions on the screen to determine if the cold starting aid is working properly. If the intake air heater is **not** functioning properly, troubleshoot the intake air heater wiring and relay circuits. Refer to Procedure 019-408 in Section 19.

OK
Go To Next Step

STEP 16
Intake manifold pressure (boost) sensor or circuit is malfunctioning

Check the boost sensor and circuit. Compare the intake manifold pressure sensor reading in the monitor mode. Use INSITE™ electronic service tool to compare to a manual pressure gauge. Refer to Procedure 019-159 in Section 19 in the corresponding Electronic Control System Troubleshooting and Repair Manual for the engine being serviced.

OK
Go To Next Step

STEP 17
Vehicle cooling system is **not** adequate

Verify that the engine and vehicle cooling systems are using the correct components. Refer to the OEM service manual.

OK
Go To Next Step

STEP 18
Fan is **not** an adequate size for the application

Verify that the fan is the correct size. Refer to the OEM service manual.

Intake Manifold Pressure (Boost) is Below Normal

This is symptom tree t097

Cause	Correction
<p>STEP 1 Air intake or exhaust leaks</p>	<p>Inspect the air intake and exhaust systems for air leaks. Refer to Procedure 010-024 in Section 10.</p>
<p>OK Go To Next Step</p>	
<p>STEP 2 Air intake system restriction is above specification</p>	<p>Check the air intake system for restrictions. Clean or replace the air filter and inlet piping as necessary. Refer to Procedure 010-031 in Section 10.</p>
<p>OK Go To Next Step</p>	
<p>STEP 3 Charge-air cooler is restricted or leaking</p>	<p>Inspect the charge-air cooler for air restrictions or leaks. Refer to Procedure 010-027 in Section 10.</p>
<p>OK Go To Next Step</p>	
<p>STEP 4 Electronic fault codes active or high counts of inactive fault codes</p>	<p>Refer to Section TF in the Troubleshooting and Repair Manual, Electronic Control Systems, ISB (4 cylinder) and ISB^e (4 and 6 cylinder) Series Engines, Bulletin 3666477, for fault code troubleshooting.</p>
<p>OK Go To Next Step</p>	
<p>STEP 5 Intake manifold pressure sensor is malfunctioning</p>	<p>Check the intake manifold pressure sensor. Refer to Procedure 019-159 in Section 19 in the Troubleshooting and Repair Manual, Electronic Control System, ISB (4 cylinder) and ISB^e (4 and 6 cylinder) Series Engines, Bulletin 3666477.</p>
<p>OK Go To Next Step</p>	
<p>STEP 6 Air compressor connection is loose or damaged</p>	<p>Check the connection between the manifold and the air compressor. Repair or replace if necessary.</p>
<p>OK Go To Next Step</p>	
<p>STEP 7 Exhaust system restriction is not within specification</p>	<p>Check the exhaust system for restrictions. Refer to Procedure 011-009 in Section 11.</p>
<p>OK Go To Next Step</p>	
<p>STEP 8 Turbocharger wastegate is damaged or is stuck open</p>	<p>Check the wastegate for freedom of movement. Inspect the wastegate for damage. Refer to Procedure 010-050 in Section 10.</p>
<p>OK Go To Next Step</p>	

Intake Manifold Pressure (Boost) is Below Normal

This is symptom tree t097

Cause

Correction

STEP 9

Turbocharger is **not** correct

Check the turbocharger part number and compare it to the Control Parts List (CPL), Bulletin 4021328. Replace the turbocharger, if necessary. Refer to Procedure 010-033 in Section 10.

OK

Go To Next Step

STEP 10

Turbocharger is worn or damaged

Check the turbocharger for damage. Measure the turbine and compressor wheel clearances. Refer to Procedure 010-033 in Section 10.

OK

Go To Next Step

STEP 11

Engine power output is low

Refer to the Engine Power Output Low troubleshooting symptom tree in Section TS.

Lubricating Oil Consumption Excessive

This is symptom tree t102

Cause

Correction

STEP 1

Verify the oil consumption rate

Check the amount of oil added versus the mileage. Refer to the Oil Consumption Report form in the Troubleshooting Overview of Section TS. Verify if the oil consumption rate is within Cummins Inc. "acceptable oil usage" as defined in the table..

OK

Go To Next Step

STEP 2

Lubricating oil leak (external)

Inspect the engine for external oil leaks Use Black Light Kit, Part Number 3163337, and fluorescent tracer, Part Number 3376891, to help identify the leak. Follow the corresponding instructions. Repair as necessary.

OK

Go To Next Step

STEP 3

Crankcase ventilation system is plugged

Check and clean the crankcase breather and vent tube. Refer to Procedure 003-018 and Procedure 003-002 in Section 3.

OK

Go To Next Step

STEP 4

Lubricating oil does **not** meet specifications for operating conditions

Change the oil and filters. Refer to Procedure 007-037 in Section 7 and the lubricating oil recommendations and specifications procedure in the appropriate Operation and Maintenance manual. For ISB and ISBe engines, use the following procedure in the ISBe and ISB (Common Rail Fuel System) Series Engines Operation and Maintenance Manual, Bulletin 3666496. Refer to Procedure 018-003 in Section V. For QSB4.5 and QSB6.7 engines, use the following procedure in the QSB4.5 and QSB6.7 Engines Operation and Maintenance Manual, Bulletin 4021531. Refer to Procedure 018-003 in Section V.

OK

Go To Next Step

STEP 5

Lubricating oil drain interval is excessive

Verify the correct lubricating oil drain interval. Refer to the maintenance schedule in the appropriate Operation and Maintenance manual. For ISB and ISBe engines, use the following procedure in the ISBe and ISB (Common Rail Fuel System) Series Engines Operation and Maintenance Manual, Bulletin 3666496. Refer to Procedure 102-002 in Section 2. For QSB4.5 and QSB6.7 engines, use the following procedure in the QSB4.5 and QSB6.7 Engines Operation and Maintenance Manual, Bulletin 4021531. Refer to Procedure 102-002 in Section 2.

OK

Go To Next Step

Lubricating Oil Consumption Excessive

This is symptom tree t102

Cause

STEP 6

Air compressor is pumping lubricating oil into the air system

OK

Go To Next Step

STEP 7

Lubricating oil cooler is leaking

OK

Go To Next Step

STEP 8

Lubricating oil level is above specification

OK

Go To Next Step

STEP 9

Engine angularity during operation exceeds specification

OK

Go To Next Step

STEP 10

Turbocharger oil seal is leaking

OK

Go To Next Step

STEP 11

Piston rings are **not** seated correctly (after an engine rebuild or piston installation)

OK

Go To Next Step

STEP 12

Lubricating oil is contaminated with coolant or fuel

OK

Go To Next Step

STEP 13

Valve stem clearance is excessive or the valve stem seals are damaged

OK

Go To Next Step

Correction

Check the air lines for carbon buildup and lubricating oil. Refer to Procedure 012-003 in Section 12. If oil is found, see the Air Compressor Pumping Excess Lubricating Oil into the Air System troubleshooting tree .

Check the lubricating oil cooler for coolant leaks. Refer to the Coolant loss Internal troubleshooting symptom tree if oil is found.

Check the oil level. Verify the dipstick calibration and oil pan capacity. Fill the system to the specified level. Refer to Procedure 007-009 in Section 7.

Refer to the Engine Specification Data Sheet for angularity specifications for the engine being serviced. For marine applications, see Recreational Installation directions for Marine Engines, Bulletin 3884649.

Check the turbocharger compressor and turbine seals. Refer to Procedure 010-033 in Section 10.

Check blowby. Refer to Section 14. If blowby is excessive, check the piston rings for correct seating. Refer to Procedure 001-043 and Procedure 001-047 in Section 1.

Refer to the Lubricating Oil Contaminated troubleshooting symptom tree.

Check the valve stems and seals. Refer to Procedure 002-004 in Section 2.

Lubricating Oil Consumption Excessive

This is symptom tree t102

Cause

Correction

STEP 14

Cylinder head valve guides are excessively worn

Check the valve guides for wear. Replace the cylinder head, if necessary. Refer to Procedure 002-004 in Section 2.

OK

Go To Next Step

STEP 15

Piston or piston rings are worn or damaged

Check for air intake system leaks. Check the pistons and piston rings for wear or damage. Refer to Procedure 010-047 and Procedure 010-024 in Section 10. Analyze the lubricating oil and oil filters to locate an area of probable damage and cause. Refer to Procedure 007-044 and Procedure 007-083 in Section 7.

OK

Go To Next Step

STEP 16

Internal engine damage

Analyze the oil and inspect the filters to locate an area of probable damage. Refer to Procedure 007-044 and Procedure 007-083 in Section 7.

Lubricating Oil Contaminated

This is symptom tree t103

Cause

Correction

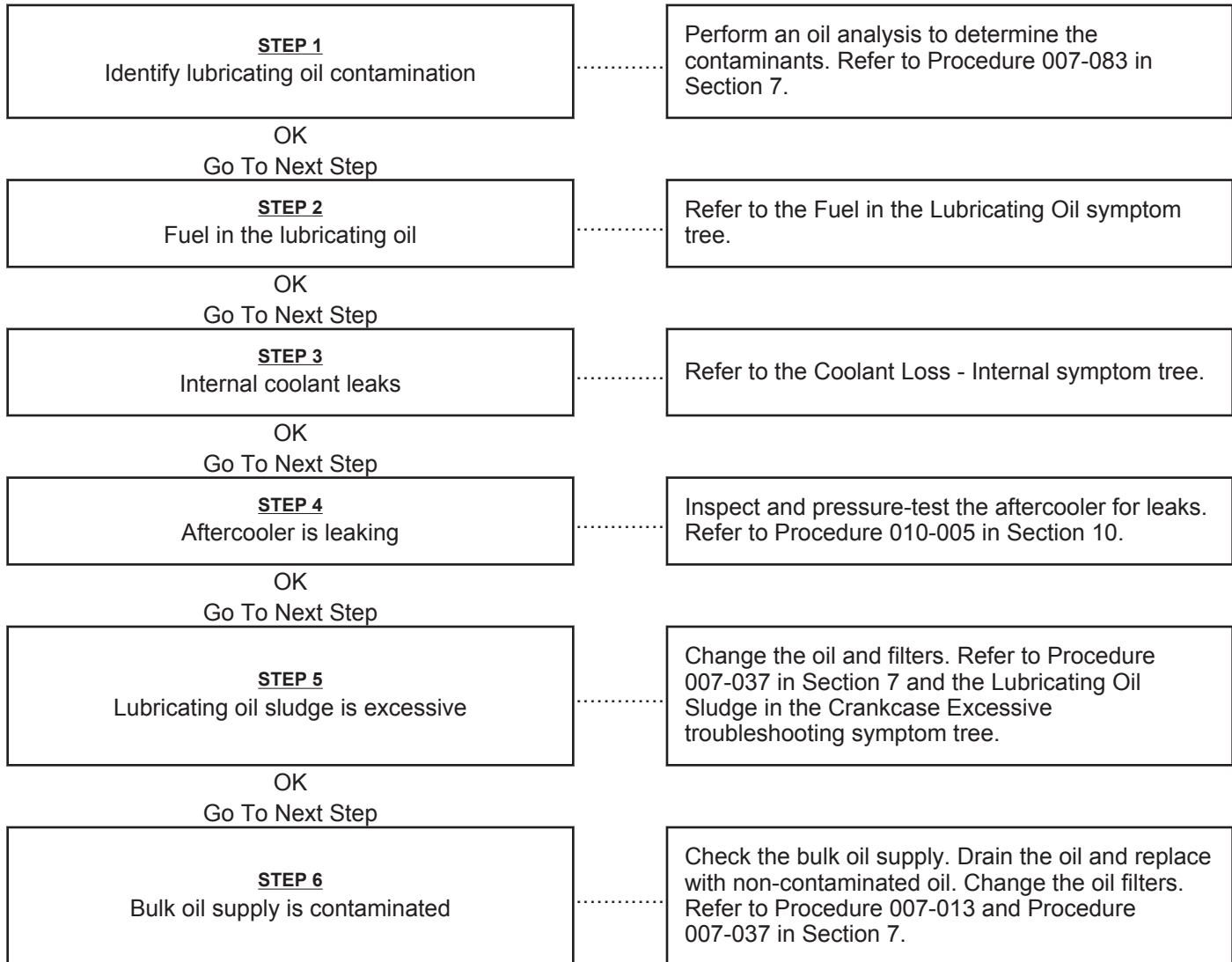

Lubricating Oil Pressure High

This is symptom tree t104

Cause

STEP 1

Electronic fault codes active or high counts of inactive fault codes

OK

Go To Next Step

STEP 2

Coolant temperature is below specification

OK

Go To Next Step

STEP 3

Lubricating oil does **not** meet specifications for operating conditions

OK

Go To Next Step

STEP 4

OEM installed lubricating oil pressure switch, gauge, or sensor is malfunctioning or is not in correct location

OK

Go To Next Step

STEP 5

Engine installed lubricating oil pressure sensor/switch or circuit is malfunctioning (electronic controlled fuel system)

OK

Go To Next Step

STEP 6

Lubricating oil filter plumbing **not** routed correctly

OK

Go To Next Step

Correction

View and troubleshoot the fault codes with INSITE™ electronic service tool. Refer to the corresponding Electronic Control System Troubleshooting and Repair Manual for the engine being serviced..

Refer to the Coolant Temperature is Below Normal troubleshooting symptom tree.

Change the oil and filters. Refer to Procedure 007-037 in Section 7. See the corresponding Owners Manual or Operation and Maintenance Manual for the engine being serviced for oil specifications.

Measure the lubricating oil pressure. Refer to Procedure 007-029 in Section 7. Operate the engine and compare readings to the vehicles OEM gauge or oil pressure sensor/switch. See the OEM service manual.

Measure the lubricating oil pressure. Refer to Procedure 007-029 in Section 7. If equipped with an oil pressure sensor, monitor the oil pressure with INSITE® service tool. Operate the engine and compare readings. If necessary, replace the oil pressure sensor /switch. Refer to Procedure 019-155 in Section 19, in the corresponding Owners Manual or Operation and Maintenance Manual for the engine being serviced.

Verify the routing of the lubricating filter plumbing is correct. Refer to Procedure Procedure 007-092 in Section 7.

Lubricating Oil Pressure High

This is symptom tree t104

Cause

Correction

STEP 7

Incorrect lubricating oil pump installed

Check if the correct lubricating oil pump part number is installed. Refer to Procedure 007-031 in Section 7 (for example a 6 cylinder oil pump used in a 4 cylinder engine) See the appropriate parts manual and/or the QuickServe® Online Internet Website. If necessary replace the oil pump

OK

Go To Next Step

STEP 8

Main oil pressure regulator is malfunctioning

Replace the main oil pressure regulator assembly. Refer to Procedure 007-029 in Section 7.

Lubricating Oil Pressure Low

This is symptom tree t105

Cause

STEP 1

Electronic fault codes active or high counts of inactive fault codes

OK

Go To Next Step

STEP 2

OEM installed lubricating oil pressure switch, gauge or sensor is malfunctioning or is not in correct location

OK

Go To Next Step

STEP 3

Engine installed lubricating oil pressure sensor/switch or circuit is malfunctioning (electronic controlled fuel system)

OK

Go To Next Step

STEP 4

Lubricating oil level is above or below specification

OK

Go To Next Step

STEP 5

Lubricating oil leak (external)

OK

Go To Next Step

STEP 6

Lubricating oil does **not** meet specifications for operating conditions

OK

Go To Next Step

STEP 7

Lubricating oil is contaminated with coolant or fuel

OK

Go To Next Step

Correction

View and troubleshoot the fault codes with INSITE™. Refer to the corresponding Electronic Control System Troubleshooting and Repair Manual for the engine being serviced.

Measure the lubricating oil pressure. Refer to Procedure 007-037 Operate the engine and compare readings to the vehicles OEM installed gauge. See the OEM service manual.

Measure the lubricating oil pressure. Refer to Procedure 007-037 If equipped with an oil pressure sensor, monitor the oil pressure with INSITE™. Operate the engine and compare readings . If necessary, replace the oil pressure/ sensor switch. See Procedure 019-155 in the corresponding Electronic Control System troubleshooting and Repair Manual for the engine being serviced.

Check the oil level. Add or drain oil, if necessary. Refer to Procedures 007-037 and 007-009.

Inspect the engine for external oil leaks. Tighten the capscrews, pipe plugs, and fittings. Replace gaskets, if necessary. Refer to the Black Light Kit, part number 3163337 and fluorescent tracer, part number 3376891 to help identify the leak. Follow the corresponding instructions. Repair as necessary.

Change the oil and filters. Refer to Procedures 007-037. See the corresponding Owners Manual or Operation and Maintenance Manual for the engine being serviced for oil specifications.

Refer to the Lubricating Oil Contaminated symptom tree .

Lubricating Oil Pressure Low

This is symptom tree t105

Cause

Correction

STEP 8

Engine angularity during operation exceeds specification

Refer to the engine specification data sheets for angularity specifications for the engine being serviced. For marine engines see bulletin 3884649.

OK

Go To Next Step

STEP 9

Coolant temperature is above specification

Refer to the Coolant specification Temperature above normal — Gradual Overheat symptom tree .

OK

Go To Next Step

STEP 10

Lubricating oil filter plumbing **not** routed correctly

Verify the routing of the lubricating filter plumbing is correct. Refer to Procedure 007-092.

OK

Go To Next Step

STEP 11

Main oil pressure regulator is malfunctioning

Check the main oil pressure regulator assembly. Refer to Procedure 007-029.

OK

Go To Next Step

STEP 12

Lubricating oil suction or transfer tube is loose or broken, or the gasket or o-rings are leaking

Remove and inspect the oil pan or suction tube. Refer to Procedure 007-025.

OK

Go To Next Step

STEP 13

Engine installed lubricating oil pressure sensor / switch or circuit is blocked

Check if sealant is blocking the oil pressure sensor / switch port by removing the front gear cover. Refer to Procedure 007-031 Check if the gear cover has been removed/installed recently on an engine equipped with the oil pressure switch/ sensor in the front gear cover.

OK

Go To Next Step

STEP 14

Lubricating oil pump is malfunctioning

Inspect the lubricating oil pump. Refer to Procedure 007-031.

OK

Go To Next Step

STEP 15

Incorrect lubricating oil cooler installed

Check if the correct lubricating oil cooler part number is installed. Refer to Procedure 007-031 (For example a four cylinder pump in a six cylinder engine). See the appropriate parts manual and /or the QuickServe® Online Internet Website. If necessary replace the oil pump.

OK

Go To Next Step

Lubricating Oil Pressure Low

This is symptom tree t105

Cause

Correction

STEP 16

Lubricating oil cooler is plugged

Check the oil cooler. Refer to Procedure 007-003.

OK

Go To Next Step

STEP 17

Lubricating oil temperature is above specification

Refer to the Lubricating Oil Temperature Above Specification symptom tree .

OK

Go To Next Step

STEP 18

Piston cooling nozzles are damaged or are **not** installed correctly

Check the piston cooling nozzles for damage and correct installation. Refer to Procedure 001-046.

OK

Go To Next Step

STEP 19

Internal engine damage or internal lubricating oil leak

Analyze the lubricating oil. Inspect the oil filter. Refer to Procedure 007-044 to locate an area of probable damage. Places for probable damage include internal cup plugs, main bearings, rod bearings, cam bushings and rocker levers.

Lubricating Oil Sludge in the Crankcase Excessive

This is symptom tree t106

Cause

Correction

STEP 1

Bulk oil supply is contaminated

Check the bulk oil supply. Drain the oil and replace with noncontaminated oil. Replace the oil filters. Refer to Procedures 007-037 .

OK

Go To Next Step

STEP 2

Lubricating oil does **not** meet specifications for operating conditions

Change the oil and filters. Refer to Procedure 007-037. See the corresponding Owners Manual or Operation and Maintenance Manual to the engine being serviced for oil specifications.

OK

Go To Next Step

STEP 3

Lubricating oil drain interval is excessive

Verify the correct lubricating oil drain interval. Refer to OEM Owners or Operation and Maintenance Manual for the engine that is being serviced.

OK

Go To Next Step

STEP 4

Fuel grade is **not** correct for the application or the fuel quality is poor

Operate the engine from a tank of high-quality fuel. Refer to OEM Owners Manual or Operation and Maintenance Manual corresponding to the engine being serviced for fuel specifications. .

OK

Go To Next Step

STEP 5

Coolant temperature is below specification

Refer to the Coolant Temperature is Below Normal symptom tree .

OK

Go To Next Step

STEP 6

Lubricating oil is contaminated with coolant or fuel

Refer to the Lubricating Oil Contaminated symptom tree .

OK

Go To Next Step

STEP 7

Lubricating oil temperature is above specification

Refer to Procedure 007-003 if it is necessary to replace the lubricating oil cooler. Check if the correct lubricating oil cooler part number is installed. See the appropriate parts manual and / or the Quickserve® Online Internet Website..

OK

Go To Next Step

STEP 8

Crankcase pressure is excessive

Check for excessive blowby. Refer to Procedure 014-010.

OK

Go To Next Step

Lubricating Oil Sludge in the Crankcase Excessive

This is symptom tree t106

Cause

STEP 9

Exhaust system restriction is above or below specification

Correction

Check the exhaust system for restriction. Refer to Procedure 011-009.

Lubricating Oil Temperature Above Specification

This is symptom tree t107

Cause

STEP 1

Electronic fault codes active or high counts of inactive fault codes

OK

Go To Next Step

STEP 2

Coolant temperature is above specification

OK

Go To Next Step

STEP 3

Lubricating oil level is above or below specification

OK

Go To Next Step

STEP 4

Lubricating oil temperature switch, gauge, or sensor malfunctioning or **not** in the correct location

OK

Go To Next Step

STEP 5

OEM components cooled with engine lubricating oil are malfunctioning

OK

Go To Next Step

STEP 6

Lubricating oil cooler is plugged

OK

Go To Next Step

STEP 7

Incorrect lubricating oil cooler installed

OK

Go To Next Step

STEP 8

Internal engine damage

Correction

View and troubleshoot the fault codes with INSITE™. Refer to the corresponding Electronic Control System Troubleshooting and Repair Manual for the engine being serviced..

Refer to the Coolant Temperature Above Normal — gradual overheat symptom tree.

Check the oil level. Add or drain oil, if necessary. Refer to Procedures 007-037 and 007-009.

Check the oil temperature switch, gauge, or sensor for correct operation and location. Refer to the OEM service manual.

Check OEM components. Refer to the OEM service manual.

Check the oil cooler. Refer to Procedure 007-003. Check if the correct lubricating oil cooler part number is installed. See the appropriate parts number manual and the Quickserve® Online Internet Website. If necessary replace the oil cooler.

Check if the correct lubricating oil cooler part number is installed. Refer to Procedure 007-003

Analyze the oil and inspect the filters to locate an area of probable damage. Refer to Procedure 007-083 and Procedure 007-044.

Lubricating or Transmission Oil in the Coolant

This is symptom tree t108

Cause	Correction
<p>STEP 1 Bulk coolant supply is contaminated</p>	<p>Check the bulk coolant supply. Drain the coolant and replace with non-contaminated coolant. Replace the coolant filters. Refer to Procedure 008-018 in Section 8.</p>
<p>OK Go To Next Step</p>	
<p>STEP 2 Lubricating oil cooler is malfunctioning</p>	<p>Check the oil cooler. Refer to Procedure 007-003 in Section 7.</p>
<p>OK Go To Next Step</p>	
<p>STEP 3 Torque converter cooler or hydraulic oil cooler is malfunctioning</p>	<p>Remove and inspect the cooler cores and o-rings. Refer to the OEM service manual.</p>
<p>OK Go To Next Step</p>	
<p>STEP 4 Turbocharger bearing housing is cracked or porous (if equipped with liquid cooled turbocharger bearing housing)</p>	<p>Check turbocharger bearing housing. Refer to Procedure 010-033 in Section 10.</p>
<p>OK Go To Next Step</p>	
<p>STEP 5 Marine gear oil cooler is malfunctioning</p>	<p>Remove and inspect the marine gear oil cooler. Refer to Procedure 008-041 in Section 8.</p>
<p>OK Go To Next Step</p>	
<p>STEP 6 Cylinder head gasket is leaking</p>	<p>Remove the cylinder head and check the cylinder head gasket. Refer to Procedure 002-004 in Section 2.</p>
<p>OK Go To Next Step</p>	
<p>STEP 7 Cylinder head is cracked or porous</p>	<p>Pressure test the cylinder head. Refer to Procedure 002-004 in Section 2.</p>
<p>OK Go To Next Step</p>	
<p>STEP 8 Cylinder block is cracked or porous</p>	<p>Replace the cylinder block. Refer to Procedure 001-026 in Section 1.</p>

Turbocharger Leaks Engine Oil or Fuel

This is symptom tree t122

Cause	Correction
<p>STEP 1 Engine is operating for extended periods under light- or no-load conditions (slobbering)</p>	<p>Review the engine operating instructions in Section 1 of the Operation and Maintenance Manual, or the corresponding Owners Manual. Low oil and coolant temperatures can be caused by long idle time (greater than ten minutes). Shut off the engine rather than idle for long periods. If idle time is necessary, raise the engine /idle speed. Review the operating instructions in the relevant manuals. .</p>
<p>OK Go To Next Step</p>	
<p>STEP 2 White smoke is present</p>	<p>Refer to the Engine Performance symptom tree.</p>
<p>OK Go To Next Step</p>	
<p>STEP 3 Lubricating oil lines leak oil</p>	<p>Check all oil lines and fittings for leaks. Tighten loose fittings and replace leaking oil lines if necessary.</p>
<p>OK Go To Next Step</p>	
<p>STEP 4 Turbocharger oil drain line is restricted</p>	<p>Remove the turbocharger oil drain line and check for restriction. Clean or replace the oil drain line. Refer to Procedure 010-045.</p>
<p>OK Go To Next Step</p>	
<p>STEP 5 Crankcase ventilation system is plugged</p>	<p>Check and clean the crankcase breather and vent tube. Refer to Procedure 003-002 or 003-018.</p>
<p>OK Go To Next Step</p>	
<p>STEP 6 Lubricating oil or fuel is entering the turbocharger</p>	<p>Remove the intake and exhaust piping, and check for oil or fuel.</p>
<p>OK Go To Next Step</p>	
<p>STEP 7 Air intake system restriction is above specification</p>	<p>Check the air intake system for restriction. Clean or replace the air filter and inlet piping as necessary. Refer to Procedure 010-031.</p>
<p>OK Go To Next Step</p>	
<p>STEP 8 Exhaust system restriction is not within specification</p>	<p>Check the exhaust system for restrictions. Refer to Procedure 011-009.</p>
<p>OK Go To Next Step</p>	

Turbocharger Leaks Engine Oil or Fuel

This is symptom tree t122

Cause

Correction

STEP 9

Turbocharger oil seal is leaking

Check the turbocharger compressor and turbine seals. Refer to Procedures 010-033.

OK

Go To Next Step

STEP 10

Turbocharger wheel clearance is out of specification

Check the radial bearing clearance and axial clearance. Inspect the turbocharger. Repair or replace the turbocharger if necessary. Refer to Procedure 010-033.

OK

Go To Next Step

STEP 11

Valve stem clearance is excessive or the valve stem seals are damaged

Check the valve stems and seals. Refer to Procedures 002-004.

Diesel Exhaust Fluid Usage - Abnormal

This is symptom tree t128

Cause

Correction

STEP 1

Electronic fault codes active or high counts of inactive fault codes

Refer to Section TF in Troubleshooting and Repair Manual, ISB, ISBe4, QSB4.5, QSB5.9, QSB6.7, ISC, QSC8.3, ISL, ISLe3, and QSL9 Engines, CM850 Electronic Control System, Bulletin 4021416.

OK

Go To Next Step

STEP 2

Urea tank empty or incorrect fluid

Verify urea is in the reservoir tank. Fill the tank with urea, if empty. Refer to the progressive damage limits, if fuel, oil, or coolant, were found in the reservoir tank.

OK

Go To Next Step

STEP 3

Urea leak (external)

Inspect for external urea leaks or crystallization at exhaust joints, tailpipe exit, aftertreatment nozzle, or associated plumbing. Repair as necessary. Refer to Procedure Procedure 011-036, Exhaust Catalyst. Procedure 011-040, Aftertreatment Nozzle.

OK

Go To Next Step

STEP 4

Extended operation of the engine in low-duty cycle, extended idling, and/or low ambient temperatures can result in reduced urea usage. Conversely, extended operation of the engine in high-duty cycle and/or high ambient temperatures can result in increased urea usage

Perform Urea Doser Pump Override Test with INSITE™ electronic service tool. Refer to Procedure 019-440 in Troubleshooting and Repair Manual, ISB, ISBe4, QSB4.5, QSB5.9, QSB6.7, ISC, QSC8.3, ISL, ISLe3, and QSL9 Engines, CM850 Electronic Control System, Bulletin 4021416.

OK

Go To Next Step

STEP 5

Urea leak (internal)

Inspect for internal urea leaks or crystallization between the aftertreatment nozzle and the exhaust catalyst. Repair as necessary. Refer to Procedure Procedure 011-036, Exhaust Catalyst. Procedure 011-040, Aftertreatment Nozzle.

Engine Noise Excessive - Drive Belt

This is symptom tree t170

Cause

Correction

STEP 1

Verify which belt drive is producing noise

If the application uses an accessory belt drive, it is important to verify which belt is making noise. If the noise disappears when the accessory drive belt is removed, the source of the issue is the accessory drive. If it does not change, the source of the noise is the primary drive belt. Continue troubleshooting the drive that is making noise. Refer to Procedure 008-002 in Section 8.

OK

Go To Next Step

STEP 2

Determine the type of belt noise

There are two types of belt noise: chirping and squealing. A chirping noise is a symptom of misalignment in the system. A squeal noise is a symptom of loss of tension in the system. Use a spray bottle of water to spray the groove side of the belt on the drive producing the noise. If the noise goes away, it is likely a belt chirp. If the noise did not change when water was sprayed on the groove side, spray the flat side of the belt. If the noise continues, or gets worse, it is likely a belt squeal.

OK

Go To Next Step

STEP 3

Determine the engine operating conditions that produce noise

Interview the driver to determine if the noise is continuous. If the noise is not continuous, determine the conditions when the noise is heard. Unique operating conditions could be the root cause of the belt noise.

OK

Go To Next Step

STEP 4

Isolate the source of the drive belt noise

Use a stethoscope, or equivalent device, to find the source of the noise. Refer to Procedure 008-002 in Section 8. Once the location of the noise has been identified, work in a direction opposite to belt travel (**counterclockwise**, for example) at the pulley where the noise originates and work upstream to determine which pulley is causing the noise.

OK

Go To Next Step

STEP 5

Drive belt incorrect, not routed correctly, or damaged

Verify the proper belt part number is installed on the drive producing the noise. Verify the belt tensioner arm stops are in the proper orientation with the drive belt installed. Inspect the belt for cracks, glazing, tears, cuts, and excessive wear. Inspect the belt grooves for debris, uneven or excessive rib wear, and exposed belt cords. Refer to Procedure 008-002 in Section 8 or the OEM service manual.

OK

Go To Next Step

Engine Noise Excessive - Drive Belt

This is symptom tree t170

Cause

Correction

STEP 6
Loss of belt tension

For a fan drive belt, with the belt installed, verify that neither tensioner arm stop is in contact, or within 9.5 mm [3/8 in], of the spring case stop. If either of the stops are touching or within the specified range, replace the belt. Refer to Procedure 008-002 in Section 8. After replacing the belt, if the tensioner arm stops are still in contact, or within 9.5 mm [3/8 in] of the spring case stop, the tensioner **must** be replaced. Refer to Procedure 008-087 in Section 8. With the belt installed, pivot the belt tensioner away from the belt **counterclockwise** to check for smooth operation. For the accessory drive belt, verify the correct tension is applied. Refer to the OEM service manual.

OK
Go To Next Step

STEP 7
Belt tensioner is inoperative

With the belt removed, verify the belt tensioner pulley bearing on the drive producing noise is functioning properly. Also verify the belt tensioner moves smoothly throughout its travel. Reference the following procedure. Refer to Procedure 008-087 in Section 8.

OK
Go To Next Step

STEP 8
Accessory drive components incorrect or inoperative

Verify all accessory drive components and pulleys are correct. Refer to Procedure 008-002 in Section 8. Rotate all pulleys on the drive which are causing noise to make sure of smooth operation and bearing functionality.

OK
Go To Next Step

STEP 9
Accessory pulley is out of alignment

Verify the drive system pulley alignment with the belt alignment laser tool, Part Number 3163524, or equivalent. Refer to Procedure 008-002 in Section 8.

Section TT - Troubleshooting Symptoms (New Format)

Section Contents

	Page
Engine Performance Troubleshooting Tree - ISB Engines Equipped with EGR (CM850 Electronic Control System)	TT-82
Engine Performance Troubleshooting Tree - ISB, ISBe, and QSB engines without EGR (CM800 and CM850 Electronic Control System)	TT-1
Engine Performance Troubleshooting Tree for QSB5.9 Marine Engines with CM850 Electronic Control System	TT-49
Vibration Excessive	TT-141

This Page Left Intentionally Blank

Engine Performance Troubleshooting Tree - ISB, ISBe, and QSB engines without EGR (CM800 and CM850 Electronic Control System)

This troubleshooting procedure should be followed for the following symptoms:

- Engine Acceleration or Response Poor
- Engine Difficult to Start or Will **Not** Start (Exhaust Smoke)
- Engine Difficult to Start or Will **Not** Start (No Exhaust Smoke)
- Engine Power Output Low
- Engine Runs Rough at Idle
- Engine Runs Rough or Misfires
- Engine Speed Surges at Low or High Idle
- Engine Speed Surges Under Load or in Operating Range
- Smoke, Black - Excessive
- Smoke, White - Excessive
- Engine Shuts Off or Dies Unexpectedly or Dies During Deceleration
- Engine Decelerates Slowly
- Engine Starts but Will **Not** Keep Running
- Engine Will **Not** Reach Rated Speed (RPM)
- Intake Manifold Pressure (Boost) is Below Normal
- Engine Vibration Excessive

How to Use This Troubleshooting Procedure:

This symptom tree can be used to troubleshoot all performance-based symptoms listed above. Start by performing Step 1 troubleshooting. Step 2 will ask a series of questions and will provide a list of troubleshooting steps to perform, depending on the symptom.

Many steps will reference using INSITE™ electronic service tool to check for fault codes, perform tests, monitor data, and check features and parameters. It is recommended that INSITE™ electronic service tool remain connected while using this troubleshooting tree, to periodically check for fault codes. If any fault codes become active during use of the troubleshooting tree, discontinue using this troubleshooting tree and troubleshoot the active fault code.

This symptom tree often references other procedures and symptom trees. The procedures and symptom trees referenced may **not** be located in the same service literature as this symptom tree. Use the following procedure for a listing of the service literature available for the engine being serviced. Refer to Procedure 205-001 in Section L.

Shop Talk:

Driveability is a term that in general describes vehicle performance on the road. Driveability problems for an engine can be caused by several different factors. Some of the factors are engine-related and some are **not**. Before troubleshooting, it is important to determine the exact complaint and whether the engine has a real driveability problem or if it simply does **not** meet driver expectations.

Low power is a term that is used in the field to describe many different performance problems. Low power is defined as the inability of the engine to produce the power necessary to move the vehicle at a speed that can be reasonably expected under the given conditions of load, grade, wind, and so on. With industrial equipment, low power might relate to the inability of the equipment to pick up or maintain load.

Poor acceleration or response is described as the inability of the vehicle to accelerate satisfactorily from a stop or from the bottom of a grade. It can also be the lag in acceleration during an attempt to pass or overtake another vehicle at conditions less than rated speed and load. Poor acceleration or response is difficult to troubleshoot, since it can be caused by several factors.

TROUBLESHOOTING SUMMARY

STEPS	SPECIFICATIONS	SRT CODE
STEP 1: Perform basic troubleshooting procedures.		
STEP 1A: Check for active fault codes or high counts of inactive fault codes.	Active fault codes or high counts of inactive fault codes?	
STEP 1B: Perform basic troubleshooting checks.	All steps have been verified to be correct?	
STEP 2: Determination of engine symptom.		
STEP 2A: Engine Difficult to Start or Will Not Start (With or Without Exhaust Smoke), Engine Shuts Off or Dies Unexpectedly or Dies During Deceleration, or Engine Starts but Will Not Keep Running.	Is the engine symptom Engine Difficult to Start or Will Not Start (With or Without Exhaust Smoke), Engine Shuts Off or Dies Unexpectedly or Dies During Deceleration, or Engine Starts but Will Not Keep Running?	
STEP 2B: Engine Runs Rough at Idle, Engine Runs Rough or Misfires, Engine Speed Surges at Low or High Idle, Engine Speed Surges under Load or in Operating Range.	Is the engine symptom Engine Runs Rough at Idle, Engine Runs Rough or Misfires, Engine Speed Surges at Low or High Idle, Engine Speed Surges under Load or in Operating Range?	
STEP 2C: Smoke, Black - Excessive.	Is the engine symptom Smoke, Black - Excessive?	
STEP 2D: Smoke, White - Excessive.	Is the engine symptom Smoke, White - Excessive?	
STEP 2D-1: Smoke, White - Excessive.	Is the engine using coolant?	
STEP 2D-2: Smoke, White - Excessive.	Is the white smoke excessive complaint only occurring when the engine is cold and during cold ambient conditions?	
STEP 2E: Engine Acceleration or Response Poor, Engine Power Output Low, Engine Decelerates Slowly, Intake Manifold Pressure (Boost) is Below Normal or Engine Will Not Reach Rated Speed (RPM).	Is the engine symptom - Engine Acceleration or Response Poor, Engine Power Output Low, Engine Decelerates Slowly, Intake Manifold Pressure (Boost) is Below Normal or Engine Will Not Reach Rated Speed (RPM)?	
STEP 2F: Engine vibration is excessive.	Is the engine symptom - Engine Vibration Excessive?	
STEP 3: Engine will not start or stalls troubleshooting procedures.		
STEP 3A: Verify the operation of cold weather starting aids.	Are the necessary cold weather starting aids being used and are they operational as required?	
STEP 3B: Check electronic features and programmable parameters.	Are electronic features and programmable parameters the cause for the engine shutting down or the no-start complaint?	
STEP 3C: Monitor the engine speed during cranking.	Is the engine speed greater than 150 rpm during cranking?	

STEP 3D:	Monitor the ECM keyswitch input.	Does the User Fueling State indicate cranking or is keyswitch voltage equal to battery voltage?
STEP 3E:	Monitor the ECM battery supply.	Is the ECM battery supply voltage greater than +11-VDC for 12 volt systems or +22-VDC for 24 volt systems?
STEP 3F:	Check the load carrying capabilities of the ECM power and ground circuits.	Do the headlights illuminate brightly?
STEP 3G:	Check orientation of connector.	Is the rail fuel pressure sensor connector installed correctly?
STEP 3H:	Verify rail fuel pressure sensor accuracy.	Is the Fuel Rail Pressure (measured) less than 30 bar [435 psi]?
STEP 3I:	Monitor fuel rail pressure while cranking the engine.	Did the Fuel Rail Pressure (measured) equal the Fuel Rail Pressure (commanded)?
STEP 4:	Fuel system troubleshooting procedures.	
STEP 4A:	Check for air in the fuel supply line.	Is air present in the fuel supply?
STEP 4B:	Check for air in the high pressure pump fuel supply.	Is the pressure measured within specification?
STEP 4B-1:	Measure the fuel inlet restriction.	Is the pressure measured within specification?
STEP 4C:	Measure fuel pressure at the outlet of the on engine fuel filter.	Is the pressure drop across the filter greater than the specification?
STEP 4D:	Perform INSITE™ electronic service tool single cylinder cutout test.	Can the miss or excessive smoke be attributed to a single cylinder?
STEP 4E:	Perform a manual single cylinder cut-out test.	Did the engine start after blocking off a cylinder(s) or can the miss or excessive smoke be attributed to a cylinder(s)?
STEP 4F:	Measure the injector return fuel drain flow from the cylinder head.	Is injector fuel drain flow from the cylinder head greater than specification?
STEP 4G:	Determine which cylinder(s) is causing excessive injector fuel drain flow from the cylinder head.	Did blocking off a cylinder(s) decrease the flow rate below the maximum specified flow rate?
STEP 4H:	Monitor Commanded Fuel Rail Pressure and Measured Fuel Rail Pressure.	Does the Measured Fuel Rail Pressure vary more than ± 35 bar [± 500 psi] from the Commanded Fuel Rail Pressure?
STEP 4I:	Check the fuel pressure relief valve for excessive leakage.	Is the fuel pressure relief valve within specification?
STEP 4J:	Measure the high-pressure fuel supply pump fuel drain flow.	Is the high pressure fuel supply pump fuel return flow greater than specification?
STEP 4K:	Measure fuel drain line restriction.	Is the drain line restriction less than specification?

STEP 5: Air handling troubleshooting procedures.

- | | | |
|-------------------|---|---|
| STEP 5A: | Check intake manifold pressure sensor accuracy. | Intake manifold pressure reading is less than 102 mm-Hg [4 in-Hg]? |
| STEP 5B: | Check the air intake system for leaks. | Were any air intake system leaks found? |
| STEP 5C: | Check air intake restriction. | Is the air intake restriction greater than the specification? |
| STEP 5D: | Inspect the turbocharger compressor blades for damage. | Damage found on turbocharger blades? |
| STEP 5E: | Determine if the turbocharger is a wastegated turbocharger. | Is the turbocharger a wastegated turbocharger? |
| STEP 5F: | Inspect the wastegate actuator hose. | Holes or cracks found in the wastegate actuator hose? |
| STEP 5G: | Inspect the turbocharger wastegate capsule for air leaks. | Did the wastegate actuator capsule leak air? |
| STEP 5G-1: | Inspect the turbocharger wastegate for proper operation. | Did the wastegate actuator rod move? |
| STEP 5G-2: | Inspect the turbocharger wastegate for proper operation. | Does the wastegate actuator rod move? |
| STEP 5H: | Measure turbocharger axial and radial clearance. | Are the axial and radial clearances within specification? |
| STEP 5I: | Inspect the charge-air cooler. | Does the charge-air cooler pass the visual inspection as well as the pressure test and temperature differential test? |

STEP 6: Verify electronic features are operating correctly.

- | | | |
|-----------------|---|---|
| STEP 6A: | Verify accelerator (throttle) pedal travel. | Does the accelerator (throttle) position read 0 percent when the accelerator (throttle) is fully released and 100 percent when the accelerator (throttle) is fully depressed? |
| STEP 6B: | Monitor the vehicle speed. | Does the vehicle speed read zero when the vehicle is not moving? |
| STEP 6C: | Verify electronic feature settings are correct. | Are electronic features set correctly? |
| STEP 6D: | Check temperature sensor accuracy. | Are all temperature readings within 5.6°C or 10°F of each other? |
| STEP 6E: | Check ambient air pressure sensor accuracy. | INSITE™ electronic service tool reading is within 50.8 mm-Hg [2 in-Hg] of local barometric pressure? |

STEP 7: Perform base engine mechanical checks.

- | | | |
|-----------------|--|---|
| STEP 7A: | Verify overhead adjustments are correct. | Are the overhead settings within the lash check limits? |
|-----------------|--|---|

STEP 7B:	Check exhaust restriction.	Is the exhaust back pressure greater than the specification?
STEP 7C:	Verify engine crankcase pressure (blowby) is within specification.	Is the engine crankcase pressure (blowby) less than specification?
STEP 7D:	Check for internal engine damage.	Did cutting the oil filter open reveal evidence of internal engine damage?
STEP 8:	Excessive vibration checks.	
STEP 8A:	Check engine idle speed.	Is the engine idle speed within specification?
STEP 8B:	Check if the feature Fast Idle Warm Up is available and enabled.	Is the feature Fast Idle Warm Up available and enabled?
STEP 8B-1:	Monitor if the Fast Idle Warm Up Status.	Is the feature Fast Idle Warm Up becoming active?
STEP 8C:	Check front engine driven accessory(s).	Did isolating the front engine driven accessory(s) correct the vibration?
STEP 8D:	Check the vibration damper/ crankshaft speed indicator ring.	Is the vibration damper/ crankshaft speed indicator ring damaged?
STEP 8E:	Check the engine support brackets, mounts, and/or isolators.	Are the engine support brackets, mounts, and/or isolators or damaged?
STEP 8F:	Check engine gear driven accessory(s).	Does the engine have an engine gear driven/air compressor driven hydraulic pump?
STEP 8F-1:	Isolate engine gear driven accessory(s).	Did isolating/removing engine gear driven/air compressor driven hydraulic pump correct the vibration?
STEP 8F-2:	Check if the engine is equipped with an air compressor.	Is the engine equipped with an engine gear driven air compressor?
STEP 8F-3:	Unload the air compressor and operate.	Did unloading the air compressor significantly reduce or eliminate the vibration?
STEP 8F-4:	Check air compressor timing.	Was the air compressor correctly timed to the engine?
STEP 8G:	Check/isolate engine driven components.	Did isolating/removing any engine driven component correct the vibration?
STEP 8H:	Check the flywheel housing alignment.	Is the flywheel housing bore and face runout within specification?
STEP 8I:	Check if engine is equipped with an internal engine balancer.	Is the engine equipped with an internal engine balancer?
STEP 8I-1:	Check the internal engine balancer.	Is the internal engine balancer timing incorrect or is the balancer damaged?

TROUBLESHOOTING STEP

STEP 1: Perform basic troubleshooting procedures.

STEP 1A: Check for active fault codes or high counts of inactive fault codes.

Condition: <ul style="list-style-type: none"> • Turn keyswitch ON. • Connect INSITE™ electronic service tool. 		
Action	Specification/Repair	Next Step
Check for any active fault code. <ul style="list-style-type: none"> • Use INSITE™ electronic service tool to read the fault codes. • See the corresponding Electronic Control System Troubleshooting and Repair Manual for the engine being serviced. • For engines equipped with a CM800 Electronic Control Module, refer to Bulletin 3666477. • For engines equipped with a CM850 Electronic Control Module, refer to Bulletin 4021416. 	Active fault codes or high counts of inactive fault codes? YES Repair: Follow the electronic fault code trees for the appropriate troubleshooting procedures.	Repair complete
	Active fault codes or high counts of inactive fault codes? NO	1B

STEP 1B: Perform basic troubleshooting checks.

Condition: N/A		
Action	Specification/Repair	Next Step
The following items must be checked or verified before continuing: <ul style="list-style-type: none"> • Verify the fuel level in the tanks. • Verify the vehicle is in good working order • Check if any recent maintenance or service work has been performed • Verify there have not been any changes to CPL components on the engine. • Verify fuel grade is correct for the application. • Verify the engine is operating within the recommended altitude. • Verify the engine oil is in good condition and at the correct level. • Verify the engine parasitics have not changed. • Verify the engine duty cycle has not changed. • Verify the air filter is not excessively plugged by checking filter minder. • Listen for air and exhaust leaks. • Verify there are no visible external fuel leaks. • Verify there are no visible coolant leaks. • Verify the crankshaft position and the camshaft position sensors are correctly connected to the engine harness. 	All steps have been verified to be correct? YES	2A
	All steps have been verified to be correct? NO Repair: Correct the step and verify complaint is no longer present after repair.	Repair complete

STEP 2: Determination of engine symptom.

STEP 2A: Engine Difficult to Start or Will Not Start (With or Without Exhaust Smoke), Engine Shuts Off or Dies Unexpectedly or Dies During Deceleration, or Engine Starts but Will Not Keep Running

Condition: N/A		
Action	Specification/Repair	Next Step
Interview the driver and verify the complaint. N/A	Is the engine symptom Engine Difficult to Start or Will Not Start (With or Without Exhaust Smoke), Engine Shuts Off or Dies Unexpectedly or Dies During Deceleration, or Engine Starts but Will Not Keep Running? YES Repair: Perform the troubleshooting steps in the recommended order listed below: Step 3 - Engine will Not Start or Stalls Troubleshooting Procedures Step 4 - Fuel System Checks Step 5 - Air Handling Checks Step 6 - Electronics Checks	Perform the troubleshooting steps suggested in the repair procedure.
	Is the engine symptom Engine Difficult to Start or Will Not Start (With or Without Exhaust Smoke), Engine Shuts Off or Dies Unexpectedly or Dies During Deceleration, or Engine Starts but Will Not Keep Running? NO	2B

STEP 2B: Engine Runs Rough at Idle, Engine Runs Rough or Misfires, Engine Speed Surges at Low or High Idle, Engine Speed Surges under Load or in Operating Range.

Condition: N/A		
Action	Specification/Repair	Next Step
Interview the driver and verify the complaint. N/A	Is the engine symptom Engine Runs Rough at Idle, Engine Runs Rough or Misfires, Engine Speed Surges at Low or High Idle, Engine Speed Surges under Load or in Operating Range? YES Repair: Perform the troubleshooting steps in the recommended order listed below: Step 4 - Fuel System Checks Step 6 - Electronic Checks Step 5 - Air Handling Checks Step 7 - Base Engine Checks	Perform the troubleshooting steps suggested in the repair procedure.
	Is the engine symptom Engine Runs Rough at Idle, Engine Runs Rough or Misfires, Engine Speed Surges at Low or High Idle, Engine Speed Surges under Load or in Operating Range? NO	2C

STEP 2C: Smoke, Black - Excessive.

Condition: N/A		
Action	Specification/Repair	Next Step
Interview the driver and verify the complaint. N/A	Is the engine symptom Smoke, Black - Excessive? YES Repair: Perform the troubleshooting steps in the recommended order listed below: Step 5 - Air Handling Checks Step 4 - Fuel System Checks Step 6 - Electronics Checks Step 7 - Base Engine Checks	Perform the troubleshooting steps suggested in the repair procedure.
	Is the engine symptom Excessive White Smoke and is the engine using coolant? NO	2D

STEP 2D: Smoke, White - Excessive

Condition: N/A		
Action	Specification/Repair	Next Step
Interview the driver and verify the complaint. N/A	Is the engine symptom Smoke, White - Excessive? YES	2D-1
	Is the engine symptom Smoke, White - Excessive? NO	2E

STEP 2D-1: Smoke, White - Excessive

Condition: N/A		
Action	Specification/Repair	Next Step
Interview the driver and verify the complaint. Verify if, along with the white smoke complaint, coolant is being used. Check the coolant level.	Is the engine using coolant? YES	See the Coolant Loss - Internal Troubleshooting Symptom (TS) Tree.
	Is the engine using coolant? NO	2D-2

STEP 2D-2: Smoke, White - Excessive

Condition: N/A		
Action	Specification/Repair	Next Step
Interview the driver and verify the complaint. Check if the white smoke excessive complaint is only occurring when the engine is cold and during cold ambient conditions? Some white smoke after a cold start in cold ambient conditions is not uncommon. If white smoke persists once the engine has reached the minimum operating coolant temperature, troubleshoot the white smoke complaint. Minimum Operating Coolant Temperature: 60°C [140°F].	Is the white smoke excessive complaint only occurring when the engine is cold and during cold ambient conditions? YES Repair: Perform the checks in Step 3A only. Step 4 - Fuel System Checks. Step 6 - Electronics Checks.	Perform the troubleshooting steps suggested in the repair procedure.
	Is the white smoke excessive complaint only occurring when the engine is cold and during cold ambient conditions? NO Repair: Perform the troubleshooting steps in the recommended order listed below: Step 4 - Fuel System Checks Step 7 - Perform Base Engine Mechanical Checks.	N/A

STEP 2E : Engine Acceleration or Response Poor, Engine Power Output Low, Engine Decelerates Slowly, Intake Manifold Pressure (Boost) is Below Normal or Engine Will Not Reach Rated Speed (RPM).

Condition: N/A		
Action	Specification/Repair	Next Step
Interview the driver and verify the complaint. N/A	Is the engine symptom Engine Acceleration or Response Poor, Engine Power Output Low, Engine Decelerates Slowly, Intake Manifold Pressure (Boost) is Below Normal or Engine Will Not Reach Rated Speed (RPM)? YES Repair: Perform the troubleshooting steps in the recommended order listed below: Step 5 - Air Handling Checks Step 4 - Fuel Systems Checks Step 6 - Electronic Checks Step 7 - Base Engine Checks	Perform the troubleshooting steps suggested in the repair procedure.
	Is the engine symptom Engine Acceleration or Response Poor, Engine Power Output Low, Engine Decelerates Slowly, Intake Manifold Pressure (Boost) is Below Normal or Engine Will Not Reach Rated Speed (RPM)? NO	2F

STEP 2F : Engine Vibration - Excessive

Condition: N/A		
Action	Specification/Repair	Next Step
Interview the driver and verify the complaint. N/A	Is the engine symptom Engine Vibration Excessive? YES Repair: Perform the troubleshooting steps in the recommended order listed below: Perform Step 4E of the Fuel System Checks Step 8 - Excessive Vibration Checks Step 7 - Base Engine Checks Is the engine symptom Engine Vibration Excessive?	Perform the troubleshooting steps suggested in the repair procedure.
	Is the engine symptom Engine Vibration Excessive? NO	For engine related symptoms, see the correct troubleshooting symptom (TS) tree.

STEP 3: Engine will Not Start or Stalls Troubleshooting Procedures

STEP 3A: Verify the operation of cold weather aids.

Condition: <ul style="list-style-type: none"> • Engine and Ambient Conditions Cold • Turn keyswitch ON. 		
Action	Specification/Repair	Next Step
Make sure that necessary cold weather starting aids are operational as required: Minimum Ambient Air Temperature for Unaided Cold Start is minus 12.2°C [10°F]. INSITE™ electronic service tool Intake Air Heater Override test can be used to diagnose intake air heater problems. For engines equipped with air intake heaters, the air intake heaters should begin to function at 19°C [66°F].	Are the necessary cold weather starting aids being used and are they operational as required? YES	3B
	Are the necessary cold weather starting aids being used and are they operational as required? NO Repair: Install or repair cold weather starting aids. Use the following procedures in the Service Manual, ISBe, ISB, and QSB (Common Rail Fuel System), Bulletin 4021271. Refer to Procedure 008-011 in Section 8. Refer to Procedure 007-001 in Section 7. For any OEM installed cold starting aids (radiator shutters, etc.), refer to the OEM service manual.	Repair complete

STEP 3B: Check electronic features and programmable parameters.

Condition: <ul style="list-style-type: none"> • Turn keyswitch ON. • Connect INSITE™ electronic service tool. 		
Action	Specification/Repair	Next Step
Check if the electronic features and programmable parameters are the cause for the engine shutting down or the no-start complaint. The electronic features and programmable parameters include: Idle Shutdown, Engine Protection Shutdown, and Vehicle Anti-theft Protection.	Are electronic features and programmable parameters the cause for the engine shutting down or the no-start complaint? YES Repair: Program the electronic features per the customer or OEM requirements.	Repair Complete
	Are electronic features and programmable parameters the cause for the engine shutting down or the no-start complaint? NO	3C

STEP 3C: Monitor the engine speed during cranking.

<p>Condition:</p> <ul style="list-style-type: none"> • Turn keyswitch ON. • Connect INSITE™ electronic service tool. • INSITE Monitor 		
Action	Specification/Repair	Next Step
<p>Monitor the engine speed during cranking. Use INSITE™ electronic service tool. Attempt to start the engine; engage the engine starter for at least 30 continuous seconds. Do not overheat the starter. Attempting to start the engine for 30 continuous seconds also allows the fault code logic time to run. If any fault codes become active, stop using this troubleshooting tree and reference the corresponding fault code troubleshooting tree.</p>	<p>Is the engine speed greater than 150 rpm during cranking? YES Repair: N/A</p>	3D
	<p>Is the engine speed greater than 150 rpm during cranking? NO Repair: Find and correct the cause for low cranking speed. Consider the batteries, engine starting motor, drive units, and accessory loads.</p>	See the Engine Will not Crank or Cranks Slowly (Electric or Air Starter) troubleshooting symptom (TS) tree.

STEP 3D: Monitor the ECM Keyswitch Input.

<p>Condition:</p> <ul style="list-style-type: none"> • Turn keyswitch ON. • Connect INSITE™ electronic service tool. • Engine not operating 		
Action	Specification/Repair	Next Step
<p>Monitor User Fueling State and key switch while cranking the engine. Use INSITE™ electronic service tool. If the engine is intermittently shutting down, User Fueling State can also be monitored during engine shut down. If INSITE™ electronic service tool is not available: Disconnect the OEM harness from the ECM. Turn keyswitch ON. Measure the signal voltage from the keyswitch input signal wire of the OEM harness to the engine block ground. Measure the keyswitch voltage with the keyswitch in the ON position and also with the keyswitch in the cranking position. Consult the corresponding wiring diagram for the engine being serviced for connector pin identification.</p>	<p>Does the User Fueling State indicate cranking or is keyswitch voltage equal to battery voltage? YES</p>	3E
	<p>Does the User Fueling State indicate Cranking or is keyswitch voltage equal to battery voltage? NO Repair: Check the keyswitch battery supply circuit. Use the following procedure in the Electronic Control System Troubleshooting and Repair manual. Refer to Procedure 019-064 in Section 19. Repair or replace the OEM harness or keyswitch, or check the battery connections. Refer to the OEM service manual for the proper procedures.</p>	Repair Complete

STEP 3E: Monitor the ECM Battery Supply.

<p>Condition:</p> <ul style="list-style-type: none"> • Turn keyswitch ON. • Connect INSITE™ electronic service tool. • Engine not operating 		
Action	Specification/Repair	Next Step
<p>Monitor Battery Voltage while cranking the engine.</p> <p>Use INSITE™ electronic service tool.</p> <p>If INSITE™ electronic service tool is not available:</p> <ul style="list-style-type: none"> • Disconnect the ECM power supply connection. • Turn keyswitch ON. <p>Measure the voltage from the ECM battery SUPPLY (-) pin(s) to the ECM battery SUPPLY (+) pin(s) in the ECM connector.</p> <p>Measure the ECM voltage with the keyswitch in the ON position and also with the keyswitch in the cranking position.</p> <p>See to the corresponding wiring diagram for the engine being serviced for connector pin identification.</p>	<p>Is the ECM battery supply voltage greater than +11-VDC for 12 volt systems or +22-VDC for 24 volt systems?</p> <p>YES</p>	3F
	<p>Is the ECM battery supply voltage greater than +11-VDC for 12 volt systems or +22-VDC for 24 volt systems?</p> <p>NO</p> <p>Repair:</p> <p>Repair or replace the ECM power and ground connections. Check the battery connections and fuse terminals.</p>	Repair complete

STEP 3F: Check the load carrying capabilities of the ECM power and ground circuits.

<p>Condition:</p> <ul style="list-style-type: none"> • Turn keyswitch OFF. • Disconnect the ECM power supply connector from the ECM. 		
Action	Specification/Repair	Next Step
<p>Connect a headlight (12 volt or 24 volt systems). A headlight must be used to make sure that the wattage rating will put enough of a load on the circuit.</p> <p>Use the ECM battery SUPPLY (+) pin in the ECM power supply connection for the battery positive (+) and the ECM battery SUPPLY (-) pin in the ECM power harness connector for the battery negative (-).</p> <p>Consult the corresponding wiring diagram for the engine being serviced for connector pin identification.</p>	<p>Do the headlights illuminate brightly?</p> <p>YES</p>	3G
	<p>Do the headlights illuminate brightly?</p> <p>NO</p> <p>Repair:</p> <p>Repair or replace the ECM power and ground connections. Check the battery connections and fuse terminals.</p>	Repair complete

STEP 3G: Check orientation of connector.

Condition: <ul style="list-style-type: none"> Turn keyswitch OFF. 		
Action	Specification/Repair	Next Step
Check for the appropriate orientation of the rail fuel pressure sensor connector. Connector can be incorrectly installed, rotated 180 degrees.	Is the rail fuel pressure sensor connector installed correctly? YES	3H
	Is the rail fuel pressure sensor connector installed correctly? NO Repair: Reorient connector.	Repair complete

STEP 3H: Verify rail fuel pressure sensor accuracy.

Condition: <ul style="list-style-type: none"> Turn keyswitch ON Connect INSITE™ electronic service tool INSITE™ Monitor Engine not operating. 		
Action	Specification/Repair	Next Step
Monitor the fuel rail pressure. Use INSITE™ electronic service tool to measure the fuel rail pressure.	Is the Fuel Rail Pressure (measured) less than 30 bar (435 psi)? YES	3I
	Is the Fuel Rail Pressure (measured) less than 30 bar (435 psi)? NO Repair: Replace the rail fuel pressure sensor. Use the following procedure in the ISB (4 cylinder) and ISBe (4 and 6 cylinder) Electronic Control System Troubleshooting and Repair manual, Bulletin 3666477. Refer to Procedure 019-115 in Section 19. Use the following procedure in the ISB, ISBe2, ISBe3, ISBe4, QSB4.5, QSB5.9, QSB6.7, ISC, QSC8.3, ISL, ISLe3, ISLe4, and QSL9 CM850 Electronic Control System Troubleshooting and Repair Manual, Bulletin 4021416. Refer to Procedure 019-115 in Section 19.	Repair Complete

STEP 3I: Monitor fuel rail pressure while cranking the engine.

<p>Condition:</p> <ul style="list-style-type: none"> • Turn keyswitch ON. • Connect INSITE™ electronic service tool • INSITE™ Monitor. 		
Action	Specification/Repair	Next Step
<p>Monitor Fuel Rail Pressure (measured) and Fuel Rail Pressure (commanded). Use INSITE™ electronic service tool. Fuel Rail Pressure (commanded) can also be referred to as HPCR fuel setpoint. Attempt to start the engine, engage the engine starter for at least 30 continuous seconds. Do not overheat the starter. A minimum of 100 bar [1450 psi] of fuel rail pressure is required before the injectors will open and provide fuel. Attempting to start the engine for 30 continuous seconds allows the fault code logic time to perform. If Fault Code 2215 or 559 becomes active, adequate fuel rail pressure is not being developed. Discontinue using this troubleshooting tree and troubleshoot Fault Code 2215 or 559.</p>	<p>Did the Fuel Rail Pressure (measured) equal the Fuel Rail Pressure (commanded)? YES</p>	5A
	<p>Did the Fuel Rail Pressure (measured) equal the Fuel Rail Pressure (commanded)? NO</p>	4A

STEP 4: Fuel system troubleshooting procedures.

STEP 4A: Check for air in the fuel supply line.

Condition:

- Turn keyswitch OFF.
- Engine OFF.
- Connect required service tools at the gear pump inlet.

Action	Specification/Repair	Next Step
<p>Check for air in the fuel</p> <p>Use the following procedure in the ISBe, ISB, and QSB (Common Rail Fuel System) Service Manual, Bulletin 4021271. Refer to Procedure 006-003 in Section 6. Operate the engine at idle and check for air bubbles. If the engine will not start, check while cranking the engine.</p> <p>Do not overheat the starter.</p>	<p>Is air present in the fuel supply?</p> <p>YES</p> <p>Repair:</p> <p>Locate and correct the cause of air ingestion in the fuel supply system. Sources of air ingestion include loose fuel filters, loose fuel line fittings, loose or cracked fuel tank stand-pipes, or severe restrictions in the fuel supply lines and filters that cause cavitation at high fuel flow rates.</p>	<p>Repair complete</p>
	<p>Is air present in the fuel supply?</p> <p>NO</p>	<p>4B</p>

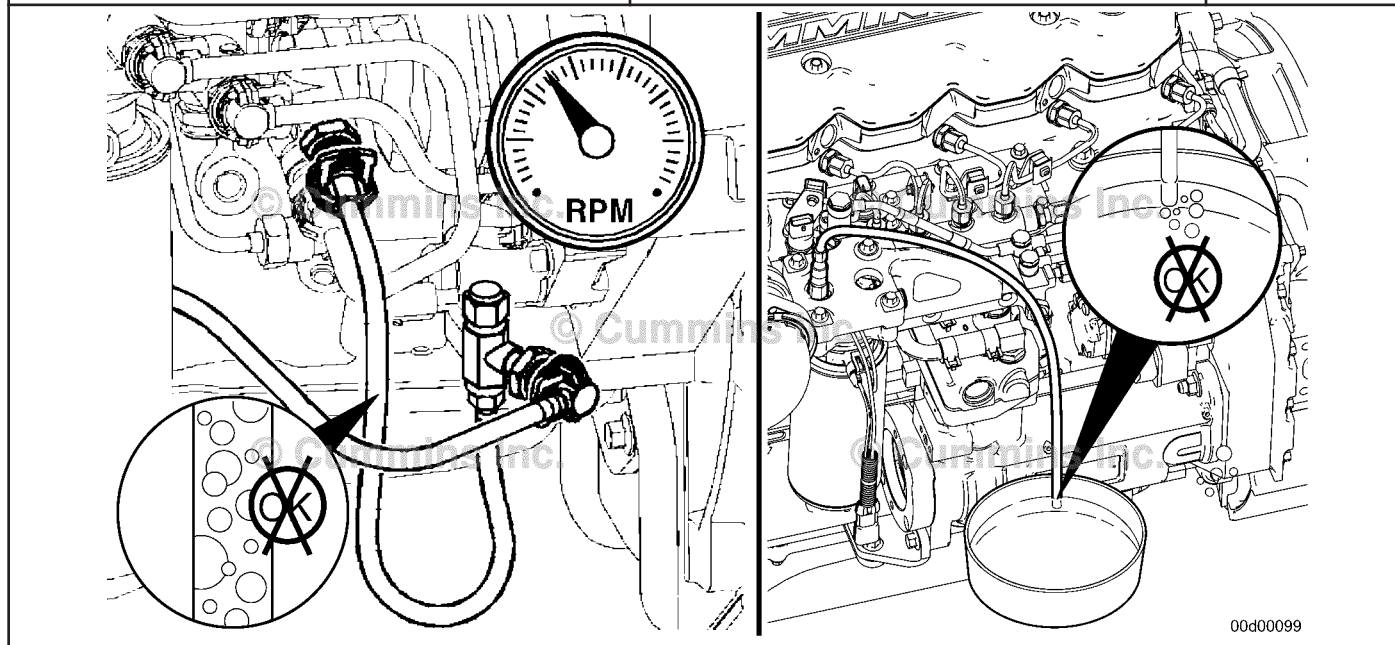

STEP 4B: Measure fuel pressure at the inlet of the on engine fuel filter.

Condition:

- Turn keyswitch OFF.
- Engine OFF.
- Connect required service tools at the inlet to the fuel filter, or if equipped, the fuel filter head diagnostic port (inlet).

Action	Specification/Repair	Next Step
Check for air in the fuel Use the following procedure in Service Manual, ISBe, ISB, and QSB (Common Rail Fuel System) Series Engines, Bulletin 4021271. Refer to Procedure 006-015 in Section 6.	Is the pressure measured within specification? Record the measured fuel inlet pressure for use in the next step. YES	4C
Measure the fuel pressure at low idle: <ul style="list-style-type: none"> • Fuel pressure range: 5 to 13 bar [73 to 189 psi]. If the engine will not start, measure the fuel pressure during engine cranking <ul style="list-style-type: none"> • Fuel pressure range: 3 to 11 bar [44 to 160 psi]. Record the fuel filter inlet pressure measured.	Is the pressure measured within specification? NO	4B-1

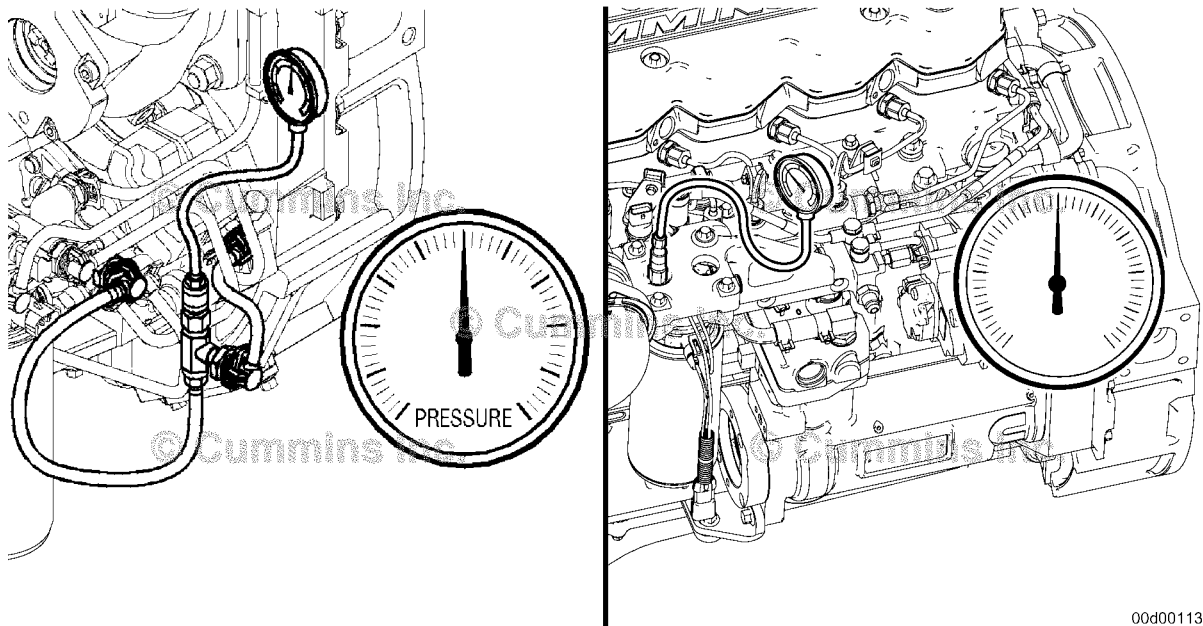

00d00113

STEP 4B-1: Measure the fuel inlet restriction.

Action	Specification/Repair	Next Step
<p>Condition:</p> <ul style="list-style-type: none"> • Turn keyswitch OFF. • Engine OFF. • Connect required service tools at the gear pump inlet. <p>Measure the fuel inlet restriction.</p> <p>Service Manual, ISBe, ISB, and QSB (Common Rail Fuel System) Series Engines, Bulletin 4021271. Operate the engine at high idle:</p> <p>Maximum inlet restriction - 50.8 kPa [15 in-Hg] (vacuum)</p> <p>If the engine will not start, measure fuel restriction while the engine is cranking.</p> <p>Do not overheat the starter.</p>	<p>Is the fuel inlet restriction greater than the specification?</p> <p>YES</p> <p>Repair:</p> <p>Find and correct cause of high inlet restriction. Look for plugged OEM fuel filters or screens, or a restricted ECM cooler, pinched OEM fuel lines, or restricted stand pipe in the OEM fuel tank.</p>	<p>Repair Complete</p>
<p>If the issue is intermittent (no start or engine shuts off unexpectedly) and no issues can be found while the engine is being serviced, there can be debris in the fuel system causing an intermittent restriction. Install a fuel filter minder, Fleetguard® Part Number 3892576, at the connection between the OEM fuel supply lines and the engine. A fuel filter minder will capture the peak restriction in millimeters and inches of mercury. If the issue occurs again, the fuel filter minder can be checked to see if there is something on the OEM side causing an intermittent high restriction.</p>	<p>Is the fuel inlet restriction greater than the specification?</p> <p>NO</p> <p>Repair:</p> <p>Replace the high pressure fuel pump. Use the following procedure in the ISBe, ISB, and QSB (Common Rail Fuel System) Service Manual, Bulletin 4021271. Refer to Procedure 005-016 in Section 5.</p>	<p>Repair Complete</p>

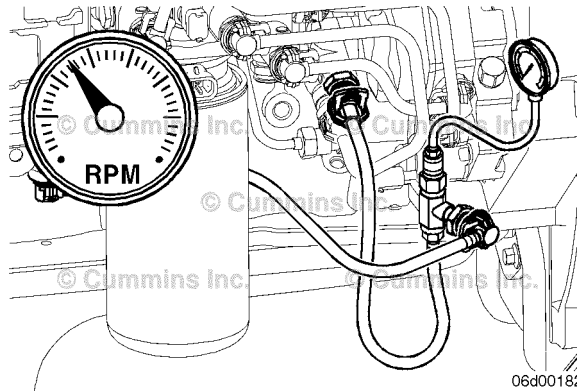

STEP 4C: Measure fuel pressure at the outlet of the on engine fuel filter.

<p>Condition:</p> <ul style="list-style-type: none"> • Turn keyswitch OFF. • Engine OFF. • Connect required service tools at the outlet of the fuel filter, or if equipped, the fuel filter head diagnostic port (outlet). 		
Action	Specification/Repair	Next Step
<p>Measure fuel pressure at the outlet of the fuel filter.</p> <p>Use the following procedure in Service Manual, ISBe, ISB, and QSB (Common Rail Fuel System) Series Engines, Bulletin 4021271. Refer to Procedure 006-015 in Section 6.</p> <p>Calculate the pressure drop across the fuel filter by subtracting the pressure measured here from the pressure from Step 4B.</p> <p>Measure the fuel pressure at high idle:</p> <ul style="list-style-type: none"> • Maximum pressure drop across the fuel filter - 2 bar [29 psi]. <p>If the engine will not start, measure the fuel pressure during engine cranking</p>	<p>Is the pressure drop across the filter greater than the specification?</p> <p>YES</p> <p>Repair:</p> <p>Replace the fuel filter. Use the following procedure in Service Manual, ISBe, ISB, and QSB (Common Rail Fuel System) Series Engines, Bulletin 4021271. Refer to Procedure 006-015 in Section 6.</p>	<p>Repair Complete</p>
	<p>Is the pressure drop across the filter greater than the specification?</p> <p>NO</p>	<p>4D</p>

STEP 4D: Perform INSITE electronic service tool single cylinder cutout test.

<p>Condition:</p> <ul style="list-style-type: none"> • Turn keyswitch ON. • Engine operating at low idle. • Connect INSITE™ electronic service tool. 		
Action	Specification/Repair	Next Step
<p>If the engine will not start or is difficult to start, move to the next step.</p> <ul style="list-style-type: none"> • In the ECM Diagnostic Tests menu of INSITE™ electronic service tool, click on the Cylinder Cutout Test, and follow the instructions on the screen. • Operate the engine under the conditions in which the complaint occurs. • Use INSITE™ electronic service tool to perform the Cylinder Cutout Test to disable individual injectors. <p>If this test is performed and there is not a significant change while cutting out one injector, there can be a problem with more than one injector. It may be necessary to cut out multiple cylinders at a time.</p>	<p>Can the miss or excessive smoke be attributed to a single cylinder?</p> <p>YES</p> <p>Repair:</p> <p>Look for a cause of the complaint, including valve lash and excessive crankcase pressure that may indicate power cylinder damage or camshaft lobe wear. If no other damage is found, replace the fuel injector in the cylinder that was identified using the single cylinder cutout test. Use the following procedure in Service Manual, ISBe, ISB, and QSB (Common Rail Fuel System) Series Engines, Bulletin 4021271. Refer to Procedure 006-026 in Section 6</p>	<p>Repair Complete</p>
	<p>Can the miss or excessive smoke be attributed to a single cylinder?</p> <p>NO</p>	<p>4E</p>

STEP 4E: Perform a manual single cylinder cut-out test.

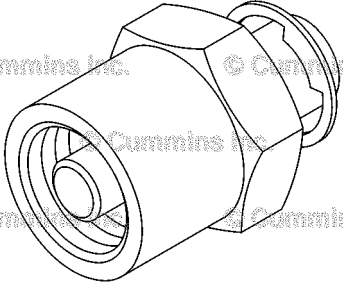
Action	Specification/Repair	Next Step
<p>Condition:</p> <ul style="list-style-type: none"> • Turn keyswitch OFF. • Install the injector leakage isolation tool. • Turn keyswitch ON. <p>Perform a manual cut-out test.</p> <ul style="list-style-type: none"> • With the engine not operating, disconnect the fuel line routed from the fuel rail to cylinder number 1. Use the following procedure in Service Manual, ISBe, ISB, and QSB (Common Rail Fuel System) Series Engines, Bulletin 4021271. Refer to Procedure 006-051 in Section 6. • Install the injector leakage isolation tool <p>For 3.9L and 5.9L engines, install the injector leakage isolation tool, Part Number 3164325, on the rail where the number 1 cylinder fuel line connects.</p> <p>Torque Value: 30 N•m [22 ft-lb]</p> <p>For 4.5L and 6.7L engines, install the leakage isolation tool, Part Number 4918298, on the rail where the number 1 cylinder fuel line connects.</p> <p>Torque Value: 35 N•m [26 ft-lb]</p> <p>Attempt to start the engine or operate the engine at idle.</p> <p>Repeat the above test, as necessary, with each cylinder blocked off.</p>	<p>Did the engine start after blocking off a cylinder(s) or can the miss or excessive smoke be attributed to a cylinder(s)?</p> <p>YES</p> <p>Repair:</p> <p>Look for a cause of the complaint, including valve lash and excessive crankcase pressure that can indicate power cylinder damage or camshaft lobe wear. If no other damage is found, replace the fuel injector in the cylinder that was identified using the manual single cylinder cut-out test. Use the following procedure in Service Manual, ISBe, ISB, and QSB (Common Rail Fuel System) Series Engines, Bulletin 4021271. Refer to Procedure 006-026 in Section 6</p> <hr/> <p>Did the engine start after blocking off a cylinder(s) or can the miss or excessive smoke be attributed to a cylinder(s)?</p> <p>NO</p>	<p>Repair Complete</p> <hr/> <p>4F</p>
<div style="text-align: center;">  <p>© Cummins Inc. © Cummins Inc. © Cummins Inc. © Cummins Inc. © Cummins Inc. © Cummins Inc.</p> <p>06d00259</p> </div>		

STEP 4F: Measure the injector return fuel drain flow from the cylinder head.

<p>Condition:</p> <ul style="list-style-type: none"> • Turn keyswitch OFF. • Connect appropriate service tools to measure injector fuel drain flow from the cylinder head. 		
Action	Specification/Repair	Next Step
<p>Measure the injector return fuel drain flow from the cylinder head.</p> <p>Use the following procedure in the ISBe, ISB, and QSB Service Manual, Bulletin 4021271. Refer to Procedure 006-026 in Section 6.</p> <p>Flow Specification:</p> <p>Idle Conditions</p> <p>4 cylinder engines - 120 ml/minute [4 fl-oz per minute] maximum</p> <p>6 cylinder engines - 180 ml/minute [6 fl-oz per minute] maximum</p> <p>Cranking Conditions</p> <p>Make sure not to overheat the starter.</p> <p>4 and 6 cylinder engines - 90 ml/minute [3 fl-oz per minute] maximum.</p>	<p>Is injector fuel drain flow from the cylinder head greater than specification?</p> <p>YES</p>	4G-1
	<p>Is injector fuel drain flow from the cylinder head greater than specification?</p> <p>NO</p>	4H

STEP 4G: Determine which cylinder(s) is causing excessive injector fuel drain flow from the cylinder head.

<p>Condition:</p> <ul style="list-style-type: none"> • Turn keyswitch OFF. • Connect appropriate service tools to measure injector fuel drain flow from the cylinder head. • Install the injector leakage isolation tool. 		
Action	Specification/Repair	Next Step
<p>Measure the injector return fuel drain flow from the cylinder head and isolate a cylinder one at a time using the injector leakage isolation tool.</p> <p>Use the following procedure in the ISBe, ISB, and QSB Service Manual, Bulletin 4021271. Refer to Procedure 006-026 in Section 6.</p> <p>The flow rate will decrease below the maximum specified flow when the cylinder with the leak is blocked.</p> <p>If this test is performed and there is not a significant change in fuel return flow while cutting out one injector, there can be a problem with more than one injector. Compare the fuel flow difference across all injectors. Is there more than one injector that caused a noticeable decrease in fuel flow? If so, these could be the injectors with the problems.</p> <p>Another cause of this problem could be that the customer is operating on fuels lighter than specified. Fuels with low viscosity will result in higher injector leakage and greater drain flow rates.</p>	<p>Did blocking off a cylinder(s) decrease the flow rate below the maximum specified flow rate?</p> <p>YES</p> <p>Repair:</p> <p>Remove the fuel connector and inspect for damage. Replace if necessary. Remove the injector and inspect the fuel connector contact surface for damage. Replace if necessary. Use the following procedures in the ISBe, ISB, and QSB Service Manual, Bulletin 4021271. Refer to Procedure 006-052 in Section 6. Refer to Procedure 006-026 in Section 6.</p>	Repair Complete
	<p>Did blocking off a cylinder(s) decrease the flow rate below the maximum specified flow rate?</p> <p>NO</p>	4H

STEP 4H: Monitor Commanded Fuel Rail Pressure and Measured Fuel Rail Pressure.

<p>Condition:</p> <ul style="list-style-type: none"> • Turn keyswitch ON. • Electronic service tool connected. • Engine idling. 		
Action	Specification/Repair	Next Step
<p>Use an electronic service tool to monitor Commanded Fuel Rail Pressure and Measured Fuel Rail Pressure while the engine is idling.</p> <p>When monitoring, note whether any engine driven accessory (air conditioning compressor, air compressor, fan clutch, etc.) turns on. Also, note whether any accessories that put demand/load on the alternator (intake air heater, vehicle accessories, etc.). These items can affect the outcome of this check. The load on the engine should be constant.</p>	<p>Does the Measured Fuel Rail Pressure vary more than ± 35 bar [± 500 psi] from the Commanded Fuel Rail Pressure?</p> <p>YES</p> <p>Repair:</p> <p>Replace the fuel pump actuator. Use the following procedure in the ISBe, ISB, and QSB (Common Rail Fuel System) Service Manual, Bulletin 4021271. Refer to Procedure 005-007 in Section 5.</p>	Repair complete
	<p>Does the Measured Fuel Rail Pressure vary more than ± 35 bar [± 500 psi] from the Commanded Fuel Rail Pressure?</p> <p>NO</p>	4I

STEP 4I: Check the fuel pressure relief valve for excessive leakage.

<p>Condition:</p> <ul style="list-style-type: none"> • Use the following procedure in the ISBe, ISB, and QSB (Common Rail Fuel System) Service Manual, Bulletin 4021271. Refer to Procedure 006-061 in Section 6. 		
Action	Specification/Repair	Next Step
<p>Measure the fuel pressure relief valve drain flow.</p> <p>Use the following procedure in the ISBe, ISB, and QSB (Common Rail Fuel System) Service Manual, Bulletin 4021271. Refer to Procedure 006-061 in Section 6.</p>	<p>Is the fuel pressure relief valve within specification?</p> <p>YES</p>	4J
	<p>Is the fuel pressure relief valve within specification?</p> <p>NO</p> <p>Repair:</p> <p>Replace the fuel pressure relief valve. Use the following procedure in the ISBe, ISB, and QSB (Common Rail Fuel System) Service Manual, Bulletin 4021271. Refer to Procedure 006-061 in Section 6.</p>	Repair complete

STEP 4J: Measure the high-pressure fuel supply pump fuel drain flow.

<p>Condition:</p> <ul style="list-style-type: none"> Use the following procedure in the ISBe, ISB, and QSB (Common Rail Fuel System) Service Manual, Bulletin 4021271. Refer to Procedure 005-016 in Section 5. 		
Action	Specification/Repair	Next Step
<p>Measure the high-pressure fuel supply pump return flow.</p> <p>Use the following procedure in the ISBe, ISB, and QSB (Common Rail Fuel System) Service Manual, Bulletin 4021271. Refer to Procedure 005-016 in Section 5.</p>	<p>Is the high-pressure fuel supply pump fuel drain flow greater than specification?</p> <p>YES</p> <p>Repair:</p> <p>Replace the high-pressure fuel supply pump. Use the following procedure in the ISBe, ISB, and QSB (Common Rail Fuel System) Service Manual, Bulletin 4021271. Refer to Procedure 005-016 in Section 5.</p>	<p>Repair complete</p>
	<p>Is the high-pressure fuel supply pump fuel drain flow greater than specification?</p> <p>NO</p>	<p>4K</p>

STEP 4K: Measure fuel drain line restriction.

<p>Condition:</p> <ul style="list-style-type: none"> Turn keyswitch OFF. Connect appropriate service tools to measure fuel drain line restriction. 		
Action	Specification/Repair	Next Step
<p>Measure the fuel inlet restriction.</p> <p>Use the following procedure in the ISBe, ISB, and QSB (Common Rail Fuel System) Service Manual, Bulletin 4021271. Refer to Procedure 006-012 in Section 6.</p> <p>Operate the engine at high idle:</p> <p>Maximum fuel drain line restriction: 0.19 bar [2.7 psi].</p>	<p>Is the drain line restriction less than specification?</p> <p>YES</p>	<p>Perform next troubleshooting procedure as outlined in Step 2.</p>
	<p>Is the drain line restriction less than specification?</p> <p>NO</p> <p>Repair:</p> <p>Check OEM fuel drain lines to tank for proper size, leaks, bends, clogs and fuel tank vents for plugging.</p>	<p>Repair Complete</p>

STEP 5: Air handling troubleshooting procedures.

STEP 5A: Check intake manifold pressure sensor accuracy.

<p>Condition:</p> <ul style="list-style-type: none"> • Turn keyswitch ON. • Connect INSITE™ electronic service tool. • Engine OFF. 		
Action	Specification/Repair	Next Step
<p>Monitor the reading for intake manifold pressure with the engine OFF.</p> <p>Start INSITE™ electronic service tool data monitor/logger and monitor the tool reading for intake manifold pressure with the engine OFF.</p>	<p>Intake manifold pressure reading is less than 102 mm-Hg [4 in-Hg]?</p> <p>YES</p> <p>Repair:</p> <p>N/A</p>	5B
	<p>Intake manifold pressure reading is less than 102 mm-Hg [4 in-Hg]?</p> <p>NO</p> <p>Repair:</p> <p>Replace the intake manifold pressure sensor. If equipped with a combination Intake Manifold Pressure/Temperature Sensor, use the following procedure in the ISB (4 cylinder) and ISBe (4 and 6 cylinder) Electronic Control System Troubleshooting and Repair manual, Bulletin 3666477. Refer to Procedure 019-159 in Section 19. Use the following procedure in the ISB, ISBe2, ISBe3, ISBe4, QSB4.5, QSB5.9, QSB6.7, ISC, QSC8.3, ISL, ISLe3, ISLe4, and QSL9 CM850 Electronic Control System Troubleshooting and Repair Manual, Bulletin 4021416. Refer to Procedure 019-159 in Section 19.</p>	Repair complete

STEP 5B: Check the Air intake System for Leaks.

<p>Condition:</p> <p>N/A</p>		
Action	Specification/Repair	Next Step
<p>Check the air intake system for leaks</p> <p>Use the following procedure in the ISBe, ISB, and QSB (Common Rail Fuel System) Service Manual, Bulletin 4021271. Refer to Procedure 010-024 in Section 10. On engines equipped with a turbocharged air compressor, one often overlooked item as a source for air leaks is the air compressor intake line. The intake line supplies intake air from the intake of the engine to the air compressor.</p>	<p>Were any air intake system leaks found?</p> <p>YES</p> <p>Repair:</p> <p>Repair or replace the damaged component.</p>	Repair complete
	<p>Were any air intake system leaks found?</p> <p>NO</p>	5C

STEP 5C: Check air intake restriction.

Condition:

- Turn keyswitch ON.
- Engine operating at rated speed and full load.

Action	Specification/Repair	Next Step
Check the air intake restriction by installing a vacuum gauge (Cummins® Part Number ST-1111-3) into the air intake system. Use the following procedure in the ISBe, ISB, and QSB (Common Rail Fuel System) Service Manual, Bulletin 4021271. Refer to Procedure 010-031 in Section 10. Maximum Air Intake Restriction: Dirty Filter 635 mm-H ₂ O; [25 in-H ₂ O] Clean Filter 254 mm-H ₂ O; [10 in-H ₂ O]	Is the air intake restriction greater than the specification? YES Repair: Correct the cause of high intake air restriction. Check for a plugged air filter or restricted air intake piping.	Repair Complete
	Is the air intake restriction greater than the specification? NO	5D

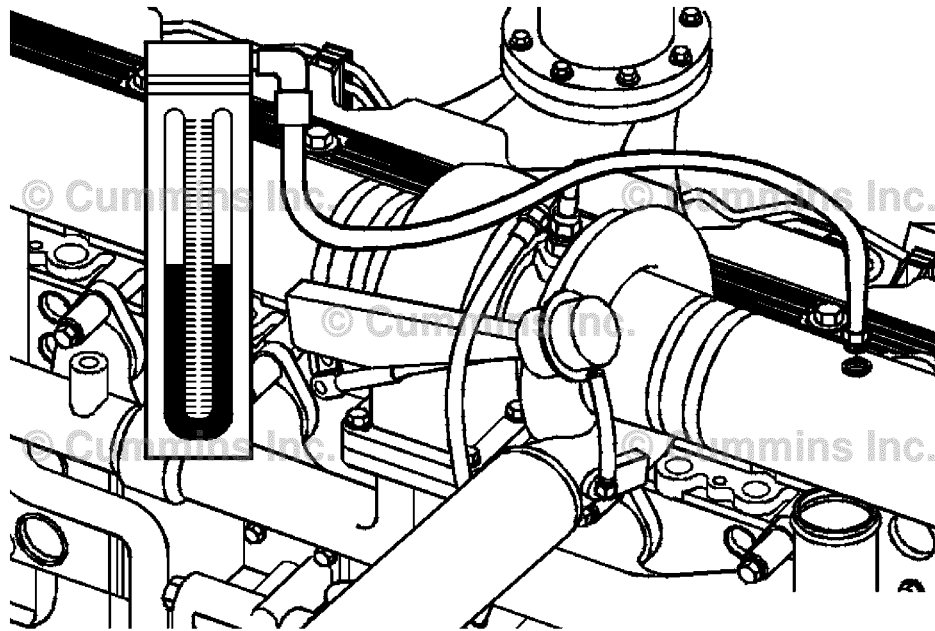

00d00109

STEP 5D: Inspect the turbocharger compressor blades for damage.

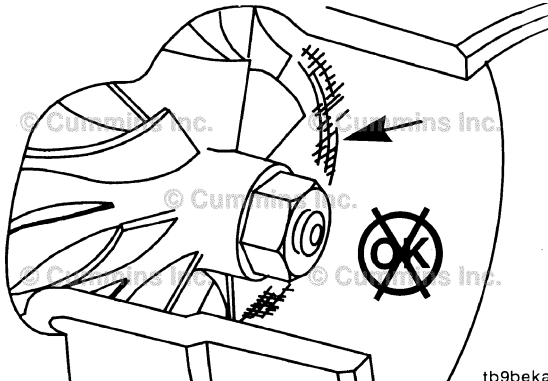
Condition: • Turn engine OFF. • Remove the intake piping from the turbocharger.		
Action	Specification/Repair	Next Step
Inspect the compressor blades for damage or wear. Service Manual, ISBe, ISB, and QSB (Common Rail Fuel System) Series Engines, Bulletin 4021271.	Damage found on turbocharger blades? YES Repair: Replace the turbocharger assembly. Use the following procedure in the ISBe, ISB, and QSB (Common Rail Fuel System) Service Manual, Bulletin 4021271. Refer to Procedure 010-033 in Section 10.	Repair Complete
	Damage found on turbocharger blades? NO	5E
		

STEP 5E: Determine if the turbocharger is a wastegated turbocharger.

Condition: N/A		
Action	Specification/Repair	Next Step
Determine if the turbocharger is a wastegated turbocharger. N/A	Is the turbocharger a wastegated turbocharger? YES	5F
	Is the turbocharger a wastegated turbocharger? NO	5H

STEP 5F: Inspect the wastegate actuator hose.

Condition:

- Turn keyswitch OFF.
- Remove the turbocharger if the wastegate actuator is inaccessible.

Action	Specification/Repair	Next Step
Inspect the integral wastegate actuator hose for cracks or holes. Use the following procedure in the ISBe, ISB, and QSB (Common Rail Fuel System) Service Manual, Bulletin 4021271. Refer to Procedure 010-050 in Section 10.	Holes or cracks found in the wastegate actuator hose? YES Repair: Replace the wastegate actuator hose. Use the following procedure in the ISBe, ISB, and QSB (Common Rail Fuel System) Service Manual, Bulletin 4021271. Refer to Procedure 010-050 in Section 10.	Repair complete
	Holes or cracks found in the wastegate actuator hose? NO	5G

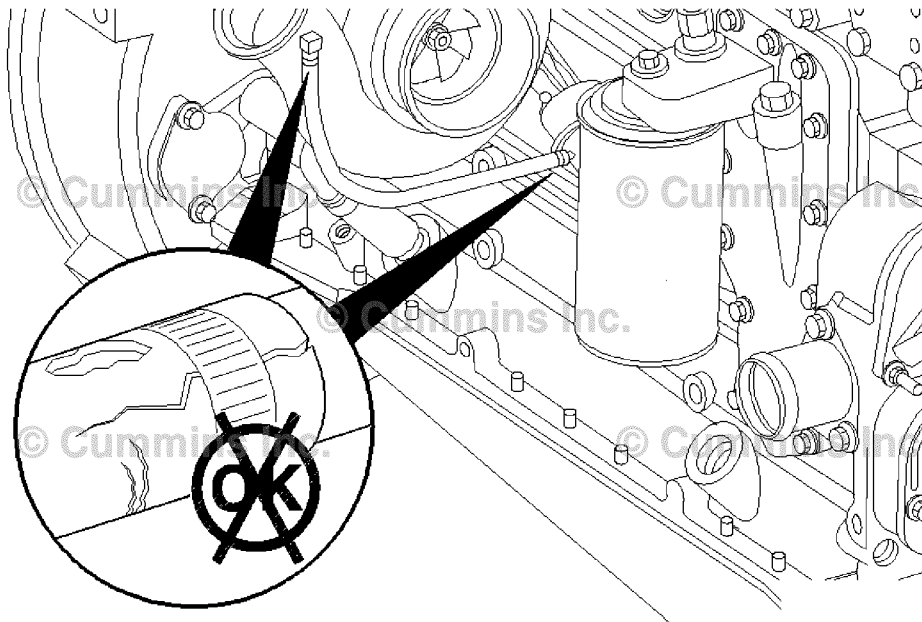

00d00107

STEP 5G: Inspect the turbocharger wastegate capsule for air leaks.

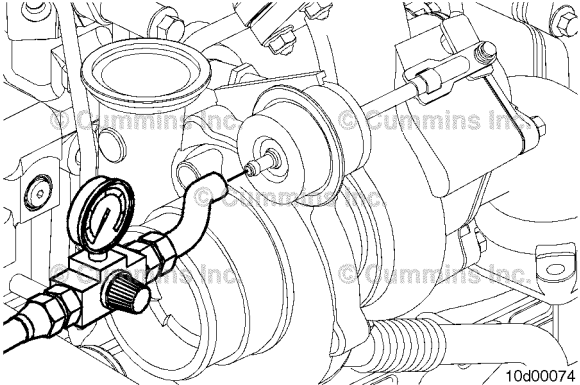
<p>Condition:</p> <ul style="list-style-type: none"> • Engine OFF. • Remove the wastegate actuator hose from the wastegate actuator. 		
Action	Specification/Repair	Next Step
<p>Perform a leak test on the wastegate actuator capsule.</p> <p>Use the following procedure in the ISBe, ISB, and QSB (Common Rail Fuel System) Service Manual, Bulletin 4021271. Refer to Procedure 010-050 in Section 10.</p> <p>Use Cummins® tool, Part Number 3823799, to apply a regulated air supply of 59 in-Hg (29 psi) to the wastegate actuator capsule. No air should be heard (i.e., leaking noise) through a functional wastegate capsule.</p>	<p>Did the wastegate actuator capsule leak air? YES</p> <p>Repair:</p> <p>Replace the wastegate actuator. Use the following procedure in the ISBe, ISB, and QSB (Common Rail Fuel System) Service Manual, Bulletin 4021271. Refer to Procedure 010-050 in Section 10.</p>	<p>Repair complete</p>
	<p>Did the wastegate actuator capsule leak air? NO</p>	<p>5G-1</p>
 <p>10d00074</p>		

STEP 5G-1: Inspect the turbocharger wastegate for proper operation.

Condition:

- Engine OFF.
- Remove the wastegate actuator hose from the wastegate actuator.

Action	Specification/Repair	Next Step
Check for wastegate actuator rod for movement. Use the following procedure in the ISBe, ISB, and QSB (Common Rail Fuel System) Service Manual, Bulletin 4021271. Refer to Procedure 010-050 in Section 10. Use Cummins® tool, Part Number 382379, to apply a regulated air supply of 59 in-Hg (29 psi) to the wastegate actuator capsule. Check for wastegate actuator rod for movement.	Did the wastegate actuator rod move? YES	5H
	Did the wastegate actuator rod move? NO	5G-2

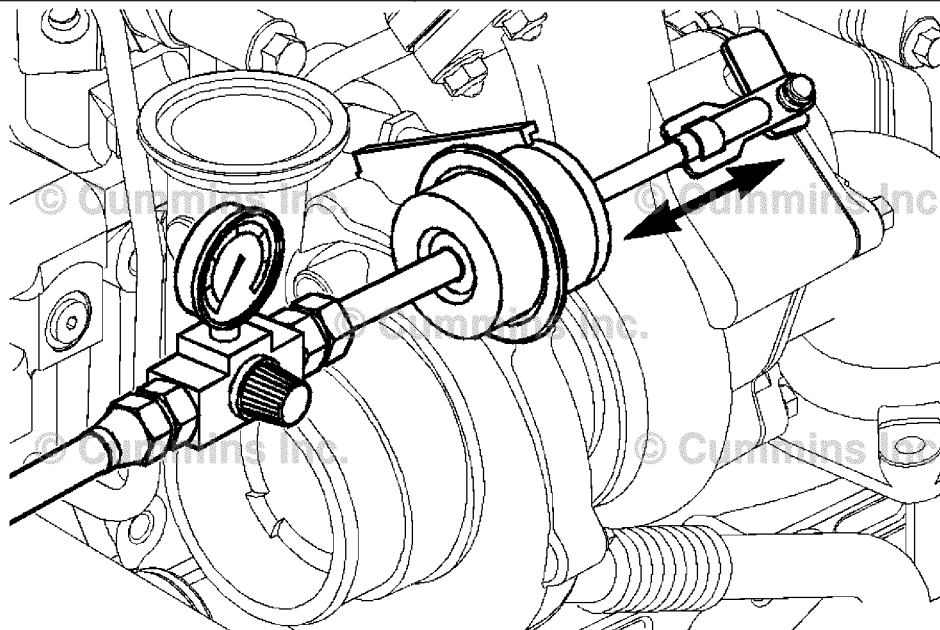

00d00106

STEP 5G-2: Inspect the turbocharger wastegate for proper operation.

Condition:

- Engine OFF.
- Remove the e-clip from the wastegate pin and disconnect the actuator rod from the wastegate lever.

Action	Specification/Repair	Next Step
<p>Check for wastegate actuator rod for movement with it disconnected from the turbocharger wastegate.</p> <p>Use the following procedure in the ISBe, ISB, and QSB (Common Rail Fuel System) Service Manual, Bulletin 4021271. Refer to Procedure 010-050 in Section 10.</p> <p>Use Cummins® Tool, Part Number 3823799, to apply a regulated air supply of 59 in-Hg (29 psi) to the wastegate actuator capsule. Check for wastegate actuator rod for movement.</p>	<p>Does the wastegate actuator rod move? YES</p> <p>Repair:</p> <p>Move the wastegate lever back and forth and check for smooth operation. If the wastegate lever does not move freely or binds, spray a penetrating oil on the wastegate lever joint and try to free the wastegate lever by working the lever back and forth. If the lever does not become free, then replace the turbocharger. Use the following procedure in the ISBe, ISB, and QSB (Common Rail Fuel System) Service Manual, Bulletin 4021271. Refer to Procedure 010-033 in Section 10.</p>	<p>Repair Complete</p>
	<p>Does the wastegate actuator rod move? NO</p> <p>Repair:</p> <p>Replace the wastegate actuator. Use the following procedure in the ISBe, ISB, and QSB (Common Rail Fuel System) Service Manual, Bulletin 4021271. Refer to Procedure 010-050 in Section 10.</p>	<p>Repair Complete</p>

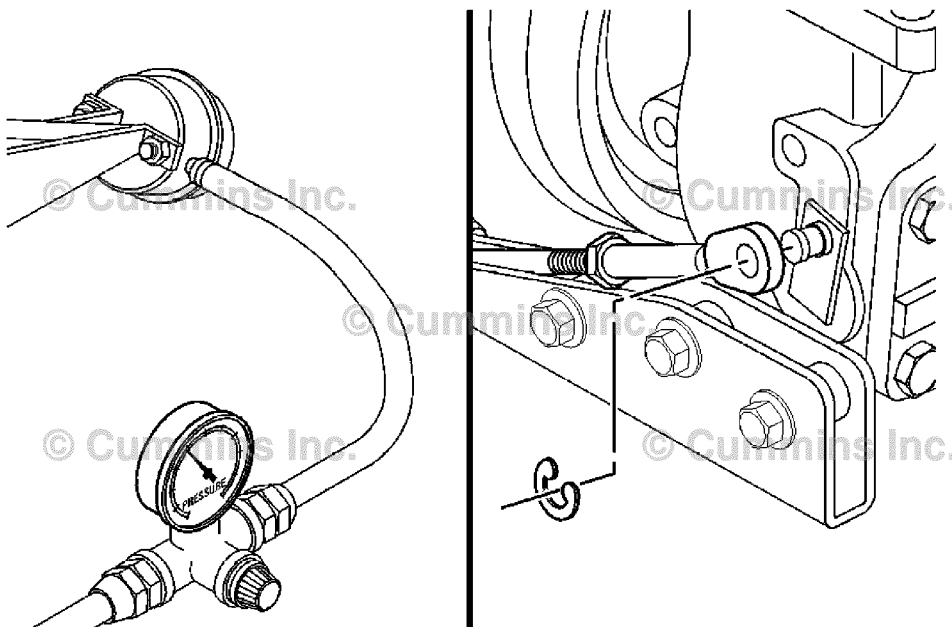

00d00108

STEP 5H: Measure turbocharger axial and radial clearance.

<p>Condition:</p> <ul style="list-style-type: none"> • Engine OFF. • Disconnect the exhaust and intake connections from the turbocharger. 		
Action	Specification/Repair	Next Step
<p>Follow the procedure for measuring the axial and radial clearances of the turbocharger.</p> <p>Use the following procedure in the Service Manual, ISB, ISBe, and QSB (Common Rail Fuel System) Series Engines, Bulletin 4021271. Refer to Procedure 010-033 in Section 10.</p> <p>See Clearance Specifications:</p>	<p>Are the axial and radial clearances within specification</p> <p>YES</p>	<p>5I</p>
	<p>Are the axial and radial clearances within specification?</p> <p>NO</p> <p>Repair:</p> <p>Replace the turbocharger assembly. Use the following procedure in the ISBe, ISB, and QSB (Common Rail Fuel System) Service Manual, Bulletin 4021271. Refer to Procedure 010-033 in Section 10.</p>	<p>Repair complete</p>

STEP 5I: Inspect charge-air cooler

Condition:

- Turn keyswitch OFF.

Action	Specification/Repair	Next Step
Inspect the charge air cooler for cleanliness, cracks, holes, or other damage. The pressure test and the temperature differential test in the Service Manual, ISBe, ISB, and QSB (Common Rail Fuel System) Series Engines, Bulletin 4021271, can be used to verify charge-air cooler problems. Refer to Procedure 010-027 in Section 10.	Does the charge-air cooler pass the visual inspection as well as the pressure test and temperature differential test? YES	Perform the next troubleshooting procedure as outlined in Step 2.
	Does the charge-air cooler pass the visual inspection as well as the pressure test and temperature differential test? NO Repair: Repair or replace the charge-air cooler assembly. Use the following procedure in the ISBe, ISB, and QSB (Common Rail Fuel System) Service Manual, Bulletin 4021271. Refer to Procedure 010-027 in Section 10.	Repair complete

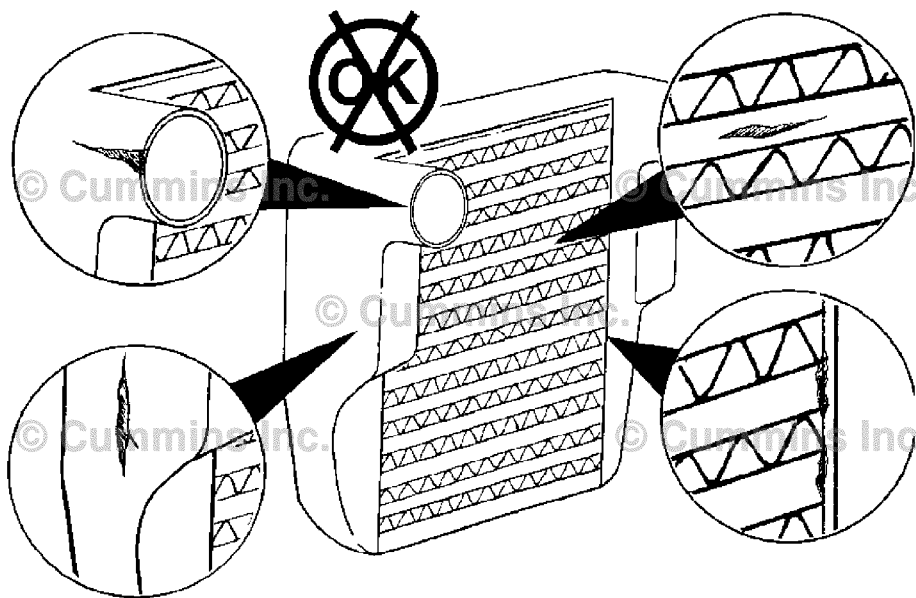

00d00112

STEP 6: Verify electronic features are operating correctly

STEP 6A: Verify accelerator (throttle) pedal travel.

<p>Condition:</p> <ul style="list-style-type: none"> • Turn keyswitch ON. • Connect INSITE™ electronic service tool. 		
Action	Specification/Repair	Next Step
<p>Monitor accelerator (throttle) position while fully depressing and releasing the throttle pedal Use INSITE™ electronic service tool.</p>	<p>Does the accelerator (throttle) position read 0 percent when the accelerator (throttle) is fully released and 100 percent when the accelerator (throttle) is fully depressed? YES</p>	6B
	<p>Does the accelerator (throttle) position read 0 percent when the accelerator (throttle) is fully released and 100 percent when the accelerator (throttle) is fully depressed? NO Repair: Refer to the OEM service manual for accelerator (throttle) pedal troubleshooting.</p>	Repair Complete

STEP 6B: Monitor the vehicle speed

<p>Condition:</p> <ul style="list-style-type: none"> • Turn keyswitch ON. • Connect INSITE™ electronic service tool. 		
Action	Specification/Repair	Next Step
<p>Monitor the vehicle speed while the vehicle is not moving • Use INSITE™ electronic service tool.</p>	<p>Does the vehicle speed read zero while the vehicle is not moving? YES</p>	6C
	<p>Does the vehicle speed read zero while the vehicle is not moving? NO Repair: Verify the VSS parameters are adjusted correctly in the ECM. Check the VSS and OEM harness.</p>	Repair complete

STEP 6C: Verify electronic feature settings are correct.

<p>Condition:</p> <ul style="list-style-type: none"> • Turn keyswitch ON. • Connect INSITE™ electronic service tool. 		
Action	Specification/Repair	Next Step
<p>Verify the following adjustable parameters are correctly set:</p> <p>Use INSITE™ electronic service tool to verify:</p> <ul style="list-style-type: none"> • Maximum vehicle speed • Powertrain protection • Rear axle ratio • Transmission tailshaft teeth • Tire revolutions per mile • Gear-down protection • Cruise control droop settings • Cruise control maximum vehicle speed • Accelerator type • Road speed governor • Vehicle acceleration management • Transmission type. 	<p>Are electronic features set correctly?</p> <p>YES</p>	6D
	<p>Are electronic features set correctly?</p> <p>NO</p> <p>Repair:</p> <p>Correct programmable features.</p>	Repair Complete

STEP 6D: Check temperature sensor accuracy.

<p>Condition:</p> <ul style="list-style-type: none"> • Turn keyswitch ON. • Connect INSITE™ electronic service tool. • The engine must be turned off long enough for engine coolant temperature to be equal to ambient air temperature. 		
Action	Specification/Repair	Next Step
<p>Monitor the following temperatures:</p> <p>Use INSITE™ electronic service tool to verify:</p> <ul style="list-style-type: none"> • Engine coolant temperature sensor • Intake manifold air temperature sensor • If equipped, the turbocharger compressor inlet air temperature sensor 	<p>Are all temperature readings within 5.6°C or 10°F of each other?</p> <p>YES</p>	6E
	<p>Are all temperature readings within 5.6°C or 10°F of each other?</p> <p>NO</p> <p>Repair:</p> <p>Check for a short from the signal pin of the temperature sensor in question to all other pins in the harness. Use the following procedure if no short is found, replace the temperature sensor that is reading higher or lower than the other sensors. Refer to Procedure 019-360 in Section 19. See Section 19 for specifications on each temperature sensor.</p>	Repair Complete

STEP 6E: Check ambient air pressure sensor accuracy.

<p>Condition:</p> <ul style="list-style-type: none"> • Turn keyswitch ON. • Connect INSITE™ electronic service tool. 		
Action	Specification/Repair	Next Step
<p>Start the INSITE™ electronic service tool data monitor/logger.</p> <p>Start INSITE™ electronic service tool data monitor/logger and compare INSITE™ electronic service tool reading for barometric air pressure to the local barometric pressure. Refer to Procedure 018-028 in Section 18.</p>	<p>INSITE™ electronic service tool reading is within 50.8 mm-Hg [2 in-Hg] of local barometric pressure?</p> <p>N/A</p> <p>YES</p>	<p>Perform the next troubleshooting procedure as outlined in Step 2.</p>
	<p>INSITE™ electronic service tool reading is within 50.8 mm-Hg [2 in-Hg] of local barometric pressure?</p> <p>NO</p> <p>Repair:</p> <p>Replace the barometric pressure sensor.</p>	<p>Repair complete</p>

STEP 7: Perform base engine mechanical checks.

STEP 7A: Verify overhead adjustments are correct.

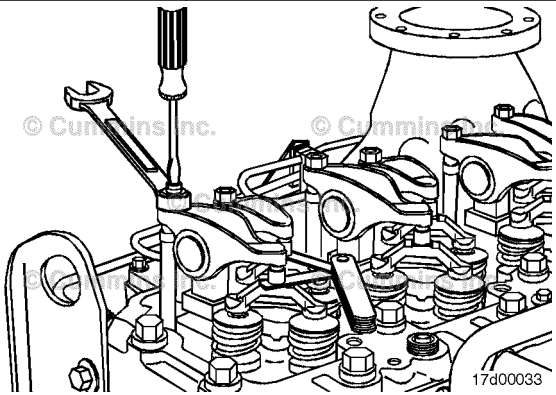
<p>Condition:</p> <ul style="list-style-type: none"> • Turn keyswitch ON. • Connect INSITE™ electronic service tool. 		
Action	Specification/Repair	Next Step
<p>Measure the overhead settings. Use the following procedure in the ISBe, ISB, and QSB (Common Rail Fuel System) Service Manual, Bulletin 4021271. Refer to Procedure 003-004 in Section 3.</p>	<p>Are the overhead settings within the lash check limits? YES</p>	<p>7B</p>
	<p>Are the overhead settings within the lash check limits? NO Repair: Adjust the overhead settings again. Use the following procedure in the ISBe, ISB, and QSB (Common Rail Fuel System) Service Manual, Bulletin 4021271. Refer to Procedure 003-004 in Section 3.</p>	<p>Repair complete</p>
		

STEP 7B: Check exhaust restriction.

Condition:

- Turn keyswitch ON.
- Engine operating at rated speed and full load.

Action	Specification/Repair	Next Step
Measure the exhaust system back pressure Measure the exhaust system back pressure by installing a pressure gauge, Part Number ST-1273, into the exhaust system immediately downstream of the turbocharger exhaust outlet. Maximum back pressure measured at the turbocharger outlet (exhaust manifold outlet for naturally aspirated engines) is: <ul style="list-style-type: none"> • 10 kPa (1.5 psi) • 15 kPa (2.2 psi). 	Is the exhaust back pressure greater than the specification? YES Repair: Correct the cause of high back pressure; look for collapsed or plugged exhaust pipes.	Repair Complete
	Is the exhaust back pressure greater than the specification? NO	7C

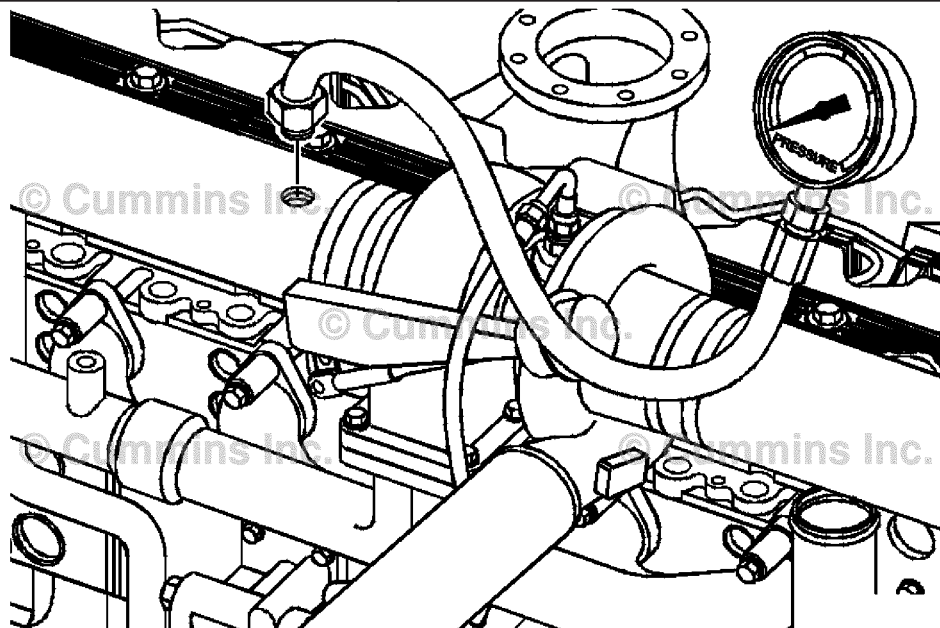

00d00110

STEP 7C: Verify engine crankcase pressure (blowby) is within specification

Condition:

- Turn keyswitch OFF.
- Connect appropriate service tools to measure blowby.

Action	Specification/Repair	Next Step
Measure engine crankcase pressure (blowby). Use the following procedure in the Troubleshooting and Repair Manual, ISBe, ISB, and QSB (Common Rail Fuel System) Series Engines, Bulletin 4021271. Refer to Procedure 014-010 in Section 14.	Is the engine crankcase pressure (blowby) less than specification? YES	7D
	Is the engine crankcase pressure (blowby) less than specification? NO Repair: See the Crankcase (Blowby) Excessive Troubleshooting Symptom (TS) tree.	See the Crankcase Gases (Blowby) Excessive Troubleshooting Symptom (TS) tree.

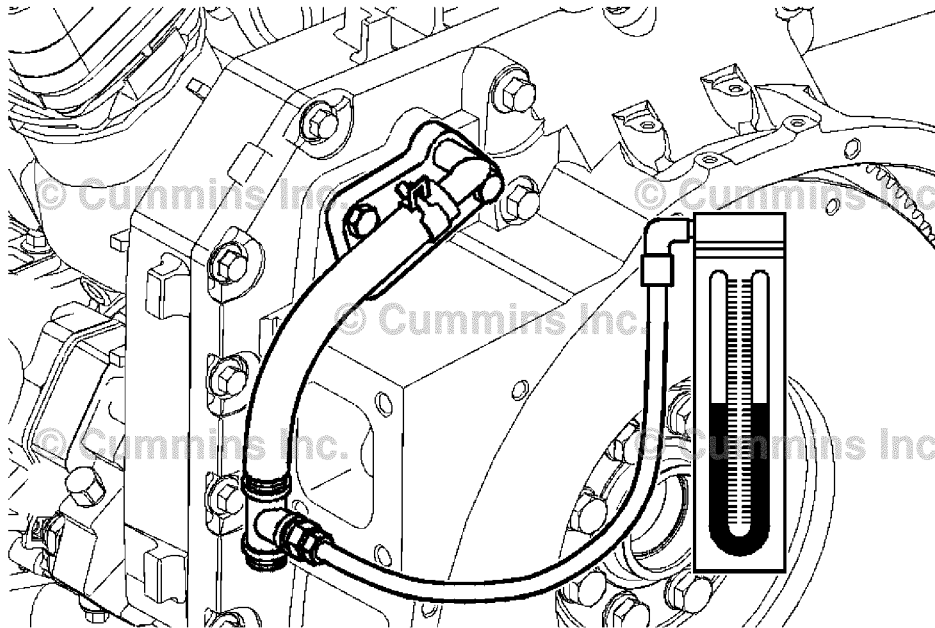

00d00111

STEP 7D: Check for internal engine damage.

<p>Condition:</p> <ul style="list-style-type: none"> • Turn keyswitch OFF. 		
Action	Specification/Repair	Next Step
<p>Remove the oil filter.</p> <p>Use the following procedures in the ISBe, ISB, and QSB (Common Rail Fuel System) Service Manual, Bulletin 4021271. Refer to Procedure 007-013 in Section 7.</p> <p>Refer to Procedure 007-083 in Section 7.</p> <p>Cut the oil filter open and inspect for debris and area of probable damage.</p>	<p>Did cutting the oil filter open reveal evidence of internal engine damage?</p> <p>YES</p> <p>Repair:</p> <p>Determine the area of probable damage and repair as necessary. Remove the lubricating oil pan and rocker lever cover, if necessary, to inspect for damage. Use the following procedures in the Service Manual, ISBe, ISB, and QSB (Common Rail Fuel System), Bulletin 4021271. Refer to Procedure 007-025 in Section 7. Refer to Procedure 003-011 in Section 3.</p>	<p>Repair Complete</p>
	<p>Did cutting the oil filter open reveal evidence of internal engine damage?</p> <p>NO</p>	<p>Perform the next troubleshooting procedure as outlined in Step 2.</p>

STEP 8: Excessive vibration checks

STEP 8A: Check engine idle speed

<p>Condition:</p> <ul style="list-style-type: none"> • Turn keyswitch ON. • Connect INSITE™ electronic service tool. • INSITE™ Monitor. 		
Action	Specification/Repair	Next Step
<p>Monitor the engine speed while the engine is idling.</p> <p>Use INSITE™ electronic service tool.</p> <p>See the engine dataplate for idle speed specifications.</p>	<p>Is the engine idle speed within specification?</p> <p>YES</p>	<p>8B</p>
	<p>Is the engine idle speed within specification?</p> <p>NO</p> <p>Repair:</p> <p>Adjust or increase the engine idle speed.</p>	<p>Repair Complete</p>

STEP 8B: Check if the feature Fast Idle Warm Up is available and enabled

Condition: <ul style="list-style-type: none"> • Turn keyswitch ON. • Connect INSITE™ electronic service tool. 		
Action	Specification/Repair	Next Step
Check the features and parameters and check if the feature Fast Idle Warm Up is available and enabled. <ul style="list-style-type: none"> • Turn keyswitch ON. • Connect INSITE™ electronic service tool. • INSITE™ Monitor. 	Is the feature Fast Idle Warm Up available and enabled? YES	8B-1
	Is the feature Fast Idle Warm Up available and enabled? NO	8C

STEP 8B-1: Monitor the Fast Idle Warm Up Status

Condition: <ul style="list-style-type: none"> • Turn keyswitch ON. • Connect INSITE™ electronic service tool. • INSITE™ Monitor. 		
Action	Specification/Repair	Next Step
Monitor Fast warm-up status Connect INSITE™ electronic service tool.	Is the feature Fast Idle Warm Up becoming active? YES Repair: Adjust the fast idle warm up idle speed or check with the customer on disabling the feature. Disabling the Fast Idle Warm Up feature can affect warranty.	Repair Complete
	Is the feature Fast Idle Warm Up becoming active? NO	8C

STEP 8C: Check front engine driven accessory(s)

<p>Condition:</p> <ul style="list-style-type: none"> • Turn keyswitch OFF. • Isolate front engine driven accessory(s). 		
Action	Specification/Repair	Next Step
Isolate front engine driven accessory(s) one at a time, including: <ul style="list-style-type: none"> • Alternator(s) • Refrigerant compressor(s) • Fan hub(s) • Hydraulic/Power steering pump(s) • Water pump • Cooling fan • Crankshaft driven PTO accessories. 	Did isolating the front engine driven accessory(s) correct the vibration? YES Repair: Repair or replace the malfunctioning component.	Repair Complete
	Did isolating the front engine driven accessory(s) correct the vibration? NO	8D

STEP 8D: Check the Vibration Damper/Crankshaft speed indicator ring.

<p>Condition:</p> <ul style="list-style-type: none"> • Turn keyswitch OFF. 		
Action	Specification/Repair	Next Step
Isolate front engine driven accessory(s) one at a time, including: Check the vibration damper/crankshaft speed indicator ring for damage. Use the following procedure for engines equipped with a rubber vibration damper in the Service Manual, ISBe, ISB, and QSB (Common Rail Fuel System) Series Engines, Bulletin 4021271. Refer to Procedure 001-051 in Section 1. Use the following procedure for engines equipped with a viscous damper in the Service Manual, ISBe, ISB, and QSB (Common Rail Fuel System) Series Engines, Bulletin 4021271. Refer to Procedure 001-052 in Section 1. Use the following procedure for engines equipped with a crankshaft speed indicator ring only in the Service Manual, ISBe, ISB, and QSB (Common Rail Fuel System) Series Engines, Bulletin 4021271. Refer to Procedure 001-071 in Section 1.	Is the vibration damper/crankshaft speed indicator ring damaged? YES Repair: Replace the damaged vibration damper/crankshaft speed indicator ring.	Repair Complete
	Is the vibration damper/crankshaft speed indicator ring damaged? NO	8E

STEP 8E: Check the engine support brackets, mounts and/or isolators.

Condition: • Turn keyswitch OFF.		
Action	Specification/Repair	Next Step
Check the engine support brackets, mounts and/or isolators for damage Use the following procedures for front and rear engine supports in the Service Manual, ISBe, ISB, and QSB (Common Rail Fuel System), Bulletin 4021271. Refer to Procedure 016-002 in Section 16. Refer to Procedure 016-003 in Section 16.	Are the engine support brackets, mounts, and/or isolators or damaged? YES Repair: Replace the damaged engine support brackets, mounts and/or isolators.	Repair Complete
	Are the engine support brackets, mounts, and/or isolators or damaged? NO	8F

STEP 8F: Check engine gear driven accessory(s).

Condition: • Turn keyswitch OFF.		
Action	Specification/Repair	Next Step
Check if the engine has an engine gear driven / air compressor driven hydraulic pump. N/A	Does the engine have an engine gear driven/ air compressor driven hydraulic pump? YES	8F-1
	Does the engine have an engine gear driven/ air compressor driven hydraulic pump? NO	8F-2

STEP 8F-1: Isolate engine gear driven accessory(s).

<p>Condition:</p> <ul style="list-style-type: none"> • Turn keyswitch OFF. • Isolate/remove the gear/air compressor driven hydraulic pump. 		
Action	Specification/Repair	Next Step
<p>Isolate/remove the gear driven air compressor driven hydraulic pump and operate the engine.</p> <p>Use the following procedure for general hydraulic pump remove and install instructions in the Service Manual, ISBe, ISB, and QSB (Common Rail Fuel System) Series Engines, Bulletin 4021271. Refer to Procedure 009-016 in Section 9.</p> <p>Some engines require an accessory drive to drive the hydraulic pump. It could be necessary to isolate this as well. Use the following procedure to isolate the accessory drive in the Service Manual, ISBe, ISB, and QSB (Common Rail Fuel System) in Series Engines, Bulletin 4021271. Refer to Procedure 009-001 in Section 9</p>	<p>Did isolating/removing engine gear driven/air compressor driven hydraulic pump correct the vibration?</p> <p>YES</p> <p>Repair:</p> <p>Repair or replace the damaged component.</p>	<p>Repair Complete</p>
	<p>Did isolating/removing engine gear driven/air compressor driven hydraulic pump correct the vibration?</p> <p>NO</p>	<p>8F-2</p>

STEP 8F-2: Check if the engine is equipped with an air compressor.

<p>Condition:</p> <ul style="list-style-type: none"> • Turn keyswitch OFF. 		
Action	Specification/Repair	Next Step
<p>Check if the engine is equipped with an engine gear driven air compressor.</p>	<p>Is the engine equipped with an engine gear driven air compressor?</p> <p>YES</p>	<p>8F-3</p>
	<p>Is the engine equipped with an engine gear driven air compressor?</p> <p>NO</p>	<p>8G</p>

STEP 8F-3: Unload the air compressor and operate.

<p>Condition:</p> <ul style="list-style-type: none"> • Turn keyswitch OFF. • Unload the air compressor. 		
Action	Specification/Repair	Next Step
<p>With the air compressor unloaded, operate the engine in the condition in which the vibration complaint occurs.</p> <p>The air compressor can be unloaded by:</p> <ol style="list-style-type: none"> 1. Disconnecting the air governor signal line and connecting regulated shop air, with a pressure gauge, to the air compressor governor air signal port. 2. Disconnecting the air compressor discharge line and air intake hose from the air compressor. <p>Typically 621 kPa (90 psi) of air pressure is the set point for unloading the air compressor. See the OEM service manual.</p> <p>On turbocharged air compressors, make sure to plug the air intake hose attached to the intake manifold.</p>	<p>Did unloading the air compressor significantly reduce or eliminate the vibration?</p> <p>YES</p>	8F-4
	<p>Did unloading the air compressor significantly reduce or eliminate the vibration?</p> <p>NO</p>	8G

STEP 8F-4: Check the air compressor timing.

<p>Condition:</p> <ul style="list-style-type: none"> • Turn keyswitch OFF. • Check the timing of the air compressor. 		
Action	Specification/Repair	Next Step
<p>The air compressor is not required to be timed to the 3.9 L and 5.9 L engines.</p> <p>Check that the air compressor is correctly timed to the engine.</p> <p>Use the following procedure in the ISBe, ISB, and QSB (Common Rail Fuel System) Service Manual, Bulletin 4021271. Refer to Procedure 012-014 in Section 12.</p> <p>When troubleshooting a vibration issue in which it is suspected that the air compressor is the cause of the vibration, it may be necessary to isolate the air compressor from the engine.</p>	<p>Was the air compressor correctly timed to the engine?</p> <p>YES</p> <p>Repair:</p> <p>Replace the air compressor. Use the following procedure in the ISBe, ISB, and QSB (Common Rail Fuel System) Service Manual, Bulletin 4021271. Refer to Procedure 012-014 in Section 12.</p>	Repair Complete
	<p>Was the air compressor correctly timed to the engine?</p> <p>NO</p> <p>Repair:</p> <p>Correctly time the air compressor to the engine. Use the following procedure in the ISBe, ISB, and QSB (Common Rail Fuel System) Service Manual, Bulletin 4021271. Refer to Procedure 012-014 in Section 12.</p>	Repair Complete

STEP 8G: Check/isolate the engine driven components.

<p>Condition:</p> <ul style="list-style-type: none"> • Turn keyswitch OFF. • Isolate/remove any engine driven components. 		
Action	Specification/Repair	Next Step
<p>Isolate/remove any engine driven components and operate the engine.</p> <p>Engine driven components include:</p> <ul style="list-style-type: none"> • Transmissions (Torque converters/Clutches) • Hydraulic pumps • Direct drive shafts • Flywheels. Refer to Procedure 016-005 in Section 16 of the Service Manual, ISBe, ISB, and QSB (Common Rail Fuel System) Series Engines, Bulletin 4021271. • Flexplates. Refer to Procedure 016-004 in Section 16 of the Service Manual, ISBe, ISB, and QSB (Common Rail Fuel System) Series Engines, Bulletin 4021271. 	<p>Did isolating/removing any engine driven component correct the vibration?</p> <p>YES</p> <p>Repair:</p> <p>Replace the malfunctioning component. Refer to the OEM service manual.</p>	<p>Repair Complete</p>
	<p>Did isolating/removing any engine driven component correct the vibration?</p> <p>NO</p>	<p>8H</p>

STEP 8H: Check the flywheel housing alignment.

<p>Condition:</p> <ul style="list-style-type: none"> • Turn keyswitch OFF. • Engine driven components removed. 		
Action	Specification/Repair	Next Step
<p>Measure the flywheel housing bore and face runout.</p> <p>Use the following procedure in the ISBe, ISB, and QSB (Common Rail Fuel System) Service Manual, Bulletin 4021271. Refer to Procedure 016-006 in Section 16.</p>	<p>Is the flywheel housing bore and face runout within specification?</p> <p>YES</p>	<p>8I</p>
	<p>Is the flywheel housing bore and face runout within specification?</p> <p>NO</p> <p>Repair:</p> <p>Use the following procedure for flywheel housing repair options in the Service Manual, ISBe, ISB, and QSB (Common Rail Fuel System) Series Engines, Bulletin 4021271. Refer to Procedure 016-006 in Section 16.</p>	<p>Repair Complete</p>

STEP 8I: Check if engine is equipped with an internal engine balancer.

Condition: <ul style="list-style-type: none"> • Turn keyswitch OFF. 		
Action	Specification/Repair	Next Step
Check if engine is equipped with an internal engine balancer. Use the engine serial number to look up the engine build history to see if the engine was built with an internal engine balancer option. Only 4 cylinder engines can be equipped with an internal engine balancer.	Is the engine equipped with an internal engine balancer? YES	8I-1
	Is the engine equipped with an internal engine balancer? NO	8A

STEP 8I-1: Check the internal engine balancer.

Condition: <ul style="list-style-type: none"> • Turn keyswitch OFF • Lubricating oil pan removed 		
Action	Specification/Repair	Next Step
Remove the lubricating oil pan and inspect the internal engine balancer. Use the following procedure in the ISBe, ISB, and QSB (Common Rail Fuel System) Service Manual, Bulletin 4021271. Refer to Procedure 007-025 in Section 7 Check to make sure the internal engine balancer is correctly timed to the engine. Check for any damage to the internal engine balancer. Only 4 cylinder engines can be equipped with an internal engine balancer.	Is the internal engine balancer timing incorrect or is the balancer damaged? YES Repair: Repair or replace the internal engine balancer.	Repair Complete
	Is the internal engine balancer timing incorrect or is the balancer damaged? NO	7A

Engine Performance Troubleshooting Tree for QSB5.9 Marine Engines with CM850 Electronic Control System

This troubleshooting procedure should be followed for the following symptoms:

- Engine Acceleration or Response Poor
- Cranking Fuel Pressure is Low
- Engine Operating Fuel Pressure is Low
- Engine Decelerates Slowly
- Engine Difficult to Start or Will Not Start (Exhaust Smoke)
- Engine Difficult to Start or Will Not Start (No Exhaust Smoke)
- Engine Power Output Low
- Engine Runs Rough at Idle
- Engine Runs Rough or Misfires
- Engine Speed Surges at Low or High Idle
- Engine Speed Surges Under Load or in Operating Range
- Smoke, Black - Excessive
- Smoke, White - Excessive
- Engine Shuts Off or Dies Unexpectedly or Dies During Deceleration
- Engine Starts But Will Not Keep Running
- Engine Will Not Reach Rated Speed (rpm)
- Intake Manifold Pressure (Boost) is Below Normal
- Excessive Vibration in Marine Applications

How to Use This Troubleshooting Procedure:

This symptom tree can be used to troubleshoot all performance based symptoms listed above. Start by performing Step 1 troubleshooting. Step 2 will ask a series of questions and will provide a list of troubleshooting steps to perform, depending on the symptom. Perform the list of troubleshooting in the sequence shown in the Specifications/Repair section of the tree.

Shop Talk:

Operational is a term that in general describes vessel performance on the water. Operational problems for an engine can be caused by several different factors. Some of the factors are engine-related and some are **not**. Before troubleshooting, it is important to determine the exact complaint and whether the engine has a real operational problem or if it simply does **not** meet owner expectations.

Low power is a term that is used in the field to describe many different performance problems. Low power is defined as the inability of the engine to produce the power necessary to move the vessel at a speed that can be reasonably expected under the given environment.

Poor acceleration or response is described as the inability of the vessel to accelerate satisfactorily from a stop. It can also be the lag in acceleration at conditions less than rated speed and load. Poor acceleration or response is difficult to troubleshoot, since it can be caused by several factors.

TROUBLESHOOTING SUMMARY

STEPS	SPECIFICATIONS	SRT CODE
STEP 1: Perform basic troubleshooting procedures.		
STEP 1A: Check for active fault codes or high counts of inactive fault codes.	Active fault codes or high counts of inactive fault codes?	
STEP 1B: Perform basic troubleshooting checks.	Can the problem be verified?	
STEP 1C: Perform basic troubleshooting checks.	All steps have been verified to be correct?	
STEP 2: Determination of engine symptom.		
STEP 2A: Low power, poor acceleration, or poor response.	Is the engine symptom low power, poor acceleration, or poor response?	
STEP 2B: Engine misfire, engine speed surge, or engine speed unstable.	Is the engine symptom engine misfire, engine speed surge, or engine speed unstable?	
STEP 2C: Excessive white or black smoke.	Is the engine symptom excessive white or black smoke?	
STEP 2D: Low intake manifold pressure.	Is the engine symptom low boost pressure?	
STEP 2E: Engine will not start or difficult to start, engine shuts off unexpectedly.	Is the engine symptom engine will not start or difficult to start, engine shuts off unexpectedly?	
STEP 2F: Engine vibration excessive.	Is the symptom engine vibration is excessive occurring when the engine is in or out of gear?	
STEP 3: Engine starting and running troubleshooting procedures.		
STEP 3A: Verify the fuel supply and return valves are open.	Are the fuel supply and return valves in the open position?	
STEP 3A-1: Check the fuel cooler for damage due to high fuel return back pressure.	Is the fuel cooler damaged or collapsed internally?	
STEP 3B: Verify the low pressure fuel lines are routed correctly.	Are the low pressure fuel lines connected properly to the engine control module (ECM) cooling plate?	
STEP 3C: Check the engine speed during cranking.	Is the engine cranking speed greater than 150 rpm?	
STEP 3D: Check the ECM keyswitch voltage.	Is the keyswitch voltage equal to the battery voltage?	
STEP 3E: Check the ECM battery supply voltage.	Is the ECM battery supply voltage equal to the battery voltage?	
STEP 3F: Verify the rail fuel pressure sensor accuracy.	Is the rail fuel pressure sensor (measured) value less than 30 bar [435 psi]?	

STEP 3G: Check for fuel rail pressure while cranking the engine.

Did Fault Code 2215 or Fault Code 559 become active during the failed start attempt?

STEP 3H: Check the fuel lift pump pressure.

Is the fuel lift pump pressure greater than the specifications outlined in Procedure 005-045?

STEP 4: Fuel system troubleshooting procedures.

STEP 4A: Check for fault codes that pertain to the fuel system.

Did Fault Code 2215 or Fault Code 559 become active during the failed start attempt?

STEP 4B: Check for air in the high pressure pump fuel supply.

Is air present in the fuel supply?

STEP 4C: Measure the fuel inlet restriction.

Is the fuel inlet restriction above specification?

STEP 4D: Perform the single cylinder cutout test.

Can the miss or excessive smoke be attributed to a single cylinder?

STEP 4E: Perform the cylinder balance diagnostic test.

Does the cylinder performance test identify any cylinder that is contributing to a power imbalance?

STEP 4F: Measure the fuel drain line restriction.

Is the fuel drain line restriction within specification?

STEP 5: Air handling troubleshooting procedures.

STEP 5A: Check the intake manifold pressure sensor accuracy.

Is the reading within 50.8 mm-Hg [2 in-Hg] of local barometric pressure?

STEP 5B: Check the air intake system for leaks.

Were any air intake system leaks found?

STEP 5C: Check the air intake restriction.

Is the air intake restriction greater than the specification?

STEP 5D: Inspect the turbocharger blades for damage.

Are the turbocharger blades damaged?

STEP 5E: Determine if the turbocharger is a wastegated turbocharger.

Is the turbocharger a wastegated turbocharger?

STEP 5F: Inspect the wastegate actuator hose.

Are holes or cracks found in the wastegate actuator hose?

STEP 5G: Inspect the turbocharger wastegate capsule for air leaks.

Did the wastegate actuator rod move?

STEP 5G-1: Inspect the turbocharger wastegate for proper operation.

Did the wastegate actuator rod move?

STEP 5G-2: Inspect the turbocharger wastegate for proper operation.

Does the wastegate actuator rod move?

STEP 5H: Measure turbocharger axial and radial clearance.

Are the axial and radial clearances within specification?

STEP 5I: Inspect the aftercooler.

Is the aftercooler free of cracks or other damage?

STEP 6: Electronic feature troubleshooting procedures.

STEP 6A:	Verify the throttle travel.	Does the throttle position read 0 when the throttle is released and 100 percent when the throttle is actuated?
STEP 6B:	Check the ambient air pressure sensor accuracy.	Is the reading within 101.6 mm-Hg [4 in-Hg] of local barometric pressure?
STEP 6C:	Check the intake manifold pressure sensor accuracy.	Is the reading within 101.6 mm-Hg [4 in-Hg] of local barometric pressure?
STEP 7:	Base engine troubleshooting procedures.	
STEP 7A:	Verify the overhead adjustments are correct.	Are the overhead settings within the reset limits?
STEP 7B:	Check the exhaust restriction.	Is the exhaust system back pressure less than 127 mm-Hg [5 in-Hg] or 1763 mm-H ₂ O [68 in-H ₂ O] or 17 kPa [2.5 psi]?
STEP 7C:	Check the engine blowby.	Are the engine blowby measurements within specification?
STEP 7C-1:	Verify turbocharger contribution to engine blowby.	Has the total engine blowby dropped more than 30 percent of the total?
STEP 8:	Excessive vibration troubleshooting procedures.	
STEP 8A:	Check the gear ratio and propeller configuration.	Are the gear ratio and the propeller incorrectly matched to the engine power?
STEP 8B:	Check for correct engine mounting isolators and for proper installation requirements.	Are the engine mount isolators correct and installed correctly?
STEP 8C:	Check for damaged engine mounts and isolators.	Are the engine mounts and isolators in good condition?
STEP 8D:	Check the exhaust system.	Is the exhaust system deficient?
STEP 8E:	Check the engine driven accessories.	Is an engine driven accessory malfunctioning?
STEP 8F:	Check the shaft coupling to gear coupling alignment.	Is the shaft coupling to gear coupling misaligned?
STEP 8G:	Check the propeller shaft for proper installation.	Is the propeller shaft installed correctly?
STEP 8H:	Check the propeller shaft for straightness.	Is the propeller shaft straightness within the OEM specification?
STEP 8I:	Isolate the engine.	Does the engine vibration persist?
STEP 8J:	Check for strut/cutlass bearing misalignment.	Is the strut/cutlass bearing misaligned or strut mounting not secure?
STEP 8K:	Check the propeller.	Is the propeller out of balance or not fitted properly to the shaft?

- | | | |
|------------------------|---|---|
| <u>STEP 8L:</u> | Check the V-angle on the V-strut. | Does the V-angle on the V-strut match the angle of the blade on the prop? |
| <u>STEP 8M:</u> | Check the propeller tunnels. | Does the entry and exit of the propeller tunnel match with the propeller blades? |
| <u>STEP 8N:</u> | Check the engine to transmission torsional coupling. | Is the torsional coupling incorrect or worn? |
| <u>STEP 8O:</u> | Check the rudder. | Does the rudder have excessive in the rudder post? |
| <u>STEP 8P:</u> | Check the engine flywheel housing to cylinder block alignment. | Is the flywheel housing alignment incorrect? |

TROUBLESHOOTING STEP

STEP 1: Perform basic troubleshooting procedures.

STEP 1A: Check for active fault codes or high counts of inactive fault codes.

Condition: <ul style="list-style-type: none"> • Connect INSITE™ electronic service tool. • Turn keyswitch ON. 		
Action	Specification/Repair	Next Step
Check for any active fault codes. <ul style="list-style-type: none"> • Use INSITE™ electronic service tool to read the fault codes. 	Active fault codes or high counts of inactive fault codes? YES Repair: Reference Section TF in the ISB, ISBe4, QSB4.5, QSB5.9, QSB6.7, ISC, QSC8.3, ISL, ISLe3 and QSL9 (Common Rail Fuel System) Series Engines, CM850 Electronic Control System Troubleshooting and Repair Manual, Bulletin 4021416 for fault code troubleshooting.	Repair complete
	Active fault codes or high counts of inactive fault codes? NO	1B

STEP 1B: Perform basic troubleshooting checks.

Condition: None		
Action	Specification/Repair	Next Step
Verify the following items. <ul style="list-style-type: none"> • Is the engine operating within the conditions it was intended to perform? For example, wide open throttle rpm, ambient versus engine room temperatures, load on the vessel, sea conditions, etc. • Are the customer's expectations in line with the engine capability? • Is the engine performing according to the OEM sea trial? 	Can the problem be verified? YES	1C
	Can the problem be verified? NO Repair: The problem can not be verified and no repair is possible.	Repair complete

STEP 1C: Perform the basic troubleshooting checks.

Condition: None		
Action	Specification/Repair	Next Step
The following items must be checked or verified before continuing. <ul style="list-style-type: none"> • Verify the fuel level in the tanks. • Verify there have not been any changes to the control parts list (turbocharger, injectors, pistons, fuel pump, camshaft, etc.) components on the engine. • Verify the fuel grade is correct for the application. • Verify the engine is operating within the recommended altitude. • Verify the engine oil is at the correct level. • Verify none of the air vents are restricted or obstructed. • Verify the engine parasitics have not changed. • Verify the engine duty cycle has not changed. • Verify the engine cranking speed is greater than 150 rpm. • Verify the battery voltage is adequate. • Verify the drive train is correctly matched to the engine. • Verify the transmission is correct and is not malfunctioning. • Verify the propeller is at the correct pitch and is not damaged. • Verify the fuel inlet temperature to the fuel pump is within specification. • Verify the engine throttle and throttle wiring is correct for the engine response issues. • Verify the condition of the hull (clean and no damage). 	All steps have been verified to be correct? YES	2A
	All steps have been verified to be correct? NO Repair: Correct the condition and verify the complaint is no longer present after the repair.	Repair complete

STEP 2: Determination of engine symptom.

STEP 2A: Low power, poor acceleration, or poor response.

Condition: None		
Action	Specification/Repair	Next Step
Determine the engine symptom according to the engine performance. N/A	Is the engine symptom low power, poor acceleration, or poor response? YES Repair: Perform the troubleshooting steps in the recommended order listed below. <ul style="list-style-type: none"> • Fuel System Checks • Air Handling Checks • Electronics Checks • Base Engine Checks 	Perform the troubleshooting steps suggested in the repair procedure.
	Is the engine symptom low power, poor acceleration, or poor response? NO	2B

STEP 2B: Engine misfire, engine speed surge, or engine speed unstable.

Condition: None		
Action	Specification/Repair	Next Step
Determine the engine symptom according to the engine performance. N/A	Is the engine symptom engine misfire, engine speed surge, or engine speed unstable? YES Repair: Perform the troubleshooting steps in the recommended order listed below. <ul style="list-style-type: none"> • Fuel System Checks • Air Handling Checks • Electronics Checks 	Perform the troubleshooting steps suggested in the repair procedure.
	Is the engine symptom engine misfire, engine speed surge, or engine speed unstable? NO	2C

STEP 2C: Excessive white or black smoke.

Condition: None		
Action	Specification/Repair	Next Step
Determine the engine symptom according to the engine performance. N/A	Is the engine symptom excessive white or black smoke? YES Repair: Perform the troubleshooting steps in the recommended order listed below. <ul style="list-style-type: none"> • Air Handling Checks • Fuel System Checks 	Perform the troubleshooting steps suggested in the repair procedure.
	Is the engine symptom excessive white or black smoke? NO	2D

STEP 2D: Low intake manifold pressure.

Condition: None		
Action	Specification/Repair	Next Step
Determine the engine symptom according to the engine performance. N/A	Is the engine symptom low boost pressure? YES Repair: Perform the troubleshooting steps in the recommended order listed below. <ul style="list-style-type: none"> • Air Handling Checks • Fuel System Checks • Base Engine Checks 	Perform the troubleshooting steps suggested in the repair procedure.
	Is the engine symptom low boost pressure? NO	2E

STEP 2E: Engine will not start or difficult to start, engine shuts off unexpectedly.

Condition: None		
Action	Specification/Repair	Next Step
Determine the engine symptom according to the engine performance. N/A	Is the engine symptom engine will not start or difficult to start, engine shuts off unexpectedly? YES Repair: Perform the troubleshooting steps in the recommended order listed below. <ul style="list-style-type: none"> • No Start Checks • Fuel System checks • Air Handling Checks • Electronics Checks 	Perform the troubleshooting steps suggested in the repair procedure.
	Is the engine symptom engine will not start or difficult to start, engine shuts off unexpectedly? NO	2F

STEP 2F: Engine vibration excessive.

Condition: None		
Action	Specification/Repair	Next Step
Determine the engine symptom according to the engine performance. N/A	Is the symptom engine vibration is excessive occurring when the engine is in or out of gear? YES Repair: Perform the troubleshooting steps in the recommended order listed below. <ul style="list-style-type: none"> • Fuel System Checks • Air Handling Checks • Electronics Checks • Base Engine Checks • Excessive Vibration Checks 	Perform the troubleshooting steps suggested in the repair procedure.
	Is the symptom engine vibration is excessive occurring when the engine is in or out of gear? NO	Return to the correct symptom tree.

STEP 3: Engine starting and running troubleshooting procedures.

STEP 3A: Verify the fuel supply and return valves are open.

Condition: • Turn keyswitch OFF.		
Action	Specification/Repair	Next Step
Verify the fuel supply and return valves are in the open position. If the vessel is new or work has been completed on the vessel, the fuel valves could have been left in the OFF position.	Is the fuel supply and return valves in the open position? YES	3B
	Is the fuel supply and return valves in the open position? NO Repair: Turn the fuel supply and return valve to the OPEN position and verify that no engine damage has occurred.	3A-1

STEP 3A-1: Check the fuel cooler for damage due to high fuel return back pressure.

Condition: None		
Action	Specification/Repair	Next Step
Remove and inspect the fuel cooler. Check the fuel cooler for internal damage, or collapse. Refer to Procedure 006-062 in Section 6 in the ISB, ISBe, ISBe4, QSB4.5, QSB5.9, and QSB6.7 (Common Rail Fuel System) Series Engines Service Manual, Bulletin 4021271.	Is the fuel cooler damaged or collapsed internally? YES Repair: Remove and replace the fuel cooler. Refer to Procedure 006-062 in Section 6 in the ISB, ISBe, ISBe4, QSB4.5, QSB5.9, and QSB6.7 (Common Rail Fuel System) Series Engines Service Manual, Bulletin 4021271.	Repair complete
	Is the fuel cooler damaged or collapsed internally? NO	3B

STEP 3B: Verify the low pressure fuel lines are routed correctly.

Condition: None		
Action	Specification/Repair	Next Step
It is sometimes possible to get the low pressure fuel lines connected to the ECM cooling plate installed improperly. The top connection to the ECM cooling plate is the inlet and the bottom connection is the outlet. Verify these connections are correct if the low pressure fuel lines have been removed and reinstalled on the engine.	Are the low pressure fuel lines connected properly to the ECM cooling plate? YES	3C
	Are the low pressure fuel lines connected properly to the ECM cooling plate? NO Repair: Properly connect the low pressure fuel lines to the ECM cooling plate. The fuel inlet is the top connection.	Repair complete

STEP 3C: Check the engine speed during cranking.

Condition:		
<ul style="list-style-type: none"> • Connect INSITE™ electronic service tool. • Turn keyswitch ON. 		
Action	Specification/Repair	Next Step
Use INSITE™ electronic service tool to monitor Engine Speed while cranking the engine. If the engine does not crank at all, see the troubleshooting symptom tree Engine Will Not Crank or Cranks Slowly.	Is the engine cranking speed greater than 150 rpm? YES	3D
	Is the engine cranking speed greater than 150 rpm? NO Repair: Find and correct the cause for low cranking speed. Check the batteries, engine starting motor and accessory loads. See the troubleshooting symptom tree Engine Will Not Crank or Cranks Slowly.	Repair complete

STEP 3D: Check the engine control module (ECM) keyswitch voltage.

<p>Condition:</p> <ul style="list-style-type: none"> • Turn keyswitch OFF. • Disconnect the OEM harness from the ECM. • Turn keyswitch ON. 		
Action	Specification/Repair	Next Step
<p>Measure the signal voltage.</p> <ul style="list-style-type: none"> • Measure the signal voltage from the keyswitch input SIGNAL wire of the OEM harness to the engine block ground. 	<p>Is the keyswitch voltage equal to the battery voltage?</p> <p>YES</p>	3E
<p>Measure the keyswitch voltage with the keyswitch in the ON position and also with the keyswitch in the Cranking position.</p> <p>Refer to the wiring diagram for connector pin identification.</p>	<p>Is the keyswitch voltage equal to the battery voltage?</p> <p>NO</p> <p>Repair:</p> <p>Repair or replace the keyswitch harness, keyswitch, or check the battery connections.</p> <p>The keyswitch harness can be supplied by the OEM.</p>	Repair complete

STEP 3E: Check the ECM battery supply voltage.

<p>Condition:</p> <ul style="list-style-type: none"> • Turn the keyswitch OFF. • Disconnect the ECM power harness from the ECM. 		
Action	Specification/Repair	Next Step
<p>Measure the voltage.</p> <ul style="list-style-type: none"> • Measure the voltage from the ECM battery supply (-) to the ECM battery supply (+) pins in the ECM power harness connector. 	<p>Is the ECM battery supply voltage equal to the battery voltage?</p> <p>YES</p>	3F
<p>Measure the ECM voltage with the keyswitch in the ON position and also with the keyswitch in the Cranking position.</p> <p>Refer to the wiring diagram for connector pin identification.</p>	<p>Is the ECM battery supply voltage equal to the battery voltage?</p> <p>NO</p> <p>Repair:</p> <p>Repair or replace the ECM power harness.</p> <p>Check the battery connections and fuse terminals.</p>	Repair complete

STEP 3F: Verify the rail fuel pressure sensor accuracy.

<p>Condition:</p> <ul style="list-style-type: none"> • Connect INSITE™ electronic service tool. • Turn keyswitch ON. 		
Action	Specification/Repair	Next Step
<p>Monitor the rail fuel pressure sensor.</p> <p>Use INSITE™ electronic service tool, to monitor the rail fuel pressure sensor (measured) with the keyswitch ON and the engine OFF (not operating).</p>	<p>Is the rail fuel pressure sensor (measured) value less than 30 bar [435 psi]?</p> <p>YES</p>	3G
	<p>Is the rail fuel pressure sensor (measured) value less than 30 bar [435 psi]?</p> <p>NO</p> <p>Repair:</p> <p>Replace the rail fuel pressure sensor.</p> <p>Refer to Procedure 019-115 in Section 19 in the ISB, ISBe4, QSB4.5, QSB5.9, QSB6.7, ISC, QSC8.3, ISL, ISLe3 and QSL9 (Common Rail Fuel System) Series Engines, CM850 Electronic Control System Troubleshooting and Repair Manual, Bulletin 4021416.</p>	Repair complete

STEP 3G: Check for fuel rail pressure while cranking the engine.

<p>Condition:</p> <ul style="list-style-type: none"> • Connect INSITE™ electronic service tool. • Turn keyswitch ON. 		
Action	Specification/Repair	Next Step
<p>Check for fuel rail pressure.</p> <ul style="list-style-type: none"> • Attempt to start the engine by engaging the engine starter for at least 30 continuous seconds. • Use INSITE™ electronic service tool to monitor the Fuel Rail pressure (Measured) and Fuel Rail Pressure (Commanded). • Use INSITE™ electronic service tool to read the fault codes. <p>Attempting to start the engine for 30 continuous seconds allows the fault code logic time to perform. If Fault Code 2215 or Fault Code 559 becomes active, then fuel rail pressure is not being developed.</p> <p>If the engine starts during this attempt, it is possible that fuel prime to the high pressure pump has been lost. Look for loose fuel lines or filters that allow for loss of fuel prime.</p>	<p>Did Fault Code 2215 or Fault Code 559 become active during the failed start attempt?</p> <p>YES</p> <p>Repair:</p> <p>Follow troubleshooting Fault Codes 2215 or 559 Fuel Pump Delivery Pressure Low Choice.</p>	Repair complete
		<p>Did Fault Code 2215 or Fault Code 559 become active during the failed start attempt?</p> <p>NO</p>

STEP 3H: Check the fuel lift pump pressure.

Condition: <ul style="list-style-type: none"> • Turn keyswitch ON. 		
Action	Specification/Repair	Next Step
Install a pressure gauge at the inlet port of the fuel pump. <ul style="list-style-type: none"> • Measure the fuel lift pump output pressure. Refer to Procedure 005-045 in Section 5 in the ISB, ISBe, ISBe4, QSB4.5, QSB5.9, and QSB6.7 (Common Rail Fuel System) Series Engines Service Manual, Bulletin 4021271. At initial key ON, the lift pump will run for 60 seconds then stop if the engine is not started and not operating. The lift pump will operate continuously once the engine is operating.	Is the fuel lift pump pressure greater than the specifications? YES Repair: Replace the fuel pump. Refer to Procedure 005-016 in Section 5 in the ISB, ISBe, ISBe4, QSB4.5, QSB5.9, and QSB6.7 (Common Rail Fuel System) Series Engines Service Manual, Bulletin 4021271.	Repair complete
	Is the fuel lift pump pressure greater than the specifications? NO Repair: Replace the fuel lift pump. Refer to Procedure 005-045 in Section 5 in the ISB, ISBe, ISBe4, QSB4.5, QSB5.9, and QSB6.7 (Common Rail Fuel System) Series Engines Service Manual, Bulletin 4021271.	Repair complete

STEP 4: Fuel system troubleshooting procedures.

STEP 4A: Check for fault codes that pertain to the fuel system.

Condition: <ul style="list-style-type: none"> • Connect INSITE™ electronic service tool. • Turn keyswitch ON. 		
Action	Specification/Repair	Next Step
Check for fault codes. <ul style="list-style-type: none"> • Attempt to start the engine by engaging the starter for at least 30 continuous seconds. • Use INSITE™ electronic service tool to monitor Fuel Rail Pressure (Measured) and Fuel Rail Pressure (Commanded). • Use INSITE™ electronic service tool to read the fault codes. Attempting to start the engine for 30 continuous seconds allows the fault code logic time to perform. If Fault Code 2215 or Fault Code 559 becomes active, then fuel rail pressure is not being developed.	Did Fault Code 2215 or Fault Code 559 become active during the failed start attempt? YES Repair: Follow troubleshooting Fault Code 559 Fuel Pump Delivery Pressure Low choice.	Repair complete
	Did Fault Code 2215 or Fault Code 559 become active during the failed start attempt? NO	4B

STEP 4B: Check for air in the high pressure pump fuel supply.

Condition: None		
Action	Specification/Repair	Next Step
Check for air in the fuel. Refer to Procedure 006-003 in Section 6 in the ISB, ISBe, ISBe4, QSB4.5, QSB5.9, and QSB6.7 (Common Rail Fuel System) Series Engines Service Manual, Bulletin 4021271.	Is air present in the fuel supply? YES Repair: Locate and correct the cause of air ingestion in the fuel supply system. Sources of air ingestion include loose fuel filters, loose fuel line fittings, loose or cracked fuel tank stand-pipes, or severe restrictions in the fuel supply lines and filters.	Repair complete
	Is air present in the fuel supply? NO	4C

STEP 4C: Measure the fuel inlet restriction.

Condition: None		
Action	Specification/Repair	Next Step
Measure the fuel inlet restriction at the customer connection. Refer to Procedure 006-020 in Section 6 in the ISB, ISBe, ISBe4, QSB4.5, QSB5.9, and QSB6.7 (Common Rail Fuel System) Series Engines Service Manual, Bulletin 4021271. Maximum fuel inlet restriction at the customer connection <ul style="list-style-type: none"> • New Filter: 63.5 mm-Hg [2.5 in-Hg] • Dirty Filter: 101.6 mm-Hg [4.0 in-Hg] 	Is the fuel inlet restriction above specification? YES Repair: Find and correct the cause of high fuel inlet restriction. Look for plugged OEM fuel filters or screens, a restricted ECM cooler, pinched OEM fuel lines, or a restricted stand pipe in the OEM fuel tank.	Repair complete
	Is the fuel inlet restriction above specification? NO	4D

STEP 4D: Perform the single cylinder cutout test.

Condition: <ul style="list-style-type: none"> • Connect INSITE™ electronic service tool. • Turn keyswitch ON. • Start the engine and run at low idle. 		
Action	Specification/Repair	Next Step
Perform the single cylinder cutout test. <ul style="list-style-type: none"> • Operate the engine at load. • Use INSITE™ electronic service tool to perform the Cylinder Cutout test. Disable individual injectors. 	Can the miss or excessive smoke be attributed to a single cylinder? YES Repair: Look for a cause of the complaint, including valve lash and excessive crankcase pressure that can indicate power cylinder damage, or camshaft lobe wear. If no other damage is found, replace the fuel injector in the cylinder that was identified using the single cylinder cutout test. Refer to Procedure 006-026 in Section 6 in the ISB, ISBe, ISBe4, QSB4.5, QSB5.9, and QSB6.7 (Common Rail Fuel System) Series Engines Service Manual, Bulletin 4021271.	Repair complete
	Can the miss or excessive smoke be attributed to a single cylinder? NO	4E

STEP 4E: Perform the cylinder balance diagnostic test.

<p>Condition:</p> <ul style="list-style-type: none"> • Connect INSITE™ electronic service tool. • Turn keyswitch ON. 		
Action	Specification/Repair	Next Step
<p>Perform the cylinder balance diagnostic test.</p> <ul style="list-style-type: none"> • Use INSITE™ electronic service tool to perform the Cylinder Performance Test. Determine if a single cylinder is contributing to the engine symptom. 	<p>Does the Cylinder Performance Test identify any cylinder that is contributing to a power imbalance?</p> <p>YES</p> <p>Repair:</p> <p>Look for a cause of the power imbalance, including valve lash and excessive crankcase pressure that may indicate power cylinder damage or camshaft lobe wear. If no other damage is found, replace the fuel injector in the cylinder contributing to the power imbalance.</p> <p>Refer to Procedure 006-026 in Section 6 in the ISB, ISBe, ISBe4, QSB4.5, QSB5.9, and QSB6.7 (Common Rail Fuel System) Series Engines Service Manual, Bulletin 4021271.</p>	Repair complete
	<p>Does the Cylinder Performance Test identify any cylinder that is contributing to a power imbalance?</p> <p>NO</p>	4F

STEP 4F: Measure the fuel drain line restriction.

<p>Condition:</p> <p>None</p>		
Action	Specification/Repair	Next Step
<p>Measure the fuel drain line restriction.</p> <p>Refer to Procedure 006-012 in Section 6 in the ISB, ISBe, ISBe4, QSB4.5, QSB5.9, and QSB6.7 (Common Rail Fuel System) Series Engines Service Manual, Bulletin 4021271.</p>	<p>Is the fuel drain line restriction within specification?</p> <p>YES</p>	2A
	<p>Is the fuel drain line restriction within specification?</p> <p>NO</p> <p>Repair:</p> <p>Look for causes of high drain line restriction, such as kinked or blocked fuel lines.</p>	Repair complete

STEP 5: Air handling troubleshooting procedures.

STEP 5A: Check the intake manifold pressure sensor accuracy.

<p>Condition:</p> <ul style="list-style-type: none"> • Turn keyswitch ON. • Connect INSITE™ electronic service tool. • Engine OFF. 		
Action	Specification/Repair	Next Step
<p>Monitor the reading for intake manifold pressure with the engine off.</p> <ul style="list-style-type: none"> • Start INSITE™ electronic service tool data/logger and monitor the INSITE™ electronic service tool reading for intake manifold pressure with the engine off. Compare the pressure readings in INSITE™ to the local barometric pressure. Refer to Procedure 018-028 in Section V. 	<p>Is the intake manifold pressure reading less than 50.8 mm-Hg [2 in-Hg] of local barometric pressure?</p> <p>YES</p>	5B
	<p>Is the intake manifold pressure reading less than 50.8 mm-Hg [2 in-Hg] of local barometric pressure?</p> <p>NO</p> <p>Repair:</p> <p>Replace the intake manifold pressure sensor.</p> <p>Refer to Procedure 019-159 in Section 19 in Troubleshooting and Repair Manual, ISB, ISBe4, QSB4.5, QSB5.9, QSB6.7, ISC, QSC8.3, ISL, and QSL9 Engines, CM850 Electronic Control System, Bulletin 4021416.</p>	Repair complete

STEP 5B: Check the air intake system for leaks.

<p>Condition:</p> <p>None</p>		
Action	Specification/Repair	Next Step
<p>Check the air intake system for leaks.</p> <p>Refer to Procedure 010-024 in Section 10 in the ISB, ISBe, ISBe4, QSB4.5, QSB5.9, and QSB6.7 (Common Rail Fuel System) Series Engines Service Manual, Bulletin 4021271.</p>	<p>Were any air intake system leaks found?</p> <p>YES</p> <p>Repair:</p> <p>Repair or replace the damaged component.</p>	Repair complete
	<p>Were any air intake system leaks found?</p> <p>NO</p>	5C

STEP 5C: Check the air intake restriction.

<p>Condition:</p> <ul style="list-style-type: none"> • Install vacuum gauge Part Number ST1111-3 into the air intake system. • Turn keyswitch ON. • Engine operating at rated speed and full load. 		
Action	Specification/Repair	Next Step
<p>Measure the intake system restriction.</p> <p>Refer to Procedure 010-031 in Section 10 in the ISB, ISBe, ISBe4, QSB4.5, QSB5.9, and QSB6.7 (Common Rail Fuel System) Series Engines Service Manual, Bulletin 4021271.</p> <p>Maximum air intake restriction:</p> <p>Clean filter: 381 mm-H₂O [15 in-H₂O]</p> <p>Dirty filter: 635 mm-H₂O [25 in-H₂O]</p>	<p>Is the air intake restriction greater than the specification?</p> <p>YES</p> <p>Repair:</p> <p>Correct the cause of high intake air restriction. Check for plugged air filter or restricted air intake piping.</p>	<p>Repair complete</p>
	<p>Is the air intake restriction greater than the specification?</p> <p>NO</p>	<p>5D</p>

STEP 5D: Inspect the turbocharger blades for damage.

<p>Condition:</p> <ul style="list-style-type: none"> • Turn keyswitch OFF. • Remove the intake and exhaust pipes from the turbocharger. 		
Action	Specification/Repair	Next Step
<p>Inspect the turbocharger.</p> <ul style="list-style-type: none"> • Inspect the compressor blades for damage or wear. <p>Refer to Procedure 010-033 in Section 10 in the ISB, ISBe, ISBe4, QSB4.5, QSB5.9, and QSB6.7 (Common Rail Fuel System) Series Engines Service Manual, Bulletin 4021271.</p>	<p>Are the turbocharger blades damaged?</p> <p>YES</p> <p>Repair:</p> <p>Replace the turbocharger assembly.</p> <p>Refer to Procedure 010-033 in Section 10 in the ISB, ISBe, ISBe4, QSB4.5, QSB5.9, and QSB6.7 (Common Rail Fuel System) Series Engines Service Manual, Bulletin 4021271.</p>	<p>Repair complete</p>
	<p>Are the turbocharger blades damaged?</p> <p>NO</p>	<p>5E</p>

STEP 5E: Determine if the turbocharger is a wastegated turbocharger.

Condition: None		
Action	Specification/Repair	Next Step
Determine if the turbocharger is a wastegated turbocharger. N/A	Is the turbocharger a wastegated turbocharger? YES	5F
	Is the turbocharger a wastegated turbocharger? NO	5H

STEP 5F: Inspect the wastegate actuator hose.

Condition: <ul style="list-style-type: none"> • Turn keyswitch OFF. • Remove the turbocharger if the wastegate actuator is inaccessible. 		
Action	Specification/Repair	Next Step
Inspect the integral wastegate actuator hose for cracks or holes. Refer to Procedure 010-050 in Section 10 in the ISB, ISBe, ISBe4, QSB4.5, QSB5.9, and QSB6.7 (Common Rail Fuel System) Series Engines Service Manual, Bulletin 4021271.	Are holes or cracks found in the wastegate actuator hose? YES Repair: Replace the wastegate actuator hose. Refer to Procedure 010-050 in Section 10 in the ISB, ISBe, ISBe4, QSB4.5, QSB5.9, and QSB6.7 (Common Rail Fuel System) Series Engines Service Manual, Bulletin 4021271.	Repair complete
	Are holes or cracks found in the wastegate actuator hose? NO	5G

STEP 5G: Inspect the turbocharger wastegate capsule for air leaks

<p>Condition:</p> <ul style="list-style-type: none"> • Engine OFF. • Remove the wastegate actuator hose from the wastegate actuator. 		
Action	Specification/Repair	Next Step
<p>Perform a leak test on the wastegate actuator capsule.</p> <p>Use Wastegate Pressure Test Kit, Part Number 3823799, to apply a regulated air supply of 59 in-Hg to the wastegate actuator capsule. No air should be heard (a leaking noise) through a functional wastegate capsule.</p> <p>Refer to Procedure 010-050 in Section 10 in the ISB, ISBe, ISBe4, QSB4.5, QSB5.9, and QSB6.7 (Common Rail Fuel System) Series Engines Service Manual, Bulletin 4021271.</p>	<p>Did the wastegate actuator capsule leak air?</p> <p>YES</p> <p>Repair:</p> <p>Replace the wastegate actuator. Refer to Procedure 010-050 in Section 10 in the ISB, ISBe, ISBe4, QSB4.5, QSB5.9, and QSB6.7 (Common Rail Fuel System) Series Engines Service Manual, Bulletin 4021271.</p>	<p>Repair complete</p>
	<p>Did the wastegate actuator capsule leak air?</p> <p>NO</p>	<p>5G-1</p>

STEP 5G-1: Inspect the turbocharger wastegate for proper operation.

<p>Condition:</p> <ul style="list-style-type: none"> • Engine OFF. • Remove the wastegate actuator hose from the wastegate actuator. 		
Action	Specification/Repair	Next Step
<p>Check for wastegate actuator rod for movement.</p> <p>Use Wastegate Pressure Test Kit, Part Number 3823799, to apply a regulated air supply of [29 psi] to the wastegate actuator capsule. Check for wastegate actuator rod for movement.</p> <p>Refer to Procedure 010-050 in Section 10 in the ISB, ISBe, ISBe4, QSB4.5, QSB5.9, and QSB6.7 (Common Rail Fuel System) Series Engines Service Manual, Bulletin 4021271.</p>	<p>Did the wastegate actuator rod move?</p> <p>YES</p>	<p>5H</p>
	<p>Did the wastegate actuator rod move?</p> <p>NO</p>	<p>5G-2</p>

STEP 5G-2: Inspect the turbocharger wastegate for proper operation.

<p>Condition:</p> <ul style="list-style-type: none"> • Engine OFF. • Remove the e-clip from the wastegate pin and disconnect the actuator rod from the wastegate lever. 		
Action	Specification/Repair	Next Step
<p>Check for wastegate actuator rod movement with it disconnected from the turbocharger wastegate.</p> <p>Use Wastegate Pressure Test Kit, Part Number 3823799, to apply a regulated air supply of [29 psi] to the wastegate actuator capsule. Check for wastegate actuator rod for movement.</p> <p>Refer to Procedure 010-050 in Section 10 in the ISB, ISBe, ISBe4, QSB4.5, QSB5.9, and QSB6.7 (Common Rail Fuel System) Series Engines Service Manual, Bulletin 4021271.</p>	<p>Does the wastegate actuator rod move?</p> <p>YES</p> <p>Repair:</p> <p>Move the wastegate lever back and forth and check for smooth operation. If the wastegate lever does not move freely or binds, spray a penetrating oil on the wastegate lever joint and try to free the wastegate lever by working the lever back and forth. If the lever does not become free, then replace the turbocharger.</p> <p>Refer to Procedure 010-033 in Section 10 in the ISB, ISBe, ISBe4, QSB4.5, QSB5.9, and QSB6.7 (Common Rail Fuel System) Series Engines Service Manual, Bulletin 4021271.</p>	Repair complete
	<p>Does the wastegate actuator rod move?</p> <p>NO</p> <p>Repair:</p> <p>Replace the wastegate actuator. Refer to Procedure 010-050 in Section 10 in the ISB, ISBe, ISBe4, QSB4.5, QSB5.9, and QSB6.7 (Common Rail Fuel System) Series Engines Service Manual, Bulletin 4021271.</p>	Repair complete

STEP 5H: Measure turbocharger axial and radial clearance.

<p>Condition:</p> <ul style="list-style-type: none"> • Engine OFF. • Disconnect the exhaust and intake connections from the turbocharger. 		
Action	Specification/Repair	Next Step
<p>Follow the procedure for measuring the axial and radial clearances of the turbocharger.</p> <p>Refer to Procedure 010-033 in Section 10 in the ISB, ISBe, ISBe4, QSB4.5, QSB5.9, and QSB6.7 (Common Rail Fuel System) Series Engines Service Manual, Bulletin 4021271.</p>	<p>Are the axial and radial clearances within specification?</p> <p>YES</p>	5I
	<p>Are the axial and radial clearances within specification?</p> <p>NO</p> <p>Repair:</p> <p>Replace the turbocharger assembly.</p> <p>Refer to Procedure 010-033 in Section 10 in the ISB, ISBe, ISBe4, QSB4.5, QSB5.9, and QSB6.7 (Common Rail Fuel System) Series Engines Service Manual, Bulletin 4021271.</p>	Repair complete

STEP 5I: Inspect the aftercooler.

Condition: None		
Action	Specification/Repair	Next Step
Inspect the aftercooler. N/A	Is the aftercooler free of cracks or other damage? YES	2A
	Is the aftercooler free of cracks or other damage? NO Repair: Repair or replace the aftercooler assembly. Refer to Procedure 010-005 in Section 10 in the ISB, ISBe, ISBe4, QSB4.5, QSB5.9, and QSB6.7 (Common Rail Fuel System) Series Engines Service Manual, Bulletin 4021271.	Repair complete

STEP 6: Electronic feature troubleshooting procedures.

STEP 6A: Verify the throttle travel.

Condition: <ul style="list-style-type: none"> • Connect INSITE™ electronic service tool. • Turn keyswitch ON. 		
Action	Specification/Repair	Next Step
Verify the throttle travel. <ul style="list-style-type: none"> • Use INSITE™ electronic service tool to monitor throttle position while fully depressing and releasing the throttle lever. 	Does the throttle position read 0 when the throttle is released and 100 percent when the throttle is actuated? YES	2A
	Does the throttle position read 0 when the throttle is released and 100 percent when the throttle is actuated? NO Repair: Determine and correct the cause of the throttle lever restriction.	Repair complete

STEP 7: Base engine troubleshooting procedures

STEP 7A: Verify the overhead adjustments are correct.

Condition: • Turn keyswitch OFF.		
Action	Specification/Repair	Next Step
Measure the overhead settings. • Remove the rocker lever cover. Refer to Procedure 003-011 in Section 3 in the ISB, ISBe, ISBe4, QSB4.5, QSB5.9, and QSB6.7 (Common Rail Fuel System) Series Engines Service Manual, Bulletin 4021271. • Measure the overhead settings. Refer to Procedure 003-004 in Section 3 in the ISB, ISBe, ISBe4, QSB4.5, QSB5.9, and QSB6.7 (Common Rail Fuel System) Series Engines Service Manual, Bulletin 4021271.	Are the overhead settings within the reset limits? YES	7B
	Are the overhead settings within the reset limits? NO Repair: Adjust the overhead settings. Refer to Procedure 003-004 in Section 3 in the ISB, ISBe, ISBe4, QSB4.5, QSB5.9, and QSB6.7 (Common Rail Fuel System) Series Engines Service Manual, Bulletin 4021271.	Repair complete

STEP 7B: Check the exhaust restriction.

Condition: None		
Action	Specification/Repair	Next Step
Install a pressure gauge into the exhaust system just past the turbocharger outlet to check the exhaust system back pressure. Refer to Procedure 011-009 in Section 11 in the ISB, ISBe, ISBe4, QSB4.5, QSB5.9, and QSB6.7 (Common Rail Fuel System) Series Engines Service Manual, Bulletin 4021271.	Is the exhaust system back pressure less than 127 mm-Hg [5 in-Hg] or 1763 mm-H ₂ O [68 in-H ₂ O] or 17 kPa [2.5 psi]? YES	7C
	Is the exhaust system back pressure less than 127 mm-Hg [5 in-Hg] or 1763 mm-H ₂ O [68 in-H ₂ O] or 17 kPa [2.5 psi]? NO Repair: Fix or clear the source of high exhaust system restriction.	Repair complete

STEP 7C: Check the engine blowby.

Condition: None		
Action	Specification/Repair	Next Step
Measure the engine blowby. Refer to Procedure 014-005 in Section 14 in the ISB, ISBe, ISBe4, QSB4.5, QSB5.9, and QSB6.7 (Common Rail Fuel System) Series Engines Service Manual, Bulletin 4021271.	Are the engine blowby measurements within specification? YES	Return to step 2, or contact a local Cummins® Authorized Repair Location for further diagnostic and troubleshooting instructions.
	Are the engine blowby measurements within specification? NO	7C-1

STEP 7C-1: Verify the turbocharger contribution to the engine blowby.

Condition: <ul style="list-style-type: none"> • Turn keyswitch OFF. • Start the engine. 		
Action	Specification/Repair	Next Step
Verify the turbocharger contribution. <ul style="list-style-type: none"> • Connect the appropriate orifice to the end of the blowby draft tube. • Remove the turbocharger oil drain line from the block and drain into a bucket. • Load the engine to rated rpm. • Measure the engine blowby. Refer to Procedure 014-005 in Section 14 in the ISB, ISBe, ISBe4, QSB4.5, QSB5.9, and QSB6.7 (Common Rail Fuel System) Series Engines Service Manual, Bulletin 4021271. 	Has the total engine blowby dropped more than 30 percent of the total? YES Repair: Replace the turbocharger assembly. Refer to Procedure 010-033 in Section 10 in the ISB, ISBe, ISBe4, QSB4.5, QSB5.9, and QSB6.7 (Common Rail Fuel System) Series Engines Service Manual, Bulletin 4021271.	Repair complete
	Has the total engine blowby dropped more than 30 percent of the total? NO Repair: The engine may need to be rebuilt. Refer to Procedure 000-001 in Section 0 in the ISB, ISBe, ISBe4, QSB4.5, QSB5.9, and QSB6.7 (Common Rail Fuel System) Series Engines Service Manual, Bulletin 4021271 and the engine rebuild specifications.	Repair complete

STEP 8: Excessive vibration troubleshooting procedures.

STEP 8A: Check the gear ratio and propeller configuration.

Condition: • Turn keyswitch OFF.		
Action	Specification/Repair	Next Step
Check for an incorrect matching of the gear ratio and propeller to the engine power. N/A	Are the gear ratio and the propeller incorrectly matched to the engine power? YES Repair: Contact a Cummins® Distributor or Marine District Field Service Manager.	Repair complete
	Are the gear ratio and the propeller incorrectly matched to the engine power? NO	8B

STEP 8B: Check for the correct engine mounting isolators and for proper installation requirements.

Condition: None		
Action	Specification/Repair	Next Step
Check for the correct engine mount isolators and for propeller installation requirements. N/A	Are the engine mount isolators correct and installed correctly? YES	8C
	Are the engine mount isolators correct and installed correctly? NO Repair: Check for proper isolator installation requirements. Replace and repair vibration isolators as needed. Refer to Procedure 016-026 in Section 16 in the ISB, ISBe, ISBe4, QSB4.5, QSB5.9, and QSB6.7 (Common Rail Fuel System) Series Engines Service Manual, Bulletin 4021271 and Engine Mounting/Drive Systems section in the Marine Recreational Installation Directions, Bulletin 3884649. If the isolators are not manufactured by Cummins Inc., refer to the OEM service manual.	Repair complete

STEP 8C: Check for damaged engine mounts and isolators.

Condition: None		
Action	Specification/Repair	Next Step
Inspect the engine mount and isolators for failure. N/A	Are the engine mounts and isolators in good condition? YES	8D
	Are the engine mounts and isolators in good condition? NO Repair: Remove and replace the engine mount isolators. Refer to Procedure 016-026 in Section 16 in the ISB, ISBe, ISBe4, QSB4.5, QSB5.9, and QSB6.7 (Common Rail Fuel System) Series Engines Service Manual, Bulletin 4021271 and Engine Mounting/Drive Systems section in the Marine Recreational Installation Directions, Bulletin 3884649. If the isolators are not manufactured by Cummins Inc., refer to the OEM service manual.	Repair complete

STEP 8D: Check the exhaust system.

Condition: None		
Action	Specification/Repair	Next Step
Check for exhaust system deficiencies. N/A	Is the exhaust system deficient? YES Repair: Repair or replace as needed. See the Exhaust System section in the Marine Recreational Installation Directions, Bulletin 3884649 and the OEM service manual and instructions.	Repair complete
	Is the exhaust system deficient? NO	8E

STEP 8E: Check the engine driven accessories.

Condition: <ul style="list-style-type: none"> • Turn keyswitch ON. • Turn keyswitch OFF. 		
Action	Specification/Repair	Next Step
Check for engine driven accessories malfunctions. Isolate or disconnect the accessories and check for vibration. Do not operate the engine if the sea water pump is disconnected.	Is an engine driven accessory malfunctioning? YES Repair: Determine the cause of the malfunctioning accessories and correct the problem. See the Engine Driven Accessories section in the Marine Recreational Installation Directions, Bulletin 3884649. If the accessory is not installed by Cummins Inc., refer to the OEM service manual.	Repair complete
	Is an engine driven accessory malfunctioning? NO	8F

STEP 8F: Check the shaft coupling to gear coupling alignment.

Condition: <ul style="list-style-type: none"> • Turn keyswitch OFF. 		
Action	Specification/Repair	Next Step
Check the shaft coupling to gear coupling alignment. N/A	Is the shaft coupling to gear coupling misaligned? YES Repair: Repair or replace as needed. Refer to Procedure 016-025 in Section 16 in the ISB, ISBe, ISBe4, QSB4.5, QSB5.9, and QSB6.7 (Common Rail Fuel System) Series Engines Service Manual, Bulletin 4021271 and Engine Mounting/Drive Systems section in the Marine Recreational Installation Directions, Bulletin 3884649, and the gear manufacturer's recommendations.	Repair complete
	Is the shaft coupling to gear coupling misaligned? NO	8G

STEP 8G: Check the propeller shaft for proper installation.

Condition: None		
Action	Specification/Repair	Next Step
Check the propeller shaft for proper installation. N/A	Is the propeller shaft installed correctly? YES	8H
	Is the propeller shaft installed correctly? NO Repair: Repair or replace as needed. Refer to Procedure 016-025 in Section 16 in the ISB, ISBe, ISBe4, QSB4.5, QSB5.9, and QSB6.7 (Common Rail Fuel System) Series Engines Service Manual, Bulletin 4021271 and Engine Mounting/Drive Systems section in the Marine Recreational Installation Directions, Bulletin 3884649, and the gear manufacturer's recommendations.	Repair complete

STEP 8H: Check the propeller shaft for straightness.

Condition: None		
Action	Specification/Repair	Next Step
Check the propeller shaft for straightness. N/A	Is the propeller shaft straightness within the OEM specification? YES	8I
	Is the propeller shaft straightness within the OEM specification? NO Repair: Repair or replace the propeller shaft as needed. Contact a Cummins® Authorized Repair Location.	Repair complete

STEP 8I: Isolate the engine.

Condition: <ul style="list-style-type: none"> • Turn keyswitch ON. • Turn keyswitch OFF. 		
Action	Specification/Repair	Next Step
Operate the engine without the drive shaft attached at the coupler. N/A	Does the engine vibration persist? YES Repair: Check the engine vibration damper for damage. Repair or replace as needed. Refer to Procedure 001-052 in Section 1 in the ISB, ISBe, ISBe4, QSB4.5, QSB5.9, and QSB6.7 (Common Rail Fuel System) Series Engines Service Manual, Bulletin 4021271.	Repair complete
	Does the engine vibration persist? NO	8J

STEP 8J: Check for strut/cutlass bearing misalignment.

Condition: <ul style="list-style-type: none"> • Turn keyswitch OFF. 		
Action	Specification/Repair	Next Step
Check for strut/cutlass bearing misalignment or strut mounting is not secure. N/A	Is the strut/cutlass bearing misaligned or strut mounting not secure? YES Repair: Check the strut for mounting stiffness. Repair or replace as needed. Contact a Authorized Cummins® Repair Location.	Repair complete
	Is the strut/cutlass bearing misaligned or strut mounting not secure? NO	8K

STEP 8K: Check the propeller.

Condition: None		
Action	Specification/Repair	Next Step
Check for propeller out-of-balance or propeller not fitted properly to shaft. N/A	Is the propeller out of balance or not fitted properly to the shaft? YES Repair: Check the propeller for accuracy. Repair or replace as needed. Contact a Cummins® Authorized Repair Location	Repair complete
	Is the propeller out of balance or not fitted properly to the shaft? NO	8L

STEP 8L: Check the V-angle on the V-strut.

Condition: None		
Action	Specification/Repair	Next Step
Check to see if the V-angle on the V-strut does not match the angle of the blade on the prop. N/A	Does the V-angle on the V-strut match the angle of the blade on the prop? YES	8M
	Does the V-angle on the V-strut match the angle of the blade on the prop? NO Repair: Repair or replace as needed. Contact a Cummins® Authorized Repair Location	Repair complete

STEP 8M: Check the propeller tunnels.

Condition: None		
Action	Specification/Repair	Next Step
Check if the propeller tunnels are properly matched with the propellers. N/A	Does the entry and exit of the propeller tunnel match with the propeller blades? YES	8N
	Does the entry and exit of the propeller tunnel match with the propeller blades? NO Repair: Repair or replace as needed. Contact a Cummins® Authorized Repair Location	Repair complete

STEP 8N: Check the engine to transmission torsional coupling.

Condition: None		
Action	Specification/Repair	Next Step
Check for incorrect or worn torsional coupling. N/A	Is the torsional coupling incorrect or worn? YES Repair: Replace the coupling. Refer to the OEM service manual.	Repair complete
	Is the torsional coupling incorrect or worn? NO	8O

STEP 8O: Check the rudder.

Condition: None		
Action	Specification/Repair	Next Step
Check the rudder for excessive play in the rudder post. N/A	Does the rudder have excessive play in the rudder post? YES Repair: Repair or replace as needed. Contact a Cummins® Authorized Repair Location	Repair complete
	Does the rudder have excessive play in the rudder post? NO	8P

STEP 8P: Check the engine flywheel housing to cylinder block alignment.

<p>Condition: None</p>		
Action	Specification/Repair	Next Step
<p>Check the engine flywheel housing to cylinder block alignment. N/A</p>	<p>Is the flywheel housing alignment incorrect? YES Repair: Realign the flywheel housing to cylinder block. Refer to Procedure 016-006 in Section 16 in the ISB, ISBe, ISBe4, QSB4.5, QSB5.9, and QSB6.7 (Common Rail Fuel System) Series Engines Service Manual, Bulletin 4021271.</p>	<p>Repair complete</p>
	<p>Is the flywheel housing alignment incorrect? NO Repair: The engine might have internal damage that has not been detected. Analyze the oil and inspect the filters to locate an area of probable damage. Refer to Procedure 007-083 in Section 7 in the ISB, ISBe, ISBe4, QSB4.5, QSB5.9, and QSB6.7 (Common Rail Fuel System) Series Engines Service Manual, Bulletin 4021271. The engine might need to be rebuilt. Refer to Procedure 000-001 in Section 0 in the ISB, ISBe, ISBe4, QSB4.5, QSB5.9, and QSB6.7 (Common Rail Fuel System) Series Engines Service Manual, Bulletin 4021271 and the engine rebuild specifications. If the engine is not damaged, the problem might be the vessel design. Contact a Cummins Authorized Repair Location</p>	<p>Repair complete</p>

Engine Performance Troubleshooting Tree - ISB Engines Equipped with EGR (CM850 Electronic Control System)

This troubleshooting procedure should be followed for the following symptoms:

- Engine Acceleration or Response Poor
- Engine Difficult to Start or Will Not Start (Exhaust Smoke)
- Engine Difficult to Start or Will Not Start (No Exhaust Smoke)
- Engine Power Output Low
- Engine Runs Rough at Idle
- Engine Runs Rough or Misfires
- Engine Speed Surges at Low or High Idle
- Engine Speed Surges Under Load or in Operating Range
- Smoke, Black - Excessive
- Smoke, White - Excessive
- Engine Shuts Off or Dies Unexpectedly or Dies during Deceleration
- Engine Decelerates Slowly
- Engine Starts but Will Not Keep Running
- Engine Will Not Reach Rated Speed (RPM)
- Intake Manifold Pressure (Boost) is Below Normal
- Engine Vibration Excessive

How to Use This Troubleshooting Procedure:

This symptom tree can be used to troubleshoot all performance based symptoms listed above. Start by performing Step 1 troubleshooting. Step 2 will ask a series of questions and will provide a list of troubleshooting steps to perform, depending on the symptom. Perform the list of troubleshooting in the sequence shown in the Specifications/Repair section of the tree.

Many steps will reference using the electronic service to INSITE™ electronic service tool to check for fault codes, perform tests, monitor data, and check features and parameters. It is recommended that INSITE™ electronic service tool remain connected while using this troubleshooting tree to periodically check for fault codes. If any fault codes become active during use of the troubleshooting tree, discontinue using this troubleshooting tree and troubleshoot the active fault code.

This symptom tree often references other procedures and symptom trees. The procedures and symptom trees referenced may not be located in the same service literature as this symptom tree. Use the following procedure for a listing of the service literature available for the engine being serviced. Refer to Procedure 205-001 in Section L.

Shop Talk:

Driveability is a term that in general describes vehicle performance on the road. Driveability problems for an engine can be caused by several different factors. Some of the factors are engine-related and some are **not**. Before troubleshooting, it is important to determine the exact complaint and whether the engine has a real driveability problem or if it simply does not meet driver expectations.

Low power is a term that is used in the field to describe many different performance problems. Low power is defined as the inability of the engine to produce the power necessary to move the vehicle at a speed that can be reasonably expected under the given conditions of load, grade, wind, and so on. With industrial equipment, low power might reference the inability of the equipment to pick up or maintain load.

Poor acceleration or response is described as the inability of the vehicle to accelerate satisfactorily from a stop or from the bottom of a grade. It can also be the lag in acceleration during an attempt to pass or overtake another vehicle at conditions less than rated speed and load. Poor acceleration or response is difficult to troubleshoot since it can be caused by several factors.

TROUBLESHOOTING SUMMARY

STEPS	SPECIFICATIONS	SRT CODE
STEP 1: Perform basic troubleshooting procedures.		
STEP 1A: Check for active fault codes or high counts of inactive fault codes.	Active fault codes or high counts of inactive fault codes?	
STEP 1B: Perform basic troubleshooting checks.	All steps have been verified to be correct?	
STEP 2: Determination of engine symptom.		
STEP 2A: Engine Difficult to Start or Will Not Start (With or Without Exhaust Smoke), Engine Shuts Off or Dies Unexpectedly or Dies during Deceleration, or Engine Starts but Will Not Keep Running.	Is the engine symptom Engine Difficult to Start or Will Not Start (With or Without Exhaust Smoke), Engine Shuts Off or Dies Unexpectedly or Dies during Deceleration, or Engine Starts but Will Not Keep Running?	
STEP 2B: Engine Runs Rough at Idle, Engine Runs Rough or Misfires, Engine Speed Surges at Low or High Idle, Engine Speed Surges under Load or in Operating Range.	Is the engine symptom Engine Runs Rough at Idle, Engine Runs Rough or Misfires, Engine Speed Surges at Low or High Idle, Engine Speed Surges under Load or in Operating Range?	
STEP 2C: Excessive white smoke.	Is the engine symptom Smoke, Black Excessive?	
STEP 2D: Excessive white smoke.	Is the engine symptom Smoke, White Excessive?	
STEP 2D-1: Excessive white smoke.	Is the engine using coolant?	
STEP 2D-2: Excessive white smoke.	Is the white smoke excessive complaint only occurring when the engine is cold and during cold ambient conditions?	
STEP 2E: Engine Acceleration or Response Poor, Engine Power Output Low, Engine Decelerates Slowly, or Engine Will Not Reach Rated Speed (RPM).	Is the engine symptom Engine Acceleration or Response Poor, Engine Power Output Low, Engine Decelerates Slowly, Intake Manifold Pressure (Boost) is Below Normal or Engine Will Not Reach Rated Speed (RPM)?	
STEP 2F: Intake Manifold Pressure (Boost) is Below Normal	Is the engine symptom Engine Vibration Excessive?	
STEP 3: Engine will Not Start or Stalls Troubleshooting Procedures.		
STEP 3A: Verify the operation of cold weather starting aids.	Are the necessary cold weather starting aids being used and are operational as required?	
STEP 3B: Check electronic features and programmable parameters.	Are electronic features and programmable parameters the cause for the engine shutting down or the no-start complaint?	
STEP 3C: Monitor the engine speed during cranking.	Is the engine speed greater than 150 rpm during cranking?	

STEP 3D:	Monitor the ECM Keyswitch Input.	Does the User Fueling State indicate Cranking or is the keyswitch voltage equal to battery voltage?
STEP 3E:	Monitor the ECM Battery Supply.	Is the ECM battery supply voltage greater than +11-VDC for 12 volt systems or +22-VDC for 24 volt systems?
STEP 3F:	Check the Load Carrying Capabilities of the ECM Power and Ground Circuits.	Do the headlights illuminate brightly?
STEP 3G:	Check orientation of connector.	Is the sensor correctly installed?
STEP 3H:	Verify rail fuel pressure sensor accuracy.	Is the Fuel Rail Pressure (measured) less than 30 bar [435]?
STEP 3I:	Monitor fuel rail pressure while cranking the engine.	Did the Fuel Rail Pressure (measured) equal the Fuel Rail Pressure (commanded)?
STEP 4:	Fuel system troubleshooting procedures.	
STEP 4A:	Check for air in the fuel supply line.	Is air present in the fuel supply?
STEP 4B:	Measure fuel flow/pressure at the inlet of the on engine fuel filter.	Was the pressure/flow measured within the specification?
STEP 4C:	Measure the fuel inlet restriction.	Is the fuel inlet restriction greater than the specification?
STEP 4D:	Check if the engine is equipped with a lift pump voltage regulator	Is the engine equipped with a lift pump voltage regulator?
STEP 4E:	Measure fuel pressure at the outlet of the on engine fuel filter.	Is the pressure drop across the filter greater than the specification?
STEP 4F:	Perform INSITE™ electronic service tool single cylinder cut-out test.	Can the miss or excessive smoke be attributed to a single cylinder?
STEP 4G:	Perform a manual single cylinder cut-out test.	Did the engine start after blocking off a cylinder(s) or can the miss or excessive smoke be attributed to a cylinder(s)?
STEP 4H:	Measure the injector return fuel drain flow from the cylinder head.	Is injector fuel drain flow from the cylinder head greater than specification?
STEP 4I:	Determine which cylinder(s) is causing excessive injector fuel drain flow from the cylinder head.	Did blocking off a cylinder(s) decrease the flow rate below the maximum specified flow rate?
STEP 4J:	Monitor Commanded Fuel Rail Pressure and Measured Fuel Rail Pressure.	Does the Measured Fuel Rail Pressure vary more than ± 35 bar [± 500 psi] from the Commanded Fuel Rail Pressure?
STEP 4K:	Check the fuel pressure relief valve for excessive leakage.	Is the fuel pressure relief valve within specification?

STEP 4L:	Measure the high-pressure fuel supply pump fuel drain flow.	Is the high pressure fuel supply pump fuel return flow greater than specification?
STEP 4M:	Measure fuel drain line restriction.	Is the drain line restriction less than specification?
STEP 5:	Air handling troubleshooting procedures	
STEP 5A:	Check intake manifold pressure sensor accuracy.	Intake manifold pressure reading is less than 102 mm-Hg [4 in-Hg]?
STEP 5B:	Check the Air intake System for Leaks.	Were any air intake system leaks found?
STEP 5C:	Check air intake restriction.	Is the air intake restriction greater than the specification?
STEP 5D:	Inspect the turbocharger blades for damage.	Damage found on the turbocharger blades?
STEP 5E:	Determine if the turbocharger is a variable geometry turbocharger.	Is the turbocharger a variable geometry turbocharger?
STEP 5F:	Perform INSITE™ electronic service tool turbocharger actuator test.	Does the turbocharger pass the turbocharger actuator test?
STEP 5G:	Inspect the wastegate actuator hose.	Holes or cracks found in the wastegate actuator hose?
STEP 5H:	Inspect the turbocharger wastegate capsule for air leaks.	Did the wastegate actuator capsule leak air?
STEP 5H-1:	Inspect the turbocharger wastegate actuator for proper operation.	Does the wastegate actuator rod move?
STEP 5H-2:	Inspect the turbocharger wastegate for proper operation.	Does the wastegate actuator rod move?
STEP 5I:	Measure turbocharger axial and radial clearance.	Are the axial and radial clearances within specification?
STEP 5J:	Inspect the charge-air cooler.	Does the charge-air cooler pass the visual inspection as well as the pressure test and temperature differential test?
STEP 6:	EGR System checks.	
STEP 6A:	Check for air leaks in the EGR system.	Air leaks found in the EGR connection tubing?
STEP 6B:	Check the EGR temperature sensor accuracy.	Are all temperature readings within 5.6°C or 10°F of each other?
STEP 6C:	Check differential pressure sensor for proper operation.	Is the EGR differential pressure greater than 5 mm-Hg [0.2 in-Hg] when the EGR valve is open greater than 50 percent?
STEP 6D:	Check exhaust gas pressure sensor accuracy.	There is less than a 102 mm-Hg [4 in-Hg] difference between the exhaust pressure sensor reading and the barometric air pressure sensor reading?

STEP 6E:	Perform the INSITE™ electronic service tool EGR valve actuator test.	Does the EGR Valve pass the INSITE™ EGR Valve Actuator Test?
STEP 6F:	Isolate EGR System.	Was the Performance or Excessive Smoke (Black) complaint corrected by disconnecting the EGR valve differential pressure sensor?
STEP 6F-1:	Check the EGR System for Blockage.	Was blockage or excessive carbon build up found in the EGR valve differential pressure sensor and/or intake connection passages?
STEP 6F-2:	Check the EGR system for correct or damaged components.	Was the air intake connection assembled properly with no damage to any components?
STEP 7:	Verify electronic features are operating correctly.	
STEP 7A:	Verify accelerator (throttle) pedal travel.	Does the throttle position read 0 percent when the accelerator (throttle) is released and 100 percent when the accelerator (throttle) is fully depressed?
STEP 7B:	Monitor the vehicle speed.	Does the vehicle speed read zero when the vehicle is not moving?
STEP 7C:	Verify the electronic feature settings are correct.	Are the electronic features set correctly?
STEP 7D:	Check the temperature sensor accuracy.	Are all temperature readings within 5.6°C or 10°F of each other?
STEP 7E:	Check ambient air pressure sensor accuracy	INSITE™ electronic service tool reading is within 102 mm-Hg [4 in-Hg] of local barometric pressure?
STEP 8:	Perform base engine mechanical checks.	
STEP 8A:	Verify the overhead adjustments are correct.	Are the overhead settings within the reset limits?
STEP 8B:	Check the exhaust restriction.	Is the exhaust back pressure greater than the specification?
STEP 8C:	Verify the engine crankcase pressure (blowby) is within specification.	Is the engine crankcase pressure (blowby) less than specification?
STEP 8D:	Check for internal engine damage.	Did cutting the oil filter open reveal evidence of internal engine damage?
STEP 9:	Excessive vibration checks.	
STEP 9A:	Check engine idle speed.	Is the engine idle speed within specification?
STEP 9B:	Check if the feature Fast Idle Warm Up is available and enabled.	Is the feature Fast Idle Warm Up available and enabled?
STEP 9B-1:	Monitor if the Fast Idle Warm Up Status.	Is the feature Fast Idle Warm Up becoming active?

STEP 9C:	Check front engine driven accessory(s).	Did isolating the front engine driven accessory(s) correct the vibration?
STEP 9D:	Check the Vibration Damper/ Crankshaft speed indicator ring.	Is the vibration damper/ crankshaft speed indicator ring damaged?
STEP 9E:	Check the Engine Support Brackets, Mounts and/or Isolators.	Are the engine support brackets, mounts and/or isolators or damaged?
STEP 9F:	Check engine gear driven accessory(s).	Does the engine have an engine gear driven/air compressor driven hydraulic pump?
STEP 9F-1:	Isolate engine gear driven accessory(s)	Did isolating/removing engine gear driven/air compressor driven hydraulic pump correct the vibration?
STEP 9F-2:	Check if the engine is equipped with an air compressor.	Is the engine equipped with an engine gear driven air compressor?
STEP 9F-3:	Unload the Air Compressor and Operate.	Did unloading the air compressor significantly reduce or eliminate the vibration?
STEP 9F-4:	Check Air Compressor Timing.	Was the air compressor correctly timed to the engine?
STEP 9G:	Check/Isolate engine driven components.	Did isolating/removing any engine driven component correct the vibration?
STEP 9H:	Check the Flywheel Housing Alignment.	Is the flywheel housing bore and face runout within specification?

TROUBLESHOOTING STEP

STEP 1: Perform basic troubleshooting procedures.

STEP 1A: Check for active fault codes or high counts of inactive fault codes.

Condition: <ul style="list-style-type: none"> • Turn keyswitch ON. • Connect INSITE™ electronic service tool. 		
Action	Specification/Repair	Next Step
Check for an active fault code. • Use INSITE™ electronic service tool to read the fault codes. Reference the corresponding Electronics Troubleshooting and Repair Manual for the engine being serviced. For engines equipped with a CM850 Electronic Control Module, reference Bulletin 4021416.	Active fault codes or high counts of inactive fault codes? YES Repair: Follow the electronic fault code trees for the appropriate troubleshooting procedures.	Repair complete.
	Active fault codes or high counts of inactive fault codes? NO	1B

STEP 1B: Perform basic troubleshooting checks.

Condition: N/A		
Action	Specification/Repair	Next Step
The following items must be checked or verified before continuing: <ul style="list-style-type: none"> • Verify the fuel level in the tanks. • Verify the vehicle is in good working order • Check if any recent maintenance or service work has been performed • Verify there have not been any changes to CPL components on the engine. • Verify fuel grade is correct for the application. • Verify the engine is operating within the recommended altitude. • Verify engine oil is in good condition and at the correct level. • Verify engine parasitics have not changed. • Verify engine duty cycle has not changed. • Verify the air filter is not excessively plugged, by checking the filter minder. • Listen for air and exhaust leaks. • Verify there are no visible external fuel leaks. • Verify there are no visible coolant leaks. • Verify there are no visible signs (soot streaks) of an external EGR leak. • Verify the crankshaft position and the camshaft position sensors are correctly connected to the engine harness. 	All steps have been verified to be correct? YES	2A
	All steps have been verified to be correct? NO Repair: Correct the condition and verify complaint is no longer present after repair.	Repair complete.

STEP 2: Determination of engine symptom.

STEP 2A: Engine Difficult to Start or Will Not Start (With or Without Exhaust Smoke), Engine Shuts Off or Dies Unexpectedly or Dies during Deceleration, or Engine Starts but Will Not Keep Running.

<p>Condition: N/A</p>		
Action	Specification/Repair	Next Step
<p>Interview the driver and verify the complaint. N/A</p>	<p>Is the engine symptom Engine Difficult to Start or Will Not Start (With or Without Exhaust Smoke), Engine Shuts Off or Dies Unexpectedly or Dies during Deceleration, or Engine Starts but Will Not Keep Running? YES Repair: Perform the troubleshooting steps in the recommended order listed below: Step 3 - Engine will Not Start or Stalls Troubleshooting Procedures Step 4 - Fuel System Checks Step 5 - Air Handling Checks Step 7 - Electronics Checks.</p>	<p>Perform the troubleshooting steps suggested in the repair procedure.</p>
	<p>Is the engine symptom Engine Difficult to Start or Will Not Start (With or Without Exhaust Smoke), Engine Shuts Off or Dies Unexpectedly or Dies during Deceleration, or Engine Starts but Will Not Keep Running? NO</p>	<p>2B</p>

STEP 2B: Engine Runs Rough at Idle, Engine Runs Rough or Misfires, Engine Speed Surges at Low or High Idle, Engine Speed Surges under Load or in Operating Range.

Condition: N/A		
Action	Specification/Repair	Next Step
Interview the driver and verify the complaint. N/A	Is the engine symptom Engine Runs Rough at Idle, Engine Runs Rough or Misfires, Engine Speed Surges at Low or High Idle, Engine Speed Surges under Load or in Operating Range? YES Repair: Perform the troubleshooting steps in the recommended order listed below: Step 4 - Fuel System Checks Step 7 - Electronic Checks Step 5 - Air Handling Checks	Perform the troubleshooting steps suggested in the repair procedure.
	Is the engine symptom Engine Runs Rough at Idle, Engine Runs Rough or Misfires, Engine Speed Surges at Low or High Idle, Engine Speed Surges under Load or in Operating Range? NO	2C

STEP 2C: Smoke, Black - Excessive

Condition: N/A		
Action	Specification/Repair	Next Step
Interview the driver and verify the complaint. N/A	Is the engine symptom Smoke, Black Excessive? YES Repair: Perform the troubleshooting steps in the recommended order listed below: Step 6 - EGR System Checks Step 5 - Air Handling Checks Step 4 - Fuel System Checks Step 7 - Electronics Checks Step 8 - Base Engine Checks	Perform the troubleshooting steps suggested in the repair procedure.
	Is the engine symptom Smoke, Black Excessive? NO	2D

STEP 2D: Smoke, White - Excessive.

Condition: N/A		
Action	Specification/Repair	Next Step
Interview the driver and verify the complaint. N/A	Is the engine symptom Smoke, White Excessive? YES	Step 2D-1
	Is the engine symptom Smoke, White Excessive? NO	Step 2E

STEP 2D-1: Smoke, White Excessive.

Condition: N/A		
Action	Specification/Repair	Next Step
Interview the driver and verify the complaint. Verify if, along with the white smoke complaint, coolant is being used. Check the coolant level.	Is the engine using coolant? YES	Refer to the Coolant Loss - Internal Troubleshooting Symptom (TS) Tree.
	Is the engine using coolant? NO	Step 2D-2

STEP 2D-2: Smoke, White Excessive

<p>Condition: N/A</p>		
Action	Specification/Repair	Next Step
<p>Interview the driver and verify the complaint. Check if the white smoke excessive complaint is only occurring when the engine is cold and during cold ambient conditions? Some white smoke after a cold start in cold ambient conditions is not uncommon. If white smoke persists once the engine has reached the minimum operating coolant temperature, troubleshoot the white smoke complaint. Minimum Operating Coolant Temperature: 60°C [140°F]</p>	<p>Is the white smoke excessive complaint only occurring when the engine is cold and during cold ambient conditions? YES Repair: Perform the Checks in Step 3A only Step 4 - Fuel System Checks Step 7 - Electronics Checks</p>	<p>Perform the troubleshooting steps suggested in the repair procedure.</p>
	<p>Is the white smoke excessive complaint only occurring when the engine is cold and during cold ambient conditions? NO Repair: Perform the troubleshooting steps in the recommended order listed below: Step 4 - Fuel System Checks Step 7 - Electronics Checks</p>	<p>Perform the troubleshooting steps suggested in the repair procedure.</p>

STEP 2E: Engine Acceleration or Response Poor, Engine Power Output Low, Engine Decelerates Slowly, Intake Manifold Pressure (Boost) is Below Normal or Engine Will Not Reach Rated Speed (RPM)

Condition: N/A		
Action	Specification/Repair	Next Step
Interview the driver and verify the complaint. N/A	Is the engine symptom Engine Acceleration or Response Poor, Engine Power Output Low, Engine Decelerates Slowly, Intake Manifold Pressure (Boost) is Below Normal or Engine Will Not Reach Rated Speed (RPM)? YES Repair: Perform the troubleshooting steps in the recommended order listed below: Step 5 - Air Handling Checks Step 4 - Fuel Systems Checks Step 7 - Electronics Checks Step 8 - Base Engine Checks	Perform the troubleshooting steps suggested in the repair procedure.
	Is the engine symptom Engine Acceleration or Response Poor, Engine Power Output Low, Engine Decelerates Slowly, Intake Manifold Pressure (Boost) is Below Normal or Engine Will Not Reach Rated Speed (RPM)? NO	Step 2F

STEP 2F: Engine Vibration Excessive

Condition: N/A		
Action	Specification/Repair	Next Step
Interview the driver and verify the complaint. N/A	Is the engine symptom Engine Vibration Excessive? YES Repair: Perform the troubleshooting steps in the recommended order listed below: Perform Step 4G and 4H of the Fuel System Checks Only Step 9 - Excessive Vibration Checks Step 8 - Base Engine Checks	Perform the troubleshooting steps suggested in the repair procedure.
	Is the engine symptom Engine Vibration Excessive? NO	For engine related symptoms, refer to the correct troubleshooting symptom (TS) tree.

STEP 3: Engine will Not Start or Stalls Troubleshooting Procedures.

STEP 3A: Verify the operation of cold weather aids.

<p>Condition:</p> <ul style="list-style-type: none"> • Engine and Ambient Conditions Cold. • Turn keyswitch ON. 		
Action	Specification/Repair	Next Step
<p>Make sure the necessary cold weather aids are being used and are operational as required.</p> <p>Minimum Ambient Air Temperature for Unaided Cold Start is 12.2°C [10°F]</p> <p>The INSITE™ electronic service tool Intake Air Heater Override test can be used to diagnose intake air heater problems. For engines equipped with air intake heaters, the air intake heaters should begin to function at 19°C [66°F].</p>	<p>Are the necessary cold weather starting aids are being used and are operational as required?</p> <p>YES</p>	3B
	<p>Are the necessary cold weather starting aids are being used and are operational as required?</p> <p>NO</p> <p>Repair:</p> <p>Install or repair cold weather starting aids.</p> <ul style="list-style-type: none"> • For the engine coolant heater, use the following procedure in the ISBe, ISB, QSB (Common Rail Fuel System) Service Manual, Bulletin 4021271. Refer to Procedure 008-011 in Section 8. • For the intake air heater(s), use the following procedure in the ISBe, ISB, QSB (Common Rail Fuel System) Service Manual, Bulletin 4021271. Refer to Procedure 010-029 in Section 10. • For the engine oil heaters, use the following procedure in the ISBe, ISB, QSB (Common Rail Fuel System) Service Manual, Bulletin 4021271. Refer to Procedure 007-001 in Section 7. • For any OEM installed cold starting aids (radiator shutters, etc.), refer to the OEM service manual. 	Repair complete

STEP 3B: Check electronic features and programmable parameters.

<p>Condition:</p> <ul style="list-style-type: none"> • Turn keyswitch ON. • Connect INSITE™ electronic service tool. 		
Action	Specification/Repair	Next Step
<p>Check if the electronic features and programmable parameters are the cause for the engine shutting down or the no-start complaint.</p> <p>The electronic features and programmable parameters include: Idle Shutdown, Engine Protection Shutdown, and Vehicle Anti-theft Protection.</p>	<p>Are electronic features and programmable parameters the cause for the engine shutting down or the no-start complaint?</p> <p>YES</p> <p>Repair:</p> <p>Program the electronic features per the customer or OEM requirements.</p>	<p>Repair Complete.</p>
	<p>Are electronic features and programmable parameters the cause for the engine shutting down or the no-start complaint?</p> <p>NO</p>	<p>Step 3C</p>

STEP 3C: Monitor the engine speed during cranking.

<p>Condition:</p> <ul style="list-style-type: none"> • Turn keyswitch ON. • Connect INSITE™ electronic service tool. • INSITE™ Monitor. 		
Action	Specification/Repair	Next Step
<p>Monitor the engine speed.</p> <ul style="list-style-type: none"> • Use INSITE™ electronic service tool to monitor engine speed while cranking the engine. <p>Attempt to start the engine; engage the engine starter for at least 30 continuous seconds.</p> <p>Do not overheat the starter.</p> <p>Attempting to start the engine for 30 continuous seconds also allows the fault code logic time to perform. If any fault codes become active, stop using this troubleshooting tree and reference the corresponding fault code troubleshooting tree.</p>	<p>Is the engine speed greater than 150 rpm during cranking?</p> <p>YES</p>	<p>3D</p>
	<p>Is the engine speed greater than 150 rpm during cranking?</p> <p>NO</p> <p>Repair:</p> <p>Find and correct the cause for low cranking speed. Consider the batteries, engine starting motor, drive units and accessory loads.</p>	<p>Refer to the Engine Will Not Crank or Cranks Slowly (Electric or Air Starter) troubleshooting symptom (TS) tree.</p>

STEP 3D: Monitor the ECM Keyswitch Input.

<p>Condition:</p> <ul style="list-style-type: none"> • Turn keyswitch ON. • Connect INSITE™ electronic service tool. • Engine not operating. 		
Action	Specification/Repair	Next Step
<p>Monitor User Fueling State.</p> <ul style="list-style-type: none"> • Use INSITE™ electronic service tool to monitor fuel state while cranking the engine. <p>If the engine is intermittently shutting down, User Fueling State can also be monitored during engine shut down.</p> <p>If the INSITE™ electronic service tool is unavailable:</p> <ul style="list-style-type: none"> • Disconnect the OEM harness. • Turn keyswitch ON. <p>Measure the signal voltage from the keyswitch input signal wire of the OEM harness to the engine block ground.</p> <p>Measure the keyswitch voltage with the keyswitch in the ON position and also with the keyswitch in the cranking position.</p> <p>Refer to the corresponding wiring diagram for the engine being serviced for connector pin identification.</p>	<p>Does the User Fueling State indicate Cranking or is the keyswitch voltage equal to battery voltage?</p> <p>YES</p>	3E
	<p>Does the User Fueling State indicate Cranking or is the keyswitch voltage equal to battery voltage?</p> <p>NO</p> <p>Repair:</p> <p>Check the keyswitch battery supply circuit. Use the following procedure in the ISB (4 cylinder) and ISBe (4 and 6 cylinder) Electronic Control System Troubleshooting and Repair manual, Bulletin 3666477. Refer to Procedure 019-064 in Section 19. Repair or replace the OEM harness, keyswitch, or check the battery connections. Refer to the OEM service manual for the proper procedures.</p>	Repair complete.

STEP 3E: Monitor the ECM Battery Supply.

<p>Condition:</p> <ul style="list-style-type: none"> • Turn keyswitch ON. • Connect INSITE™ electronic service tool. • Engine not running. 		
Action	Specification/Repair	Next Step
<p>Monitor battery voltage.</p> <ul style="list-style-type: none"> • Use INSITE™ electronic service tool to monitor battery voltage while cranking the engine. <p>If the INSITE™ electronic service tool is unavailable:</p> <ul style="list-style-type: none"> • Disconnect the ECM power supply connection. • Turn keyswitch ON. <p>Measure the voltage from the ECM battery supply (-) pin(s) to the ECM battery supply (+) pin(s) in the ECM connector.</p> <p>Measure the ECM voltage with the keyswitch in the ON position and also with the keyswitch in the cranking position.</p> <p>Refer to the corresponding wiring diagram for the engine being serviced for connector pin identification.</p>	<p>Is the ECM battery supply voltage greater than +11-VDC for 12 volt systems or +22-VDC for 24 volt systems?</p> <p>YES</p>	3F
	<p>Is the ECM battery supply voltage greater than +11-VDC for 12 volt systems or +22-VDC for 24 volt systems?</p> <p>NO</p> <p>Repair:</p> <p>Repair or replace the ECM power and ground connections. Check the battery connections and fuse terminals.</p>	Repair complete.

STEP 3F: Check the Load Carrying Capabilities of the ECM Power and Ground Circuits.

<p>Condition:</p> <ul style="list-style-type: none"> • Turn keyswitch OFF. • Disconnect the ECM Power Supply Connection. 		
Action	Specification/Repair	Next Step
<p>Connect a headlight (12 volt or 24 volt systems) A headlight must be used to make sure that the wattage rating will put enough of a load on the circuit.</p> <p>Use the ECM battery SUPPLY (+) pin in the ECM power supply connection for the battery positive (+) and the ECM battery SUPPLY (-) pin in the ECM power harness connector for the battery negative (-).</p> <p>Refer to the corresponding wiring diagram for the engine being serviced for connector pin identification.</p>	<p>Do the headlights illuminate brightly? YES</p>	3G
	<p>Do the headlights illuminate brightly? NO</p> <p>Repair: Repair or replace the ECM power and ground connections. Check the battery connections and fuse terminals.</p>	Repair complete

STEP 3G: Check orientation of connector.

<p>Condition:</p> <ul style="list-style-type: none"> • Turn keyswitch OFF. 		
Action	Specification/Repair	Next Step
<p>Check for the appropriate orientation of the rail fuel pressure sensor connector. Connector can be installed rotated 180 degrees.</p>	<p>Is the sensor correctly installed? YES</p>	3H
	<p>Is the sensor correctly installed? NO</p> <p>Repair: Reorient connector.</p>	4A

STEP 3H: Verify rail fuel pressure sensor accuracy.

<p>Condition:</p> <ul style="list-style-type: none"> • Turn keyswitch ON. • Connect INSITE™ electronic service tool. • INSITE™ electronic service tool monitor. • Engine not operating. 		
Action	Specification/Repair	Next Step
<p>Monitor the fuel rail pressure. Use INSITE™ electronic service tool to measure the fuel rail pressure.</p>	<p>Is the Fuel Rail Pressure (measured) less than 30 bar (435 psi)? YES</p>	3I
	<p>Is the Fuel Rail Pressure (measured) less than 30 bar (435 psi)? NO</p>	Repair Complete

STEP 3I: Monitor fuel rail pressure while cranking the engine.

<p>Condition:</p> <ul style="list-style-type: none"> • Turn keyswitch ON. • Connect INSITE™ electronic service tool. • INSITE™ electronic service tool monitor. 		
Action	Specification/Repair	Next Step
<p>Monitor Fuel Rail Pressure (measured) and Fuel Rail Pressure (commanded). Use INSITE™ electronic service tool. Fuel Rail Pressure (commanded) can also be referred to as HPCR fuel setpoint. Attempt to start the engine, engage the engine starter for at least 30 continuous seconds. Do not overheat the starter. A minimum of 100 bar [1450 psi] of fuel rail pressure is required before the injectors will open and provide fuel. Attempting to start the engine for 30 continuous seconds allows the fault code logic time to run. If Fault Code 2215 or 559 becomes active, adequate fuel rail pressure is not being developed. Discontinue using this troubleshooting tree and troubleshoot Fault Code 2215 or 559.</p>	<p>Did the Fuel Rail Pressure (measured) equal the Fuel Rail Pressure (commanded)? YES</p>	5A
	<p>Did the Fuel Rail Pressure (measured) equal the Fuel Rail Pressure (commanded)? NO</p>	4A

STEP 4: Fuel system troubleshooting procedures.

STEP 4A: Check for air in the fuel supply line.

Condition:

- Turn keyswitch OFF.
- Engine OFF.
- Connect required service tools at the fuel filter head diagnostic port (inlet).
- Turn keyswitch ON.

Action	Specification/Repair	Next Step
<p>Check for air in the fuel.</p> <p>Use the following procedure in the ISBe, ISB, and QSB (Common Rail Fuel System) Service Manual, Bulletin 4021271. Refer to Procedure 006-003 in Section 6.</p> <p>Operate the fuel lift pump.</p> <p>At initial key ON, the lift pump will run for 60 seconds and then turn OFF. The lift pump can also be operated, use INSITE™ electronic service tool lift pump override test.</p>	<p>Is air present in the fuel supply?</p> <p>YES</p> <p>Repair:</p> <p>Locate and correct the cause of air ingestion in the fuel supply system. Sources of air ingestion include loose fuel filters, loose fuel line fittings, loose or cracked fuel tank stand-pipes, or severe restrictions in the fuel supply lines and filters that cause cavitation at high fuel flow rates.</p>	<p>Repair complete</p>
	<p>Is air present in the fuel supply?</p> <p>NO</p>	<p>4B</p>

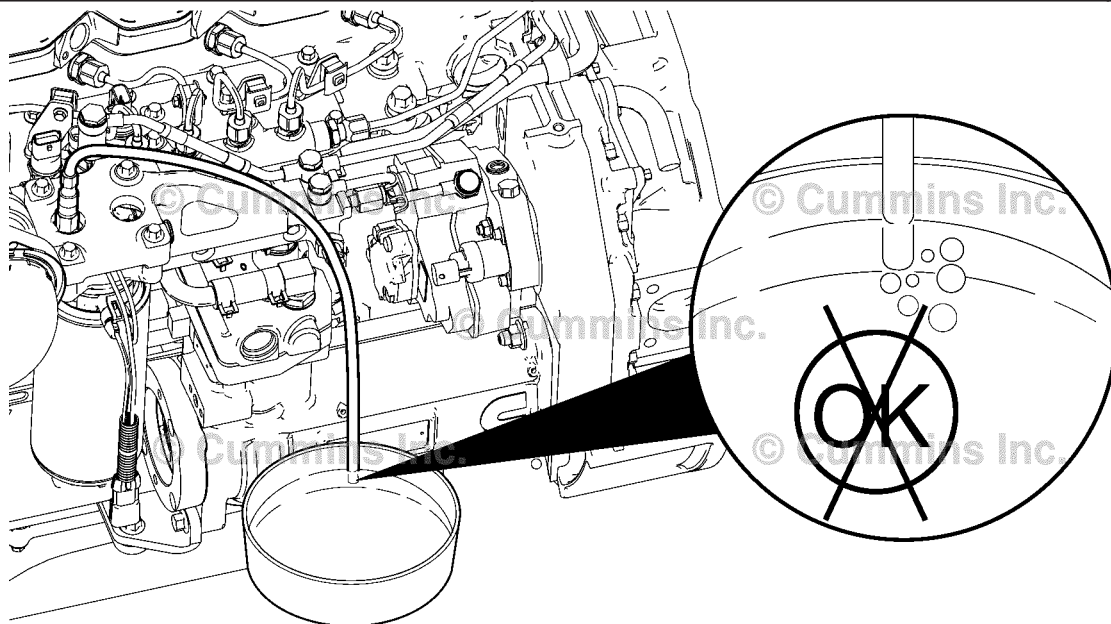

00d00080

STEP 4B: Measure fuel flow/pressure at the inlet of the on engine fuel filter.

Condition:

- Turn keyswitch OFF.
- Engine OFF.
- Connect required service tools at the fuel filter head diagnostic port (inlet).
- Turn keyswitch ON.

Action	Specification/Repair	Next Step
<p>Measure fuel inlet pressure and flow at the inlet diagnostic port of the fuel filter.</p> <p>Use the following procedure(s) in the ISBe, ISB, and QSB (Common Rail Fuel System) Service Manual, Bulletin 4021271. Refer to Procedure 005-045 in Section 5. Refer to Procedure 006-015 in Section 6.</p> <p>Operate the fuel lift pump.</p> <p>At initial key ON, the lift pump will run for 60 seconds and then turn OFF. The lift pump can also be operated, use INSITE™ electronic service tool lift pump override test.</p> <p>Fuel flow rate for lift pump (engine not operating) - greater than 300 ml in 30 seconds.</p> <p>Measure the pressure at high idle:</p> <ul style="list-style-type: none"> • Fuel pressure range lift pump (engine operating) - 0 to 0.8 bar [0 to 11.6 psi]. <p>Record the fuel filter inlet flow and pressure measured.</p>	<p>Was the pressure/flow measured within specification?</p> <p>NOTE: Record the measured fuel inlet pressure for use in the next step.</p> <p>YES</p>	4E
	<p>Was the pressure/flow measured within specification?</p> <p>NO</p>	4C

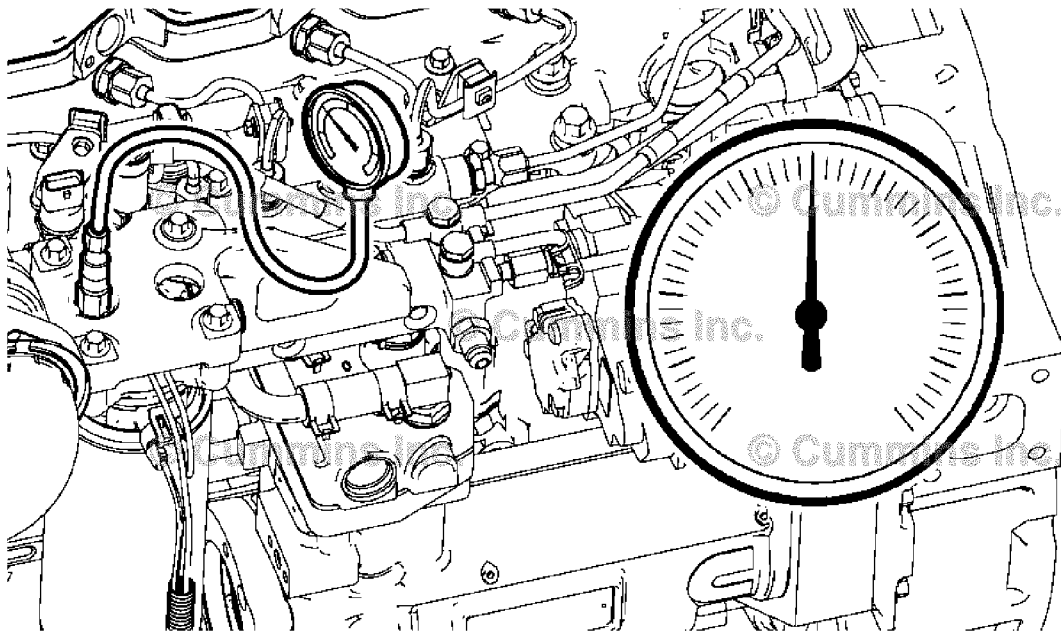

19d02005

STEP 4C: Measure the fuel inlet restriction.

Condition:

- Turn keyswitch OFF.
- Engine OFF.
- Connect required service tools at the fuel lift pump inlet.

Action	Specification/Repair	Next Step
<p>Measure the fuel inlet restriction.</p> <p>Use the following procedure in the ISBe, ISB, and QSB (Common Rail Fuel System) Service Manual, Bulletin 4021271. Refer to Procedure 006-020 in Section 6.</p> <p>Operate the engine at high idle:</p> <p>Maximum inlet restriction - 6 in-Hg (vacuum) 20.3 kPa</p> <p>If the engine will not start, operate the lift pump, use INSITE™ electronic service tool Fuel Lift Pump Override Test.</p> <p>If the issue is intermittent (no start or engine shuts off unexpectedly) and no issues can be found while the engine is being serviced, there may be debris in the fuel system causing an intermittent restriction. Install a fuel filter minder, Fleetguard® Part Number 3892576s, at the connection between the OEM fuel supply lines and the engine. A fuel filter minder will capture the peak restriction in millimeters and inches of mercury. If the issue occurs again, the fuel filter minder can be checked to see if there is something on the OEM side causing an intermittent high restriction.</p>	<p>Is the fuel inlet restriction greater than the specification?</p> <p>YES</p> <p>Repair:</p> <p>Find and correct cause of high inlet restriction. Look for plugged OEM fuel filters or screens, or a restricted ECM cooler, pinched OEM fuel lines or a restricted stand pipe in the OEM fuel tank.</p> <hr/> <p>Is the fuel inlet restriction greater than the specification?</p> <p>NO</p>	<p>Repair Complete.</p> <hr/> <p>4D</p>

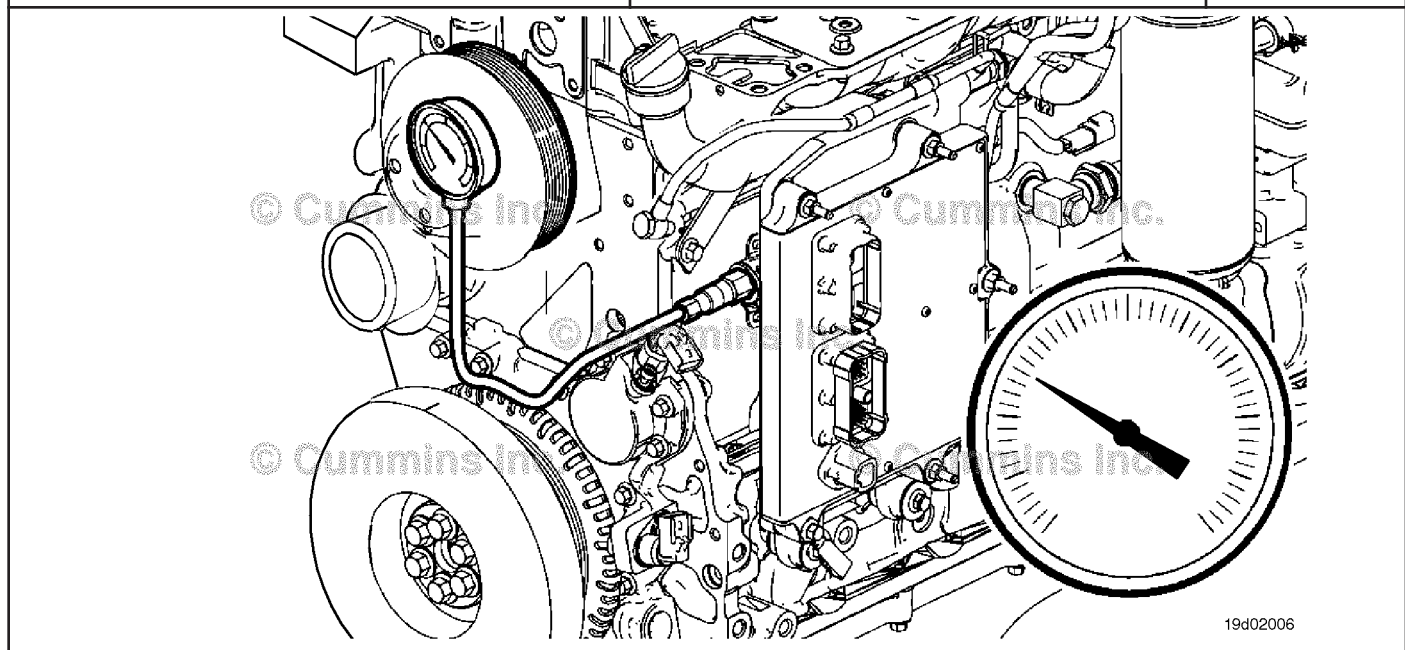

STEP 4D: Check if the engine is equipped with a lift pump voltage regulator.

Condition: N/A		
Action	Specification/Repair	Next Step
Check if the engine is equipped with an on engine voltage regulator to convert 24 volts to 12 volts. This allows for the use of a 12 volt lift pump in a 24 volt engine configuration. If equipped, the voltage regulator is mounted below the ECM.	Is the engine equipped with a lift pump voltage regulator? YES Repair: If equipped, verify the voltage regulator is operating properly. Replace if necessary. If OK, replace the electric fuel lift pump. Use the following procedure in the ISBe, ISB, and QSB (Common Rail Fuel System) Service Manual, Bulletin 4021271. Refer to Procedure 005-045 in Section 5.	Repair Complete
	Is the engine equipped with a lift pump voltage regulator? NO Repair: Replace the electric fuel lift pump. Use the following procedure in the ISBe, ISB, and QSB (Common Rail Fuel System) Service Manual, Bulletin 4021271. Refer to Procedure 005-045 in Section 5.	Repair Complete

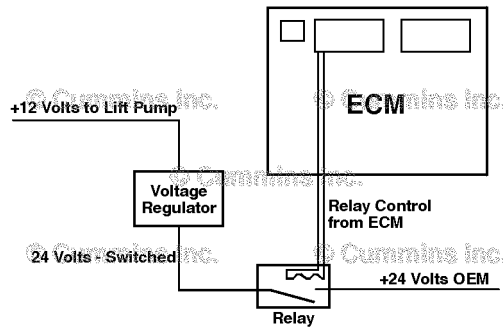

05d00768

STEP 4E: Measure fuel pressure at the outlet of the on engine fuel filter

Condition:

- Turn keyswitch OFF.
- Connect required service tools at the fuel filter head diagnostic port(outlet).
- Turn keyswitch ON.

Action	Specification/Repair	Next Step
<p>Measure fuel outlet pressure outlet diagnostic port of the fuel filter.</p> <p>Use the following procedure in the ISBe, ISB, and QSB (Common Rail Fuel System) Service Manual, Bulletin 4021271. Refer to Procedure 006-015 in Section 6.</p> <p>Calculate the pressure drop across the fuel filter by subtracting the pressure measured here from the pressure measured in Step 4B.</p> <p>Measure the pressure at low idle:</p> <ul style="list-style-type: none"> • Maximum pressure drop across the fuel filter - 0.35 bar [5 psi]. <p>If the engine will not start, use INSITE™ electronic service tool Fuel Lift Pump Override Test to operate the lift pump.</p>	<p>Is the pressure drop across the filter greater than the specification?</p> <p>YES</p> <p>Repair:</p> <p>Replace the fuel filter. Use the following procedure in the ISBe, ISB, and QSB (Common Rail Fuel System) Service Manual, Bulletin 4021271. Refer to Procedure 006-015 in Section 6.</p>	<p>Repair complete</p>
	<p>Is the pressure drop across the filter greater than the specification?</p> <p>NO</p>	<p>4F</p>

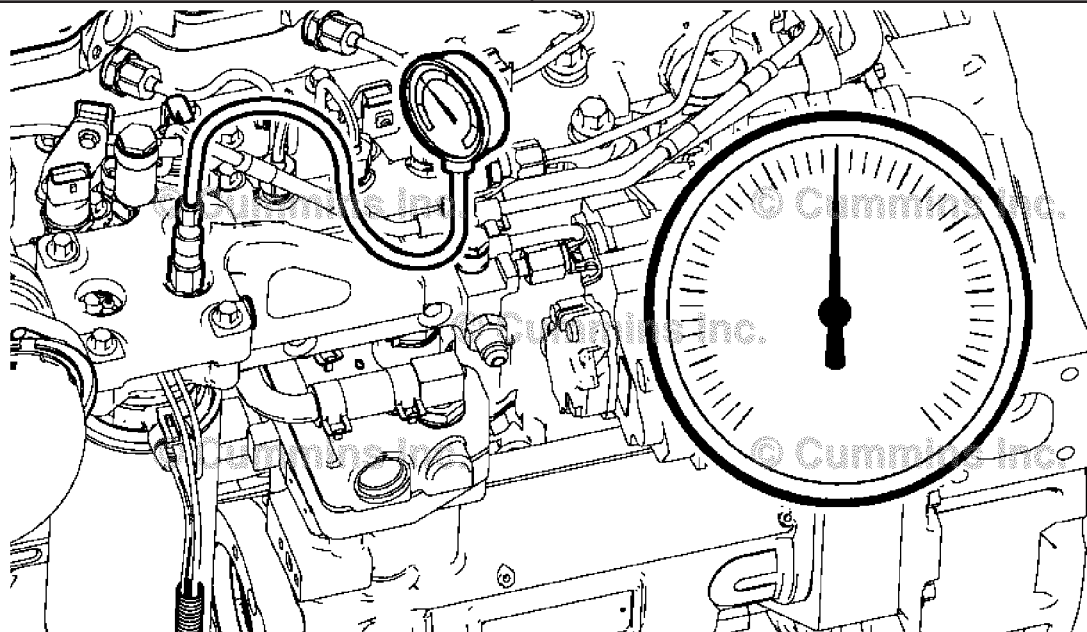

19d02004

STEP 4F: Perform INSITE™ electronic service tool single cylinder cutout test.

<p>Condition:</p> <ul style="list-style-type: none"> • Turn keyswitch ON. • Engine operating at low idle. • Connect INSITE™ electronic service tool. 		
Action	Specification/Repair	Next Step
<p>Perform single cylinder cutout test.</p> <p>If the engine will not start or is difficult to start, move to the next step.</p> <ul style="list-style-type: none"> • In the ECM Diagnostic Tests menu of INSITE™ electronic service tool, click on the Cylinder Cutout Test, and follow the instructions on the screen. • Operate the engine under the conditions in which the complaint occurs. • Use INSITE™ electronic service tool to perform the Cylinder Cutout Test to disable individual injectors. <p>If this test is performed and there is not a significant change while cutting out one injector, there may be a problem with more than one injector. It may be necessary to cut out multiple cylinders at a time.</p>	<p>Can the miss or excessive smoke be attributed to a single cylinder?</p> <p>YES</p> <p>Repair:</p> <p>Look for a cause of the complaint, including valve lash and excessive crankcase pressure that may indicate power cylinder damage, or camshaft lobe wear. If no other damage is found, replace the fuel injector in the cylinder that was identified using the single cylinder cut-out test. Use the following procedure in the ISBe, ISB, and QSB (Common Rail Fuel System) Service Manual, Bulletin 4021271. Refer to Procedure 006-026 in Section 6.</p>	<p>Repair complete</p>
	<p>Can the miss or excessive smoke be attributed to a single cylinder?</p> <p>NO</p>	<p>4G</p>

STEP 4G: Perform a manual single cylinder cut-out test.

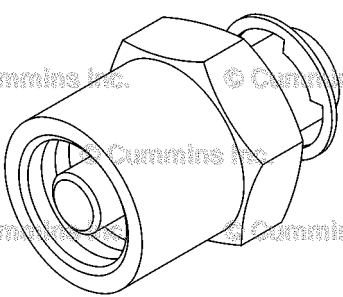
Condition:		
<ul style="list-style-type: none"> • Turn keyswitch OFF. • Install the injector leakage isolation too. • Turn keyswitch ON. 		
Action	Specification/Repair	Next Step
<p>Perform a manual cut-out test.</p> <ul style="list-style-type: none"> • With the engine not operating, disconnect the fuel line running from the rail to cylinder number 1. Use the following procedure in the ISBe, ISB, and QSB (Common Rail Fuel System) Service Manual, Bulletin 4021271. Refer to Procedure 006-051 in Section 6. • Install the injector leakage isolation tools. <p>For 3.9L and 5.9L engines, install the injector leakage isolation tool, Part Number 3164325, on the rail where the number 1 cylinder fuel line connects.</p> <p>Torque Value: 30 N•m [22 ft-lb].</p> <p>Attempt to start the engine or operate the engine at idle.</p> <p>Repeat the above test, as necessary, with each cylinder blocked off.</p>	<p>Did the engine start after blocking off a cylinder(s) or can the miss or excessive smoke be attributed to a cylinder(s)?</p> <p>YES</p> <p>Repair:</p> <p>Look for a cause of the complaint, including valve lash and excessive crankcase pressure that can indicate power cylinder damage or camshaft lobe wear. If no other damage is found, replace the fuel injector in the cylinder that was identified using the manual single cylinder cut-out test. Use the following procedure in the ISBe, ISB, and QSB (Common Rail Fuel System) Service Manual, Bulletin 4021271. Refer to Procedure 006-051 in Section 6.</p>	Repair complete
	<p>Did the engine start after blocking off a cylinder(s) or can the miss or excessive smoke be attributed to a cylinder(s)?</p> <p>NO</p>	4H
 <p>© Cummins Inc. © Cummins Inc. © Cummins Inc. © Cummins Inc. © Cummins Inc. © Cummins Inc.</p> <p>06d00259</p>		

STEP 4H: Measure the injector return fuel drain flow from the cylinder head.

Condition:

- Turn keyswitch OFF.
- Connect appropriate service tools to measure injector fuel drain flow from the cylinder head.

Action	Specification/Repair	Next Step
Measure the injector return fuel drain flow from the cylinder head. Use the following procedure in the ISBe, ISB, and QSB (Common Rail Fuel System) Service Manual, Bulletin 4021271. Refer to Procedure 006-051 in Section 6. Flow Specification: Idle Conditions 6 cylinder engines - 180 ml/minute [6 fl-oz per minute] maximum Cranking Conditions Make sure not to overheat the starter 6 cylinder engines - 90 ml/minute [3 fl-oz per minute] maximum	Is injector fuel drain flow from the cylinder head greater than specification? YES	4I
	Is injector fuel drain flow from the cylinder head greater than specification? NO	4J

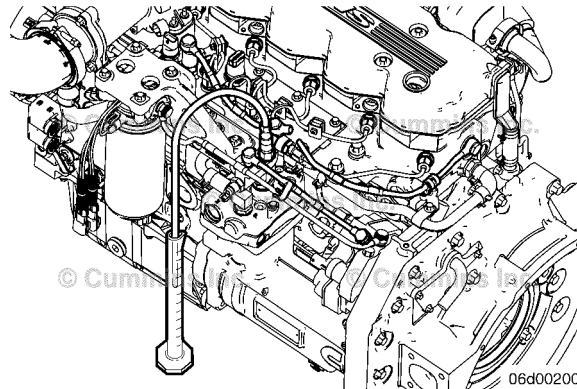

STEP 4I: Determine which cylinder(s) is causing excessive injector fuel drain flow from the cylinder head.

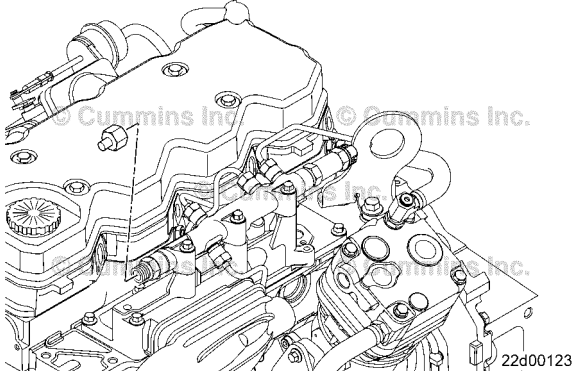
Action	Specification/Repair	Next Step
<p>Condition:</p> <ul style="list-style-type: none"> • Turn keyswitch OFF. • Connect appropriate service tools to measure injector fuel drain flow from the cylinder head. • Install the injector leakage isolation tool. <p>Measure the injector return fuel drain flow from the cylinder head and isolate a cylinder one at a time using the injector leakage isolation tool.</p> <p>Use the following procedure in the ISBe, ISB, and QSB (Common Rail Fuel System) Service Manual, Bulletin 4021271. Refer to Procedure 006-051 in Section 6.</p> <p>The flow rate will decrease below the maximum specified flow when the cylinder with the leak is blocked.</p> <p>Flow Specification:</p> <p>Idle Conditions 6 cylinder engines - 180 ml/minute [4 fl-oz per minute] maximum.</p> <p>Cranking Conditions</p> <p>Make sure not to overheat the starter</p> <p>6 cylinder engines - 90 ml/minute [3 fl-oz per minute] maximum.</p> <p>If this test is performed and there is not a significant change in fuel return flow while cutting out one injector, there may be a problem with more than one injector. Compare the fuel flow difference across all injectors. Is there more than one injector that caused a noticeable decrease in fuel flow? If so, these could be the injectors with the problems.</p> <p>Another cause of this problem could be that the customer is operating on fuels lighter than specified. Fuels with low viscosity will result in higher injector leakage and greater drain flow rates.</p>	<p>Did blocking off a cylinder(s) decrease the flow rate below the maximum specified flow rate?</p> <p>YES</p> <p>Repair:</p> <p>Remove the fuel connector and inspect for damage. Replace if necessary.</p> <p>Remove the injector and inspect the fuel connector contact surface for damage. Replace if necessary.</p> <p>Use the following procedure(s) in the ISBe, ISB, and QSB (Common Rail Fuel System) Service Manual, Bulletin 4021271. Refer to Procedure 006-051 in Section 6. Refer to Procedure 006-052 in Section 6.</p> <hr/> <p>Did blocking off a cylinder(s) decrease the flow rate below the maximum specified flow rate?</p> <p>NO</p>	<p>Repair Complete</p> <hr/> <p>4J</p>
		

STEP 4J: Monitor Commanded Fuel Rail Pressure and Measured Fuel Rail Pressure.

<p>Condition:</p> <ul style="list-style-type: none"> • Turn keyswitch ON. • Electronic service tool connected. • Engine idling. 		
Action	Specification/Repair	Next Step
<p>Use an electronic service tool to monitor Commanded Fuel Rail Pressure and Measured Fuel Rail Pressure while the engine is idling.</p> <p>When monitoring, note whether any engine driven accessory (air conditioning compressor, air compressor, fan clutch, etc.) turns on. Also, note whether any accessories that put demand/load on the alternator (intake air heater, vehicle accessories, etc.). These items can affect the outcome of this check. The load on the engine should be constant.</p>	<p>Does the Measured Fuel Rail Pressure vary more than ± 35 bar [± 500 psi] from the Commanded Fuel Rail Pressure?</p> <p>YES</p> <p>Repair:</p> <p>Replace the fuel pump actuator. Use the following procedure in the ISB, ISBe, ISBe4, QSB4.5, QSB5.9, and QSB6.7 (Common Rail Fuel System) Service Manual, Bulletin 4021271. Refer to Procedure 005-007 in Section 5.</p>	Repair complete
	<p>Does the Measured Fuel Rail Pressure vary more than ± 35 bar [± 500 psi] from the Commanded Fuel Rail Pressure?</p> <p>NO</p>	4K

STEP 4K: Check the fuel pressure relief valve for excessive leakage.

<p>Condition:</p> <ul style="list-style-type: none"> • Use the following procedure in the ISBe, ISB, and QSB (Common Rail Fuel System) Service Manual, Bulletin 4021271. Refer to Procedure 006-061 in Section 6. 		
Action	Specification/Repair	Next Step
<p>Measure the fuel pressure relief valve drain flow.</p> <p>Use the following procedure in the Service Manual, ISBe, ISB, and QSB (Common Rail Fuel System) Series Engines, Bulletin 4021271. Refer to Procedure 006-061 in Section 6.</p>	<p>Is the fuel pressure relief valve within specification?</p> <p>YES</p>	4L
	<p>Is the fuel pressure relief valve within specification?</p> <p>NO</p> <p>Repair:</p> <p>Replace the fuel pressure relief valve. Use the following procedure in the ISBe, ISB, and QSB (Common Rail Fuel System) Service Manual, Bulletin 4021271. Refer to Procedure 006-061 in Section 6.</p>	Repair complete

STEP 4L: Measure the high-pressure fuel supply pump fuel drain flow.

Condition: • Use the following procedure in the ISBe, ISB, and QSB (Common Rail Fuel System) Service Manual, Bulletin 4021271. Refer to Procedure 005-016 in Section 5.		
Action	Specification/Repair	Next Step
Measure the high-pressure fuel supply pump return flow. Use the following procedure in the ISBe, ISB, and QSB (Common Rail Fuel System) Service Manual, Bulletin 4021271. Refer to Procedure 005-016 in Section 5.	Is the high-pressure fuel supply pump fuel drain flow greater than specification? YES Repair: Replace the high-pressure fuel supply pump. Use the following procedure in the ISBe, ISB, and QSB (Common Rail Fuel System) Service Manual, Bulletin 4021271. Refer to Procedure 005-016 in Section 5.	Repair complete
	Is the high-pressure fuel supply pump fuel drain flow greater than specification? NO	4M

STEP 4M: Measure fuel drain line restriction.

Condition:

- Turn keyswitch OFF.
- Connect appropriate service tools to measure fuel drain line restriction.

Action	Specification/Repair	Next Step
Measure the fuel drain line restriction. Use the following procedure in the ISBe, ISB, and QSB (Common Rail Fuel System) Service Manual, Bulletin 4021271. Refer to Procedure 006-012 in Section 6.	Is the drain line restriction less than specification? YES	Perform next troubleshooting procedure as outlined in Step 2.
Operate the engine at high idle: Maximum fuel drain line restriction: 0.19 bar (2.7 psi).	Is the drain line restriction less than specification? NO Repair: Check OEM fuel drain lines to tank for proper size, leaks, bends, clogs and fuel tank vents for plugging.	Repair Complete

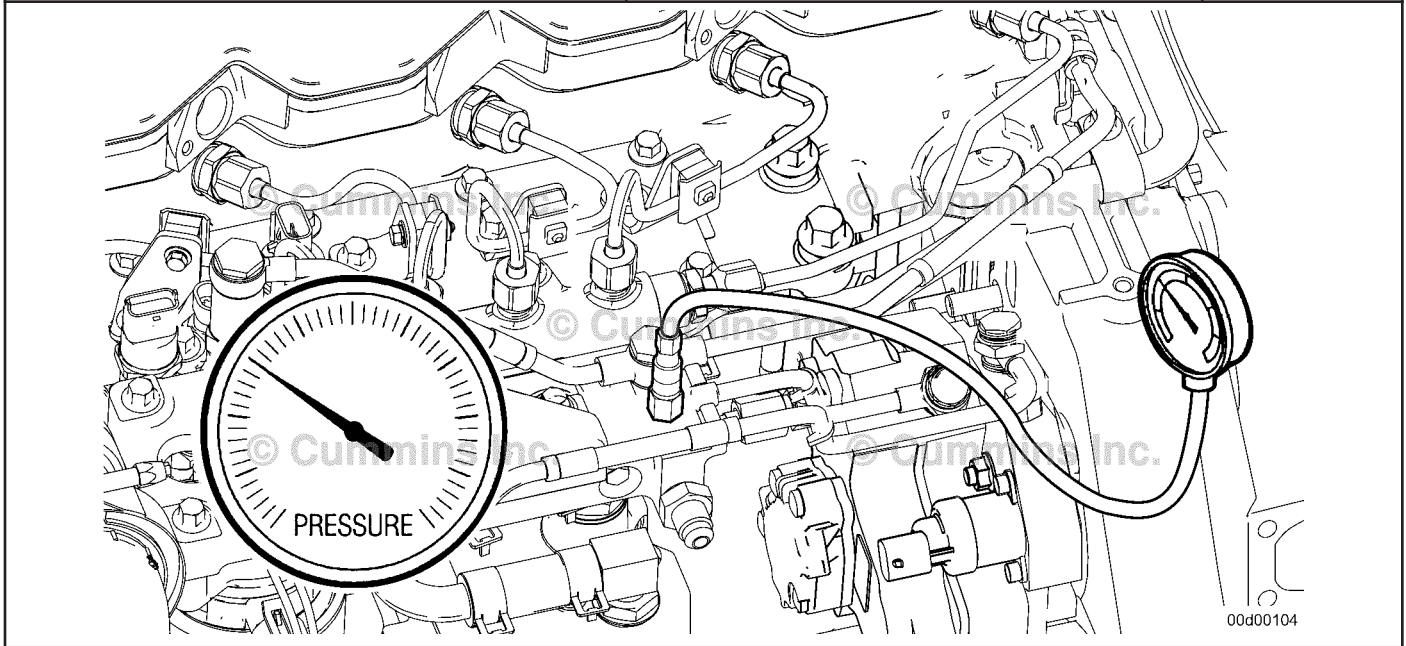

STEP 5: Air handling troubleshooting procedures.

STEP 5A: Check intake manifold pressure sensor accuracy.

<p>Condition:</p> <ul style="list-style-type: none"> • Turn keyswitch ON. • Connect INSITE™ electronic service tool. • Engine OFF. 		
Action	Specification/Repair	Next Step
<p>Start the data monitor/logger and monitor reading.</p> <p>Start INSITE™ electronic service tool data monitor/logger and monitor INSITE™ electronic service tool reading for intake manifold pressure with the engine off.</p>	<p>Intake manifold pressure reading is less than 102 mm-Hg [4 in-Hg]?</p> <p>YES</p>	5B
	<p>Intake manifold pressure reading is less than 102 mm-Hg [4 in-Hg]?</p> <p>NO</p> <p>Repair:</p> <p>Replace the intake manifold pressure sensor. Use the following procedure in the ISB (4 cylinder) and ISBe (4 and 6 cylinder) Electronic Control System Troubleshooting and Repair manual, Bulletin 3666477. Refer to Procedure 019-061 in Section 19. If equipped with a combination Intake Manifold Pressure/Temperature Sensor, use the following procedure in the ISB (4 cylinder) and ISBe (4 and 6 cylinder) Electronic Control System Troubleshooting and Repair manual, Bulletin 3666477. Refer to Procedure 019-159 in Section 19.</p>	Repair complete

STEP 5B: Check the air intake system for leaks.

<p>Condition:</p> <p>N/A</p>		
Action	Specification/Repair	Next Step
<p>Check the air intake system for leaks.</p> <p>Use the following procedure in the ISBe, ISB, and QSB (Common Rail Fuel System) Service Manual, Bulletin 4021271. Refer to Procedure 010-024 in Section 10.</p> <p>On engines equipped with a turbocharged air compressor, one often overlooked item as a source for air leaks is the air compressor intake line. The intake line supplies intake air from the intake of the engine to the air compressor.</p>	<p>Were any air intake system leaks found?</p> <p>YES</p> <p>Repair:</p> <p>Repair or replace the damaged component.</p>	Repair Complete.
	<p>Were any air intake system leaks found?</p> <p>NO</p>	5C

STEP 5C: Check air intake restriction.

Condition:

- Turn keyswitch ON.
- Engine operating at rated speed and full load.

Action	Specification/Repair	Next Step
Check the air intake restriction. • Install a vacuum gauge, Part Number ST-1111-3, or equivalent, into the air intake system. Use the following procedure in the ISBe, ISB, and QSB (Common Rail Fuel System) Service Manual, Bulletin 4021271. Refer to Procedure 010-031 in Section 10. Maximum Air Intake Restriction: Dirty Filter: 25 in-H ₂ O/635 mm-H ₂ O. Clean Filter: 10 in-H ₂ O/254 mm-H ₂ O.	Is the air intake restriction greater than the specification? YES Repair: Correct the cause of high intake air restriction. Check for a plugged air filter or restricted air intake piping.	Repair Complete
	Is the air intake restriction greater than the specification? NO	5D

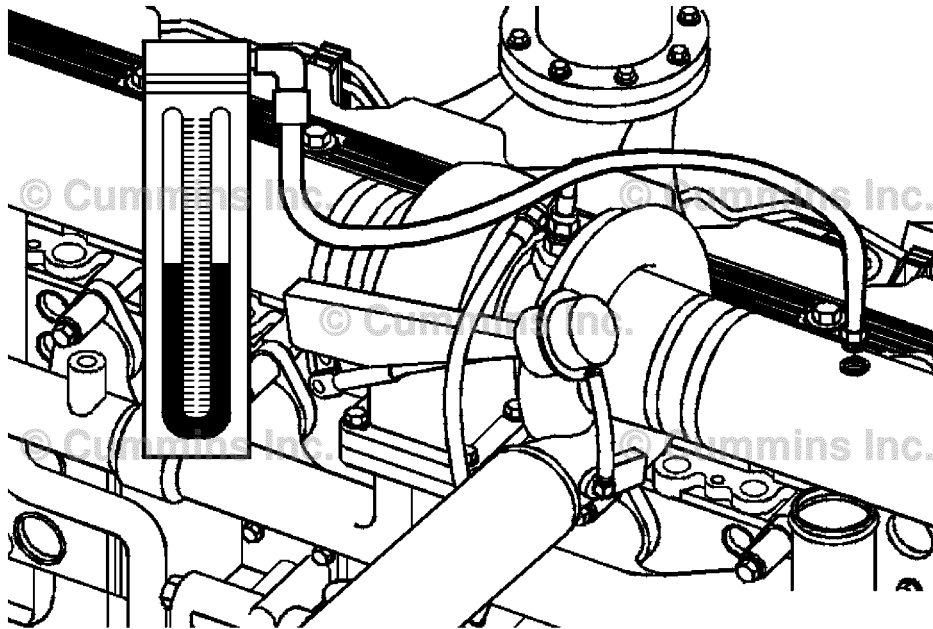

00d00109

STEP 5D: Inspect the turbocharger blades for damage.

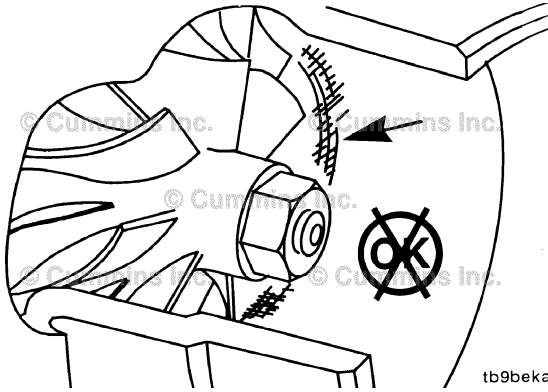
Condition: <ul style="list-style-type: none"> • Engine OFF. • Remove the intake piping from the turbocharger. 		
Action	Specification/Repair	Next Step
Inspect the compressor blades for damage or wear. Use the following procedure in the ISBe, ISB, and QSB (Common Rail Fuel System) Service Manual, Bulletin 4021271. Refer to Procedure 010-033 in Section 10.	Damage found on the turbocharger blades? YES Repair: Replace the turbocharger. Use the following procedure in the ISBe, ISB, and QSB (Common Rail Fuel System) Service Manual, Bulletin 4021271. Refer to Procedure 010-033 in Section 10.	Repair complete
	Damage found on the turbocharger blades? NO	5E
 <p>The diagram shows a cross-section of a turbocharger compressor housing. An arrow points to the compressor blades. A 'no' symbol (a circle with a diagonal slash) is placed over the blades, indicating that damage to the blades is not acceptable. The diagram is labeled 'tb9beka' in the bottom right corner.</p>		

STEP 5E: Determine if the turbocharger is a variable geometry turbocharger.

Condition: N/A		
Action	Specification/Repair	Next Step
Determine if the turbocharger is a variable geometry turbocharger. N/A	Is the turbocharger a variable geometry turbocharger? YES	5F
	Is the turbocharger a variable geometry turbocharger? NO	5G

STEP 5F: Perform INSITE™ electronic service tool turbocharger actuator test.

<p>Condition:</p> <ul style="list-style-type: none"> • Turn keyswitch ON. • Connect INSITE™ electronic service tool. 		
Action	Specification/Repair	Next Step
<p>Select turbocharger actuator test.</p> <ul style="list-style-type: none"> • In the ECM Diagnostic Tests menu of INSITE™ electronic service tool click on the turbocharger actuator test, and follow the instructions on the screen. • Open and close the turbocharger actuator. <p>When opened, the actuator position will be 100 percent open.</p> <p>When closed, the actuator position will be less than 10 percent closed.</p>	<p>Does the turbocharger pass the turbocharger actuator test?</p> <p>YES</p>	Step 5I
	<p>Does the turbocharger pass the turbocharger actuator test?</p> <p>NO</p> <p>Repair:</p> <p>Replace the variable geometry turbocharger. Use the following procedure in the ISBe, ISB, and QSB (Common Rail Fuel System) Service Manual, Bulletin 4021271. Refer to Procedure 010-033 in Section 10.</p>	Repair complete

STEP 5G: Inspect the wastegate actuator hose.

Condition:

- Engine OFF.
- Remove turbocharger if wastegate actuator is inaccessible.

Action	Specification/Repair	Next Step
Inspect the integral wastegate actuator hose for cracks or holes. Use the following procedure in the ISBe, ISB, and QSB (Common Rail Fuel System) Service Manual, Bulletin 4021271. Refer to Procedure 010-050 in Section 10.	Holes or cracks found in the wastegate actuator hose? YES Repair: Replace the wastegate actuator hose. Use the following procedure in the ISBe, ISB, and QSB (Common Rail Fuel System) Service Manual, Bulletin 4021271. Refer to Procedure 010-050 in Section 10.	Repair complete
	Holes or cracks found in the wastegate actuator hose? NO	5H

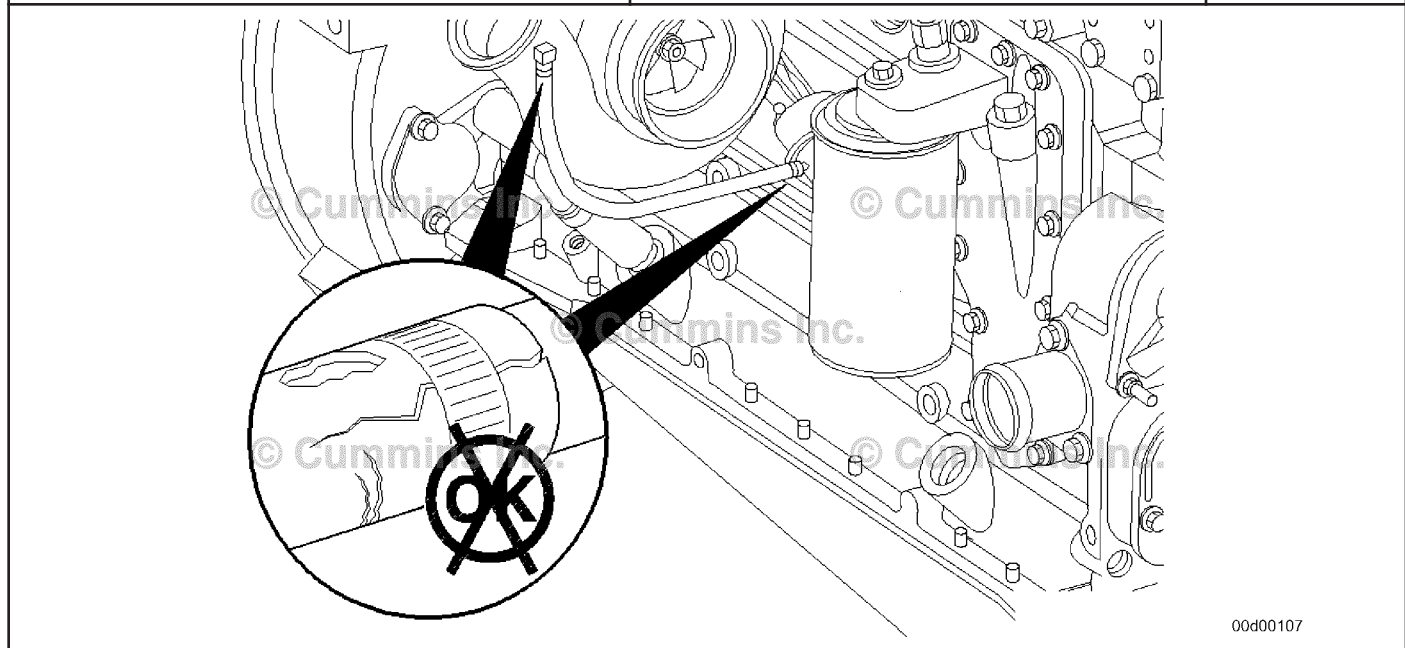

00d00107

STEP 5H: Inspect the turbocharger wastegate capsule for air leaks.

Condition:

- Engine OFF.
- Remove the wastegate actuator hose from the wastegate actuator.

Action	Specification/Repair	Next Step
Perform a leak test on the wastegate actuator capsule. Refer to Procedure 010-050 in Section 10 of the Service Manual, ISBe, ISB, QSB (Common Rail Fuel System), Bulletin 4021271. Use Cummins® tool, Part Number 3823799, to apply a regulated air supply of 59 in-Hg (29 psi) to the wastegate actuator capsule. No air should be heard (i.e., leaking noise) through a functional wastegate capsule.	Did the wastegate actuator capsule leak air? YES Repair: Replace the wastegate actuator. Use the following procedure in the ISBe, ISB, and QSB (Common Rail Fuel System) Service Manual, Bulletin 4021271. Refer to Procedure 010-050 in Section 10.	Repair complete
	Did the wastegate actuator capsule leak air? NO	5H-1

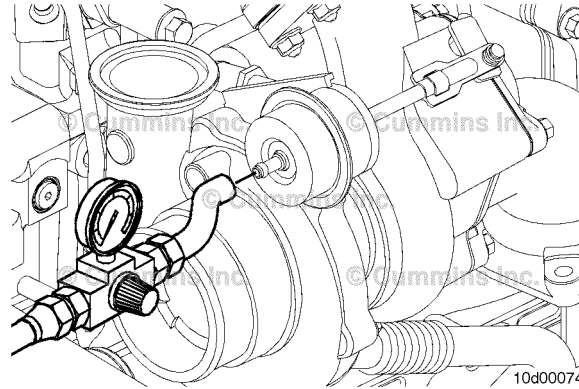

STEP 5H-1: Inspect the turbocharger wastegate actuator for proper operation.

Condition:

- Engine OFF.
- Remove the wastegate actuator hose from the wastegate actuator.

Action	Specification/Repair	Next Step
Check the wastegate actuator rod for movement. Use the following procedure in the ISBe, ISB, and QSB (Common Rail Fuel System) Service Manual, Bulletin 4021271. Refer to Procedure 010-050 in Section 10. Use Cummins® tool, Part Number 3823799, to apply a regulated air supply of 59 in-Hg (29 psi) to the wastegate actuator capsule. Check for wastegate actuator rod for movement.	Does the wastegate actuator rod move? YES	Step 5I
	Does the wastegate actuator rod move? NO	Step 5H-2

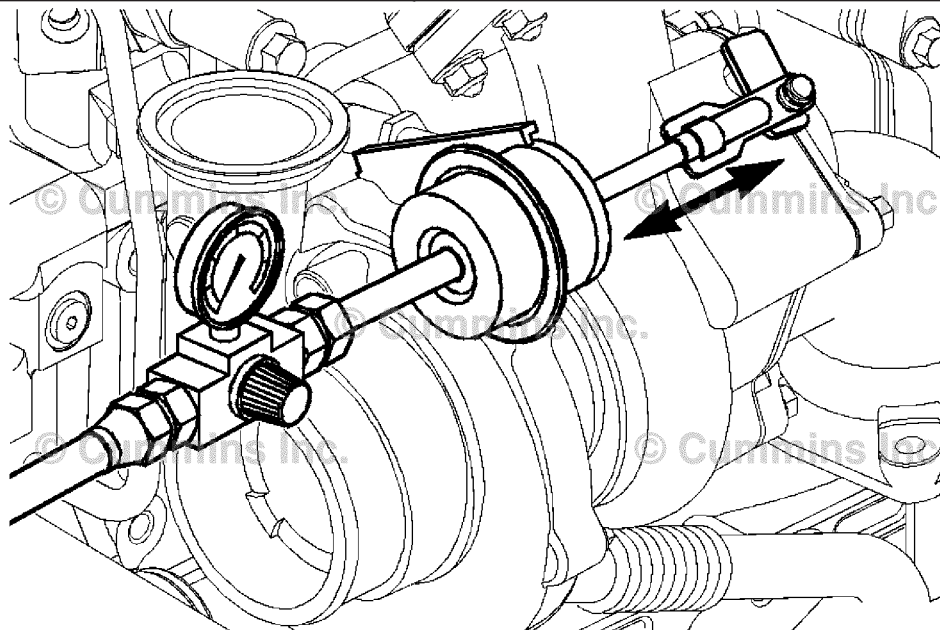

00d00106

STEP 5H-2: Inspect the turbocharger wastegate for proper operation.

Condition:

- Engine OFF.
- Remove the e-clip from the wastegate pin and disconnect the actuator rod from the wastegate lever.

Action	Specification/Repair	Next Step
<p>Check the wastegate actuator rod for movement with it disconnected from the turbocharger wastegate.</p> <p>Use the following procedure in the ISBe, ISB, and QSB (Common Rail Fuel System) Service Manual, Bulletin 4021271. Refer to Procedure 010-050 in Section 10.</p> <p>Use Cummins® Tool Part Number 3823799 to apply a regulated air supply of 59 in-Hg (29 psi) to the wastegate actuator capsule. Check for wastegate actuator rod for movement.</p>	<p>Does the wastegate actuator rod move? YES</p> <p>Repair:</p> <p>Move the wastegate lever back and forth and check for smooth operation. If the wastegate lever does not move freely or binds, spray a penetrating oil on the wastegate lever joint and try to free the wastegate lever by working the lever back and forth. If the lever does not become free, replace the turbocharger. Use the following procedure in the ISBe, ISB, and QSB (Common Rail Fuel System) Service Manual, Bulletin 4021271. Refer to Procedure 010-033 in Section 10.</p>	<p>Repair Complete.</p>
	<p>Does the wastegate actuator rod move? NO</p> <p>Repair:</p> <p>Replace the wastegate actuator. Use the following procedure in the ISBe, ISB, and QSB (Common Rail Fuel System) Service Manual, Bulletin 4021271. Refer to Procedure 010-050 in Section 10.</p>	<p>Repair Complete.</p>

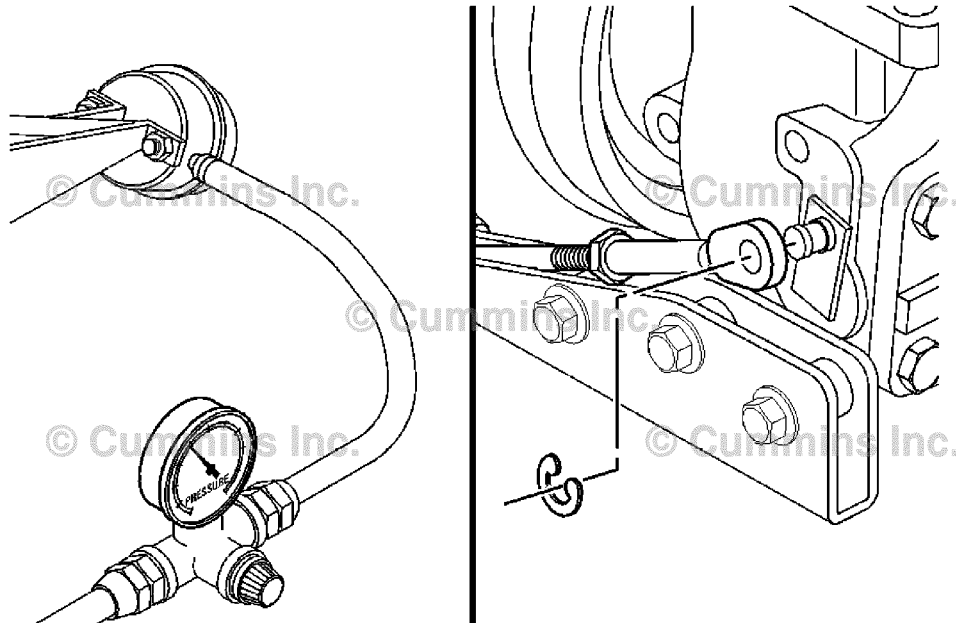

00d00108

STEP 5I: Measure turbocharger axial and radial clearance.

<p>Condition:</p> <ul style="list-style-type: none"> • Engine OFF. • Disconnect the exhaust and intake connections from the turbocharger. 		
Action	Specification/Repair	Next Step
<p>Follow the procedure for measuring the axial clearance of the turbocharger.</p> <p>Use the following procedure in the ISBe, ISB, and QSB (Common Rail Fuel System) Service Manual, Bulletin 4021271. Refer to Procedure 010-033 in Section 10.</p>	<p>Are the axial and radial clearances within specification?</p> <p>YES</p>	<p>5J</p>
	<p>Are the axial and radial clearances within specification?</p> <p>NO</p> <p>Repair:</p> <p>Replace the turbocharger assembly. Use the following procedure in the ISBe, ISB, and QSB (Common Rail Fuel System) Service Manual, Bulletin 4021271. Refer to Procedure 010-033 in Section 10.</p>	<p>Repair Complete</p>

STEP 5J: Inspect the charge-air cooler.

Condition:

- Turn keyswitch OFF.

Action	Specification/Repair	Next Step
Inspect the charge air cooler for cleanliness, blockage, cracks, holes, or other damage. <ul style="list-style-type: none"> • Use the following procedure in the ISBe, ISB, and QSB (Common Rail Fuel System) Service Manual, Bulletin 4021271. Refer to Procedure 010-027 in Section 10. The pressure and temperature checks in the chargeair cooler procedure can be used to verify charge-air cooler problems.	Does the charge-air cooler pass the visual inspection as well as the pressure test and temperature differential test? YES	Perform the next troubleshooting procedure as outlined in Step 2.
	Does the charge-air cooler pass the visual inspection as well as the pressure test and temperature differential test? NO Repair: Repair or replace the charge-air cooler assembly. Use the following procedure in the ISBe, ISB, and QSB (Common Rail Fuel System) Service Manual, Bulletin 4021271. Refer to Procedure 010-027 in Section 10.	Repair complete

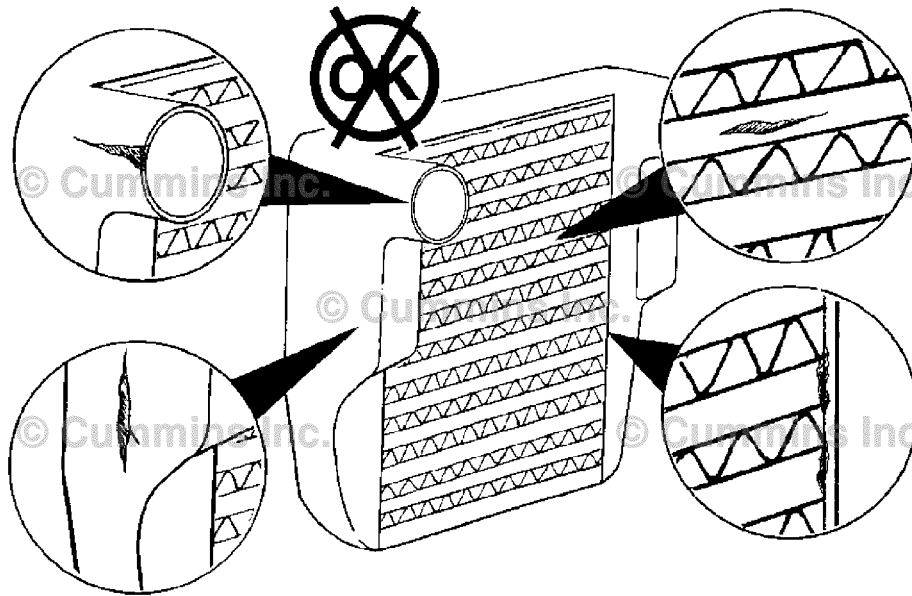

00d00112

STEP 6: EGR system checks.

STEP 6A: Check for air leaks in the EGR system.

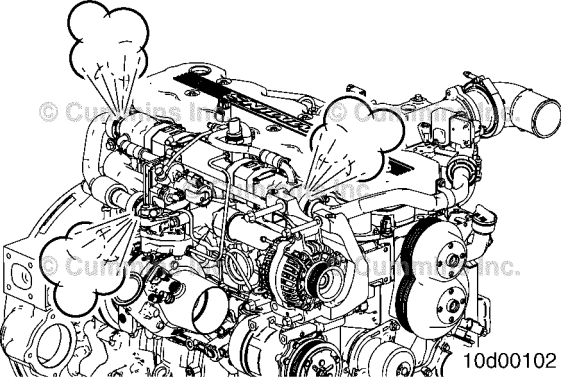
<p>Condition: N/A</p>		
Action	Specification/Repair	Next Step
<p>Check for air leaks in the EGR connection tubing and other connections.</p> <ul style="list-style-type: none"> • Check for EGR at the mounting flange for the differential pressure sensor. • Soot streaks can be noticeable where leaks are present. 	<p>Air leaks found in the EGR connection tubing? YES Repair: Repair any leaks in the EGR system.</p>	<p>Repair complete</p>
	<p>Air leaks found in the EGR connection tubing? NO</p>	<p>6B</p>
		

STEP 6B: Check the EGR temperature sensor accuracy.

<p>Condition:</p> <ul style="list-style-type: none"> • Turn keyswitch ON. • Connect INSITE™ electronic service tool. • The engine must be turned off long enough for engine coolant temperature to be equal to ambient air temperature. 		
Action	Specification/Repair	Next Step
<p>Monitor the following temperatures.</p> <p>Use INSITE™ electronic service tool to monitor temperature of the following:</p> <ul style="list-style-type: none"> • EGR temperature sensor • Engine coolant temperature sensor • Intake manifold air temperature sensor • Turbocharger compressor inlet air temperature sensor. 	<p>Are all temperature readings within 5.6°C [10°F] of each other?</p> <p>YES</p>	Step 6C
	<p>Are all temperature readings within 5.6°C [10°F] of each other?</p> <p>NO</p> <p>Repair:</p> <p>Check for a short from the signal pin of the temperature sensor in question to all other pins in the harness. Refer to Procedure 019-360 in Section 19. If no short is found, replace the temperature sensor that is reading higher or lower than the other sensors. See Section 19 for specifics on each temperature sensor.</p>	Repair complete

STEP 6C: Check differential pressure sensor for proper operation.

<p>Condition:</p> <ul style="list-style-type: none"> • Turn keyswitch ON. • Engine operating. • Connect INSITE™ electronic service tool. 		
Action	Specification/Repair	Next Step
<p>Operate the engine until the EGR valve opens.</p> <p>Use INSITE™ electronic service tool to monitor the EGR Differential Pressure and the EGR valve position (Percent Open).</p> <p>The EGR valve may not open until the engine has reached normal operating temperature.</p> <p>Once the engine has reached normal operating temperature, quick throttle snaps can help induce EGR valve movement.</p>	<p>Is the EGR differential pressure greater than 5 mm-Hg [0.2 in-Hg] when the EGR valve is open greater than 50 percent?</p> <p>YES</p>	6D
	<p>Is the EGR differential pressure greater than 5 mm-Hg [0.2 in-Hg] when the EGR valve is open greater than 50 percent?</p> <p>NO</p>	6F

STEP 6D: Check exhaust gas pressure sensor accuracy.

<p>Condition:</p> <ul style="list-style-type: none"> • Turn keyswitch ON. • Connect INSITE™ electronic service tool. • Engine OFF. 		
Action	Specification/Repair	Next Step
<p>Start the data monitor/logger.</p> <ul style="list-style-type: none"> • Use INSITE™ electronic service tool to compare the reading for exhaust pressure sensor and barometric pressure sensor. <p>If working on an engine not equipped with an exhaust pressure sensor, go to the next step.</p> <p>The exhaust pressure sensor is an absolute pressure sensor. This means that the sensor reads exhaust pressure plus barometric air pressure.</p>	<p>There is less than a 102 mm-Hg [4 in-Hg] difference between the exhaust pressure sensor reading and the barometric air pressure sensor reading?</p> <p>YES</p>	6E
	<p>There is less than a 102 mm-Hg [4 in-Hg] difference between the exhaust pressure sensor reading and the barometric air pressure sensor reading?</p> <p>NO</p> <p>Repair:</p> <p>Remove the exhaust pressure sensor, pedestal and exhaust pressure sensor tube. Use the following procedure in the ISBe, ISB, QSB (Common Rail Fuel System) Service Manual, Bulletin 4021271. Refer to Procedure 011-027 in Section 11. Check for condensation or foreign material build up. Clean or replace as necessary, any of the removed components.</p>	Repair Complete.

STEP 6E: Perform the INSITE™ electronic service tool EGR valve actuator test.

<p>Condition:</p> <ul style="list-style-type: none"> • Turn keyswitch ON. • Connect INSITE™ electronic service tool. 		
Action	Specification/Repair	Next Step
<p>ECM diagnostic tests.</p> <ul style="list-style-type: none"> • Use INSITE™ electronic service tool menu on the EGR Valve Actuator Test and follow the instructions on the screen. <p>Open and close the EGR valve actuator.</p> <p>When opened, the actuator position will be 100 percent open.</p> <p>When closed, the actuator position will be less than 10 percent closed.</p>	<p>Does the EGR Valve pass the INSITE™ electronic service tool EGR Valve Actuator Test?</p> <p>YES</p>	6F
	<p>Does the EGR Valve pass the INSITE™ electronic service tool EGR Valve Actuator Test?</p> <p>NO</p> <p>Repair:</p> <p>Replace the EGR valve. Use the following procedure in the ISBe, ISB, QSB (Common Rail Fuel System) Service Manual, Bulletin 4021271. Refer to Procedure 011-022 in Section 11.</p>	Repair Complete.

STEP 6F: Isolate EGR System.

<p>Condition:</p> <ul style="list-style-type: none"> • Turn keyswitch OFF. • Disconnect the EGR valve differential pressure sensor. 		
Action	Specification/Repair	Next Step
<p>Disconnect the EGR valve differential pressure sensor.</p> <p>Use the following procedure in the ISB (4 cylinder) and ISBe (4 and 6 cylinder) Electronic Control System Troubleshooting and Repair manual, Bulletin 3666477. Refer to Procedure 019-370 in Section 19.</p> <p>Operate the engine at which the Performance or Excessive Smoke (Black) complaint occurs.</p> <p>By disconnecting the EGR valve differential pressure sensor, the ECM will command the EGR valve to close. No engine derate will be commanded by the ECM. Fault Code 2274 will become active with the EGR valve differential pressure sensor disconnected.</p>	<p>Was the Performance or Excessive Smoke (Black) complaint corrected by disconnecting the EGR valve differential pressure sensor?</p> <p>YES</p>	6F-1
	<p>Was the Performance or Excessive Smoke (Black) complaint corrected by disconnecting the EGR valve differential pressure sensor?</p> <p>NO</p>	<p>Perform next troubleshooting procedure as outlined in Step 2.</p>

STEP 6F-1: Check the EGR System for Blockage

<p>Condition:</p> <ul style="list-style-type: none"> • Turn keyswitch OFF. • Remove the EGR valve differential pressure sensor. 		
Action	Specification/Repair	Next Step
<p>Remove the EGR valve differential pressure sensor and inspect the passages in the sensor and in the air intake connection for blockage or excessive carbon build up.</p> <p>Use the following procedure in the ISB (4 cylinder) and ISBe (4 and 6 cylinder) Electronic Control System Troubleshooting and Repair manual, Bulletin 3666477. Refer to Procedure 019-370 in Section 19. Use the following procedure in the ISBe, ISB, QSB (Common Rail Fuel System) Service Manual, Bulletin 4021271. Refer to Procedure 010-080 in Section 10.</p>	<p>Was blockage or excessive carbon build up found in the EGR valve differential pressure sensor and/or intake connection passages?</p> <p>YES</p> <p>Repair:</p> <p>Clean the passages in the sensor and in the air intake connection. If the blockage or carbon build up is to severe, replace the EGR valve differential pressure sensor and/or air intake connection. Use the following procedure in the ISB (4 cylinder) and ISBe (4 and 6 cylinder) Electronic Control System Troubleshooting and Repair manual, Bulletin 3666477. Refer to Procedure 019-370 in Section 19. Use the following procedure in the ISBe, ISB, QSB (Common Rail Fuel System) Service Manual, Bulletin 4021271. Refer to Procedure 010-080 in Section 10.</p>	<p>Repair Complete</p>
	<p>Was blockage or excessive carbon build up found in the EGR valve differential pressure sensor and/or intake connection passages?</p> <p>NO</p>	<p>6F-2</p>

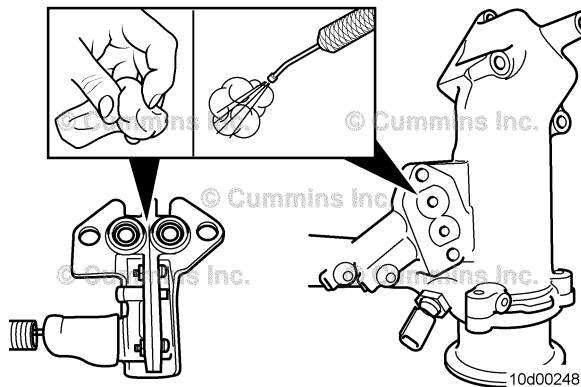

STEP 6F-2: Check the EGR system for correct or damaged components.

Condition:

- Turn keyswitch OFF.

Action	Specification/Repair	Next Step
<p>Check if the air intake connection is assembled properly and/or any components are damaged.</p> <p>1. Disconnect the EGR connection tubes from the air intake connection. Use the following procedure in the ISBe, ISB, QSB (Common Rail Fuel System) Service Manual, Bulletin 4021271. Refer to Procedure 011-025 in Section 11. Inspect the EGR inlet to the air intake connection to make sure the EGR flow measurement venture (1) is present and not damaged or blocked.</p> <p>2. Remove the two-piece air intake connection adapter. Use the following procedure in the ISBe, ISB, QSB (Common Rail Fuel System) Service Manual, Bulletin 4021271. Refer to Procedure 010-131 in Section 10. Verify the EGR mixer is installed and remove the EGR mixer. Use the following procedure in the ISBe, ISB, QSB (Common Rail Fuel System) Service Manual, Bulletin 4021271. Refer to Procedure 011-021 in Section 11. Inspect the EGR Mixer for damage or excessive carbon build up.</p> <p>If replacing the air intake connection on engines equipped with EGR, check to make sure the EGR flow measurement venture (1) is properly installed in the new air intake connection.</p>	<p>Was the air intake connection assembled properly with no damage to any components?</p> <p>YES</p> <p>Repair:</p> <p>Replace the EGR valve differential pressure sensor and air intake connection. Use the following procedure in the ISB (4 cylinder) and ISBe (4 and 6 cylinder) Electronic Control System Troubleshooting and Repair manual, Bulletin 3666477. Refer to Procedure 019-370 in Section 19. Use the following procedure in the ISBe, ISB, QSB (Common Rail Fuel System) Service Manual, Bulletin 4021271. Refer to Procedure 010-080 in Section 10.</p>	<p>Repair Complete</p>
<p>Was the air intake connection assembled properly with no damage to any components?</p> <p>NO</p> <p>Repair:</p> <p>Replace or clean the necessary component. Use the following procedure in the ISBe, ISB, QSB (Common Rail Fuel System) Service Manual, Bulletin 4021271. Refer to Procedure 011-021 in Section 11. If the EGR flow measurement venturi is damaged or missing, the entire air intake connection must be replaced as an assembly. The EGR flow measurement venturi can not be serviced separately. Use the following procedure in the ISBe, ISB, QSB (Common Rail Fuel System) Service Manual, Bulletin 4021271. Refer to Procedure 010-080 in Section 10.</p>	<p>Repair Complete</p>	

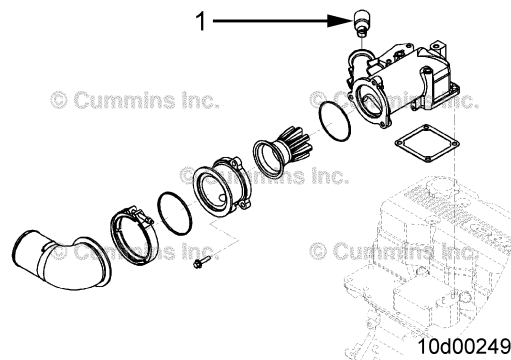

STEP 7: Verify electronic features are operating correctly.

STEP 7A: Verify accelerator (throttle) pedal travel.

<p>Condition:</p> <ul style="list-style-type: none"> • Turn keyswitch ON. • Connect INSITE™ electronic service tool. 		
Action	Specification/Repair	Next Step
<p>Use INSITE™ electronic service tool to monitor throttle position while fully depressing and releasing the accelerator (throttle) pedal.</p> <p>N/A</p>	<p>Does the throttle position read 0 percent when the accelerator (throttle) is released and 100 percent when the accelerator (throttle) is fully depressed?</p> <p>YES</p>	7B
	<p>Does the throttle position read 0 percent when the accelerator (throttle) is released and 100 percent when the accelerator (throttle) is fully depressed?</p> <p>NO</p> <p>Repair:</p> <p>Refer to the OEM service manual for accelerator (throttle) pedal troubleshooting.</p>	Repair complete

STEP 7B: Monitor vehicle speed.

<p>Condition:</p> <ul style="list-style-type: none"> • Turn keyswitch ON. • Connect INSITE™ electronic service tool. 		
Action	Specification/Repair	Next Step
<p>Monitor the vehicle speed.</p> <ul style="list-style-type: none"> • Use INSITE™ electronic service tool to monitor vehicle speed while the vehicle is not moving. 	<p>Does the vehicle speed read zero when the vehicle is not moving?</p> <p>YES</p>	7C
	<p>Does the vehicle speed read zero when the vehicle is not moving?</p> <p>NO</p> <p>Repair:</p> <p>Check the vehicle speed sensor and circuit for problems. Refer to the OEM service manual.</p>	Repair complete

STEP 7C: Verify the electronic feature settings are correct.

<p>Condition:</p> <ul style="list-style-type: none"> • Turn keyswitch ON. • Connect INSITE™ electronic service tool. 		
Action	Specification/Repair	Next Step
Use INSITE™ electronic service tool to verify the following adjustable parameters are correctly set: <ul style="list-style-type: none"> • Maximum vehicle speed • Powertrain protection • Rear axle ratio • Tailshaft teeth • Tire revolutions per mile • Gear-down protection • Cruise control droop settings • Cruise control maximum vehicle speed • Accelerator type • Road speed governor • Vehicle acceleration management • Transmission type. 	Are the electronic features set correctly? YES	7D
	Are the electronic features set correctly? NO Repair: Correct programmable features.	Repair complete

STEP 7D: Check the temperature sensor accuracy.

<p>Condition:</p> <ul style="list-style-type: none"> • Turn keyswitch ON. • Connect INSITE™ electronic service tool. • The engine must be turned off long enough for coolant temperature to be equal to ambient air temperature. 		
Action	Specification/Repair	Next Step
Use INSITE™ electronic service tool to monitor the following temperatures: <ul style="list-style-type: none"> • Engine coolant temperature sensor • Intake manifold air temperature sensor • If equipped, the turbocharger compressor inlet air temperature sensor • If equipped, the EGR temperature sensor. 	Are all temperature readings within 5.6°C or 10°F of each other? YES	Step 7E
	Are all temperature readings within 5.6°C or 10°F of each other? NO Repair: Check for a short from the SIGNAL pin of the temperature sensor in question to all other pins in the harness. Refer to Procedure 019-360 in Section 19. If no short is found, replace the temperature sensor that is reading higher or lower than the other sensors. See Section 19 for specifications on each temperature sensor.	Repair complete

STEP 7E: Check ambient air pressure sensor accuracy.

<p>Condition:</p> <ul style="list-style-type: none"> • Turn keyswitch ON. • Connect INSITE™ electronic service tool. 		
Action	Specification/Repair	Next Step
<p>Start INSITE™ electronic service tool data monitor/logger and compare the INSITE™ electronic service tool reading for barometric air pressure to the local barometric pressure. Refer to Procedure 018-028 in Section V.</p>	<p>INSITE™ electronic service tool reading is within 50.8 mm-Hg [2 in-Hg] of local barometric pressure? YES</p>	<p>Perform next troubleshooting procedure as outlined in Step 2.</p>
	<p>INSITE™ electronic service tool reading is within 50.8 mm-Hg [2 in-Hg] of local barometric pressure? NO Repair: Replace the barometric pressure sensor. Use the following procedure in the ISB (4 cylinder) and ISBe (4 and 6 cylinder) Electronic Control System Troubleshooting and Repair manual, Bulletin 3666477. Refer to Procedure 019-004 in Section 19.</p>	<p>Repair Complete</p>

STEP 8: Perform base engine mechanical checks.

STEP 8A: Verify the overhead adjustments are correct.

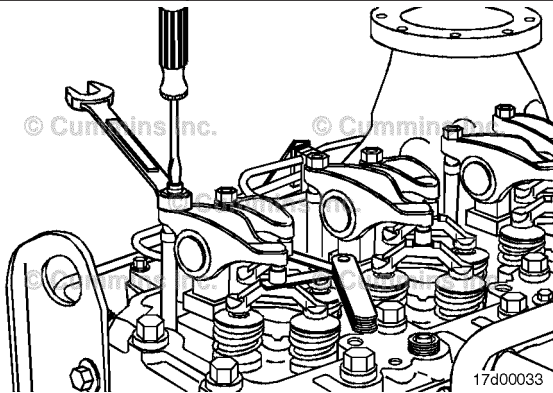
<p>Condition:</p> <ul style="list-style-type: none"> • Turn keyswitch OFF. • Remove valve cover. 		
Action	Specification/Repair	Next Step
<p>Measure the overhead settings.</p> <ul style="list-style-type: none"> • Use the following procedure in the ISBe, ISB, QSB (Common Rail Fuel System) Service Manual, Bulletin 4021271. Refer to Procedure 003-004 in Section 3. 	<p>Are the overhead settings within the reset limits?</p> <p>YES</p>	8B
	<p>Are the overhead settings within the reset limits?</p> <p>NO</p> <p>Repair:</p> <p>Adjust the overhead settings. Use the following procedure in the ISBe, ISB, QSB (Common Rail Fuel System) Service Manual, Bulletin 4021271. Refer to Procedure 003-004 in Section 3.</p>	Repair complete
		

STEP 8B: Check the exhaust restriction.

Condition:

- Turn keyswitch ON.
- Engine running at advertised horsepower and rpm.

Action	Specification/Repair	Next Step
Measure exhaust system back pressure. Measure the exhaust system back pressure by installing a pressure gage, Cummins® Part Number ST-1273, or equivalent, into the exhaust system immediately downstream of the turbocharger exhaust outlet. Maximum Exhaust Back Pressure = 10.2 kPa [1.5 PSI].	Is the exhaust back pressure greater than the specification? YES Repair: Correct the cause of high back pressure, look for collapsed or plugged exhaust pipes.	Repair complete
	Is the exhaust back pressure greater than the specification? NO	8C

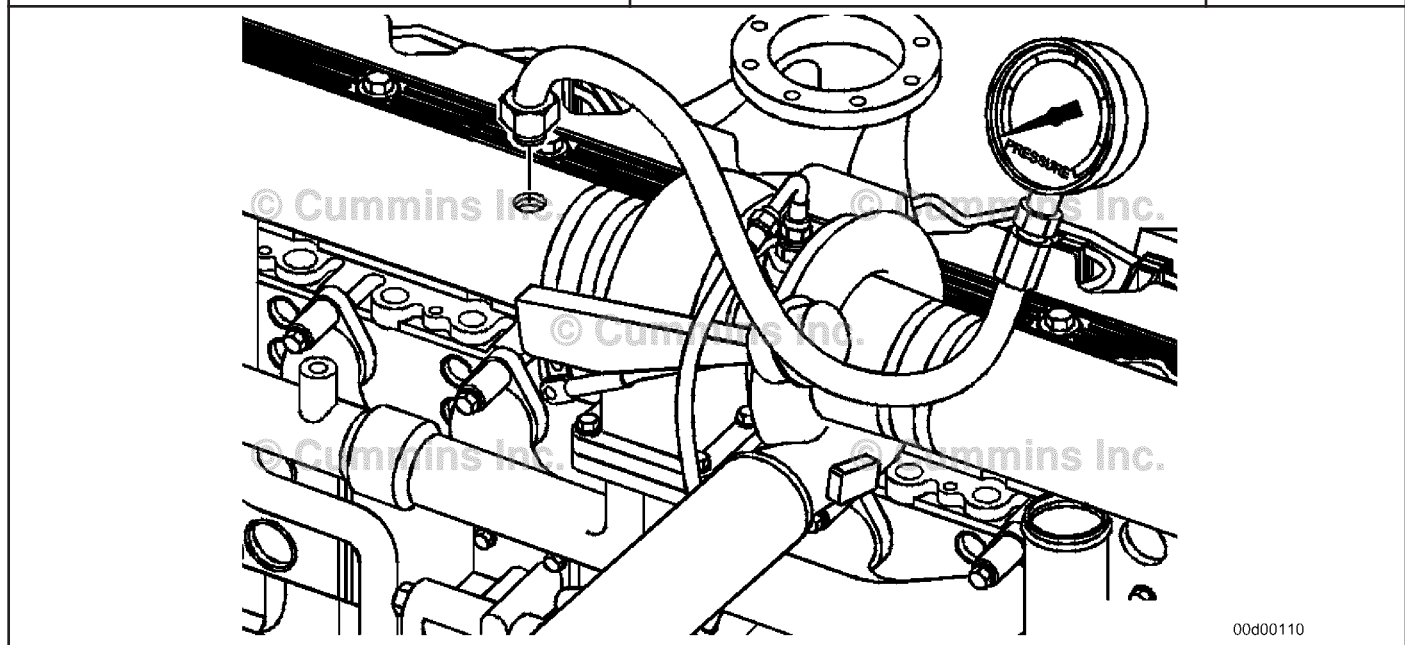

00d00110

STEP 8C: Verify the engine crankcase pressure (blowby) is within specification.

Condition:

- Turn keyswitch OFF.
- Connect appropriate service tools to measure blowby.

Action	Specification/Repair	Next Step
Measure engine crankcase pressure (blowby). Use the following procedure in the ISBe, ISB, QSB (Common Rail Fuel System) Service Manual, Bulletin 4021271. Refer to Procedure 014-010 in Section 14.	Is the engine crankcase pressure (blowby) less than specification? YES	8D
	Is the engine crankcase pressure (blowby) less than specification? NO Repair: Record the engine blowby pressure for later use.	Refer the Crankcase Gases (Blowby) Excessive troubleshooting symptom (TS) tree.

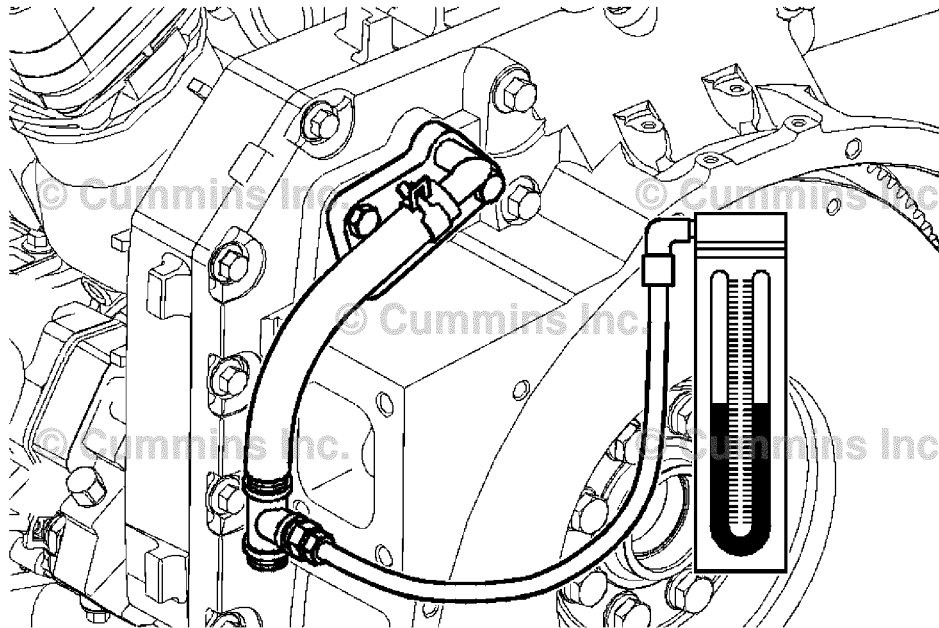

00d00111

STEP 8D: Check for internal engine damage.

<p>Condition:</p> <ul style="list-style-type: none"> • Turn keyswitch OFF. 		
Action	Specification/Repair	Next Step
<p>Remove the oil filter.</p> <p>Use the following procedure in the ISBe, ISB, QSB (Common Rail Fuel System) Service Manual, Bulletin 4021271. Refer to Procedure 007-013 in Section 7.</p> <p>Cut the oil filter open and inspect for debris and area of probable damage. Use the following procedure in the ISBe, ISB, QSB (Common Rail Fuel System) Service Manual, Bulletin 4021271. Refer to Procedure 007-083 in Section 7.</p>	<p>Did cutting the oil filter open reveal evidence of internal engine damage?</p> <p>YES</p> <p>Repair:</p> <p>Determine the area of probable damage and repair as necessary. Remove the lubricating oil pan and rocker lever cover, if necessary, to inspect for damage.</p> <ul style="list-style-type: none"> • Use the following procedure in the ISBe, ISB, QSB (Common Rail Fuel System) Service Manual, Bulletin 4021271. Refer to Procedure 007-025 in Section 7. • Use the following procedure in the ISBe, ISB, QSB (Common Rail Fuel System) Service Manual, Bulletin 4021271. Refer to Procedure 003-011 in Section 3. 	<p>Repair complete</p>
	<p>Did cutting the oil filter open reveal evidence of internal engine damage?</p> <p>NO</p>	<p>Perform next troubleshooting procedure as outlined in Step 2.</p>

STEP 9: Excessive vibration checks.

STEP 9A: Check engine idle speed.

<p>Condition:</p> <ul style="list-style-type: none"> • Turn keyswitch ON. • Connect INSITE™ electronic service tool. • INSITE™ electronic service tool monitor. 		
Action	Specification/Repair	Next Step
<p>Monitor the engine speed.</p> <ul style="list-style-type: none"> • Use INSITE™ electronic service tool to monitor engine speed while engine is idling. <p>See the engine dataplate for idle speed specifications.</p>	<p>Is the engine idle speed within specification?</p> <p>YES</p> <p>Repair:</p> <p>N/A</p>	<p>9B</p>
	<p>Is the engine idle speed within specification?</p> <p>NO</p> <p>Repair:</p> <p>Adjust or increase the engine idle speed.</p>	<p>Repair Complete</p>

STEP 9B: Check if the feature Fast Idle Warm Up is available and enabled.

Condition: <ul style="list-style-type: none"> • Turn keyswitch ON. • Connect INSITE™ electronic service tool. 		
Action	Specification/Repair	Next Step
Check the features and parameters with INSITE™ electronic service tool. Check if the feature Fast Idle Warm Up is available and enabled.	Is the feature Fast Idle Warm Up available and enabled? YES	9B-1
	Is the feature Fast Idle Warm Up available and enabled? NO	9C

STEP 9B-1: Monitor the Fast Idle Warm Up Status.

Condition: <ul style="list-style-type: none"> • Turn keyswitch ON. • Connect INSITE™ electronic service tool. • INSITE™ electronic service tool monitor. 		
Action	Specification/Repair	Next Step
Monitor the Fast Idle Warm Up INSITE™ electronic service tool status. N/A	Is the feature Fast Idle Warm Up becoming active? YES Repair: Adjust the fast idle warm up idle speed or check with the customer on disabling the feature. Disabling the fast idle warm up feature can affect warranty.	Repair Complete
	Is the feature Fast Idle Warm Up becoming active? NO	9C

STEP 9C: Check front engine driven accessory(s).

Condition: <ul style="list-style-type: none"> • Turn keyswitch OFF. • Isolate front engine driven accessory(s). 		
Action	Specification/Repair	Next Step
Isolate front engine driven accessory(s) one at a time, including: <ul style="list-style-type: none"> • Alternator(s) • Refrigerant compressor(s) • Fan hub(s) • Hydraulic/Power steering pump(s) • Water pump • Cooling fan • Crankshaft driven PTO accessories. 	Did isolating the front engine driven accessory(s) correct the vibration? YES Repair: Repair or replace the malfunctioning component.	Repair Complete.
	Did isolating the front engine driven accessory(s) correct the vibration? NO	9D

STEP 9D: Check the Vibration Damper/Crankshaft speed indicator ring.

Condition: <ul style="list-style-type: none"> • Turn keyswitch OFF. 		
Action	Specification/Repair	Next Step
Check the vibration damper/ crankshaft speed indicator ring for damage. For engines equipped with a rubber vibration damper, use the following procedure in the ISBe, ISB, QSB (Common Rail Fuel System) Service Manual, Bulletin 4021271. Refer to Procedure 001-051 in Section 1. For engines equipped with a viscous damper, use the following procedure in the ISBe, ISB, QSB (Common Rail Fuel System) Service Manual, Bulletin 4021271. Refer to Procedure 001-052 in Section 1. For engines equipped with a crankshaft speed indicator ring only , use the following procedure in the ISBe, ISB, QSB (Common Rail Fuel System) Service Manual, Bulletin 4021271. Refer to Procedure 001-071 in Section 1.	Is the vibration damper/crankshaft speed indicator ring damaged? YES Repair: Replace the damaged vibration damper/ crankshaft speed indicator ring.	Repair Complete.
	Is the vibration damper/crankshaft speed indicator ring damaged? NO	9E

STEP 9E: Check the Engine Support Brackets, Mounts and/or Isolators.

Condition: • Turn keyswitch OFF.		
Action	Specification/Repair	Next Step
Check the engine support brackets, mounts and/or isolators for damage. For front engine supports, use the following procedure in the ISBe, ISB, QSB (Common Rail Fuel System) Service Manual, Bulletin 4021271. Refer to Procedure 016-002 in Section 16. For rear engine supports, use the following procedure in the ISBe, ISB, QSB (Common Rail Fuel System) Service Manual, Bulletin 4021271. Refer to Procedure 016-003 in Section 16.	Are the engine support brackets, mounts and/or isolators damaged? YES Repair: Replace the damaged engine support brackets, mounts and/or isolators.	Repair Complete.
	Are the engine support brackets, mounts and/or isolators damaged? NO	9F

STEP 9F: Check engine gear driven accessory(s).

Condition: • Turn keyswitch OFF.		
Action	Specification/Repair	Next Step
Check if the engine has an engine gear driven/air compressor driven hydraulic pump? N/A	Does the engine have an engine gear driven/air compressor driven hydraulic pump? YES	9F-1
	Does the engine have an engine gear driven/air compressor driven hydraulic pump? NO	9F-2

STEP 9F-1: Isolate engine gear driven accessory(s).

Condition: • Turn keyswitch OFF. • Isolate/remove the gear/air compressor driven hydraulic pump.		
Action	Specification/Repair	Next Step
Isolate/remove the gear driven/air compressor driven hydraulic pump and operate the engine. For general hydraulic pump remove and install instructions, use the following procedure in the ISBe, ISB, QSB (Common Rail Fuel System) Service Manual, Bulletin 4021271. Refer to Procedure 009-016 in Section 9. Some engines require an accessory drive to drive the hydraulic pump. It may be necessary to isolate this as well. Use the following procedure in the ISBe, ISB, QSB (Common Rail Fuel System) Service Manual, Bulletin 4021271. Refer to Procedure 009-001 in Section 9.	Did isolating/removing engine gear driven/air compressor driven hydraulic pump correct the vibration? YES Repair: Repair or replace the malfunctioning component.	Repair Complete.
	Did isolating/removing engine gear driven/air compressor driven hydraulic pump correct the vibration? NO	9F-2

STEP 9F-2: Check if the engine is equipped with an air compressor.

Condition: <ul style="list-style-type: none"> • Turn keyswitch OFF. 		
Action	Specification/Repair	Next Step
Check if the engine is equipped with an engine gear driven air compressor. N/A	Is the engine is equipped with an engine gear driven air compressor? YES	9F-3
	Is the engine is equipped with an engine gear driven air compressor? NO	9G

STEP 9F-3: Unload the Air Compressor and Operate.

Condition: <ul style="list-style-type: none"> • Turn keyswitch OFF. • Unload the air compressor. 		
Action	Specification/Repair	Next Step
With the air compressor unloaded, operate the engine in the condition in which the vibration complaint occurs. The air compressor can be unloaded by: Disconnecting the air governor signal line and connecting regulated shop air, with a pressure gauge, to the air compressor governor air signal port. Typically 621 kPa (90 psi) of air pressure is the set point for unloading the air compressor. Refer to the OEM service manual. Disconnect the air compressor discharge line and air intake hose from the air compressor. On turbocharged air compressors, make sure to plug the air intake hose attached to the intake manifold.	Did unloading the air compressor significantly reduce or eliminate the vibration? YES	9F-4
	Did unloading the air compressor significantly reduce or eliminate the vibration? NO	Repair Complete.

STEP 9F-4: Check Air Compressor Timing.

<p>Condition:</p> <ul style="list-style-type: none"> • Turn keyswitch OFF. • Check the timing of the air compressor. 		
Action	Specification/Repair	Next Step
<p>Check that the air compressor is correctly timed to the engine.</p> <p>Use the following procedure in the ISBe, ISB, QSB (Common Rail Fuel System) Service Manual, Bulletin 4021271. Refer to Procedure 012-014 in Section 12.</p> <p>When troubleshooting a vibration issue in which it is suspected that the air compressor is the cause of the vibration, it may be necessary to isolate the air compressor from the engine.</p>	<p>Was the air compressor correctly timed to the engine?</p> <p>YES</p> <p>Repair:</p> <p>Replace the air compressor. Use the following procedure in the ISBe, ISB, QSB (Common Rail Fuel System) Service Manual, Bulletin 4021271. Refer to Procedure 012-014 in Section 12.</p>	<p>Repair Complete.</p>
	<p>Was the air compressor correctly timed to the engine?</p> <p>NO</p> <p>Repair:</p> <p>Correctly time the air compressor to the engine. Use the following procedure in the ISBe, ISB, QSB (Common Rail Fuel System) Service Manual, Bulletin 4021271. Refer to Procedure 012-014 in Section 12.</p>	<p>Repair Complete.</p>

STEP 9G: Check/Isolate engine driven components.

<p>Condition:</p> <ul style="list-style-type: none"> • Turn keyswitch OFF. • Isolate/remove any engine driven components. 		
Action	Specification/Repair	Next Step
<p>Isolate/remove any engine driven components and operate the engine.</p> <p>Engine driven components include:</p> <ul style="list-style-type: none"> • Transmissions (Torque converters/Clutches) • Hydraulic pumps • Direct drive shafts • For flywheels, use the following procedure in the ISBe, ISB, QSB (Common Rail Fuel System) Service Manual, Bulletin 4021271. Refer to Procedure 016-005 in Section 16. • For flexplates, use the following procedure in the ISBe, ISB, QSB (Common Rail Fuel System) Service Manual, Bulletin 4021271. Refer to Procedure 016-004 in Section 16. 	<p>Did isolating/removing any engine driven component correct the vibration?</p> <p>YES</p> <p>Repair:</p> <p>Replace the malfunctioning component. Refer to the OEM service manual.</p>	<p>Repair Complete.</p>
	<p>Did isolating/removing any engine driven component correct the vibration?</p> <p>NO</p>	<p>9H</p>

STEP 9H: Check the Flywheel Housing Alignment.

<p>Condition:</p> <ul style="list-style-type: none"> • Turn keyswitch OFF. • Engine driven components removed. 		
Action	Specification/Repair	Next Step
<p>Measure the flywheel housing bore and face runout.</p> <p>Use the following procedure in the ISBe, ISB, QSB (Common Rail Fuel System) Service Manual, Bulletin 4021271. Refer to Procedure 016-006 in Section 16.</p>	<p>Is the flywheel housing bore and face runout within specification?</p> <p>YES</p>	<p>8A</p>
	<p>Is the flywheel housing bore and face runout within specification?</p> <p>NO</p> <p>Repair:</p> <p>For flywheel housing repair options, use the following procedure in the ISBe, ISB, QSB (Common Rail Fuel System) Service Manual, Bulletin 4021271. Refer to Procedure 016-006 in Section 16.</p>	<p>Repair Complete.</p>

Vibration Excessive

This troubleshooting procedure should be followed for the following symptoms:

- Vibration excessive
- Cab noise due to vibration

How to Use This Troubleshooting Procedure:

This symptom tree can be used to troubleshoot all vibration-based symptoms listed above. Start by performing Step 1 troubleshooting. Step 2 will ask a series of questions and will provide a list of troubleshooting steps to perform, depending on the symptoms. Perform the list of troubleshooting steps in the sequence shown in the Specifications/Repair section of the tree.

Shop Talk:

Vibration Troubleshooting Documentation Information Questions

- 1) What is the original equipment manufacturer (OEM) make/model?
- 2) What are the mileage/hours?
- 3) Has there been any recent repair and/or maintenance history?
 - Any engine/clutch/transmission rebuild, removal, and installation?
 - History of repeatedly broken brackets and/or capscrews (alternator, fan, exhaust, etc.)?
 - Structural modifications to the vehicle from OEM built?
- 4) Description of vibration?
 - What is shaking (mirror, seat, steering wheel, cab/dash, etc.)?
 - Is there excessive noise in the cab during the vibration?
- 5) What are the conditions when the complaint occurs?
 - Power take-off (PTO)?
 - Power output (hard pull, during lug down, etc.)?
 - During acceleration and/or deceleration?
 - At idle?
 - With or without a trailer?
 - Does vibration increase with engine speed?
 - Does vibration increase with road speed?
 - Is the vibration at a certain engine revolutions per minute (rpm)?
- 6) Has the vibration been present since new? (From new, recent repair, modification to equipment)
- 7) Can the vibration be easily duplicated?
- 8) Do you have another piece of equipment with the same specification which exhibits the same complaint? (If yes, get the engine serial number (ESN) and possibly test the vehicle)
- 9) Are you the **only** operator of the equipment? (If no, are the symptoms noticed by other operators?)

General Information

Vibration complaints can be very difficult to troubleshoot and understand the root cause. This troubleshooting document was designed to help guide you through the logical steps of identifying the source. Vibration acceptance is very subjective; what is objectionable to one person can possibly be acceptable to another.

Vibration complaints can be caused by many parts in the system (system includes the engine, driven component, mounts, and equipment). The cause can be transmitted or generated from a remote point that is **not** readily apparent.

Cummins Inc. experience has shown that the engine is rarely the cause of an operator complaint. The majority of the time, it is the engine mounts or design of the various components on the equipment. The engine is **only** at fault if there is a misfire or an engine component that is out of balance.

Vibration complaints that occur **only** at idle speed are most likely caused by the engine mounts. If the engine mount natural frequency is close to the engine firing frequency, the engine will cause the mounts to amplify the normal vibration on an engine idling and cause the adjacent components to vibrate excessively.

Natural Frequency

- Natural frequency, as the name implies, is the frequency at which an object wants to naturally vibrate. The frequency is primarily dependent on mass and elasticity.

Types of Vibration

1) Linear

a) Rotating components

b) Torque reaction

- Caused by unbalanced rotating components and cylinder firing impulses.
- Can be felt and observed visibly.
- When excessive, can cause operator discomfort and destruction of components.

2) Torsional - twisting stresses

- Cyclic speeding and slowing of rotating components.
- Controlled by flywheel mass and vibration damper.
- Can **NOT** be felt by the operator.
- Can damage gears and splines.

3) Resonant - component excited at natural frequency

- Is actually linear vibration.
- Resonant vibration occurs when a system or component is excited by linear vibration at its natural frequency.
- Vibration will increase in amplitude as the system's natural frequency is approached. Amplitude will decrease as the exciting forces (engine firing frequency) increase in frequency beyond the system's natural frequency.
- Resonant vibration can be many times larger in amplitude than the exciting force.
- Vibration **must** be controlled by design of mounts (engine and cab) and components.

Engine and Cab Mounts

- The mounts **must** be designed to isolate or reduce the transmission of engine and equipment component vibrations.
- For maximum isolation, it is desired that the natural frequency of the mount be as low as possible.
- Good engine mounts will reduce the amount of engine vibration transmitted to the chassis frame by at least 50 percent at idle.
- Hard engine mounts will give little or no isolation, and can actually magnify the vibration transmitted to the chassis.
- Stiffness (durometer) and size of the isolator, along with the weight of the engine or component applied, are the determining factors when designing a mounting system. An isolator that is correct for one engine, can possibly **not** be right for another. Likewise, because of weight differential, a particular isolator designed for the rear of an engine, probably will **not** be ideal for the front.

TROUBLESHOOTING SUMMARY

STEPS	SPECIFICATIONS	SRT CODE
STEP 1: Perform the basic troubleshooting procedures.		
STEP 1A: Document the information questions in the Shop Talk section of this tree.	Documentation completed?	
STEP 1B: Duplicate the complaint based on the customer description.	Customer's complaint be duplicated?	
STEP 1C: Check for active fault codes or high counts of inactive fault codes.	Active fault codes or high counts of inactive fault codes?	
STEP 1D: Perform the basic troubleshooting checks.	All steps verified to be correct?	
STEP 1E: Determine if the engine is running rough.	Engine running rough?	
STEP 1F: Perform a visual inspection of the engine mounts (without removal).	Visible engine mount damage?	
STEP 1G: Check for an engine mounted component contacting the frame or body.	Engine mounted components touching the frame or body?	
STEP 1H: Marine application.	Engine installed in a marine application?	
STEP 1I: Do an engine rpm sweep.	Vibration present stationary below 1050 rpm?	
STEP 1J: Do an engine rpm sweep.	Vibration present stationary above 1050 rpm?	
STEP 1K: Check the vibration engine speed range.	Vibration speed range greater than 300 to 400 rpm?	
STEP 2: Perform low rpm checks.		
STEP 2A: Check that the accessory load is not excessive for the idle speed setting.	All steps verified to be correct?	
STEP 2B: Check that the Fast Idle Warm-Up feature is activating (if applicable).	Fast Idle Warm-Up feature inactive?	
STEP 2C: Check that the Alternator Failure Warning feature is activating (if applicable).	Alternator Failure Warning feature inactive?	
STEP 2D: Check for malfunctioning belt driven accessories.	Vibration go away with the drive belts removed?	
STEP 2E: Check for equipment structural modifications.	Any structural modifications to the equipment present?	
STEP 2F: Check the engine mount transmissibility for the rear mount.	Vibration go away during the test condition?	
STEP 2F-1: Check the engine mount transmissibility for all mounts.	Vibration go away during the test condition?	

STEP 2G: Inspect the engine mounts.

All steps verified to be correct?

STEP 2H: Complaint since new.

Problem been occurring since the equipment was new?

STEP 3: Perform higher rpm checks.

STEP 3A: Inspect the engine mounts.

All steps verified to be correct?

STEP 3B: Check for malfunctioning belt driven accessories.

Vibration go away with the drive belts removed?

STEP 3C: Check for a damaged vibration damper.

Vibration damper damaged or out of specification?

STEP 3D: Check the air compressor timing.

Air compressor timing correct?

STEP 3E: Check the overhead adjustments.

Overhead adjustments correct?

STEP 3F: Check for malfunctioning gear driven components.

Vibration go away?

STEP 3G: Check for a damaged PTO.

Vibration go away?

STEP 3H: Check for a malfunctioning engine internal balancer assembly (4 cylinder B-Series only).

Internal balancer meet specification?

STEP 3I: Check the clutch or torque converter for vibration.

Engaging and disengaging the clutch affect the vibration?

STEP 3J: Check for a loose or damaged flywheel or flex plate.

Flywheel meet specifications?

STEP 3K: Check the flywheel housing for correct alignment.

Flywheel housing meet specifications?

STEP 3L: Check to see if the crankshaft has been balanced.

Crankshaft balanced?

STEP 3M: Check for internal engine damage.

Internal engine damage?

STEP 4: Operate the mobile equipment.

STEP 4A: Perform a diagnostic road test.

Vibration present during a diagnostic road test?

STEP 4A-1: Perform a diagnostic road test.

Vibration present with the transmission in neutral, under the road speed conditions, where the vibration was duplicated driving?

STEP 4B: Inspect the engine mounts.

All steps verified to be correct?

STEP 4C: Check for drive train components that are worn, unbalanced, malfunctioning, or are not correct.

All steps verified to be correct?

STEP 5: Marine applications.

STEP 5A: Check the gear ratio and propeller configuration.

Gear ratio and the propeller incorrectly matched to the engine power?

STEP 5B: Check for the correct engine mounting isolators and for

Engine mount isolators correct and installed correctly?

	proper installation requirements.	
STEP 5C:	Check for damaged engine mounts and isolators.	Engine mounts and isolators in good condition?
STEP 5D:	Check the exhaust system.	Exhaust system deficient?
STEP 5E:	Check the engine driven accessories.	Engine driven accessory malfunctioning?
STEP 5F:	Check the shaft coupling to gear coupling alignment.	Shaft coupling to gear coupling misaligned?
STEP 5G:	Check the propeller shaft for proper installation.	Propeller shaft installed correctly?
STEP 5H:	Check the propeller shaft for straightness.	Propeller shaft straightness within the OEM specification?
STEP 5I:	Isolate the engine.	Engine vibration persist?
STEP 5J:	Check for strut/cutlass bearing misalignment.	Strut/cutlass bearing misaligned or strut mounting not secure?
STEP 5K:	Check the propeller.	Propeller out of balance or not fitted properly to the shaft?
STEP 5L:	Check the V-angle on the V-strut.	V-angle on the V-strut match the angle of the blade on the prop?
STEP 5M:	Check the propeller tunnels.	Entry and exit of the propeller tunnel match with the propeller blades?
STEP 5N:	Check the engine to transmission torsional coupling.	Torsional coupling incorrect or worn?
STEP 5O:	Check the rudder.	Rudder have excessive play in the rudder post?
STEP 5P:	Check the engine flywheel housing to cylinder block alignment.	Flywheel housing alignment incorrect?

TROUBLESHOOTING STEP

STEP 1: Perform the basic troubleshooting procedures.
STEP 1A: Document the information questions in the Shop Talk section of this tree.

Condition: • None		
Action	Specification/Repair	Next Step
Perform the basic troubleshooting questionnaire. Complete the vibration troubleshooting documentation information questions contained in the Shop Talk section of this procedure.	Documentation completed? YES	1B
	Documentation completed? NO Repair: Complete the documentation.	1A

STEP 1B: Duplicate the complaint based on the customer description.

Condition: • None.		
Action	Specification/Repair	Next Step
Operate the equipment based on the description from the customer to duplicate the complaint. N/A	Customer's complaint be duplicated? YES	1C
	Customer's complaint be duplicated? NO	Repair complete

STEP 1C: Check for active fault codes or high counts of inactive fault codes.

Condition: • Turn keyswitch ON. • Connect INSITE™ electronic service tool.		
Action	Specification/Repair	Next Step
Check the fault codes. • Use INSITE™ electronic service tool to read the fault codes.	Active fault codes or high counts of inactive fault codes? YES Repair: See the corresponding Electronic Control System Troubleshooting and Repair manual for the engine being serviced.	Repair complete
	Active fault codes or high counts of inactive fault codes? NO	1D

STEP 1D: Perform the basic troubleshooting checks.

Condition: • As required.		
Action	Specification/Repair	Next Step
Check or verify the following items before continuing. • Battery voltage is low (engine running) • Lubricating oil level is above specification • External fuel leak • Engine idle speed is set too low • Engine idle speed is set too high • Throttle lever or pedal, return spring, or air throttle damaged or improperly adjusted (use INSITE™ electronic service tool for electronic engines) • Air in the fuel • Fuel pressure • Inlet restriction.	All steps verified to be correct? YES	1E
	All steps verified to be correct? NO	Repair complete

STEP 1E: Determine if the engine is running rough.

<p>Condition:</p> <ul style="list-style-type: none"> • Operate engine at idle speed (less than 900 rpm). • Turn accessories OFF(air conditioning, fan, PTO). • Operate engine at operating temperature (greater than 170°C [70°F]). 		
Action	Specification/Repair	Next Step
<p>Determine if the engine is running rough at engine idle.</p> <p>Refer to the Engine Runs Rough troubleshooting symptom tree in Section TS or the Engine Performance Troubleshooting Tree in Section TT.</p>	<p>Engine running rough?</p> <p>YES</p> <p>Repair:</p> <p>Refer to the Engine Runs Rough troubleshooting symptom tree in Section TS or the Engine Performance Troubleshooting Tree in Section TT.</p>	<p>Complete Engine Runs Rough troubleshooting tree</p>
	<p>Engine running rough?</p> <p>NO</p>	<p>1F</p>

STEP 1F: Perform a visual inspection of the engine mounts (without removal).

<p>Condition:</p> <ul style="list-style-type: none"> • Do not operate engine. • Install engine mounts. 		
Action	Specification/Repair	Next Step
<p>Perform a visual inspection of the engine mounts.</p> <p>Look for obvious damage or something shorting against the mounts, preventing isolation.</p> <p>A more detail inspection will be carried out later in the procedure.</p>	<p>Visible engine mount damage?</p> <p>YES</p> <p>Repair:</p> <p>Repair or replace the engine mounts. Refer to Procedure 016-010 in Section 16.</p>	<p>Repair complete</p>
	<p>Visible engine mount damage?</p> <p>NO</p>	<p>1G</p>

STEP 1G: Check for an engine mounted component contacting the frame or body.

Condition: <ul style="list-style-type: none"> Do not operate engine. Install engine moun. 		
Action	Specification/Repair	Next Step
Check for an engine mounted component touching the frame or body. Inspect the engine and engine mounted components to make sure none of them are touching the frame and/or body. Including but not limited to the following: <ul style="list-style-type: none"> Clamps Mounting hardware Exhaust system Air intake piping Cooling package support Etc. 	Engine mounted components touching the frame or body? YES Repair: Correct the mounting of the engine mounted component.	Repair complete
	Engine mounted components touching the frame or body? NO	1H

STEP 1H: Marine application.

Condition: None		
Action	Specification/Repair	Next Step
Engine in a marine application? N/A	Engine installed in a marine application? YES	5A
	Engine installed in a marine application? NO	1I

STEP 1I: Do an engine rpm sweep.

Condition: <ul style="list-style-type: none"> Operate engine Connect INSITE™ electronic service tool. Make sure of 0 vehicle speed. 		
Action	Specification/Repair	Next Step
Perform a slow (at 100 rpm per second) rpm sweep and observe where the vibration occurs. Record the engine speed at which any usual vibration or vibration related noise occurs (mirrors, panels, doors, seat, etc.). Record any speed points or ranges with excessive vibration. If a resonance is passed through quickly in getting up to the operating speed range and doesn't exist in the idle speed or peak operating range, it represents no major problem.	Vibration present stationary below 1050 rpm? YES	2A
	Vibration present stationary below 1050 rpm? NO	1J

STEP 1J: Do an engine rpm sweep.

<p>Condition:</p> <ul style="list-style-type: none"> • Operate engine. • Connect INSITE™ electronic service tool. • 0 vehicle speed. 		
Action	Specification/Repair	Next Step
<p>Perform a slow (at 100 rpm per second) rpm sweep and observe where the vibration occurs.</p> <p>Does the vibration increase progressively from idle to maximum speed? If so, rotating or reciprocating unbalance is the source. This can be caused by any rotating components or engine mount isolation.</p>	<p>Vibration present stationary above 1050 rpm?</p> <p>YES</p>	1K
	<p>Vibration present stationary above 1050 rpm?</p> <p>NO</p>	4A

STEP 1K: Check the vibration engine speed range.

<p>Condition:</p> <ul style="list-style-type: none"> • Operate engine • Connect INSITE™ electronic service tool. • Make sure of 0 vehicle speed. 		
Action	Specification/Repair	Next Step
<p>Perform a slow (at 100 rpm per second) rpm sweep and observe where the vibration occurs.</p> <p>This step is to identify if the vibration progressively increases with engine speed or if it starts and stops within a slow engine rpm band. If the vibration progressively increases with engine speed and has a peak band greater than 300 rpm, this can indicate a rotating component that is out of balance.</p> <p>If the vibration peak is in a tight band of approximately 300 to 400 rpm or less, this indicates that a structural component of the engine or equipment is going into resonance because its natural frequency is close to or the same as the engine firing frequency.</p>	<p>Vibration speed range greater than 300 to 400 rpm?</p> <p>YES</p>	3A
	<p>Vibration speed range greater than 300 to 400 rpm?</p> <p>NO</p>	2A

STEP 2: Perform low rpm checks.

STEP 2A: Check that the accessory load is not excessive for the idle speed setting.

<p>Condition:</p> <ul style="list-style-type: none"> Operate engine at idle speed (less than 900 rpm). Turn accessories off (air conditioning, fan, and PTO). Engine at operating temperature (greater than 77°C [170°F]). 		
Action	Specification/Repair	Next Step
Disable all engine driven accessories and PTOs to make sure they are not applying excessive load to the engine. N/A	All steps verified to be correct? YES	2B
	All steps verified to be correct? NO Repair: Repair as required.	Repair complete

STEP 2B: Check that the Fast Idle Warm-Up feature is activating, if applicable.

<p>Condition:</p> <ul style="list-style-type: none"> Turn keyswitch ON. Connect INSITE™ electronic service tool. 		
Action	Specification/Repair	Next Step
Check the Fast Idle Warm-Up status. Use INSITE™ electronic service tool Data Monitor/Logger to check the status of the Fast Idle Warm-Up feature.	Fast Idle Warm-Up feature inactive? YES	2C
	Fast Idle Warm-Up feature inactive? NO Repair: Disable the Fast Idle Warm-Up feature and retest for the customer's complaint.	Repair complete

STEP 2C: Check that the Alternator Failure Warning feature is activating, if applicable.

<p>Condition:</p> <ul style="list-style-type: none"> Turn keyswitch ON. Connect INSITE™ electronic service tool. 		
Action	Specification/Repair	Next Step
Check to see if the Alternator Failure Warning feature is active. Use INSITE™ electronic service tool Data Monitor/Logger to check that the Alternator Failure Warning feature is active.	Alternator Failure Warning feature inactive? YES	2D
	Alternator Failure Warning feature inactive? NO Repair: Disable the Alternator Failure Warning feature and retest for the customer's complaint.	Repair complete

STEP 2D: Check for malfunctioning belt driven accessories.

Condition: <ul style="list-style-type: none"> Remove drive belt(s). 		
Action	Specification/Repair	Next Step
Remove the drive belt(s) and operate the engine under the conditions where the vibration occurs. Caution: For engines with a belt driven water pump, do not allow the engine to overheat during the test. Engine damage will occur.	Vibration go away with the drive belts removed? YES Repair: Repair or replace the malfunctioning belt driven component.	Repair complete
	Vibration go away with the drive belts removed? NO	2E

STEP 2E: Check for equipment structural modifications.

Condition: <ul style="list-style-type: none"> Inspect. 		
Action	Specification/Repair	Next Step
Check for any structural modifications to the equipment. Check for any structural modifications to the equipment in the engine area that were completed by the OEM after equipment manufacture. <ul style="list-style-type: none"> Snow plows, frame rail extensions, front bumpers, etc. Structural modifications can change the natural frequency of the frame and engine mounting system, which can result in a vibration complaint.	Any structural modifications to the equipment present? YES Repair: Contact the equipment manufacturer. If possible, remove or isolate the structural modification.	Repair complete
	Any structural modifications to the equipment present? NO	2F

STEP 2F: Check the engine mount transmissibility of the rear mount.

Condition: <ul style="list-style-type: none"> Loosen the front engine mount capscrews. Operate engine at the documented rpm where the complaint occurs. 		
Action	Specification/Repair	Next Step
Check the engine mounts. This step is checking to see if the engine mounts are amplifying the firing frequency of the engine, since the vibration only occurs in a low engine rpm range. <ul style="list-style-type: none"> Loosen only the isolator capscrews for the front engine mount(s) and run the engine at idle. 	Vibration go away during the test condition? YES	2G
	Vibration go away during the test condition? NO	2F-1

STEP 2F-1: Check the engine mount transmissibility for all mounts.

<p>Condition:</p> <ul style="list-style-type: none"> Loosen all engine mount capscrews. Operate engine at the documented rpm where the complaint occurs. 		
Action	Specification/Repair	Next Step
<p>Check the engine mounts.</p> <p>This step is checking to see if the engine mounts are amplifying the firing frequency of the engine, since the vibration only occurs in a low engine rpm range.</p> <ul style="list-style-type: none"> Loosen the isolator capscrews for all of the engine mounts and run the engine at idle. 	<p>Vibration go away during the test condition?</p> <p>YES</p>	2G
	<p>Vibration go away during the test condition?</p> <p>NO</p>	2G

STEP 2G: Inspect the engine mounts.

<p>Condition:</p> <ul style="list-style-type: none"> Do not operate engine. Remove engine mount isolators. 		
Action	Specification/Repair	Next Step
<p>This step is a detailed inspection of the engine mount brackets, isolators, and mounting hardware.</p> <ul style="list-style-type: none"> Check the engine mount isolators for installation damage. Check the alignment of the engine mount brackets. Check for premature wear on the engine mount isolators and mounting hardware. 	<p>All steps verified to be correct?</p> <p>YES</p>	2H
	<p>All steps verified to be correct?</p> <p>NO</p> <p>Repair: Repair or replace the damaged components.</p>	Repair complete

STEP 2H: Complaint since new.

<p>Condition:</p> <ul style="list-style-type: none"> Record the odometer/hour meter. Review the troubleshooting documentation information questions. 		
Action	Specification/Repair	Next Step
<p>Check the equipment.</p> <p>Check the equipment mileage/hours and compare to the vibration customer interview form completed in Step 1A.</p> <ul style="list-style-type: none"> Low mileage is an indication that the complaint has been present since the equipment was new. Complaints on new equipment are typically due to a manufacturing defect in the system or an inadequate engine mounting design. 	<p>Problem been occurring since the equipment was new?</p> <p>YES</p> <p>Repair: The engine mounts are not the right specification for the application, or a structural resonance exists.</p>	Contact a Cummins® Technical Support Specialist or the OEM
	<p>Problem been occurring since the equipment was new?</p> <p>NO</p> <p>Repair: Recheck for shorts, a rough running engine, or malfunctioning engine mounts.</p>	Contact a Cummins® Technical Support Specialist or the OEM

STEP 3: Perform higher rpm checks.

STEP 3A: Inspect the engine mounts.

<p>Condition:</p> <ul style="list-style-type: none"> • Do not operate engine. • Remove the engine mount isolators. 		
Action	Specification/Repair	Next Step
<p>Inspect the engine mount brackets, isolators, and mounting hardware.</p> <ul style="list-style-type: none"> • Check the engine mount isolators for installation damage. • Check the alignment of the engine mount brackets. • Check for premature wear on the engine mount isolators and mounting hardware. 	<p>All steps verified to be correct? YES</p>	3B
	<p>All steps verified to be correct? NO Repair: Repair or replace the malfunctioning components. Refer to Procedure 016-010 in Section 16.</p>	Repair complete

STEP 3B: Check for malfunctioning belt driven accessories.

<p>Condition:</p> <ul style="list-style-type: none"> • Remove the drive belts. 		
Action	Specification/Repair	Next Step
<p>Check the belt driven accessories. Remove the drive belts and operate the engine under the conditions where the vibration occurs.</p> <p>Caution: For engines with a belt driven water pump, do not allow the engine to overheat during the test. Engine damage will occur.</p>	<p>Vibration go away with the drive belts removed? YES Repair: Repair or replace the malfunctioning belt driven accessory.</p>	Repair complete
	<p>Vibration go away with the drive belts removed? NO</p>	3C

STEP 3C: Check for a damaged vibration damper.

Condition: <ul style="list-style-type: none"> Do not operate engine. 		
Action	Specification/Repair	Next Step
Remove and visually inspect the vibration damper. Use Procedure 001-052 in Section 1 in the appropriate service manual for vibration damper inspection specifications.	Vibration damper damaged or out of specification? YES Repair: Replace the vibration damper. Reference the appropriate service manual.	Repair complete
	Vibration damper damaged or out of specification? NO	3D

STEP 3D: Check the air compressor timing.

Condition: <ul style="list-style-type: none"> Do not operate engine. Remove air compressor. 		
Action	Specification/Repair	Next Step
Check the air compressor timing. Reference Procedure 012-014 in Section 12 of the appropriate service manual.	Air compressor timing correct? YES	3E
	Air compressor timing correct? NO Repair: Correct the air compressor timing and retest for the vibration complaint. Reference Procedure 012-014 in Section 12 of the appropriate service manual.	Repair complete

STEP 3E: Check the overhead adjustments.

Condition: <ul style="list-style-type: none"> Do not operate engine. Remove rocker lever cover. 		
Action	Specification/Repair	Next Step
Measure and adjust the overhead settings. <ul style="list-style-type: none"> Check the overhead components for damage. Reference Procedure 003-004 in Section 3 of the appropriate service manual.	Overhead adjustments correct? YES	3F
	Overhead adjustments correct? NO Repair: Repair or adjust the overhead. Reference Procedure 003-004 in Section 3 of the appropriate service manual.	Repair complete

STEP 3F: Check for malfunctioning gear driven components.

Condition: None.		
Action	Specification/Repair	Next Step
Check the hydraulic pump and air compressor. If possible, isolate any gear-driven accessories and check for vibration.	Vibration go away? YES Repair: Repair or replace the gear driven components.	Repair complete
	Vibration go away? NO	3G

STEP 3G: Check for a damaged PTO.

Condition: • Disconnect the PTO.		
Action	Specification/Repair	Next Step
Check the PTO for damage and correct installation. Refer to the OEM service manual.	Vibration go away? YES Repair: Repair the PTO. Refer to the OEM service manual.	Repair complete
	Vibration go away? NO	3H

STEP 3H: Check for a malfunctioning engine internal balancer assembly (4 cylinder B-Series only).

Condition: • None.		
Action	Specification/Repair	Next Step
Inspect the engine internal balancer assembly. Reference Procedure 001-004 in Section 1 of the appropriate service manual. This applies to 4 cylinder B-Series engines only .	Internal balancer meet specification? YES	3I
	Internal balancer meet specification? NO Repair: Repair the internal balancer. Reference Procedure 001-004 in Section 1 of the appropriate service manual.	Repair complete

STEP 3I: Check the clutch or torque converter for vibration.

Condition: <ul style="list-style-type: none"> Operate engine. 		
Action	Specification/Repair	Next Step
With engine running in the operating condition of the vibration, disengage and engage the clutch several times. If there is a significant vibration reduction, clutch plate(s) balance is the source.	Engaging and disengaging the clutch affect the vibration? YES Repair: Repair or replace the clutch. Refer to the OEM service manual.	Repair complete
	Engaging and disengaging the clutch affect the vibration? NO	3J

STEP 3J: Check for a loose or damaged flywheel or flex plate.

Condition: <ul style="list-style-type: none"> Remove transmission. 		
Action	Specification/Repair	Next Step
Check the flywheel. <ul style="list-style-type: none"> Check the flywheel bore and face run out. Check the flywheel for damage. Reference Procedure 016-005 in Section 16 of the appropriate service manual.	Flywheel meet specifications? YES	3K
	Flywheel meet specifications? NO Repair: Repair or replace the flywheel or flexplate. Reference Procedure 016-005 in Section 16 of the appropriate service manual.	Repair complete

STEP 3K: Check the flywheel housing for correct alignment.

Condition: <ul style="list-style-type: none"> Remove transmission. Remove flywheel/flexplate. 		
Action	Specification/Repair	Next Step
Check the flywheel housing bore and face alignment. Reference Procedure 016-006 in Section 16 of the appropriate service manual.	Flywheel housing meet specifications? YES	3L
	Flywheel housing meet specifications? NO Repair: Repair or replace the flywheel housing. Reference Procedure 016-006 in Section 16 of the appropriate service manual.	Repair complete

STEP 3L: Check to see if the crankshaft has been balanced.

<p>Condition:</p> <ul style="list-style-type: none"> • Do not operate engine. • Remove lubricating oil pan. 		
Action	Specification/Repair	Next Step
<p>Remove the lubricating oil pan. Reference Procedure 007-025 in Section 7 of the appropriate service manual.</p> <p>Check the crankshaft to see if it has been balanced. Reference Procedure 001-016 in Section 16 of the appropriate service manual.</p> <p>This step only applies if the complaint has been present since the engine was new or after a crankshaft replacement.</p> <p>ISX engines built after 01-November-2008 have a marking on the crankshaft to indicate if it passed the balancing step in the manufacturing process. Reference Procedure 001-016 in Section 1 of the appropriate service manual.</p>	<p>Crankshaft balanced? YES</p>	3M
	<p>Crankshaft balanced? NO</p> <p>Repair: Replace the crankshaft. Contact a Cummins® Technical Support/Warranty specialist before proceeding with the repair.</p>	Repair complete

STEP 3M: Check for internal engine damage.

<p>Condition:</p> <ul style="list-style-type: none"> • None. 		
Action	Specification/Repair	Next Step
<p>Contact a support specialist.</p> <p>At this point, a significant amount of labor has been invested in the repair. Before disassembling the engine, seek troubleshooting assistance. Contact the appropriate Technical Support Channel for your facility. They will provide the necessary guidance and schedule on-site support, if deemed necessary.</p> <ul style="list-style-type: none"> • Camshaft journals and number 1 camshaft bushing are severely damaged • Gear train backlash is excessive or the gear teeth are damaged • Idler gear bushing damaged or worn • Main or connecting rod bearing damage • Gears out of balance or gear bushing damage • Connecting rod damage. 	<p>Internal engine damage? YES</p>	Contact Technical Support
	<p>Internal engine damage? NO</p>	Contact Technical Support

STEP 4: Operate the mobile equipment.

STEP 4A: Perform a diagnostic road test.

Condition: <ul style="list-style-type: none"> • Perform diagnostic road test. 		
Action	Specification/Repair	Next Step
Perform a diagnostic road test, observing where the vibration occurs. If the vibration can be duplicated on the road, place the transmission in neutral and allow the engine speed to drop to idle under the road speed conditions of the vibration.	Vibration present during a diagnostic road test? YES	4A-1
	Vibration present during a diagnostic road test? NO	No repair

STEP 4A-1: Perform a diagnostic road test.

Condition: <ul style="list-style-type: none"> • Perform diagnostic road test. 		
Action	Specification/Repair	Next Step
Perform a diagnostic road test, observing where the vibration occurs. If the vibration can be duplicated on the road, place the transmission in neutral and allow the engine speed to drop to idle under the conditions of the vibration.	Vibration present with the transmission in neutral, under the road speed conditions, where the vibration was duplicated driving? YES	4C
	Vibration present with the transmission in neutral, under the road speed conditions, where the vibration was duplicated driving? NO	4B

STEP 4B: Inspect the engine mounts.

Condition: <ul style="list-style-type: none"> • Do not operate engine. • Remove the engine mount isolators. 		
Action	Specification/Repair	Next Step
This step is a detailed inspection of the engine mount brackets, isolators, and mounting hardware. <ul style="list-style-type: none"> • Check the engine mount isolators for installation damage. • Check the alignment of the engine mount brackets. • Check for premature wear on the engine mount isolators and mounting hardware. • If the equipment is new, check for the proper mount specification. Reference Procedure 016-010 in Section 16 of the appropriate service manual.	All steps verified to be correct? YES	4C
	All steps verified to be correct? NO Repair: Repair or replace damaged components.	Repair complete

STEP 4C: Check for drive train components that are worn, unbalanced, malfunctioning, or are not correct.

Condition: • None.		
Action	Specification/Repair	Next Step
Compare the drive train components to the engine and equipment specifications. Isolate the drive train components and check for vibrations. Refer to the OEM service manual.	All steps verified to be correct? YES	Contact Cummins® Technical Support and the OEM
	All steps verified to be correct? NO	Contact Cummins® Technical Support and the OEM

STEP 5: Marine applications.

STEP 5A: Check the gear ratio and propeller configuration.

Condition: • Turn keyswitch OFF.		
Action	Specification/Repair	Next Step
Check for an incorrect matching of the gear ratio and propeller to the engine power. N/A	Gear ratio and the propeller incorrectly matched to the engine power? YES Repair: Contact a Cummins® Distributor or a Marine District Field Service Manager.	Repair complete
	Gear ratio and the propeller incorrectly matched to the engine power? NO	5B

STEP 5B: Check for the correct engine mounting isolators and for proper installation requirements.

Condition: <ul style="list-style-type: none"> • None. 		
Action	Specification/Repair	Next Step
Check for the correct engine mount isolators and for propeller installation requirements. N/A	Engine mount isolators correct and installed correctly? YES	5C
	Engine mount isolators correct and installed correctly? NO Repair: Check for proper isolator installation requirements. Replace and repair vibration isolators as needed. Reference Procedure 016-026 in Section 16 of the appropriate service manual and the Engine Mounting/ Drive Systems section in the Marine Recreational Installation Directions, Bulletin 3884649. If the isolators are not manufactured by Cummins Inc.; see the OEM service manual.	Repair complete

STEP 5C: Check for damaged engine mounts and isolators.

Condition: <ul style="list-style-type: none"> • None. 		
Action	Specification/Repair	Next Step
Inspect the engine mount and isolators for damage. N/A	Engine mounts and isolators in good condition? YES	5D
	Engine mounts and isolators in good condition? NO Repair: Remove and replace the engine mount isolators. Reference Procedure 016-026 in Section 16 of the appropriate service manual and the Engine Mounting/Drive Systems section in the Marine Recreational Installation Directions, Bulletin 3884649. If the isolators are not manufactured by Cummins Inc.; see the OEM service manual.	Repair complete

STEP 5D: Check the exhaust system.

Condition: • None.		
Action	Specification/Repair	Next Step
Check for exhaust system deficiencies. N/A	Exhaust system deficient? YES Repair: Repair or replace as needed. See the Exhaust System section in the Marine Recreational Installation Directions, Bulletin 3884649, and the OEM service manual.	Repair complete
	Exhaust system deficient? NO	5E

STEP 5E: Check the engine driven accessories.

Condition: • Turn keyswitch ON. • Turn keyswitch OFF.		
Action	Specification/Repair	Next Step
Check for engine driven accessory malfunctions. • Isolate or disconnect the accessories and check for vibration. • Do not operate the engine if the sea water pump is disconnected.	Engine driven accessory malfunctioning? YES Repair: Determine the cause of the malfunctioning accessories and correct the problem. See the Exhaust System section in the Marine Recreational Installation Directions, Bulletin 3884649, and the OEM service manual.	Repair complete
	Engine driven accessory malfunctioning? NO	5F

STEP 5F: Check the shaft coupling to gear coupling alignment.

Condition: <ul style="list-style-type: none"> • Turn keyswitch OFF. 		
Action	Specification/Repair	Next Step
Check the shaft coupling to gear coupling alignment. N/A	Shaft coupling to gear coupling misaligned? YES Repair: Repair or replace as needed. Reference Procedure 016-025 in Section 16 of the appropriate service manual and the Engine Mounting/Drive Systems section in the Marine Recreational Installation Directions, Bulletin 3884649, and the gear manufacturer's recommendations.	Repair complete
	Shaft coupling to gear coupling misaligned? NO	5G

STEP 5G: Check the propeller shaft for proper installation.

Condition: <ul style="list-style-type: none"> • None. 		
Action	Specification/Repair	Next Step
Check the propeller shaft for proper installation. N/A	Propeller shaft installed correctly? YES	5H
	Propeller shaft installed correctly? NO Repair: Repair or replace as needed. Reference Procedure 016-025 in Section 16 of the appropriate service manual and the Engine Mounting/Drive Systems section in the Marine Recreational Installation Directions, Bulletin 3884649, and the gear manufacturer's recommendations.	Repair complete

STEP 5H: Check the propeller shaft for straightness.

Condition: • None.		
Action	Specification/Repair	Next Step
Check the propeller shaft for straightness. N/A	Propeller shaft straightness within the OEM specification? YES	5I
	Propeller shaft straightness within the OEM specification? NO Repair: Repair or replace the propeller shaft as needed. Contact an authorized OEM service location.	Repair complete

STEP 5I: Isolate the engine.

Condition: • Disconnect the drive shaft.		
Action	Specification/Repair	Next Step
Run the engine without the drive shaft attached at the coupler. N/A	Engine vibration persist? YES Repair: Check the engine vibration damper for damage. Repair or replace as needed. Reference Procedure 001-052 in Section 1 of the appropriate service manual.	Repair complete
	Engine vibration persist? NO	5J

STEP 5J: Check for strut/cutlass bearing misalignment.

Condition: <ul style="list-style-type: none"> • Turn keyswitch OFF. 		
Action	Specification/Repair	Next Step
Check for strut/cutlass bearing misalignment or strut mounting not secure. N/A	Strut/cutlass bearing misaligned or strut mounting not secure? YES Repair: Check the strut for mounting stiffness. Repair or replace as necessary. Contact an authorized OEM service location.	Repair complete
	Strut/cutlass bearing misaligned or strut mounting not secure? NO	5K

STEP 5K: Is the propeller out of balance or not fitted properly to the shaft?

Condition: <ul style="list-style-type: none"> • None. 		
Action	Specification/Repair	Next Step
Check for propeller out-of-balance or propeller not fitted properly to shaft. N/A	Propeller out of balance or not fitted properly to the shaft? YES Repair: Check the propeller for accuracy. Repair or replace as needed. Contact an authorized OEM service location.	Repair complete
	Propeller out of balance or not fitted properly to the shaft? NO	5L

STEP 5L: Check the V-angle on the V-strut.

Condition: • None.		
Action	Specification/Repair	Next Step
Check to see if the V-angle on the V-strut does not match the angle of the blade on the propeller. N/A	V-angle on the V-strut match the angle of the blade on the prop? YES	5M
	V-angle on the V-strut match the angle of the blade on the prop? NO Repair: Repair or replace as needed. Refer to an Authorized OEM Service Location.	Repair complete

STEP 5M: Check the propeller tunnels.

Condition: • None.		
Action	Specification/Repair	Next Step
Check if the propeller tunnels are properly matched with the propellers. N/A	Entry and exit of the propeller tunnel match with the propeller blades? YES	5N
	Entry and exit of the propeller tunnel match with the propeller blades? NO Repair: Repair or replace as needed. Contact an authorized OEM service location.	Repair complete

STEP 5N: Check the engine-to-transmission torsional coupling.

Condition: • None.		
Action	Specification/Repair	Next Step
Check the engine-to-transmission torsional coupling. N/A	Torsional coupling incorrect or worn? YES Repair: Replace the coupling. Contact an authorized OEM service location.	Repair complete
	Torsional coupling incorrect or worn? NO	5O

STEP 5O: Check the rudder.

Condition: None.		
Action	Specification/Repair	Next Step
Check the rudder for excessive play in the rudder post. N/A	Rudder have excessive play in the rudder post? YES Repair: Repair or replace as needed. Contact an authorized OEM service location.	Repair complete
	Rudder have excessive play in the rudder post? NO	5P

STEP 5P: Check the engine flywheel housing-to-cylinder block alignment.

Condition: • None.		
Action	Specification/Repair	Next Step
Check the engine flywheel housing-to-cylinder block alignment. N/A	Flywheel housing alignment incorrect? YES Repair: Align the flywheel housing to cylinder block. Reference Procedure 016-006 in Section 16 of the appropriate service manual.	Repair complete
	Flywheel housing alignment incorrect? NO Repair: The engine can possibly have internal damage that has not been detected. Analyze the oil and inspect the filters to locate an area of probable damage. Reference Procedure 007-083 in Section 7 of the appropriate service manual. The engine can possibly need to be rebuilt. Reference Procedure 000-001 in Section 0 of the appropriate service manual and the engine rebuild specifications in the appropriate service manual. If the engine is not damaged, the problem can possibly be the vessel design. Contact an authorized OEM service location.	Repair complete

Section DS - Engine Disassembly - Group 00

Section Contents

	Page
Accessory Drive	DS-18
Remove.....	DS-18
Air Compressor	DS-19
Remove.....	DS-19
Time.....	DS-19
Air Intake Connection	DS-26
Remove.....	DS-26
Air Intake Connection Adapter	DS-25
Remove.....	DS-25
Air Intake Manifold	DS-35
Remove.....	DS-35
Alternator	DS-4
Remove.....	DS-4
Alternator Bracket	DS-6
Remove.....	DS-6
Spool Mount.....	DS-6
Pad Mount.....	DS-6
Marine Applications.....	DS-6
Belt Guard	DS-1
Remove.....	DS-1
Block Stiffener Plate	DS-52
Remove.....	DS-52
Camshaft	DS-53
Remove.....	DS-53
Camshaft Bushings	DS-61
Remove.....	DS-61
Camshaft Gear (Camshaft Installed)	DS-53
Remove.....	DS-53
Coolant Thermostat Housing	DS-7
General Information.....	DS-7
Remove.....	DS-8
Coolant Thermostat Housing Support	DS-8
General Information.....	DS-8
Remove.....	DS-8
Coolant Vent Lines	DS-7
Remove.....	DS-7
Crankcase Breather (External)	DS-18
Remove.....	DS-18
Crankcase Breather (Internal)	DS-16
Remove.....	DS-16
Crankcase Breather Tube	DS-12
Remove.....	DS-12
Crankshaft	DS-60
Remove.....	DS-60
Crankshaft Seal, Front	DS-45
Remove.....	DS-45
Crankshaft Seal, Rear	DS-10
Remove.....	DS-10
Crankshaft Speed Indicator Ring	DS-45
Remove.....	DS-45
Crankshaft Wear Sleeve, Rear	DS-15
Remove.....	DS-15
Crosshead	DS-24
Remove.....	DS-24
Cylinder Head	DS-49
Remove.....	DS-49
Cylinder Head Gasket	DS-49

Remove.....	DS-49
ECM Cooling Plate, Fuel Cooled	DS-36
Remove.....	DS-36
ECM Mounting Plate	DS-36
Remove.....	DS-36
Engine Support Bracket, Front	DS-3
Remove.....	DS-3
Engine Support Bracket, Rear	DS-3
Remove.....	DS-3
Exhaust Manifold, Dry	DS-43
Remove.....	DS-43
Fan Hub, Belt Driven	DS-4
Remove.....	DS-4
Fan Spacer and Pulley	DS-4
Remove.....	DS-4
Flexplate	DS-9
Remove.....	DS-9
Flywheel	DS-9
Remove.....	DS-9
Flywheel Housing	DS-14
Remove.....	DS-14
Fuel Connector (Head Mounted)	DS-28
Finishing Steps.....	DS-28
Remove.....	DS-28
Fuel Drain Lines	DS-29
Remove.....	DS-29
Fuel Filter (Spin-On Type)	DS-33
Remove.....	DS-33
Fuel Filter Head	DS-34
Remove.....	DS-34
Low Mount Fuel Filter.....	DS-34
High Mount Fuel Filter.....	DS-34
Marine Applications.....	DS-35
Fuel Lift Pump	DS-37
Remove.....	DS-37
Fuel Pump	DS-38
Remove.....	DS-38
Fuel Rail	DS-27
Remove.....	DS-27
Fuel Supply Lines	DS-31
Remove.....	DS-31
Gear Cover, Front	DS-48
Remove.....	DS-48
Gear Housing, Front	DS-55
Remove.....	DS-55
Gear Housing, Rear	DS-56
Remove.....	DS-56
Injector	DS-50
Finishing Steps.....	DS-50
Preparatory Steps.....	DS-50
Remove.....	DS-50
Injector Supply Lines (High Pressure)	DS-27
Remove.....	DS-27
Lubricating Oil Cooler	DS-42
Remove.....	DS-42
Lubricating Oil Dipstick Tube	DS-4
Remove.....	DS-4
Lubricating Oil Filter (Spin-On)	DS-41
Remove.....	DS-41
Lubricating Oil Lines	DS-2
Remove.....	DS-2
Lubricating Oil Pan	DS-51
Remove.....	DS-51
Lubricating Oil Pump	DS-49

Remove.....	DS-49
Lubricating Oil Suction Tube (Block-Mounted)	DS-52
Remove.....	DS-52
Piston and Connecting Rod Assembly	DS-57
Remove.....	DS-57
Piston Cooling Nozzle	DS-56
Remove.....	DS-56
Push Rods or Tubes	DS-24
Remove.....	DS-24
Rocker Lever	DS-24
Remove.....	DS-24
Rocker Lever Cover	DS-20
Remove.....	DS-20
Rocker Lever Housing	DS-23
Remove.....	DS-23
Sea Water Pump Pulley	DS-2
Remove.....	DS-2
Starting Motor	DS-8
Remove.....	DS-8
Tappet	DS-55
Remove.....	DS-55
Turbocharger	DS-42
Remove.....	DS-42
Turbocharger Oil Drain Line	DS-42
Remove.....	DS-42
Turbocharger Oil Supply Line	DS-41
Remove.....	DS-41
Vibration Damper, Rubber	DS-44
Remove.....	DS-44
Vibration Damper, Viscous	DS-45
Remove.....	DS-45
Water Inlet Connection	DS-44
Remove.....	DS-44
Water Pump	DS-44
Remove.....	DS-44

This Page Left Intentionally Blank

Belt Guard (008-001)

Remove

Remove the two wing nuts (A) and three capscrews (B) on the sea water pump belt guard.

Remove the upper belt guard.

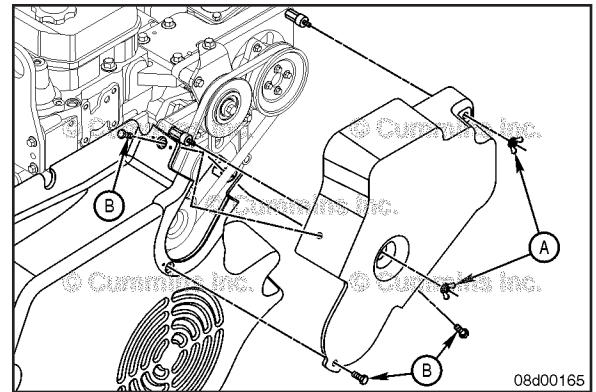

Remove the three wing nuts on the alternator/engine water pump belt guard.

Remove the lower belt guard.

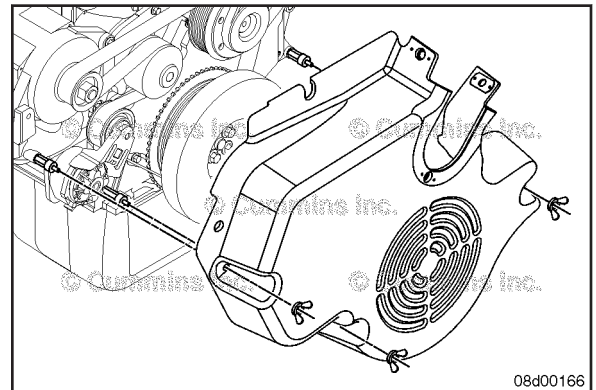

Remove the five rubber isolators from the upper and lower belt guard mounting studs.

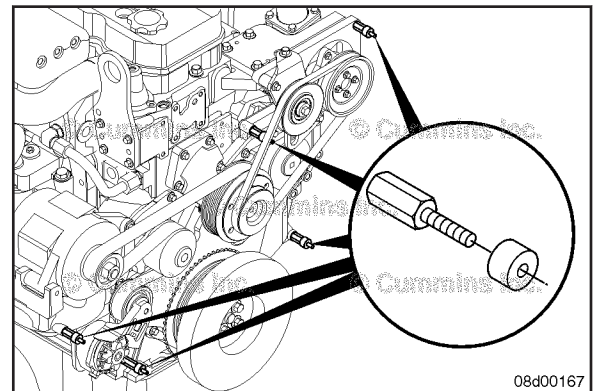

NOTE: Two of the studs are attached with nuts from the rear side of the gear housing.

Remove the locknut, if applicable.

Remove the stud.

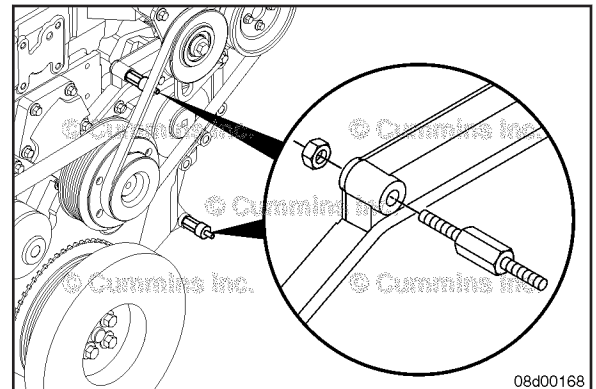

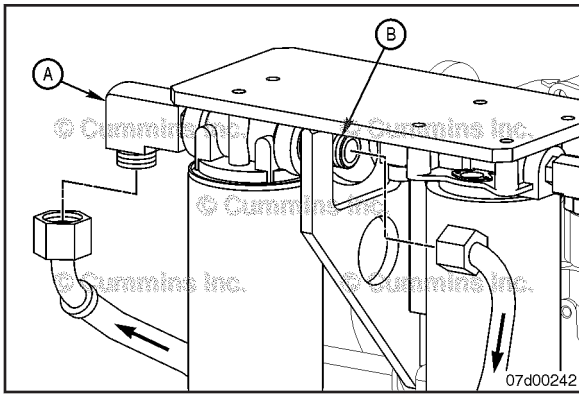

Lubricating Oil Lines (007-092)

Remove

⚠ WARNING ⚠

To reduce the possibility of personal injury, avoid direct contact of hot oil with your skin.

⚠ WARNING ⚠

Some state and federal agencies have determined that used engine oil can be carcinogenic and cause reproductive toxicity. Avoid inhalation of vapors, ingestion, and prolonged contact with used engine oil. If not reused, dispose of in accordance with local environmental regulations.

⚠ CAUTION ⚠

Use caution when draining oil that oil is not spilled or drained into the bilge area. The oil must be disposed in accordance with local environmental regulations.

⚠ CAUTION ⚠

Before disconnecting the lubricating oil lines, tag the oil lines for correct location to prevent filter and engine damage due to incorrect installation.

Verify and mark the oil hoses and oil filter head for correct location.

- Oil inlet
- Oil outlet.

Disconnect the oil lines from the lubricating oil filter head.

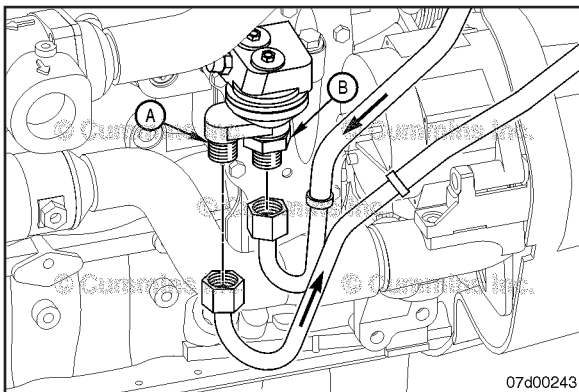

Verify and mark the oil hoses and adapter head for correct location.

- Oil outlet
- Oil inlet.

Disconnect the oil lines from the adapter head.

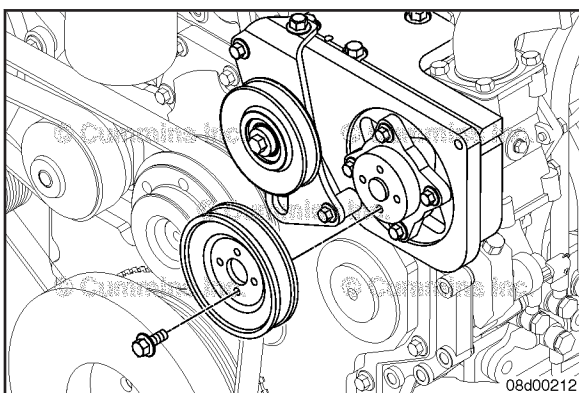

Sea Water Pump Pulley (008-127)

Remove

Remove the four mounting capscrews and the sea water pump pulley.

Engine Support Bracket, Front (016-002)



Remove

For Front Mount, remove the front mount capscrews and bracket.

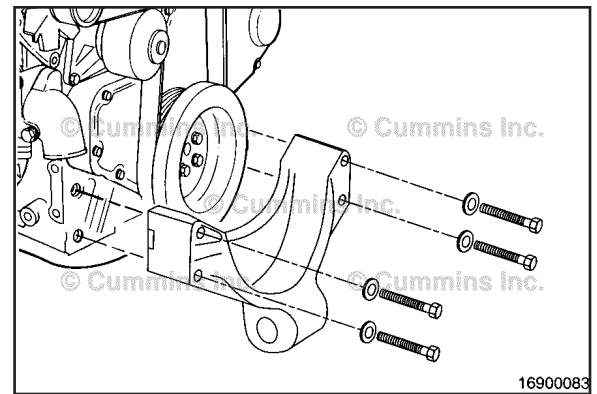

For Side Mount, remove the side engine mount capscrews and the brackets.

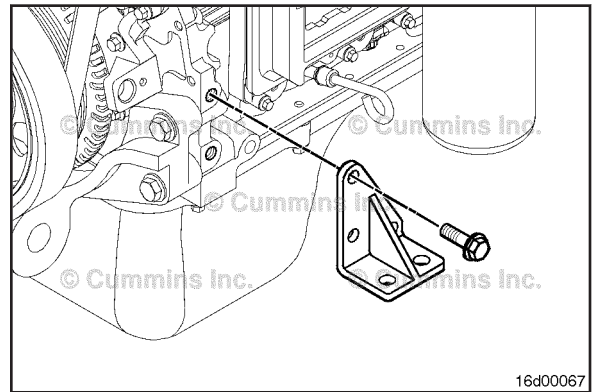

Remove the side engine mount capscrews and the brackets.

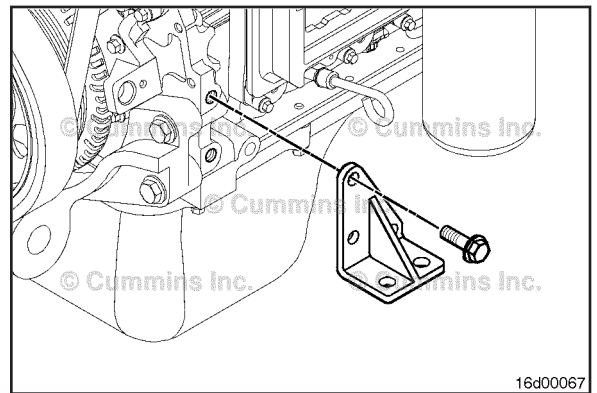

Engine Support Bracket, Rear (016-003)



Remove

Remove the rear support capscrews and bracket.

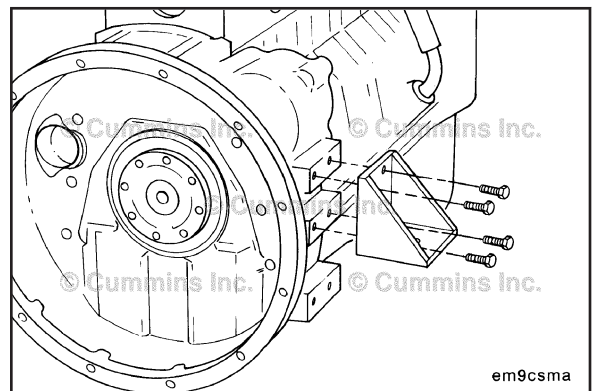

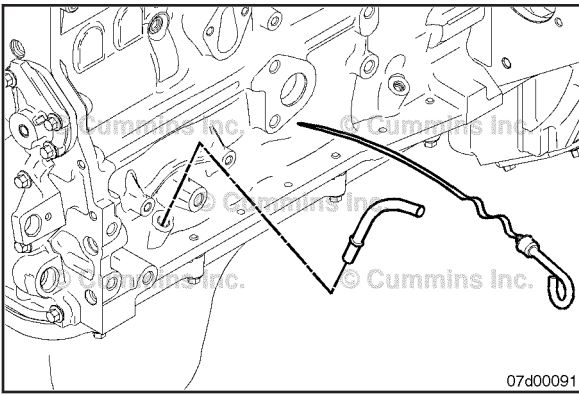

Lubricating Oil Dipstick Tube (007-011)

Remove

Remove dipstick from the dipstick tube.

Remove dipstick tube from the cylinder block.

Service Tip: Use a dent puller and M8 x 1.25 x 21-mm self-tapping capscrew. Thread the capscrew into the dipstick tube, and remove the tube.

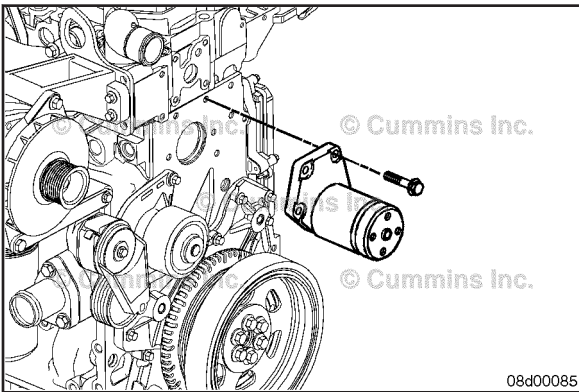

Fan Hub, Belt Driven (008-036)

Remove

Remove the four fan hub mounting capscrews.

Remove the fan hub.

NOTE: There are many available fan hub configurations. Be sure to note the location, orientation, and mounting pattern of the hub prior to removal from the engine.

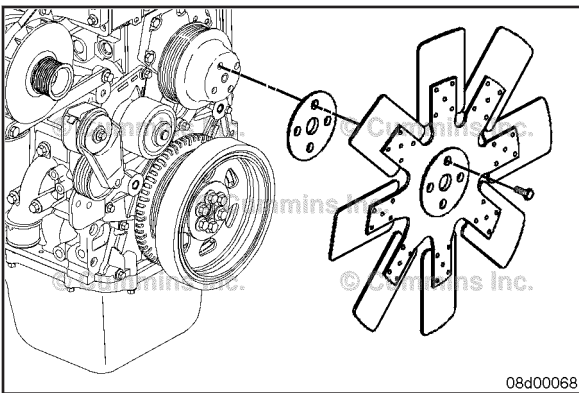

Fan Spacer and Pulley (008-039)

Remove

Remove the four fan capscrews, fan, and spacer.

Remove the cooling fan drive belt. Refer to Procedure 008-002 (Drive Belt, Cooling Fan) in Section 8.

Remove the fan pulley.

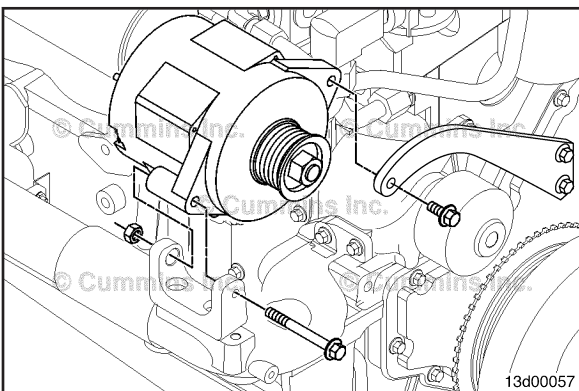

Alternator (013-001)

Remove

Spool Mount

Remove the upper alternator link capscrew.

Remove the mounting capscrew and nut at the bottom of the alternator and alternator mounting bracket.

Remove the alternator.

Pad Mount

Remove the alternator mounting capscrews.

Remove the alternator.

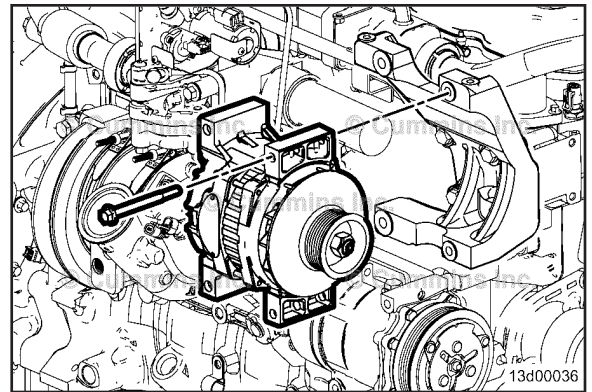

Hinge Mount

Remove the alternator link capscrew.

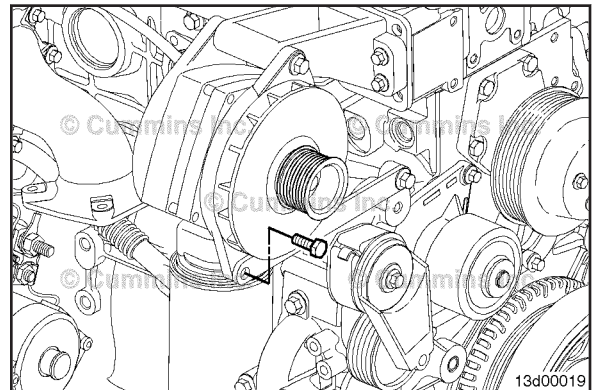

Remove the alternator mounting capscrew.

Remove the alternator.

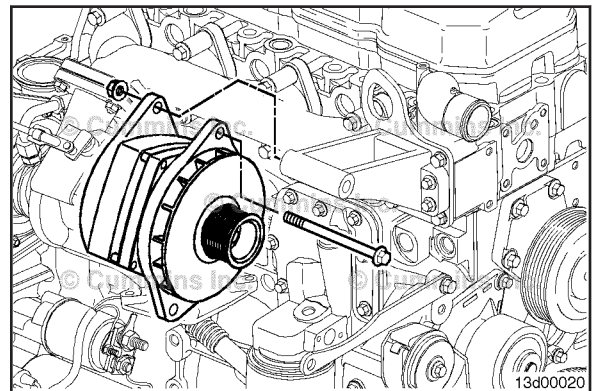

Marine Applications

Remove the capscrew from the top of the alternator and alternator link.

Remove the mounting capscrew at the bottom of the alternator and alternator mounting bracket.

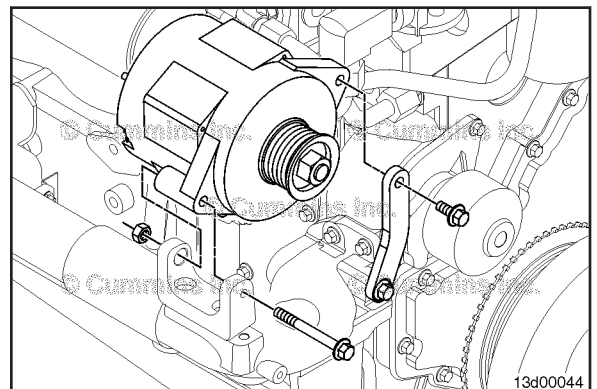

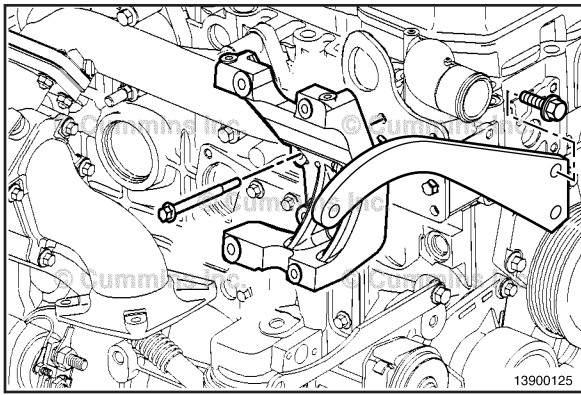

Alternator Bracket (013-003)

Remove Spool Mount

NOTE: On some applications, the alternator bracket and water inlet are combined in the same bracket. Refer to Procedure 008-082, where applicable.

Remove the upper alternator bracket mounting capscrews.

Remove the lower alternator bracket mounting capscrews.

Remove the alternator bracket.

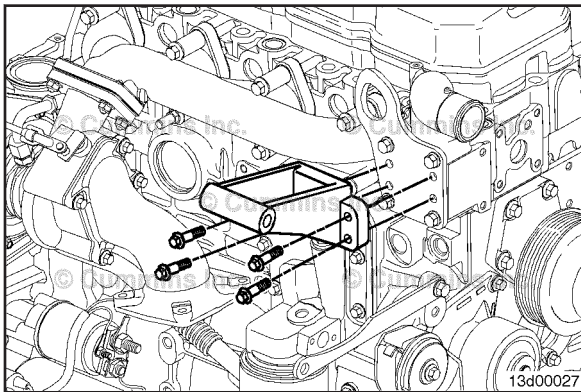

Hinge Mount:

Remove the upper alternator bracket mounting capscrews.

Remove the lower alternator bracket mounting capscrews.

Remove the alternator bracket.

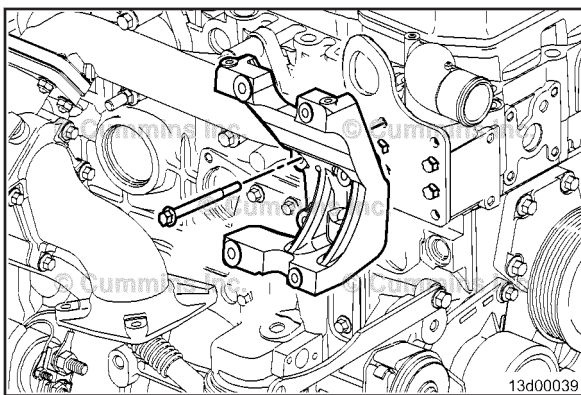

Pad Mount

Remove the alternator bracket mounting capscrews.

Remove the alternator bracket.

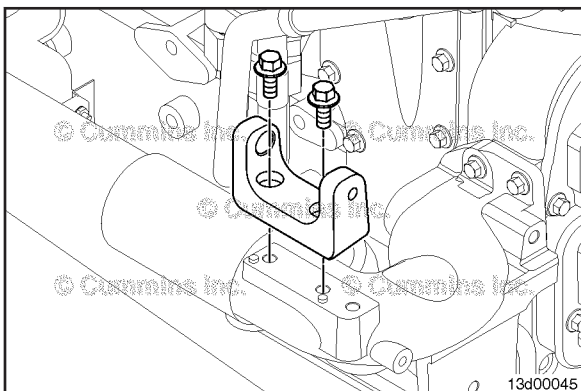

Marine Applications

Remove the two alternator mounting bracket capscrews.

Remove the alternator mounting bracket.

Coolant Vent Lines (008-017)

Remove

Disconnect the exhaust manifold coolant vent line from the expansion tank and the top of the exhaust manifold.

Disconnect the turbocharger coolant vent line from the top of the expansion tank.

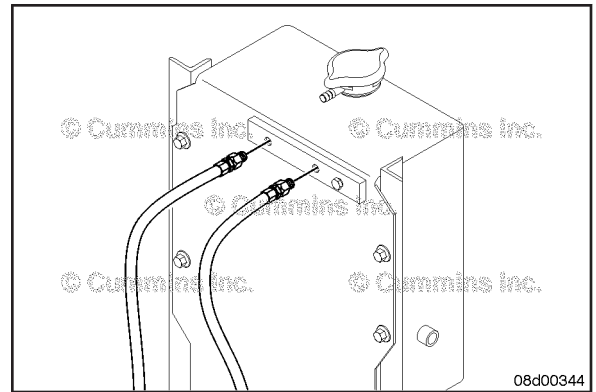

Disconnect the turbocharger coolant vent line from the top of the turbocharger.

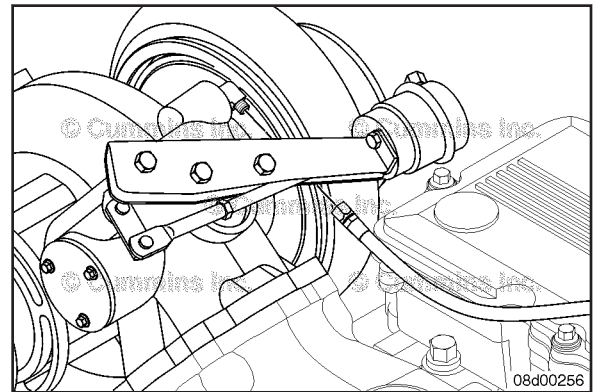

Disconnect the coolant vent line from the top of the expansion tank and the top of the thermostat housing.

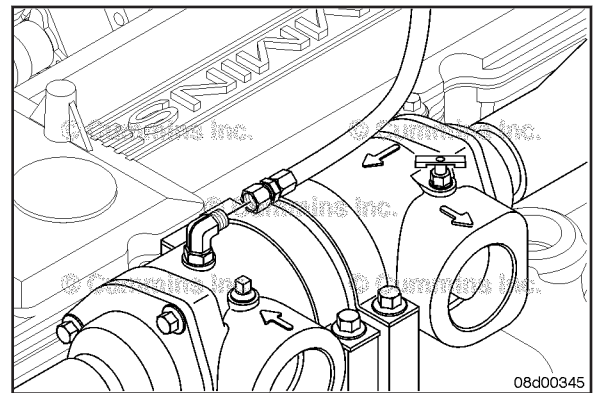

Coolant Thermostat Housing (008-014)

General Information

This procedure applies to QSB5.9 keel cooled engines
only

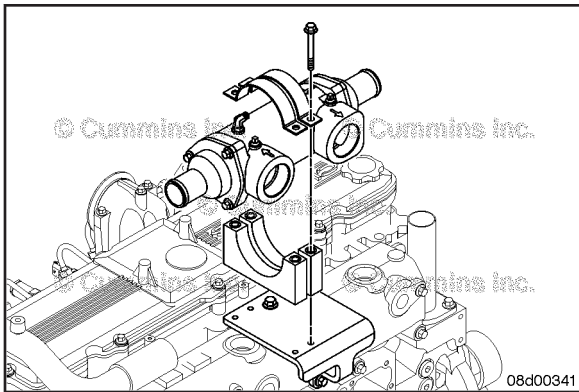

Remove

Remove the four thermostat housing mounting capscrews.

Remove the two clamps and the thermostat housing.

Remove the two vibration isolators.

Coolant Thermostat Housing Support (008-015)

General Information

This procedure applies to QSB5.9 marine keel cooled engines **only**

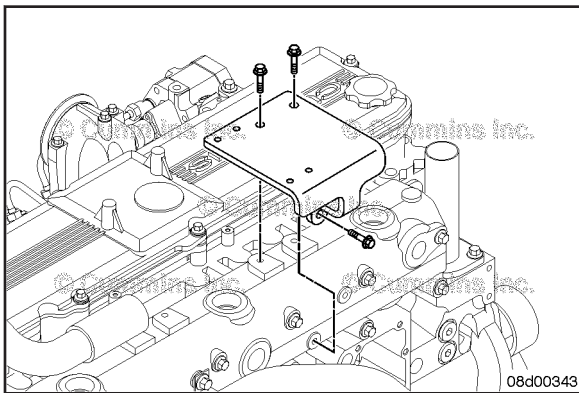

Remove

Remove the three thermostat housing support mounting capscrews and the thermostat housing support.

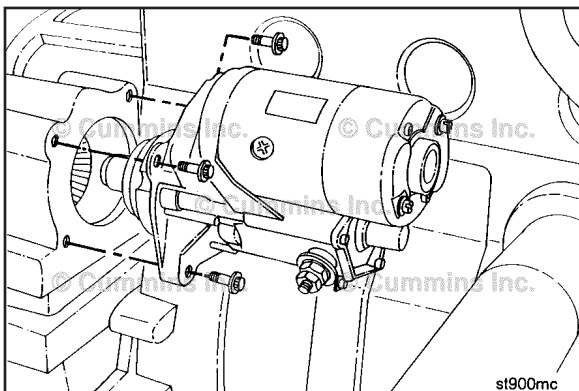

Starting Motor (013-020)

Remove

Remove the three capscrews and the starting motor.

NOTE: If equipped with a starting motor spacer, remove the spacer and clean all surfaces between the starting motor, starting motor spacer, and flywheel housing with a wire brush.

Flexplate (016-004)

Remove

Remove the flexplate capscrews and flexplate.

NOTE: Some flexplates require mounting plates and/or adapters. It may be necessary to remove any mounting plates and/or adapters prior to or with the flexplate. Make sure to note the location of any mounting plates and/or adapters for later installation.

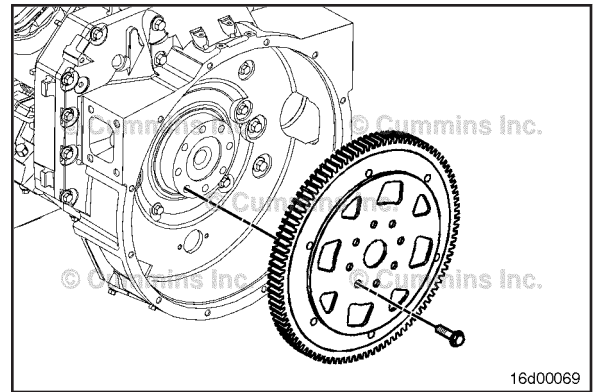

Remove the nine flex-coupling guard capscrews, harness connector, and the flex-coupling guard (if equipped).

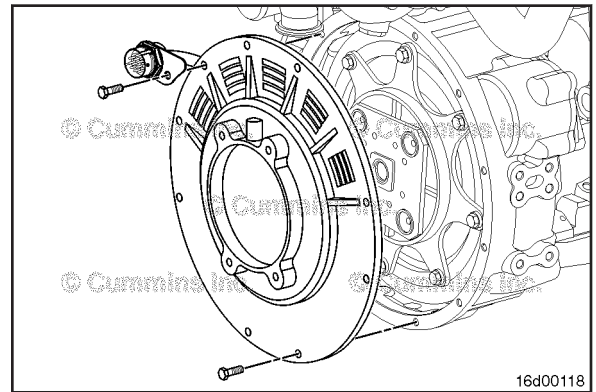

Remove the flexplate mounting capscrews.
Remove the flexplate from the flywheel.

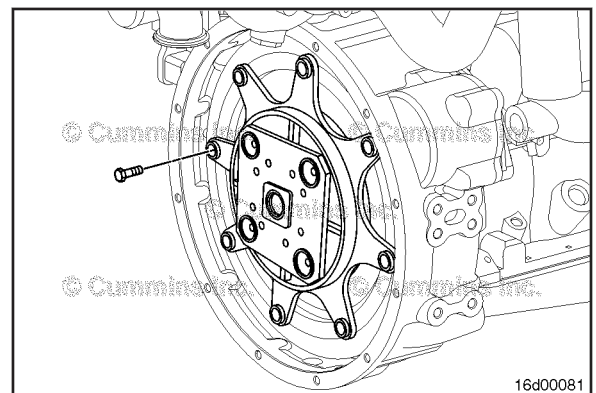

Flywheel (016-005)

Remove

NOTE: Use the barring tool, Part Number 3824591, to hold the flywheel to prevent rotation.

Remove two capscrews 180 degrees apart.

Install two M12 x 1.25 x 90-mm guide pins.

NOTE: If a clutch is used in the equipment, the threads in the clutch pressure plate mounting capscrew holes can be metric or standard. Be sure to use the correct capscrews.

Determine the capscrew thread design and size, and install two T-handles in the flywheel at points (1 and 2).

Remove the remaining six flywheel mounting capscrews.

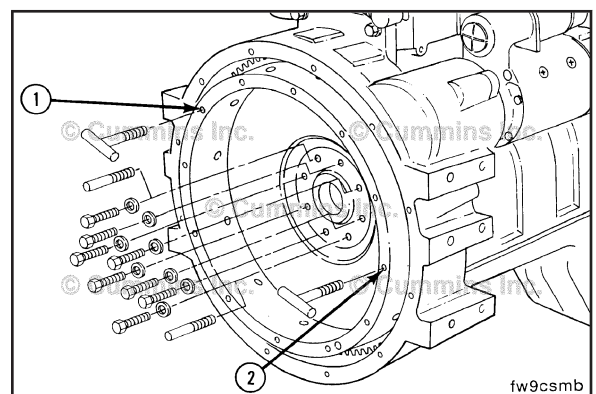

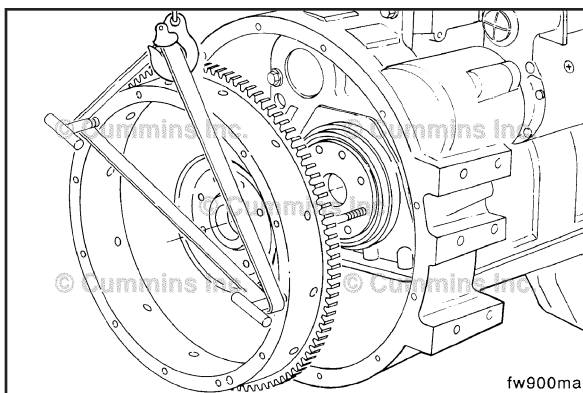

WARNING

This component weighs 23 kg [50 lb] or more. To reduce the possibility of personal injury, use a hoist or get assistance to lift this component.



Remove the flywheel from the guide pins.

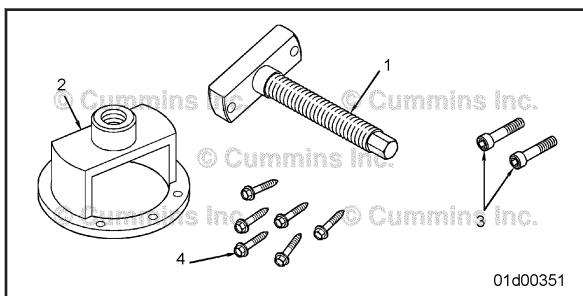

Crankshaft Seal, Rear (001-024)

Remove

Rear Gear Train Engines with Unitized Seals

Use service tool, Part Number 3164660, to remove the seal.

Table 1. Rear Crankshaft Seal Replacer Kit, Part Number 3164660

Item Number	Part Number	Description	Quantity
1	3164666	Replace screw assembly	1
2	3164664	Crankshaft seal replacer	1
3	3164174	Socket head capscrew, M12 x 1.25 x 25 mm	2
4	3164217	Sheet metal screw, Number 10 x 25.4 mm [1 in] long	25 (7 shown)
Not shown	3164218	Drill. 3.57 mm [9/64 in]	1

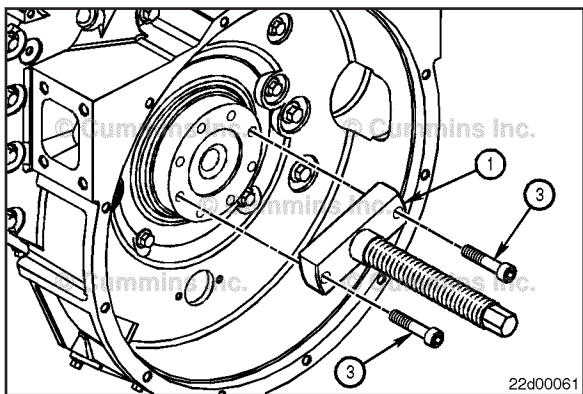

Mount the replacer screw assembly (1) onto the crankshaft nose.

Install the two M12 x 1.25 x 60-mm socket head capscrews (3).

Lubricate the replacer screw with anti-seize compound or a suitable grease.

Hold the replacer screw and install the crankshaft seal replacer (2) onto the replacer screw assembly. Advance the crankshaft seal replacer toward the seal by rotating it **clockwise** until it is positioned against the flywheel housing.

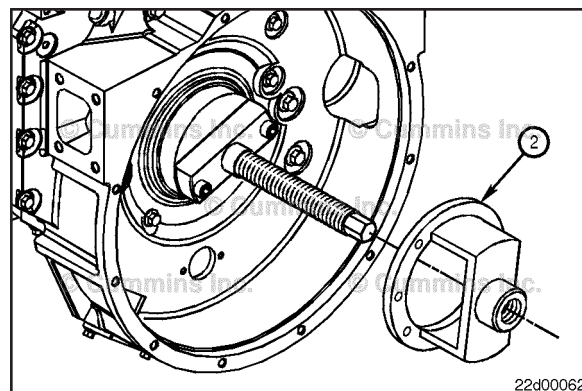

22d00062

⚠ CAUTION ⚠

Drill the hole carefully and straight to reduce the possibility of damage to the flywheel housing or the crankshaft.

Service Tip: Because of space restrictions, it may be necessary to use a compact right angle drill. Also, it may be necessary to shorten the drill bit used to drill the sheet metal screw holes.

NOTE: The flange of the crankshaft seal replacer is 12 mm [0.47 in] thick.

Mark the drill to a depth of 22 mm [0.71 in] with tape for drill depth control and apply grease to the drill to catch the chips. Stop frequently to remove the chips.

With the crankshaft seal replacer positioned against the flywheel housing, drill one hole 10 mm [0.39 in] deep. Make sure the marking tape has **not** moved from the original position.

Install one sheet metal screw (4) into the seal to hold the crankshaft seal replacer in position.

Drill five additional holes 10 mm [0.39 in] deep and install the additional five sheet metal screws.

NOTE: Make sure all six sheet metal screws are threaded through both the inner and outer seal casings. The sheet metal screws need to be uniformly tightened in order to pull out the inner and outer casings of the seal together.

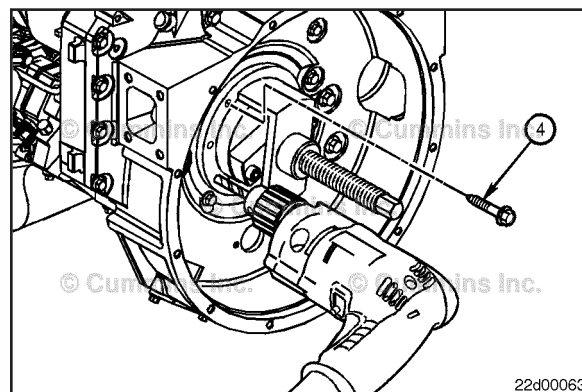

22d00063

⚠ CAUTION ⚠

Do not use an impact wrench or air tools. Doing so can damage the tool.

Slowly rotate the replacer screw **clockwise** until the seal is removed. Do **not** exceed torque value.

Torque Value: 45 N•m [33 ft-lb]

NOTE: If the sheet metal screws pull out of the seal or **only** the inner casing pulls out, stop the removal operation. Rotate the replacer screw **counterclockwise** to force the inner casing back. Remove the sheet metal screws, slightly reorient the tool, drill new holes, and install the sheet metal screws in the new locations.

Complete the removal procedure, remove the tool, and discard the old seal.

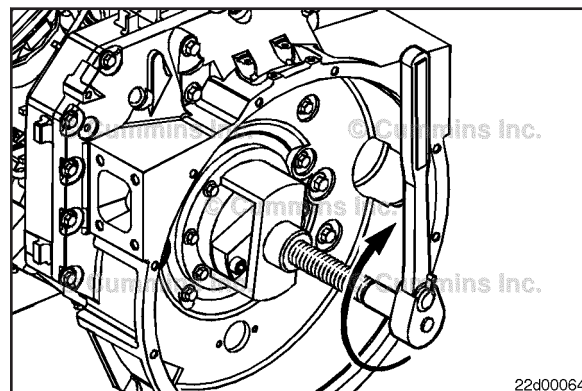

22d00064

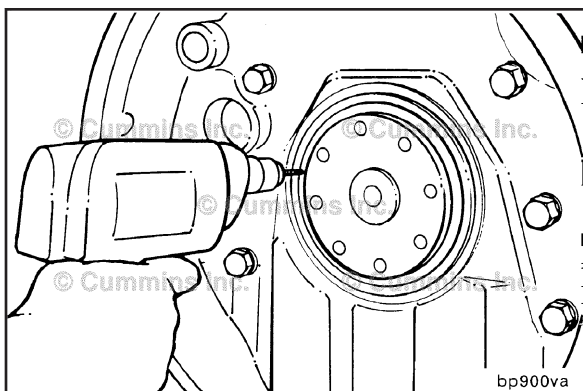

Lip Seal

NOTE: For engines equipped with a lip style rear crankshaft seal, the seal can also be removed using screws and a slide hammer. This procedure should **not** be followed on an engine with a unitized seal.

Drill two (2) holes 180-degrees apart into the seal carrier.

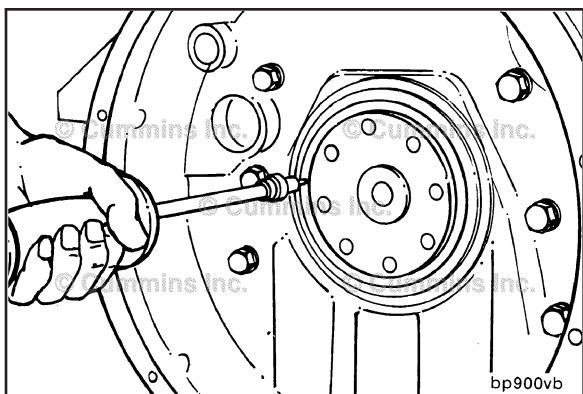

Install two coarse thread sheet metal screws in the holes just drilled. Use a slide hammer to remove the rear crankshaft seal.

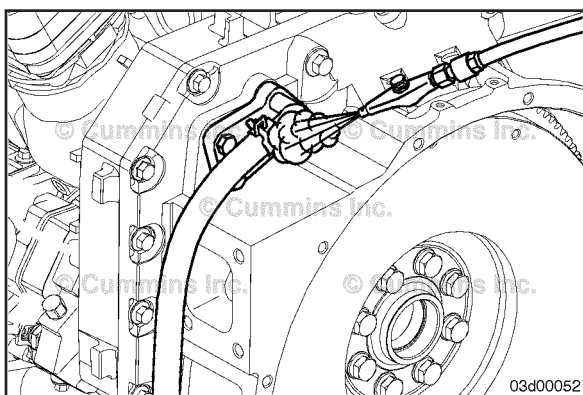

Crankcase Breather Tube (003-018) Remove

▲ WARNING ▲
Wear appropriate eye and face protection when using compressed air. Flying debris and dirt can cause personal injury.

Clean the area around the breather tube connection with compressed air.

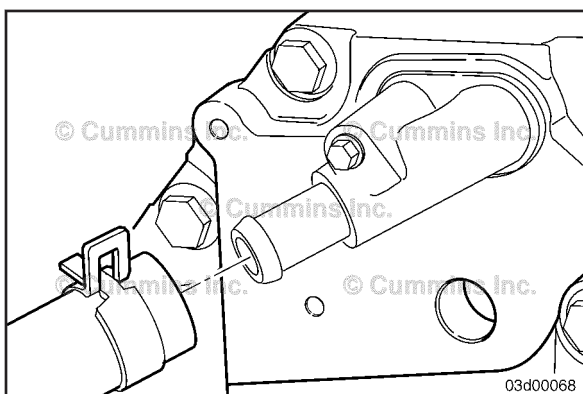

If equipped, remove and note the locations of any p-clips securing the crankcase breather tube.

Remove the hose clamp, if equipped, and disconnect the crankcase breather tube.

Remove the crankcase breather tube.

NOTE: On rear gear train engines, various adapters are used to connect the crankcase breather tube to the flywheel housing.



Breather Tube Adapter

Remove the one capscrew and the breather tube adapter located on the flywheel housing.

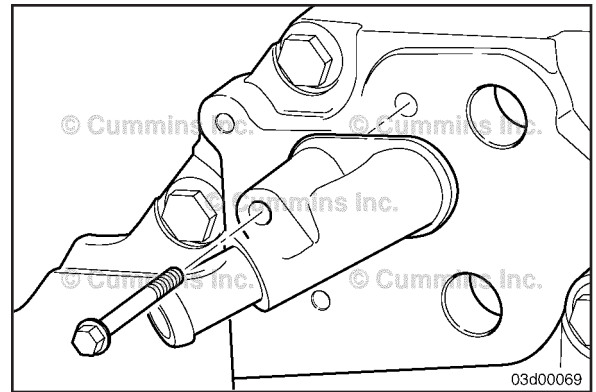

Breather Tube Mounting Plate Adapter

Remove the three capscrews and the breather tube mounting plate.

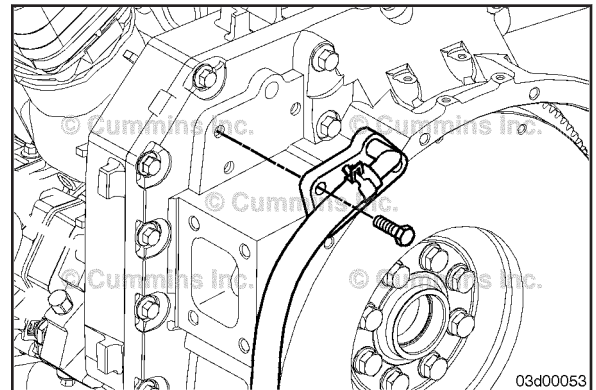

Clamp Plate Breather Tube Adapter

Remove the capscrew securing the clamp plate to the flywheel housing.

Remove the clamp plate.

Remove the breather tube adapter.

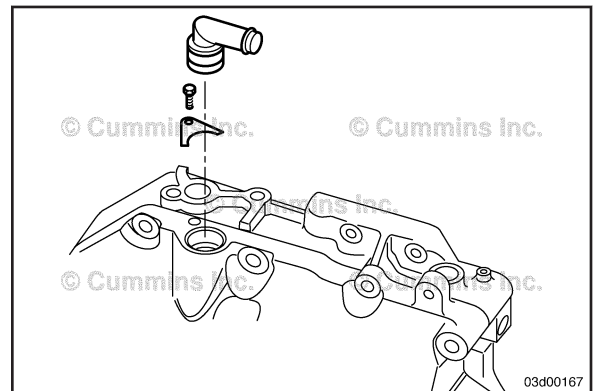

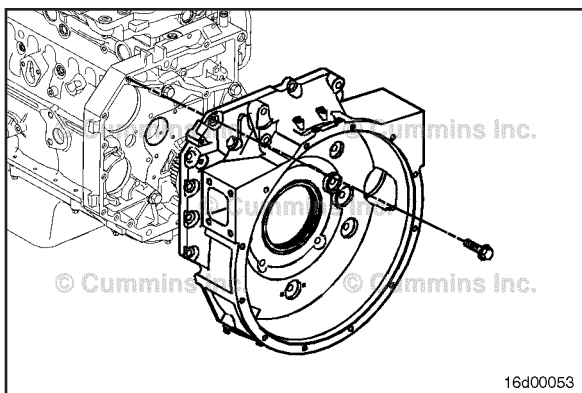

Flywheel Housing (016-006)

Remove

▲ WARNING ▲

This component weighs 23 kg [50 lb] or more. To reduce the possibility of personal injury, use a hoist or get assistance to lift this component.

Loosen the flywheel housing capscrews, but do **not** remove.

Using a rubber hammer, loosen the flywheel housing so that the seal is broken between the flywheel housing and rear gear housing.

While supporting the flywheel housing, remove the mounting capscrews and the flywheel housing.

Note the location of the flywheel housing capscrews as removed. Some of the capscrews are different length/size fasteners and **must** be installed in the same location as removed.

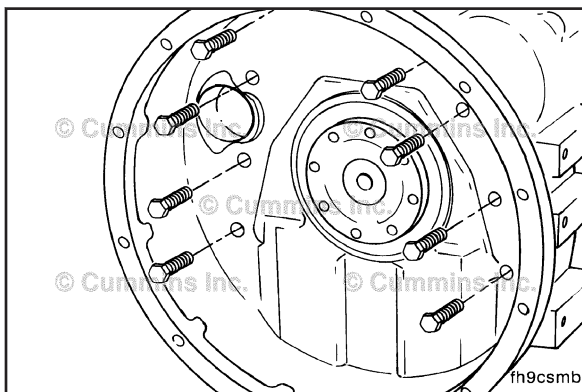

▲ WARNING ▲

This component weighs 23 kg [50 lb] or more. To reduce the possibility of personal injury, use a hoist or get assistance to lift this component.

While supporting the flywheel housing, remove the mounting capscrews.

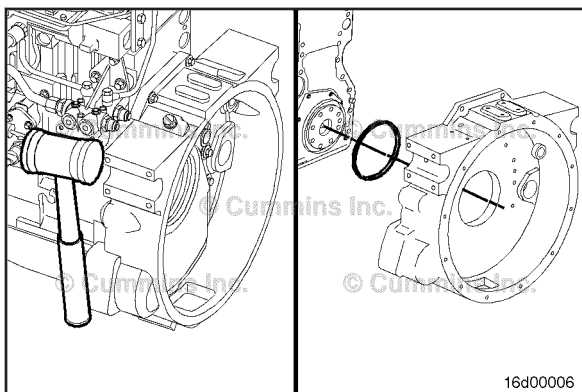

While supporting the flywheel housing, use a rubber hammer to loosen the flywheel housing.

Remove the flywheel housing.

NOTE: Some engines may have an additional rectangular seal between:

- 1 The flywheel housing and the rear seal carrier
- 2 The flywheel housing and camshaft journal bore of the block.

NOTE: When removing the flywheel housing, note the location of any locating dowel rings.

Crankshaft Wear Sleeve, Rear (001-067)

Remove

Remove the four oil pan mounting capscrews that secure the oil pan to the rear cover.

⚠CAUTION⚠

Use extreme care when releasing the oil pan gasket from the rear cover to prevent damage to the gasket. If the gasket is damaged, the oil pan must be removed and the gasket replaced. Refer to Procedure 007-025

Insert the feeler gauge or shim stock between the rear cover and the oil pan gasket. Move the feeler gauge back and forth to release the gasket from the rear cover.

Remove the capscrews from the rear cover.

Remove the cover from the crankshaft flange.

Support the rear seal carrier on a flat work surface with wooden blocks, and using a suitable punch and hammer, drive the old seal out of the rear seal carrier.

⚠CAUTION⚠

Do not nick or gouge the crankshaft with the chisel. If the crankshaft is damaged, it must be replaced.

NOTE: For rear gear train engines, if a wear sleeve has previously been installed, the flywheel housing **must** be removed to remove the wear sleeve. After removing the wear sleeve, reinstall the flywheel housing. Refer to Procedure 016-006

If a wear sleeve has previously been installed, use a dull chisel that is **only** as wide as the wear sleeve.

Make one or two soft blows with a hammer to make chisel marks across the wear sleeve. This will expand the wear sleeve, allowing the sleeve to be removed.

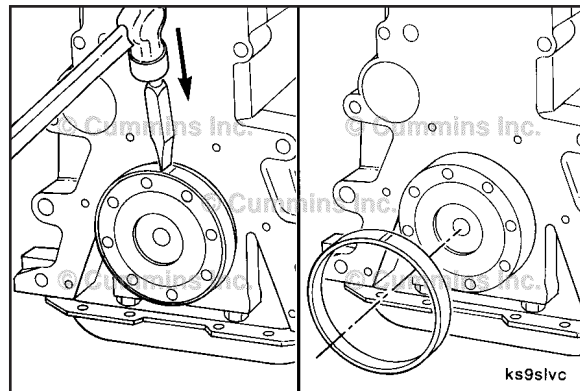
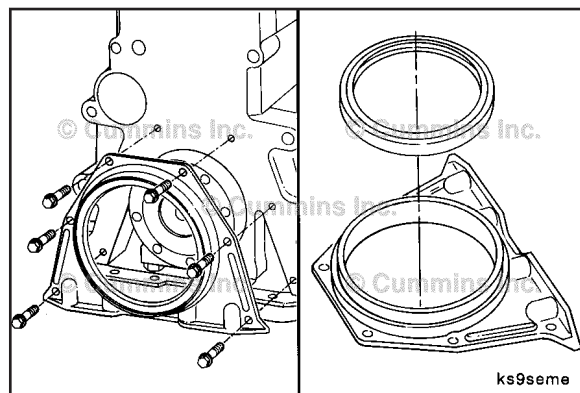
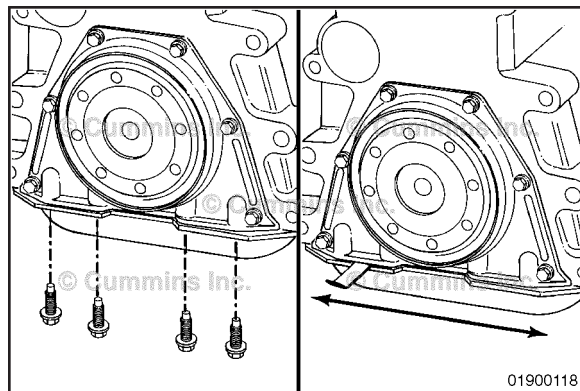

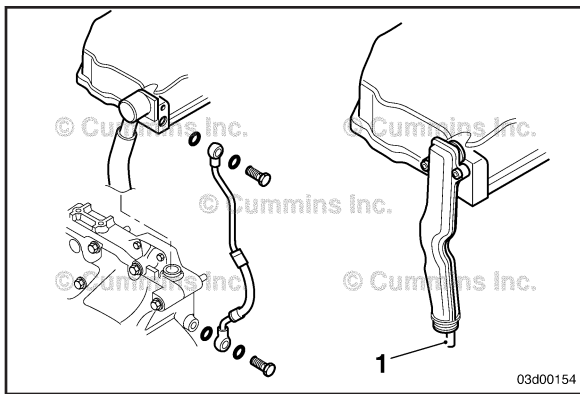

Crankcase Breather (Internal) (003-002)

Remove

If equipped, remove the breather oil drain line which is located at the rear of the engine on the exhaust side of the engine.

Remove the breather oil drain line connections:

- 1 Remove the oil drain line banjo bolt and sealing washers from the rear of the rocker lever cover
- 2 Remove the oil drain line banjo bolt and sealing washers from the rear gear housing
- 3 Remove the breather oil drain line.

NOTE: Not all engines with an internal mounted crankcase breather are equipped with an external breather oil drain line. On some engines the breather oil drain line is internal to the breather connection tube (1).

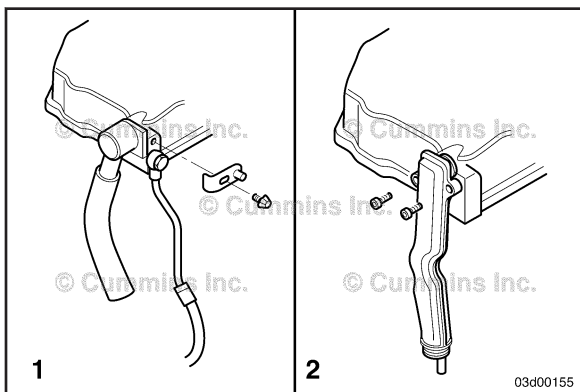

Disconnect the breather tube connection at the back of the rocker lever cover.

In general, two type of breather tube connections are used at the rocker lever cover:

- 1 A clamping plate and capscrew hold the breather tube connection to the rocker lever cover. Remove the capscrew and clamping plate to disconnect the breather tube connection from the rocker lever cover.
- 2 1 or 2 Capscrew(s) directly mount the breather tube connection to the rocker lever cover. Remove the capscrew(s) to disconnect the breather tube connection from the rocker lever cover.

NOTE: Some breather tube connections use internal torx capscrews to secure the breather tube connection to the rocker lever cover.

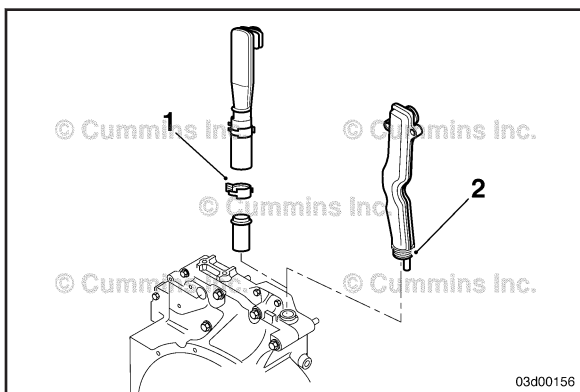

Remove the breather tube connection from the rear gear housing.

In general, two type of breather tube connections are used at the rear gear housing:

- 1 An o'ring sealed connection. Remove the breather tube connection by pulling straight up
- 2 A clamped hose. Remove/loosen the clamp and pull straight up on the hose to remove the breather tube connection.

Remove the breather oil drain back tube banjo bolt from the rear of the rocker lever cover.
Loosen and remove the closed crankcase breather system hose.

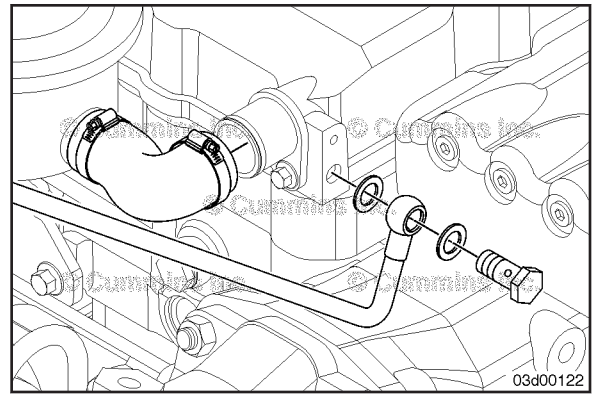

Remove the p-clamp on the oil drain back tube from the side of the engine block.

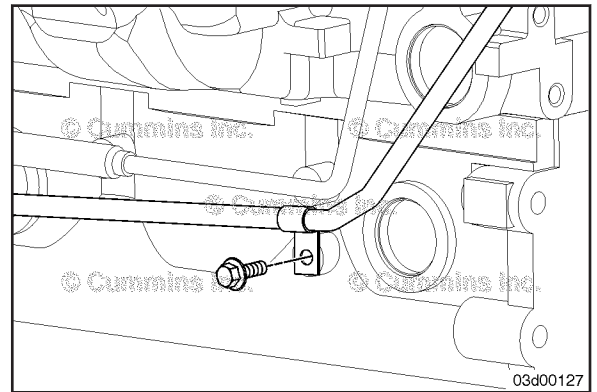

Disconnect the breather oil drain back tube fitting from the check valve on the side of the engine block.
Remove the breather oil drain back tube.

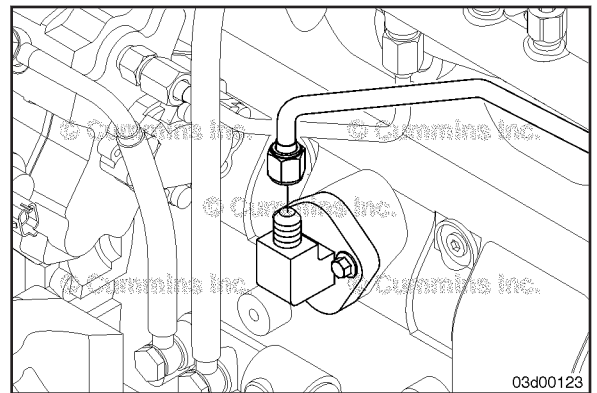

Remove the check valve from the side of the engine by removing the two capscrews and the connection block.

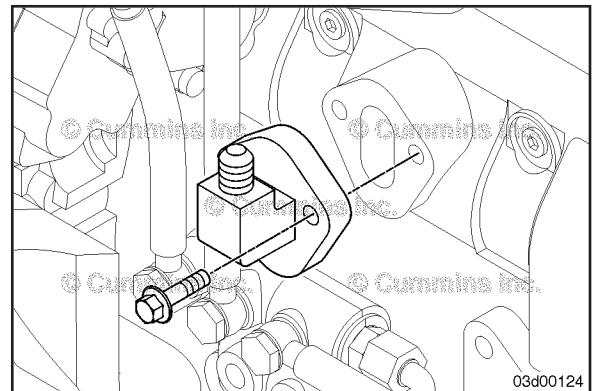

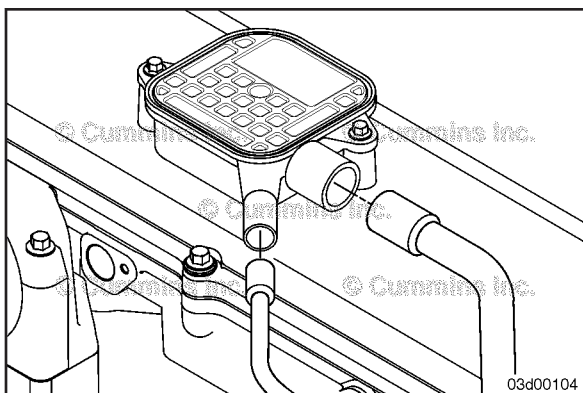

Crankcase Breather (External) (003-001)

Remove

NOTE: It may be necessary to remove an engine cover to access the crankcase breather/rocker lever cover. Refer to the OEM instructions.

Disconnect the crankcase breather tube from the crankcase breather assembly.

Disconnect the crankcase breather oil drain line from the crankcase breather assembly.

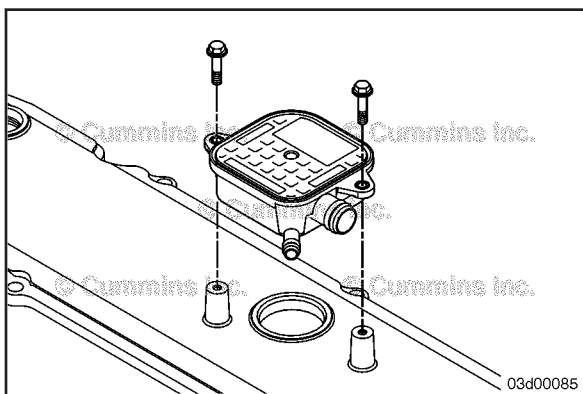

Remove the two mounting capscrews.

Remove the breather from the rocker lever cover by pulling straight up on the breather assembly.

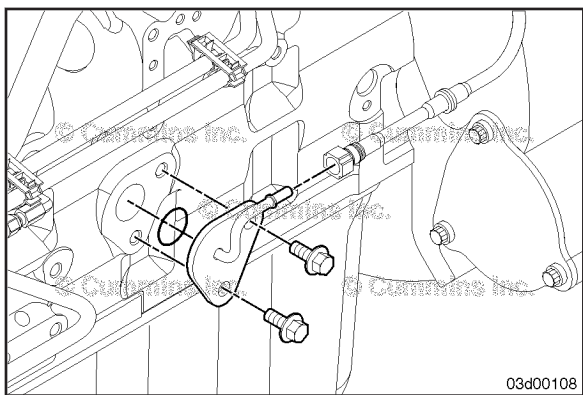

If equipped, remove and note the locations of any p-clips securing the breather oil drain line.

Disconnect the breather oil drain line from the drain fitting on the cylinder block mounted cover plate.

Remove the breather oil drain line.

Remove the capscrews, cover plate, and gasket from the cylinder block.

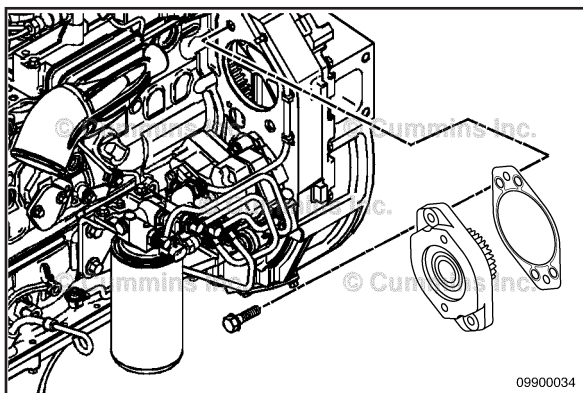

Accessory Drive (009-001)

Remove

Remove the two capscrews securing the accessory drive to the rear gear housing.

Remove the accessory drive and gasket.

Air Compressor (012-014)

Remove

Remove the air compressor support bracket and capscrews from the rear of the compressor.

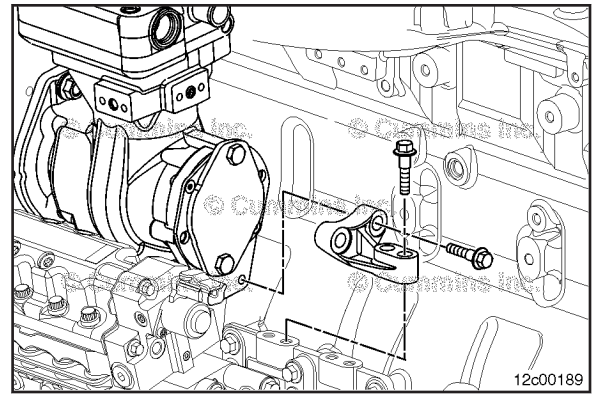

Remove the mounting nut, capscrew, and air compressor.
Discard the gasket.

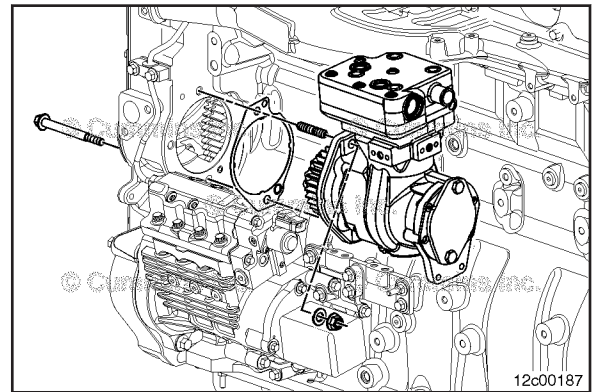

Time

NOTE: To make sure the air compressor does **not** contribute to engine vibrations when installed, the air compressor **must** be properly timed to the engine.

Use the barring tool, Part Number 3824591, or equivalent, to rotate the crankshaft until the number 1 is at top dead center (TDC).

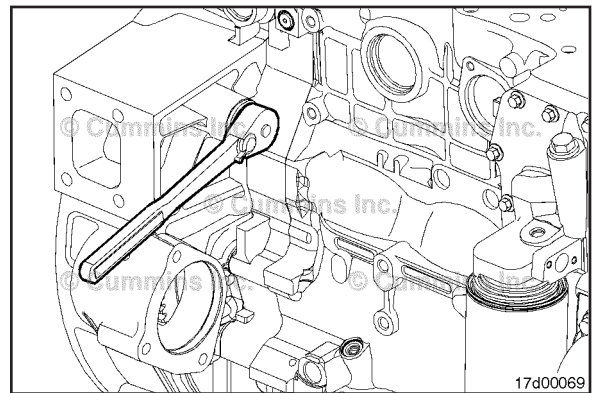

Align the vibration damper so that the TDC indicator on the vibration damper is at the 12-o'clock position.

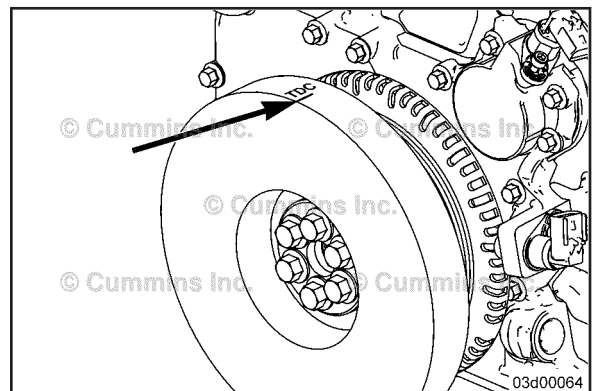

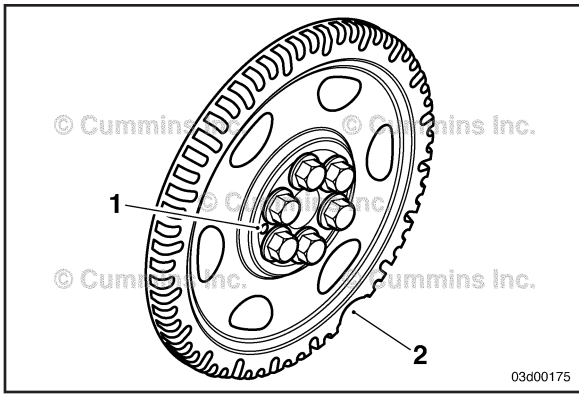

NOTE: If no TDC mark is present on either the vibration damper or the crankshaft speed indicator ring, align the large gap in the crankshaft speed indicator ring to the 5-o'clock position (2). The dowel pin can also be visible in the 9-o'clock position (1).

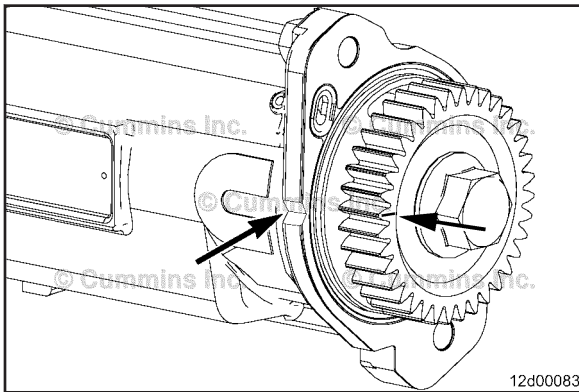

Wabco™ Air Compressors

Set the timing mark on the air compressor gear to the 9-o'clock position when looking at the gear. It **must** point at the casting depression on the side of the air compressor mounting flange.

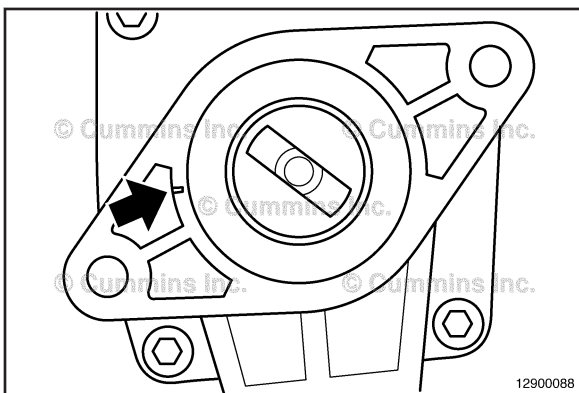

Knorr-Bremse™ Air Compressors

Set the air compressor to TDC by aligning the two timing marks on the rear of the compressor and on the rear drive.

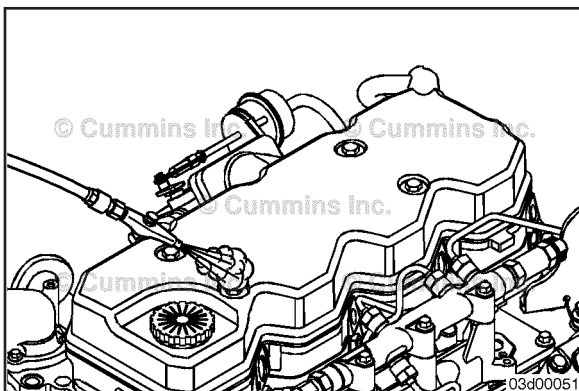

Rocker Lever Cover (003-011)

Remove



WARNING
Wear appropriate eye and face protection when using compressed air. Flying debris and dirt can cause personal injury.

Prior to removing any components, clean around the mounting fasteners and sealing joints with compressed air to remove any loose debris.

External Mounted Crankcase Breather.

NOTE: It may be necessary to remove an engine cover to access the crankcase breather/rocker lever cover. Refer to the OEM instructions.

Disconnect the crankcase breather tube from the crankcase breather assembly.

Disconnect the crankcase breather oil drain line from the crankcase breather assembly.

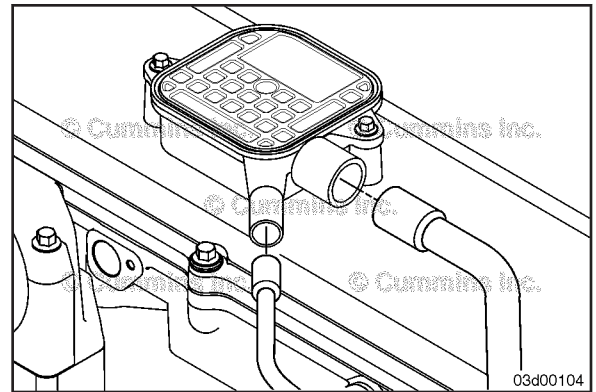

Internal Mounted Crankcase Breather

Disconnect the breather tube connection at the back of the rocker lever cover.

In general, two types of breather tube connections are used at the rocker lever cover:

- 1 A clamping plate and capscrew hold the breather tube connection to the rocker lever cover. Remove the capscrew and clamping plate to disconnect the breather tube connection from the rocker lever cover.
- 2 One or two capscrew(s) directly mount the breather tube connection to the rocker lever cover. Remove the capscrew(s) to disconnect the breather tube connection from the rocker lever cover.

NOTE: Some breather tube connections use internal torx capscrews to secure the breather tube connection to the rocker lever cover.

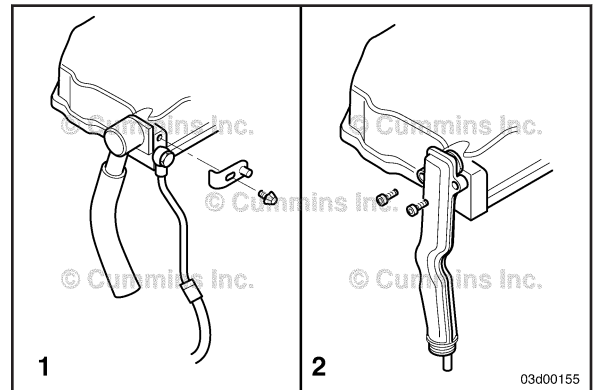

If equipped, at the rear of the rocker lever cover, remove the banjo bolt and sealing washers connecting the breather oil drain line to the rocker lever cover.

NOTE: Not all engines with an internal mounted crankcase breather are equipped with an external breather oil drain line. On some engines the breather oil drain line is internal to the breather connection tube (1).

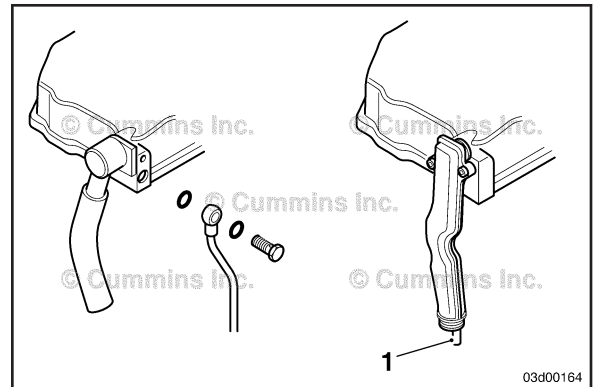

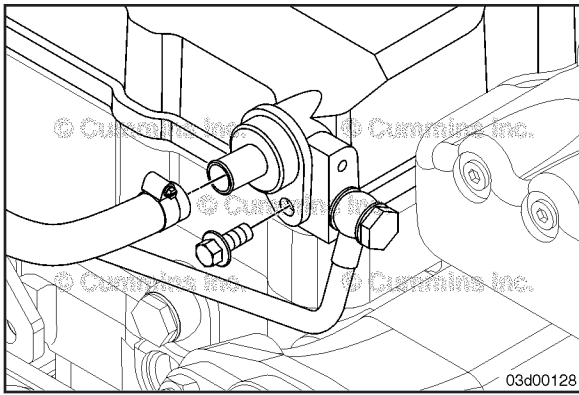

Marine Applications

Open Draft Tube Type

Remove the snap clamp and the crankcase breather tube.
Remove the capscrew and the cover plate.
Remove the banjo bolt and sealing washers connecting the breather oil drain line to the rocker lever cover.

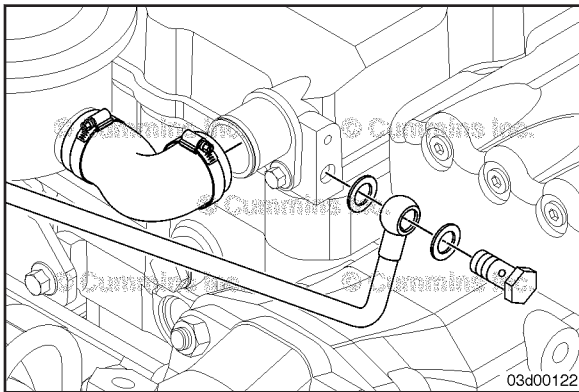

Closed Draft Tube Type

Remove the breather oil drain back tube banjo bolt and sealing washer from the rear of the rocker lever cover.
Loosen and remove the closed crankcase breather system hose from the valve cover breather port.

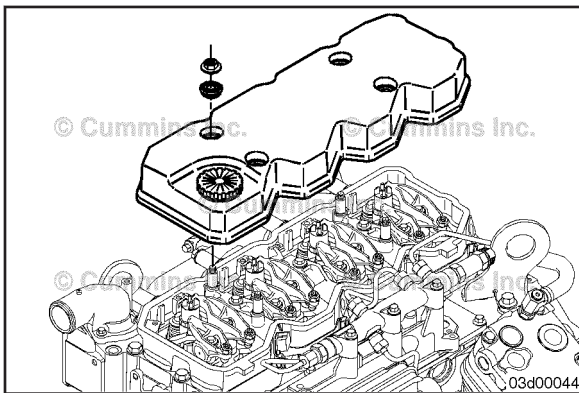

Stud Mounted Rocker Lever Cover.

NOTE: Do **not** remove the rocker lever cover gasket on engines in which the rocker lever cover gasket is fit into a groove at the base of the rocker lever cover. The gasket is reusable. Once the gasket is removed from the rocker lever cover, it **must** be replaced.

Remove the mounting nuts and isolators from the rocker lever cover.

NOTE: If equipped, it may be necessary to gently pry the breather tube connection from the back of the rocker lever cover while removing.

Remove the rocker lever cover.

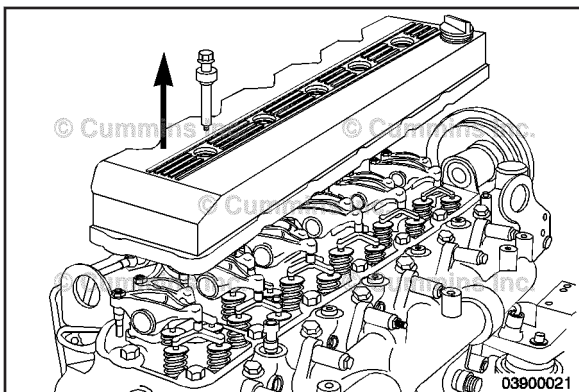

Capscrew Mounted Rocker Lever Cover

NOTE: Do **not** remove the rocker lever cover gasket on engines in which the rocker lever cover gasket is fit into a groove at the base of the rocker lever cover. The gasket is reusable. Once the gasket is removed from the rocker lever cover, it **must** be replaced.

Remove the mounting capscrews and isolators from the rocker lever cover.

NOTE: If equipped, it may be necessary to gently pry the breather tube connection from the back of the rocker lever cover while removing.

Remove the rocker lever cover.

Rocker Lever Housing (003-013)

Remove

Disconnect the injector harness pass-through connector.

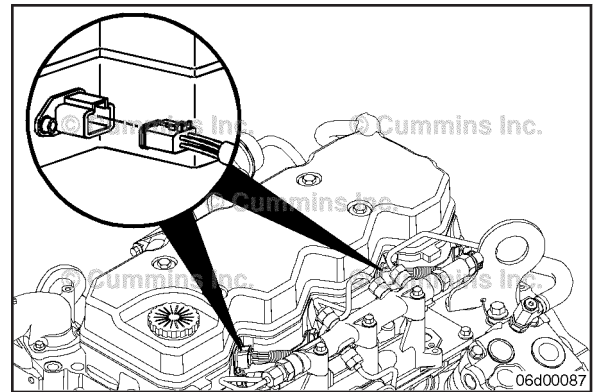

Remove the rocker lever cover. Refer to Procedure 003-011

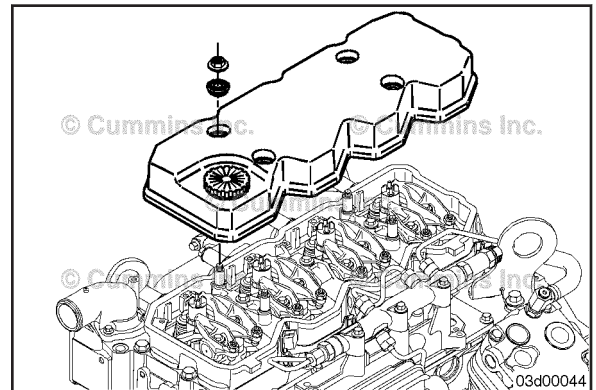

NOTE: It is **not** necessary to mark the injector solenoid wires.

Disconnect the injector wiring from the injector. Refer to Procedure 006-026

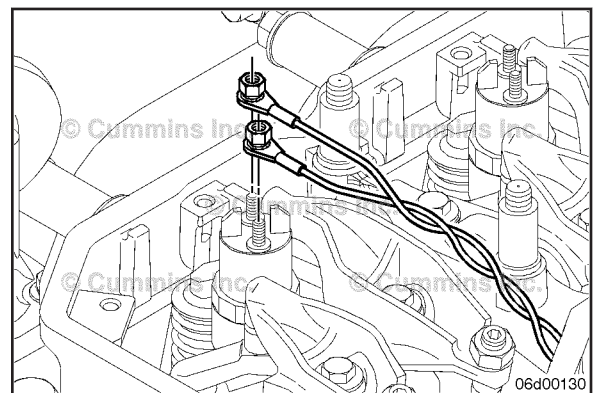

NOTE: Check the gasket while it is installed in the rocker housing. Once the gasket is removed it **must** be replaced.

NOTE: Check for cracks in the rocker housing bridge area before removing the mounting capscrews.

Remove the rocker housing, capscrews, and gasket.

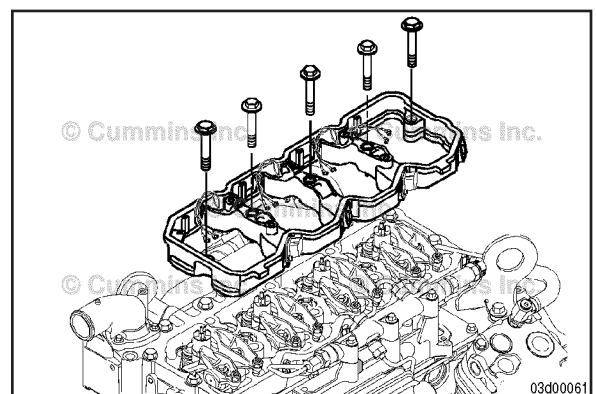

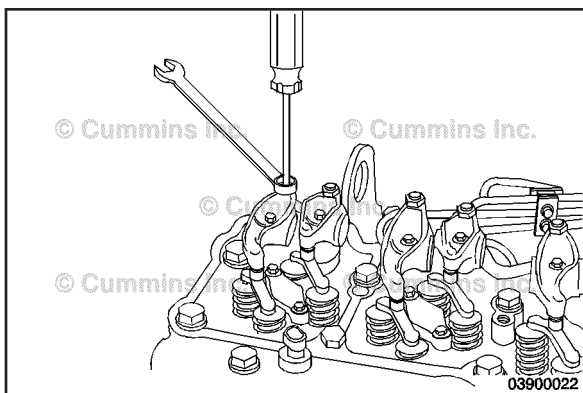

Rocker Lever (003-008)

Remove

Loosen the adjusting screw locknuts.
Loosen the adjusting screws until they stop.

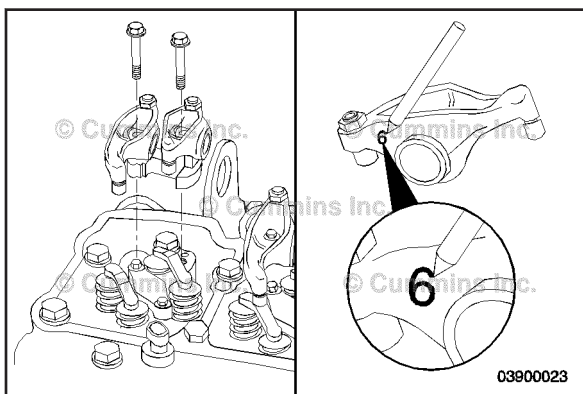

Remove the capscrews from the rocker lever pedestals.
Remove and mark the pedestals and rocker lever assemblies one at a time as to their location and position.
Remove and mark the crossheads one at a time as to their location and position. The crossheads and rocker assembly **must** be installed in their original location and position when reused.

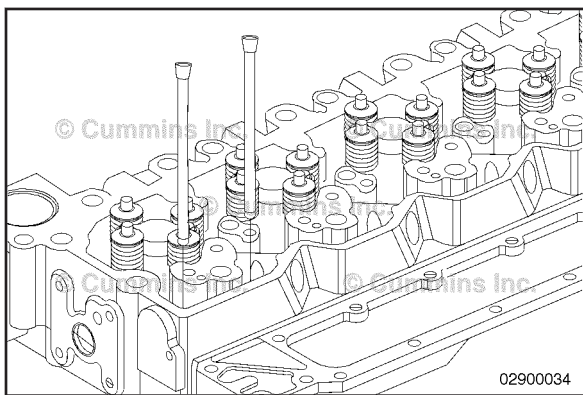

Push Rods or Tubes (004-014)

Remove

Mark the push rods to identify their location.
NOTE: The push rods **must** be installed in their original location and position.
Remove the push rods.

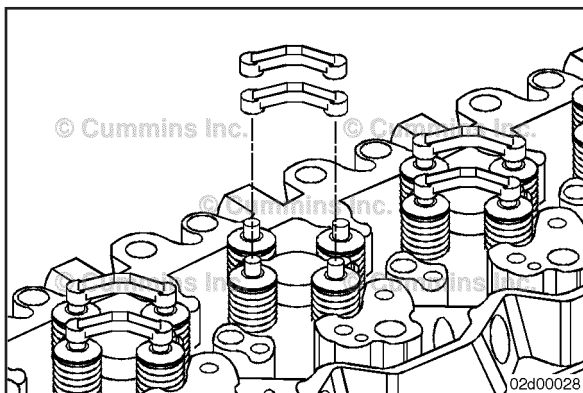

Crosshead (002-001)

Remove

NOTE: Make note of the crosshead location and orientation. If the crossheads are reused, they **must** be installed in their original location and orientation.
Remove the crossheads.

Air Intake Connection Adapter (010-131)



Remove

Remove the v-band clamp, the elbow piece of the air intake connection adapter, and the seal.

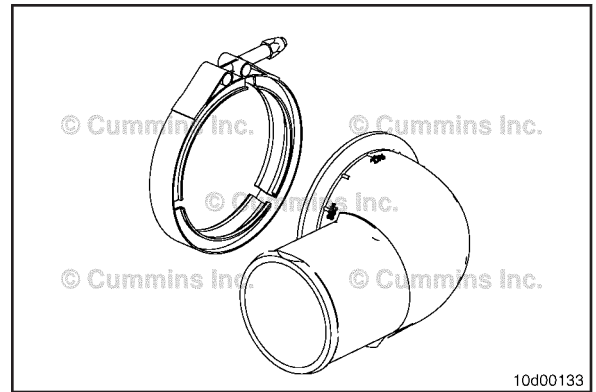

Remove the three capscrews that hold the straight piece of the air intake connection adapter to the air intake connection, and remove the seal.



NOTE: On engines equipped with air compressors, remove the air compressor intake line from the adapter.

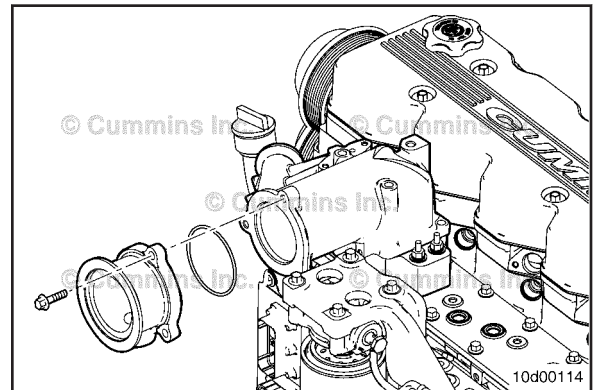

Service Tip: On engines equipped with EGR, the air intake connection adapter holds the EGR mixer in place.

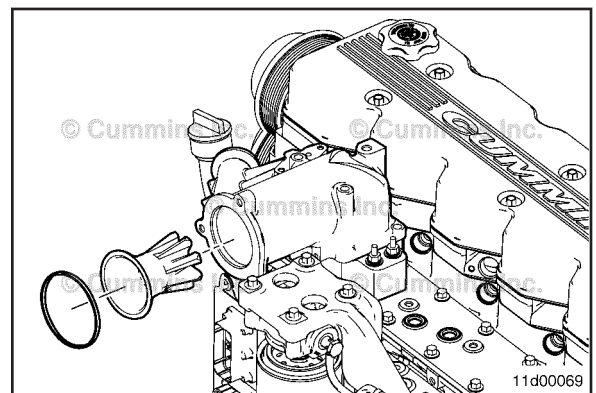

Remove the v-band clamp, seal, and air intake connection adapter.



Remove the air compressor intake line from the adapter (if applicable).

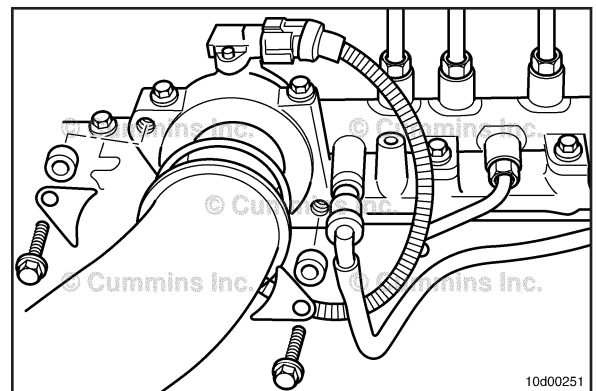

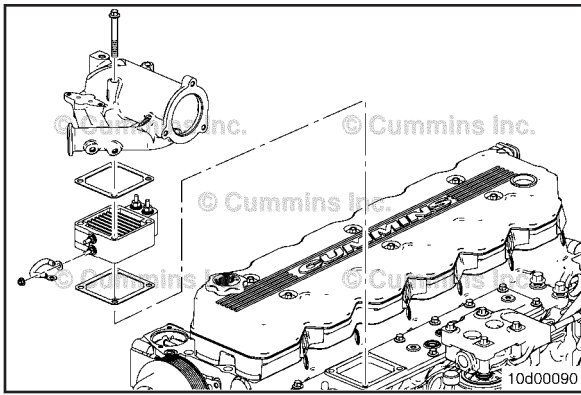

Air Intake Connection (010-080)

Remove

Automotive and Industrial

Remove the mounting capscrews, air intake connection, top gasket, cold starting aid, and bottom gasket.

NOTE: Some air intake connections may **not** have an EGR connection as shown.

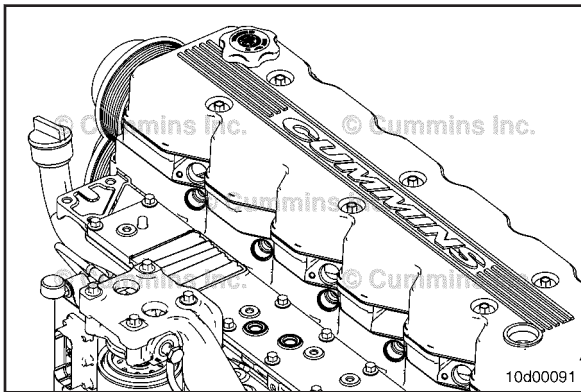

NOTE: Be sure **not** to tape over all manifold edges so the mounting surfaces can be properly cleaned.

Tape off the intake manifold cover opening or place a clean rag in the intake to prevent debris from entering the intake system.

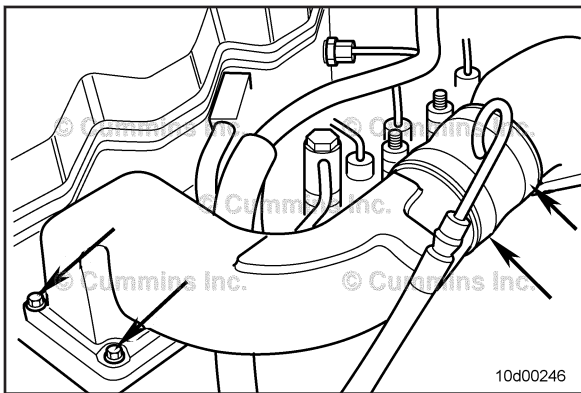

Marine Applications

Remove the four mounting capscrews at the intake manifold.

Loosen the hose clamps.

Remove the front portion of the connection.

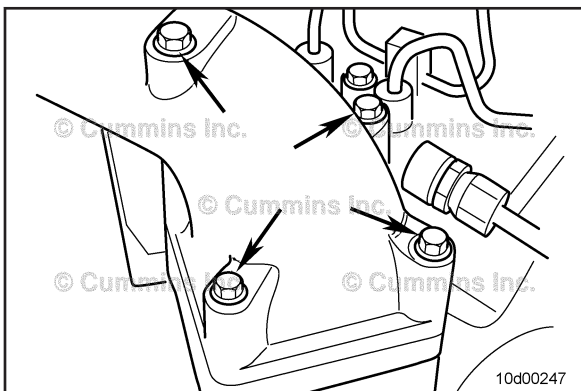

Remove the four mounting capscrews at the aftercooler assembly.

Remove the rear portion of the connection.

Injector Supply Lines (High Pressure) (006-051)



Remove



NOTE: For removal and installation of the fuel pump to rail high-pressure line. Refer to Procedure Procedure 005-016 in Section 5.

Remove the injector supply line brace cap screws. Do **not** remove braces and isolators from fuel line.

NOTE: It may be necessary to remove the air intake connection to remove all of the injector supply lines. Refer to Procedure Procedure 010-080 in Section 10.

Disconnect the injector supply lines from the high-pressure fuel connectors and from the fuel rail.

Remove the injector supply lines.

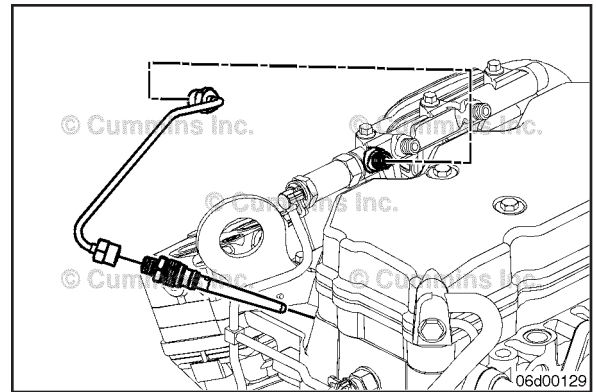

Fuel Rail (006-060)

Remove



NOTE: Do **not** remove the fuel rail pressure sensor unless it is being replaced. The fuel pressure sensor **must** be replaced if it is removed from the fuel rail.

Disconnect the fuel pressure wiring harness sensor connector.

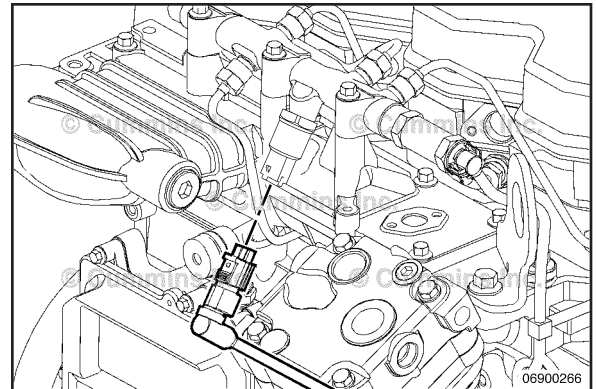

▲ WARNING ▲

Depending on the circumstance, diesel fuel is flammable. When inspecting or performing service or repairs on the fuel system, to reduce the possibility of fire and resulting severe personal injury, death or property damage, never smoke or allow sparks or flames (such as pilot lights, electrical switches, or welding equipment) in the work area.

NOTE: The fuel rail pressure relief valve drain line can have either a banjo fitting or a quick-disconnect fitting.

Disconnect the fuel pressure relief valve drain line.

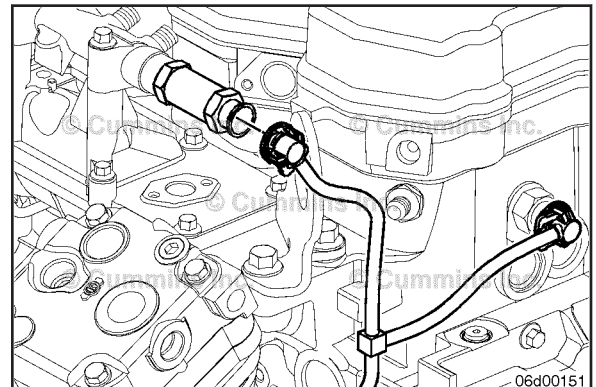

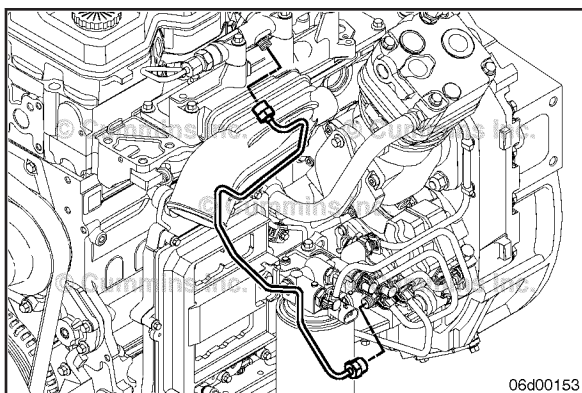

NOTE: It is **not** necessary to remove the high-pressure supply line from the engine.



Disconnect the high-pressure supply line that connects the fuel pump to the fuel rail.

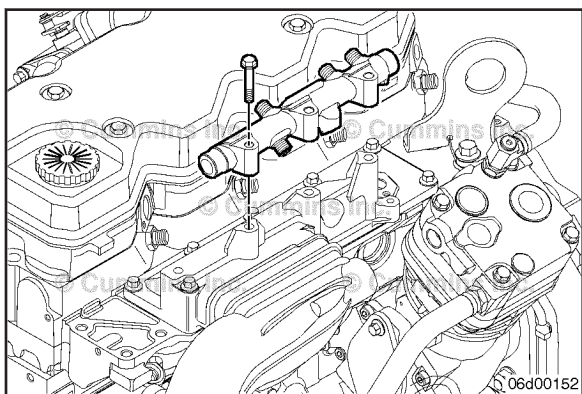

NOTE: For some engines, it could be necessary to loosen the three cap screws holding the fuel filter bracket in place. This will provide adequate clearance to separate the high-pressure supply line from the fuel rail.

Remove the capscrews and the fuel rail.

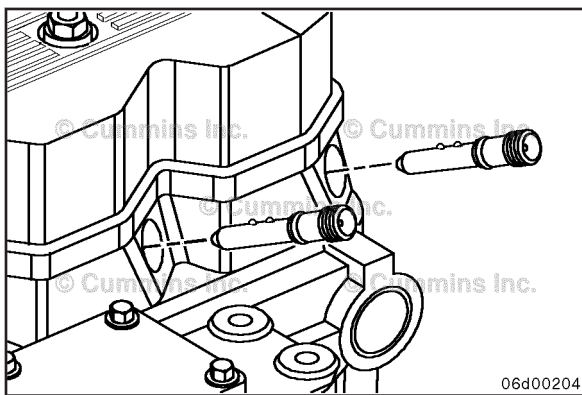

Fuel Connector (Head Mounted) (006-052)



Remove

Remove the fuel connector retaining nut.



Install the fuel connector remover, Part Number 3164025.

NOTE: When removing the fuel connector from the cylinder head, care **must** be taken to make sure the connector o-ring is **not** damaged.

Remove the fuel connector from the cylinder head.

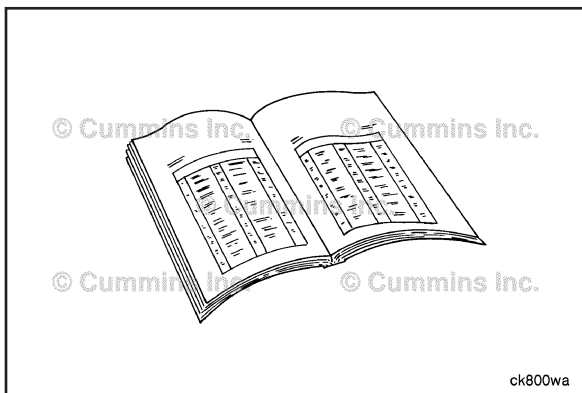

Finishing Steps



▲ WARNING ▲

Make sure the fuel inlet and return valves are returned to the open position before cranking engine. Engine damage can result if valves are in the wrong position when engine is cranked or started. Environmental damage can also occur. Refer to Procedure 006-999 in Section F.



- Install the high-pressure injector supply line. Refer to Procedure 006-051 in Section 6.
- For marine applications, **open** the fuel supply and return valves.
- Operate the engine and check for leaks.

Fuel Drain Lines (006-013)

Remove

NOTE: Mark the location of all p-clips, and routing of fuel drain lines, to ensure that they are replaced in the correct location during reassembly.

Remove all capscrews from the fuel drainline.

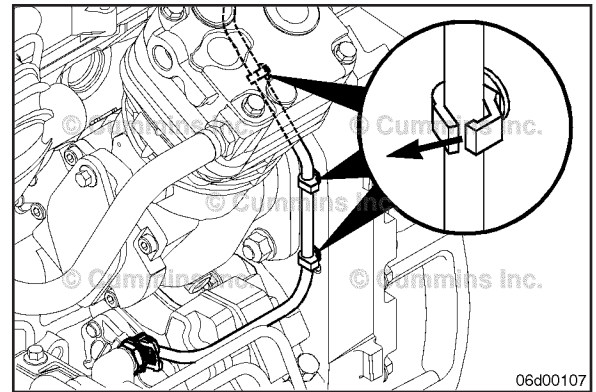

Remove the fuel drain line from the fuel rail pressure relief valve.

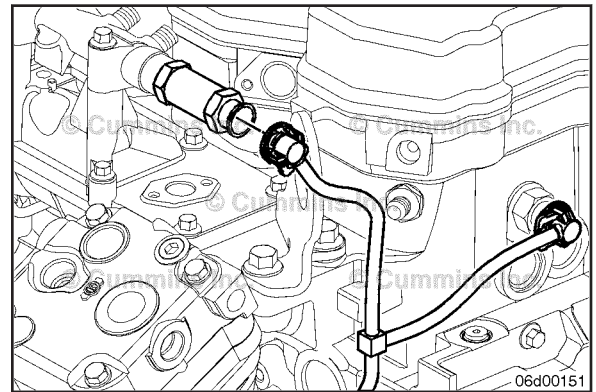

Remove the fuel drain line from the injector drain port at the back of the cylinder head.

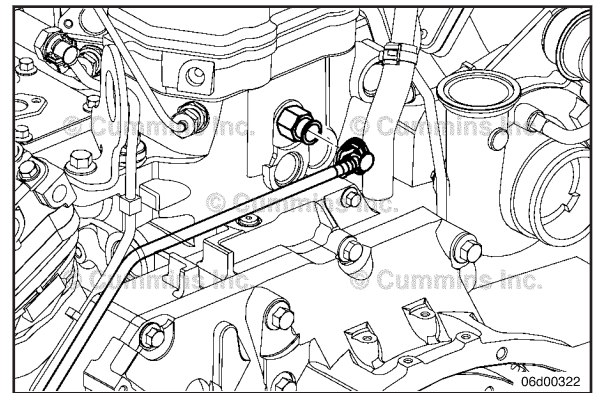

Remove the fuel drain line from the fuel injector pump.

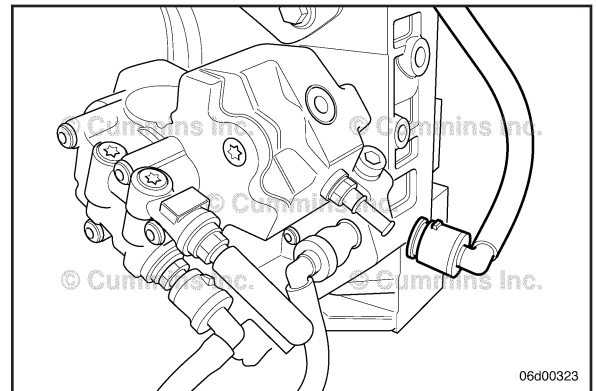

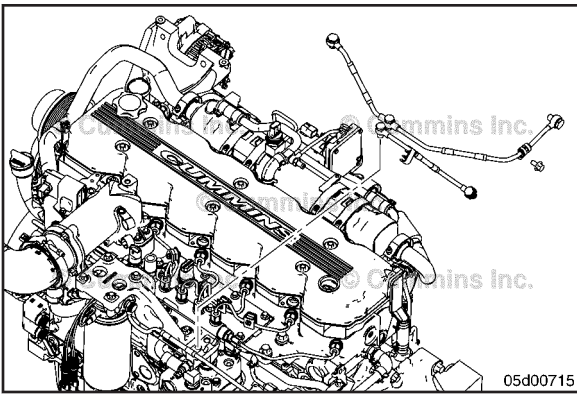

Remove the fuel drain line from the fuel return manifold.

NOTE: For marine applications, each of the drain lines individually connect to the fuel return manifold.

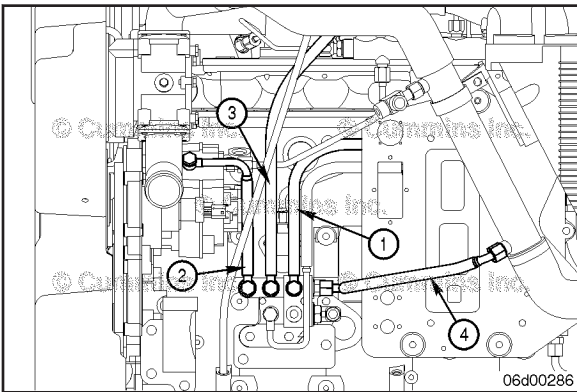

⚠ WARNING ⚠

Fuel is flammable. Keep all cigarettes, flames, pilot lights, arcing equipment, and switches out of the work area and areas sharing ventilation to reduce the possibility of severe personal injury or death when working on the fuel system.

⚠ CAUTION ⚠

Use caution when disconnecting or removing fuel lines, replacing filters and priming the fuel system that fuel is not spilled or drained into the bilge area. Do not drop or throw filter elements into the bilge area. The fuel and fuel filters must be discarded in accordance with local environmental regulations.

⚠ CAUTION ⚠

Clean all fittings before disassembly. Dirt or contaminants can damage the fuel system.

Marine applications have four fuel drain lines as follows:

- 1 From the injector return port in the cylinder head to the combined fuel manifold
- 2 From the high-pressure fuel pump to the combined fuel manifold
- 3 From the fuel pressure relief valve to the combined fuel manifold
- 4 From the combined fuel manifold to the fuel cooler.

Shut off the fuel supply and return valves. Remove the banjo bolts, fittings, clips, and fuel drain lines.

Fuel Supply Lines (006-024)

Remove

NOTE: Mark the location of all p-clips and routing of fuel supply lines to ensure that they are replaced in the correct location during reassembly.

NOTE: Engines with a fuel cooled ECM cooling plate will have a fuel supply line connecting the ECM cooling plate to the inlet of the gear pump.

Remove the fuel supply line connecting the ECM cooling plate to the inlet of the gear pump, if applicable.

Remove the fuel supply line connecting the gear pump to the fuel filter head.

NOTE: Fuel filter may be remote mounted off of the engine.

Remove the fuel supply line connecting the fuel filter head to the inlet to the high pressure fuel pump.

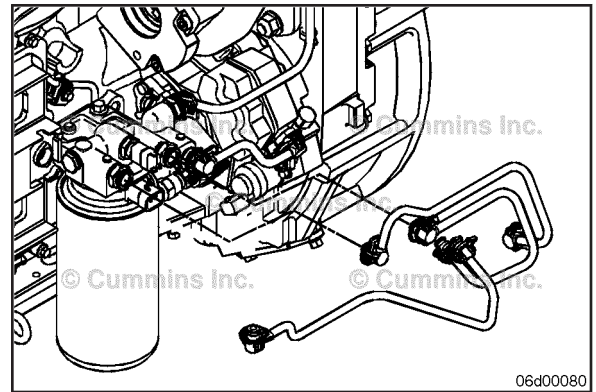

NOTE: Mark the location of all p-clips and routing of fuel supply lines to ensure that they are replaced in the correct location during reassembly.

For marine applications, **shut off** fuel supply and return valves.

NOTE: For marine applications, a fuel supply line connects the fuel supply manifold to the inlet of the electric lift pump.

Remove the fuel supply line connecting the fuel supply manifold to the inlet of the electric lift pump, if applicable.

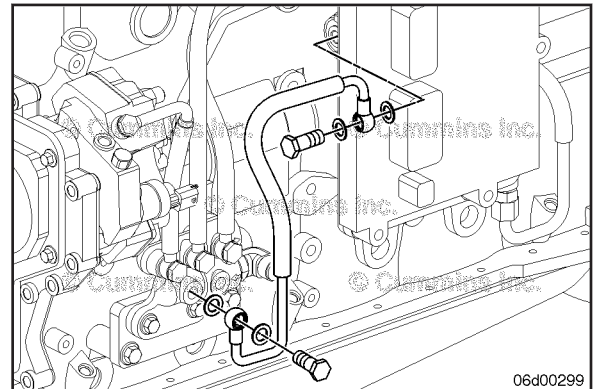

NOTE: For engines equipped with a fuel cooled ECM cooling plate, there is a fuel supply line connecting the ECM cooling plate to the electric fuel lift pump.

Remove the fuel supply line connecting the ECM cooling plate to the electric fuel lift pump, if applicable.

Remove the fuel supply line connecting the electric fuel lift pump, to the fuel filter inlet, if applicable.

NOTE: For marine applications, a fuel supply line connects the fuel cooled ECM cooling plate to the inlet of the fuel filter head.

Remove the fuel supply line connecting the fuel cooled ECM cooling plate to the inlet of the fuel filter head, if applicable.

NOTE: The fuel filter may be remote mounted off of the engine.

Remove the fuel supply line connecting the fuel filter outlet to the gear pump inlet.

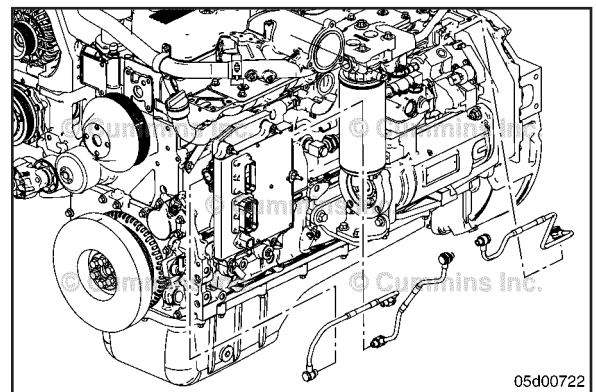

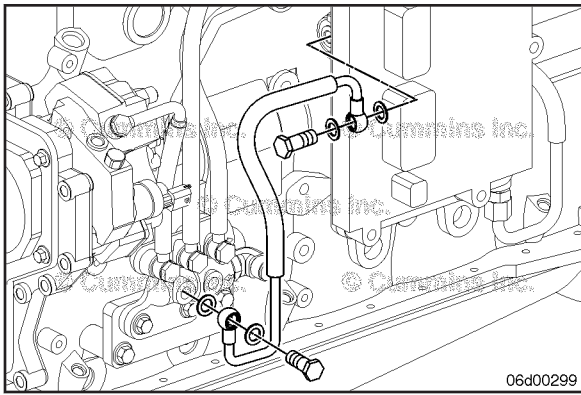

▲WARNING▲

Fuel is flammable. Keep all cigarettes, flames, pilot lights, arcing equipment, and switches out of the work area and areas sharing ventilation to reduce the possibility of severe personal injury or death when working on the fuel system.

▲CAUTION▲

Use caution when disconnecting or removing fuel lines, replacing filters and priming the fuel system that fuel is not spilled or drained into the bilge area. Do not drop or throw filter elements into the bilge area. The fuel and fuel filters must be discarded in accordance with local environmental regulations.

Disconnect the fuel line from the combined fuel manifold and the fuel lift pump.

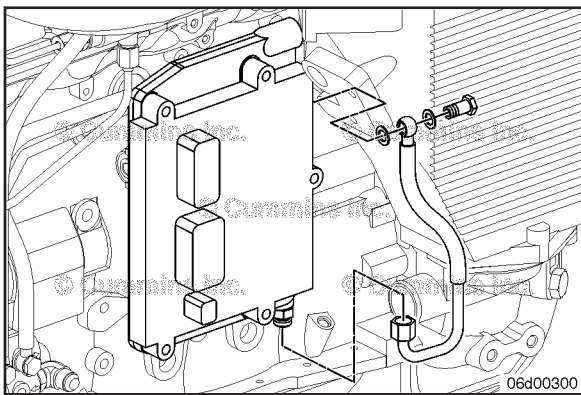

Disconnect the fuel line from the fuel lift pump to the ECM cooling plate.

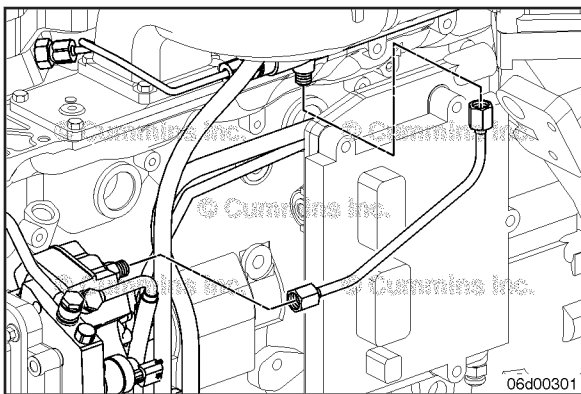

Disconnect the fuel line from the high pressure fuel pump to the fuel rail.

Disconnect the fuel line from the fuel filter to the high pressure fuel pump.

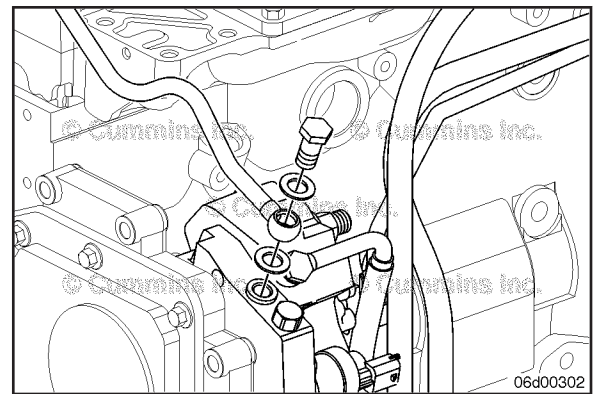

NOTE: Identify the location(s) where the p-clip(s) are located on the fuel line for correct installation of the fuel line.

Disconnect the fuel line from the ECM cooling plate to the fuel filter.

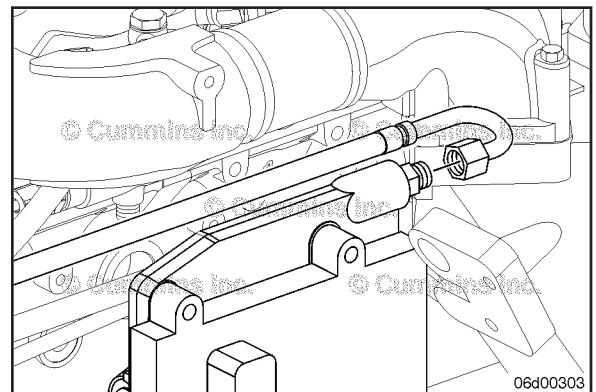

Fuel Filter (Spin-On Type) (006-015) Remove

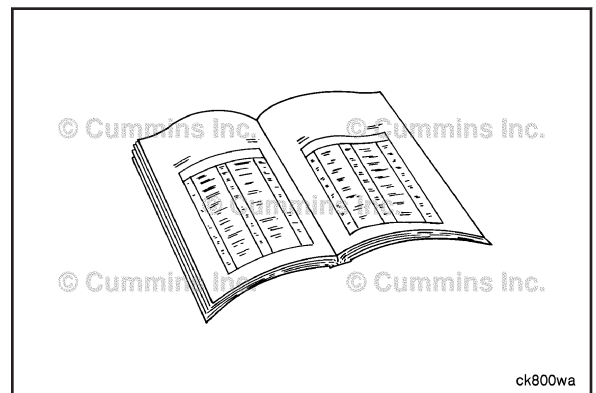

⚠ WARNING ⚠
Fuel is flammable. Keep all cigarettes, flames, pilot lights, arcing equipment, and switches out of the work area and areas sharing ventilation to reduce the possibility of severe personal injury or death when working on the fuel system.

Loosen and remove the fuel filter.

Make sure the seal ring does **not** stick to the fuel filter head.

Remove the ring with an o-ring pick, if necessary.

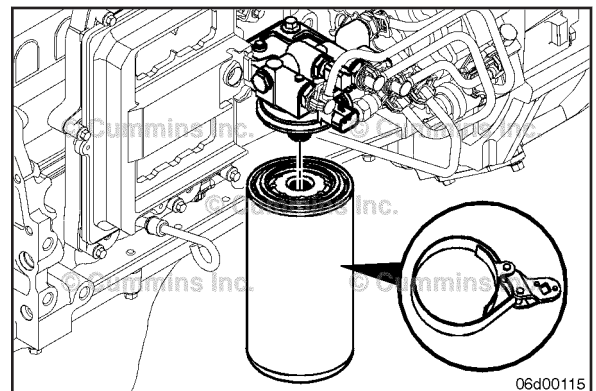

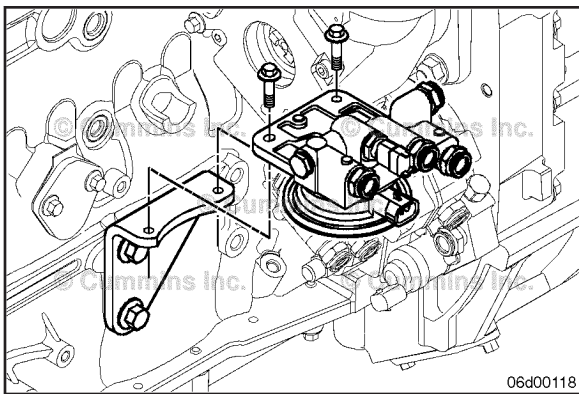

Fuel Filter Head (006-017)

Remove

Low Mount Fuel Filter

NOTE: The fuel filter head and fuel filter head bracket may be one piece.

Remove the fuel filter head bracket capscrews.

Remove the fuel filter head.

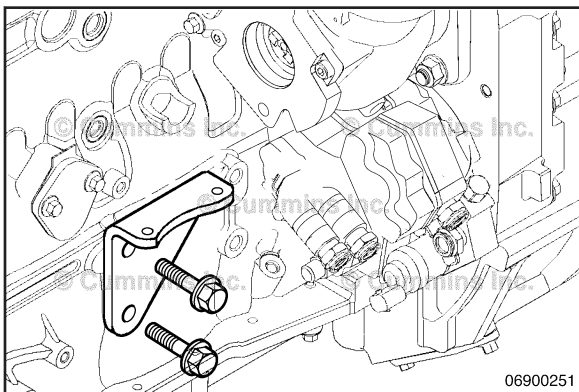

Remove the capscrews holding the fuel filter head bracket in place.

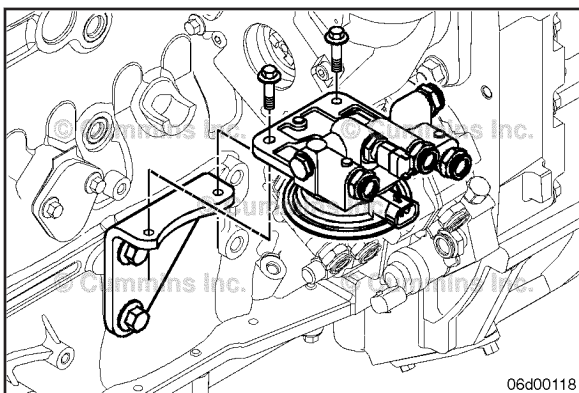

High Mount Fuel Filter

NOTE: The fuel filter head and fuel filter head bracket may be one piece.

Remove the fuel filter head bracket capscrews.

Remove the fuel filter head.

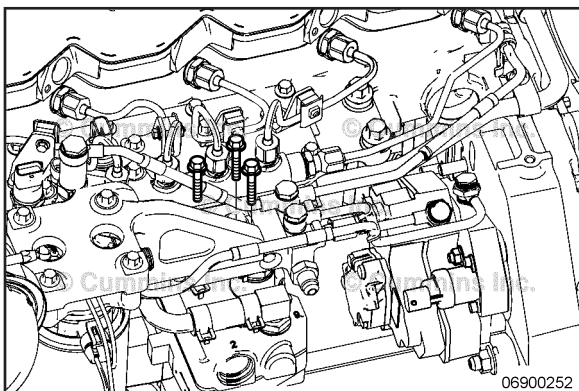

Remove the capscrews holding the fuel filter head bracket in place.

Marine Applications

NOTE: The filter head is marked with an IN and OUT for the line connections. Be sure to note the direction of the markings as the filter head is removed to be sure the filter head is **not** installed backwards and the lines are not connected in reverse during installation.

Remove the four mounting capscrews and the fuel filter head.

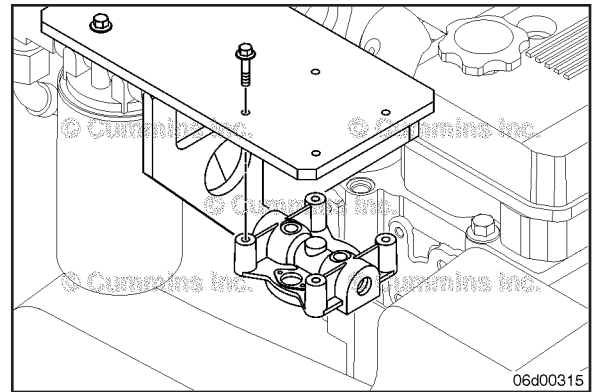

Air Intake Manifold (010-023)

Remove

NOTE: Keep the gasket material, and any other material out of the air intake.

Remove the six capscrews that hold the upper part of the intake manifold to the lower part.

⚠CAUTION⚠

There is a captive capscrew (1) in this manifold, the captive capscrew must be removed after the other five capscrews have been removed, to prevent damage to the intake manifold.

Remove the lower part of the intake manifold.

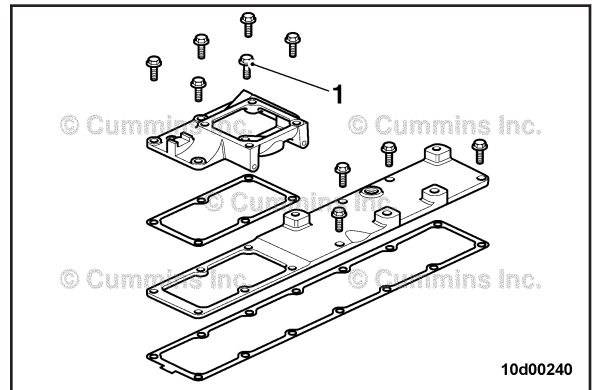

If the air intake manifold will be off for a prolonged period of time, tape off the intake manifold opening to prevent debris from entering the intake system.

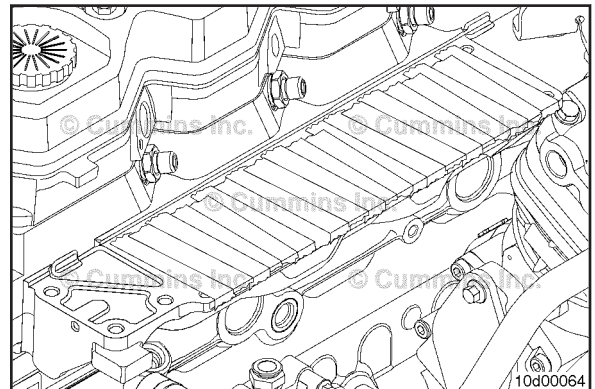

NOTE: Keep the gasket material, and any other material out of the air intake.

Remove the air intake manifold capscrews and remove the air intake manifold.

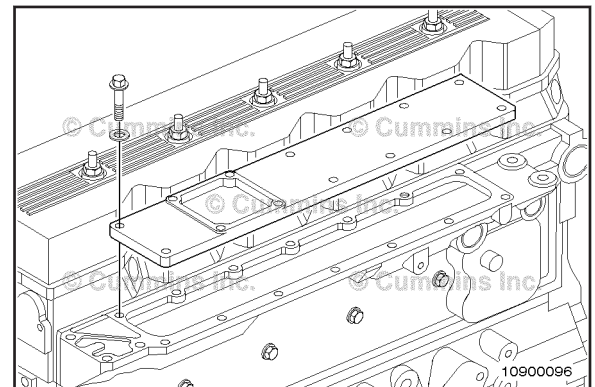

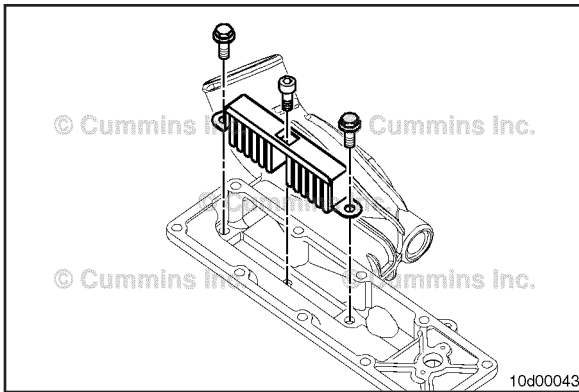

If the engine has an integral cold-starting aid, remove it. Refer to Procedure 010-029

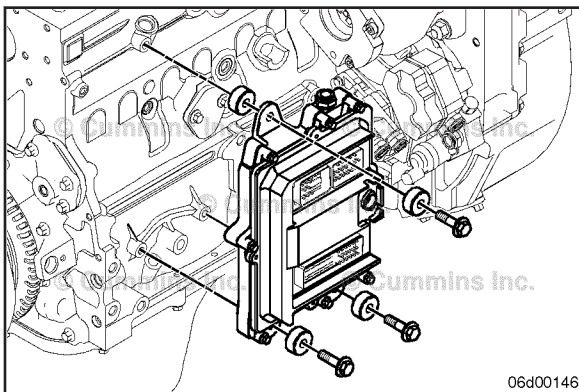

ECM Cooling Plate, Fuel Cooled (006-006)

Remove

Remove the ECM and cooling plate mounting capscrews.
Do **not** lose any of the heat-resistant grommets.
Remove the ECM and cooling plate from the engine.
Drain any remaining fuel into the fuel can.

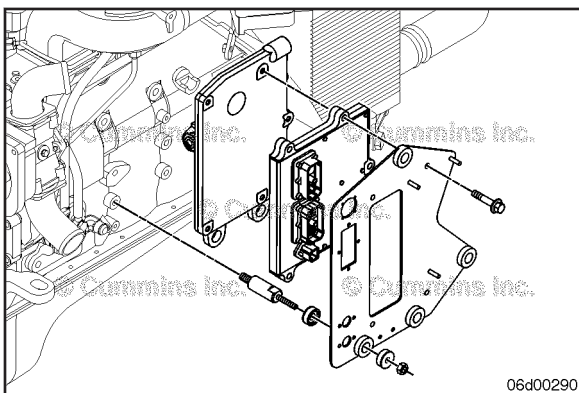

NOTE: The ECM cooling plate, ECM, and ECM mounting bracket are removed and installed as an assembly.

NOTE: The ECM mounting bracket has three mounting studs at the bottom of the bracket and one capscrew at the top. Remove the top mounting capscrew last.

Remove the three bottom ECM bracket mounting nuts and grommets.

Remove the top capscrew and the ECM mounting bracket, ECM, and fuel cooled ECM cooling plate.

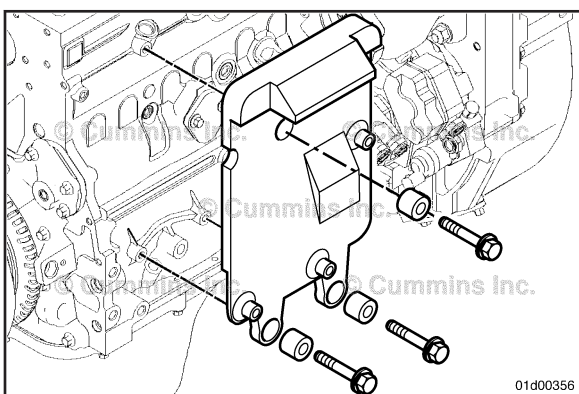

ECM Mounting Plate (001-103)

Remove

Remove the three cap screws holding the ECM mounting plate to the cylinder block.

NOTE: Do **not** lose the vibration isolators while removing the cap screws.

NOTE: On engines with an aluminum ECM mounting plate, the steel yolk and ECM mounting plate are removed as an assembly.

Fuel Lift Pump (005-045)

Remove

Thoroughly clean the fittings and components before removal.

NOTE: Make sure that debris, water, steam, or cleaning solution does **not** reach inside the fuel system.

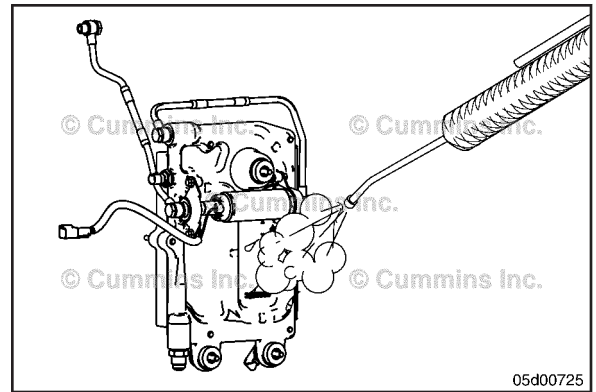

Remove the fuel lift pump inlet and outlet fuel lines.
Disconnect the fuel lift pump wiring harness connector.

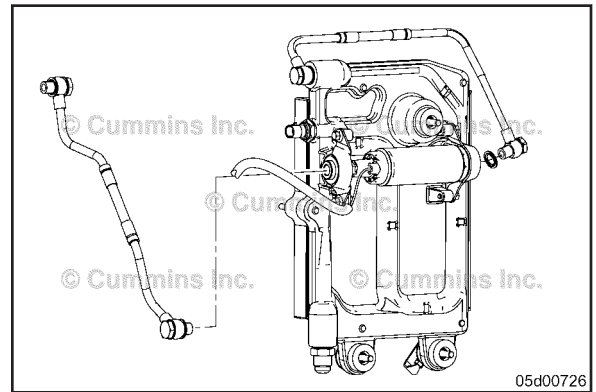

Remove the fasteners holding the lift pump to the back of the ECM cooler plate.

Remove the fuel lift pump.

NOTE: For most automotive applications, the lift pump can be removed without having to remove the ECM and ECM mounting plate.

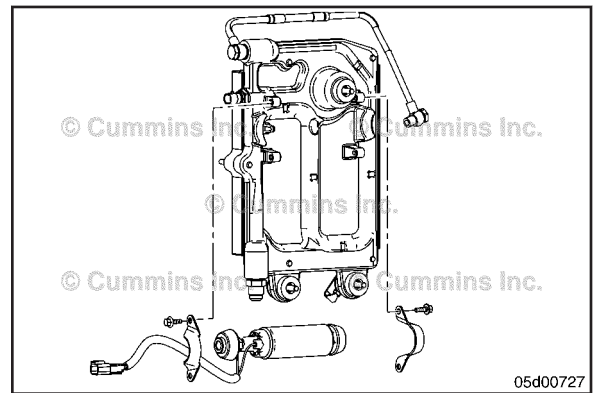

For 24-volt systems with voltage regulators, remove the voltage regulator from the bottom edge of the ECM by removing the lower two ECM mounting capscrews. The relay is fastened to the wiring harness near the ECM connectors.

Disconnect the voltage regulator wiring harness connectors and remove the voltage regulator assembly.

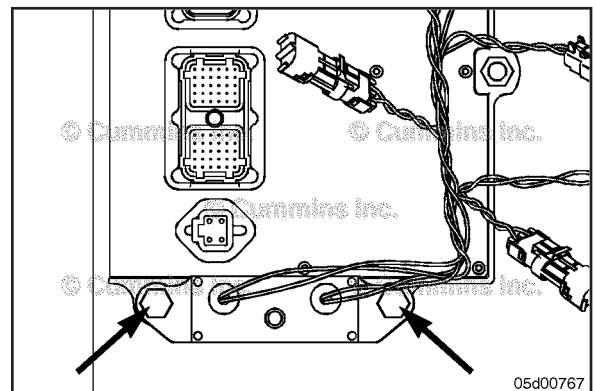



Fuel Pump (005-016)

Remove

NOTE: A counter-torque **must** be applied to the fitting on the high-pressure pump. This is to prevent the fitting from being loosened and to prevent the possibility of a leak.

Disconnect the high-pressure supply line from THE high-pressure fuel pump to the fuel rail and loosen the holding brackets.

Disconnect the EFC actuator valve wire harness connector.

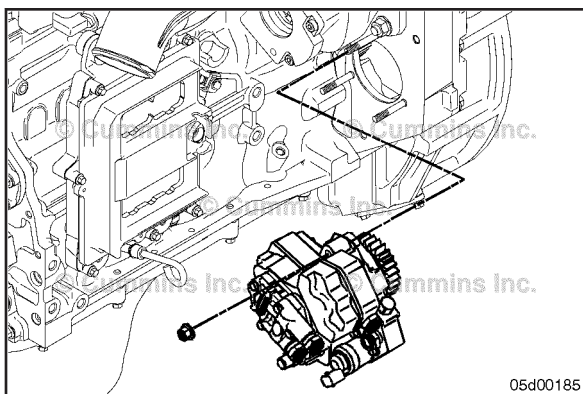

Rear Gear Train

Remove the three flanged fuel pump mounting nuts.

Remove the fuel pump from the gear housing.

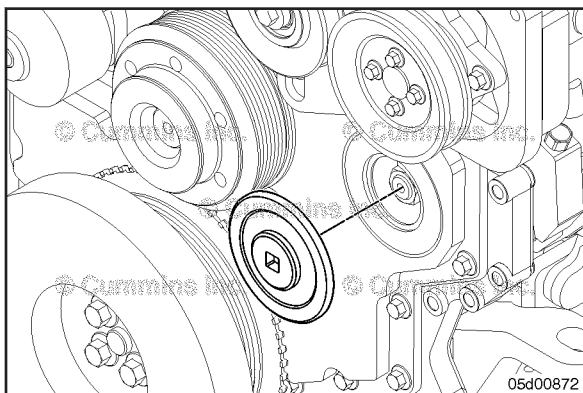

Front Gear Train

Remove the fuel pump drive access cover with a 3/8-inch drive ratchet.

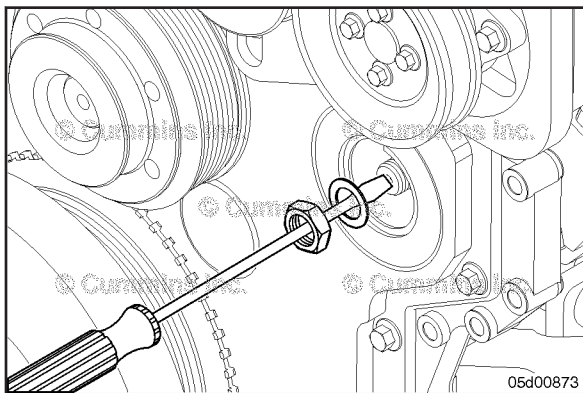

⚠CAUTION⚠

Place a clean cloth in the air-gap between the fuel pump drive gear and the gear cover, or use a screwdriver to prevent the mounting nut and lock washer from being dropped into the front gear train.

⚠CAUTION⚠

The fuel pump drive gear is captive between the gear housing and the gear cover. Do not rotate the engine while the gear is not supported by the fuel pump drive shaft. The gear, gear housing, or gear cover can be damaged.

Remove the fuel pump drive gear retaining nut and lock washer.

⚠ CAUTION ⚠

Protect the fuel pump drive shaft threads from damage during gear removal.

Install the fuel pump drive gear puller onto the drive shaft and gear.

Hold the gear puller while removing the fuel pump drive gear.

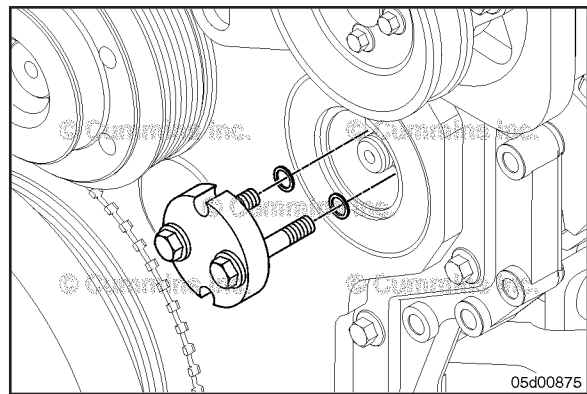

Remove the fuel pump assembly.

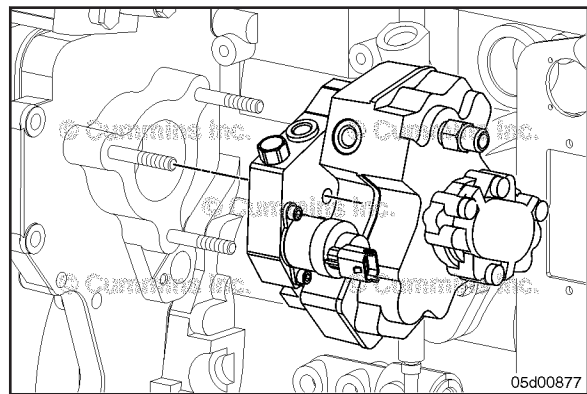

Marine Applications

Remove the three fuel pump flanged mounting nuts.

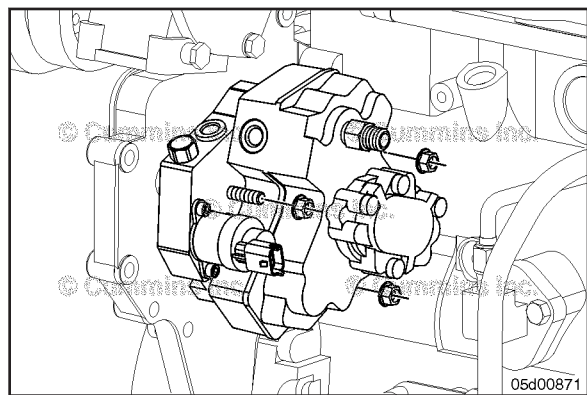

Remove the fuel pump drive access cover with a 3/8-inch drive ratchet.

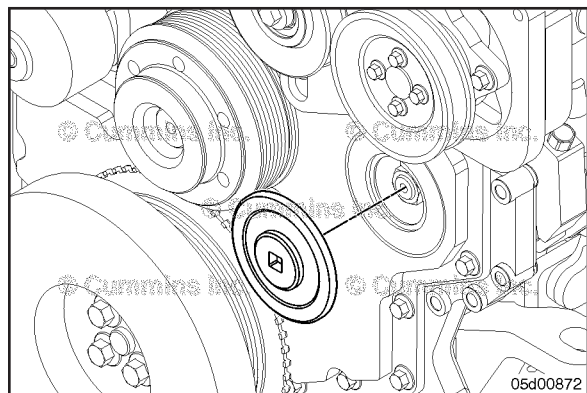

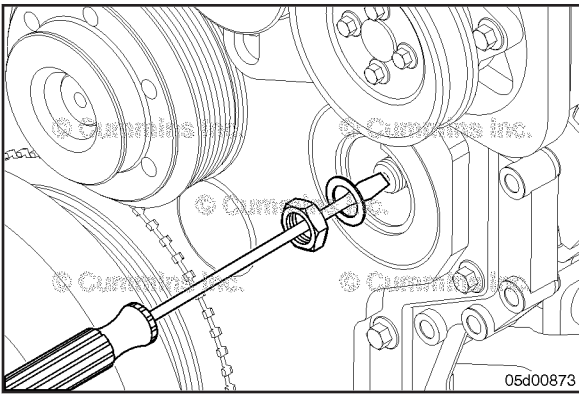

⚠ CAUTION ⚠

Place a clean cloth in the air gap between the fuel pump drive gear and the gear cover, or use a screw driver to prevent the mounting nut and lock washer from being dropped into the front gear train.

⚠ CAUTION ⚠

The fuel pump drive gear is captive between the gear housing and the gear cover. Do not rotate the crankshaft while the gear is not supported by the fuel pump drive shaft. The gear, gear housing, or gear cover can be damaged.

Remove the fuel pump drive gear retaining nut and lock washer.

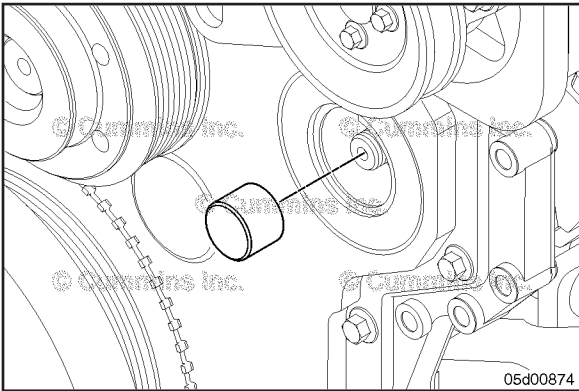

Install the spacer, Part Number 4918317, from service tool, Part Number 3163381, onto the fuel pump drive shaft.

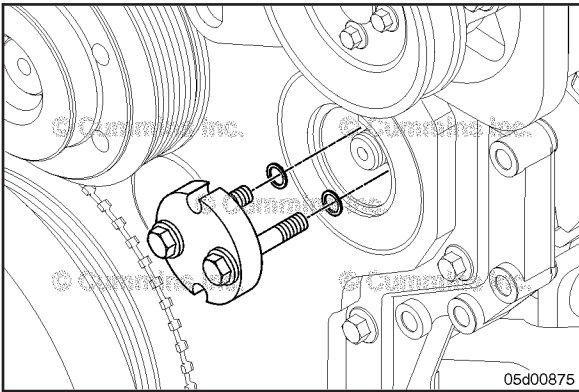

⚠ CAUTION ⚠

Protect the fuel pump drive shaft threads from damage while removing the fuel pump gear.

Install the fuel pump drive gear puller, Part Number 3163381, onto the fuel pump drive shaft and gear.

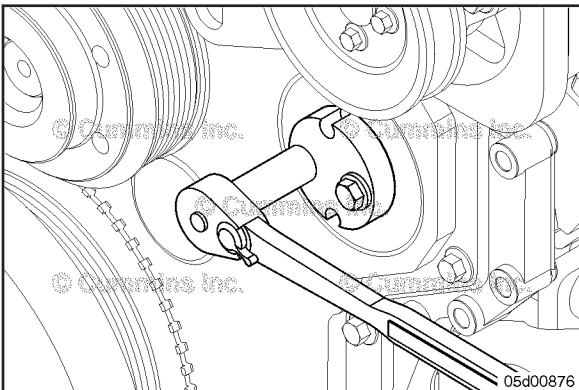

Use a ratchet and remove the fuel pump drive gear from the fuel pump drive shaft.

Remove the spacer, Part Number 4918317, from the fuel pump drive shaft.

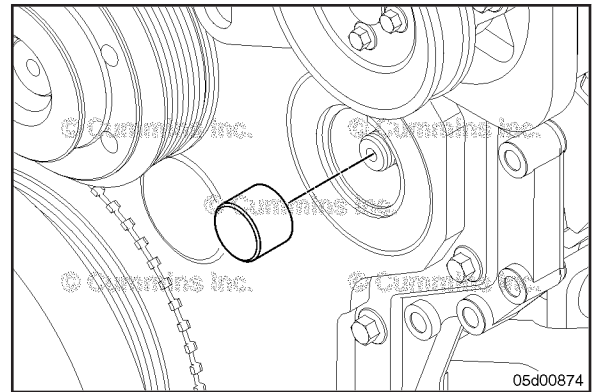

Remove the fuel pump assembly.

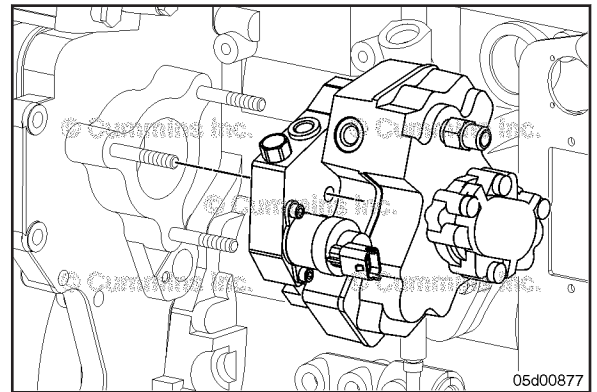

Lubricating Oil Filter (Spin-On) (007-013)

Remove

Clean the area around the lubricating oil filter head.

Use the oil filter wrench, Part Number 3400158, to remove the filter.

Clean the sealing surface of the filter head.

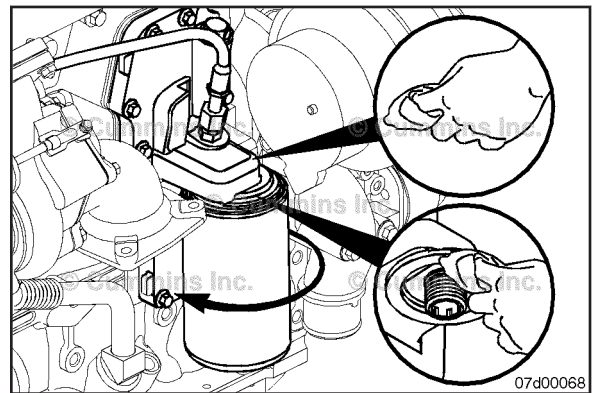

Turbocharger Oil Supply Line (010-046)

Remove

Remove the oil supply line from the oil filter head (1).

Remove the oil supply line from the turbocharger bearing housing (2).

NOTE: Use a wrench to hold the fitting at the oil filter head (1) while loosening the oil supply line fitting. This will help prevent the filter head fitting from accidental loosening.

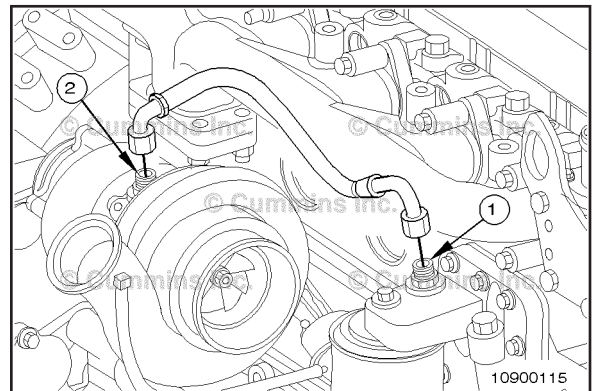

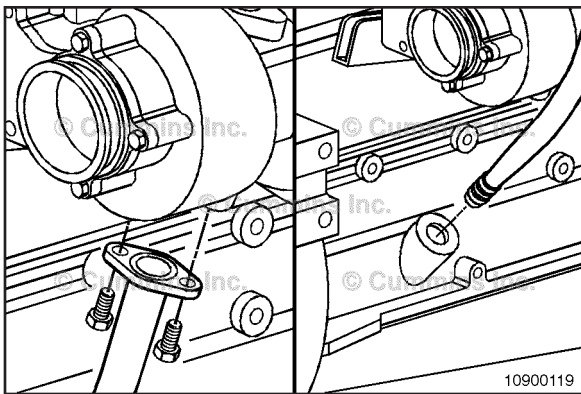

Turbocharger Oil Drain Line (010-045)

Remove

NOTE: Marine applications use a hose connection at the cylinder block end of the drain tube. An additional oil drain fitting is mounted in the cylinder block and seals with an o-ring.

Remove the capscrews from the turbocharger oil drain tube.

Remove the hose clamps from the drain boss, if applicable.

Pull the drain line out of the drain line boss.

Pull the turbocharger oil drain line connection out of the cylinder block.

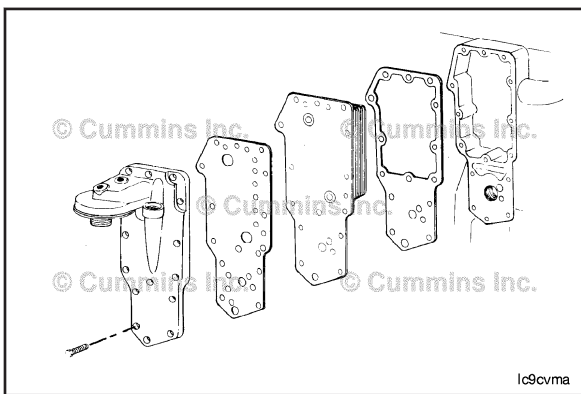

Lubricating Oil Cooler (007-003)

Remove

Remove the lubricating oil cooler housing capscrews, housing, gaskets, and cooler element.

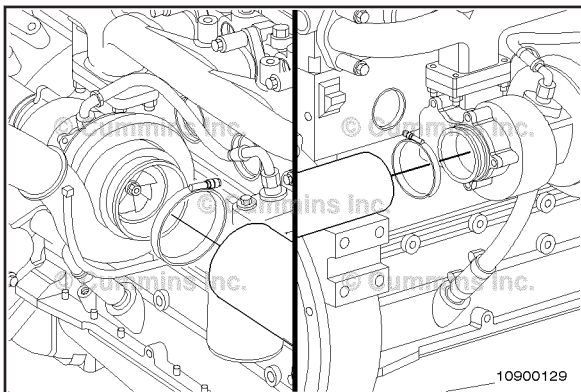

Turbocharger (010-033)

Remove

Automotive and Industrial

- Remove the exhaust piping.
- Remove the turbocharger compressor air inlet connection. Refer to Procedure 010-022 in Section 10.

▲WARNING▲

This component or assembly weighs greater than 23 kg [50 lb]. To prevent serious personal injury, be sure to have assistance or use appropriate lifting equipment to lift this component or assembly.

▲WARNING▲

- Remove the turbocharger compressor outlet elbow, v-band clamp, and o-ring from the turbocharger compressor outlet.

▲CAUTION▲

Before discarding the turbocharger mounting gasket, identify the type of gasket removed. Some turbocharger mounting gaskets have a divider down the middle of the gasket and some do not. Only replace the gasket with a like gasket. Use of the incorrect gasket will result in turbocharger damage.

- Remove the four turbocharger mounting nuts.
- Remove the turbocharger and gasket.
- **Never** reuse a turbocharger mounting gasket.

Marine Applications

▲WARNING▲

This component or assembly weighs greater than 23 kg [50 lb]. To prevent serious personal injury, be sure to have assistance or use appropriate lifting equipment to lift this component or assembly.

▲CAUTION▲

The gasket water ports are larger on the top and bottom passages. The gasket is also marked "Turbocharger" on the side facing the turbocharger. The gasket must be installed with the port size matching the ports of the exhaust manifold and turbocharger, and with the "Turbocharger" marking facing the turbocharger to prevent damage to the turbocharger from overheating.

- Remove the turbocharger mounting nuts and turbocharger.
- Remove the gasket.

Exhaust Manifold, Dry (011-007)

Remove

Remove the exhaust manifold mounting capscrews, lock plates, and spacers.

Remove the exhaust manifold and gaskets.

Discard the exhaust manifold gaskets. They are **not** reusable.

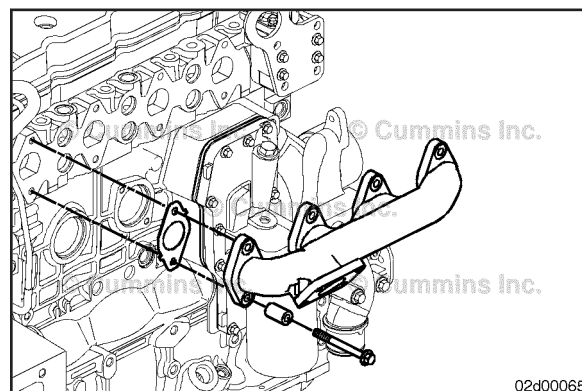
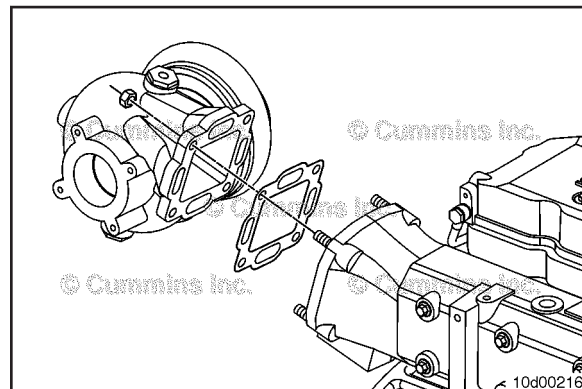
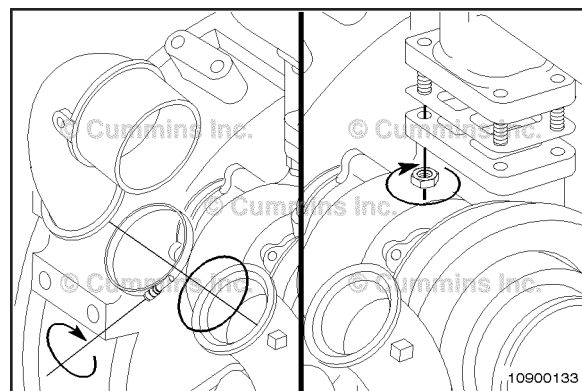

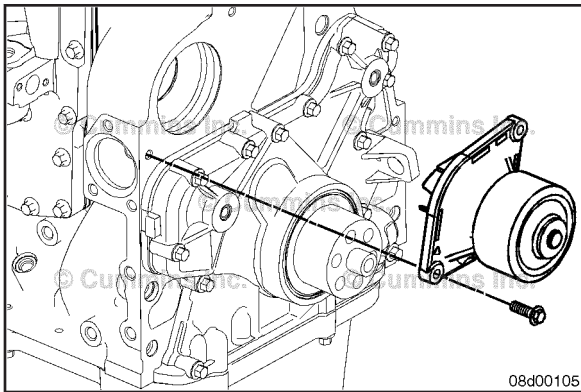

Water Pump (008-062)

Remove

Remove the water pump mounting capscrews.
Remove the water pump.
Remove and discard the o-ring seal.

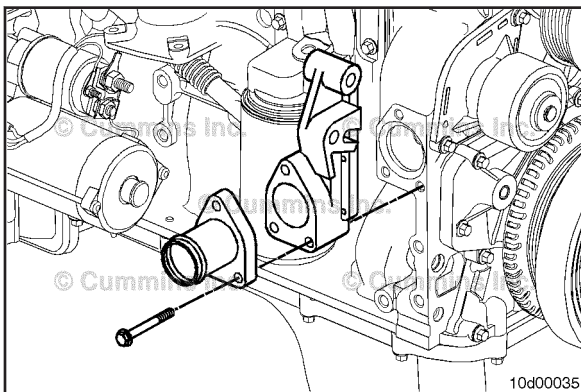

Water Inlet Connection (008-082)

Remove

Remove the coolant hoses.
Remove the capscrews, water inlet connection, gasket, and rectangular sealing ring.

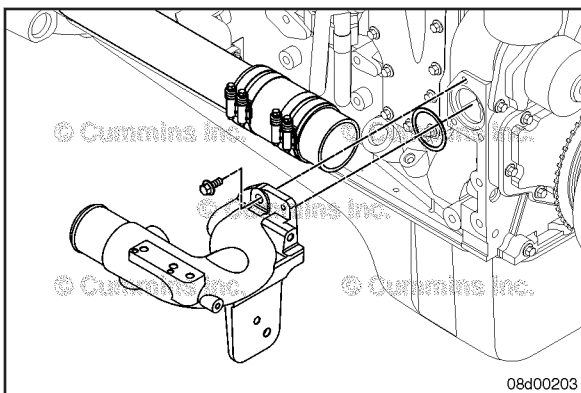

Loosen and slide the two hose clamps on the coolant return junction connection hose back on the coolant return junction.

Remove the three mounting capscrews from the water inlet connection.

Slide the water inlet connection from the coolant return junction and remove the water pump inlet and sealing ring. Discard the sealing ring.

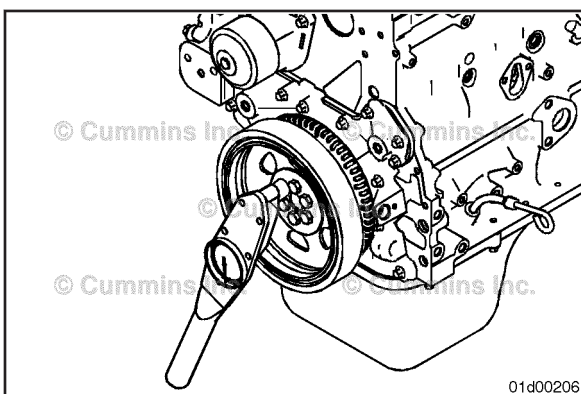

Vibration Damper, Rubber (001-051)

Remove

For front gear train engines, remove the four capscrews.

For rear gear train engines, remove the six capscrews.

NOTE: For 3.9 L and 5.9 L engines, the crankshaft speed indicator ring is held in place by the same capscrews as the vibration damper. For 4.5 L and 6.7 L, with a rear gear train, the crankshaft speed indicator ring is a part of the vibration damper assembly and should **not** be removed from the vibration damper.

Remove the vibration damper and crankshaft speed indicator ring.

Vibration Damper, Viscous (001-052)

Remove

For front gear train engines, remove the four capscrews.

For rear gear train engines, remove the six capscrews.

NOTE: For 3.9 L and 5.9 L engines, the crankshaft speed indicator ring is held in place by the same capscrews as the vibration damper. For 4.5 L and 6.7 L, with a rear gear train, the crankshaft speed indicator ring is a part of the vibration damper assembly and should **not** be removed from the vibration damper.

Remove the vibration damper.

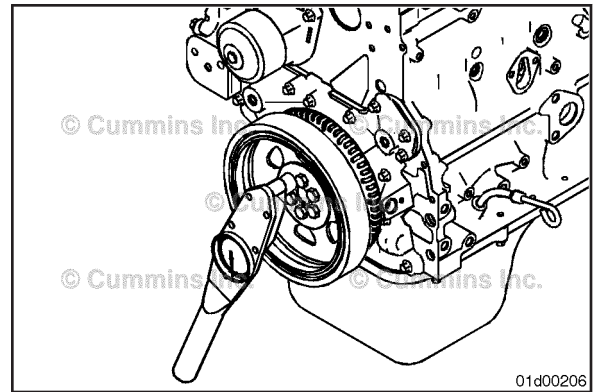

Crankshaft Speed Indicator Ring (001-071)

Remove

If the engine is **not** equipped with a vibration damper, remove the six capscrews that hold the crankshaft speed indicator ring/pulley to the nose of the crankshaft.

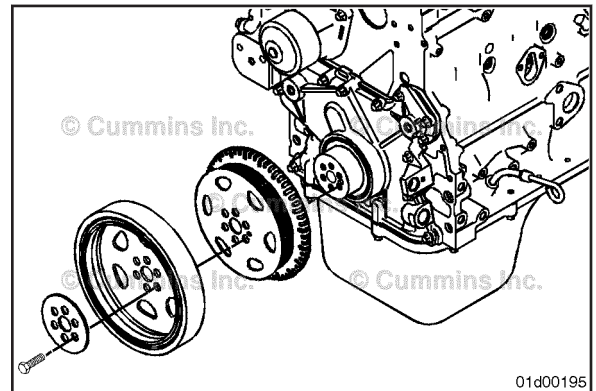

Crankshaft Seal, Front (001-023)

Remove

Support the front gear cover on a flat work surface with wooden blocks. Using a suitable punch and hammer, drive the old seal out of the front gear cover from the back side of the cover to the front side.

NOTE: Some engines may have an additional dust seal installed in front of the front crankshaft seal.

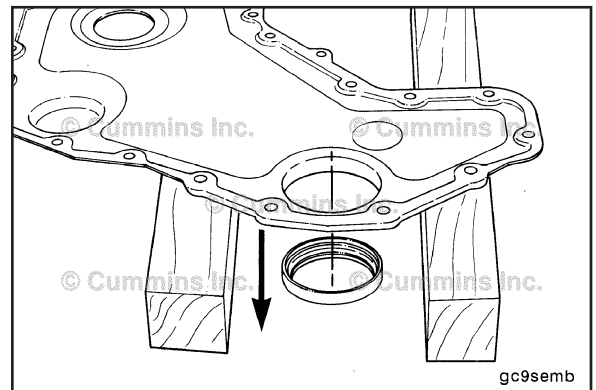

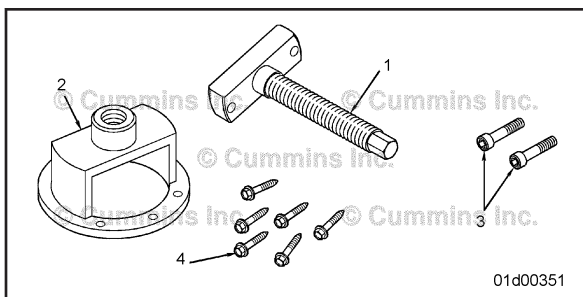

Use tool, Part Number 3164659, to remove the front crankshaft seal from the front gear cover.

Table 1. Front Crankshaft Seal Replacer Kit, Part Number 3164659

Item Number	Part Number	Description	Quantity
1	3164667	Replace screw assembly	1
2	3164661	Crankshaft seal replacer	1
3	3164239	Socket head capscrew, M12 x 1.25 x 60 mm	2
4	3164217	Sheet metal screw, Number 10 x 25.4 mm [1 in] long	25 (6 shown)
Not shown	3164218	Drill. 3.57 mm [9/64 in]	1

NOTE: The front gear cover does **not** need to be removed to remove and install the crankshaft seal.

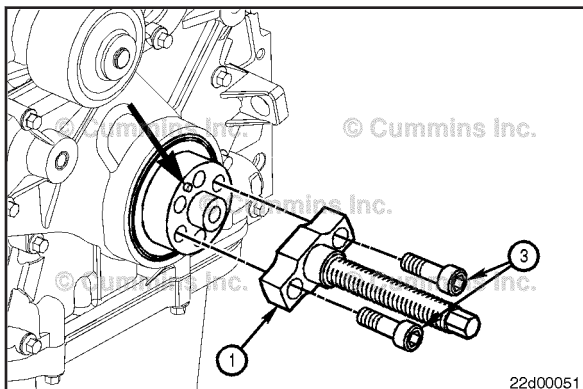

Mount the replacer screw assembly (1) onto the crankshaft nose.

Install the two M12 x 1.25 x 60-mm socket head capscrews (3).

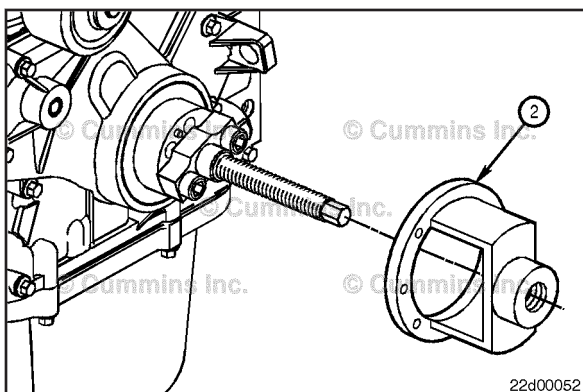

Lubricate the replacer screw with anti-seize or a suitable grease.



Hold the replacer screw and install the crankshaft seal replacer (2) onto the replacer screw assembly. Advance the crankshaft seal replacer toward the seal by rotating it **clockwise** until it is positioned against the front gear cover.

⚠CAUTION⚠

Drill the hole carefully and straight to reduce the possibility of damage to the front cover or the crankshaft.

Service Tip: Because of space restrictions, it may be necessary to use a compact right angle drill. Also, it may be necessary to shorten the drill bit used to drill the sheet metal screw holes.

NOTE: The flange of the crankshaft seal replacer is 8 mm [0.32 in] thick.

Mark the drill to a depth of 18 mm [0.71 in] with tape for drill depth control and apply grease to the drill to catch the chips. Stop frequently to remove the chips.

With the crankshaft seal replacer positioned against the front gear cover, drill one hole 10 mm [0.39 in] deep. Make sure the marking tape has **not** moved from the original position.

Install one sheet metal screw (4) into the seal to hold the crankshaft seal replacer in position.

Drill five additional holes 10 mm [0.39 in] deep and install the additional five sheet metal screws.

NOTE: Make sure all six sheet metal screws are threaded through both the inner and outer seal casings. The sheet metal screws need to be uniformly tightened in order to pull out the inner and outer casings of the seal together.

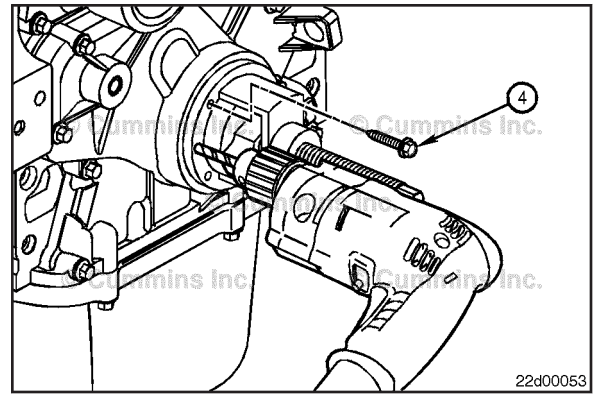

⚠CAUTION⚠

Do not use an impact wrench or air tools. Doing so can damage the tool.

Slowly rotate the replacer screw **clockwise** until the seal is removed. Do **not** exceed torque value.

Torque Value: 33 N•m [45 ft-lb]

NOTE: If the sheet metal screws pull out of the seal or **only** the inner casing pulls out, stop the removal operation. Rotate the replacer screw **counterclockwise** to force the inner casing back. Remove the sheet metal screws, slightly reorient the tool, drill new holes, and install the sheet metal screws in the new locations.

Complete the removal procedure, remove the tool, and discard the old seal.

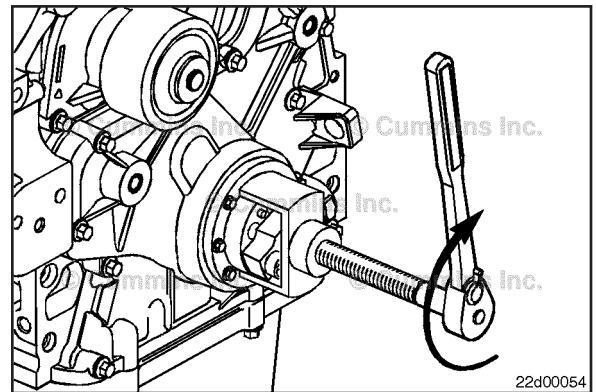

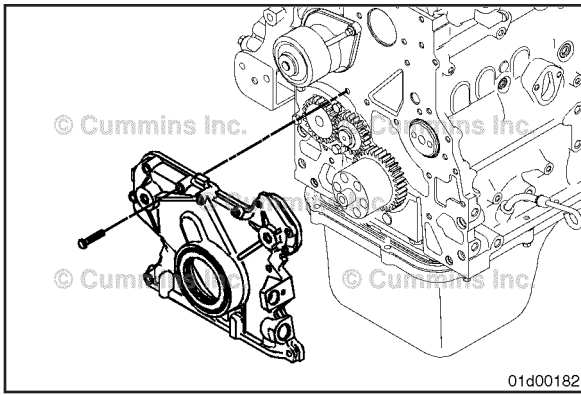

Gear Cover, Front (001-031)

Remove

Rear Gear Train

⚠CAUTION⚠

Some rear gear train engines, with a cast aluminum front gear cover, have two threaded holes to aid in the removal of the front gear cover. When looking at the front of the front gear cover, there is a threaded through hole in the lower right-hand corner that can be used with a jackscrew. On the lower left-hand corner, there is a threaded blind hole. A capscrew can be inserted into that blind hole to be used with a slide hammer. Do not use the lower left-hand threaded blind hole as a jackscrew or the front gear cover will be damaged.

Remove the front gear cover mounting capscrews.

⚠CAUTION⚠

To break the seal, pry the front gear cover away from the front gear housing. Be careful not to damage the front gear cover when breaking the seal to the front gear housing.

Remove the front gear cover.

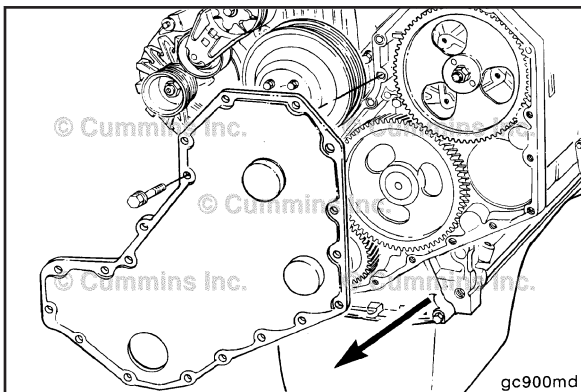

Front Gear Train

⚠CAUTION⚠

To break the seal, pry the front gear cover away from the front gear housing. Be careful not to damage the front gear cover when breaking the seal to the front gear housing.

Remove the front gear cover mounting capscrews.

Remove the front gear cover with the front crankshaft seal.

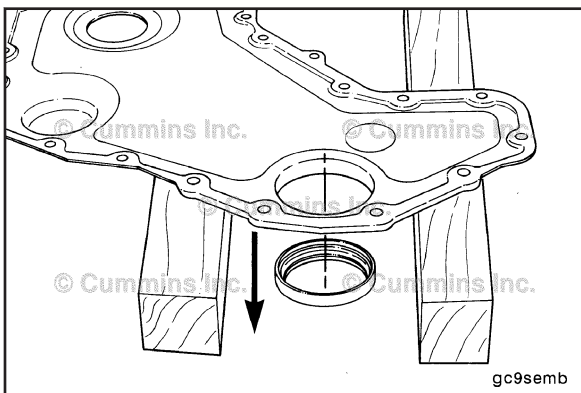

Support the front gear cover on a flat work surface with wooden blocks. Using a suitable punch and hammer, drive the old seal out of the front gear cover from the back side of the cover to the front side.

NOTE: Some engines have an additional dust seal installed in front of the front crankshaft seal.

Lubricating Oil Pump (007-031)

Remove

Remove the four mounting capscrews (1, 2, 3, and 4).
Remove the lubricating oil pump from the bore in the cylinder block.

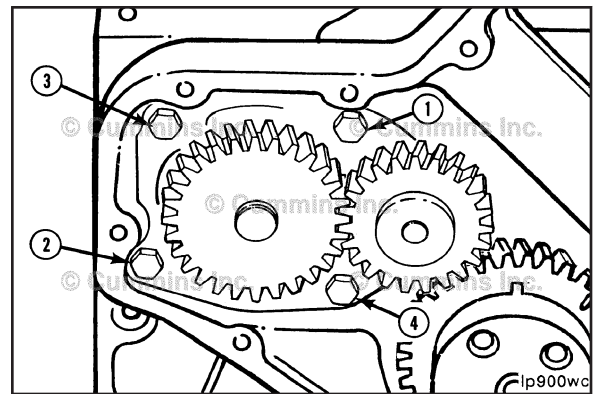

Cylinder Head (002-004)

Remove



This component weighs 23 kg [50 lb] or more. To reduce the possibility of personal injury, use a hoist or get assistance to lift this component.



If removing the cylinder head with the injectors installed, be careful not to damage the tips of the injector. Do not set the cylinder head down on the combustion face with the injectors installed. Damage to the injector tips will result.

Remove the cylinder head capscrews and cylinder head.

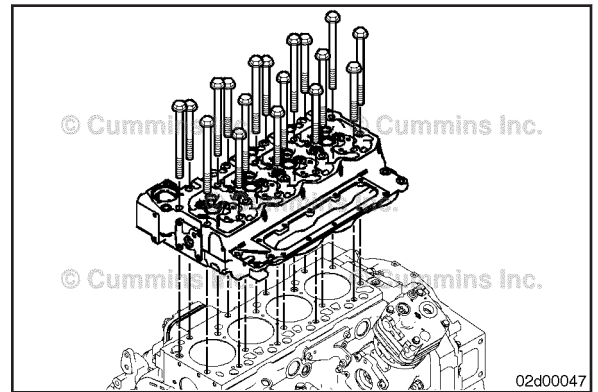

Remove the cylinder head gasket from the cylinder block.

NOTE: Do **not** discard the head gasket. For some engines that require head gasket grading, the head gasket will help to determine which replacement head gasket to use. Refer to Procedure 002-021 in Section 2.

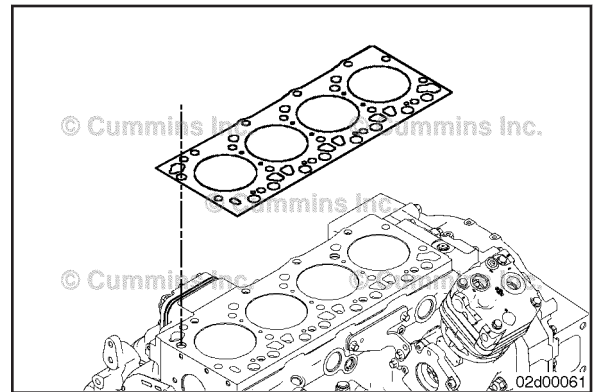

Cylinder Head Gasket (002-021)

Remove

Remove the cylinder head gasket.

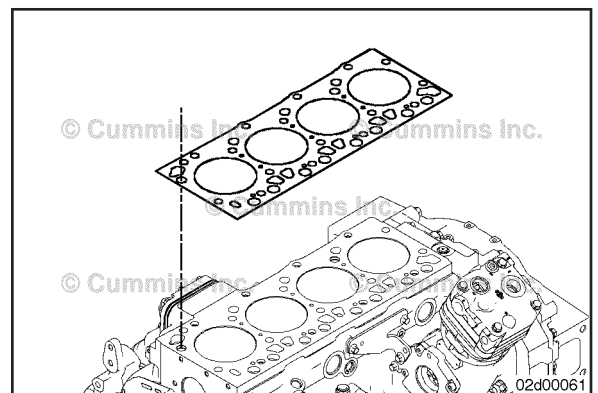

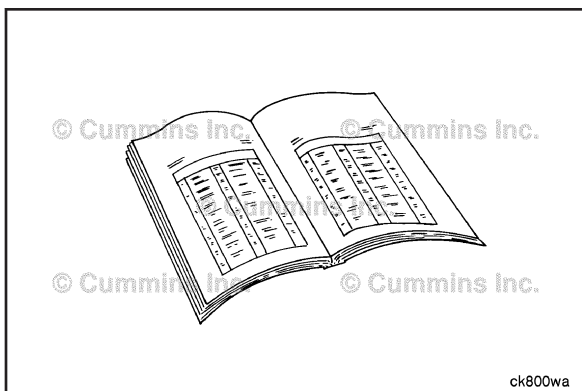

Injector (006-026)

Preparatory Steps



⚠ CAUTION ⚠

The fuel connector must be removed before removing the injector or damage to the connector will result.

- Remove the high-pressure fuel line from the fuel rail and high-pressure connector. Refer to Procedure 006-051 in Section 6.
- Remove the high-pressure connector. Refer to Procedure 006-052 in Section 6.
- Remove the rocker lever cover. Refer to Procedure 003-011 in Section 3.
- Remove the exhaust rocker lever. Refer to Procedure 003-008 in Section 3.

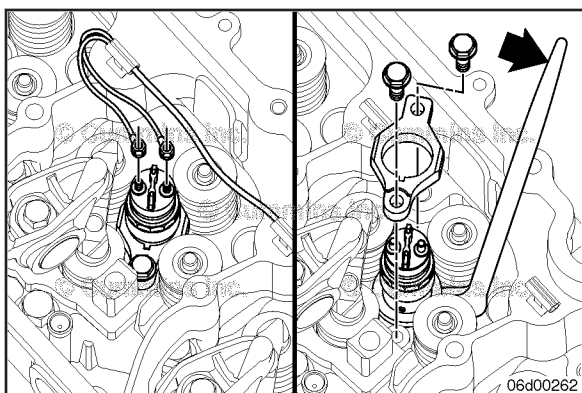

Remove

Disconnect the solenoid wires.

Remove the two injector hold-down capscrews and remove the injector hold-down clamp.

NOTE: The injector hold-down clamp is **not** removable on all engines.

Use the injector remover, Part Number 3823024, to remove the injector from the cylinder head.

NOTE: A small heel pry bar can also be used to pry up the injector. Pry up the injector hold-down flange (part of the injector body just above the cylinder head casting).

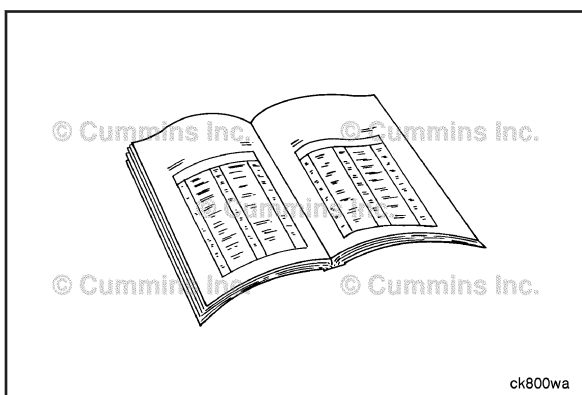

Finishing Steps



- Install the exhaust rocker and adjust the exhaust valve lash. Refer to Procedure 003-008 in Section 3.
- Install the rocker lever cover. Refer to Procedure 003-011 in Section 3.
- Install the high-pressure fuel line from the fuel rail to the high-pressure connector. Refer to Procedure 006-051 in Section 6.
- For Marine applications, **open** fuel supply and return valves.
- Operate the engine and check for leaks.

Lubricating Oil Pan (007-025)

Remove

Oil Pan, Suspended

Remove the lubricating oil pan support mounting flange and gasket.

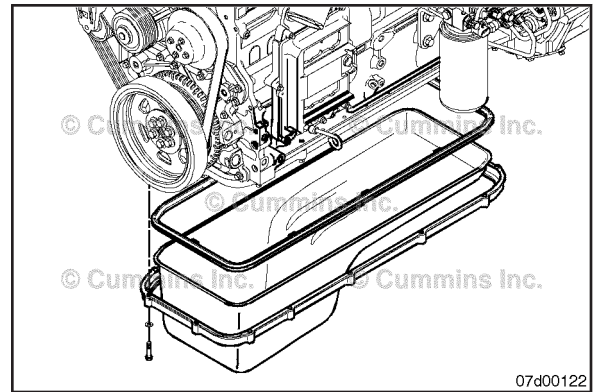

Remove the suction tube, if necessary. Refer to Procedure 007-035 in Section 7.

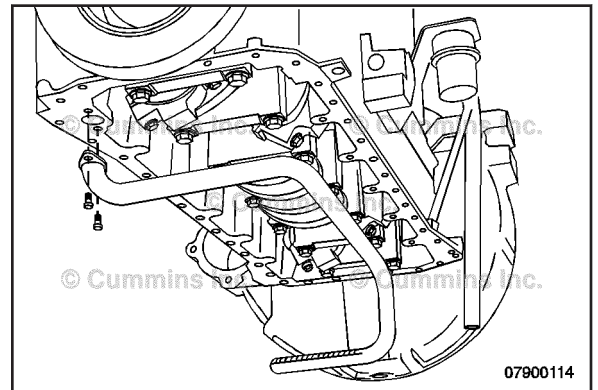

Oil Pan, Standard

Remove the lubricating oil pan and gasket.

Discard the gasket.

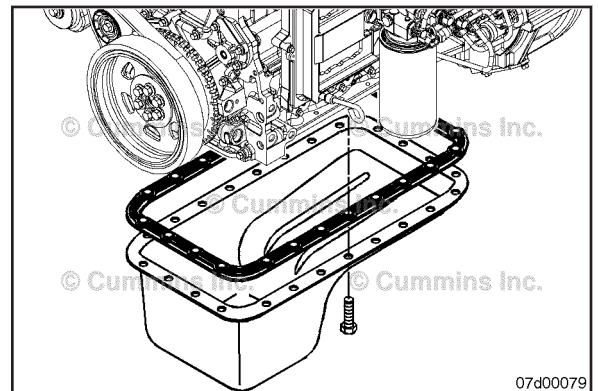

Remove the suction tube, if necessary. Refer to Procedure 007-035 in Section 7.

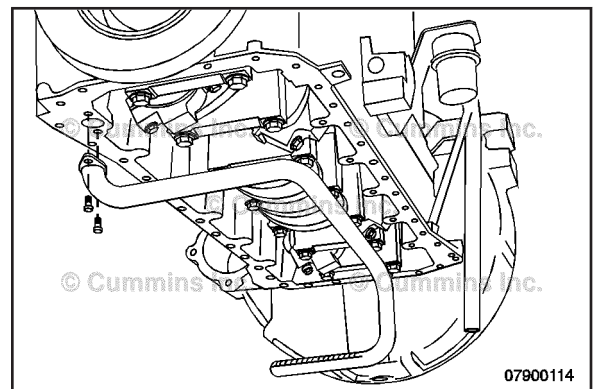

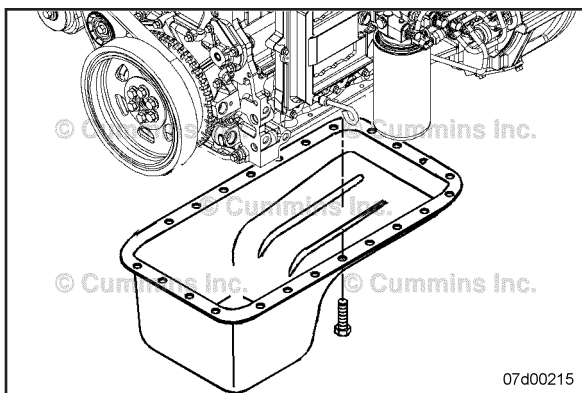

Oil Pan, Formed-in-Place Gasket

Remove the lubricating oil pan.

NOTE: You can damage the lubricating oil pan flange by using a pry bar or screwdriver to break the formed-in-place gasket seal. Use a utility knife to cut the seal and loosen the pan.

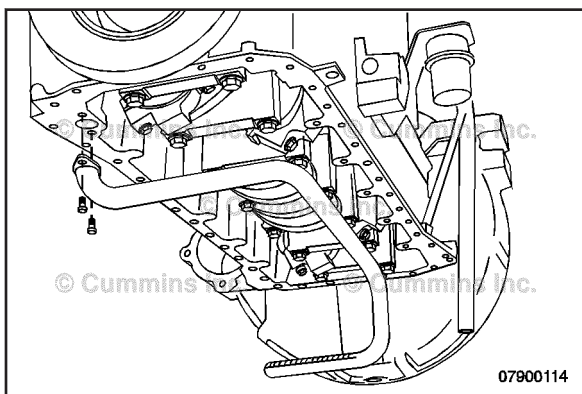

Remove the suction tube, if necessary. Refer to Procedure 007-035 in Section 7.

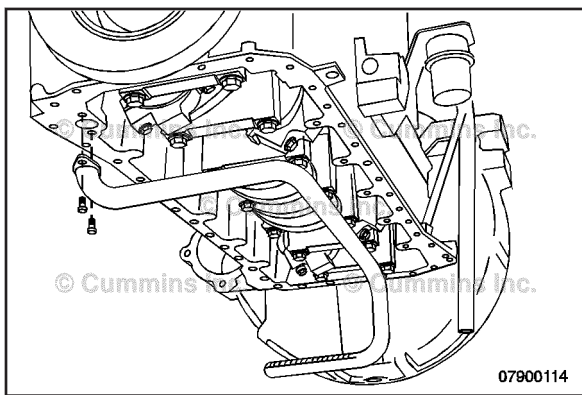

Lubricating Oil Suction Tube (Block-Mounted) (007-035)

Remove

Remove the suction tube mounting capscrews.
Remove the suction tube.

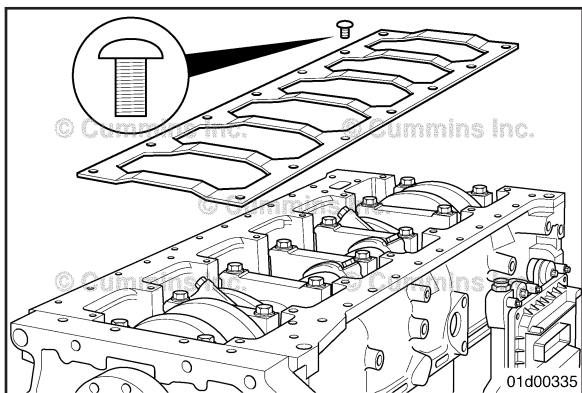

Block Stiffener Plate (001-089)

Remove

NOTE: For some oil pan/oil suction tube configurations, the block stiffener plate capscrew closest to the lubricating oil suction tube may be different than the rest. If equipped, note the capscrews location for installation. The low profile capscrew ensures in some applications that there is sufficient clearance between the oil suction tube and the block stiffener mounting capscrew.

Remove the capscrews and block stiffener plate.

Camshaft Gear (Camshaft Installed) (001-012)

Remove

Rotate the engine to allow the camshaft timing marks to align. When the timing marks are aligned, cylinder 1 is at top dead center (TDC).

NOTE: The engine can have a mark on the camshaft gear or chamfered tooth.

Service Tip: Engines equipped with air compressors may require that the air compressor be timed to the engine. To make sure that the air compressor is properly timed when the camshaft gear is later installed, scribe an alignment line on the air compressor and camshaft gear before removing the camshaft gear.

On engines equipped with an air compressor, it is necessary to loosen the air compressor mounting hardware in order to remove the camshaft gear. It is **not** necessary to remove the air compressor completely. Loosening the air compressor will give enough clearance to remove the camshaft gear.

Remove the camshaft gear capscrews.

Remove the camshaft gear.

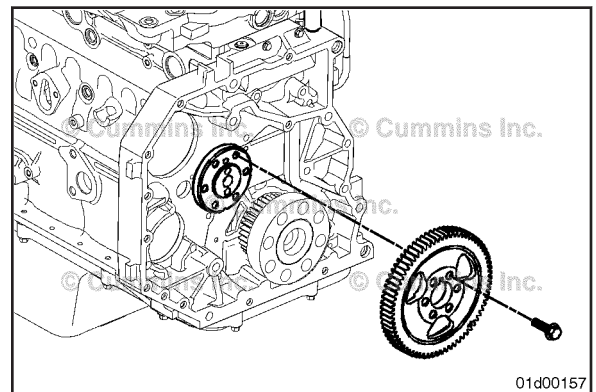
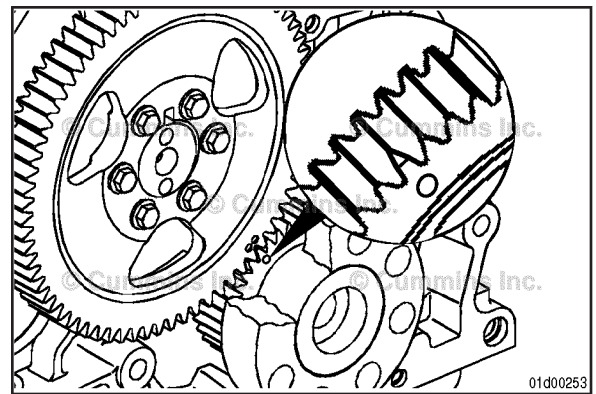

Camshaft (001-008)

Remove

Rear Gear Train

Before the camshaft can be removed, the tappets **must** be lifted off the camshaft lobes.

With the engine removed and on an engine stand, rotate the engine so the oil pan side of the engine is up. This will allow the tappets to fall off the camshaft lobes prior to the camshaft being removed.

Inspect the tappets to make sure they are no longer in contact with the camshaft lobes prior to removing the camshaft.

NOTE: The following illustrations show the engine in the upright position for clarity.

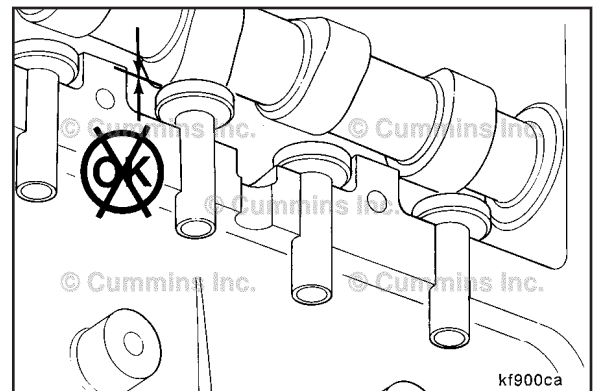

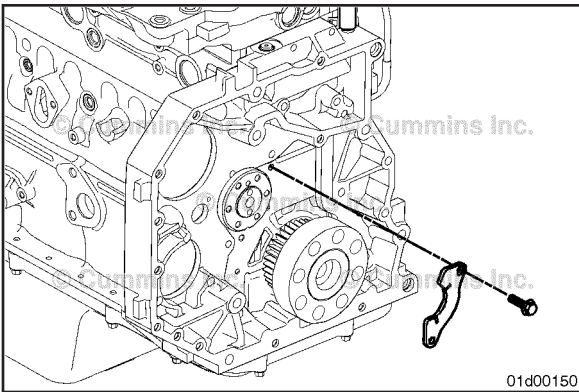

Remove the thrust plate cap screws and the thrust plate.

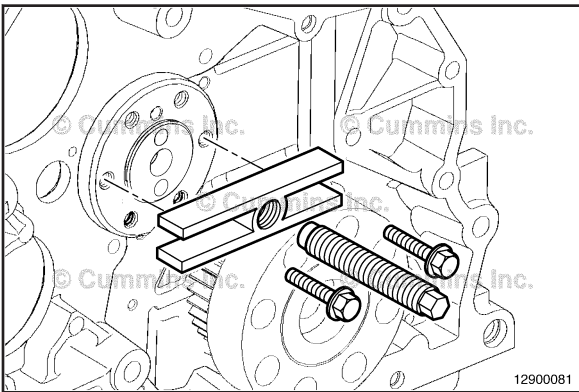

⚠ CAUTION ⚠

The camshaft will drop once the camshaft clears the last bushing, if not supported. This can cause damage to the camshaft journal or, if equipped, the camshaft speed indicator ring.



Use a gear puller, service tool Part Number ST647, or equivalent, to attach to the end of the camshaft, where the camshaft gear mounts, to act as a handle. This will give proper leverage and ease in removing the camshaft.

Slide the camshaft out of the bore using the installed gear puller.

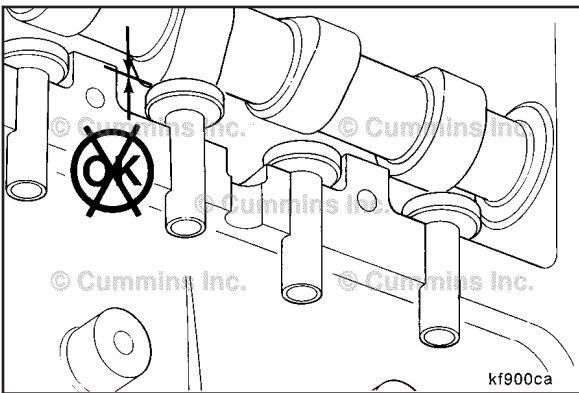

Front Gear Train

Before the camshaft can be removed, the tappets **must** be lifted off the camshaft lobes.

With the engine removed and on an engine stand, rotate the engine so the oil pan side of the engine is up. This will allow the tappets to fall off the camshaft lobes prior to the camshaft being removed.

Inspect the tappets to make sure they are no longer in contact with the camshaft lobes prior to removing the camshaft.

NOTE: The following illustrations show the engine in the upright position for clarity.

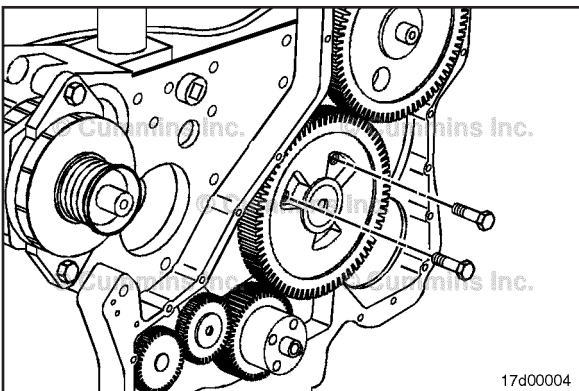

Because the thrust plate extends more than 180 degrees around the camshaft, the thrust plate can **only** be removed from the camshaft after removing the camshaft gear from the camshaft.

Remove the cap screws from the thrust plate.

Remove the camshaft, camshaft gear, and thrust plate as an assembly.

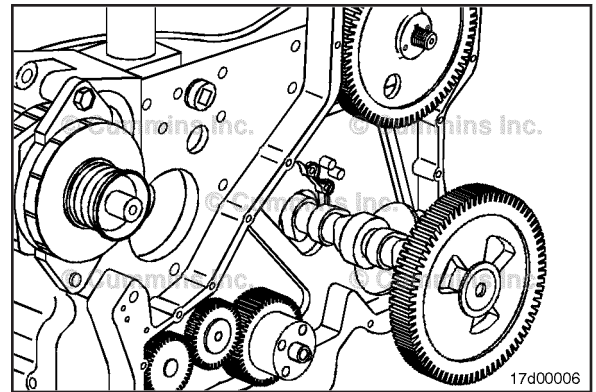

Tappet (004-015)

Remove

With the camshaft removed, remove the tappets through the bottom of the engine.

Mark the position of the tappets as they are removed. If reused, the tappets **must** be installed in the same position when the engine is assembled.

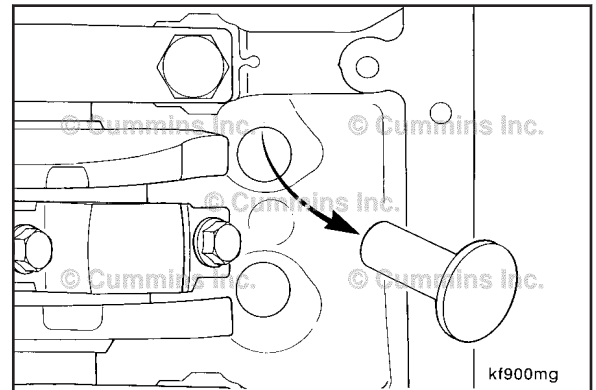

Gear Housing, Front (001-033)

Remove

Remove the four front oil pan capscrews.

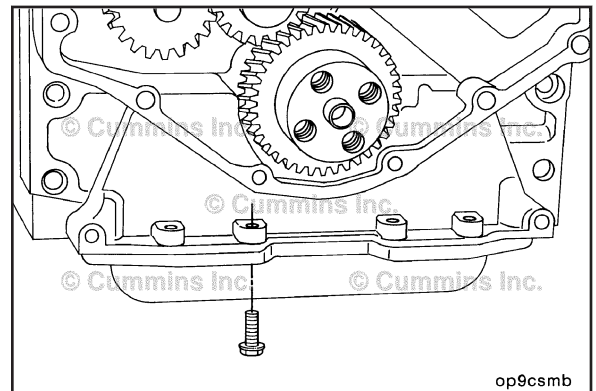

Remove the gear housing capscrews.

Note the location of the gear housing capscrews as they are removed. Some of the capscrews are an internal torx fastener and **must** be installed in the same location as removed to ensure proper clearance.

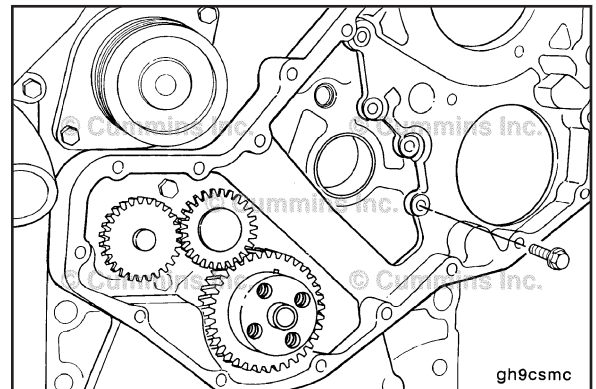

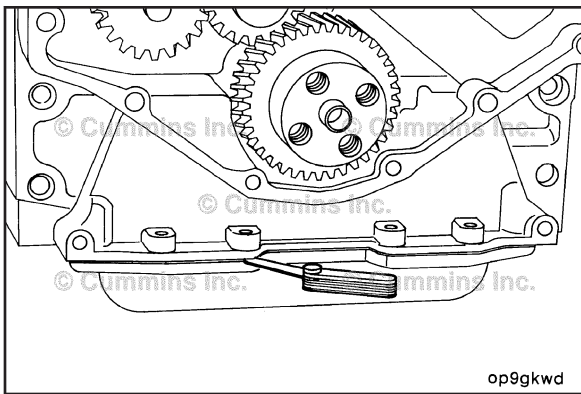

Using a feeler gauge, separate the lubricating oil pan gasket from the gear housing.

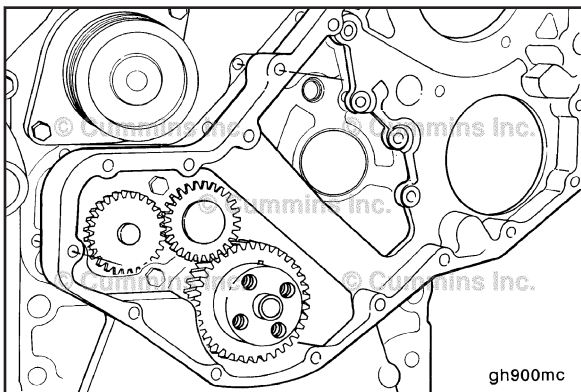

Use a plastic hammer to loosen the front gear housing.
Remove the gear housing.

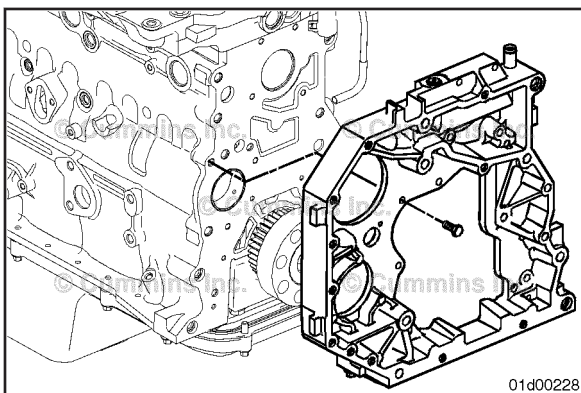

Gear Housing, Rear (001-034) **Remove**

Remove the rear gear housing capscrews and housing.

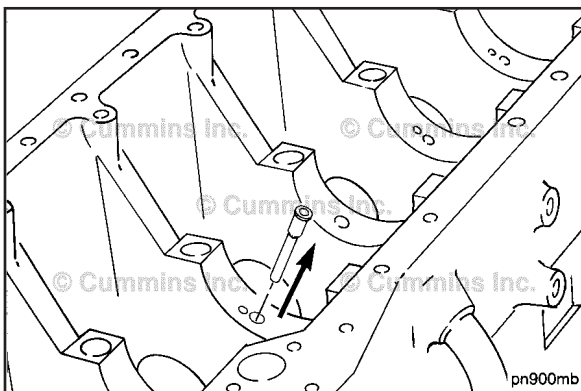

Piston Cooling Nozzle (001-046) **Remove**

Remove the piston cooling nozzles or plugs by pressing from the top with an appropriate size punch.

NOTE: Do not reuse the saddle jet piston cooling nozzles or plugs once removed.

NOTE: Blocks using saddle jet piston cooling nozzles may be machined for J-jet piston cooling nozzles as well. If this is the case, capscrews will be installed in the J-jet piston cooling nozzle location. If it is necessary to remove these capscrews, follow the J-jet piston cooling nozzle removal procedure below.

Rotate the crankshaft to various positions to access each piston cooling nozzle and/or capscrew.

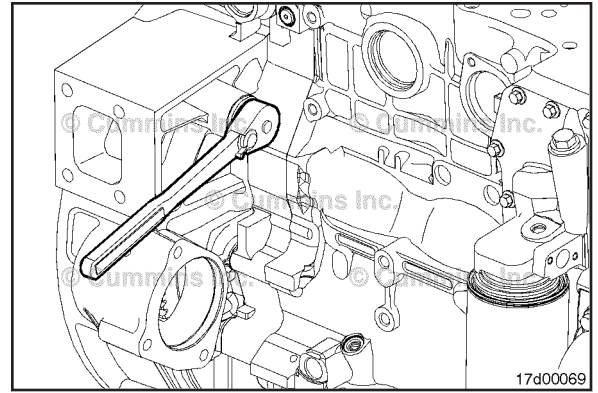

Remove the piston cooling nozzles and/or capscrews.

NOTE: Blocks using J-jet piston cooling nozzles may be machined for saddle jet piston cooling nozzles as well. If this is the case, plugs will be installed in the saddle jet piston cooling nozzle locations. If it is necessary to remove these plugs, please follow the saddle jet piston cooling nozzle removal procedures outlined earlier in this procedure.

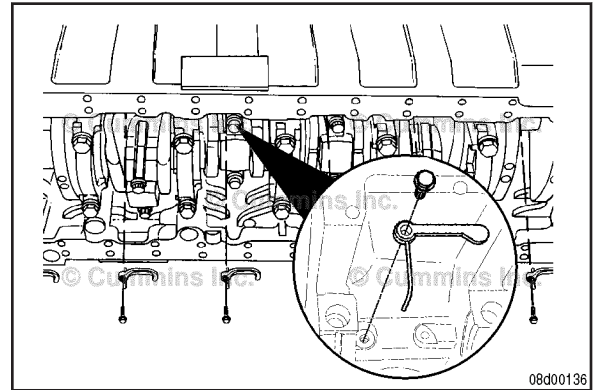

Piston and Connecting Rod Assembly (001-054)

Remove

⚠ WARNING ⚠

When using solvents, acids, or alkaline materials for cleaning, follow the manufacturer's recommendations for use. Wear goggles and protective clothing to reduce the possibility of personal injury.

⚠ WARNING ⚠

Some solvents are flammable and toxic. Read the manufacturer's instructions before using.

Rotate the crankshaft until the pistons are below the carbon deposits that are found above the ring travel area.

Use a fine fibrous abrasive pad, Part Number 3823258 or equivalent, and solvent to remove the carbon.

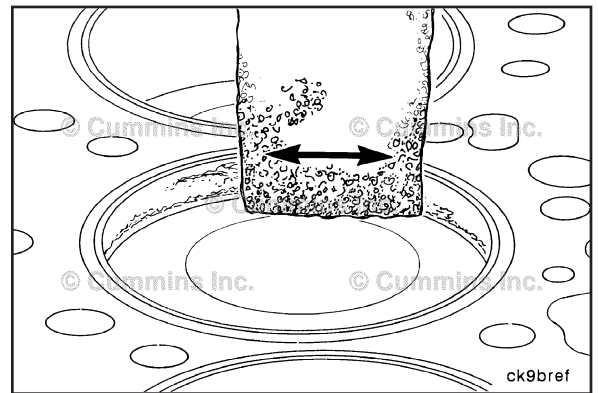

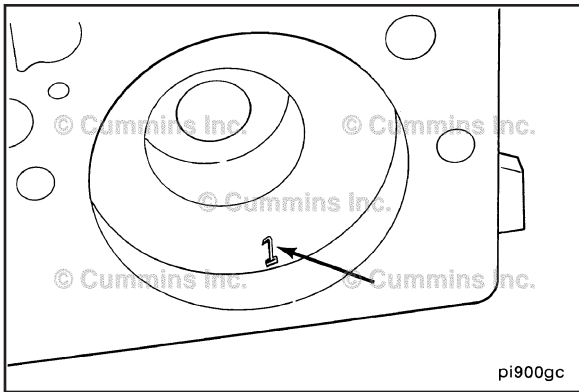

Mark each piston according to the cylinder location.

NOTE: On pistons with anodized coatings, do **not** stamp on the anodized coating or on the outer rim. Do **not** stamp on the aluminum piston crown above the piston pin axis.

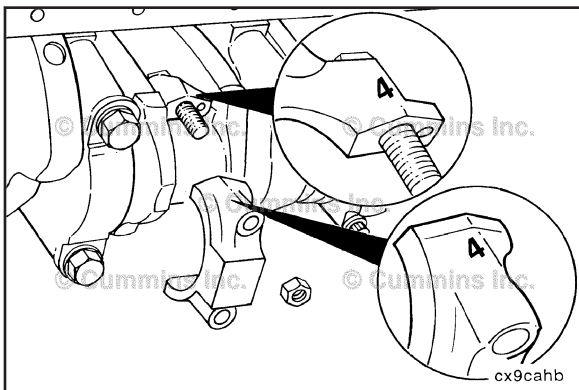

Rotate the crankshaft to position the rod caps at bottom dead center for removal.

Mark each connecting rod and rod cap according to the cylinder number location.

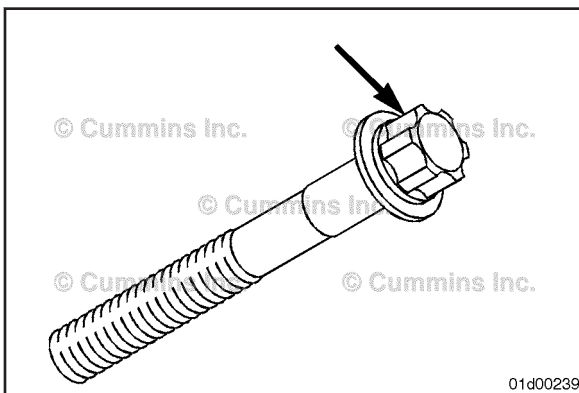

Some engines are equipped with an external Torx bit (E-12).

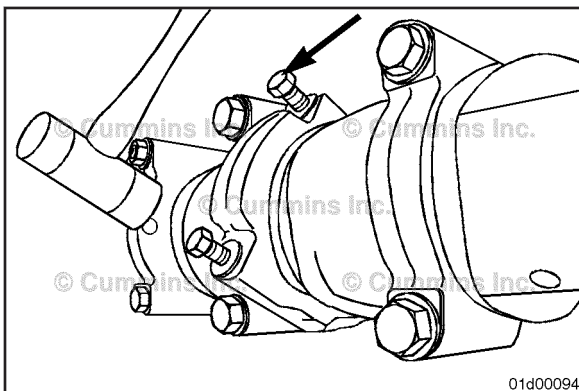

Loosen the connecting rod capscrews.

Do **not** remove the capscrews from the rods at this time.

Use a rubber hammer to hit the connecting rod capscrews to loosen the caps.

⚠CAUTION⚠

Do not damage the fractured split surface on the connecting rod or connecting rod cap while the connecting rod cap is removed. If the fractured split surface is damaged, the connecting rod and connecting rod cap must be replaced to help reduce the possibility of engine damage. Incorrect assembly can damage the rod.

⚠CAUTION⚠

When setting the rod cap down, do not set the cap down on the fractured split surface. Damage to the fractured split surface can result.

Remove the connecting rod capscrews.

Remove the rod cap.

Remove the lower rod bearing.

Mark the cylinder number and the letter "L" (lower) on the flat surface of the bearing tang.

Push the connecting rod and piston assembly out of the cylinder bore. Care **must** be taken **not** to damage the connecting rod or bearing.

Remove the upper rod bearing.

Mark the cylinder number and the letter "U" (upper) on the flat surface of the bearing tang.

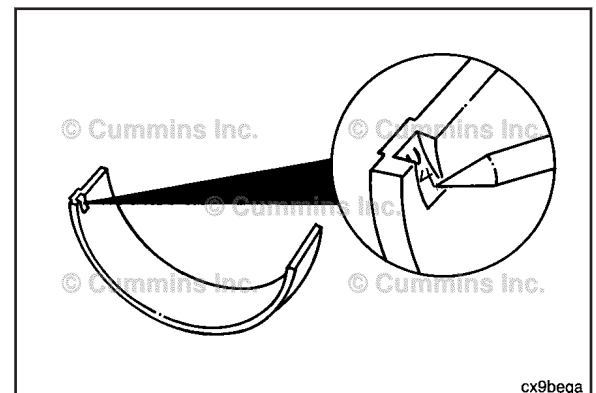
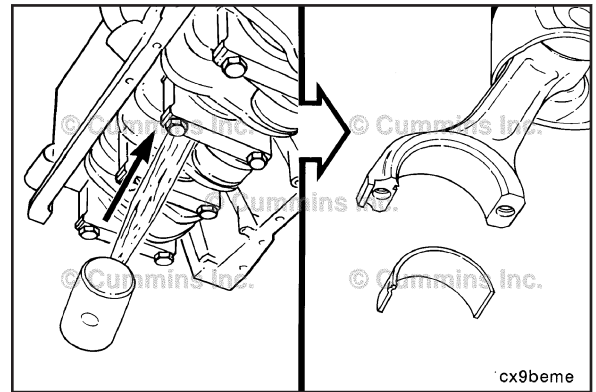
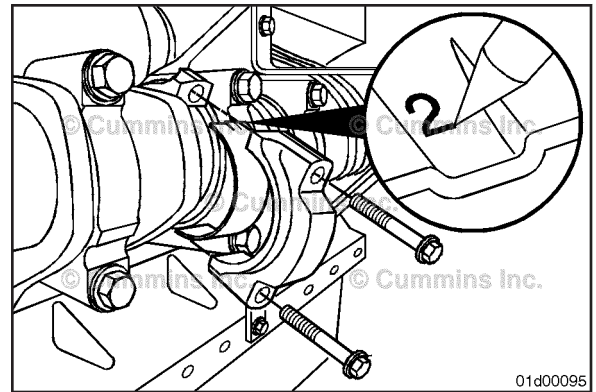

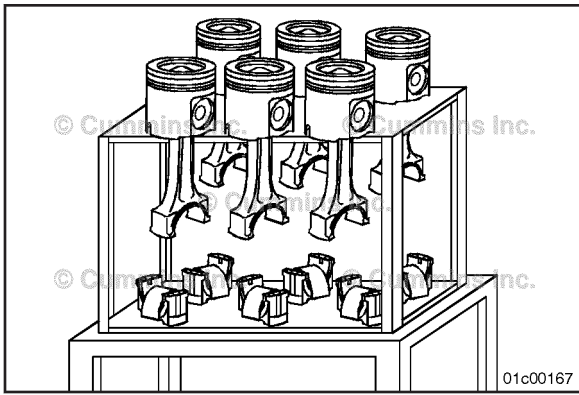

The piston and connecting rod assemblies **must** be installed in the same cylinder number they were removed from to provide for proper fit of worn mating surfaces if parts are reused.

Use a tag to mark the cylinder number that each piston and rod assembly was removed from.

Place the rod and piston assemblies in a container to protect them from damage.

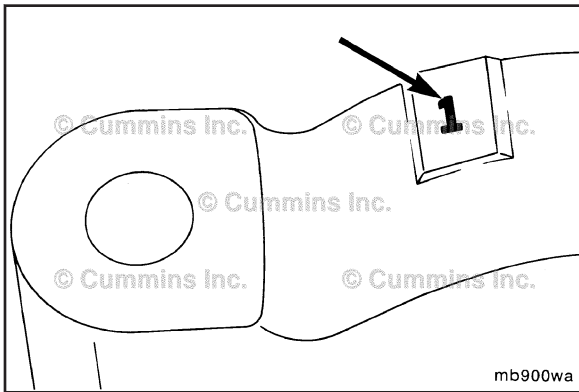

Crankshaft (001-016) Remove

Before removing the main bearing caps, make certain that the caps are clearly marked for their location on the lubricating oil cooler side of the main bearing cap and cylinder block.

The number 1 cap is at the front of the engine.

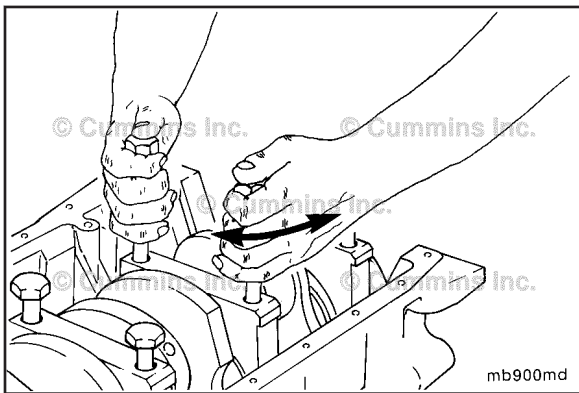

Loosen the main bearing capscrews completely, but do **not** remove.

⚠CAUTION⚠

Do not pry on the main bearing caps to free them from the cylinder block. Damage to the main bearing caps and cylinder block can result.

Use two of the main bearing cap bolts to “wiggle” the main bearing cap loose, being careful **not** to damage the bolt threads.

Remove the main bearing cap.

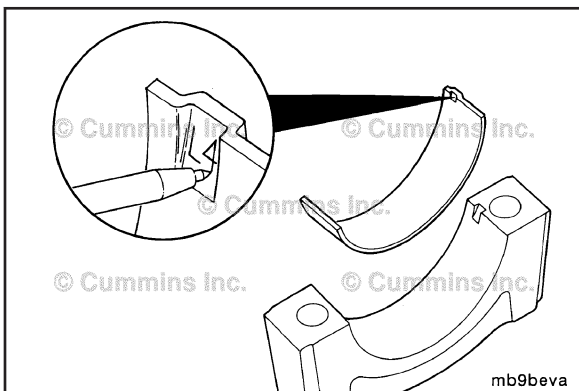

Mark the lower main bearings for position and number as they are removed.

Use an awl to mark the bearing position in the tang area.

NOTE: Mark the bearing's position for future identification or possible failure analysis.

⚠ WARNING ⚠

This component or assembly weighs greater than 23 kg [50 lb]. To prevent serious personal injury, be sure to have assistance or use appropriate lifting equipment to lift this component or assembly.

NOTE: Lift the crankshaft straight up to avoid damage to the crankshaft and cylinder block.

For 6 cylinder engines, install the nylon lift sling, Part Number 3375957, around the number 3 and number 4 rod bearing journals.

For 4 cylinder engines, install the nylon lift sling, Part Number 3375957, around the number 2 and number 3 rod bearing journals.

Attach the sling to a hoist and remove the crankshaft.

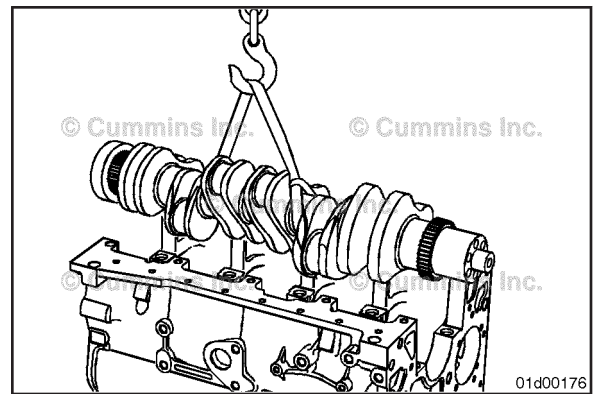

Remove the upper main bearings.

Use an awl to mark the bearing's position in the tang area.

NOTE: Mark the bearing's position for future identification or possible failure analysis.

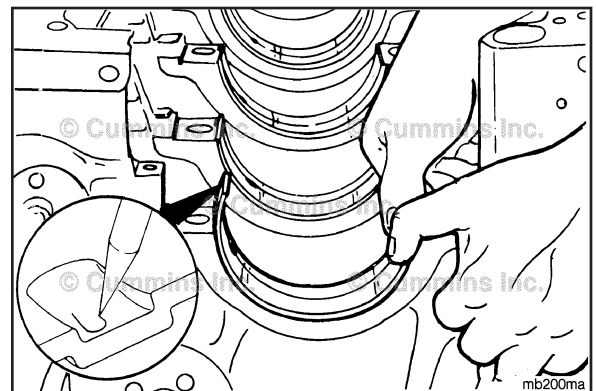

Camshaft Bushings (001-010)

Remove

Remove the camshaft bushings using the camshaft bushing replacer kit, Part Number 3165045. The tool will drive the camshaft bushing to the inside of the block. The camshaft bushing can be retrieved from the bottom of the engine.

NOTE: Once removed, camshaft bushings can **not** be reused.

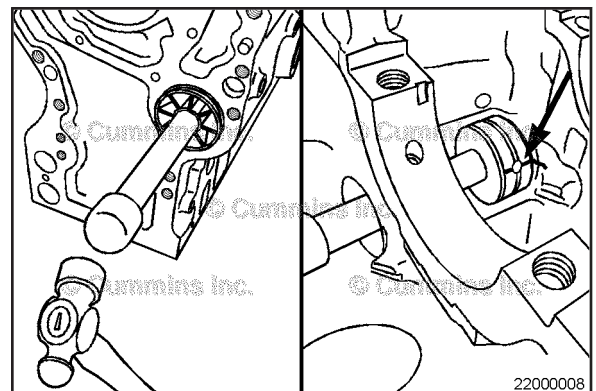

Section AS - Engine Assembly - Group 00

Section Contents

	Page
Accessory Drive	AS-34
Initial Check.....	AS-34
Install.....	AS-35
Air Compressor	AS-32
Install.....	AS-33
Time.....	AS-32
Air Intake Connection	AS-51
Install.....	AS-51
Air Intake Connection Adapter	AS-53
Install.....	AS-53
Air Intake Manifold	AS-37
Install.....	AS-37
Alternator	AS-94
Install.....	AS-94
Alternator Bracket	AS-93
Install.....	AS-93
Spool Mount.....	AS-93
Pad Mount.....	AS-93
Marine Applications.....	AS-94
Belt Guard	AS-99
Install.....	AS-99
Block Stiffener Plate	AS-21
Install.....	AS-21
Camshaft	AS-17
Install.....	AS-17
Camshaft Bushings	AS-1
Install.....	AS-1
Camshaft Gear (Camshaft Installed)	AS-20
Install.....	AS-20
Coolant Thermostat Housing	AS-91
General Information.....	AS-91
Install.....	AS-91
Coolant Thermostat Housing Support	AS-91
General Information.....	AS-91
Install.....	AS-91
Coolant Vent Lines	AS-92
Install.....	AS-92
Crankcase Breather (External)	AS-69
Install.....	AS-69
Crankcase Breather (Internal)	AS-69
Install.....	AS-69
Crankcase Breather Tube	AS-77
Install.....	AS-77
Crankshaft	AS-2
Install.....	AS-2
Crankshaft Seal, Front	AS-58
Install.....	AS-58
Crankshaft Seal, Rear	AS-78
Install.....	AS-78
Crankshaft Speed Indicator Ring	AS-60
Install.....	AS-60
Crankshaft Wear Sleeve, Rear	AS-72
Install.....	AS-72
Crosshead	AS-63
Install.....	AS-63
Cylinder Head	AS-28
Install.....	AS-28

Cylinder Head Gasket	AS-24
Install.....	AS-27
Measure.....	AS-24
ECM Cooling Plate, Fuel Cooled	AS-36
Install.....	AS-36
ECM Mounting Plate	AS-36
Install.....	AS-36
Engine Support Bracket, Front	AS-97
Install.....	AS-97
Engine Support Bracket, Rear	AS-97
Install.....	AS-97
Exhaust Manifold, Dry	AS-84
Install.....	AS-84
Fan Hub, Belt Driven	AS-96
Install.....	AS-96
Fan Spacer and Pulley	AS-96
Install.....	AS-96
Flexplate	AS-89
Install.....	AS-89
Flywheel	AS-87
Install.....	AS-87
Flywheel Housing	AS-75
Install.....	AS-75
Fuel Connector (Head Mounted)	AS-48
Finishing Steps.....	AS-48
Install.....	AS-48
Fuel Drain Lines	AS-43
Install.....	AS-43
Fuel Filter (Spin-On Type)	AS-40
Install.....	AS-40
Fuel Filter Head	AS-38
Install.....	AS-38
Low Mount Fuel Filter.....	AS-38
High Mount Fuel Filter.....	AS-39
Marine Applications.....	AS-39
Fuel Lift Pump	AS-35
Install.....	AS-35
Fuel Pump	AS-30
Install.....	AS-30
Fuel Rail	AS-49
Install.....	AS-49
Fuel Supply Lines	AS-40
Install.....	AS-40
Gear Cover, Front	AS-55
Install.....	AS-55
Gear Housing, Front	AS-14
Install.....	AS-14
Gear Housing, Rear	AS-13
Install.....	AS-13
Injector	AS-45
Finishing Steps.....	AS-48
Install.....	AS-45
Remove.....	AS-45
Injector Supply Lines (High Pressure)	AS-50
Install.....	AS-50
Lubricating Oil Cooler	AS-82
Install.....	AS-82
Lubricating Oil Dipstick Tube	AS-96
Install.....	AS-96
Lubricating Oil Filter (Spin-On)	AS-83
Install.....	AS-83
Lubricating Oil Lines	AS-99
Install.....	AS-99
Lubricating Oil Pan	AS-22

Install.....	AS-22
Lubricating Oil Pump	AS-54
Install.....	AS-54
Lubricating Oil Suction Tube (Block-Mounted)	AS-21
Install.....	AS-21
Piston and Connecting Rod Assembly	AS-7
Install.....	AS-7
Piston Cooling Nozzle	AS-12
Install.....	AS-12
Push Rods or Tubes	AS-64
Install.....	AS-64
Rocker Lever	AS-65
Install.....	AS-65
Rocker Lever Cover	AS-66
Install.....	AS-66
Rocker Lever Housing	AS-65
Install.....	AS-65
Sea Water Pump Pulley	AS-98
Install.....	AS-98
Starting Motor	AS-89
Install.....	AS-89
Tappet	AS-16
Install.....	AS-16
Turbocharger	AS-85
Install.....	AS-85
Turbocharger Oil Drain Line	AS-86
Install.....	AS-86
Turbocharger Oil Supply Line	AS-87
Install.....	AS-87
Vibration Damper, Rubber	AS-61
Install.....	AS-61
Vibration Damper, Viscous	AS-61
Install.....	AS-61
Water Inlet Connection	AS-62
Install.....	AS-62
Water Pump	AS-63
Install.....	AS-63

This Page Left Intentionally Blank

Camshaft Bushings (001-010)

Install

Mark the camshaft bushing and cylinder block so you can align the lubricating oil hole in the cylinder block with the large lubricating oil hole in the bushing.

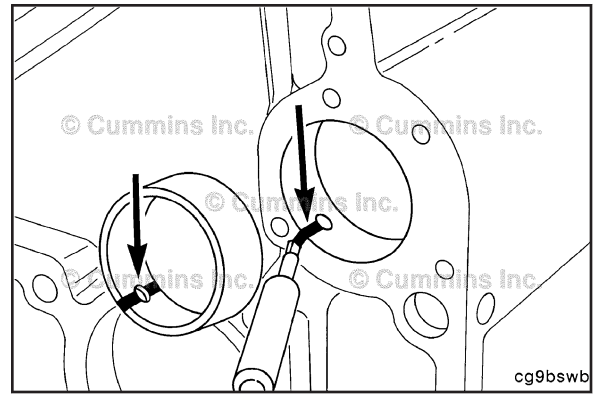

Slide the camshaft bushing on the replacer tool. Align the marks on the camshaft bushing and the cylinder block.

Drive the camshaft bushing to the correct installed depth. The correct installed depth is when the camshaft bushing end is flush with the machined face of the block and the oil hole aligns with the cylinder block oil hole.

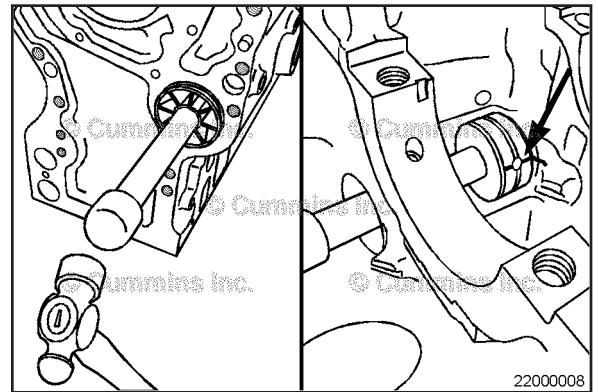

Be sure the large lubricating oil hole is aligned.

A 3.2 mm [0.128 in] diameter rod **must** be able to pass through the lubricating oil hole.

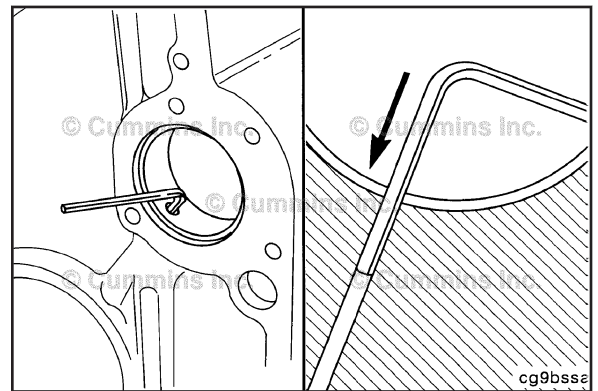

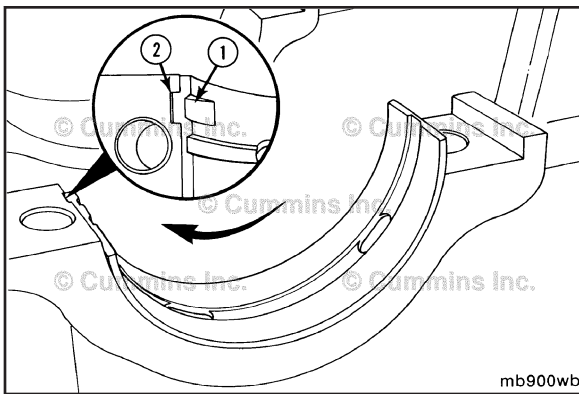

Crankshaft (001-016)

Install

⚠CAUTION⚠

The tang (1) on the bearing shell must be in the slot (2) of the bearing saddle to correctly position the bearing and prevent engine damage.

Upper Main Bearings.

Make sure the backs of the bearings are clean and free of debris before installing the upper main bearings into the block.

Do **not** lubricate the side of the main bearing that is against the cylinder block.

Apply a coat of assembly lubricant, Part Number 3163087 or equivalent, to the crankshaft side of the upper main bearings.

NOTE: Make sure the main bearing being installed is the same size as the main bearing that was removed. The size is engraved on the back of the main bearing.

NOTE: The upper and lower main bearing shells of some engines are **not** interchangeable. The backs of the main bearings are marked with the proper orientation, if required.

NOTE: If used bearing shells are to be installed, they **must** be installed in their original locations, as marked during disassembly.

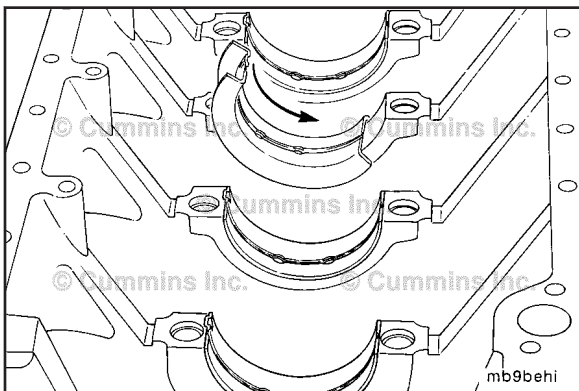

Install the upper crankshaft thrust bearing.

4 cylinder engines - The number 4 main bearing position.

6 cylinder engines - The number 6 main bearing position.

⚠ WARNING ⚠

This component or assembly weighs greater than 23 kg [50 lb]. To prevent serious personal injury, be sure to have assistance or use appropriate lifting equipment to lift this component or assembly.

⚠ WARNING ⚠

Carefully install the crankshaft to avoid damage to the crankshaft main bearings, especially the thrust/main bearing journals. Engine life will be shortened if damage to the crankshaft occurs.

Use a hoist and nylon list sling, Part Number 3375957.

For 6 cylinder engines, Install the sling around the number 3 and number 4 connecting rod bearing journals.

For 4 cylinder engines, Install the sling around the number 2 and number 3 connecting rod bearing journals.

Install the crankshaft.

NOTE: Lower the crankshaft straight down to avoid damage to the crankshaft and cylinder block.

NOTE: When setting the crankshaft into the block, make sure the front crankshaft gear meshes with the lubricating oil pump gear, if **not** previously removed.

Check the main bearing caps to make sure the ring dowels are installed.

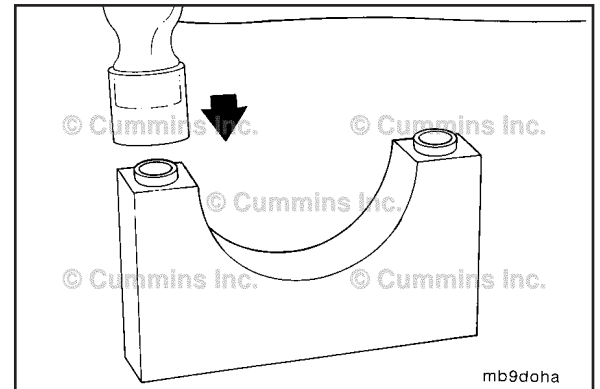
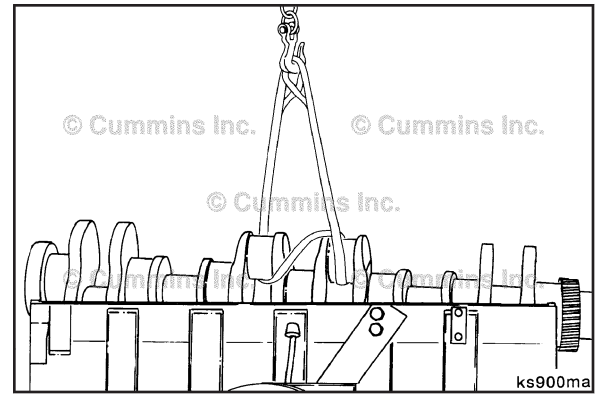

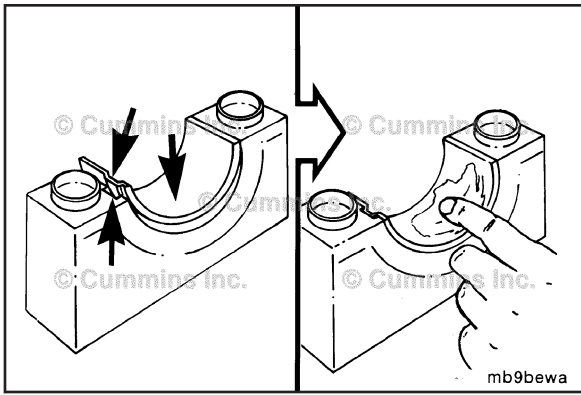

CAUTION

Do not lubricate the back side of the bearing that contacts the main bearing cap.



Make sure the backside of the bearings are clean and free of debris before installing the lower main bearings into the main bearing caps.

Make sure to align the tang of the bearings with the recesses on the main bearing caps.

NOTE: Some engines use a thrust bearing for the upper and lower main bearing (360 degree), while other engines only have a thrust bearing for the upper main bearing (180 degree). **Always** use replacement bearings of the same design.

If equipped, install the lower crankshaft thrust bearing.

4 cylinder engines - The number 4 main bearing position.

6 cylinder engines - The number 6 main bearing position.

Apply a coat of assembly lube, Part Number 3163087, to the crankshaft side of the main bearings and thrust bearing surfaces.

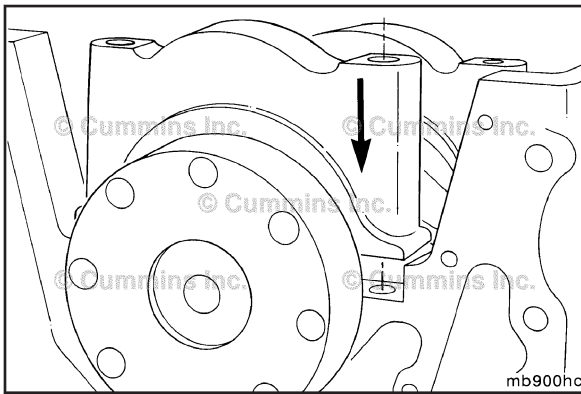

Make sure the main bearing cap surfaces between the main bearing cap and block are clean and free of debris.

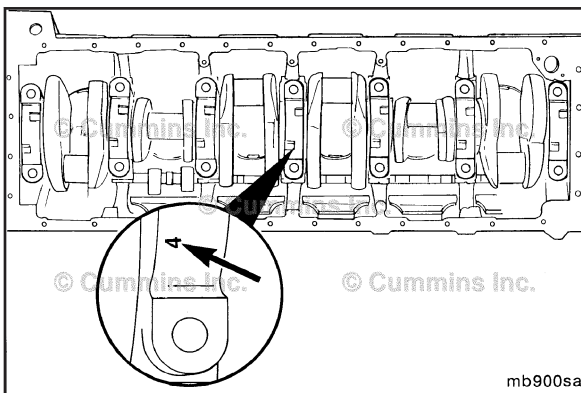

The main bearing caps are/were numbered during the removal process for their location. Number 1 starts with the front of the block.

NOTE: The caps **must** be installed so the numbers on the caps match the bearing saddle in the block. The lock tangs in the main bearing saddle and bearing cap **must** be on the same side.

Install the main bearing caps. Make sure to align the ring dowels on the main bearing cap with the corresponding drillings in the cylinder block.

Lubricate the main bearing capscrew threads and underside of the head with clean engine oil.

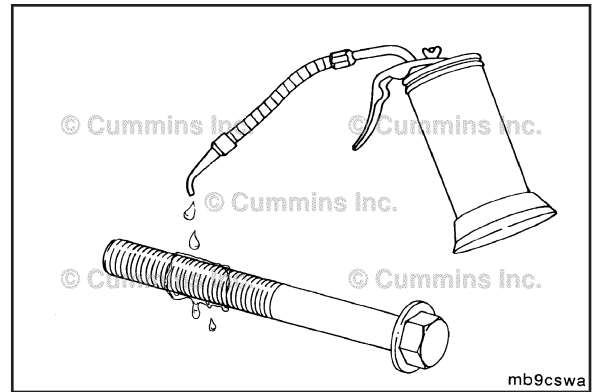

Gently tap the main bearing cap into position with a plastic or rubber mallet.

When seated, install the main bearing capscrews and tighten.

Torque Value: 50 N·m [37 ft-lb]

Do **not** tighten to the final torque value at this time. Final torque should be applied after all main bearing caps are installed.

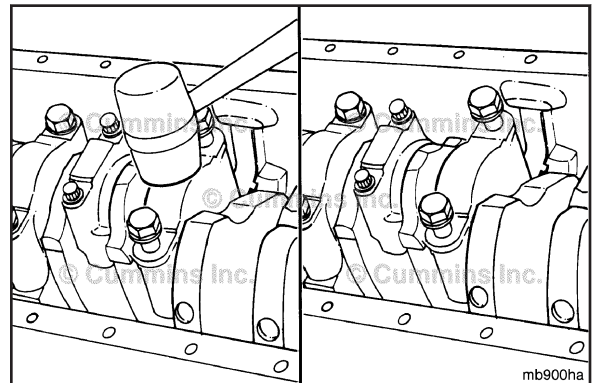

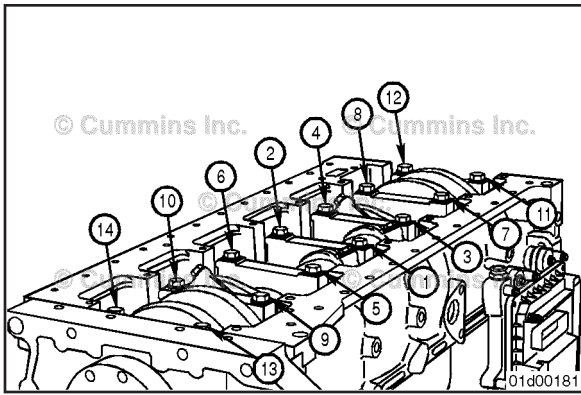

NOTE: The sequence to the right is for a 6 cylinder engine. For a 4 cylinder engine, use the same sequence for the 5 main bearing caps.



Tighten the capscrews evenly and in sequence. Perform each step to all capscrews before performing the next step.

3.9L and 5.9L Engines:

Torque Value:

Step 1	50 N•m	[37 ft-lb]
Step 2	80 N•m	[59 ft-lb]
Step 3	Turn all capscrews through 90 degrees.	

⚠CAUTION⚠

For 4.5L and 6.7L engines, there is a different torque procedure for new and previously installed main bearing capscrews. Failure to use the correct torque value can result in engine damage.

4.5L and 6.7L Engines:

Torque Value:

Previously Installed Main Bearing Capscrews

Step 1	50 mm	[37 in]
Step 2	60 N•m	[44 ft-lb]
Step 3	80 N•m	[59 ft-lb]
Step 4	Rotate 90 degrees.	

Torque Value:

New Main Bearing Capscrews

Step 1	50 N•m	[37 ft-lb]
Step 2	60 N•m	[44 ft-lb]
Step 3	80 N•m	[59 ft-lb]
Step 4	Rotate 90 degrees.	
Step 5	120 mm	[89 in]
Step 6	Loosen completely	
Step 7	60 mm	[44 in]
Step 8	85 mm	[63 in]
Step 9	Rotate 120 degrees.	

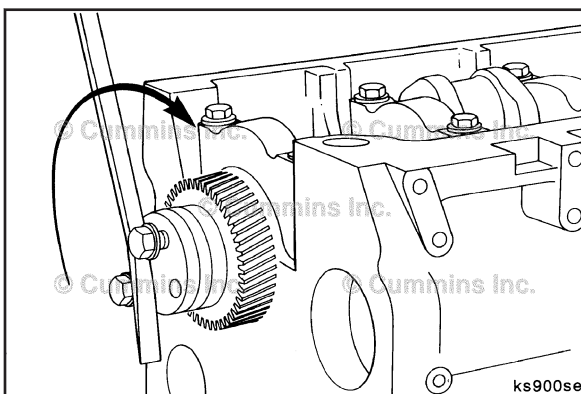

The crankshaft **must** rotate freely after installing the main bearing caps.

If the crankshaft does **not** rotate freely:

- 1 Check if the crankshaft is contacting one of the connecting rods
- 2 Check if the correct main bearing caps were installed correctly
- 3 Check if the main bearing cap ring dowels or mounting surfaces were damaged during installation
- 4 Check if the correct main bearings were installed.

NOTE: The dimensions of the thrust bearing and crankshaft journal determine end clearance.

Measure the crankshaft end clearance with a dial indicator assembly, Part Number 3824564 and magnetic base, Part Number 3377399.

Crankshaft End Clearance

mm		in
0.102	MIN	0.004
0.432	MAX	0.017

If the crankshaft end clearance is **not** within specification:

- 1 If the crankshaft end clearance is below specification, check if there are any obstructions limiting the crankshaft's travel (lubricating oil pump, connecting rod, etc.)
- 2 If the crankshaft end clearance is above specification, inspect the crankshaft thrust bearing surface. Also check if the correct thrust bearing(s) were installed.

NOTE: Oversize thrust bearings are available if the end clearance is **not** within specifications. Oversize thrust bearings of 0.25 to 0.51 mm [0.010 to 0.020 in] are available.

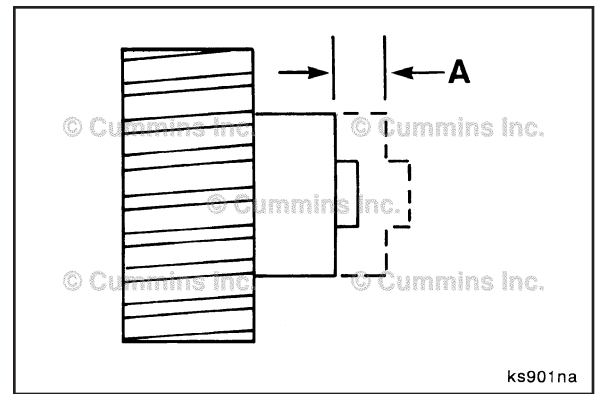
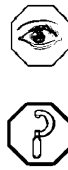

ks901na

Piston and Connecting Rod Assembly (001-054)



Install

The cylinder block and all parts **must** be clean before assembly. Refer to Procedure 001-026 to inspect the cylinder walls of the cylinder block.

Use a clean, lint-free cloth to clean the connecting rods and bearing shells.

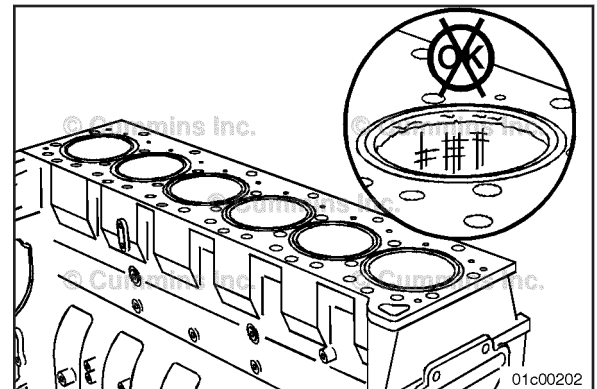

01c00202

If new bearings are **not** used, the used bearings **must** be installed on the same connecting rod and location from where they were removed.



Make sure the connecting rod and backside of the connecting rod bearing surfaces are clean and free of debris. Do **not** lubricate the backside of the connecting rod bearings.



Install the upper bearing shell into the connecting rod.

The tang of the bearing shell **must** be in the slot of the rod. The end of the bearing shell **must** be even with the cap mounting surface.

The upper and lower rod bearing shells are **not** interchangeable on fracture split connecting rods.

NOTE: If the connecting rod bushing is removed for any reason, a new bushing **must** be used.

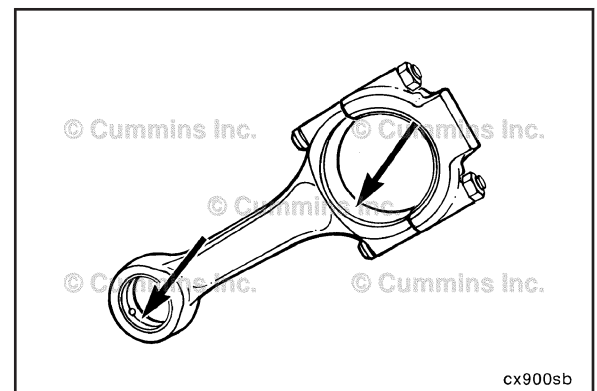

cx900sb

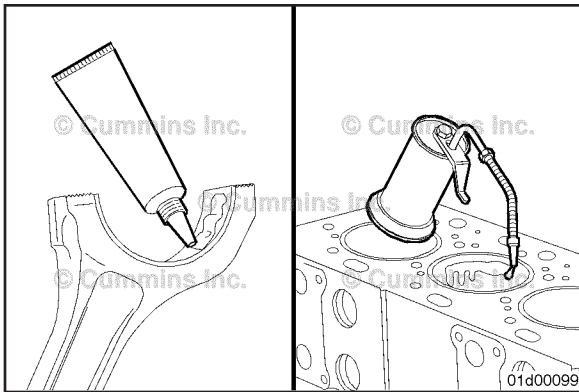

Use assembly lube, Part Number 3163087, or equivalent, to coat the inside circumference of the bearing shell.
Apply a film of clean 15W-40 oil to the cylinder block wall.

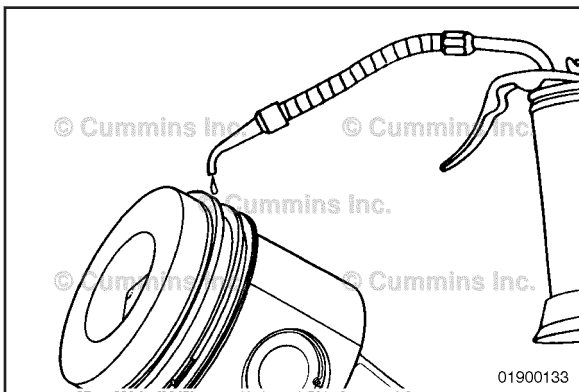

Lubricate the rings and piston skirts with clean engine lubricating oil.

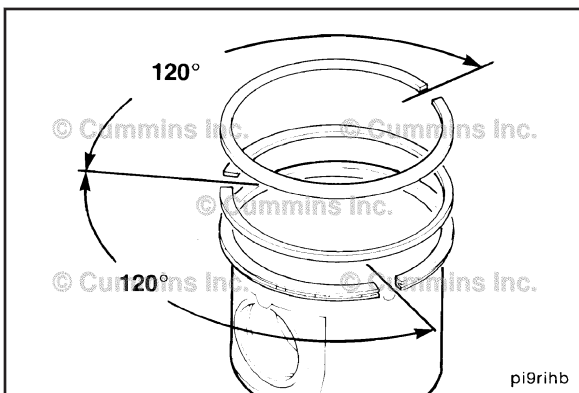

Rotate the rings to position the ring gaps as shown.

The ring gap of each ring **must not** be aligned with the piston pin, or with any other ring. If the ring gaps are **not** aligned correctly, the rings will **not** seal properly.

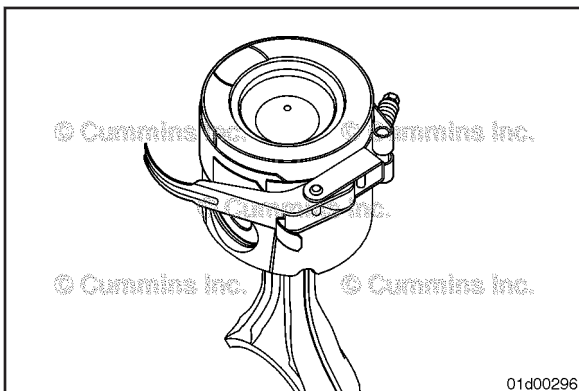

For 3.9 L and 5.9 L engines, use piston ring compressor, Part Number 3164330, to compress the rings.
For 4.5 L and 6.7 L engines, use piston ring compressor, Part Number 4918294, to compress the rings.

Rotate the crankshaft so the connecting rod journal of the connecting rod being installed is at bottom dead center.

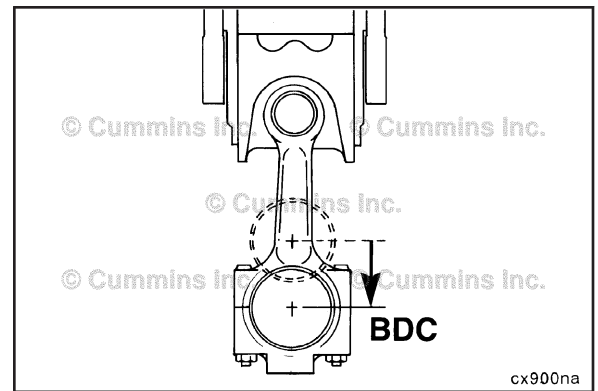

⚠CAUTION⚠

Failure to follow this step will result in extensive engine damage.

3.9 L and 5.9 L Engines

NOTE: The piston and connecting rod assembly **must** be installed with the correct orientation. The orientation of the piston and connecting rod assembly for 4.5 L and 6.7 L engines is different than 3.9 L and 5.9 L engines covered by this manual.

Align the "Front" marking and/or arrow on the top of the piston so that it points towards the front of the engine. Insert the connecting rod through the cylinder bore until the ring compressor contacts the top of the cylinder block.

The long end of the connecting rod (1) will be on the intake side of the engine. If **not**, verify the piston is installed correctly onto the connecting rod.

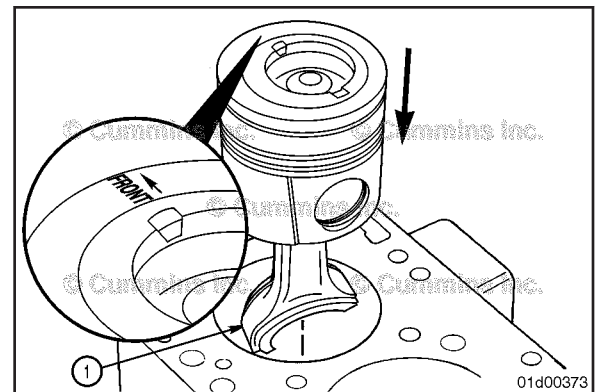

⚠CAUTION⚠

Failure to follow this step will result in extensive engine damage.

4.5 L and 6.7 L Engines

NOTE: The piston and connecting rod assembly **must** be installed with the correct orientation. The orientation of the piston and connecting rod assembly for 4.5 L and 6.7 L engines is different than 3.9 L and 5.9 L engines covered by this manual.

Align the "Front" marking and/or arrow on the top of the piston so that it points towards the front of the engine. Insert the connecting rod through the cylinder bore until the ring compressor contacts the top of the cylinder block.

The long end of the connecting rod (1) and the notch in the piston skirt (2) will be on the exhaust side of the engine. If **not**, verify the piston is installed correctly onto the connecting rod.

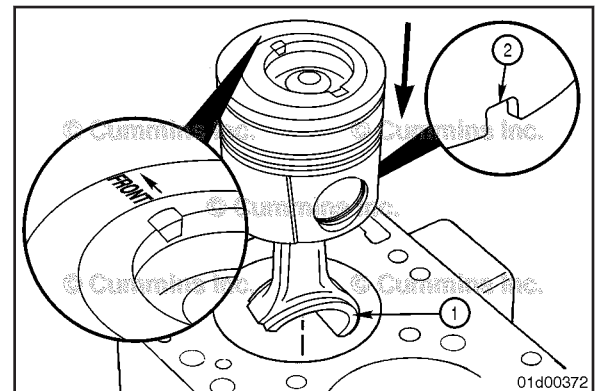

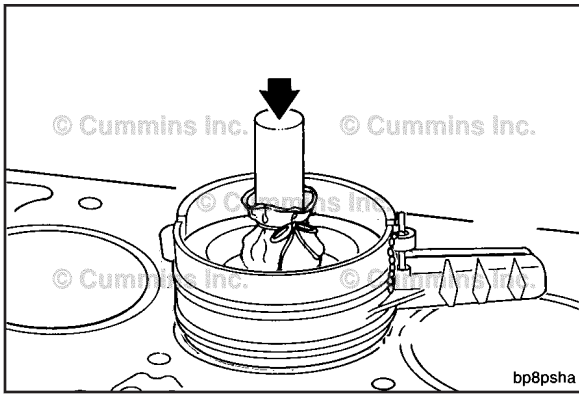

Hold the ring compressor against the cylinder block.

Push the piston through the ring compressor and into the cylinder bore.

Push the piston until the top ring is completely in the cylinder bore.

NOTE: If the piston does **not** move freely, remove the piston and inspect for broken or damaged rings.

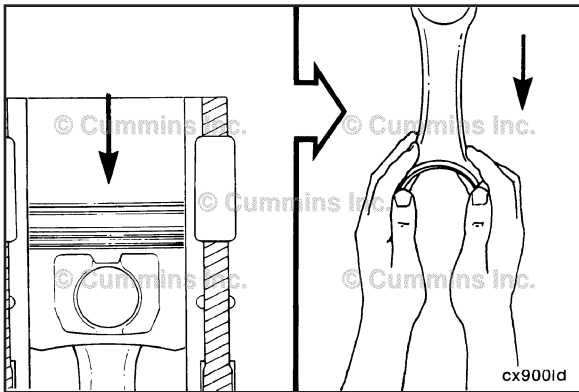

Carefully push the piston into the bore while guiding the connecting rod to the crankshaft journal.

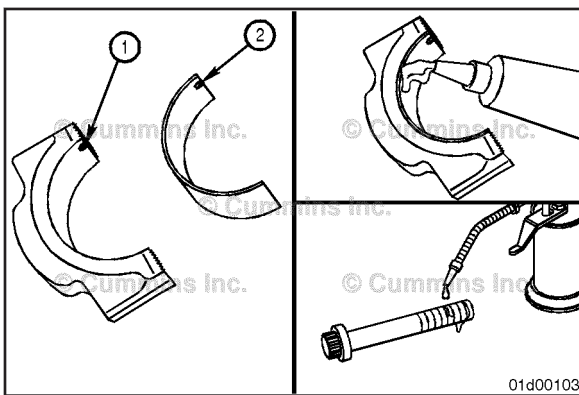

NOTE: If new bearings are **not** used, the used bearings **must** be installed on the same connecting rod cap from which they were removed.



Install the bearing in the connecting rod cap.

The tang of the bearing (2) **must** be in the slot of the cap (1).

Use assembly lube, Part Number 3163087, or equivalent, to coat the inside diameter of the bearing shell.

Use clean 15W-40 oil to lubricate the connecting rod cap screw threads and the underside of the connecting rod cap screw threads.

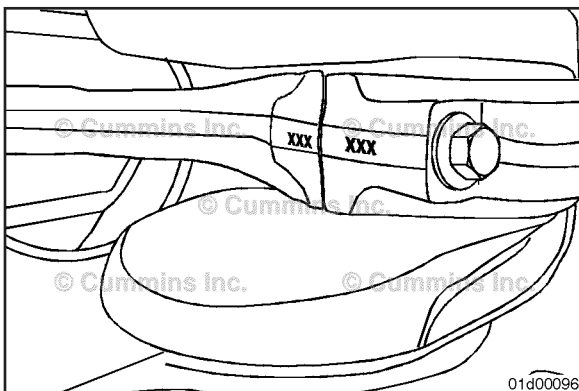

CAUTION

Do not damage the fractured split surface on the connecting rod or connecting rod cap while the connecting rod cap is removed. If the fractured split surface is damaged, the connecting rod and connecting rod cap **must** be replaced to help reduce the possibility of engine damage.



The connecting rod and cap **must** have the same number and **must** be installed in the proper cylinder. The connecting rod cap number and rod number **must** be on the same side of the connecting rod to prevent engine damage during engine operation.

Install the connecting rod cap and cap screws.

Use a marked socket and torque wrench to tighten the rod capscrews.



Using the torque plus angle method, tighten the connecting rod capscrews in alternating sequence.

Torque Value:

- Step 1 30 N•m [22 ft-lb]
- Step 2 60 N•m [44 ft-lb]
- Step 3 Rotate 60 degrees clockwise

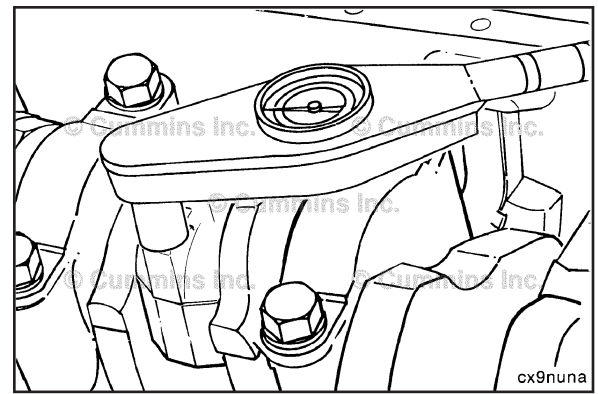

Do **not** measure the clearance between the rod cap and crankshaft.



Measure the side clearance between the connecting rod and crankshaft.

Connecting Rod and Crankshaft Side Clearance

mm		in
0.10	MIN	0.004
0.33	MAX	0.013

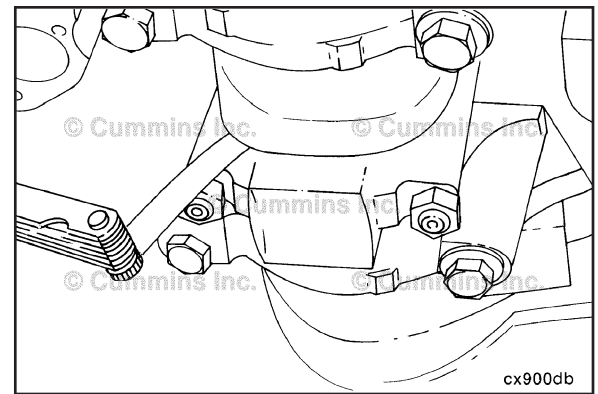

Measure piston protrusion above the cylinder block combustion deck.



NOTE: This procedure is only required after a piston, crankshaft, connecting rod, or block modification/replacement.

For 3.9 L and 5.9 L engines, Refer to Procedure 002-021. This procedure will determine the correct grade of head gasket to install.

For 4.5 L and 6.7 L engines, measure the piston protrusion using depth gauge assembly Part Number 3823495. No piston or head gasket grading is required.

Install the dial indicator on the cylinder head and zero.

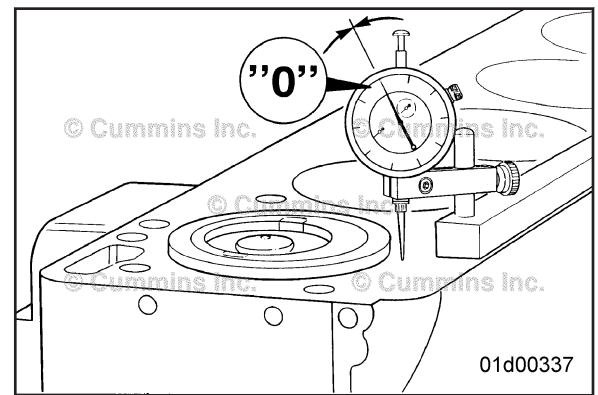

Move the dial indicator directly over the piston pin to eliminate any side-to-side movement. Do **not** place the indicator tip on the anodized area.

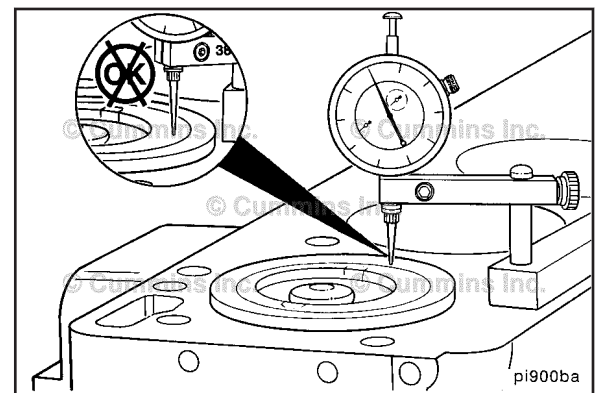

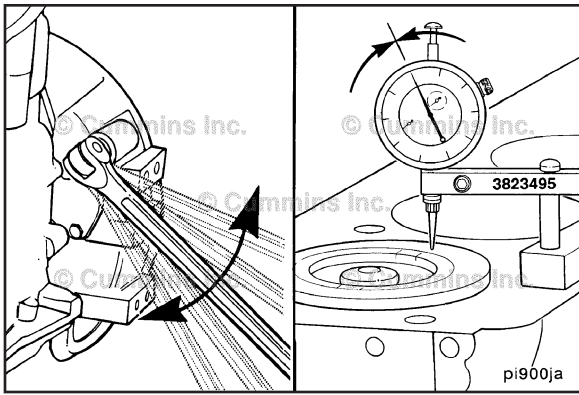

Rotate the crankshaft to top dead center. Rotate the crankshaft clockwise and counterclockwise to find the highest dial indicator reading. Record the reading.

Piston Protrusion

mm		in
0.151	MIN	0.006
0.485	MAX	0.019

If the piston protrusion is **not** within specification, verify that the correct parts are installed and/or the cylinder block combustion deck has been machined improperly. Refer to Procedure 001-026

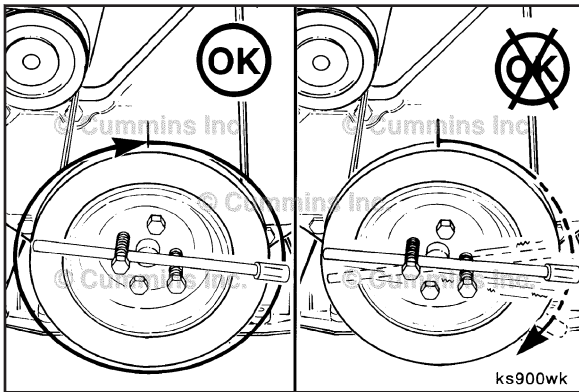

Check for freedom of rotation as the connecting rod caps are installed. If the crankshaft does **not** rotate freely, check the installation of the connecting rod bearings and the bearing size.

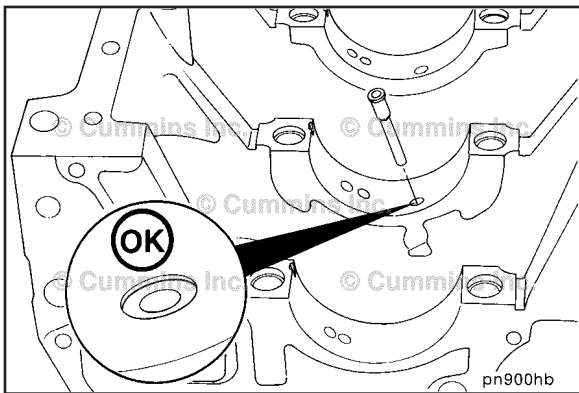

Piston Cooling Nozzle (001-046) Install

⚠CAUTION⚠

Do not use a hammer to install the piston cooling nozzles. Use hand pressure only. Using a hammer can cause component damage.

Push the piston cooling nozzle or plug into place by hand. Use a flat punch to push the nozzle or plug into the recess.

NOTE: Blocks using saddle jet piston cooling nozzles may be machined for J-jet piston cooling nozzles as well. If this is the case, capscrews will be installed in the J-jet piston cooling nozzle location. If previously removed, follow the J-jet piston cooling nozzle installation procedure later in this procedure.

⚠ CAUTION ⚠

Slight bending of the piston cooling nozzles can result in severe engine damage. Replace piston cooling nozzle if it is bent or damaged during disassembly or assembly.

Install the piston cooling nozzle and/or capscrew one cylinder at a time rotating the crankshaft as necessary for access.

Use a long extension to guide the capscrew and/or piston cooling nozzle into place.

NOTE: The locator pin on the J-jet piston cooling nozzle **must** engage the locating hole in the block for proper alignment.

Tighten the capscrew.

Torque Value:

J-Jet Capscrew

Step 1 15 N•m [133 in-lb]

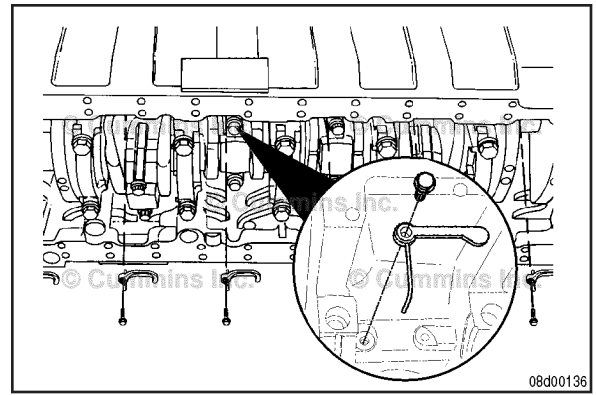

Gear Housing, Rear (001-034)

Install

⚠ CAUTION ⚠

Make sure to only apply sealant to the areas specified. Failure to do so may block oil passages to the accessory drive and/or cause a loss of oil pressure. This will result in severe engine damage.

Apply a 1.5 to 2.0 mm [0.06 to 0.08 in] wide bead of sealant, Part Number 3164070, to the block side of the gear housing in the path illustrated and install the rear gear housing capscrews and housing.

Be sure there is a bead of sealant at the intersection joint of the cylinder block, oil pan, and gear housing.

NOTE: Install the gear housing within 10 minutes of applying sealant or the sealant will **not** seal correctly. Once installed, allow the sealant to dry for 30 minutes before running the engine.

Tighten the capscrews as shown.

Torque Value:

M12

Step 1 50 N•m [37 ft-lb]

Torque Value:

M10

Step 1 47 N•m [35 ft-lb]

Torque Value:

M8

Step 1 24 N•m [212 in-lb]

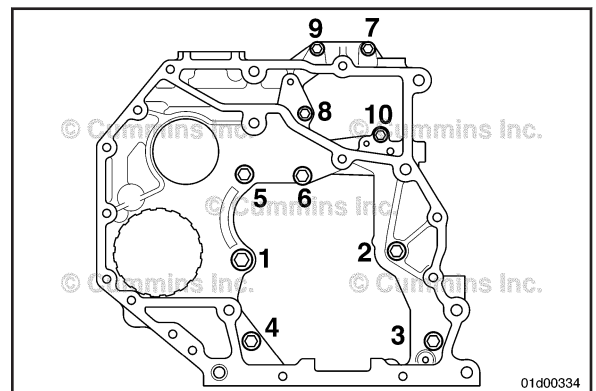
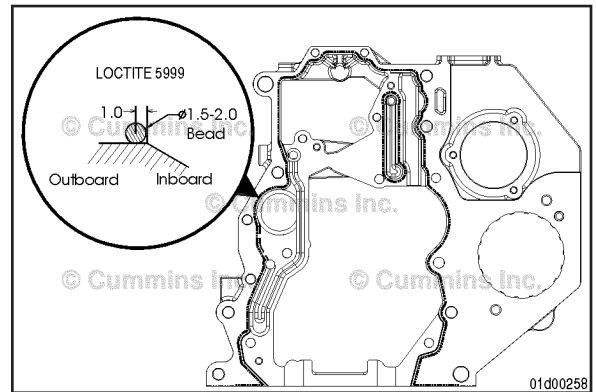

Gear Housing, Front (001-033)

Install

For engines equipped with a paper gasket style oil pan, inspect the oil pan gasket for damage.

NOTE: If the engine is equipped with a suspended oil pan with a rubber oil pan gasket and the gasket is found to be damaged, the oil pan **must** be removed and the entire oil pan gasket replaced. Refer to Procedure Procedure 007-025. If the engine used sealant only between the gear housing and the oil pan, remove the old sealant and apply new sealant, Part Number 3164070, to the oil pan mounting flange.

If the pan gasket is torn, it can be repaired.

Cut the torn gasket off even with the front of the cylinder block.

Using the old gasket as a pattern, cut the front section of a new gasket to the same size.

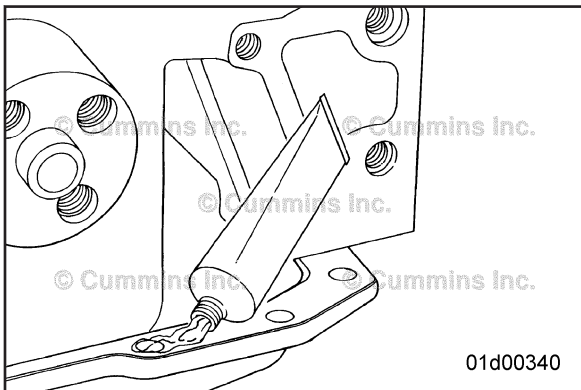
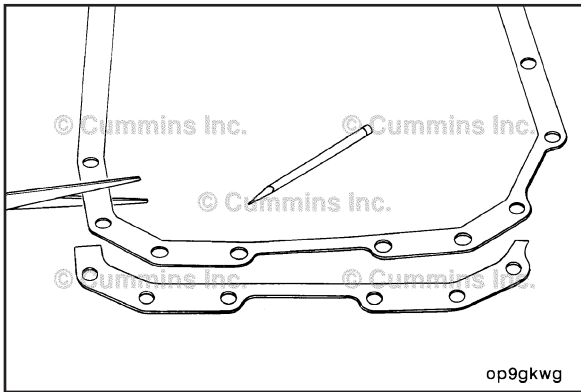
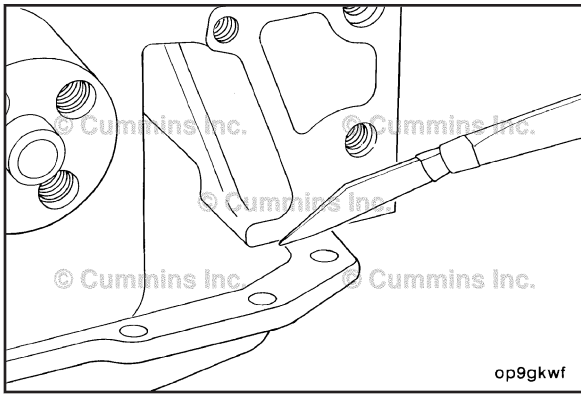

NOTE: The gear housing must be installed within 10 minutes of applying the sealant.

Clean the sealing surfaces.

Coat the new gasket on both sides with sealant, Part Number 3164067.

Be sure there is a bead of sealant at the intersecting joint of the cylinder block, oil pan, and gear housing.

Use common thread or very fine wire to hold the new gasket splice in position as illustrated.

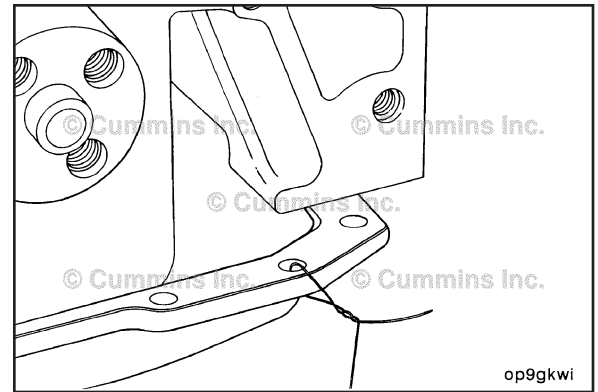

Check the fit of the new gear housing to cylinder block gasket. It may be necessary to trim the bottom edges of the gasket before installation.



NOTE: When properly trimmed, the gear housing gasket **must** be even with the lubricating oil pan gasket when installed.

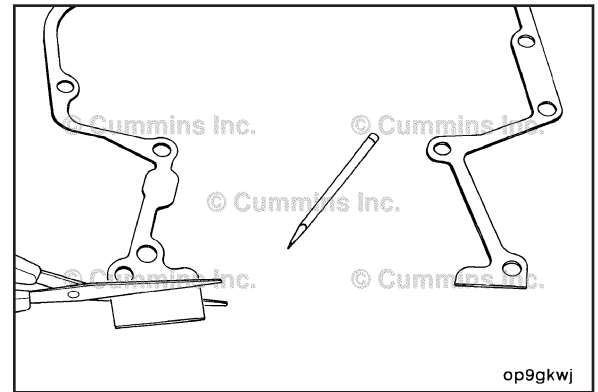

Position the gasket on the alignment dowels.

Use guide pins, M8 x 1.25 x 50, to assist in aligning the gasket and gear housing. Make sure to remove the guide pins after alignment.

Apply a bead of sealant, Part Number 3164067, at the intersecting joint of the cylinder block, oil pan, and gear housing.

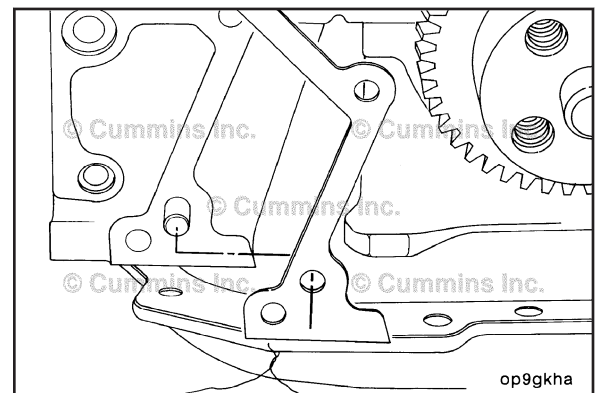

Carefully install the gear housing.

Make sure the gasket is still in place.

NOTE: Locations numbered 1, 2, 3, 4, and 5 in the illustration use internal torx fasteners. Make sure to install the correct fasteners in the correct location.

Install and tighten the mounting capscrews in the defined order.

Torque Value: 24 N•m [18 ft-lb]

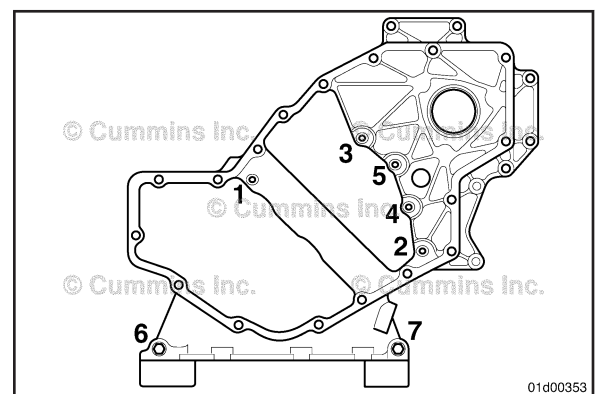

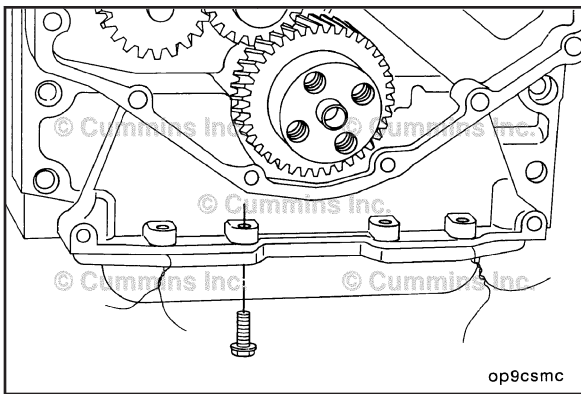

Start the oil pan capscrews into the holes **not** being used to tie the gasket in place.

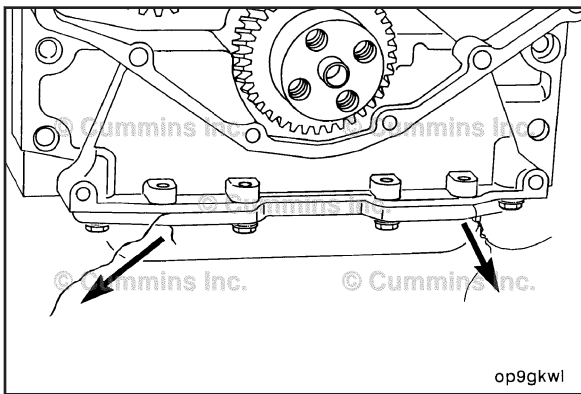

Remove the thread or wire holding the gasket in place.

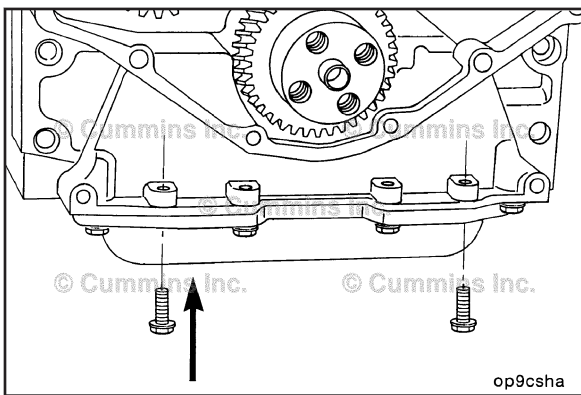

Install the remaining two capscrews.

Tighten the capscrews.

Torque Value: 24 N•m [18 ft-lb]

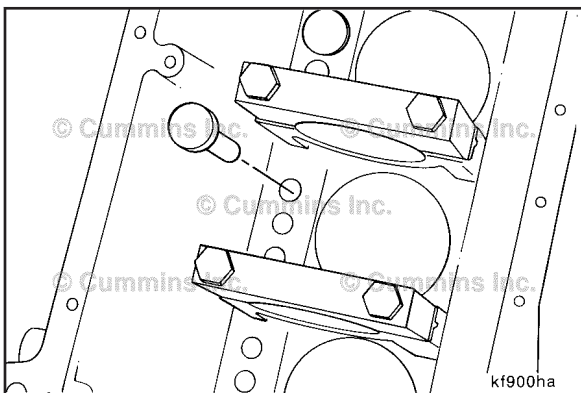

Tappet (004-015)

Install



Lubricate the tappets with assembly lubricant, Part Number 3163087, or equivalent.

Prior to installing the camshaft, install the tappets through the bottom of the engine.

If reusing the tappets, the tappets **must** be installed in the same location in which the tappets were removed.

NOTE: Anytime new tappets are used, the push rods **must** be replaced as well.

Camshaft (001-008)

Install

Rear Gear Train

Apply assembly lubricant, Part Number 3163087, to the rear camshaft bore.

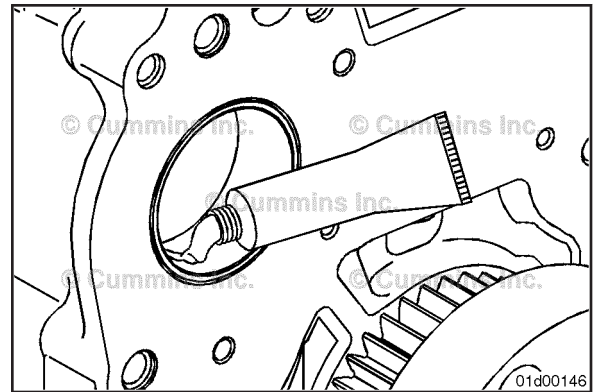

Lubricate the camshaft lobes, journals, and thrust washer with assembly lubricant, Part Number 3163087.

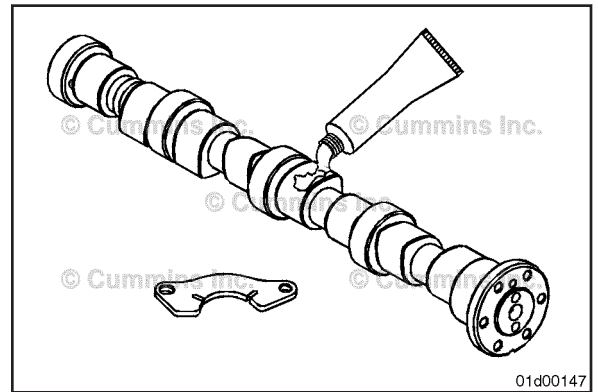

Use a gear puller, Part Number ST647, or equivalent, to attach to the end of the camshaft where the camshaft gear mounts, to act as a handle. This will give proper leverage and simplicity of installation of the camshaft.

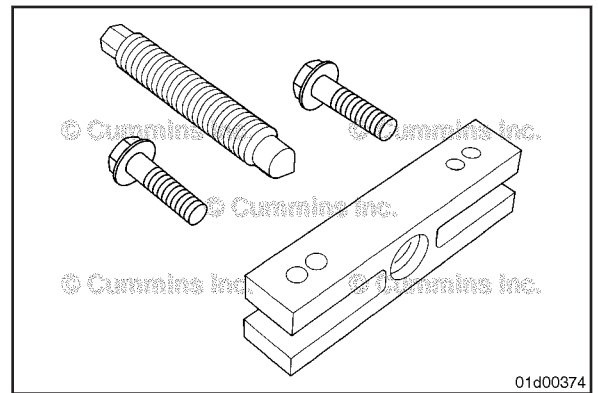

⚠ CAUTION ⚠

Before the camshaft is installed, verify the tappets are fully inserted into the tappet bores. If the tappets are not fully inserted, the camshaft and/or tappets may be damaged during installation.

NOTE: The following illustrations show the engine in the upright position for clarity.

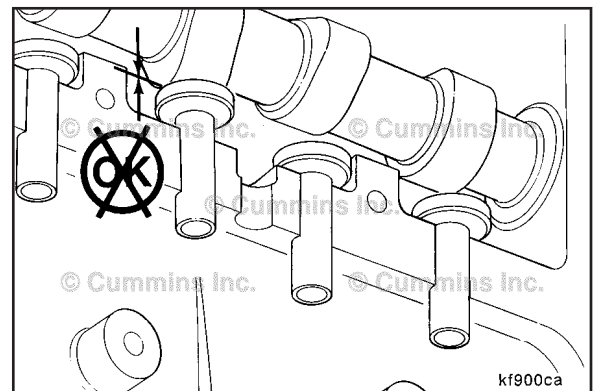

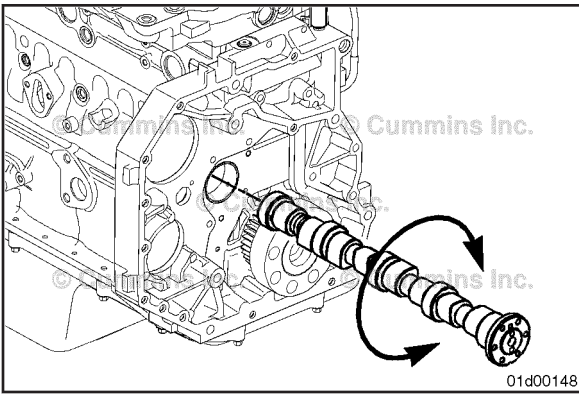

CAUTION

Do not force the camshaft into the camshaft bore as damage to the camshaft bushing can result.

Install the camshaft. While pushing in slightly, rotate the camshaft and carefully work the camshaft through the camshaft bushings. As each camshaft journal passes through a bushing, the camshaft will drop slightly and the camshaft lobes will catch on the bushings. Rotating the camshaft will free the lobe from the bushing and allow the camshaft installation to continue.

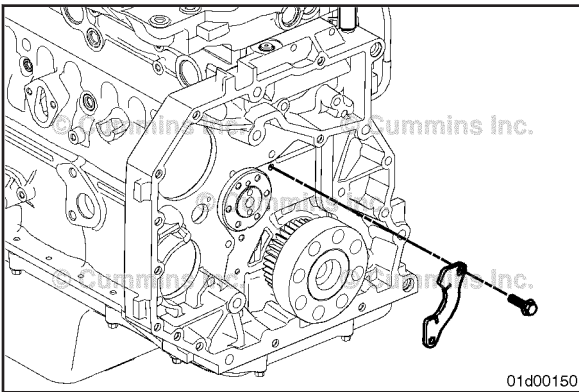

Install the thrust plate.

Torque Value: 24 N•m [212 in-lb]

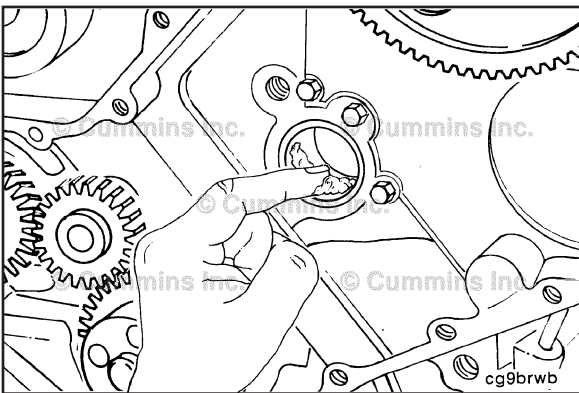

Front Gear Train

Apply assembly lubricant, Part Number 3163087, to the front camshaft bore.

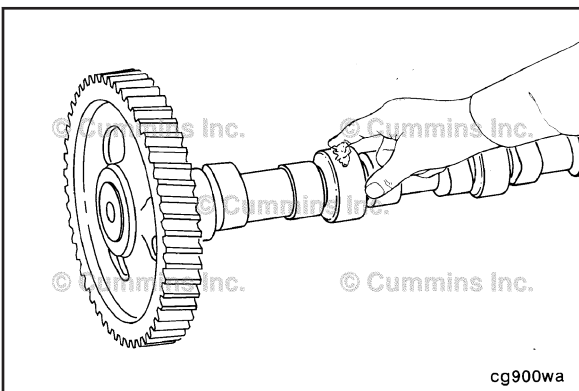

Lubricate the camshaft lobes, journals, and thrust plate with assembly lubricant, Part Number 3163087.

⚠ CAUTION ⚠

Before the camshaft is installed, verify the tappets are fully inserted into the tappet bores. If the tappets are not fully inserted, the camshaft and/or tappets may be damaged during installation.

NOTE: The following illustrations show the engine in the upright position for clarity.

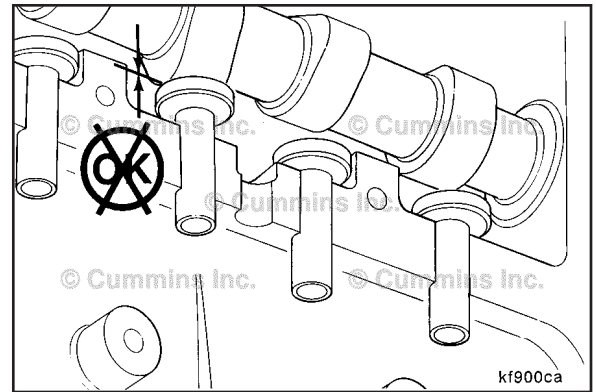

⚠ CAUTION ⚠

Do not try to force the camshaft into the camshaft bore as damage to the camshaft bushing can result.

Install the camshaft. While pushing in slightly, rotate the camshaft and carefully work the camshaft through the camshaft bushings. As each camshaft journal passes through a bushing, the camshaft will drop slightly and the camshaft lobes will catch on the bushings. Rotating the camshaft will free the lobe from the bushing and allow the camshaft installation to continue.

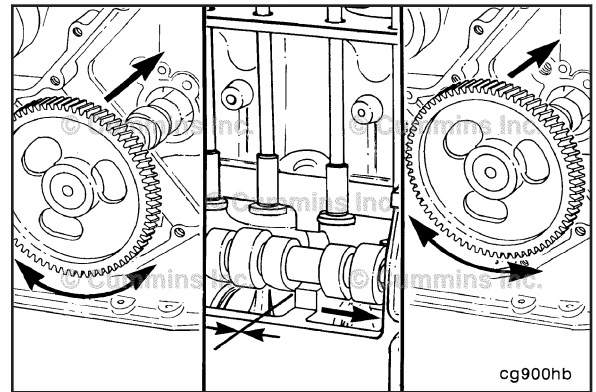

⚠ CAUTION ⚠

To reduce the possibility of engine damage, make sure the camshaft rotates freely.

Before the camshaft gear engages the crankshaft gear, check the camshaft for ease of rotation. When installed properly, the camshaft **must** rotate freely.

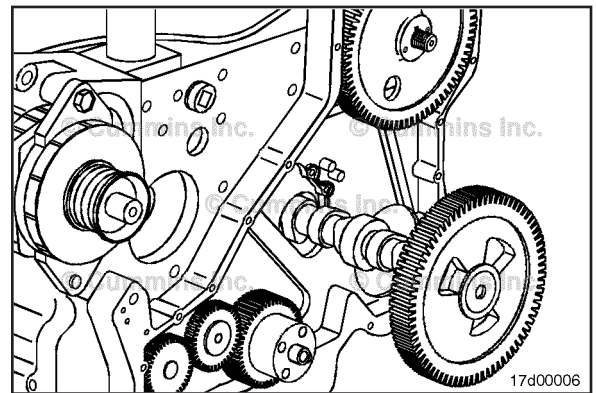

Align the timing marks as illustrated and install the camshaft.

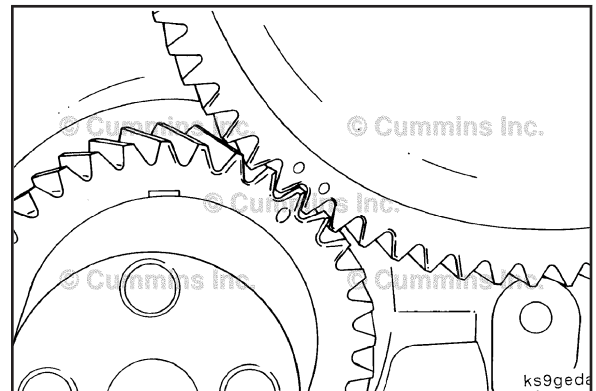

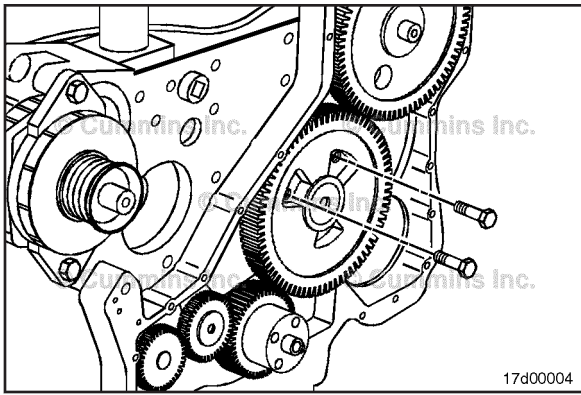

Install the thrust plate capscrews.

Torque Value: 24 N•m [212 in-lb]

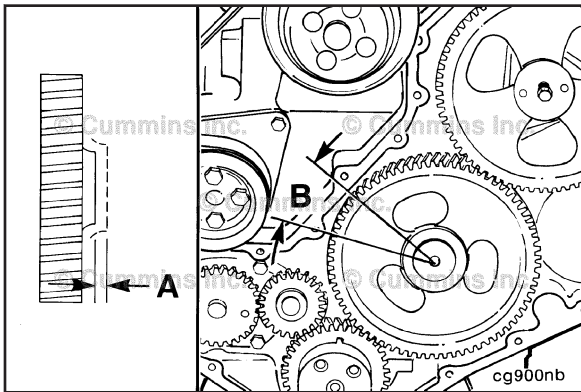

Use gauge, Part Number 3824564, and magnetic base, Part Number 3377399, to verify that the camshaft has proper backlash and end play.

Camshaft End Play (A)

mm		in
0.12	MIN	0.005
0.50	MAX	0.020

Camshaft Gear Backlash Limits (B)

mm		in
0.08	MIN	0.003
0.25	MAX	0.010

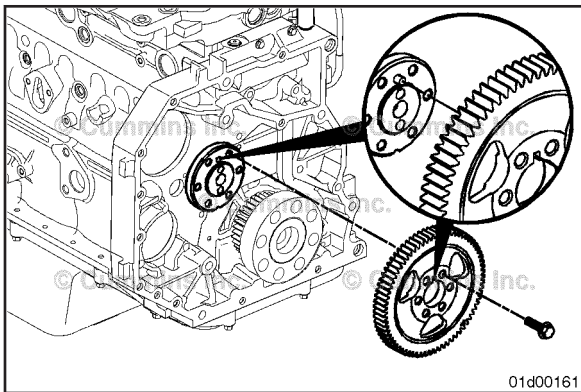

**Camshaft Gear (Camshaft Installed)
(001-012)**

Install

⚠CAUTION⚠

To reduce the possibility of engine damage, make sure the camshaft rotates freely.

Align the camshaft gear with the pin in the camshaft and the mark on the crankshaft gear.

Install camshaft gear onto the camshaft.

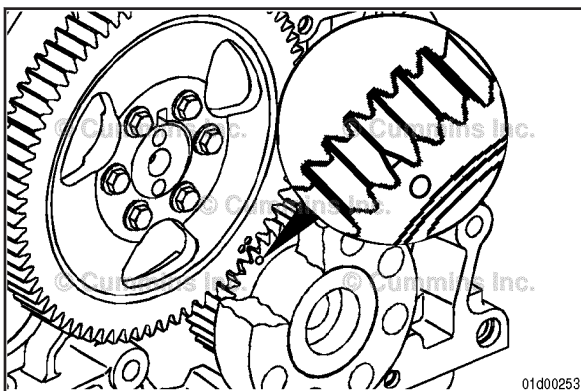

Check to make sure the timing marks on the camshaft gear align with the timing marks on the crankshaft gear. If equipped with an air compressor, make sure to align the line that was scribed on the camshaft gear and air compressor gear during the camshaft gear removal step. Refer to Procedure 012-014 in Section 12.



NOTE: The engine can have a mark on the crankshaft gear or chamfered tooth.

Install the camshaft gear capscrews and tighten.

Torque Value: 36 N•m [27 ft-lb]

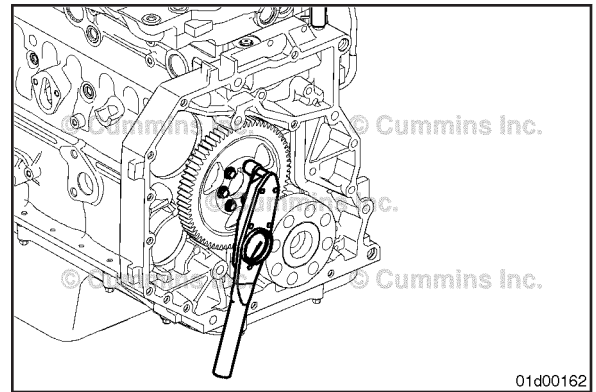

Block Stiffener Plate (001-089)

Install

NOTE: The block stiffener plate **must** be installed so that the center ribs are bent away from the block, to ensure proper clearance from the block main caps.

NOTE: Some 6 cylinder engines use a 4 cylinder block stiffener plate. When installing the block stiffener plate, make sure it is centered on the block.

NOTE: For some oil pan/oil suction tube configurations, one of the block stiffener mounting capscrews may be different than the rest. This capscrew, with a lower head profile, should be installed in the opening adjacent to the oil suction tube mounting location. The low profile capscrew ensures in some applications that there is sufficient clearance between the oil suction tube and the block stiffener mounting capscrew.

Install the block stiffener plate so that the exterior portion of the block stiffener plate with the recess is next to the oil suction tube mounting location at the front of the engine.

Install the block stiffener plate mounting capscrews.

Torque Value:

Block Stiffener Plate Capscrews

Step 1 43 N•m [32 ft-lb]

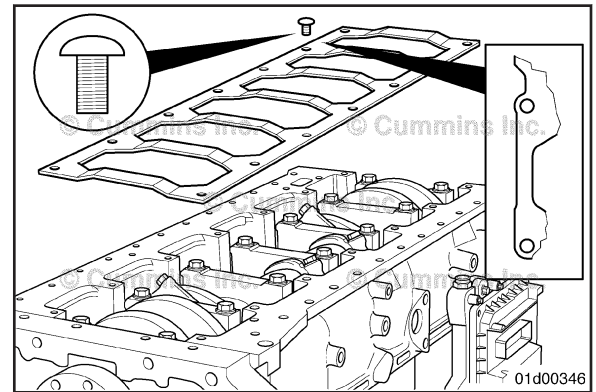

Lubricating Oil Suction Tube (Block-Mounted) (007-035)

Install

⚠ CAUTION ⚠

The suction tube gasket is not symmetrical. Failure to install it properly can result in low oil pressure and engine damage.

Install the lubricating oil suction tube gasket and suction tube.

Install and tighten the suction tube mounting capscrews.

Torque Value: 24 N•m [212 in-lb]

NOTE: Take care to ensure the oil suction tube gasket openings align with both the oil suction tube and the block.

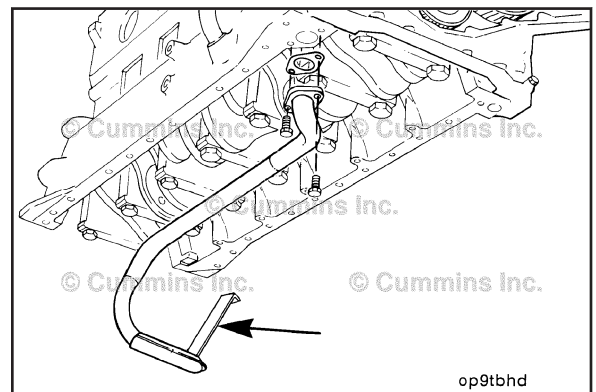

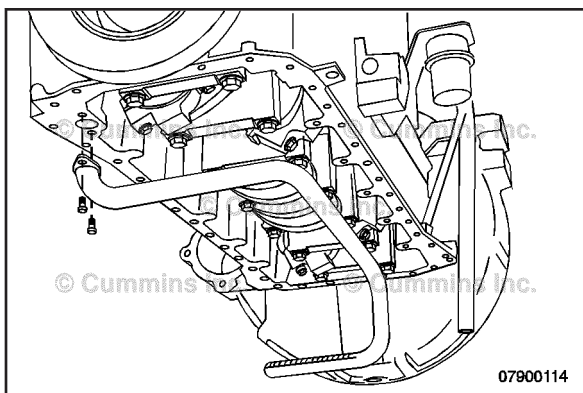

Lubricating Oil Pan (007-025)

Install

If the suction tube has been removed, install the suction tube. Refer to Procedure 007-035 in Section 7.

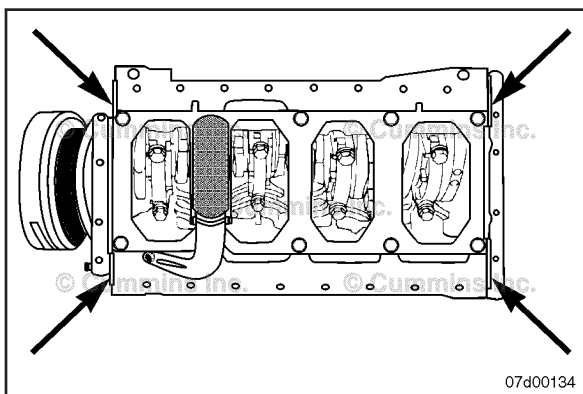

For rear gear train engines apply a 2-mm [1/16-inch] bead of sealant, Part Number 3164070, to the oil pan mounting surfaces at the cylinder block to front gear cover joints and the cylinder block to rear gear housing joints.

For front gear train engines, apply a 2-mm [1/16-inch] bead of sealant, Part Number 3164070, to the oil pan mounting surfaces at the cylinder block to front gear housing joint and the cylinder block to rear seal housing joint.

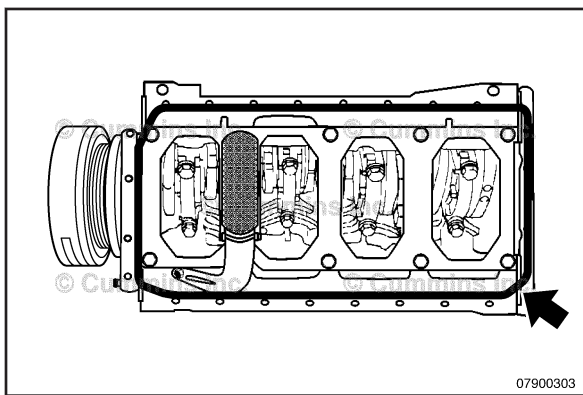

Oil Pan, Formed-in-Place Gasket

If installing a formed-in-place gasket pan, apply a 4-mm [1/8-inch] bead of sealant, Part Number 3164070, to the oil pan mounting surfaces at the cylinder block to front gear housing joints and the cylinder block to rear gear housing joints.

Make sure there is a continuous sealing path.

NOTE: Install three guide pins, Part Number 3164977, to improve alignment of the oil pan sealing components to the cylinder block.

NOTE: Install the oil pan housing within 10 minutes of applying the sealant, or it will **not** seal correctly. Once installed, allow the sealant to dry for 30 minutes before running the engine.

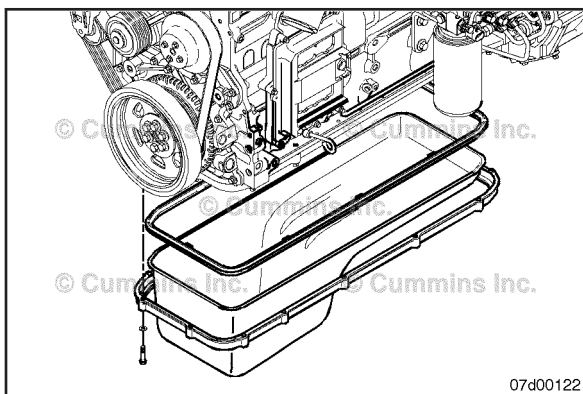

Oil Pan, Suspended

Assemble the gasket onto the oil pan.

Install the support mounting flange to the oil pan and gasket assembly.

Oil Pan, Suspended (four-cylinder)

Tighten all capscrews in the sequence shown in the illustration.

Torque Value: 26 N•m [230 in-lb]

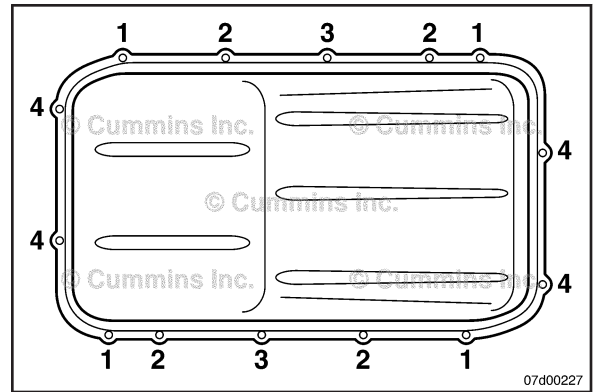

Oil Pan, Suspended (six-cylinder)

Tighten all capscrews in the sequence shown in the illustration.

Torque Value: 26 N•m [230 in-lb]

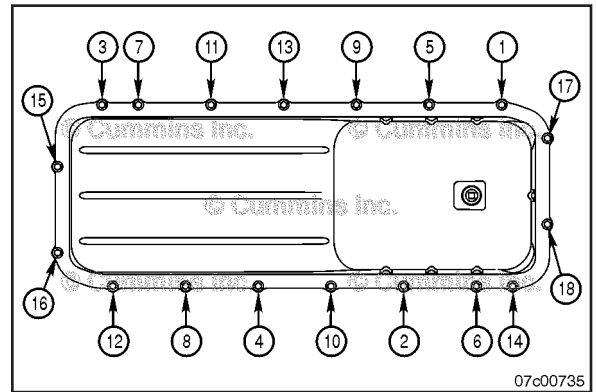

Oil Pan, Standard

Assemble a new gasket onto the oil pan.

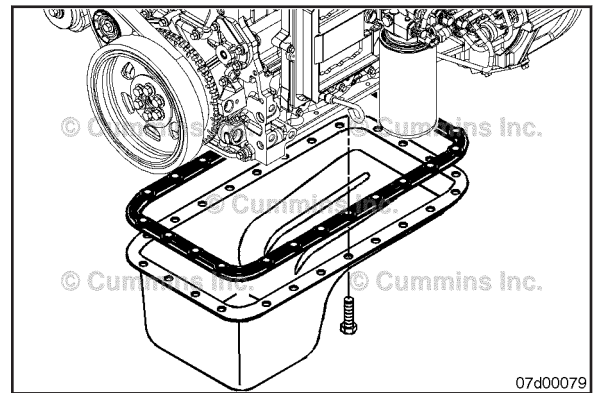

Four-Cylinder

Tighten all capscrews in the sequence shown in the illustration.

Torque Value: 28 N•m [249 in-lb]

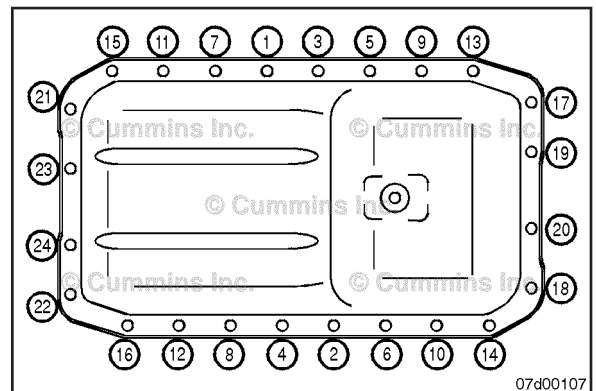

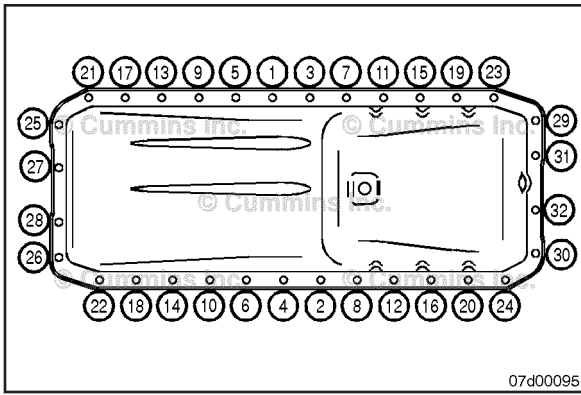

Six-Cylinder

Tighten all capscrews in the sequence shown in the illustration.



Torque Value: 28 N•m [249 in-lb]

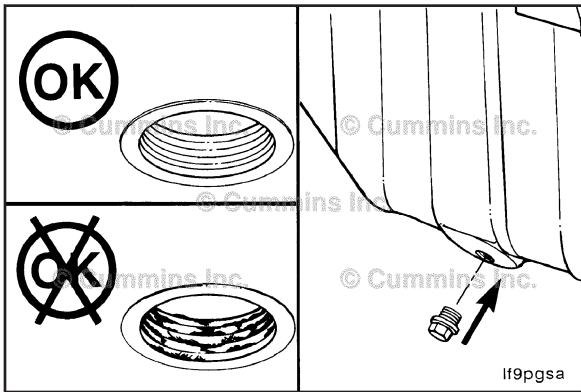

Clean and check the oil drain plug threads and sealing surface.

Install and tighten the oil pan drain plug.



Torque Value: 60 N•m [44 ft-lb]

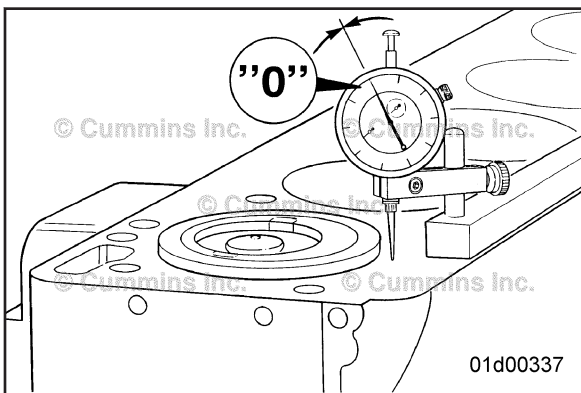

Cylinder Head Gasket (002-021) Measure

For engines requiring cylinder head gasket grading, measure piston protrusion.

NOTE: This procedure is only required after a piston, crankshaft, connecting rod, or block replacement. Otherwise, use the same grade gasket that was previously installed.

4.5L, 6.7L, and QSB5.9L Marine engines do **not** use graded gaskets.

Install depth gauge assembly, Part Number 3164438, on the block combustion deck and zero the gauge.

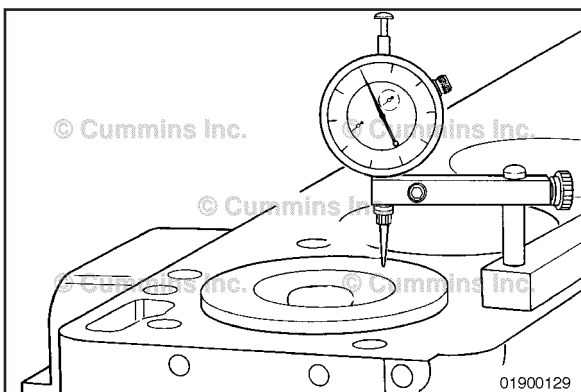

Use a barring tool, Part Number 3824591, to rotate the crankshaft to top dead center.

Move the dial indicator directly over the piston pin to eliminate any side-to-side movement.

Rotate the crankshaft **clockwise** and **counterclockwise** to find the highest dial indicator reading.

Record the reading.

Repeat on the remaining cylinders.

Calculate the average height by adding all numbers recorded and dividing by the number of cylinders.

Record the number calculated. This number will be used to determine which grade of cylinder head gasket to use.

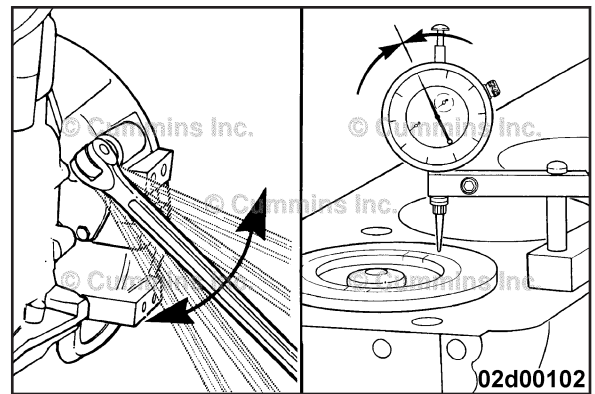

Each graded cylinder head gasket has a grade identification tab that indicates the thickness of the cylinder head gasket, thick or thin.

The location of the tab will vary according to the type of engine.

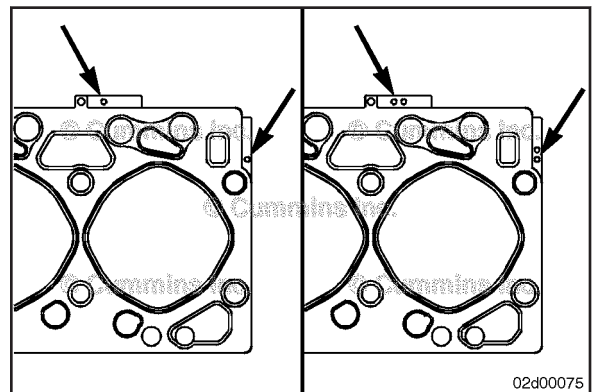

⚠ CAUTION ⚠

The cylinder head gaskets for 5.9 L engines without EGR and 5.9 L engines with EGR with oversize pistons or repair sleeve may visually appear similar, but the cylinder head gaskets can not be interchanged. Engine damage will result.

3.9L and 5.9L engines without EGR will have the grade identification tab on the exhaust side of the cylinder head gasket between cylinders 3 and 4 for 4 cylinder engines and between cylinders 5 and 6 for 6 cylinder engines.

5.9L engines with EGR, that have had oversize pistons or repair sleeves installed, will also have the identification tab on the exhaust side between cylinders 5 and 6.

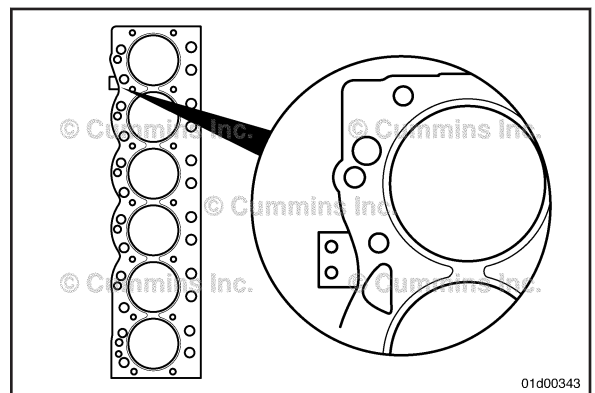

The thickness of the cylinder head gasket can be determined by the location of the holes in the cylinder head gasket grade identification tab. For thin cylinder head gaskets (A), the holes are spaced close together. For thick cylinder head gaskets (B), the holes are more widely spaced.

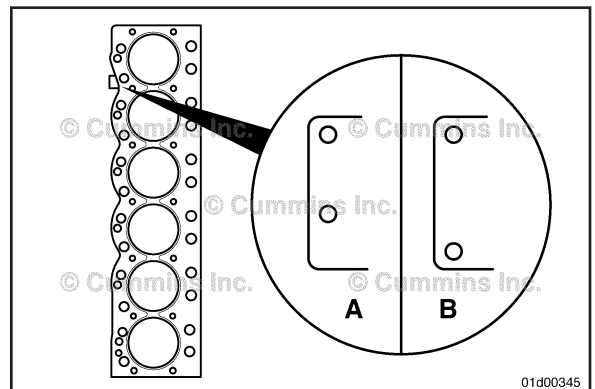

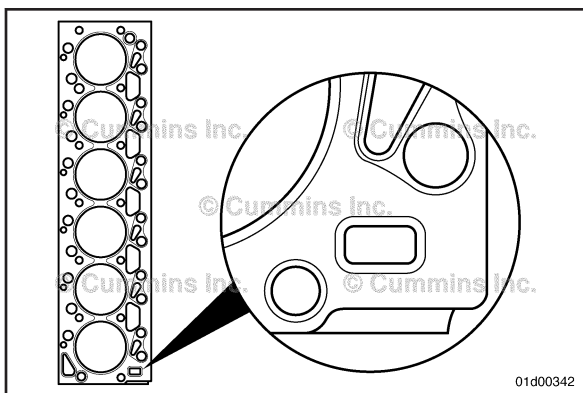

5.9 L engines with EGR have the grade identification tab located on the portion of the cylinder head gasket corresponding to the front of the engine on the intake side.

If a repair sleeve or oversize pistons have been installed, the grade identification tab will be on the exhaust side, as explained previously.

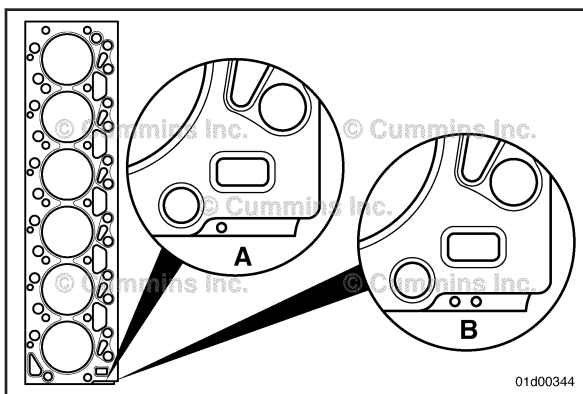

The thickness of the cylinder head gasket can be determined by the number of holes in the cylinder head gasket grade identification tab. There is 1 hole for thin cylinder head gaskets (A). There are 2 holes for thick cylinder head gaskets (B).

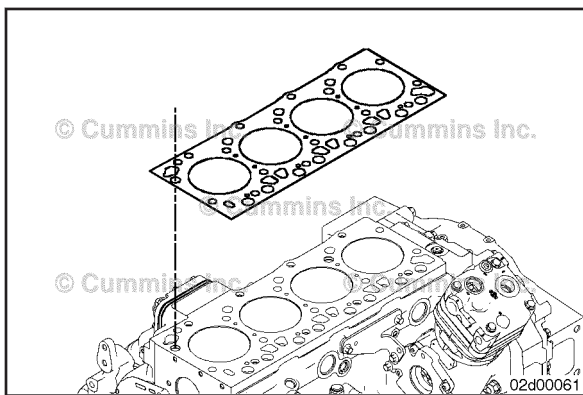

Using the average piston protrusion recorded earlier, determine which cylinder head gasket is needed from the following table:

Head Gasket Determination	
Average Piston Protrusion	Head Gasket Grade
≥ 0.30 mm [0.012 in]	Thick (B)
< 0.30 mm [0.012 in]	Thin (A)

Install

⚠CAUTION⚠

For 5.9 L engines with EGR, when using oversize pistons or repair sleeves a service specific cylinder head gasket must be used to make sure proper sealing of the combustion seal ring is acquired. Failure to use the correct cylinder head gasket can result in engine damage.

Only 5.9L engines with EGR have a service cylinder head gasket available when oversize pistons or repair sleeves are installed. The production cylinder head gasket combustion ring is **not** completely circular. The service gasket has an increased diameter combustion seal. This gasket **must** be used to make sure proper sealing of the combustion seal ring is acquired.

QSB 5.9 Marine 425 engines have a special cylinder head gasket that accommodates this engine's cylinder pressure requirements.

This gasket can be identified by:

- Witness marks at the front edge and front side of the gasket.
- Cummins Inc.'s "C's" printed on the gasket surface in dark blue ink.

QSB5.9 Marine gaskets do **not** have graded gaskets or service gaskets for oversize bores.

A new gasket **must** be installed. Do **not** reuse an old gasket.

Install the cylinder head gasket.

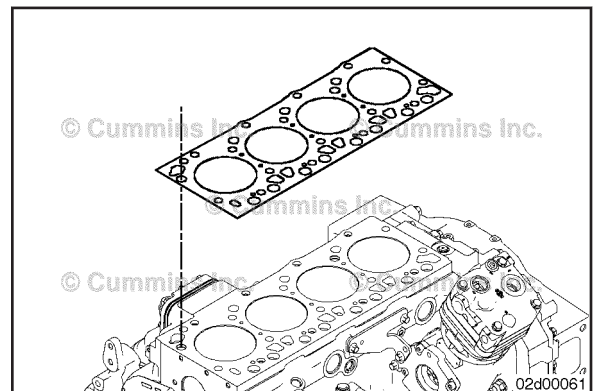
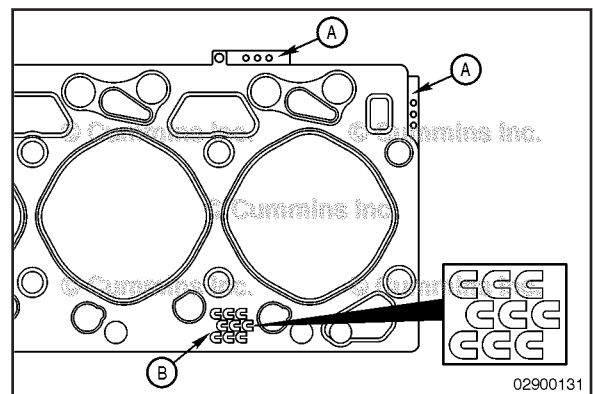
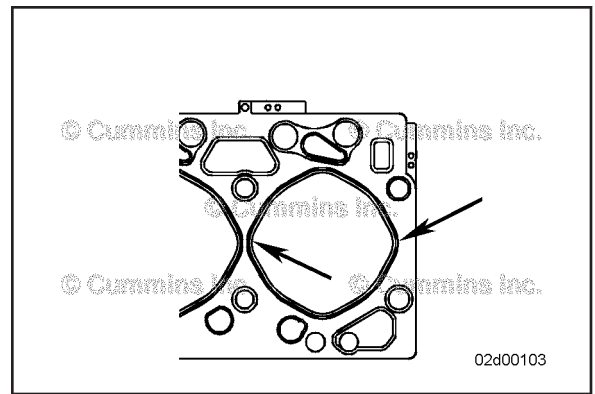

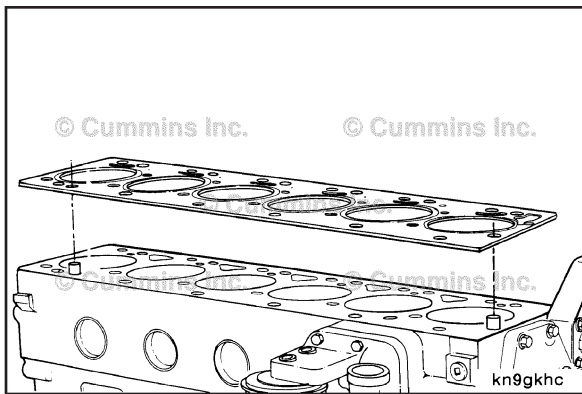

Cylinder Head (002-004)

Install



⚠ CAUTION ⚠

Make sure the gasket is correctly aligned with the holes in the cylinder block. Damage to the cylinder block can occur if the gasket is not aligned correctly.



NOTE: If a piston, crankshaft, connecting rod, or block replacement has been performed, the cylinder head gasket may require that it be graded. Refer to Procedure 002-021 in Section 2.

NOTE: Marine applications do **not** use cylinder head gasket grades. Refer to Procedure 002-021 in Section 2.

Install the cylinder head gasket. Refer to Procedure 002-021 in Section 2.

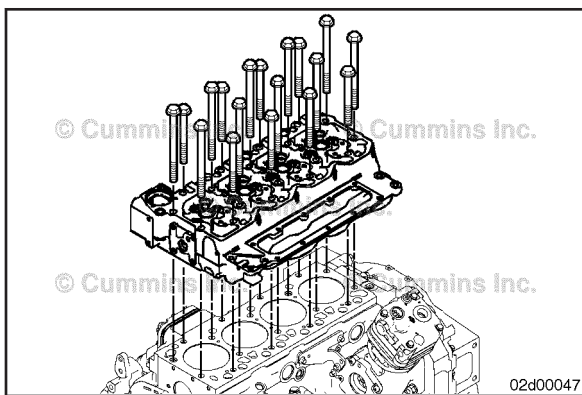

⚠ WARNING ⚠

This component weighs 23 kg [50 lb] or more. To reduce the possibility of personal injury, use a hoist or get assistance to lift this component.



Carefully put the cylinder head on the cylinder block and seat it onto the dowels.

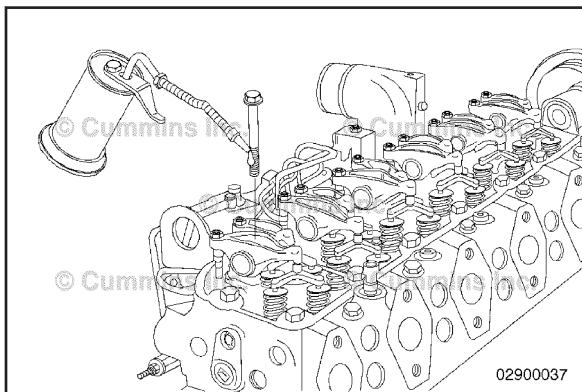

NOTE: If equipped with different length capscrews, the short bolts, 130 mm, are located in the outboard set of holes closest to the intake and exhaust ports. There are eight on the four-cylinder and twelve on the six-cylinder engines.



Lubricate the threads and under the heads on the cylinder head mounting capscrews with clean engine oil.

Install the capscrews and tighten finger-tight.

3.9L Engines

NOTE: If equipped with different length capscrews, the short bolts, 130 mm, are located in the outboard set of holes closest to the intake and exhaust ports. There are eight on the four-cylinder and twelve on the six-cylinder engines.

Use the illustrated sequence to tighten the cylinder head capscrews.

Tighten the capscrews.

3.9L Engine - Cylinder Head Torque Values			
Step	Capscrews	N•m	ft-lb
1	All capscrews	35	26
2	Inboard long capscrews only	55	41
3	All capscrews	Rotate 90-degrees clockwise	
4	All capscrews	Rotate 90-degrees clockwise	

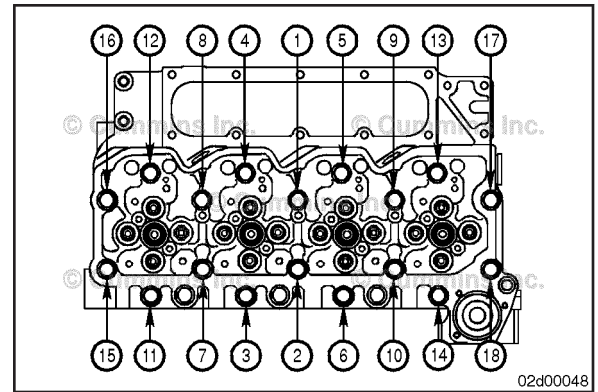

4.5L Engines

Use the illustrated sequence to tighten the cylinder head capscrews.

Tighten the capscrews.

4.5L Engine - Cylinder Head Torque Values			
Step	Capscrews	N•m	ft-lb
1	All capscrews	90	66
2	All capscrews	90	66
3	All capscrews	Rotate 90-degrees clockwise	

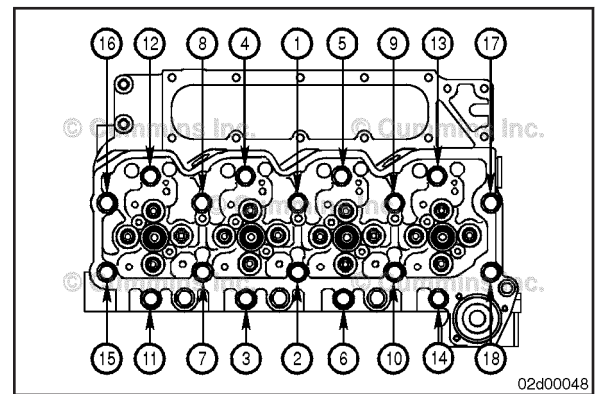

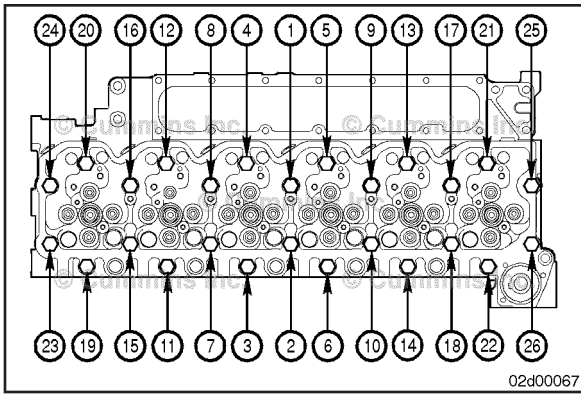

5.9 L Engines with Unequal Length Cylinder Head Capscrews

NOTE: If equipped with different length capscrews, the short bolts, 130 mm, are located in the outboard set of holes closest to the intake and exhaust ports. There are eight on the four-cylinder and twelve on the six-cylinder engines.

Use the illustrated sequence to tighten the cylinder head capscrews.

Tighten the capscrews.

5.9L Engines with Unequal Length Cylinder Head Capscrews - Cylinder Head Torque Values			
Step	Capscrews	N•m	ft-lb
1	All capscrews	35	26
2	Inboard long capscrews only	55	41
3	All capscrews	Rotate 90-degrees clockwise	
4	All capscrews	Rotate 90-degrees clockwise	

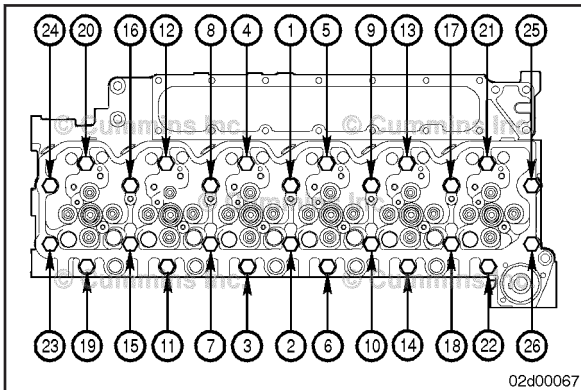

5.9 L and 6.7 L Engines with Equal Length Cylinder Head Capscrews

Use the illustrated sequence to tighten the cylinder head capscrews.

Tighten the cylinder head capscrews.

5.9L and 6.7L Engines with Equal Length Cylinder Head Capscrews - Cylinder Head Torque Values			
Step	Capscrews	N•m	ft-lb
1	All capscrews	90	66
2	All capscrews	90	66
3	All capscrews	Rotate 90-degrees clockwise	

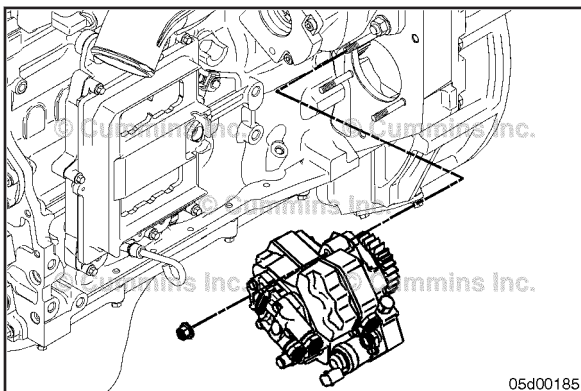

Fuel Pump (005-016)

Install

Automotive and Industrial

Install the fuel pump on the gear housing.

NOTE: Timing of the high-pressure pump with the crankshaft is **not** required.

Install the fuel pump mounting nuts and tighten.

Torque Value: 25 N•m [221 in-lb]

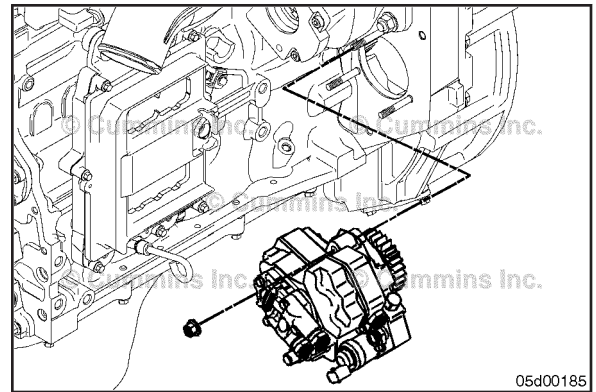

Install the high-pressure supply line from the high-pressure pump to the fuel rail and tighten the holding brackets.

NOTE: Apply a counter-torque on the high-pressure pump outlet port to prevent over-tightening.

Torque Value:

3.9L and 5.9L High-Pressure Supply Line
Step 1 30 N•m [22 ft-lb]

Torque Value:

4.5L and 6.7L High-Pressure Supply Line
Step 1 30 N•m [22 ft-lb]

Connect the EFC actuator valve wire harness connector.

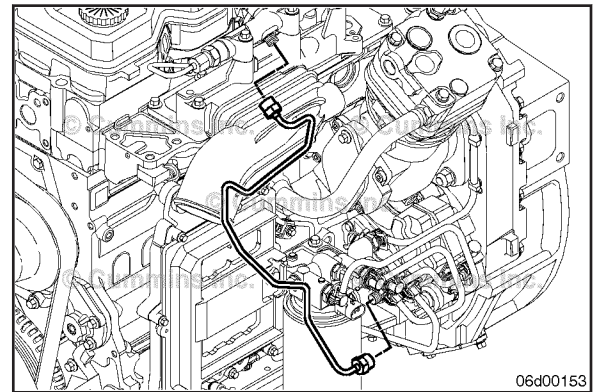

Front Gear Train

⚠ CAUTION ⚠

Place a clean cloth in the air-gap between the fuel pump drive gear and the gear cover, or use a screw driver to prevent the mounting nut and lock washer from being dropped into the front gear train.

⚠ CAUTION ⚠

The fuel pump drive gear is captive between the gear housing and the gear cover. Do not rotate the engine while the gear is not supported by the fuel pump drive shaft. The gear, gear housing, or gear cover can be damaged.

NOTE: The engine barring tool, Part Number 3824591, can be used to prevent the crankshaft from rotating while tightening the retaining nut.

Install the drive gear retaining nut and lock washer onto the drive shaft. Tighten the gear retaining nut.

Torque Value: 105 N•m [77 ft-lb]

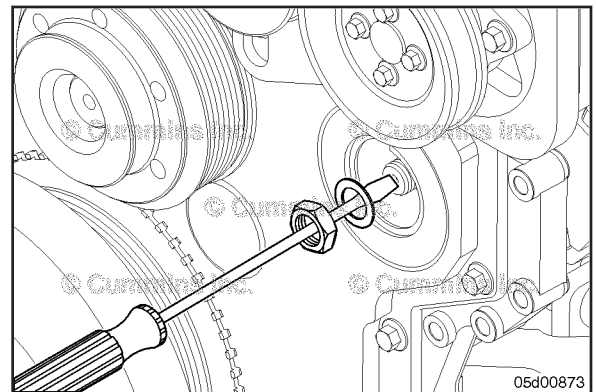

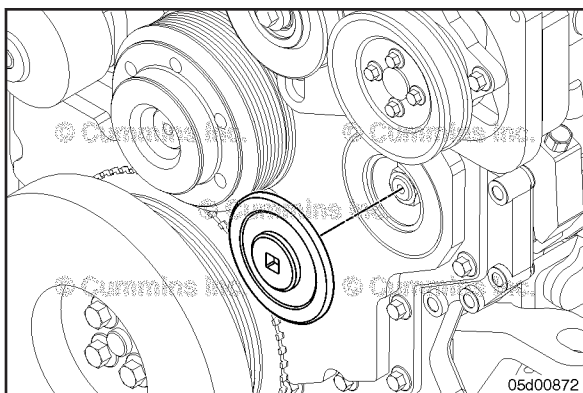

Install a new square cut o-ring onto the fuel pump drive access cover.



Install the fuel pump drive access cover with a 3/8-inch drive ratchet. The plate is threaded into the gear cover.

Torque Value: 8 N•m [71 in-lb]

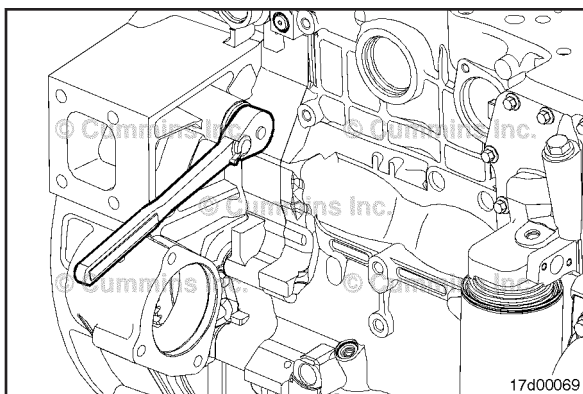

Air Compressor (012-014)

Time

NOTE: To make sure the air compressor does **not** contribute to engine vibrations when installed, the air compressor **must** be properly timed to the engine.

Use the barring tool, Part Number 3824591, or equivalent, to rotate the crankshaft until the number 1 is at top dead center (TDC).

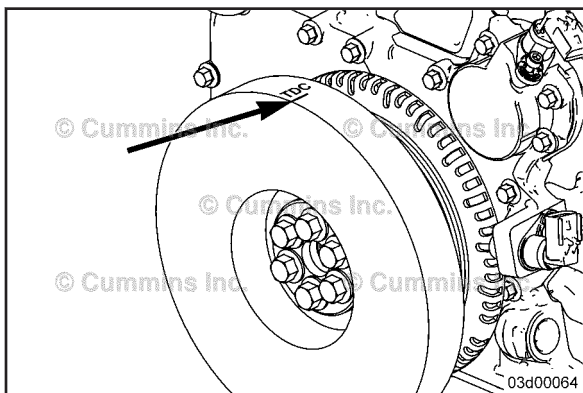

Align the vibration damper so that the TDC indicator on the vibration damper is at the 12-o'clock position.

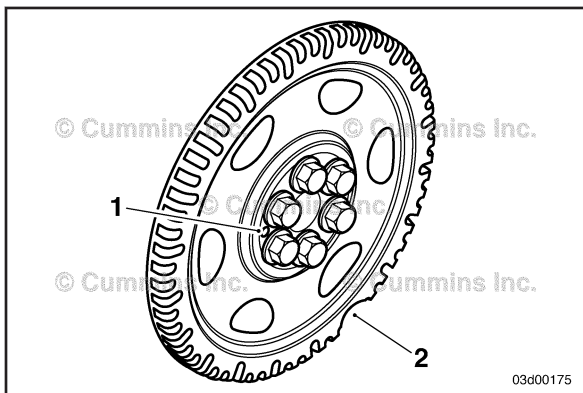

NOTE: If no TDC mark is present on either the vibration damper or the crankshaft speed indicator ring, align the large gap in the crankshaft speed indicator ring to the 5-o'clock position (2). The dowel pin can also be visible in the 9-o'clock position (1).

Wabco™ Air Compressors

Set the timing mark on the air compressor gear to the 9-o'clock position when looking at the gear. It **must** point at the casting depression on the side of the air compressor mounting flange.

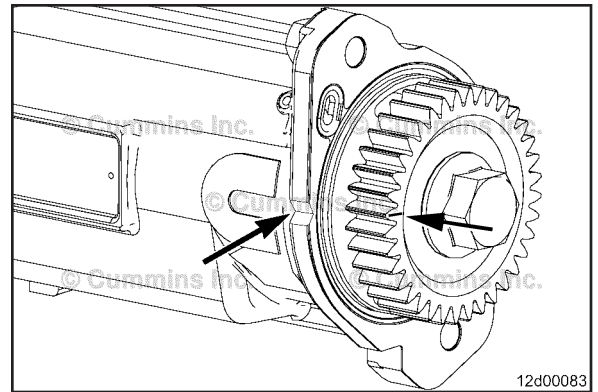

Knorr-Bremse™ Air Compressors

Set the air compressor to TDC by aligning the two timing marks on the rear of the compressor and on the rear drive.

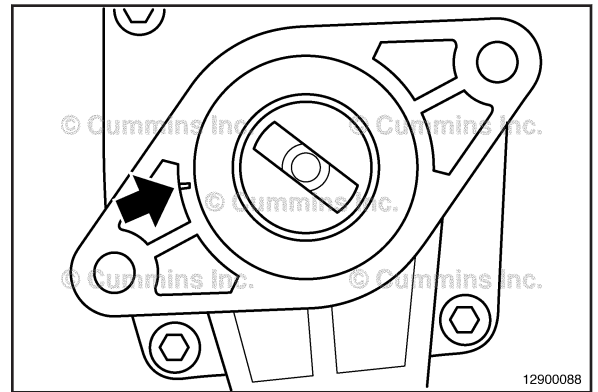

Install

Install the air compressor, gasket, mounting nut, and capscrew onto the front gear housing.



NOTE: If the stud is removed, use Loctite™ 3822040, or equivalent, and install the stud.

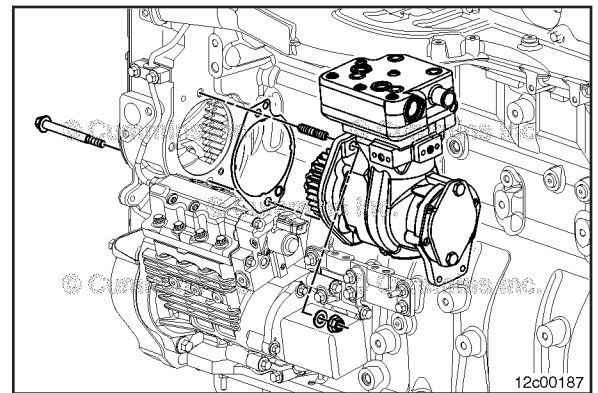

Tighten the capscrews.

Torque Value: 81 N•m [60 ft-lb]

Tighten the capscrews again.

Torque Value: 81 N•m [60 ft-lb]

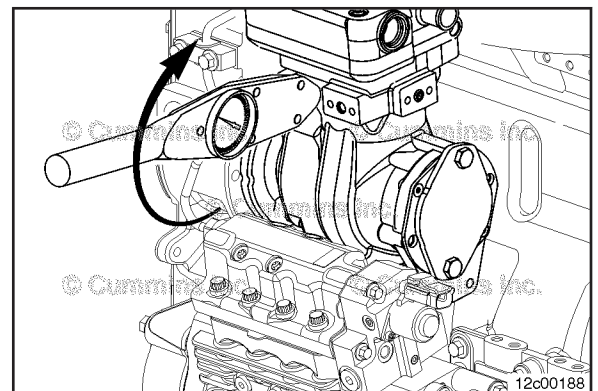

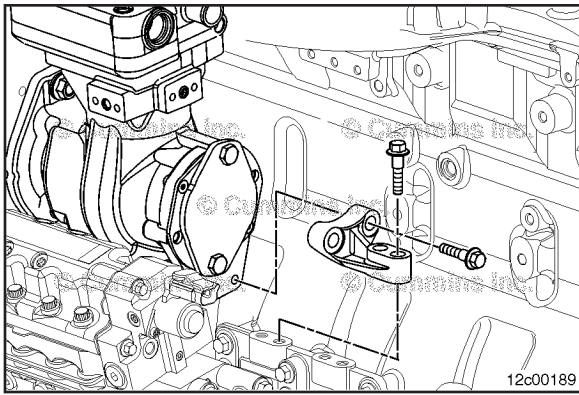

Install the air compressor mounting brace and four capscrews on the block beneath the air compressor. Start threading all four capscrews.

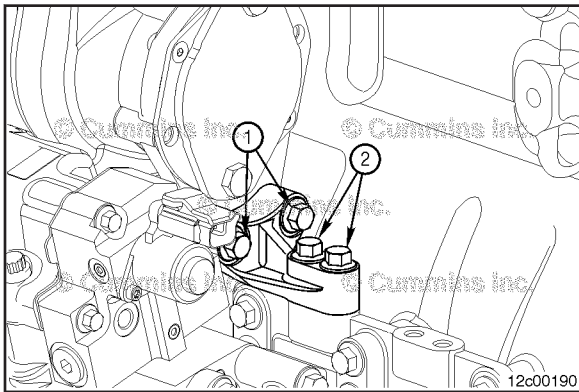

Tighten the capscrews in the sequence shown on the fuel pump support bracket and air compressor.

Torque Value: 61 N•m [45 ft-lb]

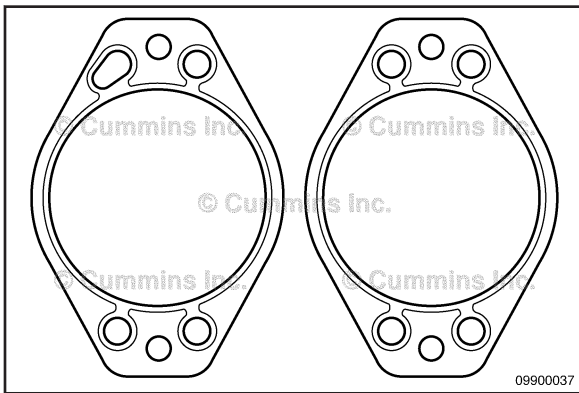

Accessory Drive (009-001)

Initial Check

NOTE: If oil supply to the accessory drive is **not** required and the gasket does **not** have oil passages, this check is **not** required. If the accessory drive uses o-rings for seals, this check is **not** required.

Prior to installing the accessory drive, identify which gasket is going to be installed so that, if necessary, the gasket can be properly oriented.

There are two types of accessory drive gasket:

- 1 Three round oil supply passages and one elongated oil supply passage
- 2 Four round oil supply passages.

It is preferred that, when installing the accessory drive, the gasket with the four round oil supply passages be used. The gasket can be installed in any orientation.

If only the gasket with the one elongated oil supply passage is available, install the gasket so that the elongated oil supply passage is **not** over the oil supply hole in the gear housing.

Install

⚠ CAUTION ⚠

Failure to line up the oil supply hole to the accessory drive properly will result in accessory drive damage.

Install the accessory drive and new gasket.

NOTE: If required, when installing the accessory drive and gasket, make sure the oil supply hole in the gear housing is lined up with the holes in the accessory drive and gasket. The accessory drive is marked for "Top" and "Bottom".

Install and tighten the two capscrews securing the accessory drive to the rear gear housing.

Torque Value: 62 N•m [46 ft-lb]

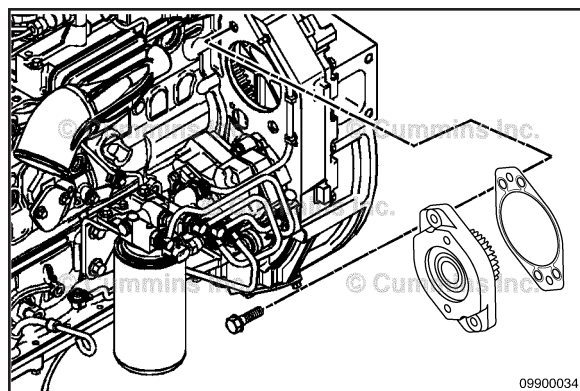

Fuel Lift Pump (005-045)

Install

NOTE: Make sure the inlet and outlet are properly oriented with the thin brass outlet section pointing toward the rear of the engine. Check the lift pump for labeling of inlet and outlet ports. Verify that the correct pump (12-VDC or 24-VDC) is installed.

Install the lift pump on the mounting bracket behind the ECM cooling plate.

Torque Value: 7 N•m [62 in-lb]

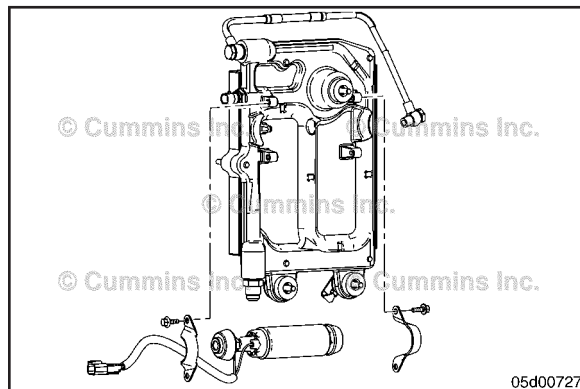

⚠ WARNING ⚠

Fuel is flammable. Keep all cigarettes, flames, pilot lights, arcing equipment, and switches out of the work area and areas sharing ventilation to reduce the possibility of severe personal injury or death when working on the fuel system.

Install the fuel lift pump inlet and outlet fuel lines.

Torque Value: 24 N•m [212 in-lb]

For 24-volt systems with voltage regulators, install the voltage regulator at the bottom edge of the ECM and install the lower two ECM mounting capscrews.

Torque Value: 25 N•m [221 in-lb]

Connect the fuel lift pump and, if equipped, the 24-volt voltage regulator connector(s) to the wiring harness.

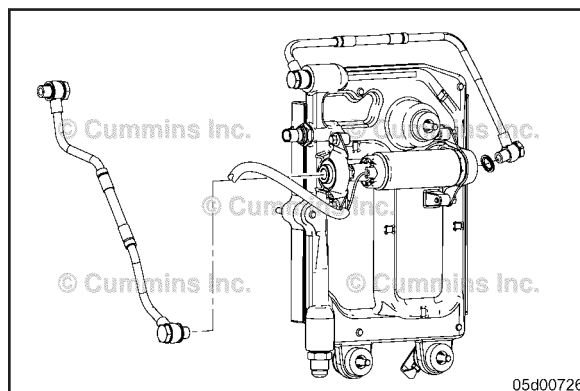

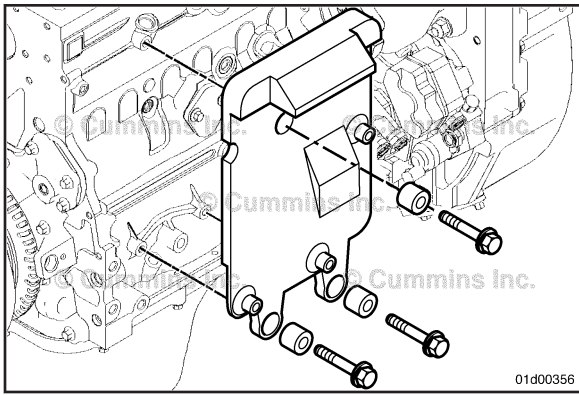

ECM Mounting Plate (001-103)

Install



NOTE: Be sure that the vibration isolators are installed in the ECM mounting plate prior to installing the capscrews.

Install the three mounting cap screws that secure the ECM mounting plate to the cylinder block.

Torque Value: 24 N•m [18 ft-lb]

NOTE: For engines with an aluminum ECM mounting plate, the ECM mounting plate and the steel yolk are installed as an assembly onto the cylinder block.

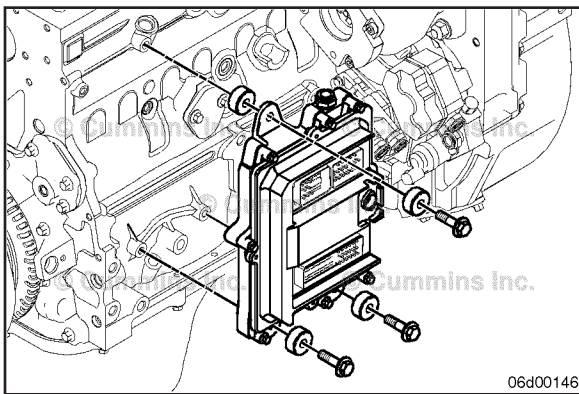

ECM Cooling Plate, Fuel Cooled (006-006)

Install



NOTE: For engines without an electric lift pump, the ECM and ECM cooling plate are installed as an assembly.

Install the ECM cooling plate on the engine.

Install heat-resistant grommets in proper locations.

Install the ECM cooling plate mounting capscrews.

Torque Value: 24 N•m [212 in-lb]

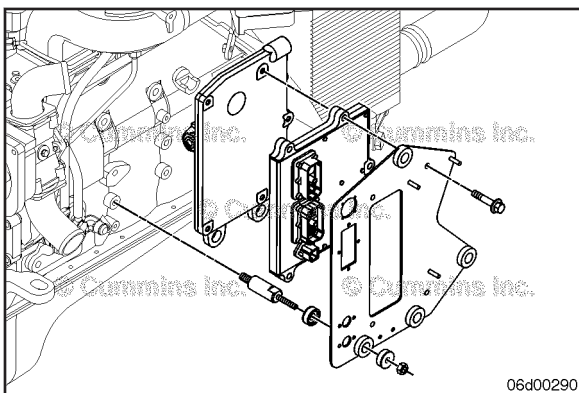

Align the mounting bracket over the three lower studs using new grommets. Loosely install the capscrew at the top of the bracket.



NOTE: Make sure all fuel lines and wiring harnesses are routed correctly and **not** pinched.

Install the three outer grommets and nuts.

Tighten the capscrew and nuts evenly.

Torque Value: 24 N•m [212 in-lb]

Air Intake Manifold (010-023)

Install

NOTE: Remove the tape from the intake manifold opening before continuing with the installation process.

Install the lower part of the intake manifold with a new gasket. Apply a light coating of thread sealant, Part Number 3824041, to the capscrews before installation. Only install the capscrews finger tight at this time.

Install the upper part of the intake manifold with a new gasket.

NOTE: There is a captive capscrew (1) in the manifold. Install the captive capscrew first, but only install it finger tight. Apply a light coating of thread sealant, Part Number, 3824041 to the capscrew before installation.

Install the rest of the capscrews in the upper part of the intake manifold. Apply a light coating of thread sealant, Part Number 3824041, to the capscrews before installation.

Tighten ALL of the intake manifold capscrews to the proper torque value.

Torque Value:

Air Intake Manifold Cover
Step 1 24 N•m [18 ft-lb]

Service Tip: If the captive capscrew is lost or broken, the threads in the captive capscrew hole (2) of the upper part of the intake manifold may be drilled or filed out to 9.5 mm (3/8 in.) diameter. This allows a standard M8 x 1.25 x 30 mm capscrew to be used in place of the captive capscrew. Apply a light coating of thread sealant part number 3824041 to the capscrew before installation and use caution to prevent dropping it into the intake manifold.

NOTE: Remove the tape from the intake manifold opening before continuing with the installation process.

If the engine was equipped with an integral cold starting aid, install the cold starting aid. Refer to Procedure Procedure 010-029

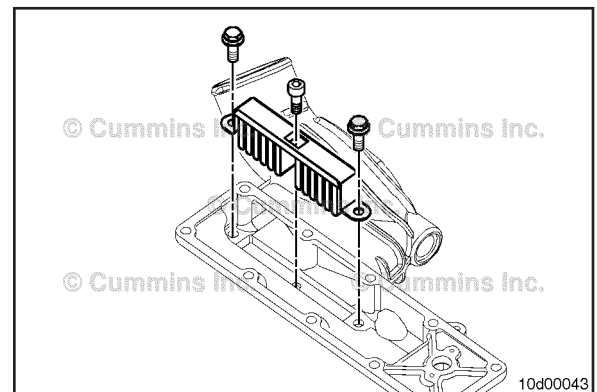
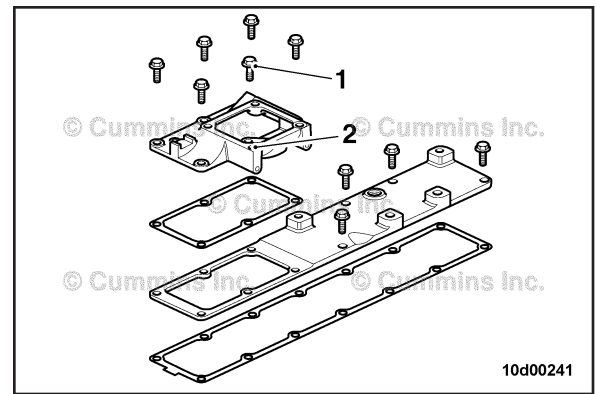

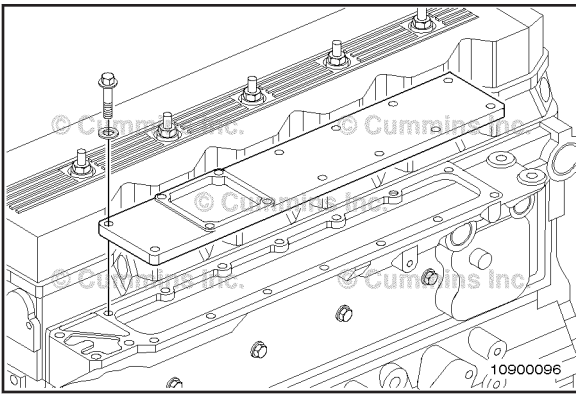

Install the air intake manifold and capscrews. Apply a light coating of thread sealant, Part Number 3824041, to the capscrews before installation.

If the air intake manifold was originally equipped with a gasket, replace the gasket. If the air intake manifold was originally equipped with sealant, re-seal the intake with RTV sealant, Part Number 3164070, or equivalent.

Torque Value:

Air Intake Manifold Cover
Step 1 24 N•m [18 ft-lb]

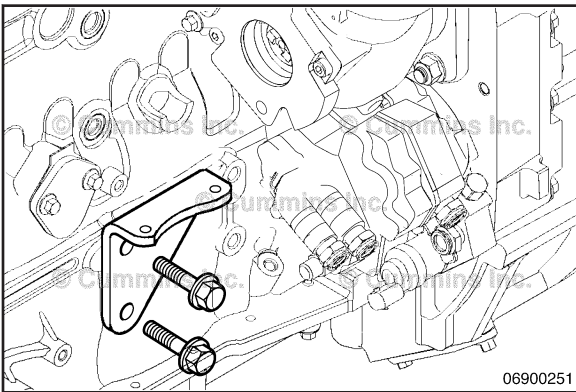

Fuel Filter Head (006-017)

Install



Low Mount Fuel Filter

Install the fuel filter head bracket.
Install the fuel filter head bracket capscrews.

Torque Value: 24 N•m [212 in-lb]

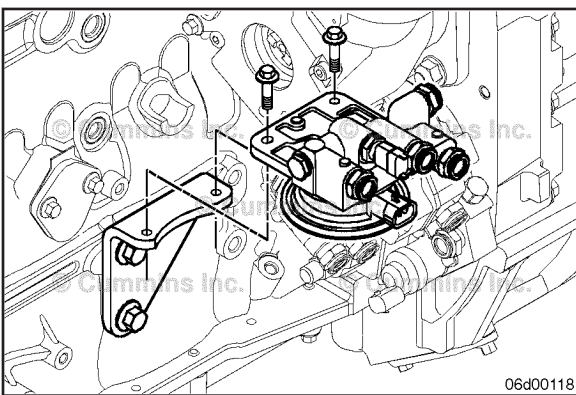

Install the fuel filter head.
Install the fuel filter head capscrews.



Torque Value: 24 N•m [212 in-lb]

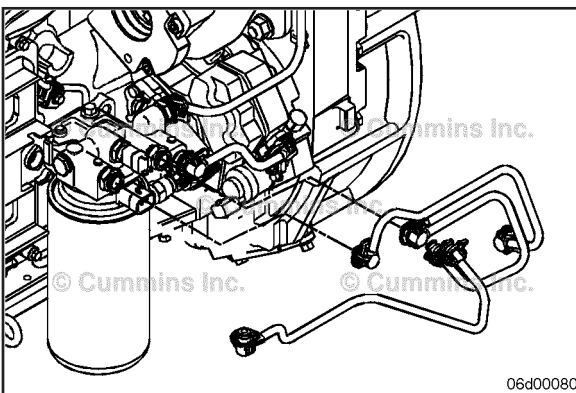

Install the fuel filter. Refer to Procedure 006-015.
Install fuel supply and drain lines. Refer to Procedure 006-024.



High Mount Fuel Filter

Install the fuel filter head bracket.

Install the fuel filter head bracket capscrews.

Torque Value: 24 N•m [212 in-lb]

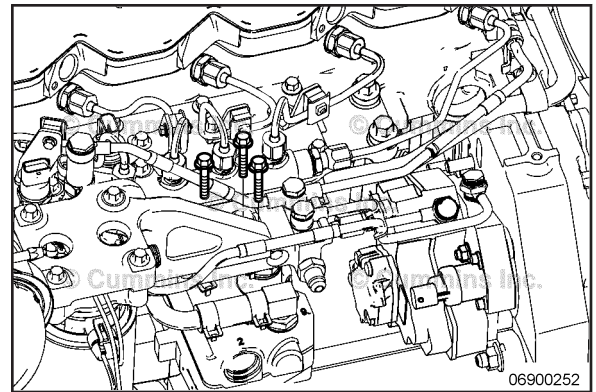

Install the fuel filter head.

Install the fuel filter head capscrews.

Torque Value: 24 N•m [212 in-lb]

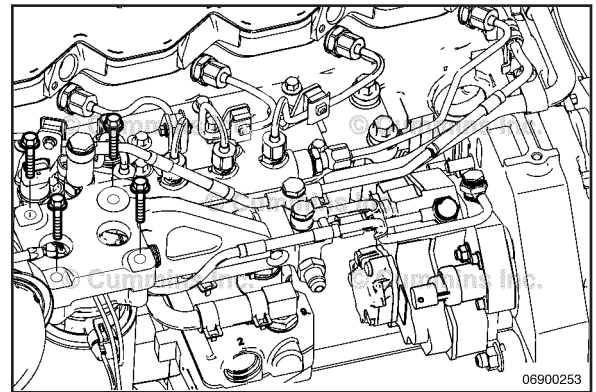

Install the fuel filter. Refer to Procedure 006-015.

Install fuel supply and drain lines. Refer to Procedure 006-024.

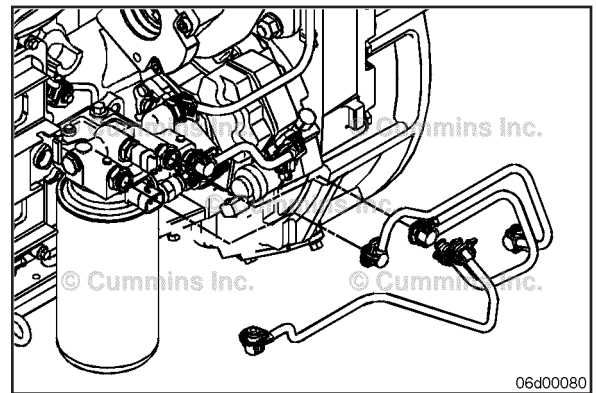

Marine Applications

NOTE: The filter head is marked with an IN and OUT for the line connections. Be sure the filter head is installed in the same direction as it was removed.

Install the fuel filter head.

Tighten the retaining capscrews.

Torque Value: 30 N•m [25 ft-lb]

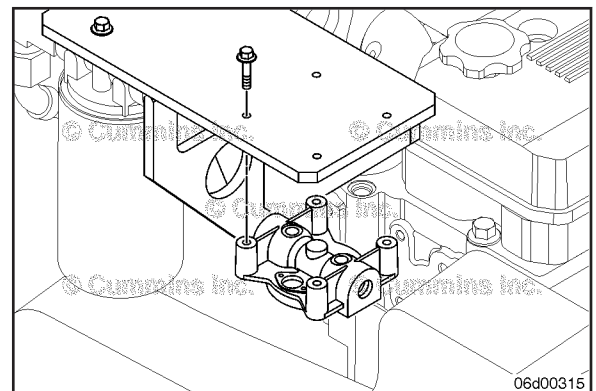



Fuel Filter (Spin-On Type) (006-015) Install

Lubricate the o-ring seal with clean lubricating oil.

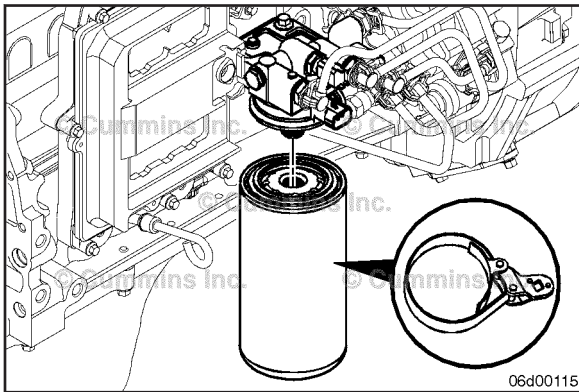

⚠ CAUTION ⚠

Mechanical overtightening can distort the threads as well as damage the filter element seal or filter can.



⚠ CAUTION ⚠

Do not pre-fill the pressure side fuel filter with fuel unless a clean side block off plug is used. The system must be primed after the fuel filter is installed. Pre-filling the pressure side fuel filter can result in debris entering the fuel system and damaging fuel system components.



NOTE: If available, pre-fill new filters, both pressure side and suction side, with clean fuel prior to assembly using the clean side block off plug packed with the filter. Do not pour fuel directly in the center of the filter, since this will allow unfiltered fuel to enter the system and can cause damage to fuel system components.

Use the following procedure for the correct fuel filter part number. Refer to Procedure 018-024 in Section V.

Install the filter on the filter head. Tighten the filter until the gasket contacts the filter head surface.

Tighten the fuel filter an additional $\frac{3}{4}$ turn after contact or follow filter manufacturer instructions.

Torque Value: 23 N•m [17 ft-lb]

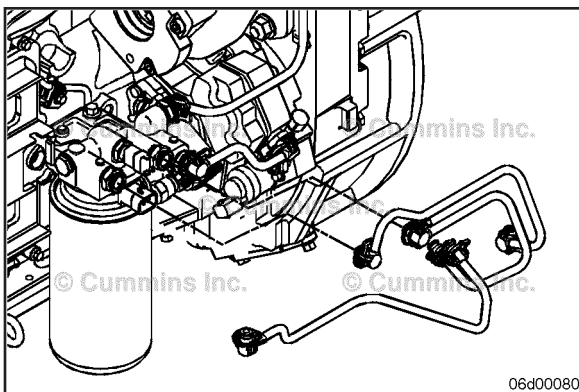

Fuel Supply Lines (006-024) Install

NOTE: Engines with a fuel cooled ECM cooling plate will have a fuel supply line connecting the ECM cooling plate to the inlet to the gear pump.

Install the fuel supply line connecting the ECM cooling plate to the inlet to the gear pump, if applicable.

Install the fuel supply line connecting the gear pump to the fuel filter head.

Install the fuel supply line connecting the fuel filter head to the inlet to the high pressure pump.

Install p-clips and p-clip mounting cap screws in locations noted during removal.

NOTE: For marine applications, a fuel supply line connects the fuel supply manifold to the inlet of the electric lift pump.



Install the fuel supply line connecting the fuel supply manifold to the inlet of the electric lift pump, if applicable.

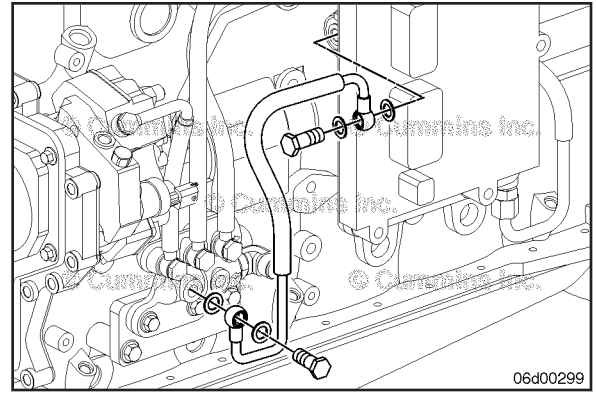

NOTE: For engines equipped with a fuel cooled ECM cooling plate, there is a fuel supply line connecting the ECM cooling plate to the electric fuel lift pump.



Install the fuel supply line connecting the ECM cooling plate to the electric fuel lift pump, if applicable.

Install the fuel supply line connecting the electric fuel lift pump to the inlet of the fuel filter head.

NOTE: For marine applications, a fuel supply line connects the fuel cooled ECM cooling plate to the inlet of the fuel filter head.

Install the fuel supply line connecting the fuel cooled ECM cooling plate to the inlet of the fuel filter head, if applicable. Install the fuel supply line connecting the fuel filter outlet to the gear pump inlet.

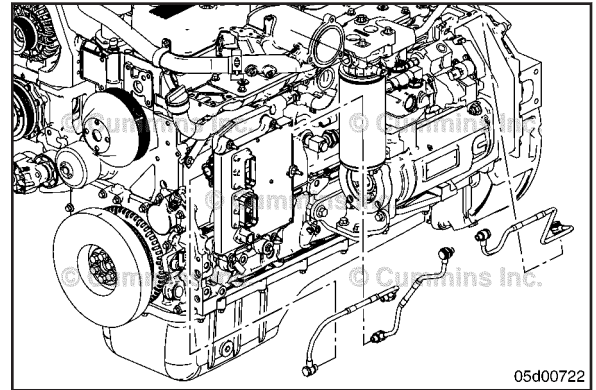

Install p-clips and p-clip mounting cap screws in locations noted during removal.

Connect the fuel line from the fuel filter to the high pressure fuel pump.



Torque Value:

Fuel Filter Connection
Step 1 37 N•m [27 ft-lb]



Torque Value:

Banjo Bolt Connection
Step 1 24 N•m [221 in-lb]

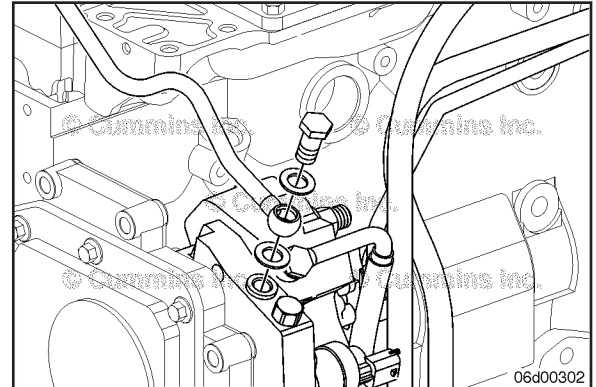

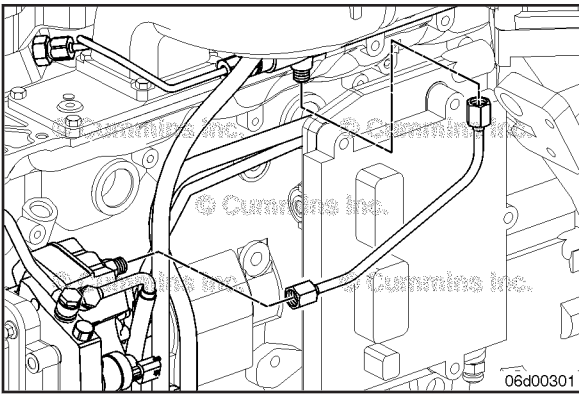

Connect the fuel line from the high pressure fuel pump to the fuel rail.

Torque Value:

Fuel Rail Fitting
Step 1 37 N•m [27 ft-lb]



Torque Value:

Fuel Pump Banjo Bolt
Step 1 24 N•m [221 in-lb]

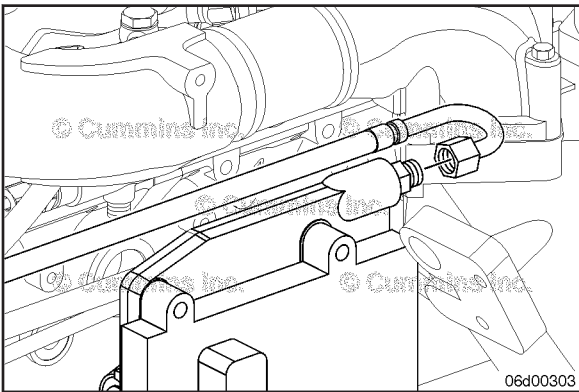

Connect the fuel line from the ECM cooling plate to the fuel filter.

Install the p-clip(s) in their original location(s)

Torque Value:

Fuel Line Straight Thread Connections
Step 1 37 N•m [27 ft-lb]



Torque Value:

P-Clips
Step 1 24 N•m [221 in-lb]

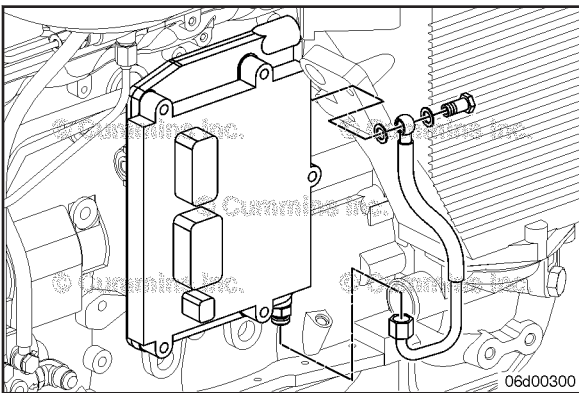

Connect the fuel line from the fuel lift pump to the ECM cooling plate.

Torque Value:

Straight Thread Connection
Step 1 37 N•m [27 ft-lb]



Torque Value:

Banjo Bolt Connection
Step 1 24 N•m [221 in-lb]

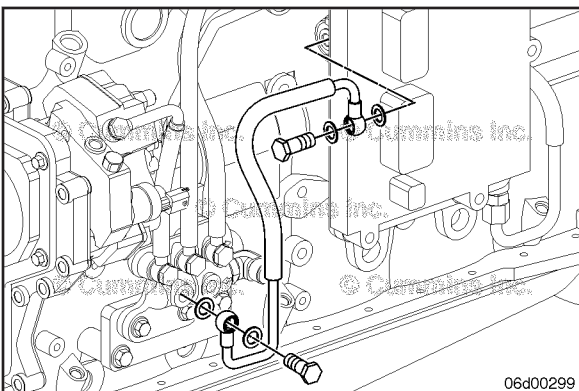

Connect the fuel line from the combined fuel manifold and the fuel lift pump.

Torque Value:

Banjo Bolt Connections
Step 1 24 N•m [221 in-lb]



Fuel Drain Lines (006-013)

Install

Install the fuel drain lines according to routing noted during removal.

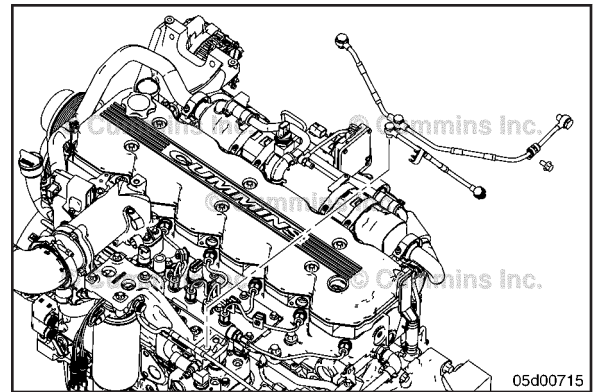

NOTE: The fitting for the injector return flow on the back of the cylinder head contains a check valve to maintain proper back-pressure. Fuel exiting the check valve returns to the tank.

Install the injector return flow fitting into the back of the cylinder head.

NOTE: For engines with quick-disconnect fittings; attach the fuel drain line to the injector return flow drain fitting. Securely lock the connector.

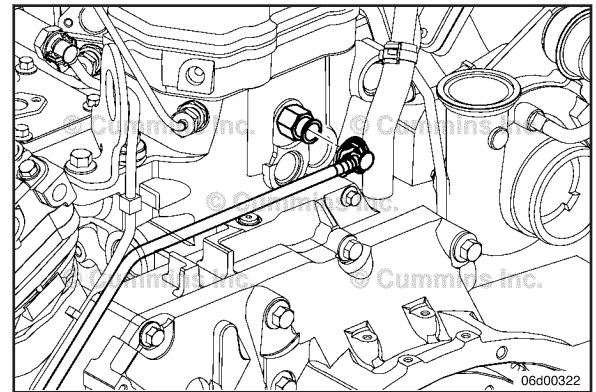

Install the fuel drain line(s) on the fuel return manifold.

NOTE: For marine applications each of the fuel drain lines individually connect to the fuel return manifold.

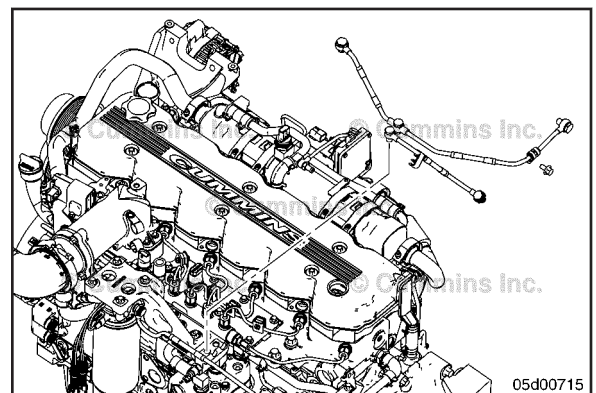

Install the fuel drain line on the fuel rail pressure relief valve.

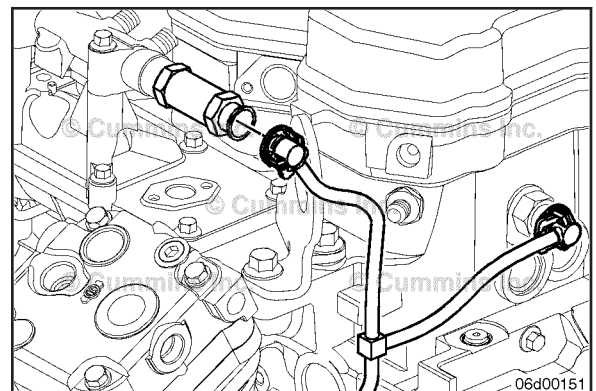

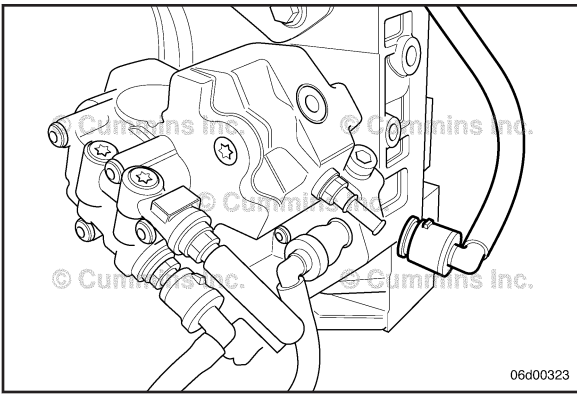

Install the fuel drain line on the fuel injector pump.

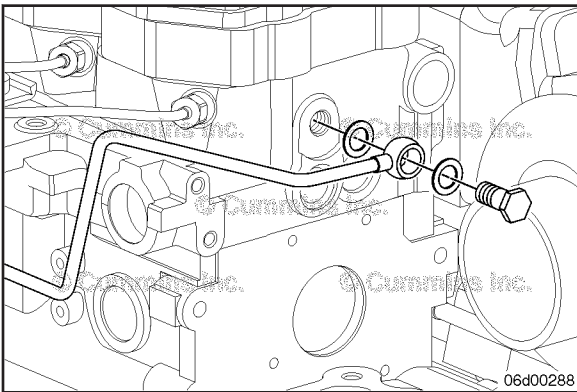

NOTE: The fitting for the injector return flow on the back of the cylinder head contains a check valve to maintain proper back pressure. Fuel exiting the check valve returns to the combined fuel manifold then to the fuel cooler and fuel tank.



Install the fitting using new sealing washers.

Torque Value: 24 N•m [212 in-lb]

Install the other end of the fuel line to the combined manifold using a banjo bolt and new sealing washers.

Torque Value: 24 N•m [212 in-lb]

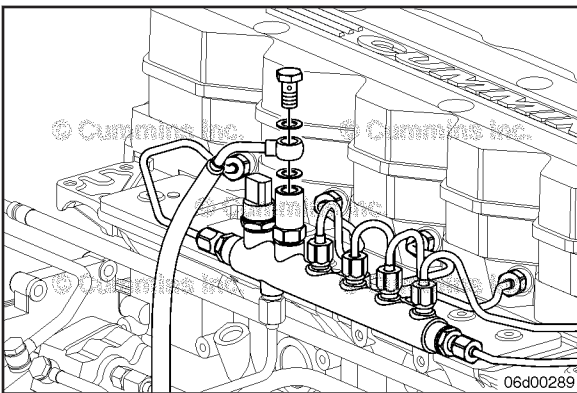

Install the fuel line from the fuel pressure relief valve to the combined fuel manifold using new sealing washers and banjo bolt.



Torque Value: 24 N•m [212 in-lb]

Install the fuel line from the high-pressure fuel pump to the combined fuel manifold using new sealing washers and two banjo bolts.

Torque Value: 24 N•m [212 in-lb]

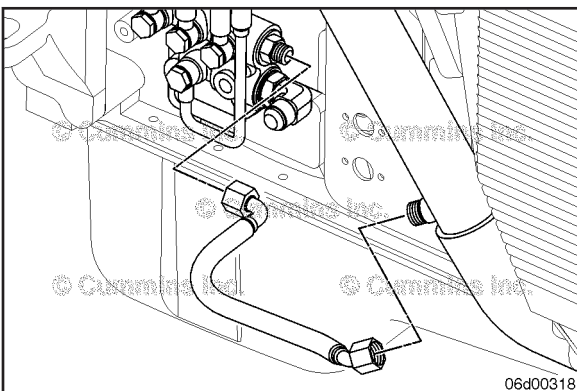

Install the fuel line from the combined fuel manifold to the fuel cooler. Use a second wrench at the fuel cooler to prevent damaging the cooler when tightening the fitting.



Torque Value: 24 N•m [212 in-lb]

Open the fuel supply and return valves.

Prime the fuel system. Refer to Procedure Procedure 005-016

Operate the engine and check for leaks.

Injector (006-026)

Remove

Disconnect the solenoid wires.

Remove the two injector hold-down capscrews and remove the injector hold-down clamp.

NOTE: The injector hold-down clamp is **not** removable on all engines.

Use the injector remover, Part Number 3823024, to remove the injector from the cylinder head.

NOTE: A small heel pry bar can also be used to pry up the injector. Pry up the injector hold-down flange (part of the injector body) just above the cylinder head casting).

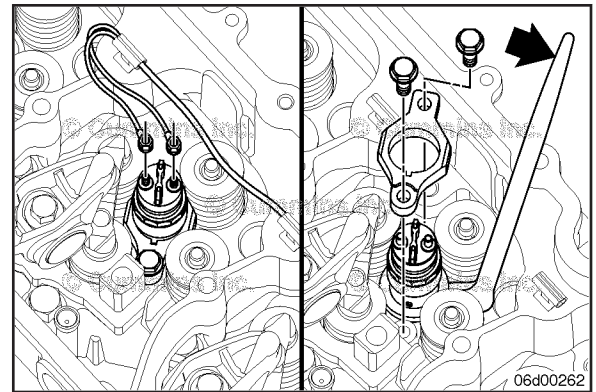

Install

Make sure the injector bore is clean and that **only** one (1) sealing washer is installed on the injector nozzle.

The rounded edge of the injector hold-down clamp is positioned toward the rocker levers. The fuel inlet hole on the injector faces the intake side of the engine.

NOTE: The injector hold-down is removable on some injectors.

Lubricate the injector o-ring with clean engine oil.

Align the injector in the cylinder head in the proper orientation (fuel inlet toward the high-pressure fuel connector).

Use the injector solenoid shipping cap. Make sure the injector is seated in the injector bore.

NOTE: If the injector solenoid shipping cap is **not** used to install the injector, be careful that pressure is **not** placed on the wire terminals. Wire terminals could break off if they are used to push on the injector.

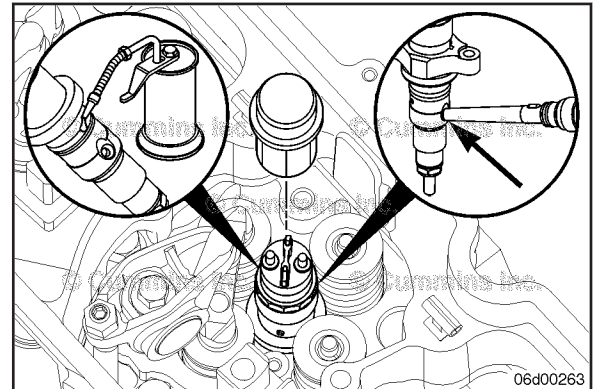

Install the injector hold-down and injector hold-down capscrews, but do **not** tighten.

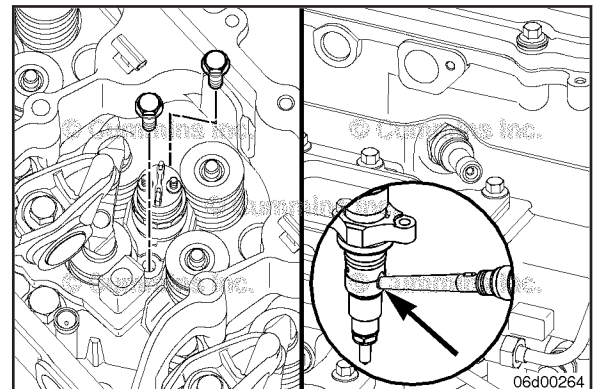

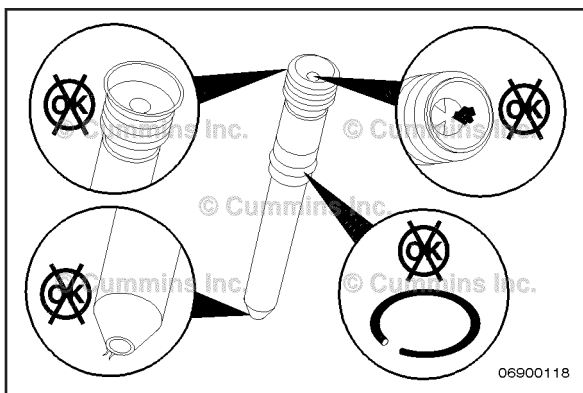

Inspect the fuel connector. Look for burrs or deformation around the inlet and outlet sides of the connector.

Check the edge filters for signs of plugging or material contamination.

Do **not** reuse a high-pressure fuel connector if debris is present.

Check for o-ring tearing or deterioration.

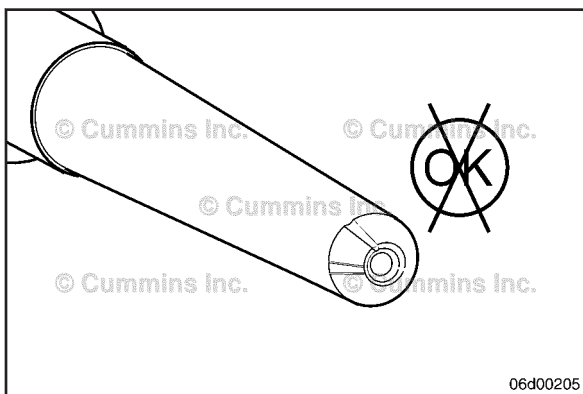

Inspect the outlet sealing surface of the high-pressure connector for wear, an uneven seating surface, or signs of leakage.

When a high-pressure fuel leak is present, small lines or cuts in the connector will be eroded into the seating surface.

The high-pressure connector and injector **must** be replaced when the condition is observed.

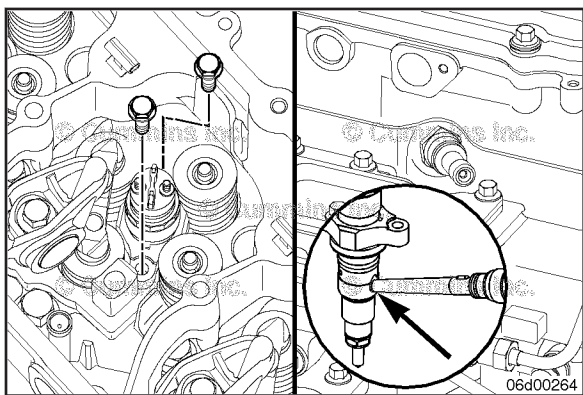

Install the high-pressure fuel connector making sure the end of the high-pressure fuel connector is in the injector inlet port.



Start the high-pressure fuel connector retaining nut and tighten partially.

Torque Value: 15 N•m [133 in-lb]

This is **not** the final torque for the high-pressure fuel connector retaining nut.

Tighten the injector hold-down capscrews.

Make sure to tighten the hold-down capscrews evenly. Check to make sure the gap between the hold-down clamp and the injector is equally spaced around the injector body.

Tighten finger-tight and alternate between capscrews, turning 90 degrees per turn until reaching the following torque value.

Torque Value:

(3.9L and 5.9L): 10 N•m [89 in-lb]

Tighten finger-tight and alternate between capscrews turning 90 degrees per turn until reaching the following torque value.

Torque Value:

(4.5L and 6.7L): 8 N•m [71 in-lb]

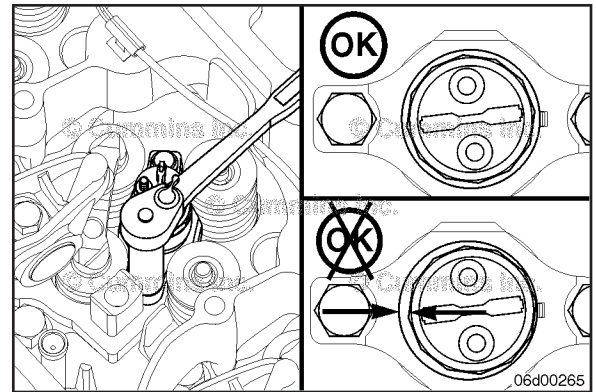

⚠ CAUTION ⚠

The injector solenoid terminals will yield and may malfunction if too much torque is applied. Do not over tighten.

Tighten the high-pressure fuel connector retaining nut. Refer to Procedure 006-052 in Section 6.

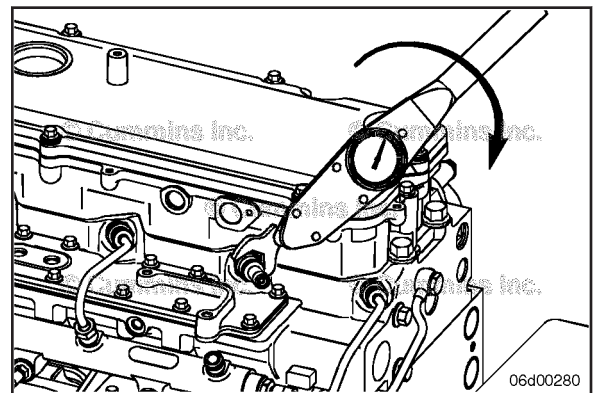

Connect and tighten the solenoid wires.

Torque Value: 1.5 N•m [13 in-lb]

Use service tool, Part Number 3823208, or a torque wrench.

Be sure the solenoid wires can **not** make contact with the rocker levers when installed.

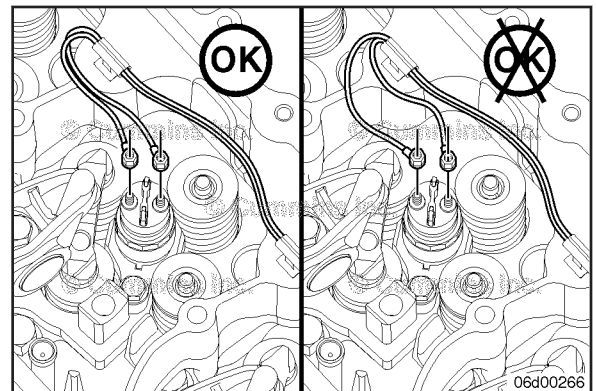

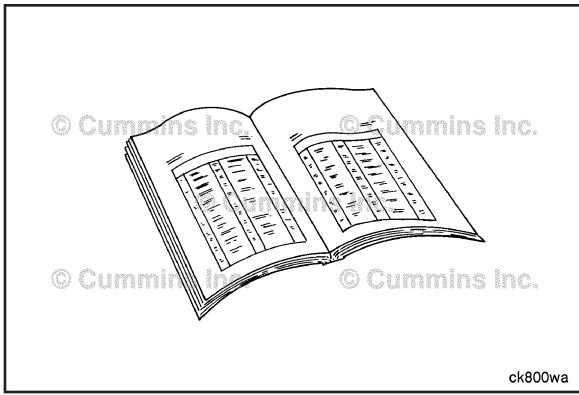

Finishing Steps



- Install the exhaust rocker and adjust the exhaust valve lash. Refer to Procedure 003-008 in Section 3.
- Install the rocker lever cover. Refer to Procedure 003-011 in Section 3.
- Install the high-pressure fuel line from the fuel rail to the high-pressure connector. Refer to Procedure 006-051 in Section 6.
- For Marine applications, **open** fuel supply and return valves.
- Operate the engine and check for leaks.

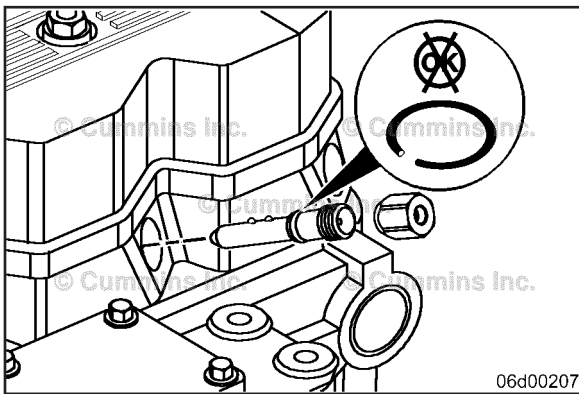

Fuel Connector (Head Mounted) (006-052)

Install



Lubricate the fuel connector o-ring and the threads on the fuel connector retaining nut.



Carefully insert the fuel connector, aligning the guide ball with the slot in the cylinder head at the 12-o'clock position.

NOTE: Use even axial force when installing to prevent the possibility of damage. Make sure **not** to tear the o-ring as the connector is being installed.

NOTE: If the injector was removed along with the high-pressure connector, the installation steps **must** be followed. Refer to Procedure 006-026 in Section 6.

Tighten the fuel connector retaining nut.

Torque Value:

Fuel Connector (cylinder head-mounted)
Step 1 55 N•m [41 ft-lb]

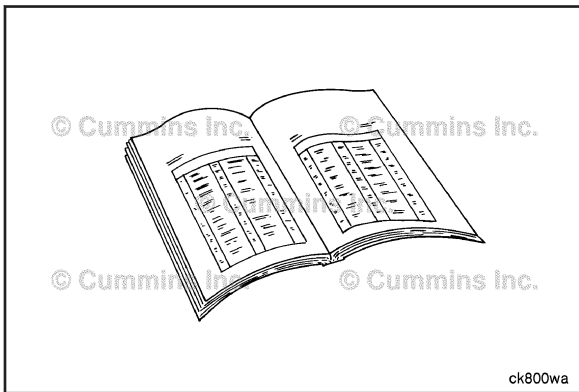

Finishing Steps

⚠ WARNING ⚠



Make sure the fuel inlet and return valves are returned to the open position before cranking engine. Engine damage can result if valves are in the wrong position when engine is cranked or started. Environmental damage can also occur. Refer to Procedure 006-999 in Section F.



- Install the high-pressure injector supply line. Refer to Procedure 006-051 in Section 6.
- For marine applications, **open** the fuel supply and return valves.
- Operate the engine and check for leaks.

Fuel Rail (006-060)

Install

Install the fuel rail on the engine.
Hand-tighten the fuel rail capscrews.

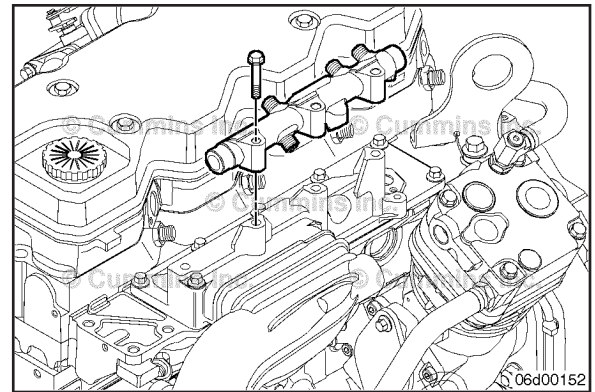

Hand-tighten the holding bracket capscrews to loosely fit the high-pressure pump to fuel rail line to the cylinder block.



Connect the high-pressure supply line to the high-pressure fuel pump and high-pressure fuel rail.



NOTE: Apply a counter-torque on the high-pressure pump outlet port to prevent overtightening.

Torque Value:

3.9L and 5.9L High-Pressure Supply Line
Step 1 30 N•m [22 ft-lb]

Torque Value:

4.5L and 6.7L High-Pressure Supply Line
Step 1 36 N•m [27 ft-lb]

Tighten the high-pressure fuel line holding bracket capscrews

Torque Value: 24 N•m [212 in-lb]

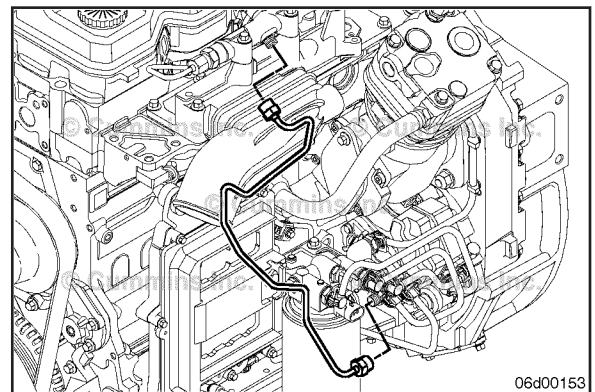

⚠CAUTION⚠

Injector supply lines and the high-pressure supply line must be torqued prior to tightening the fuel rail cap screws.

Install the injector supply line(s) that connect the fuel rail to the fuel injectors. Refer to Procedure 006-051 in Section 6.

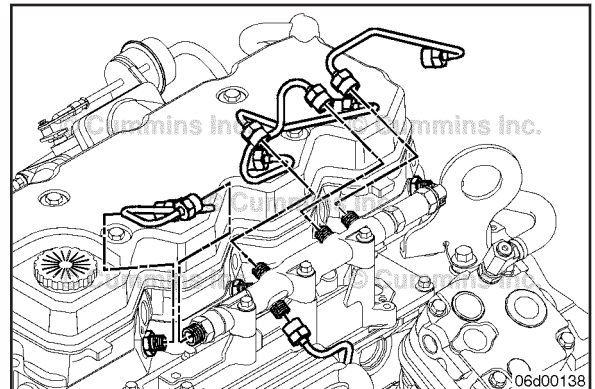

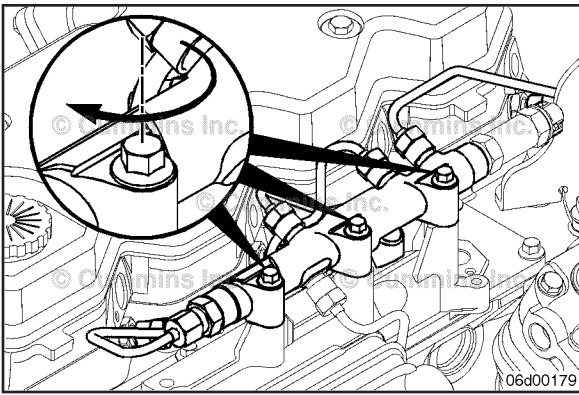

NOTE: If the fuel filter head bracket capscrows were loosened during removal of the fuel rail, tighten the fuel filter head bracket capscrows. Be sure that the fuel filter head bracket is **not** in contact with the high-pressure supply line connecting the high-pressure fuel pump to the fuel rail. Refer to Procedure 006-017 in Section 6, for the fuel filter head bracket.

Tighten the fuel rail capscrows.

Torque Value: 24 N•m [212 in-lb]

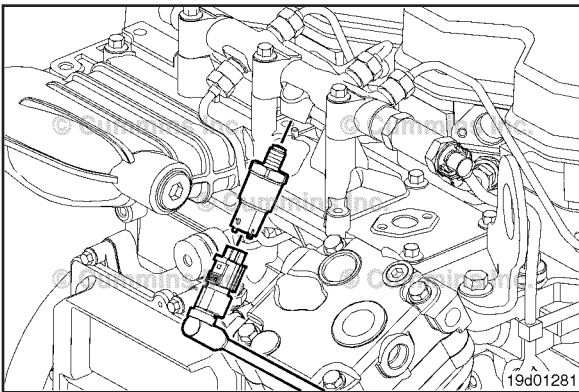

Install the fuel rail pressure sensor, if applicable.

Torque Value: 70 N•m [52 ft-lb]

Connect the fuel pressure sensor connector.

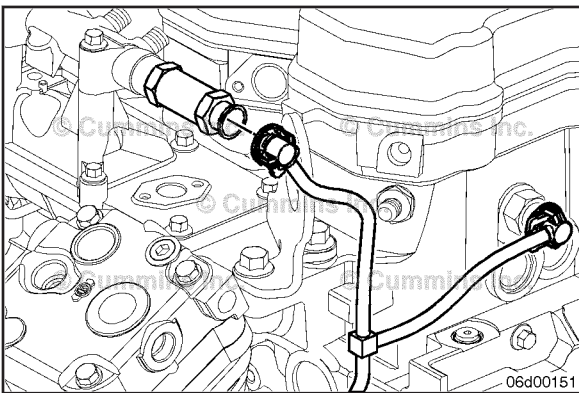

NOTE: The fuel rail pressure relief valve drain line has either a banjo fitting or a quick-disconnect fitting. Be sure that the quick disconnect is locked in place, if applicable.

NOTE: Overtightening the fuel pressure relief valve can result in a leak.

Install the fuel pressure relief valve and tighten, if applicable.

Torque Value: 100 N•m [74 ft-lb]

Connect the fuel rail pressure relief valve drain line. Refer to Procedure 006-013 in Section 6.

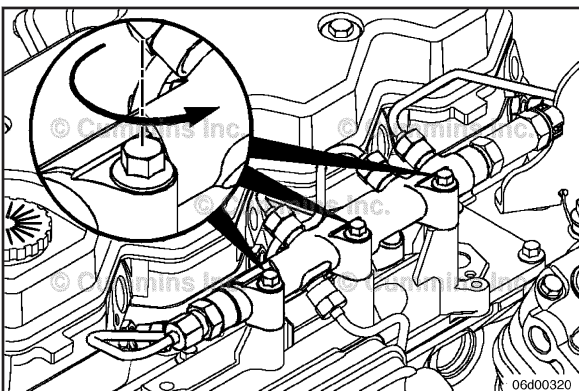

Injector Supply Lines (High Pressure) (006-051)

Install

Loosen the capscrows for the fuel rail. Do **not** remove the fuel rail. The capscrows are loosened to allow proper alignment of the fuel rail after installing the new fuel line.

Install and hand-tighten all of the fuel lines.
Tighten the Injector High Pressure Supply Lines:
3.9L and 5.9L **without** electric lift pump.
Torque Value: 22 N•m [195 in-lb]
5.9L **with** electric lift pump.
Torque Value: 30 N•m [22 ft-lb]
4.5L and 6.7L engines.
Torque Value: 35 N•m [26 ft-lb]

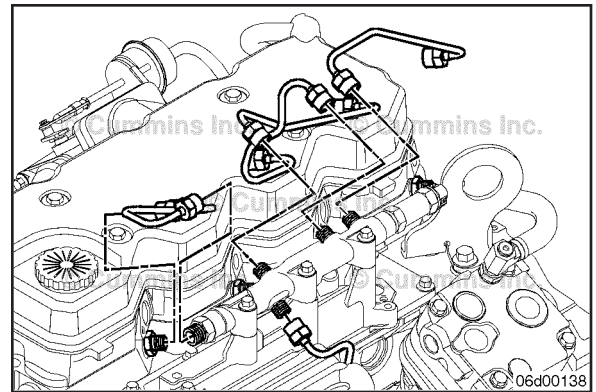

Tighten the injector supply line brace cap screws.
Torque Value: 24 N•m [212 in-lb]
Tighten the capscrews for the fuel rail.
Torque Value: 24 N•m [212 in-lb]

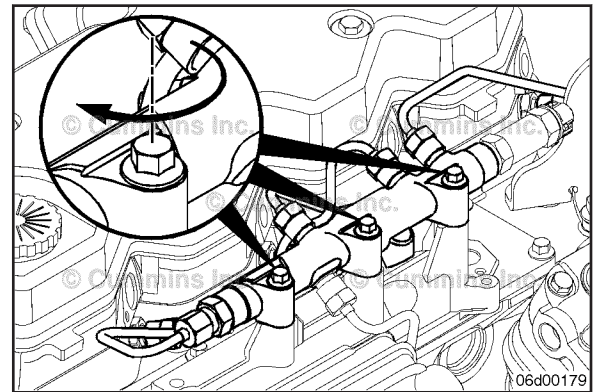

Air Intake Connection (010-080) Install

Automotive and Industrial

INITIAL CHECK: If replacing the air intake connection on engines equipped with EGR, check to make sure the EGR measurement venturi (1) is properly installed.

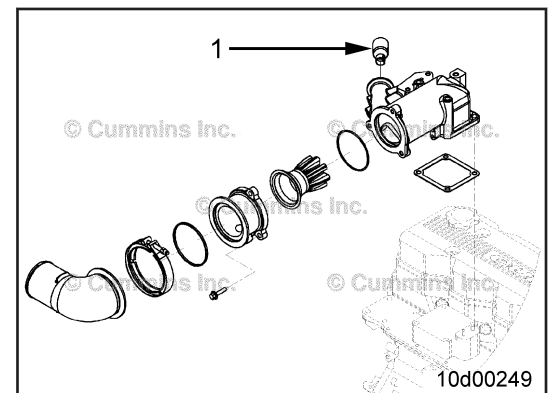

NOTE: The EGR measurement venturi (1) is a non-serviceable part. The air intake connection **must** be purchased with the EGR measurement venturi pre-installed.

Position the cold starting aid (if equipped) using new gaskets. Refer to Procedure 010-029 in Section 10.

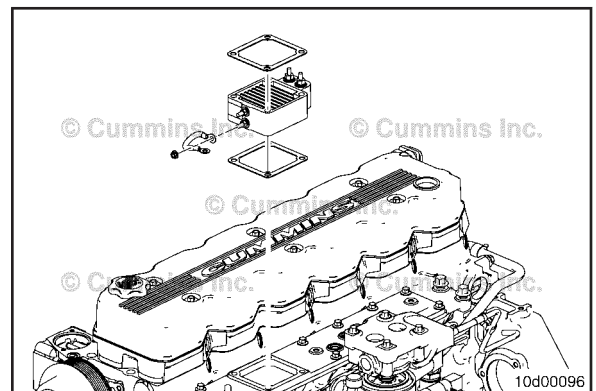

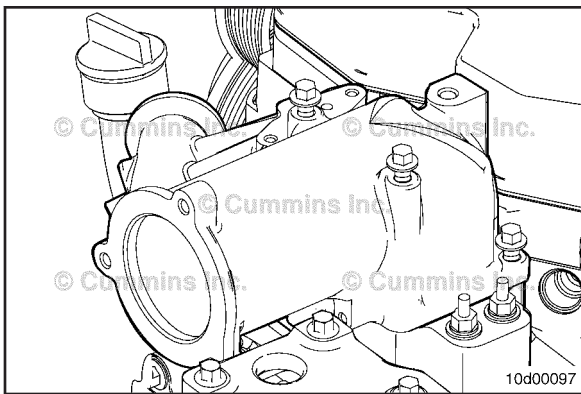

Install the air intake connection and four mounting screws.

If the engine is equipped with EGR, leave the four capscrews loose at this point. This will help minimize assembly stress on the attaching EGR connection tube to be installed next.

If the engine is **not** equipped with EGR, go to the step referencing tightening the four capscrews.

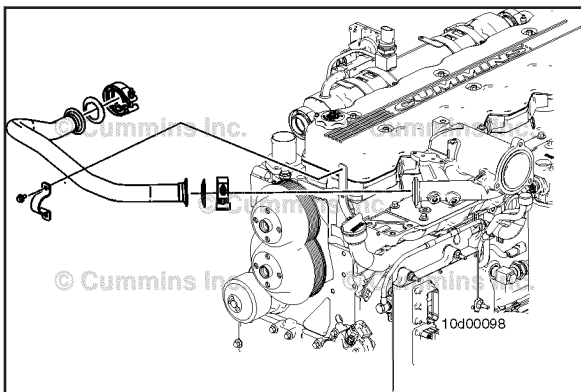

If the engine is equipped with EGR, position the air intake connection so that the Marmon™ flange meets the tube flare connection correctly.



Install the EGR connection tube. Refer to Procedure 011-025 in Section 11.

Tighten the V-band clamps.

Torque Value: 11 N•m [97 in-lb]

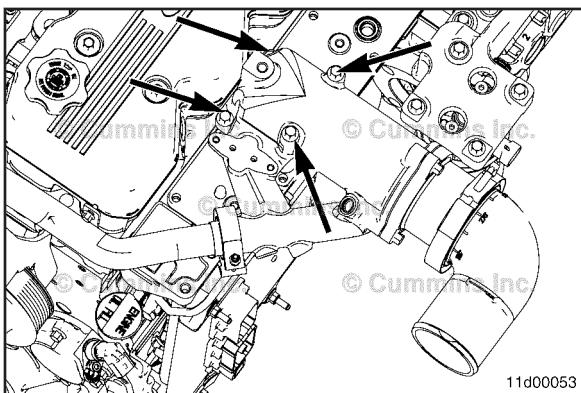

Tighten the four capscrews on the air intake connection.

Torque Value: 24 N•m [212 in-lb]

NOTE: Some air intake connections may **not** have an EGR connection as shown.

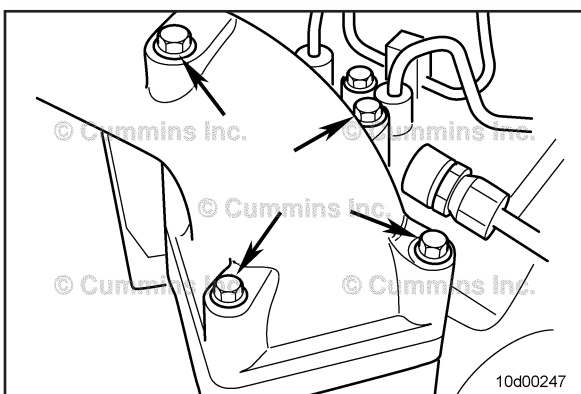

Marine Applications

Install the rear connection on the aftercooler assembly with a new gasket and the four mounting capscrews.



Tighten the capscrews.

Torque Value: 15 N•m [133 in-lb]

Install the front portion of the air intake connection and the four capscrews.

Tighten the capscrews.

Torque Value: 15 N•m [133 in-lb]

Tighten the hose clamps.

Torque Value: 8 N•m [71 in-lb]

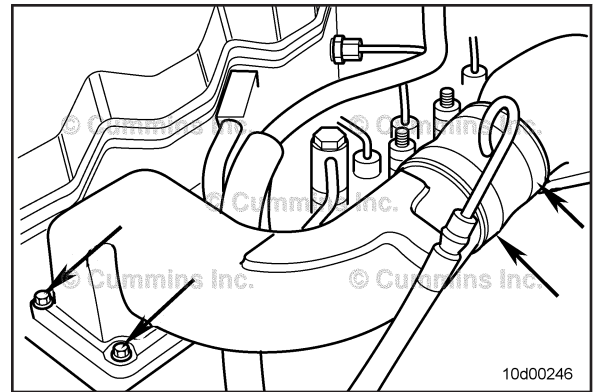

Air Intake Connection Adapter (010-131)

Install

Install the air intake connection adapter straight piece and seal to the air intake connection.

Service Tip: If the EGR mixer was removed, make sure it is installed before tightening the capscrews.

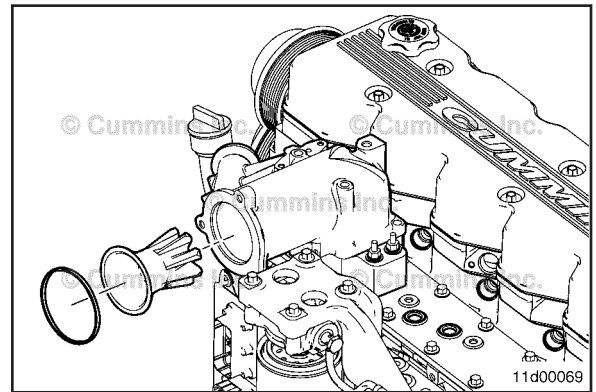

Tighten the three capscrews.

Torque Value: 24 N•m [212 in-lb]

Install the air compressor intake line from the adapter (if applicable).

Install the seal, air intake connection adapter elbow, and V-band clamp.

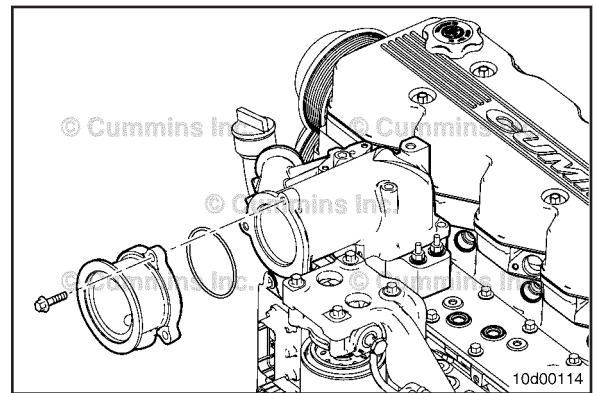

Tighten the V-band clamp.

Torque Value: 8 N•m [71 in-lb]

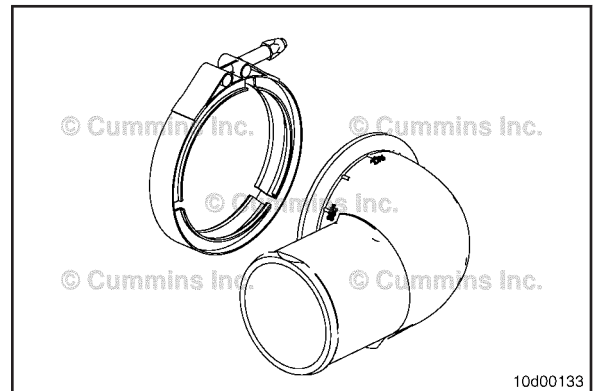

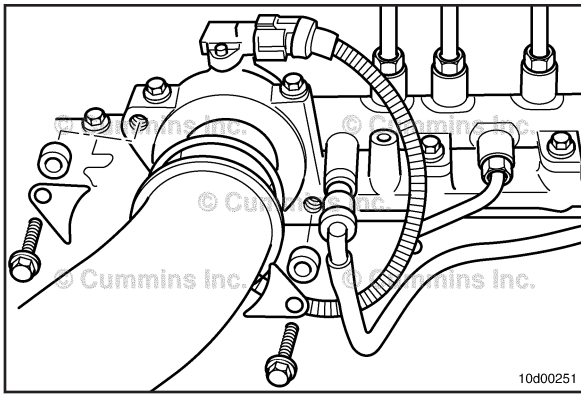

Install the seal, air intake connection adapter, and v-band clamp.



Tighten the v-band clamp.

Torque Value: 10 N•m [89 in-lb]

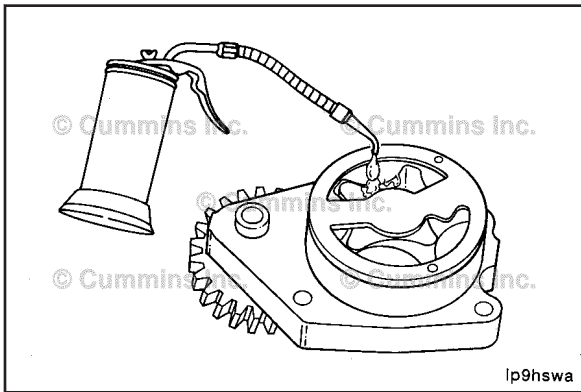

Lubricating Oil Pump (007-031) Install

⚠CAUTION⚠

Failure to fill the pump with oil during installation can result in a slow prime at initial engine start-up, resulting in severe engine damage.

Lubricate the lubricating oil pump with clean 15W-40 engine oil.

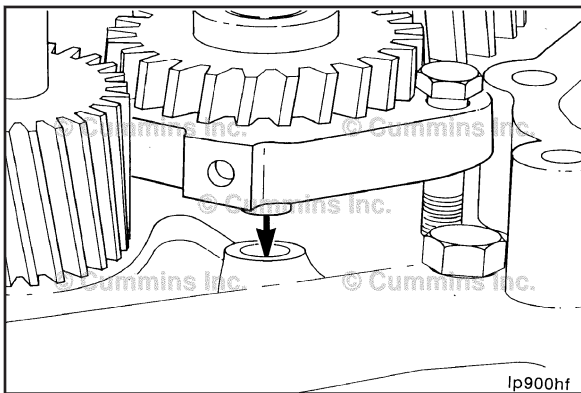

⚠CAUTION⚠

To reduce the possibility of engine damage, make sure the idler gear pin is installed in the locating bore in the cylinder block.

Install the lubricating oil pump.

NOTE: If installing a new lubricating oil pump ensure that the pump is correct for your engine. For example, lubricating oil pumps for 4 and 6 cylinder engines are physically interchangeable, but have different flow characteristics.

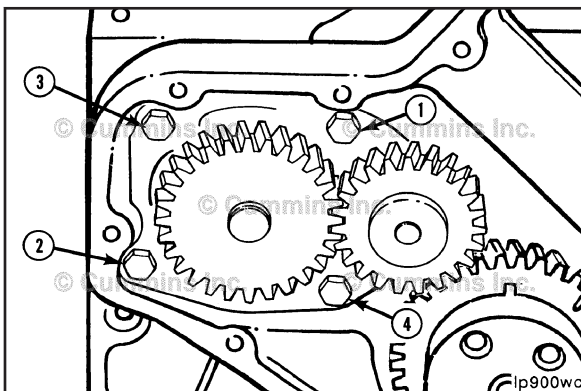

Using the sequence shown, torque the capscrews in the following sequence:

Initial Torque

Torque Value: 8 N•m [70 in-lb]

Final Torque

Torque Value: 24 N•m [212 in-lb]

NOTE: The back plate on the pump seats against the bottom of the bore in the cylinder block. When the lubricating oil pump is correctly installed, the flange on the lubricating oil pump will **not** touch the cylinder block.

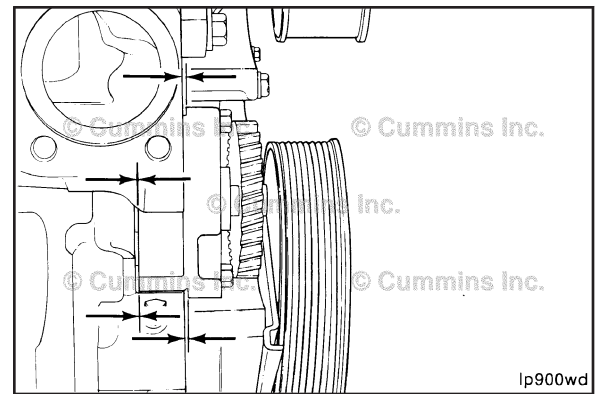

NOTE: Be sure the gear backlash is correct if installing a new lubricating oil pump.

Measure the gear backlash.

Backlash Limits (new pump)

	mm		in
A	0.300	MIN	0.011
	0.500	MAX	0.019
B	0.150	MIN	0.005
	0.250	MAX	0.009

NOTE: If you are reinstalling a used pump and have already measured the backlash you do **not** need to complete this step.

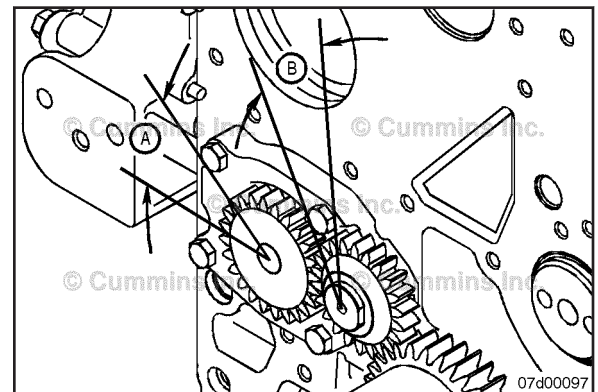

Gear Cover, Front (001-031)

Install

Rear Gear Train

Oil Pan Suspended - Rubber Gasket

Inspect the oil pan gasket for damage.

If the engine is equipped with a suspended oil pan with a rubber oil pan gasket and the gasket is found to be damaged, the oil pan **must** be removed and the entire oil pan gasket replaced. Refer to Procedure 007-025 in Section 7.

Oil Pan - Formed in Place Gasket

Remove the old sealant and apply new sealant, Part Number 3164070, to the oil pan mounting flange.

Oil Pan, Standard - Paper Gasket

Inspect the oil pan gasket for damage.

If the paper gasket is torn, it can be repaired.

Cut the torn gasket off even with the front of the cylinder block.

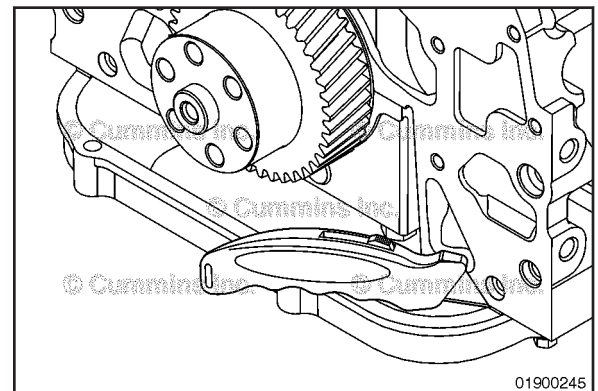

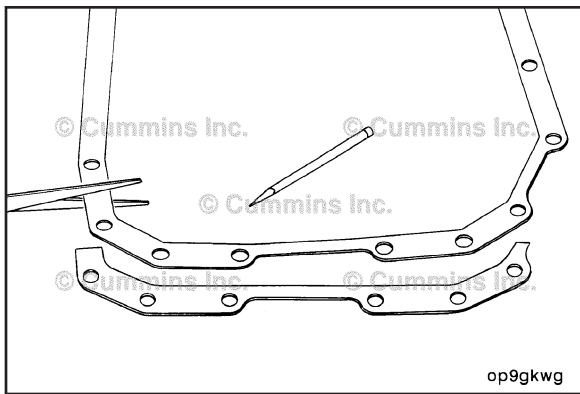

NOTE: Install three guide pins, Part Number 3164977, to improve alignment of the front cover and front seal to the gear housing and crankshaft.

Use the old gasket as a pattern to cut the front section of the new gasket to the same size.

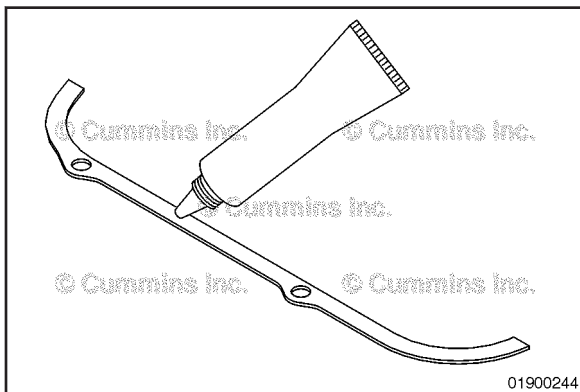

NOTE: The front gear cover **must** be installed within 10 minutes of applying the sealant.

Clean the sealing surfaces.

Coat the new gasket on both sides with sealant, Part Number 3164067.

Make sure there is a bead of sealant at the intersecting joint of the cylinder block, oil pan, and front gear cover.

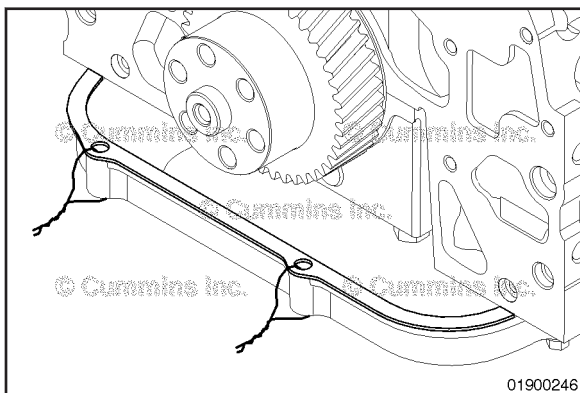

Use common thread or very fine wire to hold the gasket splice in position as illustrated.

⚠ CAUTION ⚠

When applying sealant to engines that have an oil pressure sensor/switch mounted in the front gear cover, do **NOT** block the oil feed between the cylinder block and front gear cover with sealant. This will result in the ECM indicating a low oil pressure fault and possible engine shutdown.

Apply a 1.5 to 2.0 mm [0.06 to 0.08 in] wide bead of sealant, Part Number 3164070, to the block side of the front gear cover in the path illustrated.

On engines equipped with an oil pressure sensor/switch located in the front gear cover, there are two critical sealant paths that **must** be followed:

1. In this area, the sealant **must** be applied towards the outer edge of the front gear cover to avoid an unused mounting hole in the cylinder block.

NOTE: To make sure the unused mounting hole in the cylinder block does not affect the sealing joint, fill the mounting hole with sealant, Part Number 3164070.

2. Sealant **must** be applied around both the mounting hole location, and the oil supply hole in the front gear cover.

NOTE: Install the front cover within 10 minutes of applying the sealant, or the sealant will **not** seal correctly. Once installed, allow the sealant to dry for 30 minutes before operating the engine.

NOTE: Before installing the front gear cover, make sure sealant, Part Number 3164067, has been applied to the intersecting joint of the cylinder block, oil pan, and front gear cover.

Use the dowel rings to locate the front gear cover and install the front gear cover onto the cylinder block.

Install the front gear cover to the cylinder block mounting capscrews and the oil pan to the front gear cover mounting capscrews. Do **not** tighten the capscrews at this time.

If installed, remove the thread or wire holding the oil pan paper gasket in place.

Tighten the front gear cover to the cylinder block mounting capscrews in the order indicated.

Tighten the oil pan to front gear cover mounting capscrews, starting with the inner capscrews first.

NOTE: Depending on the type of lubricating oil pan, there are two or four mounting capscrews.

Torque Value: 24 N·m [212 in-lb]

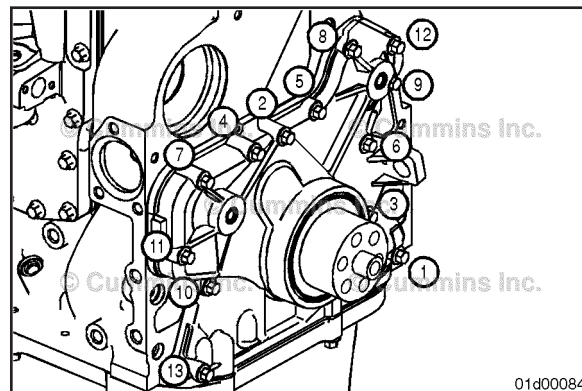
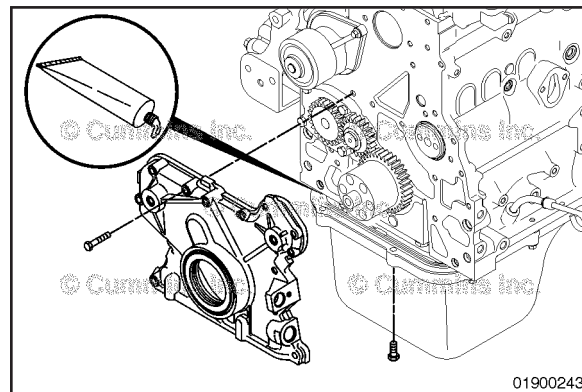
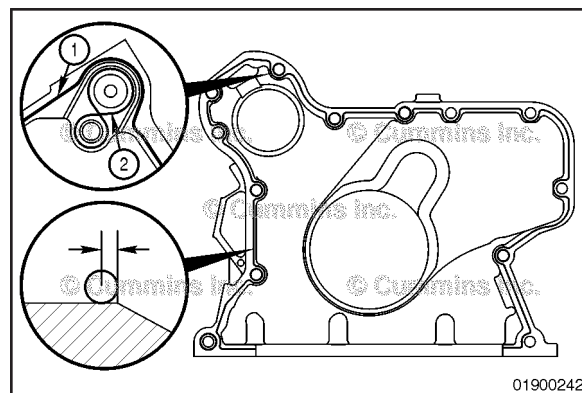

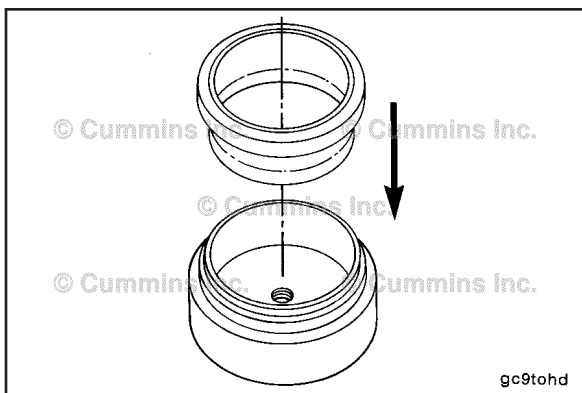

Crankshaft Seal, Front (001-023)

Install

Leave the plastic pilot installation tool in the front crankshaft seal.

Position the seal on the seal installation tool, Part Number 3824498, with the seal dust lip facing outward.

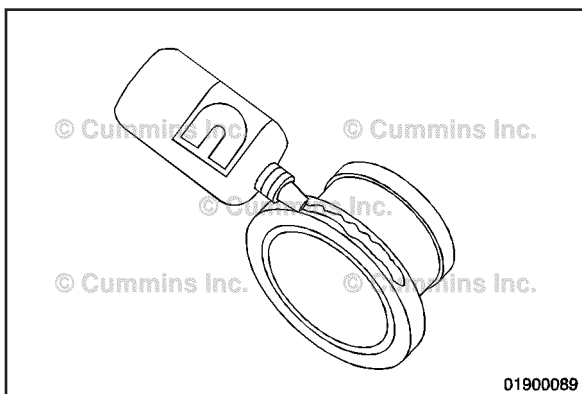

Apply a bead of sealant, Part Number 3824498, to the outside circumference of the seal.

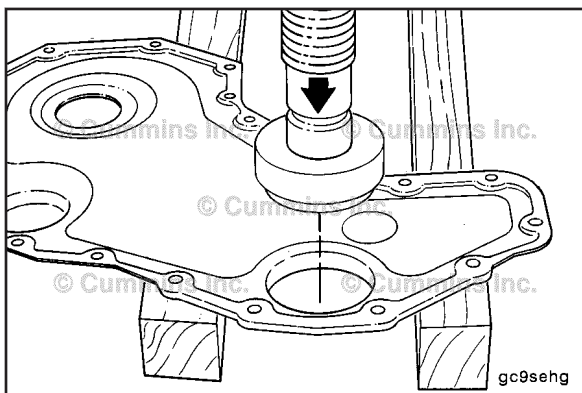

⚠ CAUTION ⚠

Properly support the front cover lubricating oil seal flange to prevent damage to the lubricating oil seal and front cover.

Press the lubricating oil seal into the front cover from the backside of the cover toward the frontside of the cover.

Press the lubricating oil seal until the oil seal installation tool, Part Number 3824498, bottoms against the front cover.

NOTE: Each front crankshaft seal kit comes with an installation tool. This tool can be used in place of front crankshaft seal installation tool, Part No. 3824498, if **not** available. Using a mallet, tap around the installation tool to drive the front crankshaft seal into the front gear cover until the installation tool bottoms against the front gear cover.

The seal lip and the sealing surface on the crankshaft **must** be free from all oil residue to prevent seal leaks.

Apply a thin bead of sealant, Part Number 3164070, to the sealing surface of the front cover.

NOTE: Do **not** remove the plastic seal pilot tool from the front crankshaft seal at this time. Use the plastic seal pilot tool to guide the seal on the crankshaft.

NOTE: Install the front cover within 10 minutes of applying the sealant, or the sealant will **not** seal correctly. Once installed, allow the sealant to dry for 30 minutes before running the engine.

Install the front gear cover on the engine, using the plastic seal pilot tool to guide the front crankshaft seal onto the crankshaft.

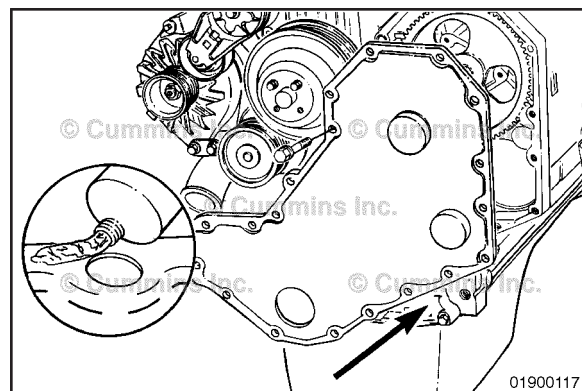

Install and tighten the front gear cover capscrews in the order indicated.

Torque Value: 24 N•m [18 ft-lb]

Remove the plastic pilot tool from the crankshaft.

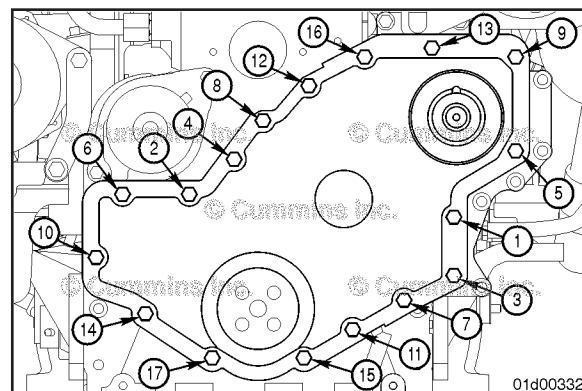

If previously equipped or if the engine operates in a dusty environment, install a dust seal.

A pilot tool is not necessary for the dust seal. Slide the dust seal over the nose of the crankshaft.

Use the installation tool that came with the new front crankshaft seal to install the dust seal into the front gear cover. Install the dust seal until it is even with the front gear cover.

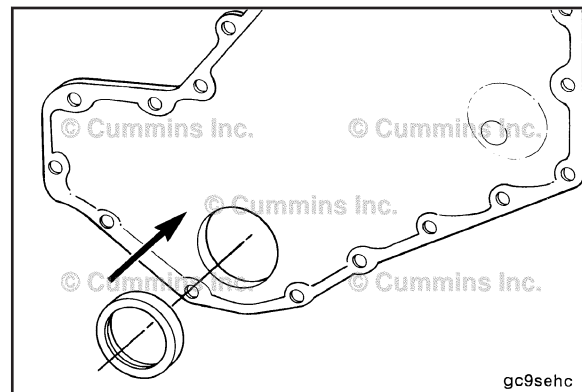

Use tool, Part Number 3164659, to install the oil seal into the front gear cover.

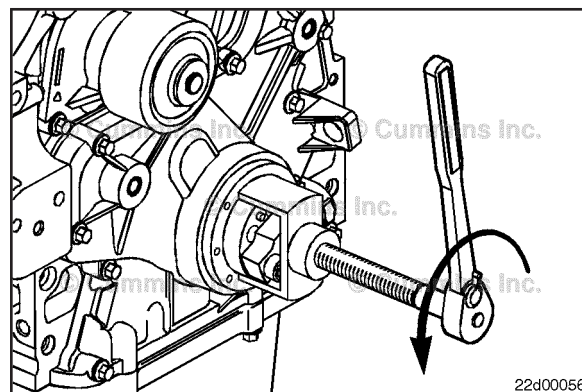

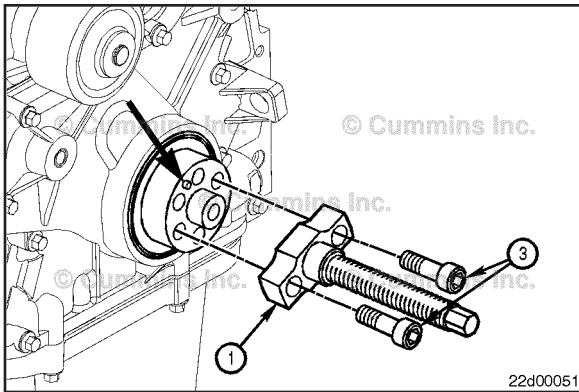

Mount the replacer screw assembly (1) onto the crankshaft nose.

Install the two M12 x 1.25 x 60 mm socket head capscrews (3).

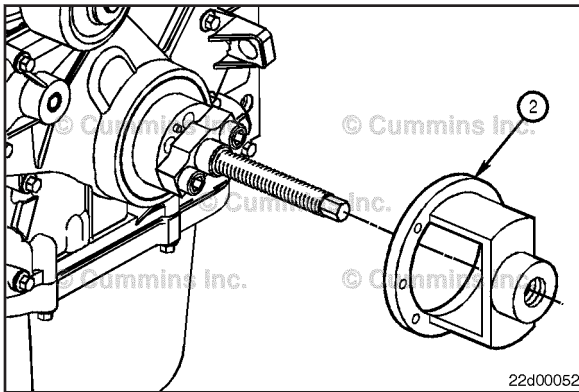

⚠ CAUTION ⚠

Do not use an impact wrench or air tools. Doing so can damage the tool.

Place the new front crankshaft seal over the crankshaft nose and slide it by hand toward the front gear cover as far as possible.

NOTE: Make sure the seal is positioned squarely with the crankshaft.

While holding the replacer screw, install the crankshaft seal replacer (2) onto the replacer screw assembly.

Advance the crankshaft seal replacer toward the seal by rotating it **clockwise** until it is positioned against the seal.

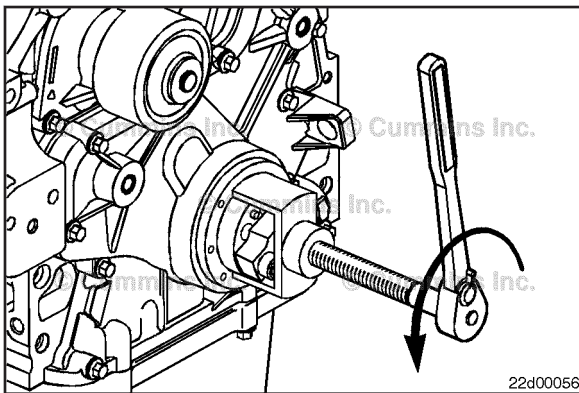

⚠ CAUTION ⚠

Do not overtighten the replacer screw assembly after the crankshaft seal replacer contacts the front cover. Doing so can damage the tool.



While holding the crankshaft seal replacer, rotate the replacer screw **counterclockwise** until the crankshaft seal replacer contacts the front gear cover.

Remove the service tools.

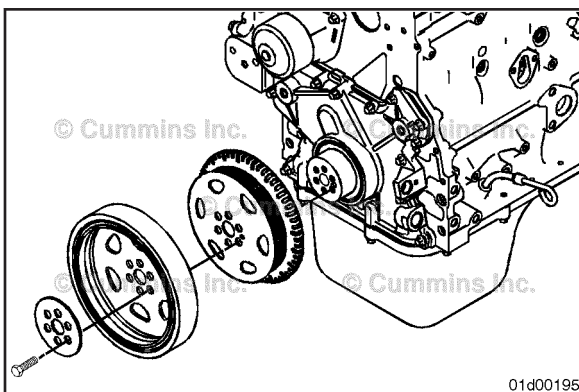

Crankshaft Speed Indicator Ring (001-071)

Install

If the engine is **not** equipped with a vibration damper, install the six capscrews that hold the crankshaft speed indicator ring/pulley to the nose of the crankshaft.

Tighten crankshaft speed indicator ring/pulley capscrews.

Torque Value:

Step 1 50 N•m [37 ft-lb]
Step 2 Rotate 90 degrees

Vibration Damper, Viscous (001-052)

Install

NOTE: Align the crankshaft speed indicator ring, and vibration damper with the index pin located on the nose of the crankshaft.

Lubricate bolts with clean engine oil.

Install the vibration damper and crankshaft speed indicator ring.

For front gear train engines, tighten the four damper capscrews in a criss-cross pattern.

Torque Value:

Step 1 40 N•m [30 ft-lb]
Step 2 Rotate 60 degrees

For rear gear train engines, tighten the six vibration damper capscrews in a criss-cross pattern.

Torque Value:

Step 1 50 N•m [37 ft-lb]
Step 2 Rotate 90 degrees

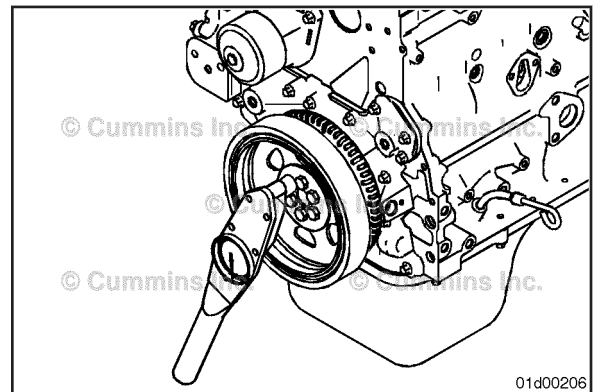
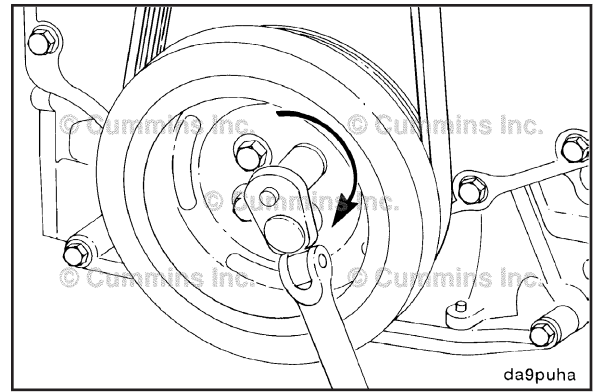

Vibration Damper, Rubber (001-051)

Install

NOTE: Align the crankshaft speed indicator ring, and vibration damper with the index pin located on the nose of the crankshaft.

Lubricate bolts with clean engine oil.

Install the vibration damper and crankshaft speed indicator ring.

For front gear train engines, tighten the four damper capscrews in a criss-cross pattern.

Torque Value:

Step 1 40 N•m [30 ft-lb]
Step 2 Rotate 60 degrees

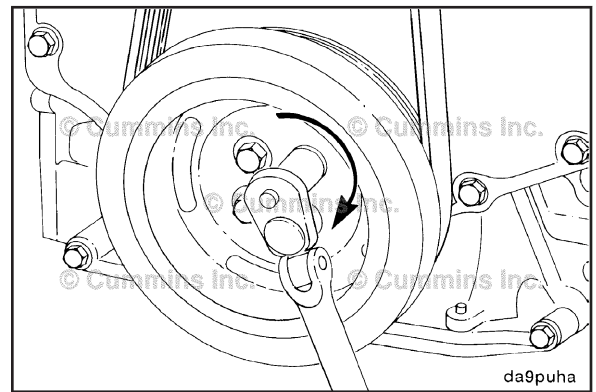

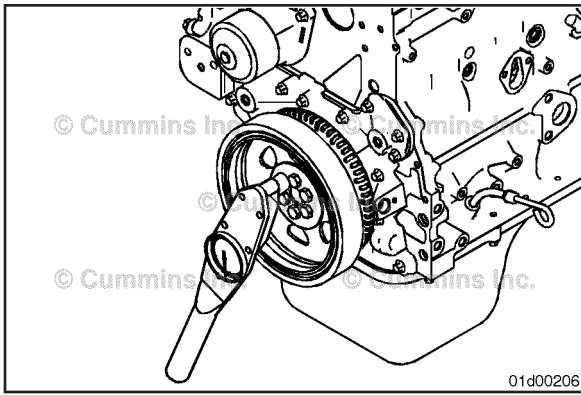

For rear gear train engines, tighten the six vibration damper capscrews in a criss-cross pattern.

Torque Value:

- Step 1 50 N•m [37 ft-lb]
Step 2 Rotate 90 degrees

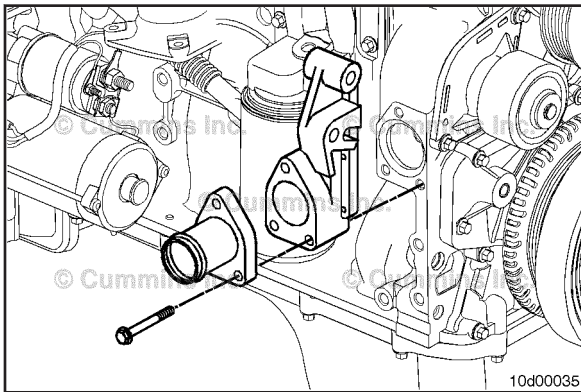

Water Inlet Connection (008-082)

Install



Install the capscrews, water inlet connection, gasket, and rectangular sealing ring.

Align the roll pins against the front face of the cylinder block and tighten the capscrews.

Torque Value:

- M10
Step 1 43 N•m [32 ft-lb]

Torque Value:

- M12
Step 1 80 N•m [59 ft-lb]

Install the coolant hoses.

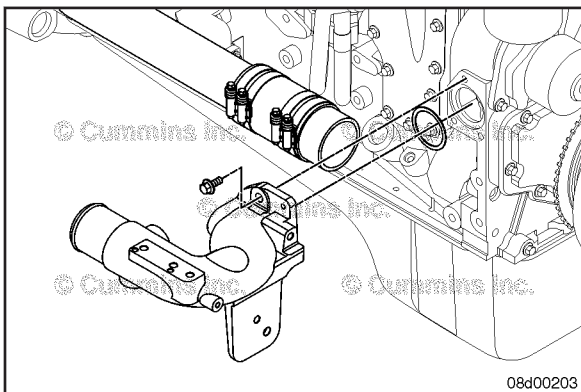

NOTE: The upper water inlet connection mounting capscrew is shorter than the two lower capscrews. Install the shorter capscrew in the upper mounting hole.



Install a new rectangular seal ring onto the engine block. A small amount of Lubriplate™ multi-purpose lubricant can be used to hold the ring in place.

Slide the water inlet connection into the hose connection of the coolant return junction until the mounting capscrew holes line up with the holes in the cylinder block and the dowel pins contact the front of the machined block surface. The dowel pins are for making sure of correct belt alignment.

Install the three mounting capscrews in the connection. Tighten the capscrews.

Torque Value: 43 N•m [32 ft-lb]

Slide the two hose clamps into place on the coolant return junction connection and tighten.

Torque Value: 8 N•m [71 in-lb]

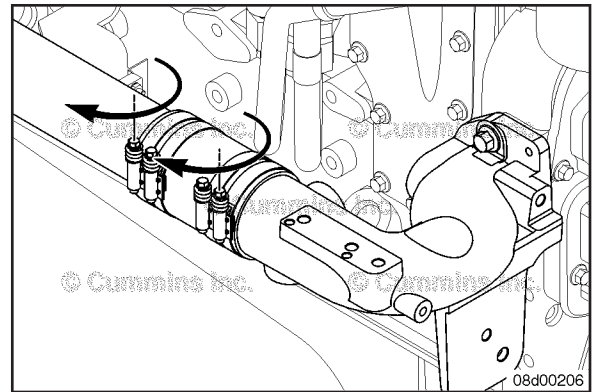

Water Pump (008-062) Install

Install a new sealing ring into the water pump groove.

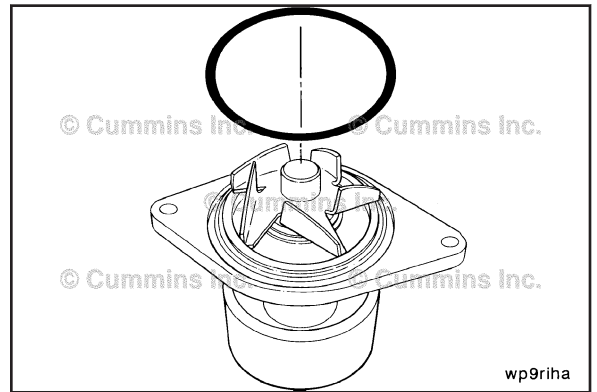

Install the water pump and mounting capscrews.
Tighten the capscrews.

Torque Value:
9.8 Grade 24 N•m [212 in-lb]

Torque Value:
10.9 Grade 30 N•m [22 ft-lb]

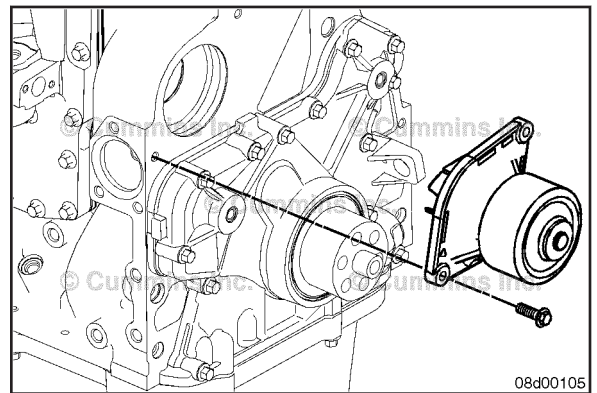

Crosshead (002-001) Install

NOTE: The crosshead has a round and oval hole. If installing new crossheads, it is **not** required to place the holes in a particular position. If crossheads are being reused, make sure to install them in their original location and orientation.

Install the crossheads on the valve stems.

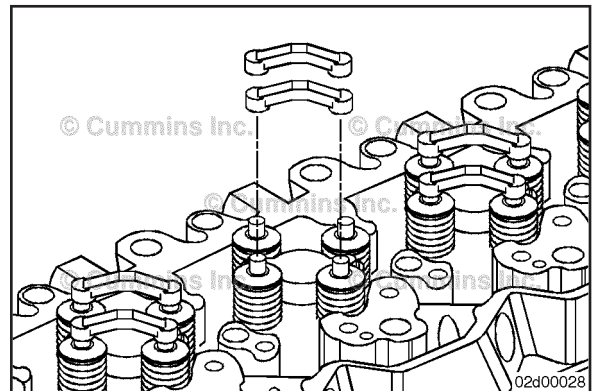

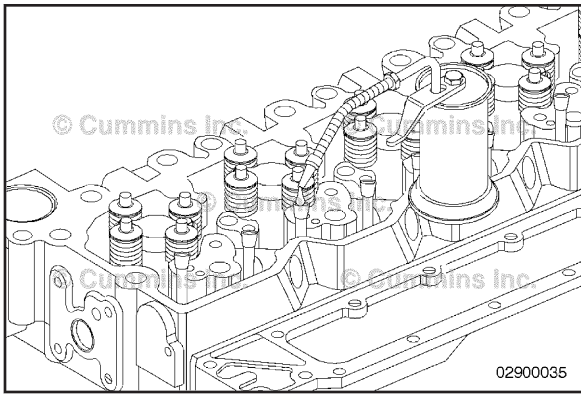

Push Rods or Tubes (004-014)

Install



Install the push rods into the sockets of the valve tappets.
Lubricate the push rod sockets with clean 15W-40 engine oil.

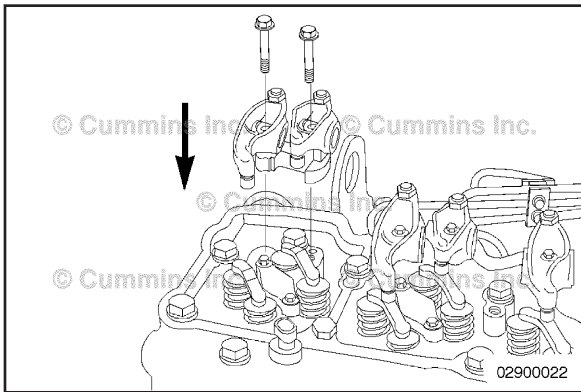

Install the crossheads and rocker levers. Refer to Procedure 003-008

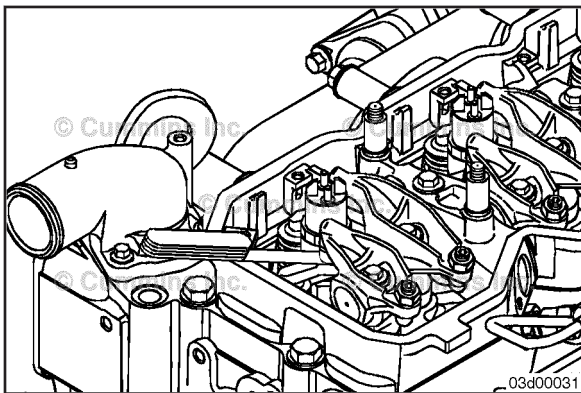

Adjust the valves. Refer to Procedure 003-004

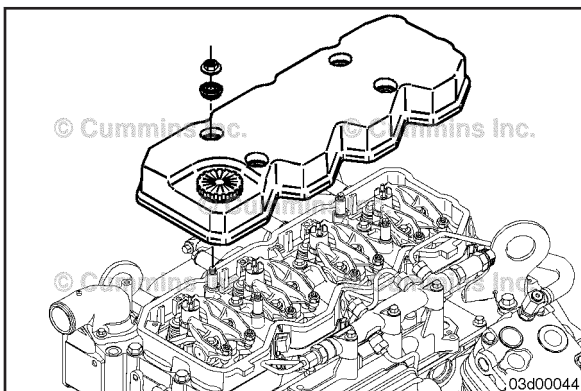

Install the rocker lever cover and gasket. Refer to Procedure 003-011



Rocker Lever (003-008)

Install

Install the rocker lever assemblies and pedestals in their original position.

Install the pedestal mounting capscrews.

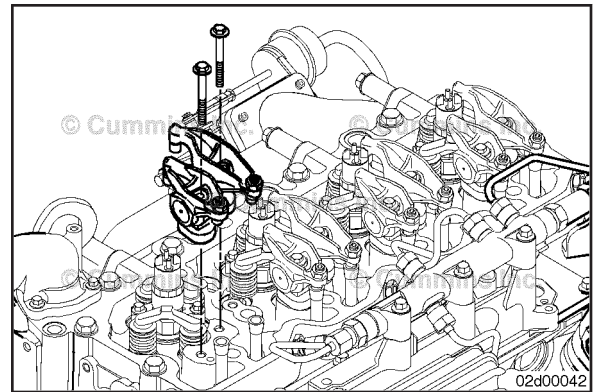

Tighten the pedestal mounting capscrews.

Torque Value: 36 N•m [27 ft-lb]

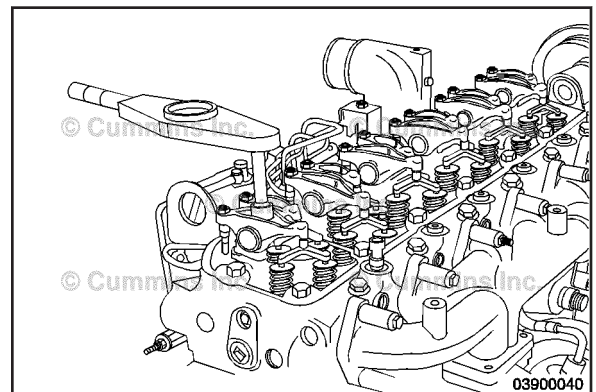

⚠ CAUTION ⚠

Rotate the adjusting screws until the adjusting screw contacts the socket of the push rod. This will ensure the push rod stays in contact with the tappet and adjusting screw when the engine is rotated to set valve lash. If not completed, the push rods may be bent or damaged.

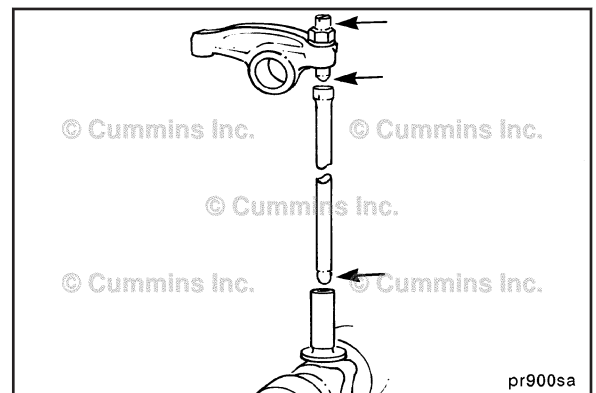

Rocker Lever Housing (003-013)

Install

⚠ CAUTION ⚠

Care must be taken when installing the gasket. Do not twist or stretch it. Failure to do so can result in an oil leak.

Install the rocker housing and a new rocker housing gasket, if removed.

Torque Value: 24 N•m [212 in-lb]

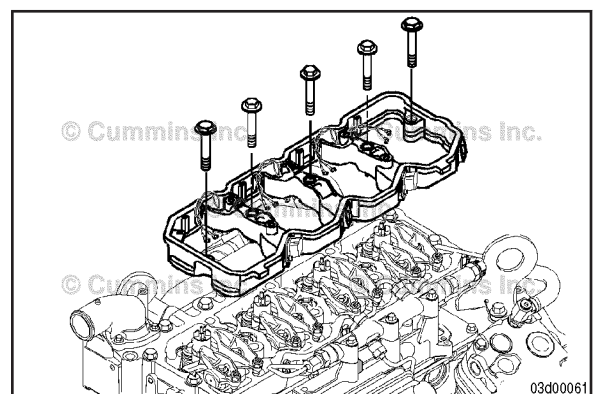

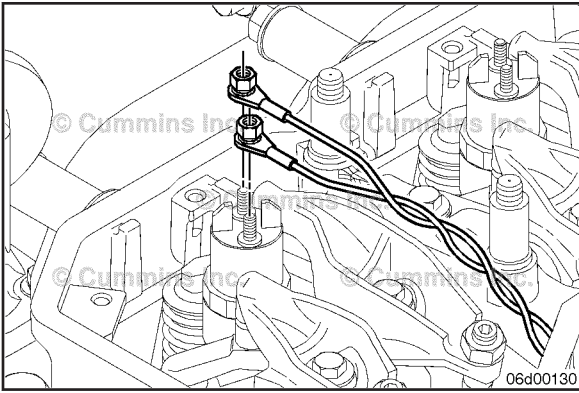

CAUTION

Overtightening of the injector wiring can cause damage to the injector.



Connect the injector wiring.

Use Cummins service tool, Part Number 3823208, or torque wrench.



Torque Value: 1.5 N•m [13 in-lb]

NOTE: If a torque wrench capable of 1.5 N•m [13 in-lb] is not available, then the following specification can be used. The alternate torque is finger-tighten with an additional 30-degree turn.

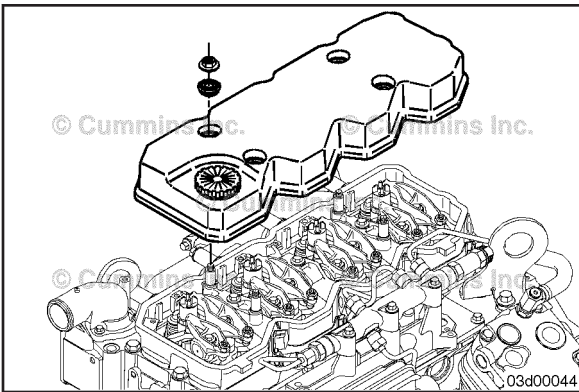

Install the rocker lever cover and gasket. Refer to Procedure 003-011

Torque Value: 24 N•m [212 in-lb]

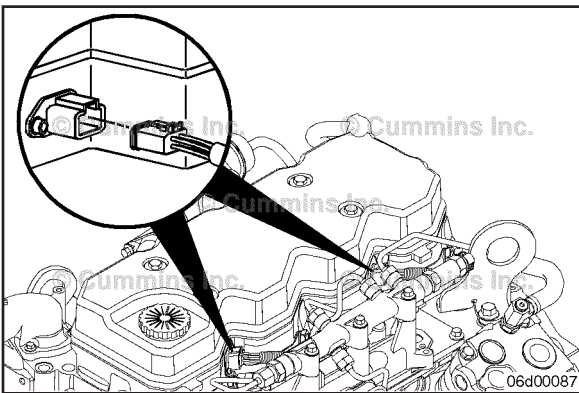

Connect the injector harness pass-through connector.

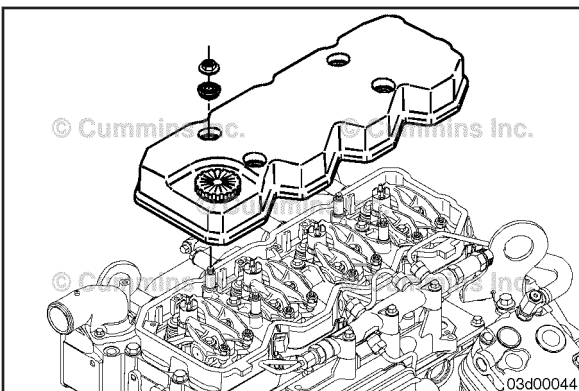

Rocker Lever Cover (003-011)

Install



Stud Mounted Rocker Lever Cover.

Install the rocker lever cover over the mounting capscrews.

Install the isolators and mounting nuts.

Tighten the mounting nuts.

Torque Value: 24 N•m [212 in-lb]

Capscrew Mounted Rocker Lever Cover.
Install the rocker lever cover.
Install the mounting capscrews and isolators.
Tighten the mounting capscrews.

Torque Value: 24 N•m [212 in-lb]

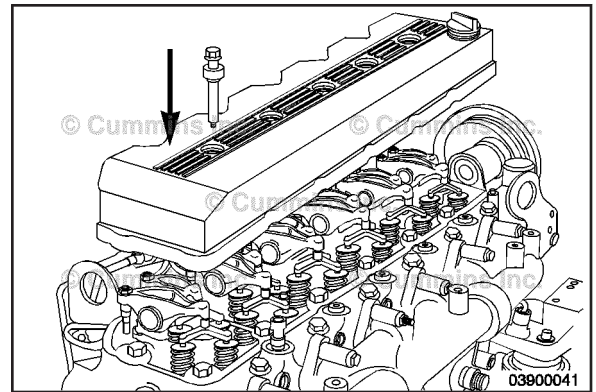

External Mounted Crankcase Breather.
Connect the crankcase breather tube to the crankcase breather assembly.
Connect the crankcase breather oil drain line to the crankcase breather assembly.

NOTE: It may be necessary to install an engine cover previously removed. Refer to the OEM instructions.

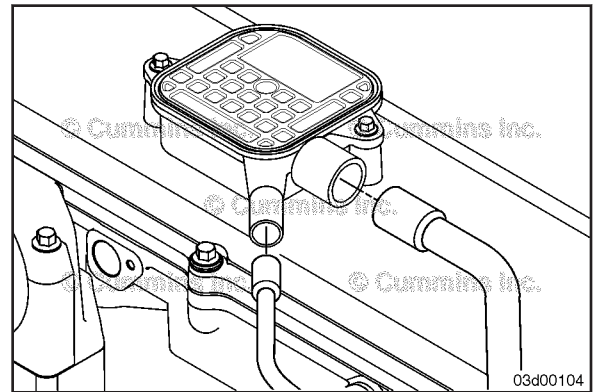

Internal Mounted Crankcase Breather.
If equipped, at the rear of the rocker lever cover install the banjo bolt and sealing washers connecting the breather oil drain line to the rocker lever cover.

Torque Value: 12 N•m [106 in-lb]

NOTE: Not all engines with an internal mounted crankcase breather are equipped with an external breather oil drain line. On some engines the breather oil drain line is internal to the breather connection tube (1).

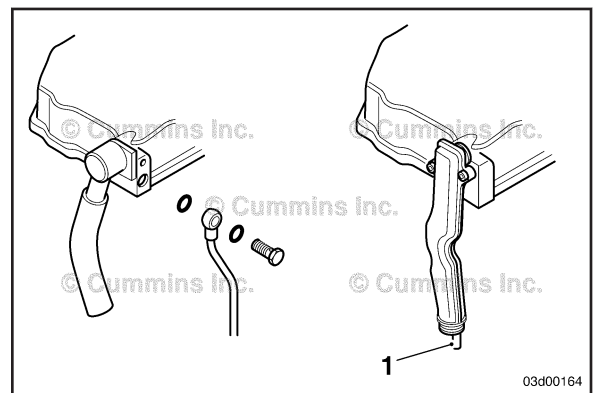

Prior to connecting the breather connection tube to the rocker lever cover, apply clean engine oil to the o-ring located on the breather tube connection.

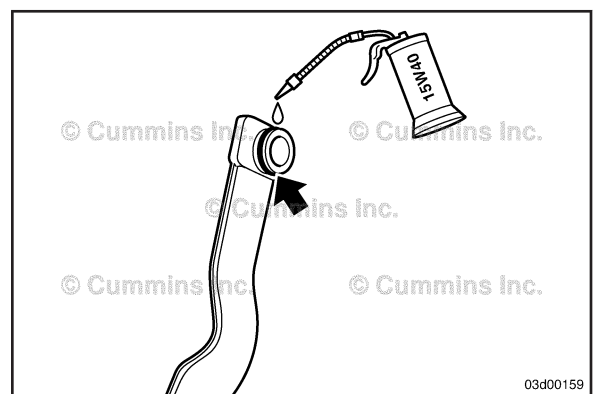

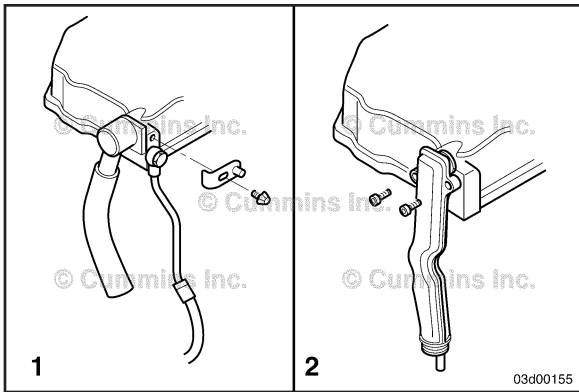

Connect the breather tube connection to the rocker lever cover.

In general, two types of breather tube connections are used at the rocker lever cover:

- 1 A clamping plate and capscrew hold the breather tube connection to the rocker lever cover. Install the capscrew and clamping plate to connect the breather tube connection to the rocker lever cover.
- 2 One or two capscrew(s) directly mount the breather tube connection to the rocker lever cover. Install the capscrew(s) to connect the breather tube connection to the rocker lever cover.

Tighten the capscrew(s).

Torque Value: 10 N•m [89 in-lb]

NOTE: Some breather tube connections use internal torx capscrews to secure the breather tube connection to the rocker lever cover.

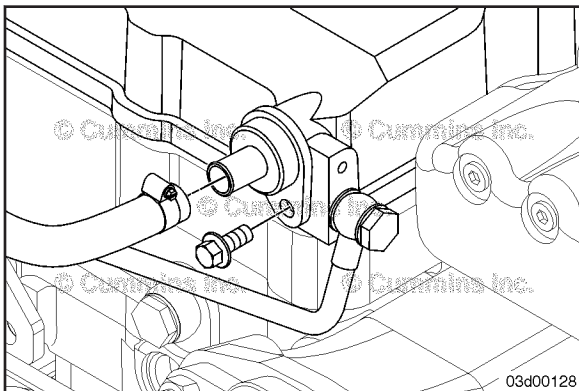

Marine Applications

Open Draft Tube Type

For the open draft tube type, install the cover plate and mounting capscrew.



Tighten the mounting capscrew.

Torque Value: 7 N•m [62 in-lb]

Install the crankcase breather tube and spring clamp.

Install the banjo bolt and sealing washers connecting the breather oil drain line to the rocker lever cover.

Tighten the banjo bolt.

Torque Value: 12 N•m [106 in-lb]

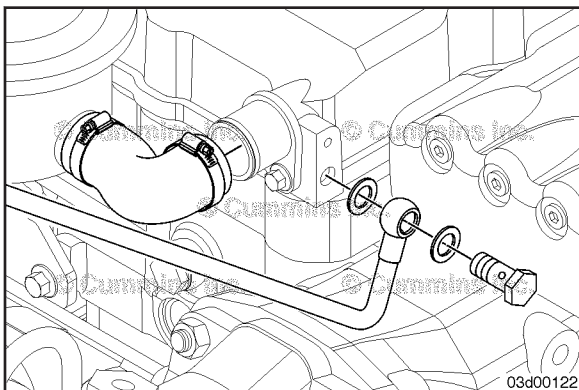

Closed Draft Tube Type

Connect the closed crankcase breather system hose to the rocker lever cover breather port.



Tighten the hose clamps.

Torque Value: 6 N•m [53 in-lb]

For the closed draft tube type, install the banjo bolt and sealing washer connecting the breather oil drain line to the rocker lever cover.

Tighten the banjo bolt.

Torque Value: 12 N•m [106 in-lb]

Crankcase Breather (External) (003-001)



Install

Install the capscrews, cover plate and new gasket to the cylinder block.

Torque Value: 24 N•m [18 ft-lb]

Connect the breather oil drain line to the drain fitting on the cylinder block mounted cover plate.

Route the breather oil drain line to the crankcase breather mounting location.

If equipped, install any p-clips removed that secure the breather oil drain line.

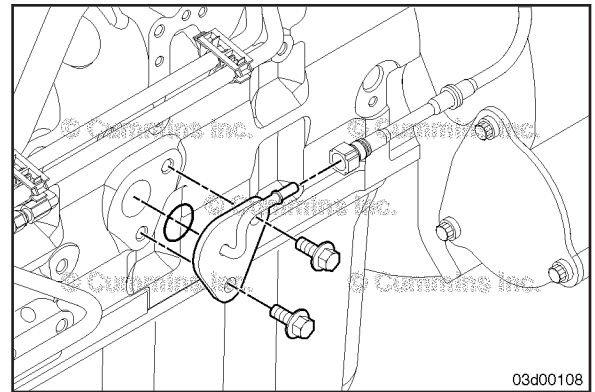

Install the breather and mounting capscrews into the rocker lever cover.

Lubricate the o-ring and the rocker lever valve cover with lubricating oil.

Tighten the capscrews.

Torque Value: 10 N•m [89 in-lb]

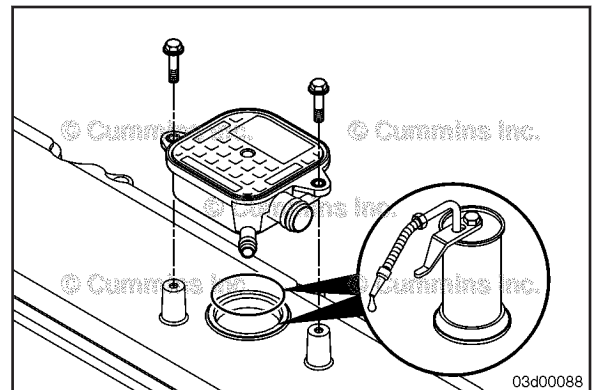

Connect the crankcase breather tube to the crankcase breather assembly.

Connect the crankcase breather oil drain line to the crankcase breather assembly.

NOTE: It may be necessary to install an engine cover previously removed. Refer to the OEM instructions.

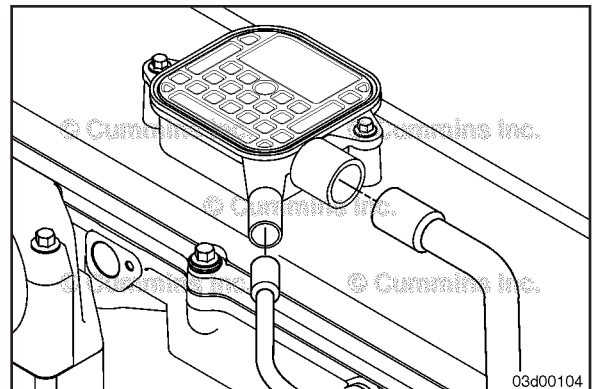

Crankcase Breather (Internal) (003-002)



Install

Prior to installing the breather connection tube, apply clean engine oil to the o-ring(s) located on the breather tube connection.

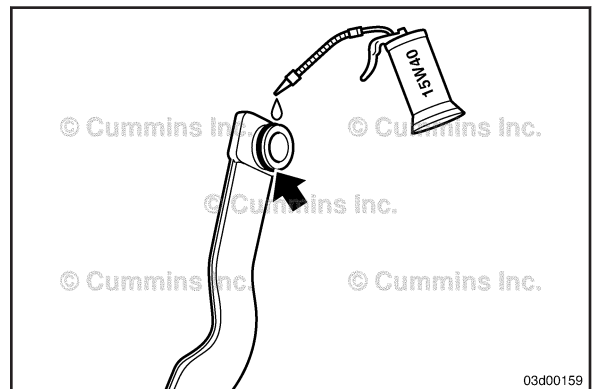

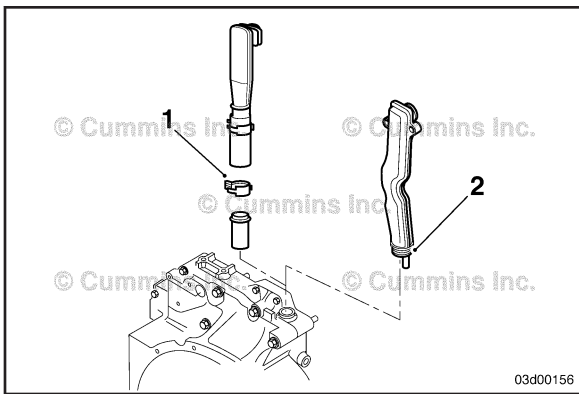

Install the breather tube connection into the rear gear housing.

In general, two type of breather tube connections are used at the rear gear housing:

- 1 An o'ring sealed connection. Install the breather tube connection by inserting the breather tube connection into the rear gear housing until fully seated
- 2 A clamped hose. Install the breather tube connection hose onto the inlet at the rear gear housing and install/tighten the clamp.

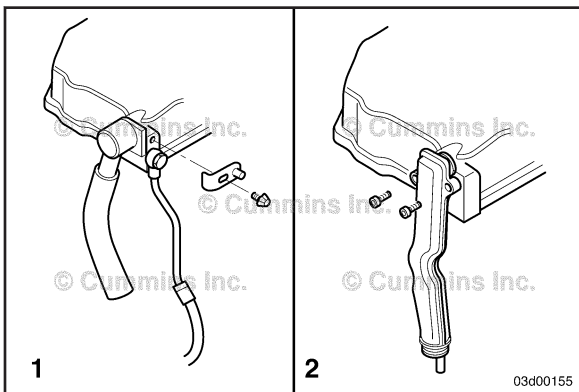

Connect the breather tube connection to the rocker lever cover.

In general, two types of breather tube connections are used at the rocker lever cover:

- 1 A clamping plate and capscrew hold the breather tube connection to the rocker lever cover. Install the capscrew and clamping plate to connect the breather tube connection to the rocker lever cover.
- 2 1 or 2 Capscrew(s) directly mount the breather tube connection to the rocker lever cover. Install the capscrew(s) to connect the breather tube connection to the rocker lever cover.

Tighten the Capscrew(s).

Torque Value: 10 N•m [89 in-lb]

NOTE: Some breather tube connections use internal torx capscrews to secure the breather tube connection to the rocker lever cover.

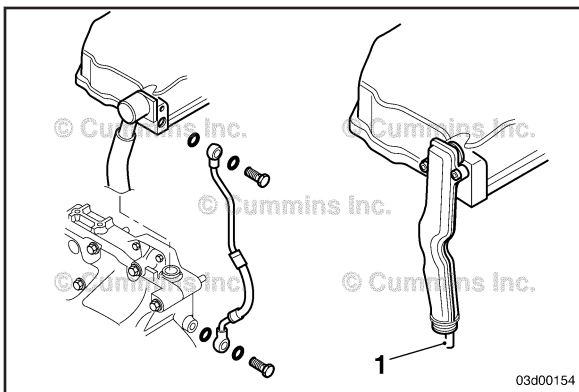

If equipped, install the breather oil drain line.

First, at the rear of the rocker lever cover, install the banjo bolt and sealing washers connecting the breather oil drain line to the rocker lever cover.

Torque Value: 12 N•m [106 in-lb]

Second, at the rear of the engine on the exhaust side, install the banjo bolt and sealing washers connecting the breather oil drain line to the rear gear housing.

Torque Value: 12 N•m [106 in-lb]

NOTE: Not all engines with an internal mounted crankcase breather are equipped with an external breather oil drain line. On some engines the breather oil drain line is internal to the breather connection tube (1).

Install a new gasket and the check valve connection to the side of the engine block.

Tighten the capscrews.

Torque Value: 24 N•m [18 ft-lb]

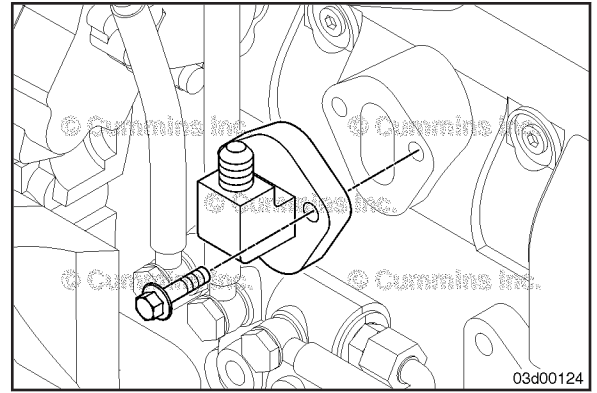

Connect the breather oil drain back tube fitting to the check valve.

Torque Value: 30 N•m [26 ft-lb]

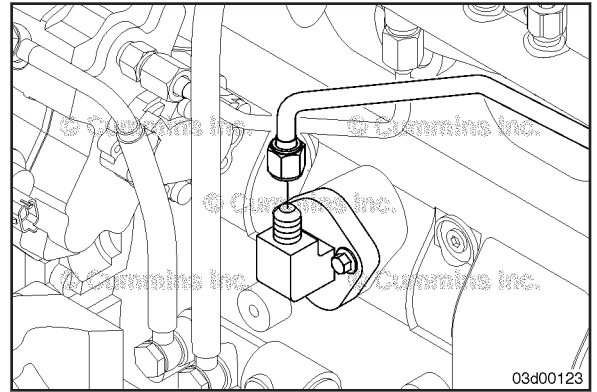

Connect the closed crankcase breather system hose to the rocker lever cover breather port.

Tighten the hose clamps.

Torque Value: 6 N•m [53 in-lb]

Install the banjo bolt and sealing washers connecting the breather oil drain line to the rocker lever cover.

Torque Value: 12 N•m [106 in-lb]

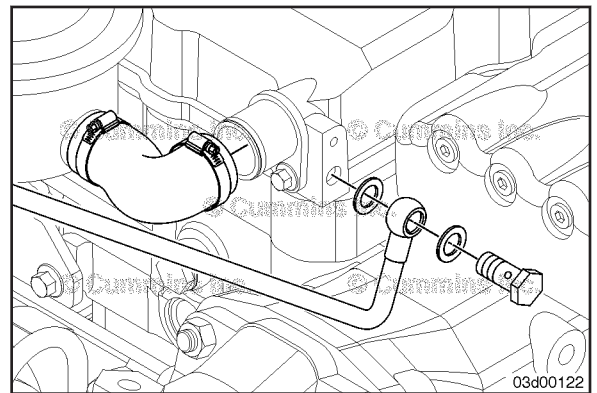

Install the p-clamp around the breather oil drain back tube to the side of the engine block.

Torque Value: 24 N•m [18 ft-lb]

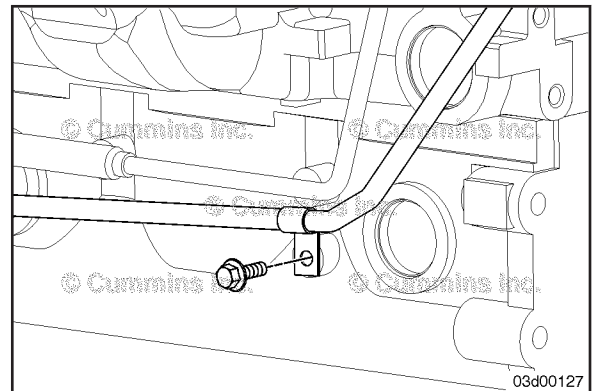

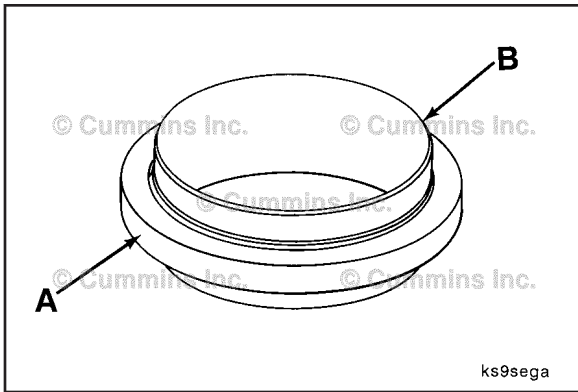

Crankshaft Wear Sleeve, Rear (001-067)

Install

NOTE: For engines equipped with a wet flywheel housing, make sure to replace the rear crankshaft seal with the correct rear seal. Rear crankshaft seals for a wet and dry flywheel housings may **not** be the same.

NOTE: The replacement oversize seal may appear different than the standard size seal.

⚠CAUTION⚠

The new rear crankshaft seal should not be removed from the crankshaft rear seal wear sleeve. Damage to the sealing lips may occur when reinstalling the seal onto the wear sleeve.

The new oversize seal and wear sleeve comes preassembled and will be installed on the crankshaft as an assembly.

- Crankshaft oil seal
- Wear sleeve.

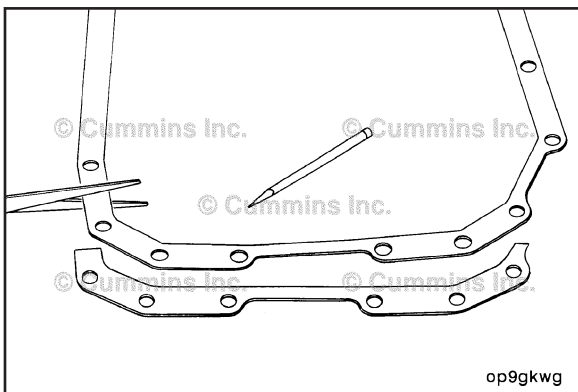

Service Tip: If the oil pan gasket was damaged during removal of the rear seal carrier, remove the damaged gasket and:

- 1 If previously equipped with a paper oil pan gasket, use the old gasket as a pattern and cut a section of a new gasket to the same size. Use a light coat of sealant, Part Number 3164067, to hold the gasket in place
- 2 If previously equipped with a sealant only oil pan gasket, apply a bead of sealant, Part Number 3164070, to the oil pan flange
- 3 If previously equipped with a suspended oil pan, the oil pan must be removed and a new gasket installed. Refer to Procedure Procedure 007-025

NOTE: The rear seal carrier **must** be installed within 10 minutes of applying the sealant.

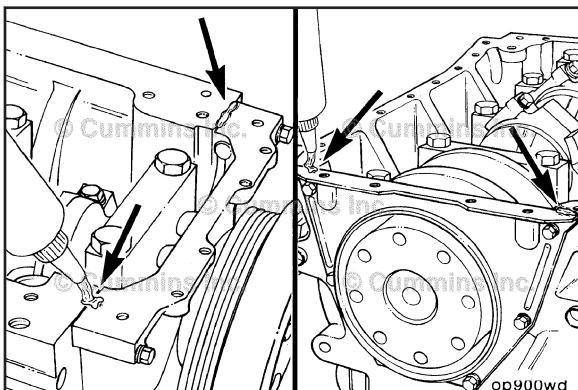

NOTE: If the oil pan is installed, it may be necessary to loosen additional oil pan capscrews to allow clearance for rear seal carrier and gasket clearance.

NOTE: It may be necessary to trim the rear seal carrier gasket so that it is even with the oil pan mounting surface. Also, apply a thin bead of sealant, part number 3164067, at this joint prior to installing the rear seal carrier. The rear seal carrier **must** be installed within 10 minutes of applying the sealant.

Install the rear seal carrier, mounting capscrews and gasket.

Loosely tighten the rear seal carrier mounting capscrews at this time.

NOTE: The seal installation will properly align the rear seal carrier.

To aid in installation, the lubricating oil seal requires the application of a mild soap on the outside diameter of the seal case.

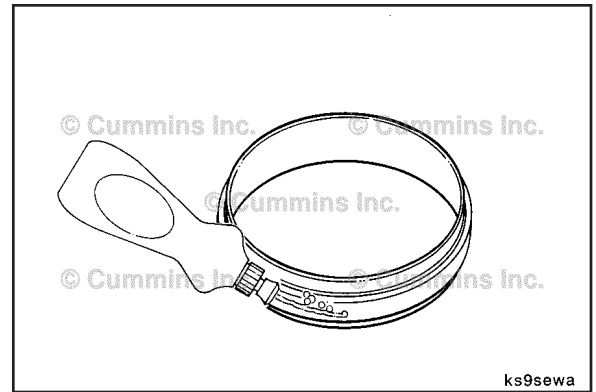

Use service tool, Part Number 3824078, to install the crankshaft seal/wear sleeve assembly.



Reference Number	Part Number	Description
1	3163734	Plate
2	3163628	Stud
3	3163741	Hex Nut

Install two (2) threaded studs into the crankshaft capscrew holes.

Apply a small amount of clean 15W-40 engine oil to the crankshaft, threaded studs, and inside of the crankshaft rear seal/wear sleeve installation tool.

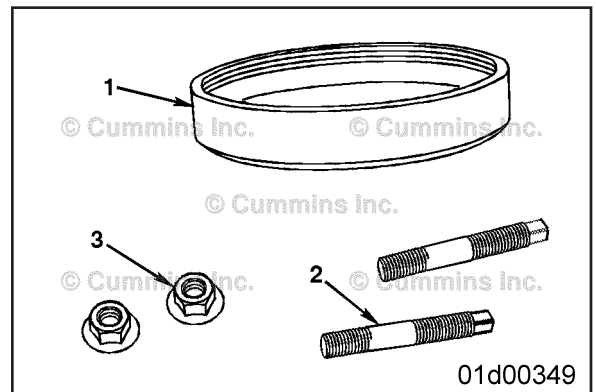

Position the chamfered end of the wear sleeve (A) onto the end of the crankshaft (B).

Position the counterbore end of installation tool (C) over threaded studs and align with wear sleeve, perpendicular to the end of the crankshaft.

Install the washers (D) and nuts (E) onto the threaded studs.

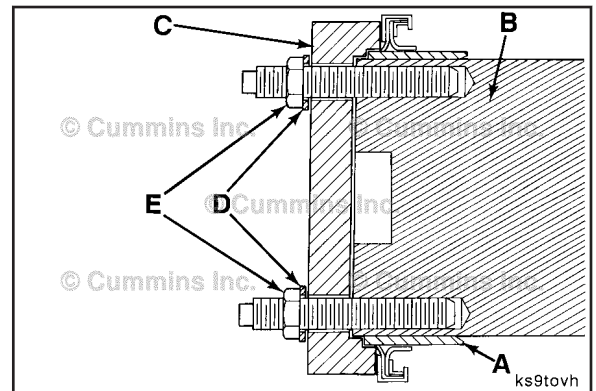

Alternately tighten the nuts $\frac{1}{2}$ of a turn until the installation tool contacts the end of the crankshaft.

Do **not** exceed $\frac{1}{2}$ of a turn of each nut to prevent wear sleeve binding and irregular stretch.

Torque Value: 20 N•m [15 ft-lb]

Remove the installation tool and threaded studs.

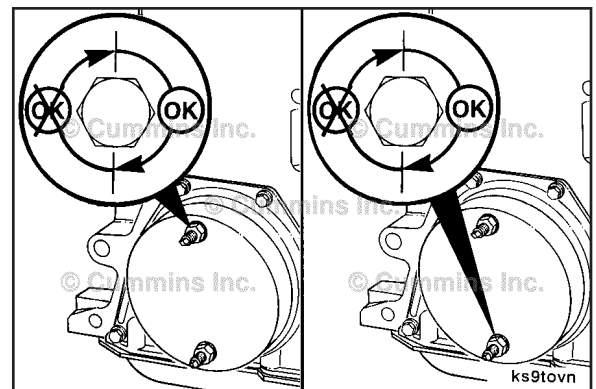

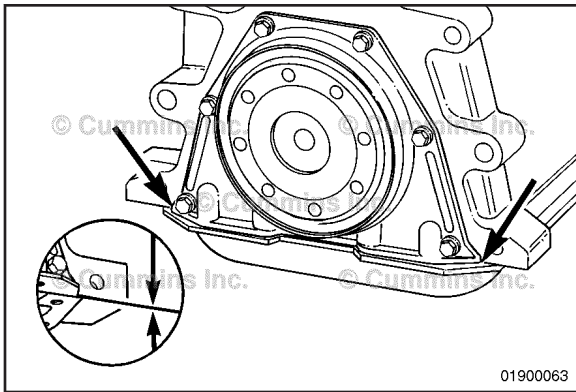

⚠ CAUTION ⚠

Do not push or force the cover in any direction. This may cause an irregular seal lip position after seal installation. An engine oil leak will result.

Align the rear cover even with both sides of the oil pan rail on the cylinder block.

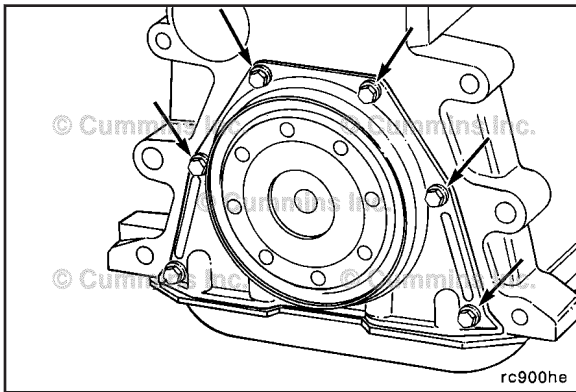

Tighten the rear cover capscrews.

Torque Value: 10 N•m [89 in-lb]

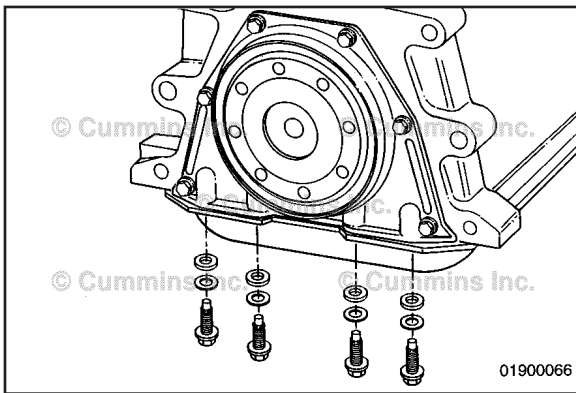

Install the four rear oil pan mounting capscrews into the pan.

Torque Value: 24 N•m [18 ft-lb]



Flywheel Housing (016-006)

Install

NOTE: Before installing the flywheel housing, make sure any locating dowel rings are in the same position as when the flywheel housing was removed.

NOTE: The sealant called for in the following step may appear different than what was originally used to build the engine.

Apply a 1.5 to 2.0 mm [0.06 to 0.08 in] wide bead of sealant, Part Number 3164070, to the back side of the flywheel housing in the path illustrated.

NOTE: Install the flywheel housing within 10 minutes of applying the sealant or it will **not** seal correctly. Once installed, allow the sealant to dry for 30 minutes before running the engine.

Install the flywheel housing and capscrews.

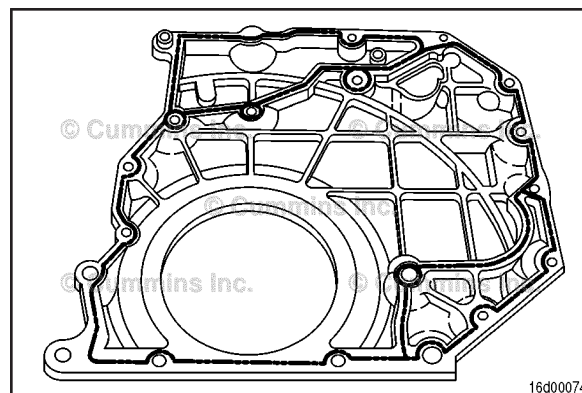

Tighten the flywheel housing capscrews in the sequence shown.

NOTE: Some engines are equipped with one additional capscrew **not** shown in the illustration. Tighten this capscrew last in the sequence.

Torque Value:

M10
 Step 1 49 N•m [36 ft-lb]

Torque Value:

M12
 Step 1 85 N•m [63 ft-lb]

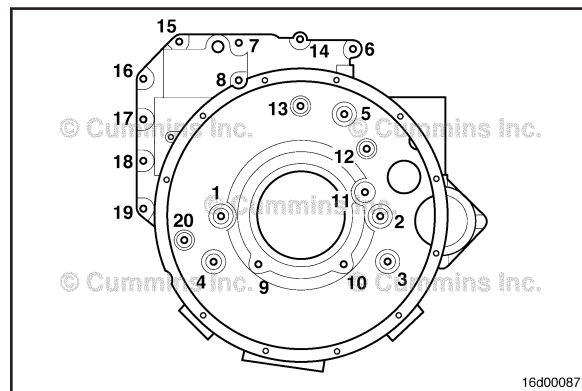

NOTE: Before installing the flywheel housing, make sure any locating dowel rings are in the same position as when the flywheel housing was removed.

If previously equipped, install a new rectangular seal on the rear seal carrier and apply assembly lube, Part Number 3163087.

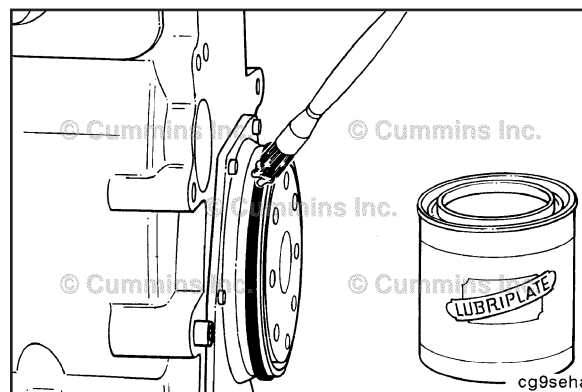

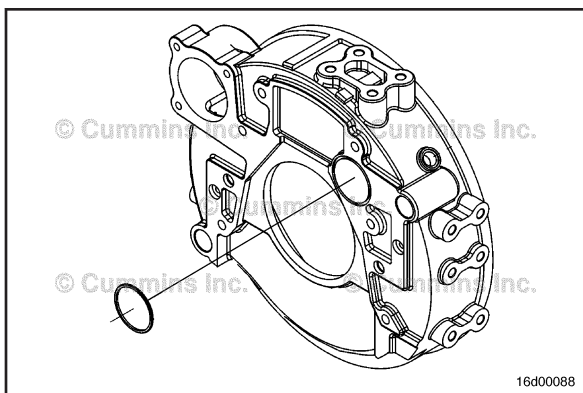

If previously equipped, install a new rectangular seal for the camshaft journal bore to the back side of the flywheel housing.

Apply a small amount of sealant, Part Number 3164067, to hold the seal in place until the flywheel housing is installed.

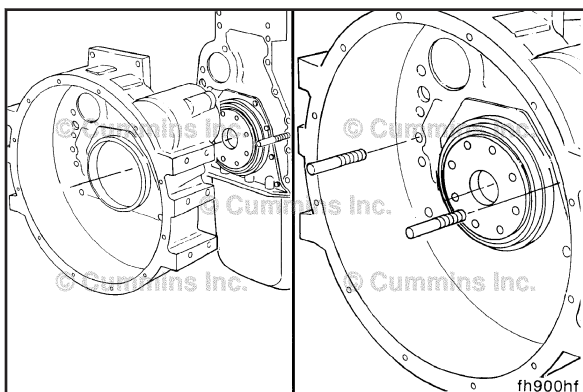

Inspect the rear face of the cylinder block and flywheel housing mounting surface for cleanliness and raised nicks or burrs.



Install two guide pins. Part Number 3163934.

Install the flywheel housing over the guide pins, making sure the flywheel housing is located on the dowel rings.

NOTE: Be sure the sealing ring is **not** damaged during installation.

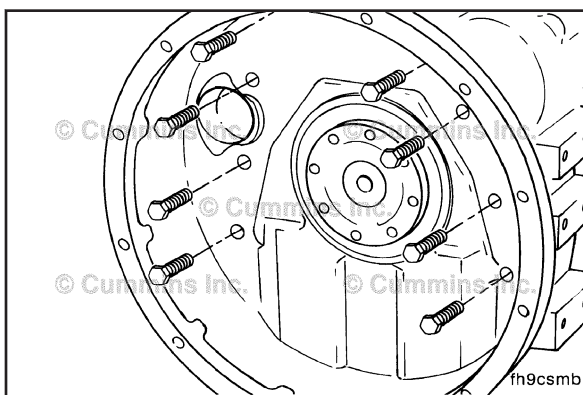

Remove the guide pins.

Install the mounting capscrews.

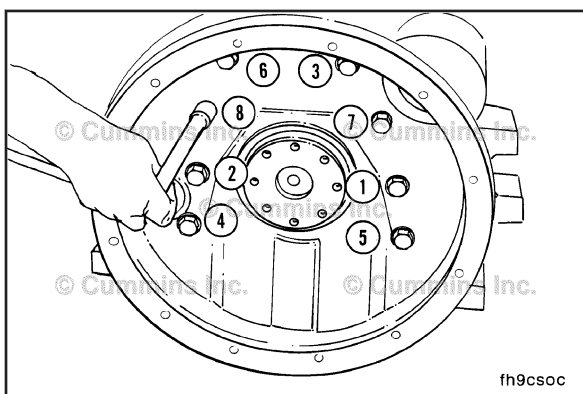

Tighten the flywheel housing capscrews in the sequence shown.

Torque Value: 77 N•m [57 ft-lb]



Crankcase Breather Tube (003-018)

Install

Breather Tube Mounting Plate Adapter

⚠CAUTION⚠

Do not apply an excess amount of sealant. Excess sealant may block the crankcase gases and cause excess crankcase pressure buildup. Engine oil leaks will result.

If sealant was previously used on the breather tube mounting plate adapter, apply a 2-mm [0.08-in] bead of sealant, Part Number 3164067 to the cover plate.

If o'ring(s) were previously used, lubricate the o'ring(s) with clean engine oil.

Install the breather tube mounting plate, o'rings (if equipped) and capscrews.

Torque Value: 24 N•m [18 ft-lb]

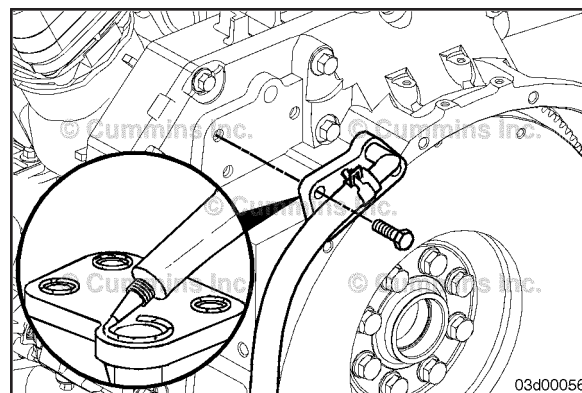

Clamp Plate Breather Tube Adapter

Lubricate the o'ring on the breather tube adapter with clean engine oil.

Install the breather tube adapter in the flywheel housing.

Install the capscrew and clamp plate to secure the breather tube adapter to the flywheel housing.

Torque Value: 24 N•m [18 ft-lb]

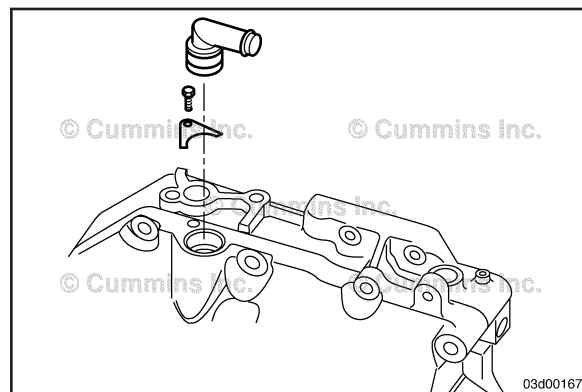

Breather Tube Adapter

Lubricate the o'ring on the breather tube adapter with clean engine oil.

Install the breather tube adapter into the flywheel housing.

Install the one capscrew and tighten.

Torque Value: 24 N•m [18 ft-lb]

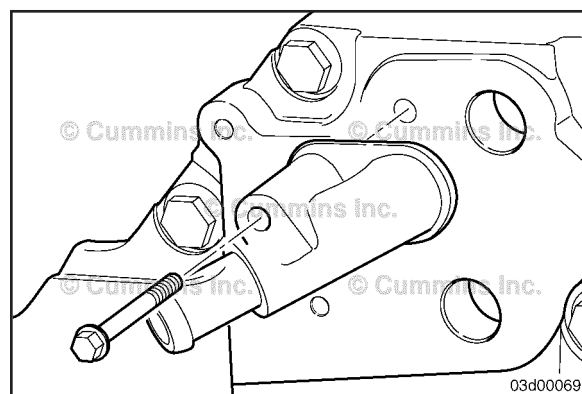

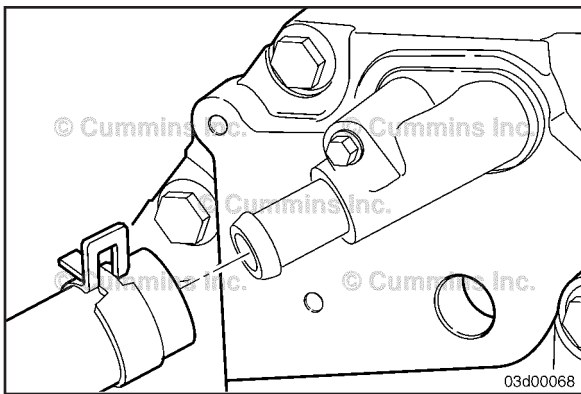

Connect/install the crankcase breather tube.

If equipped, secure the crankcase breather tube with a hose clamp.



If equipped, install any p-clips previously removed, in the recorded locations, to secure the crankcase breather tube.

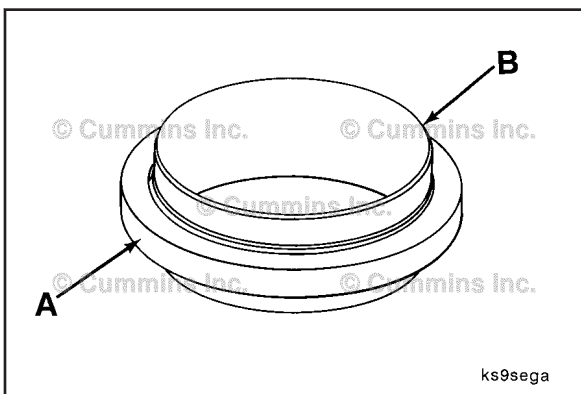

Crankshaft Seal, Rear (001-024)

Install

All Applications

⚠CAUTION⚠

Always replace the rear crankshaft seal with the same style seal as was previously installed to prevent oil leaks.

⚠CAUTION⚠

The seal lip/bore and the sealing surface on the crankshaft must be free from all oil residue to prevent seal leaks.

To aid in installation, apply a mild soap to the outside diameter of the seal case (A).

NOTE: On engines equipped with a lip style rear crankshaft seal, a seal pilot (B) is provided with the new seal. The seal **must** be left on the seal pilot while installing the seal onto the nose of the crankshaft. This will make sure the lips of the seal are **not** damaged during installation.

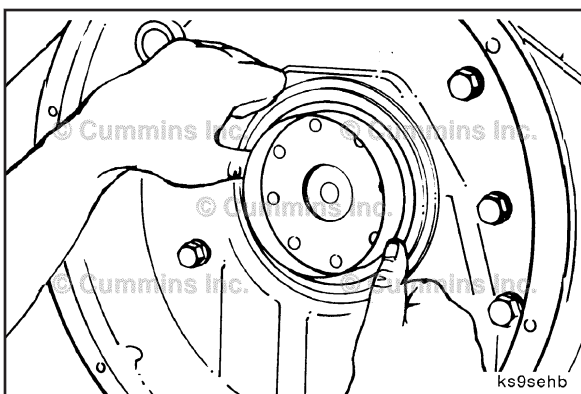

⚠CAUTION⚠

Always replace the rear crankshaft seal with the same style seal as was previously installed to prevent oil leaks.

Place the new rear crankshaft seal, with the seal pilot if required, over the crankshaft nose and slide it by hand toward the flywheel housing.

NOTE: Make certain the seal is positioned squarely with the crankshaft.

If used, remove the seal pilot.

Unitized Seal

Use service tool, Part Number 3164660, to finish installing the rear crankshaft seal.

With the rear crankshaft seal installed onto the crankshaft flange as described earlier in this procedure, mount the replacer screw assembly (1) onto the rear of the crankshaft.

Install the two M12 x 1.25 x 60-mm socket head capscrews (3).

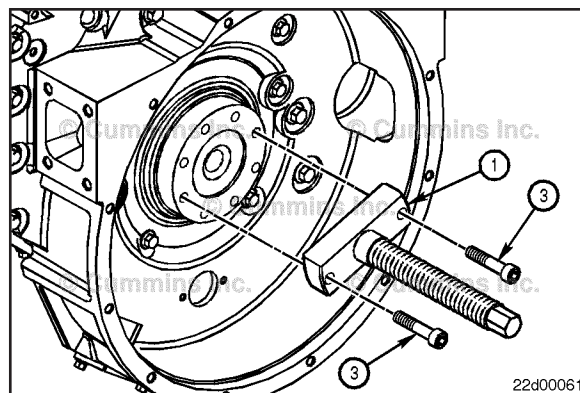

⚠ CAUTION ⚠

Do not use an impact wrench or air tools. Doing so can damage the tool.

While holding the replacer screw, install the crankshaft seal replacer (2) onto the replacer screw assembly.

Advance the crankshaft seal replacer toward the seal by rotating it **clockwise** until it is positioned against the seal.

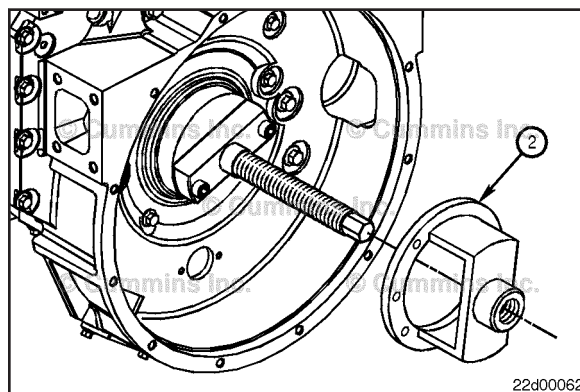

⚠ CAUTION ⚠

Do not overtighten the replacer screw assembly after the crankshaft seal replacer contacts the flywheel housing. Doing so can damage the tool.

While holding the crankshaft seal replacer, rotate the replacer screw **counterclockwise** until the crankshaft seal replacer is positioned against the flywheel housing.

Remove the service tools.

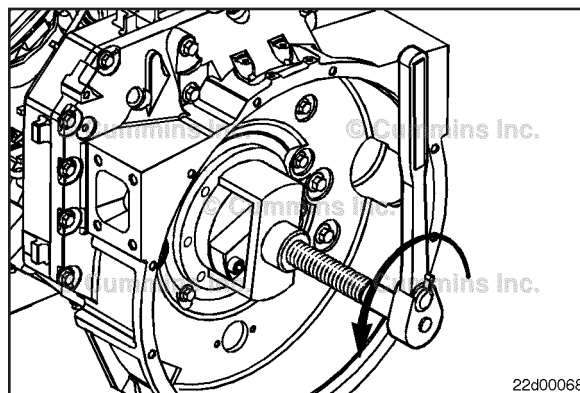

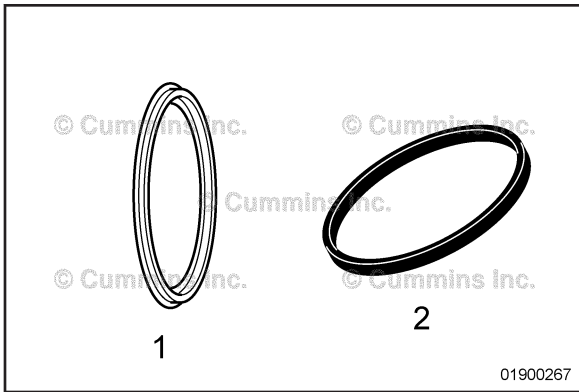

Lip Seal

Each new lip style crankshaft seal comes with a disposable seal.



- The seal driver (1) for front gear train engines, which is typically a metal ring, will install the crankshaft seal to the proper depth in the rear seal carrier bore.
- The seal driver (2) for rear gear train engines, which is typically a plastic ring, will install the crankshaft seal to the proper depth in the flywheel housing bore.

NOTE: For rear gear train engines, rear crankshaft seals for the wet flywheel housing applications do **not** come with a disposable seal driver. Service tool, Part Number 3824078, **must** be used to install the rear crankshaft seal for the wet flywheel housing. This is the same service tool used for installing the rear crankshaft seal and wear sleeve assembly. Refer to Procedure 001-067. For front gear train engines, this service tool can be used in place of the disposable seal driver that comes with the crankshaft seal.

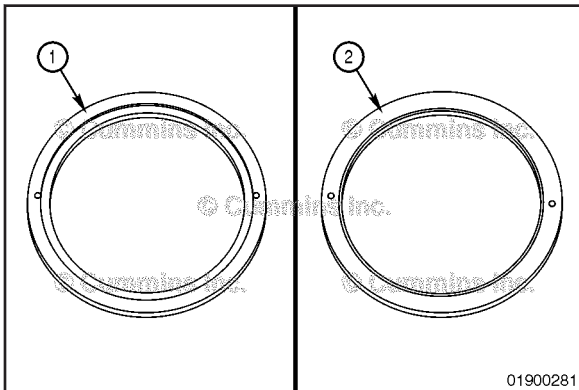

For rear gear train engines, the disposable plastic driver that comes with the new rear crankshaft seal is designed to be used with two types of seals.

- A double outer dust lip rear crankshaft seal - for this type of seal, the side of the disposable driver (1) with the large chamfer on the inner diameter **must** be used to contact the seal.
- A single outer dust lip rear crankshaft seal - for this type of seal, the side of the disposable driver (2) with the small chamfer on the inner diameter **must** be used to contact the rear crankshaft seal.

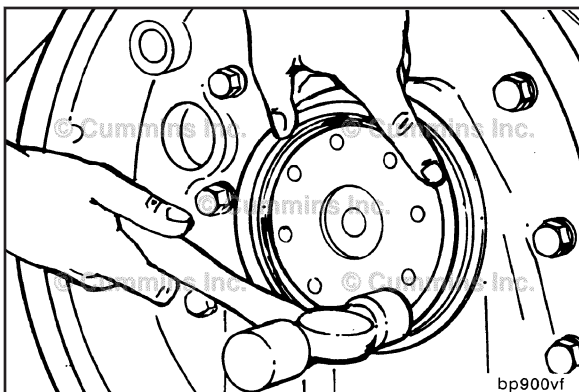

NOTE: It can be necessary to lightly tap the rear crankshaft seal with a plastic hammer, without the disposable seal driver, to help start the rear crankshaft seal in the flywheel housing bore.

With the rear crankshaft seal installed onto the crankshaft flange as described earlier in this procedure. Use the appropriate disposable seal driver that comes with each new rear crankshaft seal to install the crankshaft seal to the correct depth in the housing.

Use a plastic hammer to drive the crankshaft seal into the housing until the alignment tool stops against the housing. Hit the tool at 12, 3, 6 and 9 o'clock positions to drive the crankshaft seal evenly and to prevent bending the seal carrier.

Optional Method

For rear gear train engines, the disposable plastic driver that comes with the new rear crankshaft seal has been designed with two holes in the outer ring. These holes are provided so that the driver can be used in conjunction with the Rear Crankshaft Seal Replacer Kit, Part Number 3164660.

Table 2. Rear Crankshaft Seal Replacer Kit, Part Number 3164660			
Item Number	Part Number	Description	Quantity
1	3164666	Replace screw assembly	1
2	3164664	Crankshaft seal replacer	1
3	3164174	Socket head capscrew, M12 x 1.25 x 25 mm	2
4	3164217	Sheet metal screw, Number 10 x 25.4 mm [1 in] long	25 (7 shown)
Not shown	3164218	Drill. 3.57 mm [9/64 in]	1
5	—	Disposable plastic driver (purchased with rear crankshaft seal kit)	1

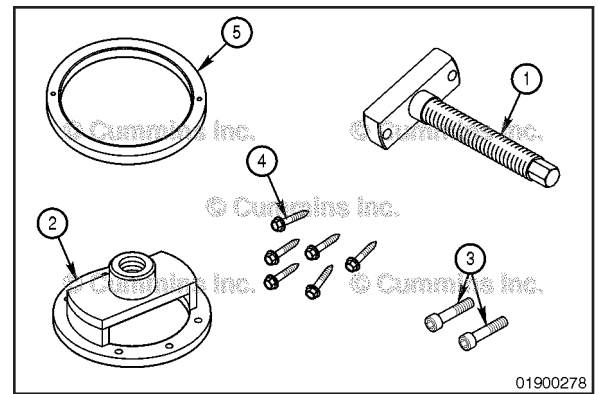

⚠ CAUTION ⚠

Do not use the sheet metal screws that come with the Rear Crankshaft Seal Replacer Kit, service tool part number 3164660. The sheet metal screws are too long. When selecting the correct sheet metal screw, make sure the tip of the sheet metal screw does not protrude past the face of the driver. Damage to the crankshaft seal will result.

With the correct side of the disposable driver facing outwards for the type of seal that will be installed, center the disposable driver on the crankshaft seal replacer.

Attach the disposable driver to the crankshaft seal replacer using a number 2 sheet metal screw (number 10 by 19 mm [.75 in] long).

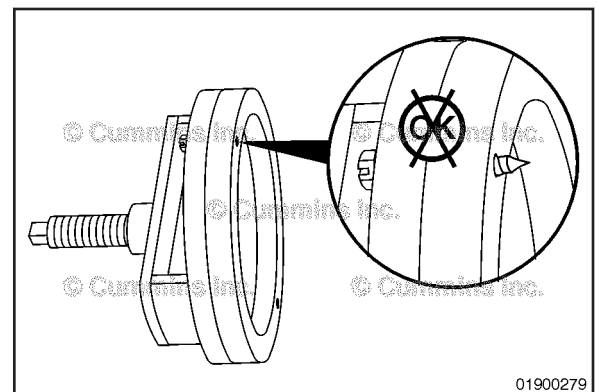

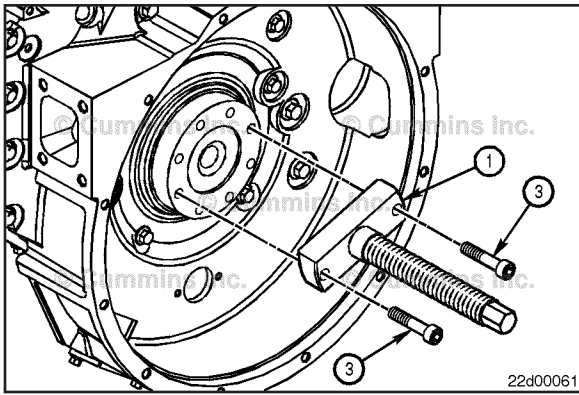

With the rear crankshaft seal installed onto the crankshaft flange as described earlier in this procedure, mount the replacer screw assembly (1) onto the rear of the crankshaft.

Install the two M12 x 1.25 x 60-mm socket head capscrews (3).

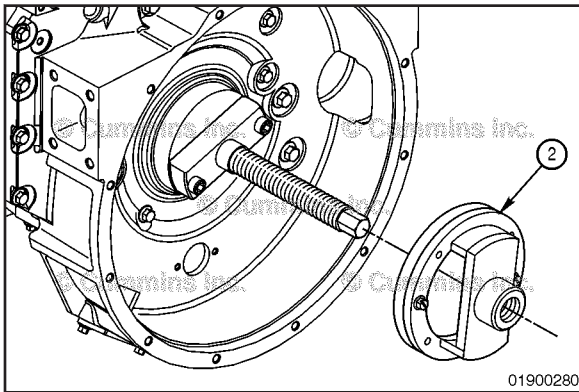

CAUTION

Do not use an impact wrench or air tools. Doing so can damage the tool.

Lubricate the replacer screw with anti-seize compound or a suitable grease.

Hold the replacer screw and install the crankshaft seal replacer (2) onto the replacer screw assembly. Advance the crankshaft seal replacer toward the seal by rotating it **clockwise** until the attached disposable driver is positioned against the rear crankshaft seal.

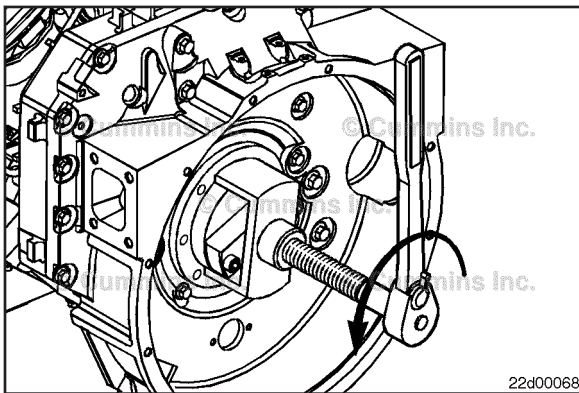

CAUTION

Do not overtighten the replacer screw assembly after the crankshaft seal replacer contacts the flywheel housing. Doing so can damage the tool.

While holding the crankshaft seal replacer, rotate the replacer screw counterclockwise until the disposable driver attached to the crankshaft seal replacer makes contact with the flywheel housing.

Remove the service tools.

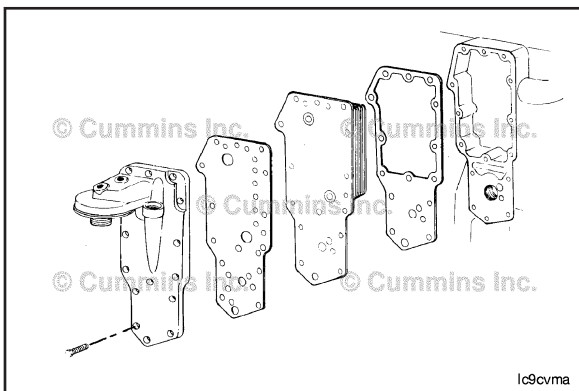

Lubricating Oil Cooler (007-003)

Install

NOTE: Be sure to remove the shipping plugs from the oil cooler element.

NOTE: When installing a new lubricating oil cooler be sure to use the correct part number. Replace with the same part number or use the engine serial number and QuickServe OnLine to ensure the use of the correct part.

Assemble the lubricating oil cooler cover, capscrews, gaskets, and oil cooler.

If the engine uses a lubricating oil cooler cover in which the lubricating oil filter is mounted low, use the torque sequence shown.



NOTE: Snug capscrew numbers six and eight, then tighten in the sequence shown.

Torque Value: 24 N•m [212 in-lb]

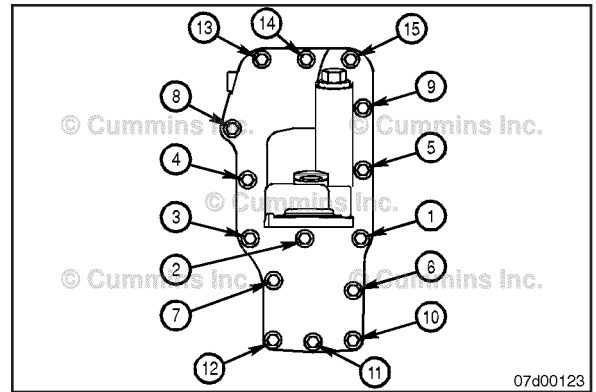

If the engine uses a lubricating oil cooler cover in which the lubricating oil filter is mounted high, use the torque sequence shown.



Torque Value: 24 N•m [212 in-lb]

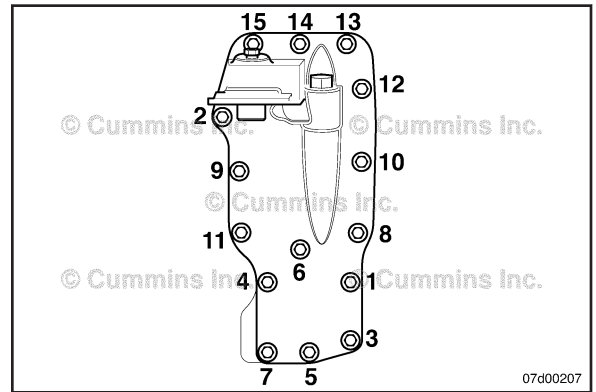

Lubricating Oil Filter (Spin-On) (007-013)



Install

⚠CAUTION⚠

The lack of lubrication during the delay until the filter is pumped full of oil at start-up can damage the engine.

Use clean 15W-40 oil to coat the gasket surface of the filter.

Fill the filter with clean 15W-40 oil.

NOTE: Be careful that no debris is poured into the filter. If using an oil supply with a metallic or plastic seal under the cap, be careful to peel the seal back. Puncturing the seal with a knife or sharp object can create debris in the oil container.

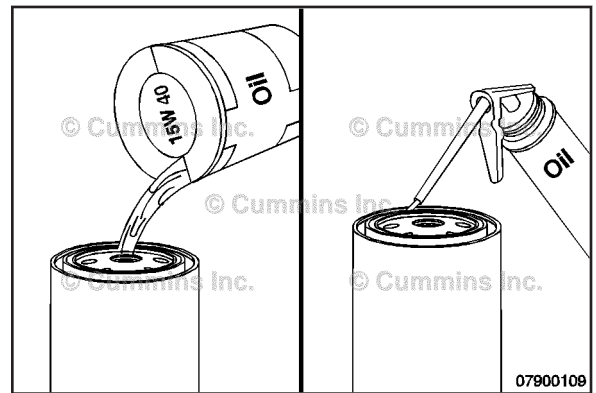

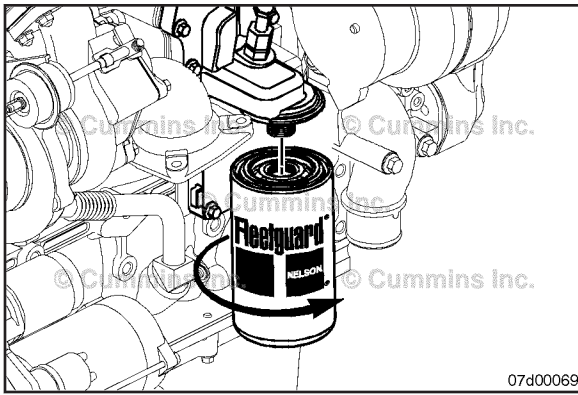

CAUTION

Mechanical overtightening of the filter can distort the threads or damage the filter element seal.



Install the filter on the oil filter head. Tighten the filter until the gasket contacts the filter head surface.



Tighten 3/4 turn to 1 turn after gasket makes contact with the filter head.

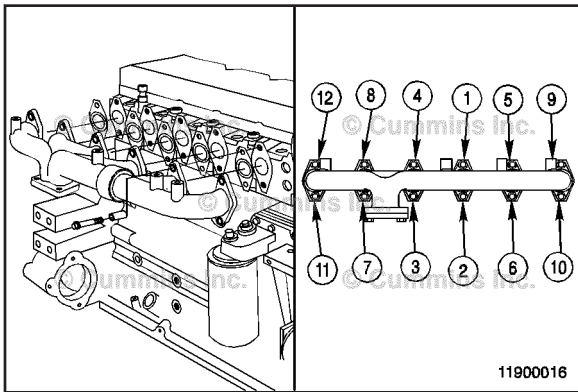

Exhaust Manifold, Dry (011-007)

Install



Apply high-temperature anti-seize compound to the exhaust manifold capscrew threads.

Install the exhaust manifold, new gaskets, spacers, and lockplates.

Follow the tightening sequence shown in the illustration.

NOTE: To aid in alignment of the exhaust manifold, two capscrew passages have a smaller diameter than other passages. The location of these varies with manifold configuration. The capscrews in the smaller passages should be tightened first, with the remaining capscrews tightened in a sequence like the pattern shown in the illustration.

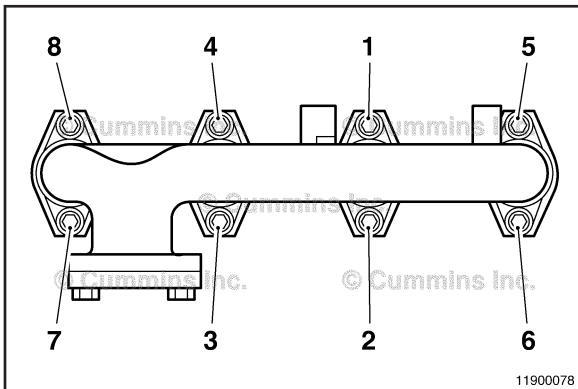

For QSB6.7 CM850 engines:

Tighten the exhaust manifold mounting capscrews.

Torque Value: 53 N•m [39 ft-lb]

For all other engines:

Tighten the exhaust manifold mounting capscrews.

Torque Value: 43 N•m [32 ft-lb]

Turbocharger (010-033)

Install

Automotive and Industrial

⚠ WARNING ⚠

This component or assembly weighs greater than 23 kg [50 lb]. To prevent serious personal injury, be sure to have assistance or use appropriate lifting equipment to lift this component or assembly.

- Apply a film of high-temperature anti-seize compound to the turbocharger mounting studs.

⚠ CAUTION ⚠

The new gasket must match the one that was removed. Use of the incorrect gasket will result in turbocharger damage. Never reuse a turbocharger mounting gasket.

- Use a new gasket and install the turbocharger.
- Install and tighten the four mounting nuts.

NOTE: The torque values given have been established using anti-seize compound as a lubricant.

Torque Value: 43 N•m [32 ft-lb]

- Install the turbocharger compressor outlet elbow, v-band clamp, and a new o-ring seal on the turbocharger compressor discharge outlet, if applicable.
- Tighten the clamp.

Torque Value: 8 N•m [71 in-lb]

- Rotate the compressor housing to fit the intake pipes, if necessary.

NOTE: Use the snap ring or loosen the v-band clamp to make necessary adjustments. Make sure the snap ring is seated and/or the v-band clamp is tight when finished with adjustment.

- Install the inlet pipe and air inlet connection and tighten the clamp.

Torque Value: 8 N•m [71 in-lb]

- Install the exhaust pipe and tighten the clamp.

Torque Value: 8 N•m [71 in-lb]

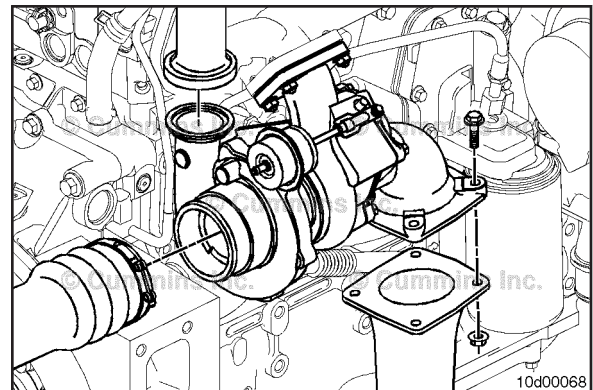
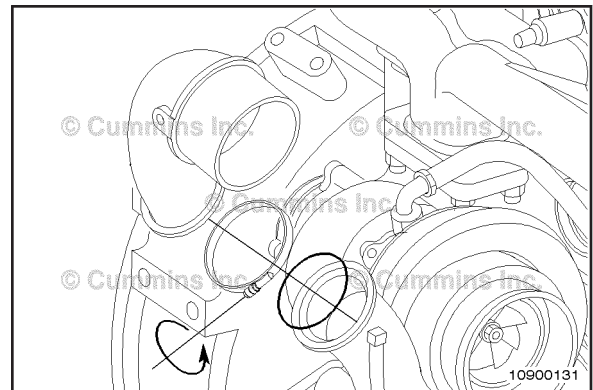
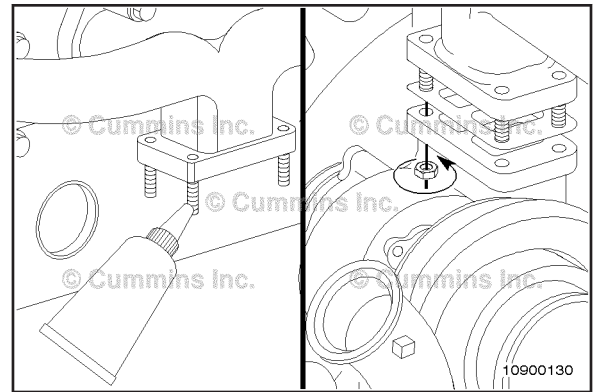

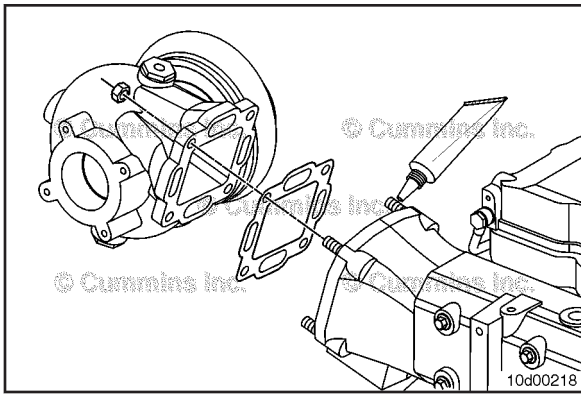

Marine Applications

▲WARNING▲

This component or assembly weighs greater than 23 kg [50 lb]. To prevent serious personal injury, be sure to have assistance or use appropriate lifting equipment to lift this component or assembly.



▲CAUTION▲

The gasket water ports are larger on the top and bottom passages. The gasket is also marked “Turbocharger” on the side facing the turbocharger. The gasket must be installed with the port size matching the port size of the exhaust manifold and turbocharger, and with the “Turbocharger” marking facing the turbocharger to prevent damage to the turbocharger from overheating.

- Apply a film of high-temperature anti-seize compound to the turbocharger mounting studs.
- Use a new gasket and install the turbocharger.
- Install and tighten the four mounting nuts.

NOTE: The torque values given have been established using anti-seize compound as a lubricant.

Torque Value: 43 N•m [32 ft-lb]

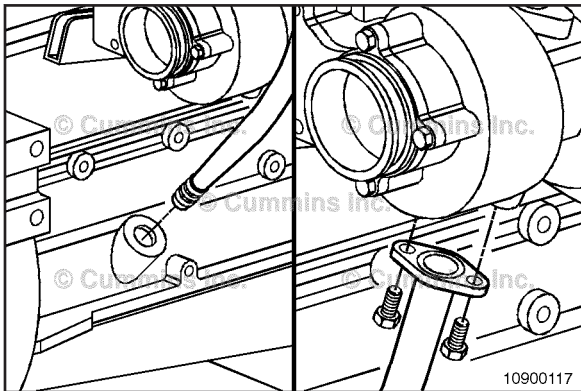

Turbocharger Oil Drain Line (010-045) Install



Apply a thin film of oil to the drain line o-rings.

Push the drain line into the drain line boss. Be sure both o-rings are completely seated in the bore.



Install the drain line capscrews with a new gasket.

Torque Value: 23 N•m [204 in-lb]



Operate the engine and check for leaks.

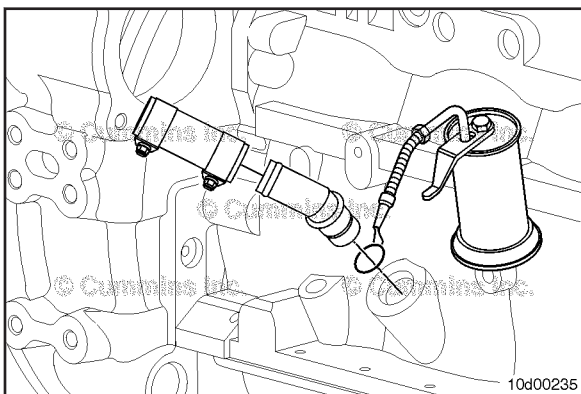

Install a new o-ring on the turbocharger oil drain line connection (cylinder block end), if applicable. Apply a light film of lubricating oil to the o-ring.

Push the connection into the cylinder block until the o-ring is completely seated.

Install the hose connection over the end of the drain line connection.

Install two hose clamps over the oil drain hose.

Install the drain line into the drain line hose connection at the cylinder block.

Install the drain line and a new gasket to the bottom of the turbocharger.

Tighten the capscrews at the bottom of the turbocharger.

Torque Value: 23 N•m [204 in-lb]

Tighten the hose clamps.

Torque Value: 8 N•m [71 in-lb]

Operate the engine and check for leaks.

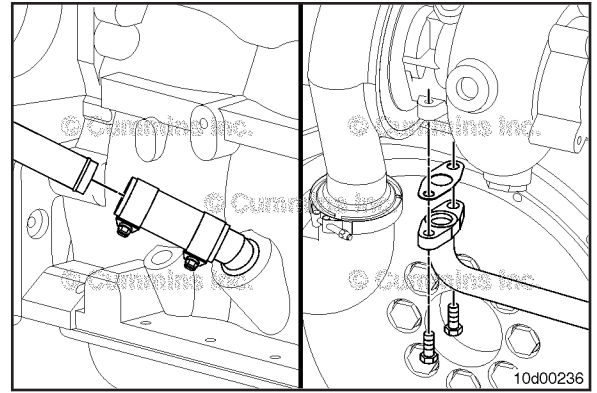

Turbocharger Oil Supply Line (010-046)

Install

⚠CAUTION⚠

Maintain a minimum distance of 10 mm [0.39 in] between the oil supply line and the turbine housing or exhaust manifold, and 5 mm [0.20 in] between the oil supply line and other components to prevent oil line high temperature damage and chafing.

Fill the turbocharger oil inlet with clean oil.

Install the oil supply line at both the filter head and the turbocharger bearing housing. Use new copper seal washers or o-ring seals.

Tighten the oil supply line to final torque.

Torque Value: 28 N•m [21 ft-lb]

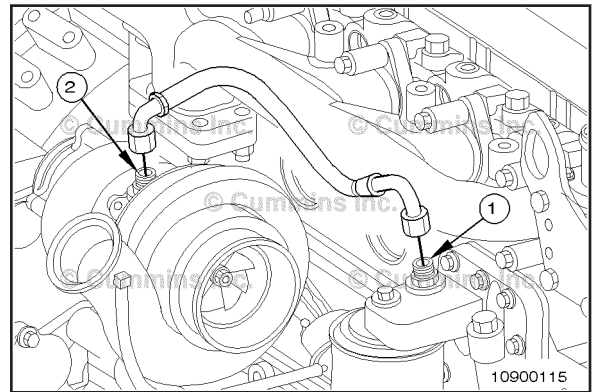

Flywheel (016-005)

Install

Install two M12 x 1.25 x 90-mm guide pins into the crankshaft flange 180 degrees apart.

NOTE: If a clutch is used in the equipment, the threads in the clutch pressure plate mounting capscrew holes can be metric or standard. Be **sure** to use the correct capscrews.

Determine the capscrew thread design and size, and install two T-handles into the flywheel (at points 1 and 2).

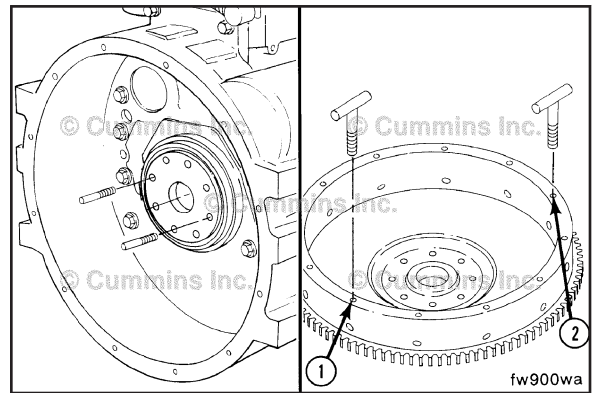

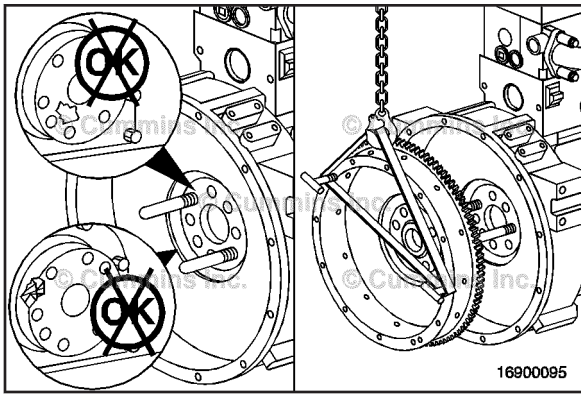

WARNING

The component weighs 23 kg [50 lb] or more. To reduce the possibility of personal injury, use a hoist or get assistance to lift the component.



Inspect the rear face of crankshaft and flywheel mounting flange for cleanliness and raised nicks or burrs.



Install the flywheel on the guide pins.

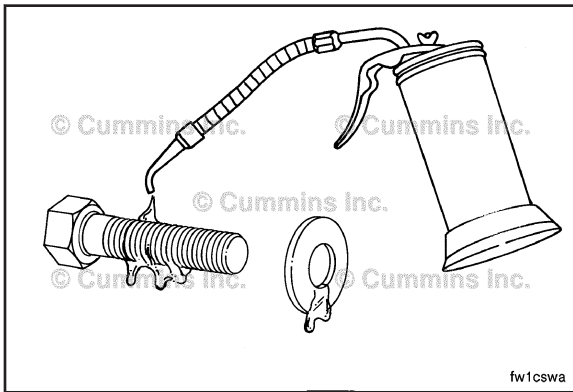

Lubricate the threads of the capscrews and the surface of the washers with clean lubricating engine oil.

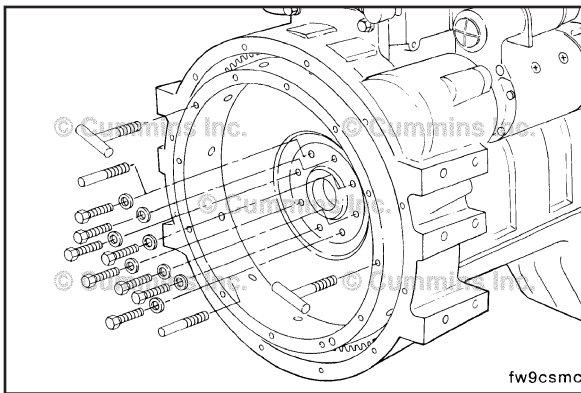

Install the six capscrews.

Remove the T-handles and guide pins.



Install the remaining capscrews into the holes from which the guide pins were removed.

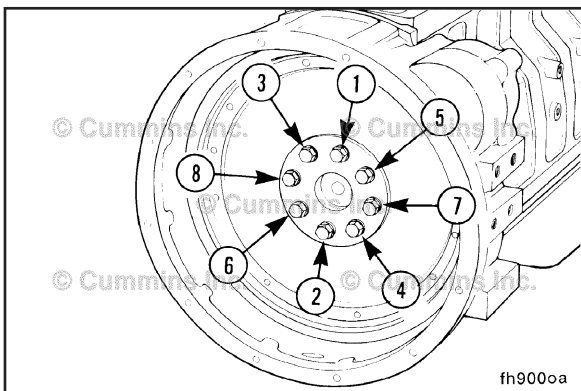

NOTE: Use the barring tool, Part Number 3824591, to hold the flywheel to prevent rotation.

Tighten the capscrews in a star pattern.



Torque Value:

Step 1 30 N•m [22 ft-lb]
Step 2 Plus 60-degree turn



Flexplate (016-004)

Install

NOTE: Some flexplates require mounting plates and/or clamp rings. It will be necessary to install any mounting plates and/or clamp rings prior to or with the flexplate as noted during removal.

Install the flexplate capscrews and flexplate, and tighten the capscrews.

Torque Value:

Flexplate Capscrews		
Step 1	30 N•m	[22 ft-lb]
Step 2	Plus 60-degree turn	

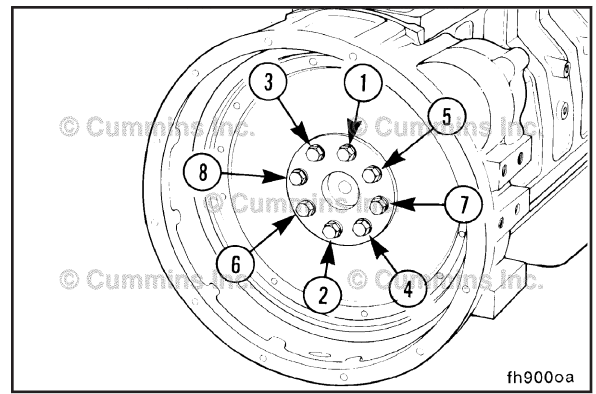

Install the flexplate and flexplate mounting capscrews.

Tighten the capscrews.

Torque Value: 44 N•m [32 ft-lb]

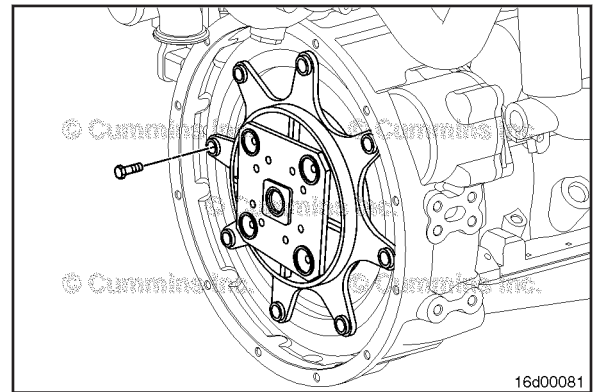

If the engine is equipped with a flex-coupling guard plate, install the flex-coupling guard plate onto the flywheel housing. Position the wiring harness connector at the 11 o'clock position, as shown in the illustration. Install a cap screw to hold it in place.

Install the remaining eight capscrews.

Tighten the capscrews.

Torque Value: 36 N•m [27 ft-lb]

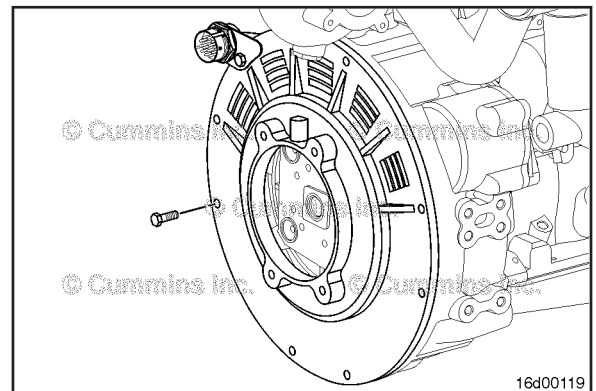

Starting Motor (013-020)

Install

For engines with wet flywheel housings, apply a 1.5 to 2.0 mm [0.06 to 0.09 in] wide bead of sealant, Part Number 3164067, to the flywheel housing starting motor mounting flange.

NOTE: If a starting motor spacer is required, make sure to apply sealant to the side of the spacer that contacts the starting motor.

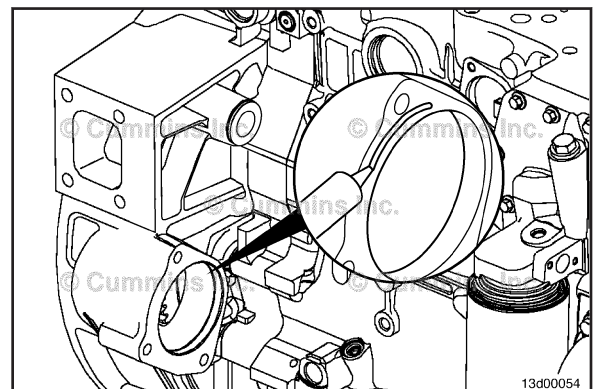

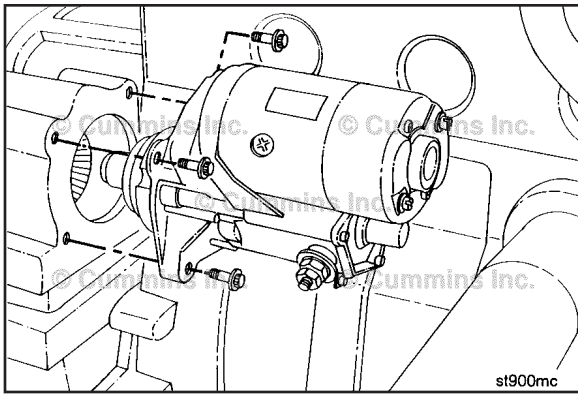

Install the three capscrews, the starting motor, and starting motor spacer, if required.

Torque Value: 43 N•m [32 ft-lb]

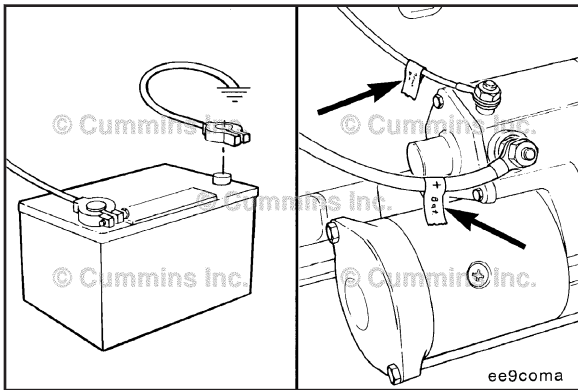

Cummins® Branded Starters

⚠ CAUTION ⚠

Do not overtighten the electrical connections. Starter damage can result.

NOTE: Use the location tags to help identify where each wire connection goes.

Connect the electrical connections to the starter motor.

Torque Value:

M5

Step 1 4 N•m [35 in-lb]

Torque Value:

M10

Step 1 21 N•m [185 in-lb]

Install the Jump Start Protection (JSP) cover and cover nut on the M-terminal post.

NOTE: The JSP cover nut is the third nut on the M-terminal, M5 terminal size. Failure to observe the proper torque specification can result in loss of conductivity to the M lead and result in a no crank condition for the starter and the engine.

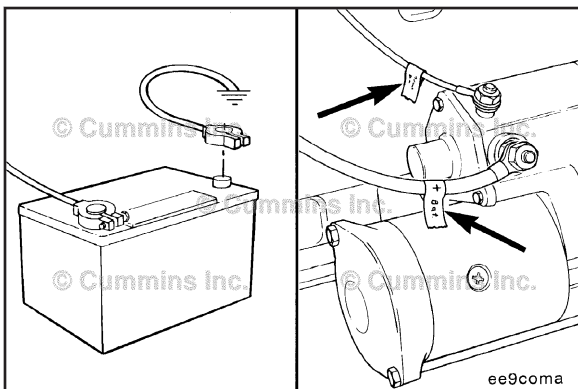

Non-Cummins® Branded Starters

⚠ CAUTION ⚠

Do not overtighten the electrical connections. Starter damage can result.

NOTE: Use the location tags to help identify where each wire connection goes.

Install the starter motor electrical connections.

For Non-Cummins® branded starters, refer to the OEM service manual for torque specifications.

Coolant Thermostat Housing Support (008-015)

General Information

This procedure applies to QSB5.9 marine keel cooled engines **only**

Install

Install the thermostat housing bracket and mounting capscrews.

Tighten the capscrews.

Torque Value: 44 N•m [32 ft-lb]

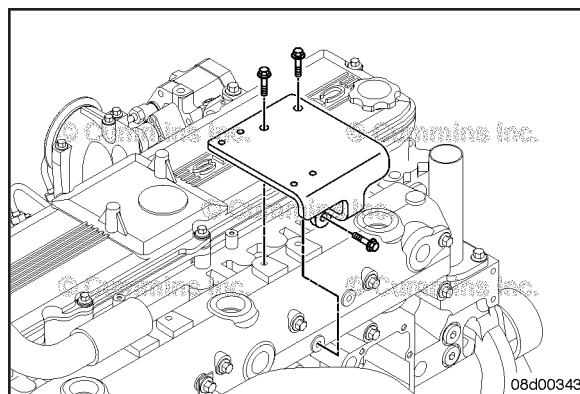

Coolant Thermostat Housing (008-014) General Information

This procedure applies to QSB5.9 keel cooled engines **only**

Install

Place the vibration isolators on top of the thermostat housing support bracket.

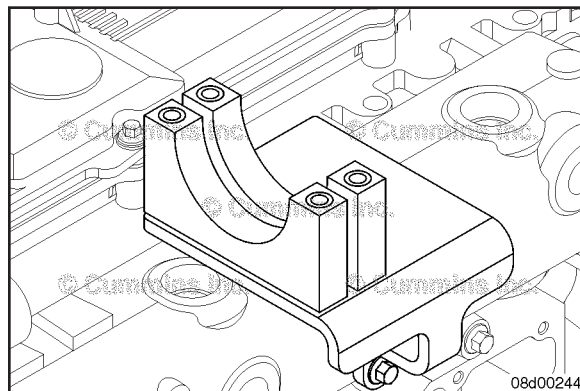

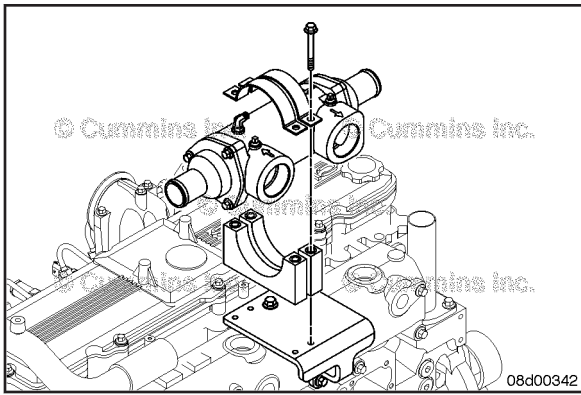

Install the thermostat housing onto the isolators using clamps and capscrews as shown.

Tighten the capscrews.



Torque Value: 44 N•m [32 ft-lb]

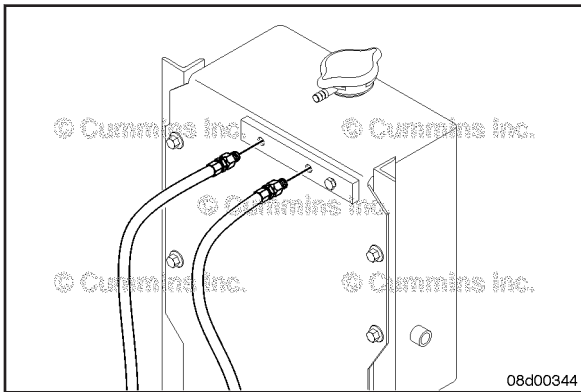

Coolant Vent Lines (008-017) Install

Connect the coolant vent line at the top of the expansion tank and the top of the exhaust manifold.

Connect the coolant vent line for the turbocharger at the top of the expansion tank.

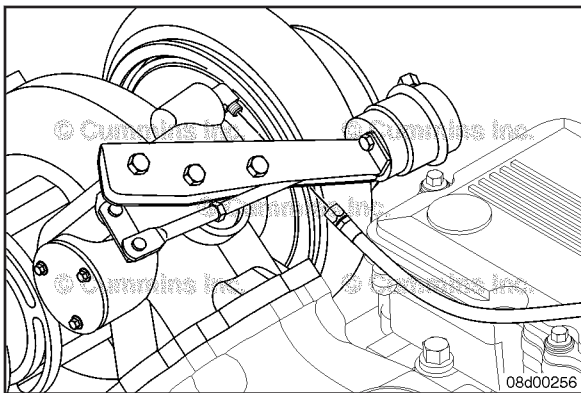

Connect the coolant vent line to the top of the turbocharger.

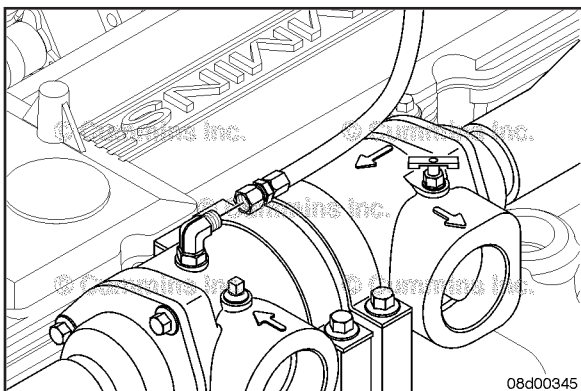

Connect the coolant vent line from the top of the expansion tank and to the top of the thermostat housing.

Alternator Bracket (013-003)

Install

Spool Mount

NOTE: On some applications, the alternator bracket and water inlet are combined in the same bracket. Refer to Procedure 008-082, where applicable.

Install the upper alternator bracket and mounting capscrews.

Install the lower alternator bracket and mounting capscrew.

Tighten the upper and lower alternator bracket mounting capscrew.

Torque Value:

M8	24 N•m	[18 ft-lb]
M10	43 N•m	[32 ft-lb]

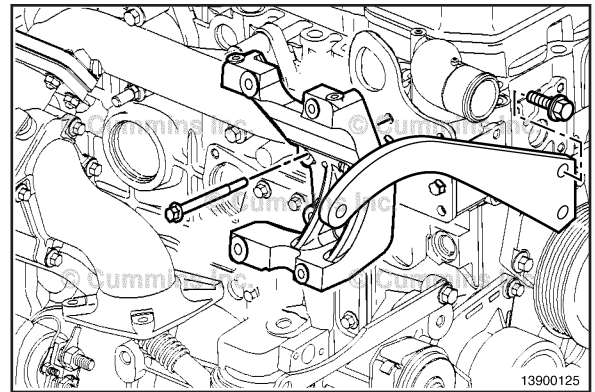

Hinge Mount.

Install the upper alternator bracket and mounting capscrews.

Install the lower alternator bracket and mounting capscrew.

Tighten the upper and lower alternator bracket mounting capscrew.

Torque Value:

M8	24 N•m	[18 ft-lb]
M10	43 N•m	[32 ft-lb]

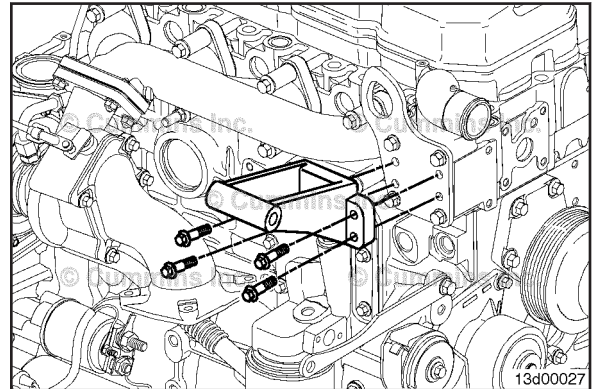

Pad Mount

⚠CAUTION⚠

If the alternator bracket has alignment roll pins, assure the pins are contacting the surface on cylinder head when the bracket is installed. Failure to do so will cause misalignment of the alternator pulley.

Install the alternator bracket.

Install and tighten the alternator bracket mounting capscrew.

Torque Value: 45 N•m [33 ft-lb]

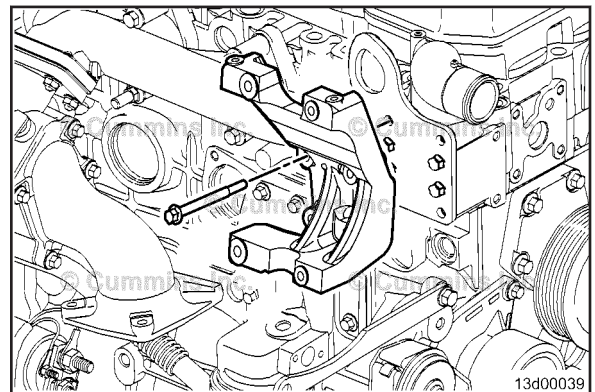

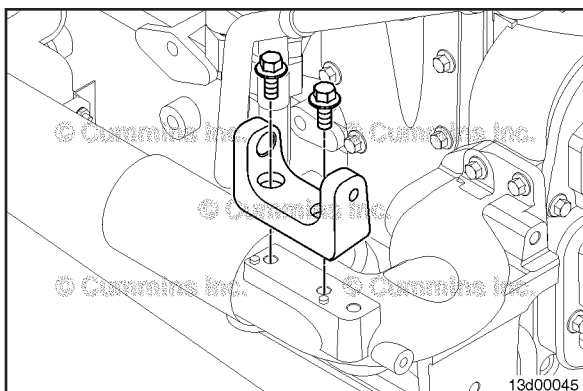

Marine Applications



NOTE: The coolant connection tube has two dowel pins used for correctly locating the alternator mounting bracket during installation.

Install the alternator mounting bracket over the two dowel pins.

Install the two alternator bracket mounting capscrews and tighten.

Torque Value: 54 N•m [40 ft-lb]

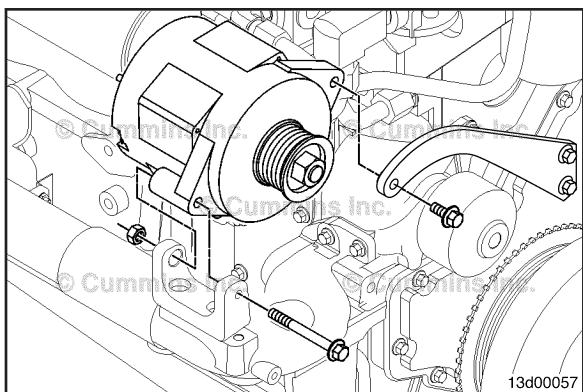

Alternator (013-001)

Install



Spool Mount

Install the alternator and the bottom alternator mounting cap screw and nut.

Install the upper alternator link mounting cap screw at the top of the alternator.

Tighten the cap screws.

Torque Value:

Lower Mounting Cap screw		
Step 1	40 N•m	[30 ft-lb]

Torque Value:

Upper Link Mounting Cap screw		
Step 1	24 N•m	[212 in-lb]

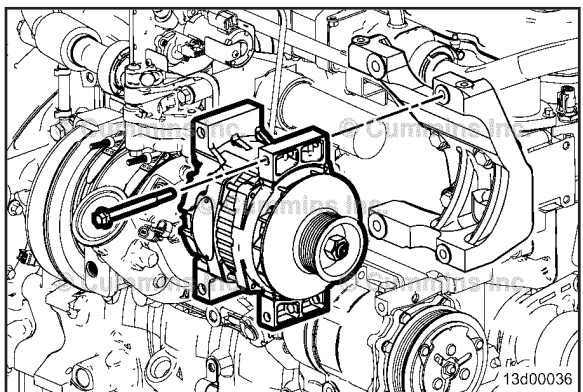

Pad Mount

Install the alternator.

Install and tighten the alternator mounting cap screws.



Torque Value:

M10 Cap screw		
Step 1	36 N•m	[27 ft-lb]

Torque Value:

M12 Cap screw		
Step 1	64 N•m	[47 ft-lb]

Hinge Mount

Install the alternator.

Install and tighten the alternator mounting capscrew.

Torque Value: 40 N•m [30 ft-lb]

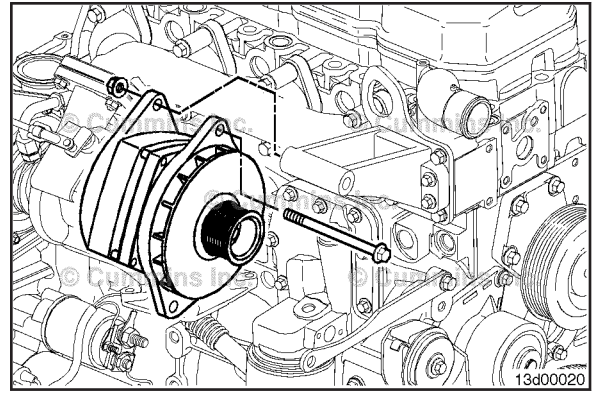

Install the alternator link capscrew.

Torque Value: 24 N•m [212 in-lb]

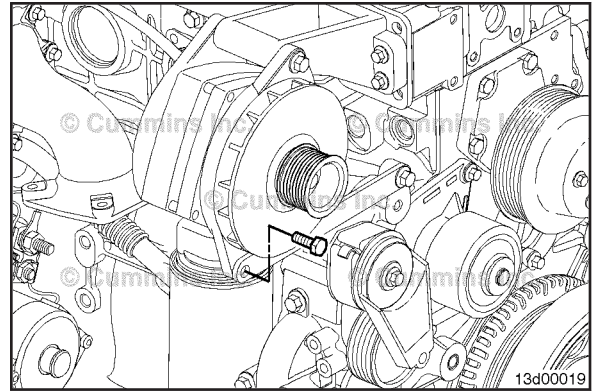

Marine Applications

Spool Mount or Saddle Mount

Inspect the water inlet connection. Test fit the alternator link to the water inlet. If the machined area is **not** sufficient for the link to sit flat as installed, the inlet will need to be replaced.

Refer to Procedure 008-082 in Section 8.

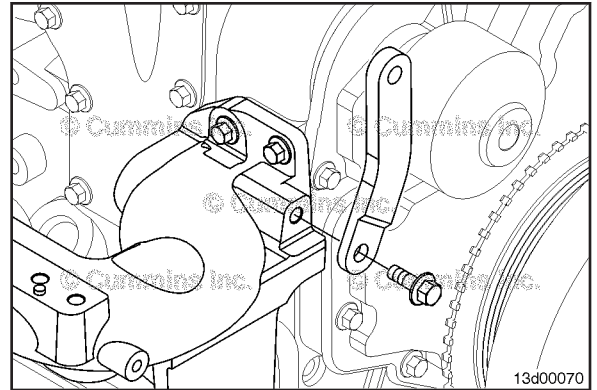

Install the alternator and alternator mounting capscrew.

Install the alternator link. Coat the lower capscrew threads (1) with a light coat of Loctite® 242, or equivalent, thread locking compound.

Install the capscrews.

Tighten the capscrews.

Torque Value:

Capscrews (1,3)

Step 1 44 N•m [33 ft-lb]

Torque Value:

Capscrew (2)

Step 1 35 N•m [26 ft-lb]

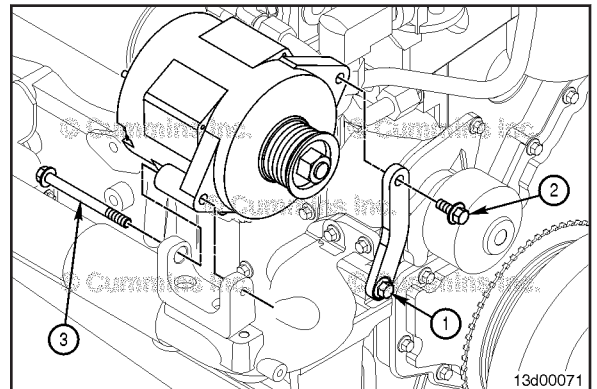

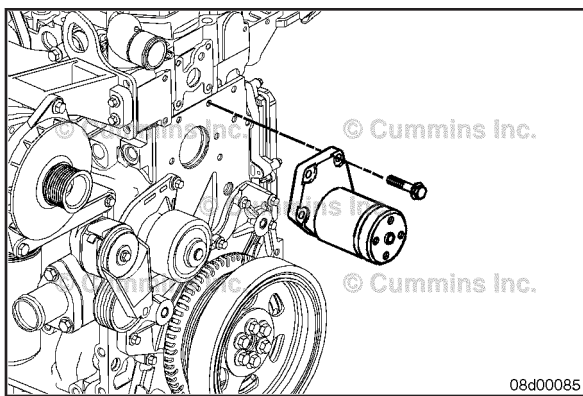

Fan Hub, Belt Driven (008-036)

Install



Install the fan hub.

Torque Value: 33 N•m [24 ft-lb]

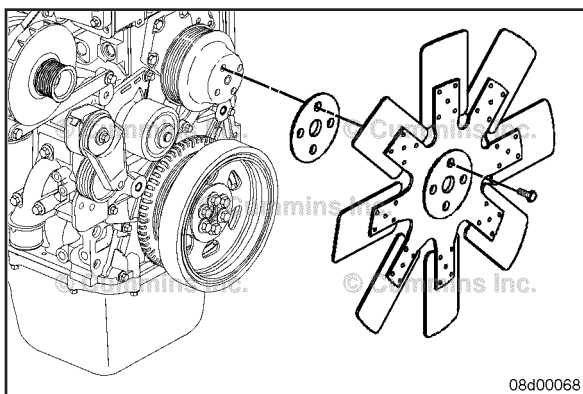

Fan Spacer and Pulley (008-039)

Install



Install the fan pulley.

Install the cooling fan and drive belt. Refer to Procedure 008-002 (Drive Belt, Cooling Fan) in Section 8.

Install the spacer, fan, and fan capscrews.

Torque Value:

M6

Step 1 10 N•m [89 in-lb]

Torque Value:

M10

Step 1 43 N•m [32 ft-lb]

Torque Value:

M12

Step 1 77 N•m [57 ft-lb]

NOTE: Use the tension of the drive belt to hold the cooling fan in place when tightening the mounting capscrews. Do **not** hold the fan blades to keep the cooling fan from rotating.

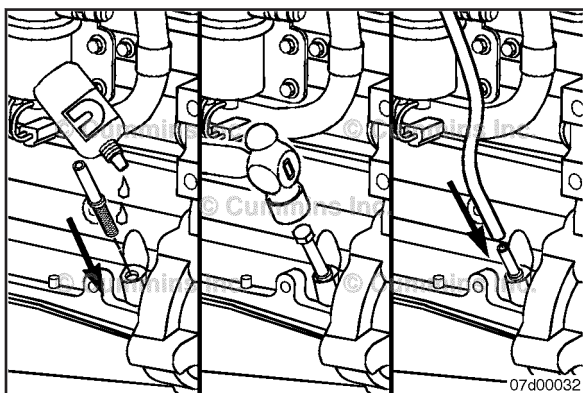

Lubricating Oil Dipstick Tube (007-011)

Install

Apply a thin bead of thread sealant around the bottom of the knurled end of the tube.

Place knurled end of tube into the dipstick tube bore in the cylinder block.

Use the dipstick tube installer tool, Part Number 3823875, to install the dipstick tube into the cylinder block.

Lightly drive the dipstick tube until it seats against the block casting.

NOTE: If a flexible tube is to be used, soak the end of the nylon tube in hot water to help ease the installation.

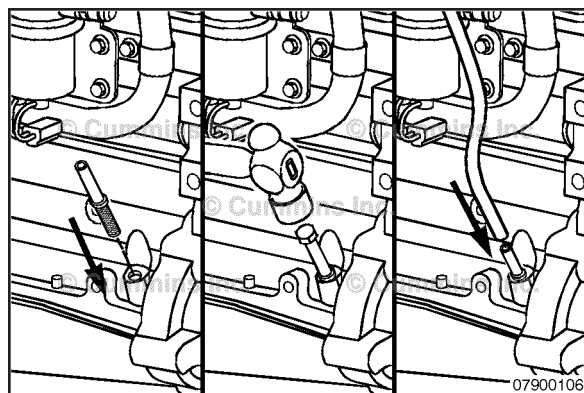

Engine Support Bracket, Rear (016-003)

Install

Install the support bracket and mounting capscrews.

Torque Value: 77 N•m [57 ft-lb]

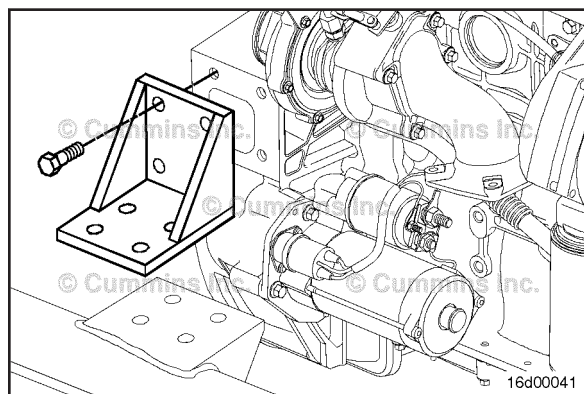

Engine Support Bracket, Front (016-002)

Install

For Front Mount, install the front mount bracket and capscrews.

Torque Value:

Grade 8.8

Step 1 80 N•m [60 ft-lb]

Torque Value:

Grade 10.9

Step 1 115 N•m [85 ft-lb]

Torque Value:

Grade 12.9

Step 1 125 N•m [95 ft-lb]

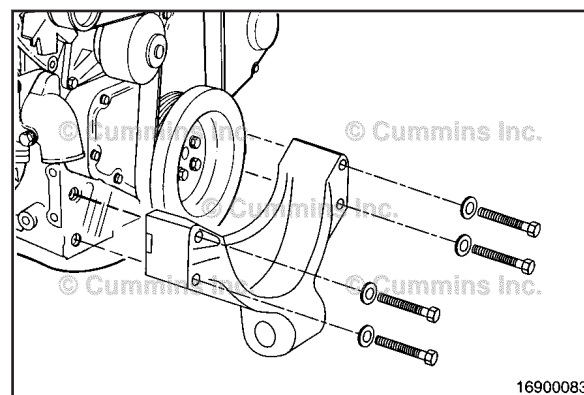

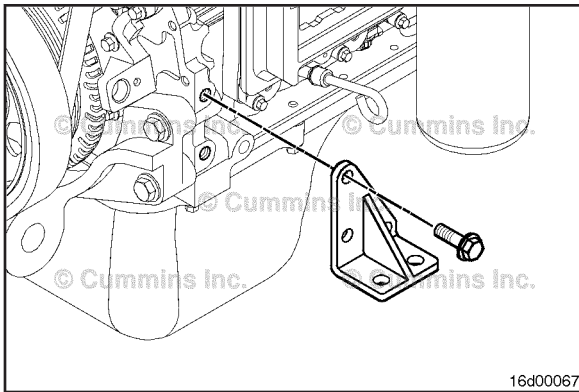

For Side Mount, install the side mount brackets and cap screws.



Torque Value:

Grade 8.8

Step 1 80 N•m [60 ft-lb]

Torque Value:

Grade 10.9

Step 1 115 N•m [85 ft-lb]

Torque Value:

Grade 12.9

Step 1 125 N•m [95 ft-lb]

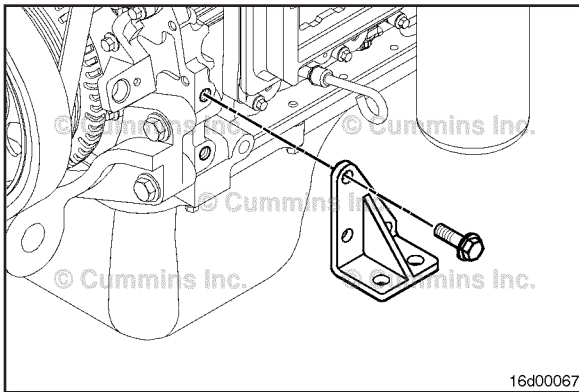

Install the vibration isolator onto the mounting bracket. Install the locking nut finger tight.

Install the side mount bracket and mounting cap screws.

Torque Value: 150 N•m [111 ft-lb]

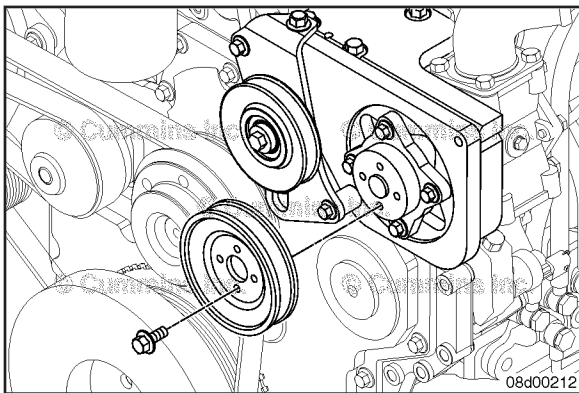

**Sea Water Pump Pulley (008-127)
Install**



Install the sea water pump pulley using four mounting cap screws.

Tighten the cap screws.

Torque Value: 10 N•m [89 in-lb]

Lubricating Oil Lines (007-092)

Install

⚠ CAUTION ⚠

When installing the lubricating oil lines, make sure the oil lines are not touching or rubbing each other or any other engine parts. Damage to the lines can result in a loss of engine lubricating oil pressure.

Install the hoses to the lubricating oil filter connectors and tighten finger tight.

Install the hose to the center (return) connection of the lubricating oil cooler housing filter adapter and tighten.

Torque Value: 76 N•m [56 ft-lb]

Install the hose to the lubricating oil cooler housing filter adapter outer (supply) connection and tighten.

Torque Value: 76 N•m [56 ft-lb]

Tighten the hoses on the filter head.

Torque Value: 76 N•m [56 ft-lb]

Operate the engine and check for leaks and proper oil pressure.

Check the lubricating oil level.

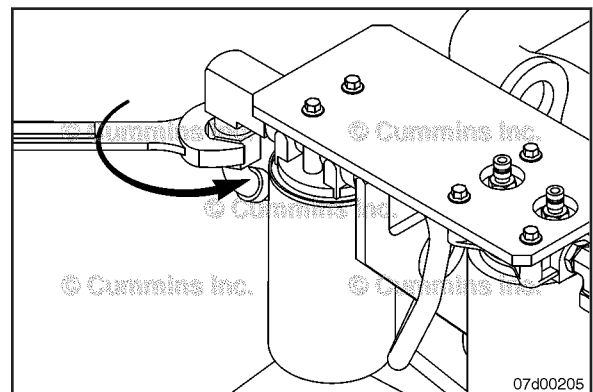
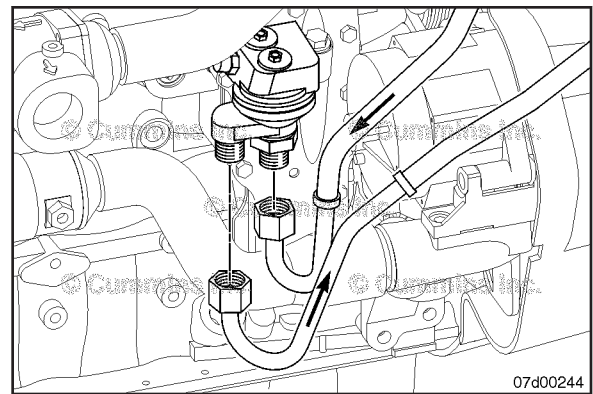

Belt Guard (008-001)

Install

NOTE: Two of the studs are attached with nuts from the rear side of the gear housing.

Install and tighten the five studs and nuts as shown.

Torque Value: 15 N•m [133 in-lb]

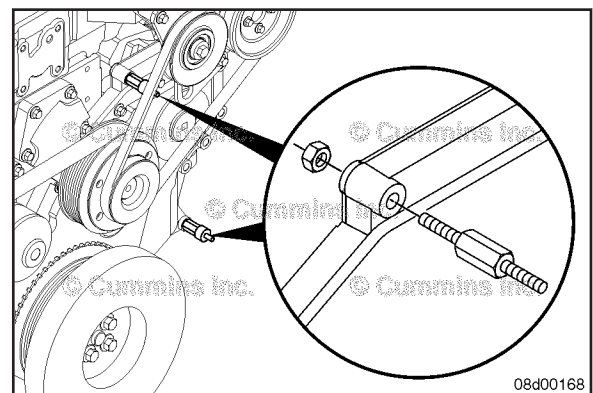

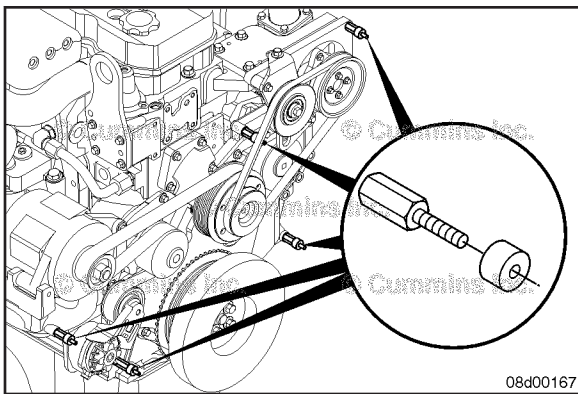

Install the five rubber isolator onto the five studs.

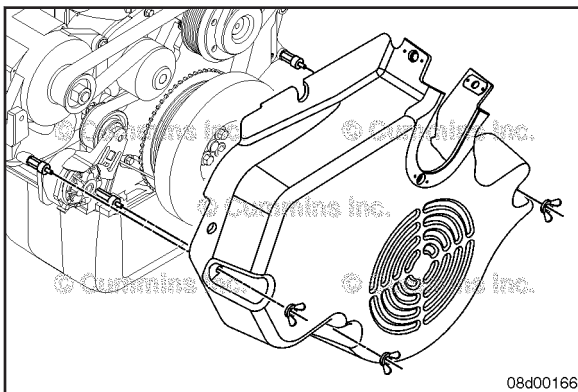

NOTE: Install the lower portion of the belt guard first, then install the upper portion of the belt guard.

Align the lower belt guard attachment holes with the three mounting studs.



Install the lower belt guard over the mounting studs.

Install and tighten the three wing nuts finger tight.

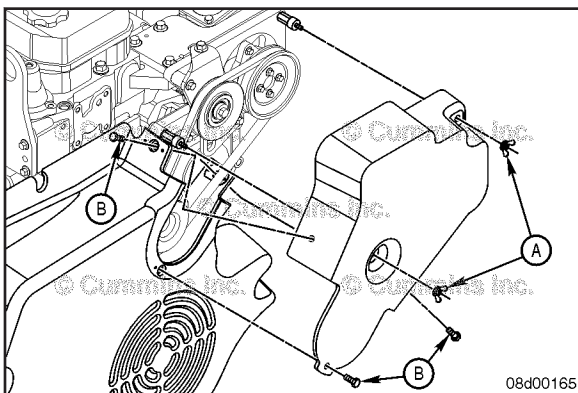

Align and install the upper belt guard to the engine.

Tighten the wing nuts (A) finger tight.



Attach the top belt guard to the lower belt guard and engine; use the three mounting cap screws (B).

Torque Value: 5 N·m [44 in-lb]

Section 0 - Product - Group 00

Section Contents

	Page
Engine Installation	0-9
General Information.....	0-9
Install.....	0-9
Engine Mounting Bolts	0-23
Inspect for Reuse.....	0-23
Engine Painting	0-22
Preparatory Steps.....	0-22
Engine Removal	0-2
General Information.....	0-2
Remove.....	0-2
Engine Steam Cleaning	0-23
Clean.....	0-23
Engine Storage - Long Term	0-19
General Information.....	0-19
Service Tools	0-1
Engine Removal and Installation.....	0-1

This Page Left Intentionally Blank

Service Tools

Engine Removal and Installation

The following special tools are recommended to perform procedures in this section. The use of these tools is shown in the appropriate procedure. These tools can be purchased from a local Cummins® Authorized Repair Location.

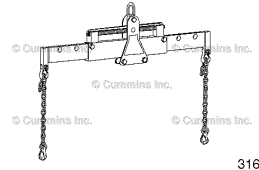
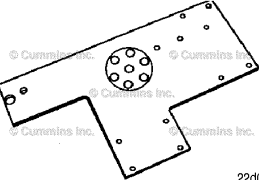
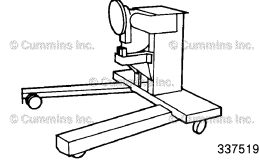
Tool No.	Tool Description	Tool Illustration
<p>3162871</p>	<p>Engine Lifting Fixture Used to remove and install the engine.</p>	 <p>3162871</p>
<p>3163625</p>	<p>Engine Stand Adapter Plate Used to mount the engine to the rebuild stand.</p>	 <p>22d00144</p>
<p>3375194 or 3375193</p>	<p>Engine Rebuild Stand Tilt type of engine rebuild stand: 3375194 — Portable, 3375193 — Stationary</p>	 <p>3375194</p>

Engine Removal (000-001)

General Information

Installations can vary from OEM to OEM. Use the following steps as a guideline. Reference the OEM manual when necessary.

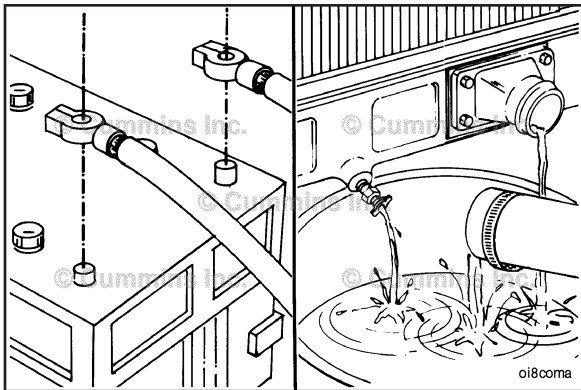

Remove

⚠ WARNING ⚠

Batteries can emit explosive gases. To reduce the possibility of personal injury, always ventilate the compartment before servicing the batteries. To avoid arcing, remove the negative (-) battery cable first and attach the negative (-) battery cable last.

⚠ WARNING ⚠

Coolant is toxic. Keep away from pets and children. If not reused, dispose of in accordance with local environmental regulations.

⚠ WARNING ⚠

Do not remove the pressure cap from a hot engine. Wait until the temperature is below 50°C [120°F] before removing the pressure cap. Heated coolant spray or steam can cause personal injury.

Disconnect the battery cables, negative (-) cable first.

Drain the engine coolant. Refer to Procedure 008-018

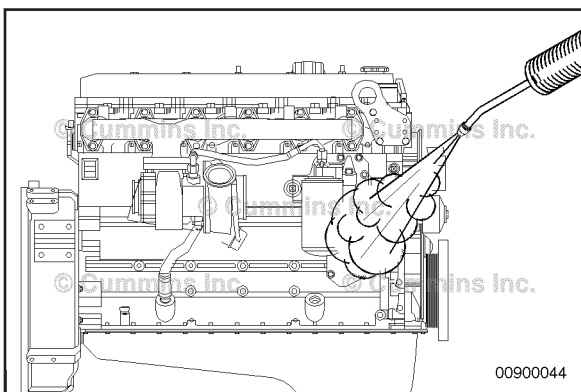

Steam clean the engine. Refer to Procedure 000-009

▲ WARNING ▲

Fuel is flammable. Keep all cigarettes, flames, pilot lights, arcing equipment, and switches out of the work area and areas sharing ventilation to reduce the possibility of severe personal injury or death when working on the fuel system.

Shut off and cap the fuel supply line and fuel return line.

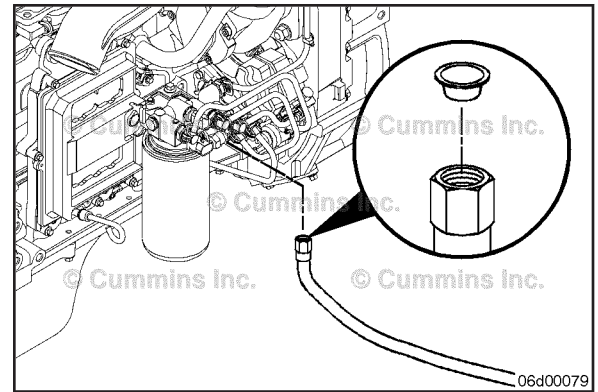

Place a tag on all hoses, lines, linkage, and electrical connections as they are removed to identify their locations.

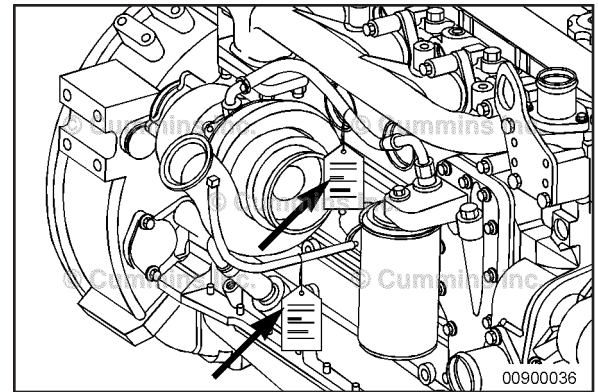

▲ WARNING ▲

Some state and federal agencies have determined that used engine oil can be carcinogenic and can cause reproductive toxicity. Avoid inhalation of vapors, ingestion, and prolonged contact with used engine oil.

▲ WARNING ▲

To reduce the possibility of personal injury, avoid direct contact of hot oil with your skin.

Drain the lubricating oil. Refer to Procedure 007-037

Disconnect the starter cable, engine ground straps, cab or chassis to engine hoses, tubing, electrical wires, wire harnesses, and hydraulic lines.

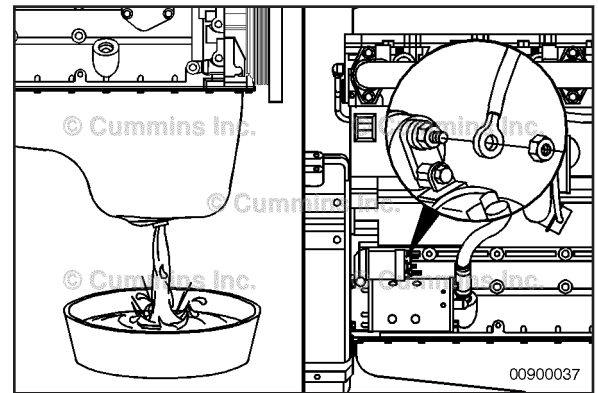

Disconnect the intake and exhaust pipes from the turbocharger. Refer to Procedure 010-022 and Refer to Procedure Procedure 011-017

Disconnect all chassis-mounted engine-driven accessories.

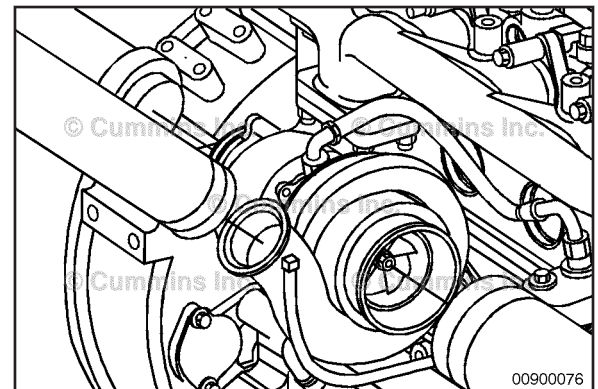

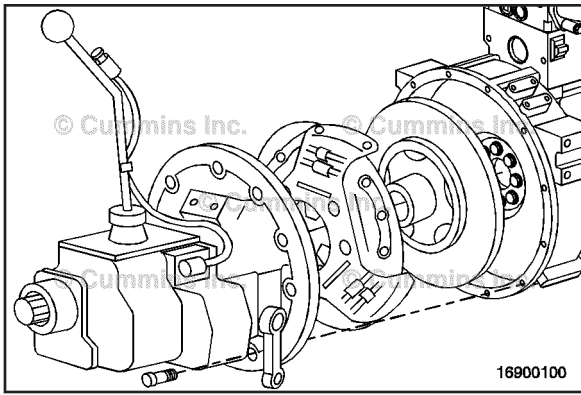

Disconnect the drive units from the flywheel housing. Refer to the OEM manual for instructions.

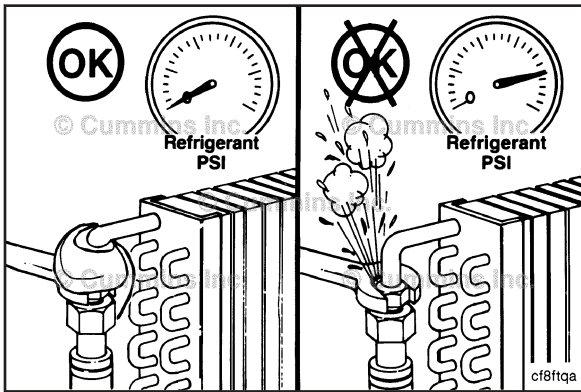

⚠ WARNING ⚠

If a liquid refrigerant system (air conditioning) is used, wear eye and face protection, and wrap a cloth around the fittings before removing. Liquid refrigerant can cause serious eye and skin injury.

NOTE: For environmental protection, federal regulations require that liquid refrigerant be recycled and **not** vented into the atmosphere. If equipped with a refrigerant compressor, check if there is enough refrigerant hose length to tie and support the compressor on the chassis to prevent the need to evacuate the refrigerant system for engine removal.

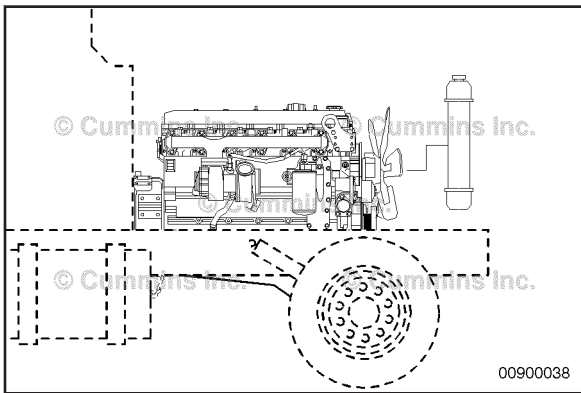

Remove all chassis components necessary to remove the engine from the equipment.

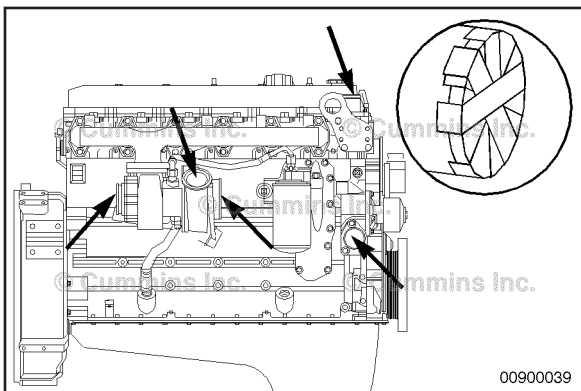

Cover all engine openings to prevent dirt and debris from entering the engine.

⚠ WARNING ⚠

The engine lifting equipment must be designed to lift the engine and transmission safely as an assembly without causing personal injury. The dry weight of the standard 4 cylinder engine without accessories is 318 kg [700 lb.]. The dry weight of the standard 6 cylinder engine without accessories is 544 kg [1200 lb].

⚠ CAUTION ⚠

If the transmission is not removed, place a support under the transmission to prevent it from falling before removing the engine.

Refer to Procedure 018-015 for engine weight specifications.

Use a properly rated hoist and engine lifting fixture, Part Number 3162871, attached to the engine-mounted lifting brackets, to remove the engine.

NOTE: When removing the rear engine mount fasteners, keep track of the location of any shims or spacers used.

Remove the engine mount fasteners.

NOTE: On applications in which the rear engine mounts are attached to the transmission, it is often necessary to remove the engine and transmission as an assembly. Refer to the OEM's manual for instructions.

Remove the engine from the vehicle.

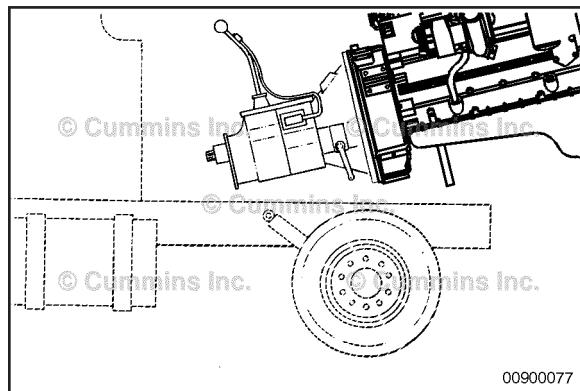
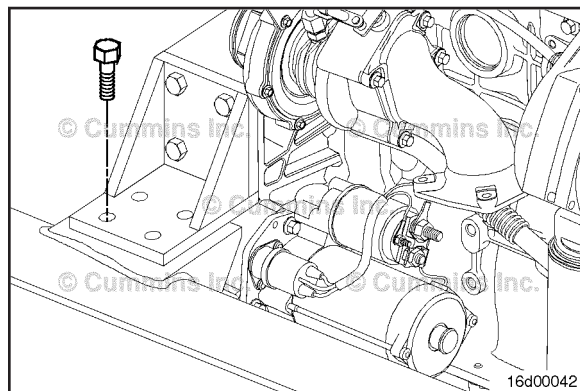
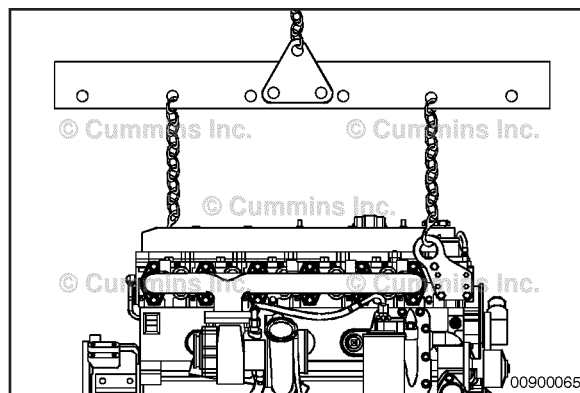

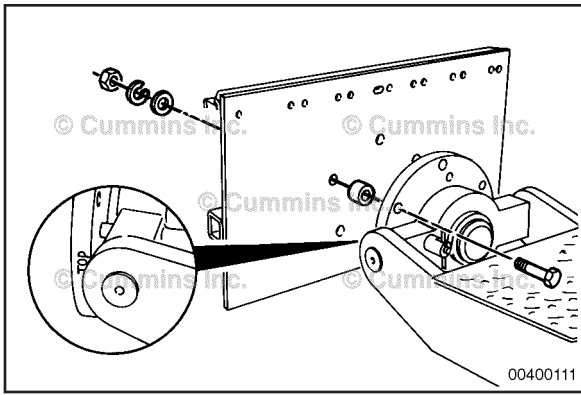

If the engine will be repaired, mount the engine stand adapter plate, part number 3163625, to the exhaust side of the engine.

NOTE: The turbocharger may need to be removed to install the engine stand adapter plate. Refer to Procedure Procedure 010-033

Mount the engine stand adapter plate to the Portable tilt type of engine rebuild stand, Part Number 3375194 or 3375193.

If the engine will be replaced, mount the engine on an appropriate shipping pallet.

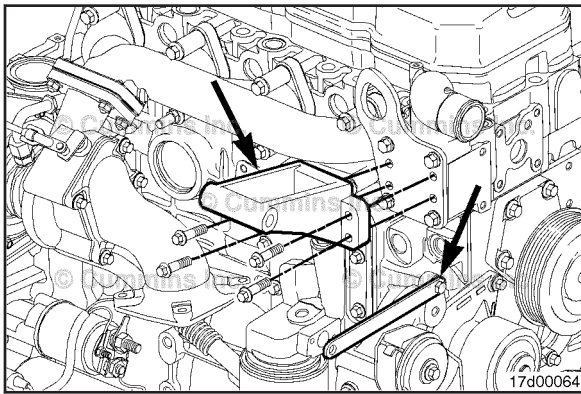

If the engine is to be replaced, remove all remaining accessories, brackets, and drive units that will be used with the replacement engine.

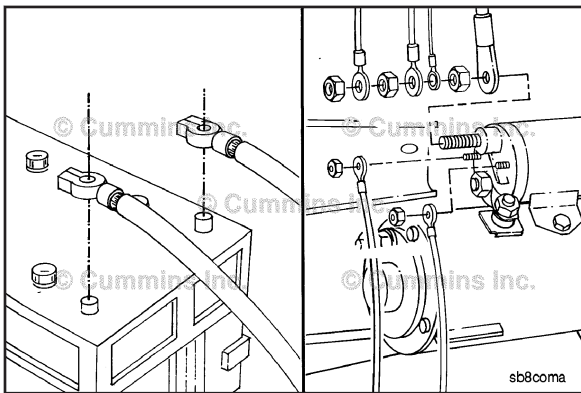

⚠ WARNING ⚠

Batteries can emit explosive gases. To reduce the possibility of personal injury, always ventilate the compartment before servicing the batteries. To avoid arcing, remove the negative (-) battery cable first and attach the negative (-) battery cable last.

⚠ CAUTION ⚠

If the vessel remains in the water while the engine is being removed, make sure all sump or bilge pumps are operational while the engine is removed to prevent the vessel from taking on water and possibly sinking.

Disconnect the battery cables, (-) negative cable first. Disconnect all unswitched power connections from the batteries and engine.

Disconnect and tag the starter cable, engine ground straps, vessel or vessel to engine hoses, tubing, electrical wires, wire harnesses, and hydraulic lines.

▲WARNING▲

Fuel is flammable. Keep all cigarettes, flames, pilot lights, arcing equipment, and switches out of the work area and areas sharing ventilation to reduce the possibility of severe personal injury or death when working on the fuel system.

Shut off, disconnect, and cap the fuel supply line and fuel return line from the engine to the fuel tank(s).

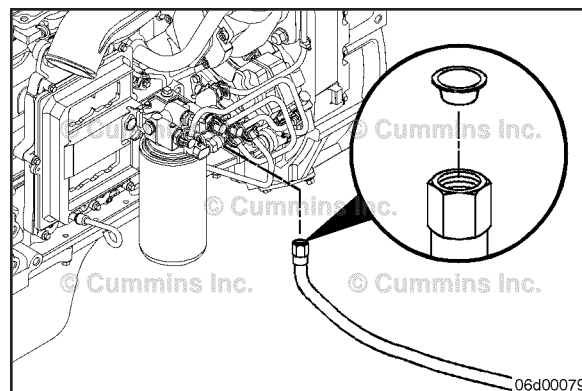

▲CAUTION▲

Zinc plugs expand and can break off during removal. Inspect the zinc plug to make sure it is in one piece. If not, it must be replaced with a new zinc plug, and the broken pieces must be retrieved from the aftercooler to prevent damage to components downstream in the sea water system.

Shut off the sea water supply line(s). Drain the sea water system by removing the lower zinc plug from the aftercooler.

Disconnect the sea water supply lines.

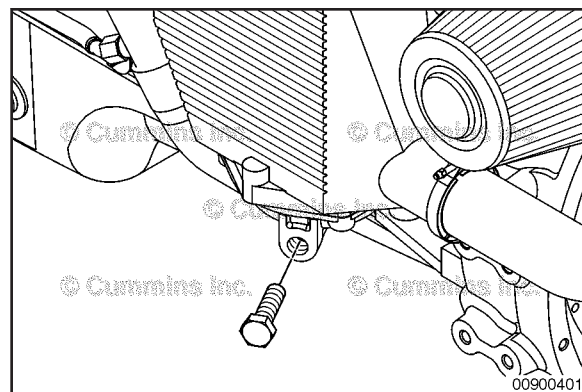

▲CAUTION▲

Be sure to tie the exhaust piping up above the water line to prevent water from feeding back into the vessel while the exhaust piping is removed. Failure to do so can result in the vessel sinking.

Disconnect the exhaust piping from the exhaust outlet connection on the turbocharger.

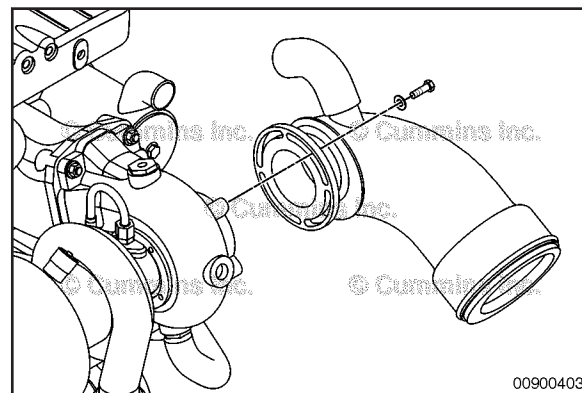

▲WARNING▲

Coolant is toxic. Keep away from pets and children. If not reused, dispose of in accordance with local environmental regulations.

▲WARNING▲

Do not remove the pressure cap from a hot engine. Wait until the temperature is below 50°C [120°F] before removing the pressure cap. Heated coolant spray or steam can cause personal injury.

Drain the engine coolant. Refer to Procedure 008-018

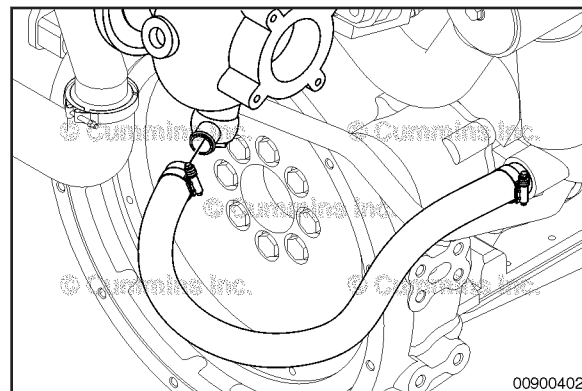

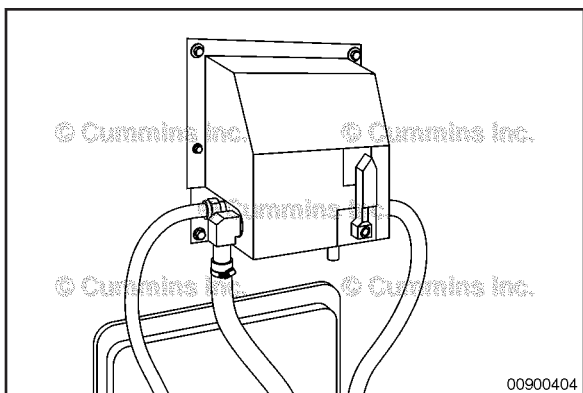

⚠ WARNING ⚠
Some state and federal agencies have determined that used engine oil can be carcinogenic and can cause reproductive toxicity. Avoid inhalation of vapors, ingestion, and prolonged contact with used engine oil.

⚠ WARNING ⚠
To reduce the possibility of personal injury, avoid direct contact of hot oil with your skin.

Drain the lubricating oil Refer to Procedure 007-037

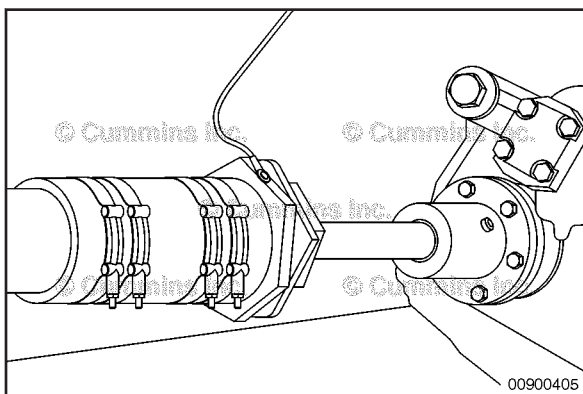

Disconnect the transmission output shaft from the drive coupling. Refer to the OEM service manual.

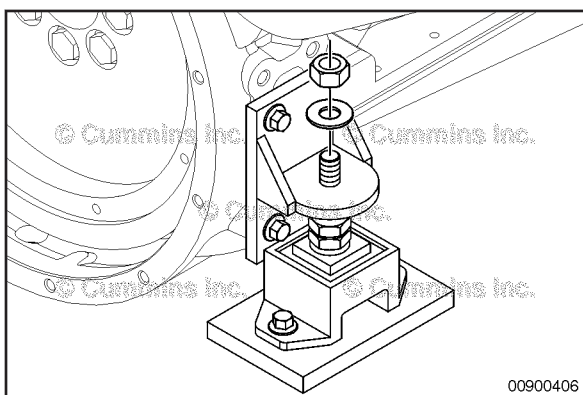

Remove the engine mounting nuts from the engine mounts.

Remove all components necessary to remove the engine from the vessel.

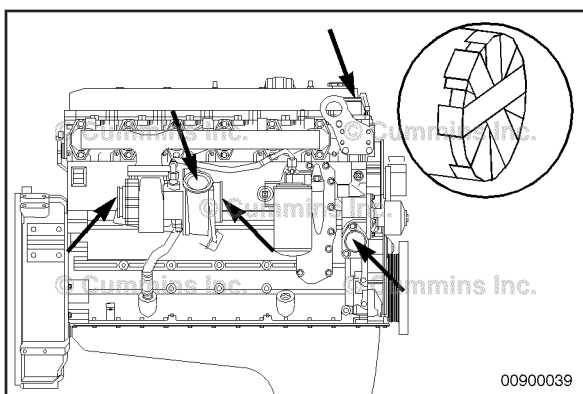

Cover all engine openings to prevent dirt and debris from entering the engine.

⚠ WARNING ⚠

The engine lifting equipment must be designed to lift the engine and transmission safely as an assembly without causing personal injury. The dry weight of the standard QSB5.9 marine engine with heat exchanger and without transmission is 588 kg [1296 lb].

Refer to Procedure 018-015 for engine weight specifications. Refer to the Marine Gear OEM service manual for marine gear weight specifications.

Use a properly rated hoist and engine lifting fixture, Part Number 3162871, attached to the engine-mounted lifting brackets, to remove the engine.

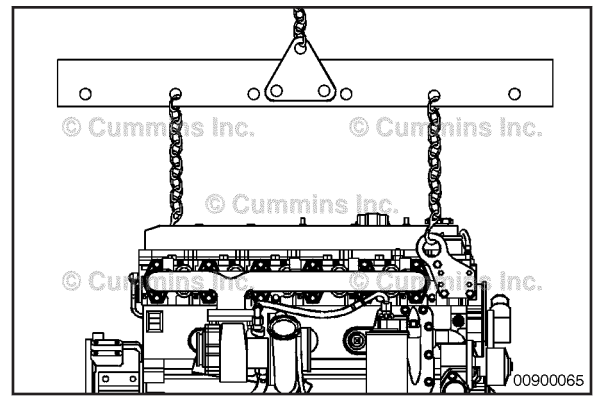

If the engine is to be replaced, remove all remaining accessories, brackets, and drive units that will be used with the replacement engine.

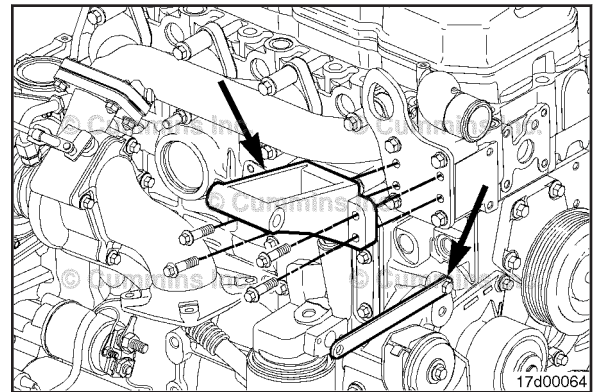

Engine Installation (000-002)

General Information

Installations can vary from OEM to OEM. Use the following steps as a guideline. Reference the OEM manual when necessary.

Install

Automotive and Industrial

Install all accessories and brackets that were removed from the engine during engine removal.

For engine supplied components, reference the corresponding procedure in this manual.

For vehicle installed components, reference the corresponding OEM Manual.

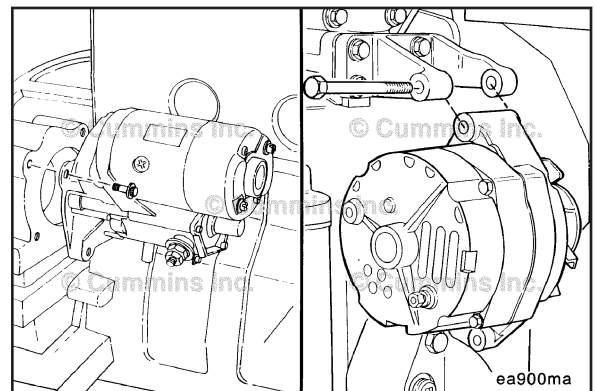

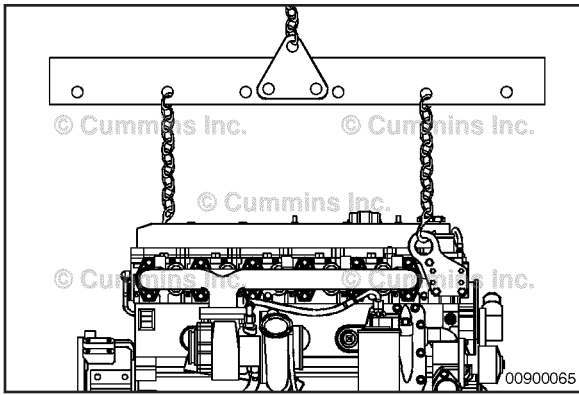

⚠ WARNING ⚠

The engine lifting equipment must be designed to lift the engine and transmission safely as an assembly without causing personal injury. The dry weight of the standard 4 cylinder engine without accessories is 318 kg [700 lb]. The dry weight of the standard 6 cylinder engine without accessories is 544 kg [1200 lb].



Refer to Procedure 018-015 for engine weight specifications.

Use a properly rated hoist and engine lifting fixture, Part Number 3162871, attached to the engine-mounted lifting brackets, to install the engine.

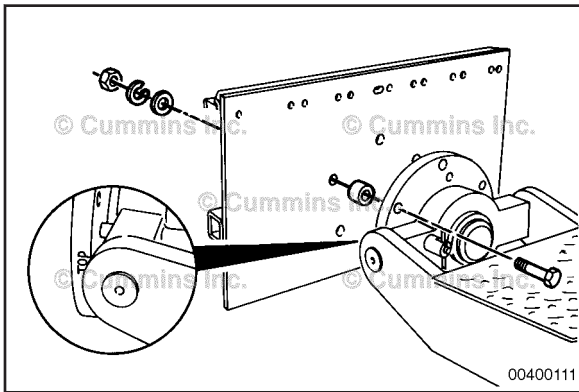

If the engine was repaired, lift the engine and engine stand adapter plate from the engine rebuild stand.

Remove the engine stand adapter plate.

NOTE: The turbocharger may need to be installed after the engine stand adapter plate is removed. Refer to Procedure 010-033 in Section 10.

If the engine was replaced, lift the engine from the shipping pallet.

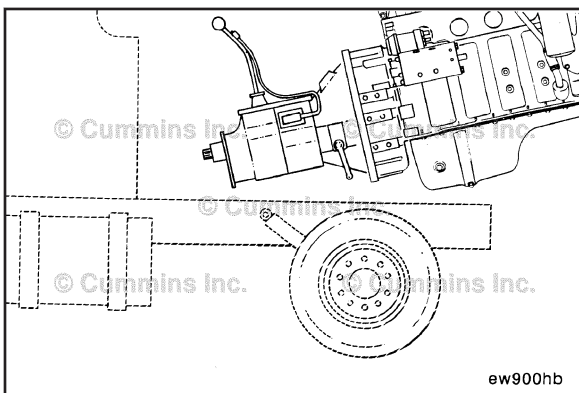

NOTE: On applications in which the rear engine mounts are attached to the transmission, it is often necessary to install the engine and transmission as an assembly. Refer to the OEM manual for instructions.

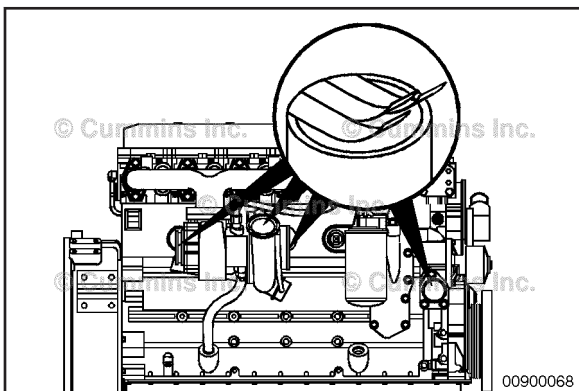

Remove covers from all openings that were covered during removal.

Align the engine in the chassis, and tighten the engine mounting capscrews. Reference the OEM's torque specifications.



Connect all engine- and chassis-mounted accessories that were removed.



NOTE: Make sure all lines, hoses, and tubes are properly routed and fastened to prevent damage. Make sure the air intake and exhaust pipe connections are tight and free of leaks.

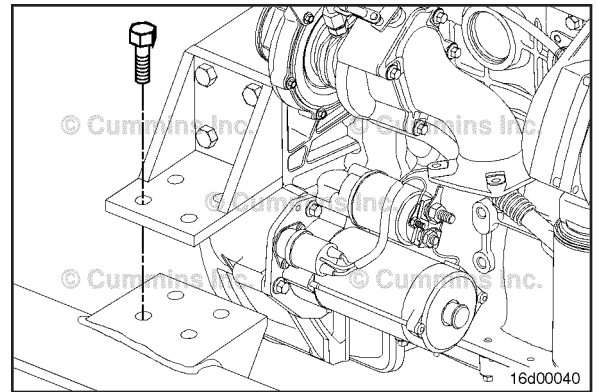

If not installed with the engine, connect the drive units to the flywheel housing. Reference the OEM manual for instructions.

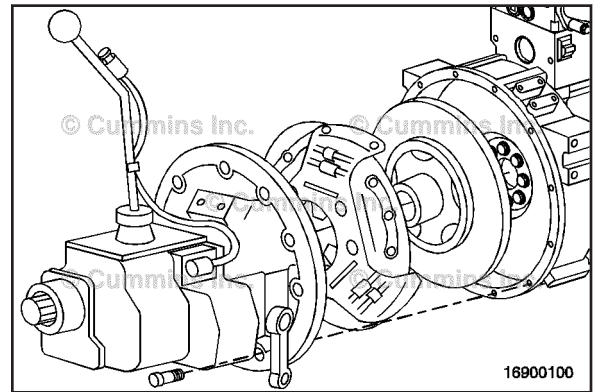

Fill the engine with clean 15W-40 engine oil. Refer to Procedure 007-037 in Section 7.

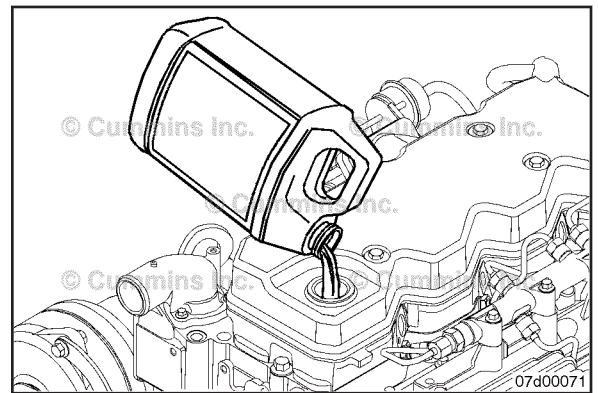

NOTE: On engines with EGR, the pipe plug in the EGR coolant line **must** be removed during filling.

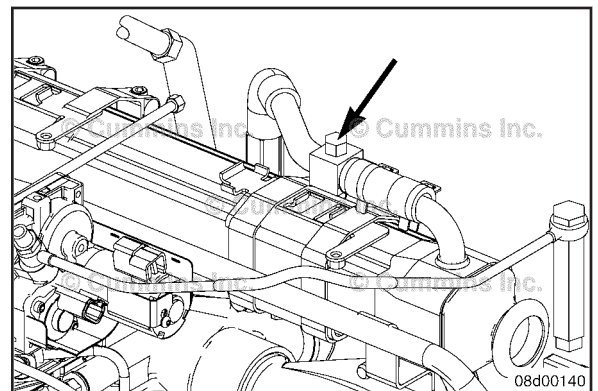

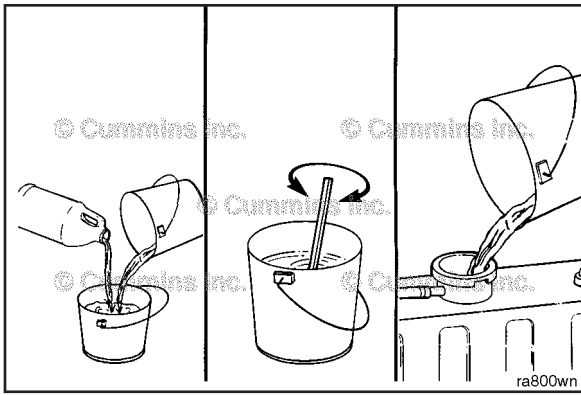

NOTE: The total coolant capacity of the engines varies. Refer to the original equipment manufacturer's instructions to determine the capacity of the whole cooling system.

Fill the cooling system with new coolant. Refer to Procedure 008-018 in Section 8.

Refer to Procedure 018-018 for cooling system specifications.

On engines with EGR, install the pipe plug in the EGR coolant line after filling with coolant.

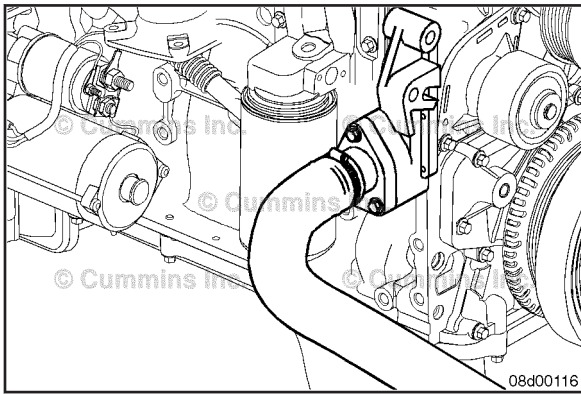

CAUTION

Installation of the cooling system pressure cap at this point is critical for proper purging of air trapped in the cooling system. Improper purging of air from the cooling system will result in engine damage from overheating.

Perform a final inspection to make sure all hoses, wires, linkages, and components have been properly installed and tightened.

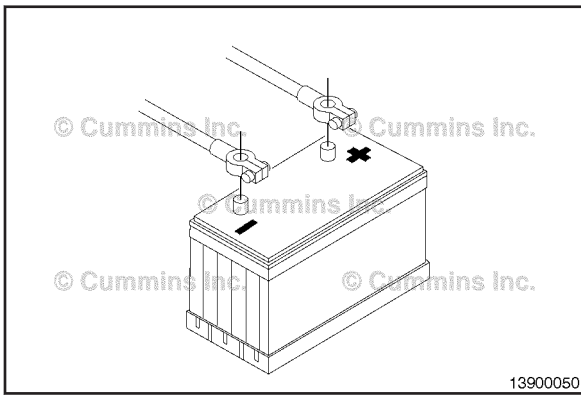

WARNING

Batteries can emit explosive gases. To reduce the possibility of personal injury, always ventilate the compartment before servicing the batteries. To reduce the possibility of arcing, remove the negative (-) battery cable first and attach the negative (-) battery cable last.

Connect the batteries.

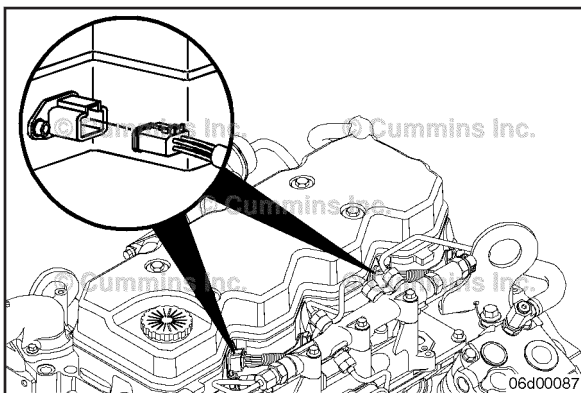

Disconnect the engine injector harness connectors at the rocker housing to make sure the engine will **not** start.

⚠ CAUTION ⚠

The lubricating oil system must be primed before operating the engine after it has been repaired or rebuilt to avoid internal damage.

Install a pressure gauge in the main oil rifle on the intake side of the engine to measure oil pressure.

If a port on the main oil rifle is **not** available, install a pressure gauge at the top of the oil filter head.

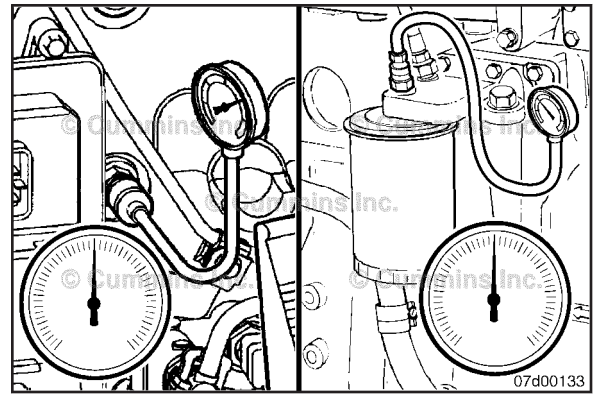

⚠ CAUTION ⚠

Do not engage the starting motor for more than 30 seconds. To reduce the possibility of engine damage, wait 2 minutes between starter engagements to cool the starting motor.

Crank the engine until the lubricating oil pressure gauge indicates a positive pressure.

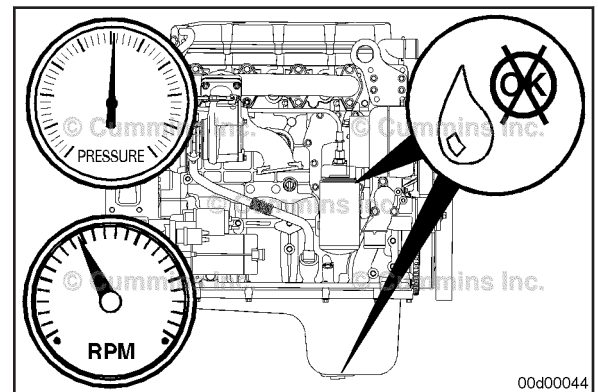

After pressure is observed, connect the engine harness injector connector at the rocker housing.

Remove the pressure gauge.

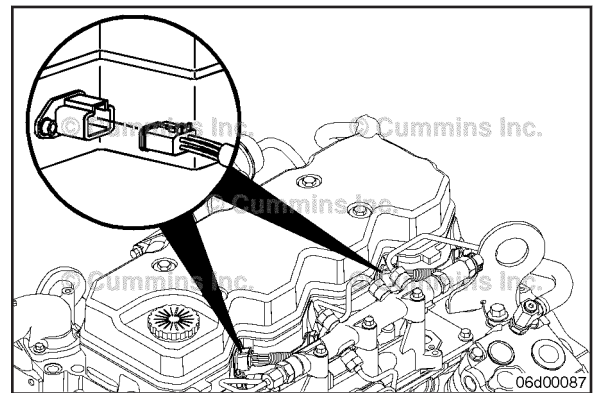

Prime the fuel system. Refer to Procedure 005-016 in Section 5.

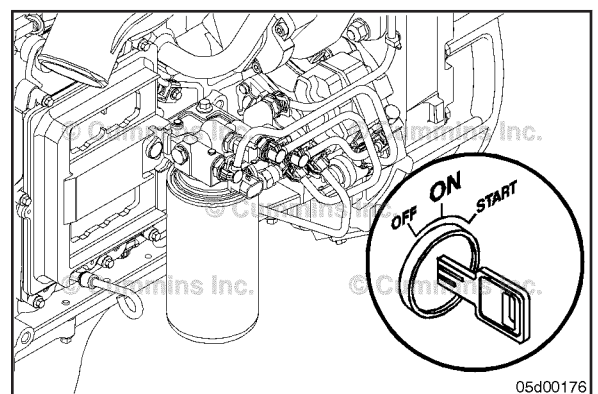

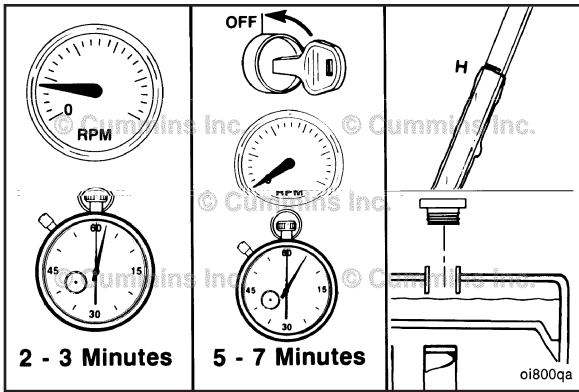

WARNING

Do not remove the pressure cap from a hot engine. Wait until the coolant temperature is below 50°C [120°F] before removing the pressure cap. Heated coolant spray or steam can cause personal injury.

Operate the engine at low idle for 2 to 3 minutes.

Shut off the engine and wait 5 to 7 minutes for the lubricating oil to drain to the lubricating oil pan.

Check the lubricating oil and coolant levels again.

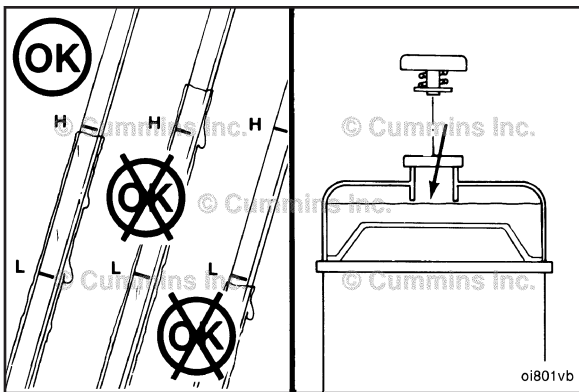

Fill the engine to the correct lubricating oil and coolant levels, if necessary. Refer to Procedure 007-037 and Refer to Procedure 008-018

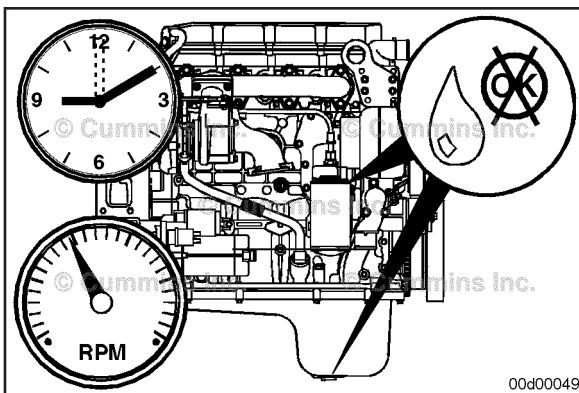

Operate the engine at 1000 to 1200 rpm for 8 to 10 minutes.

Check for proper operation, unusual noises, and coolant, fuel, or lubricating oil leaks.

Repair all leaks and component problems.

See Section 14 for the Engine Run-In and Test Procedures.

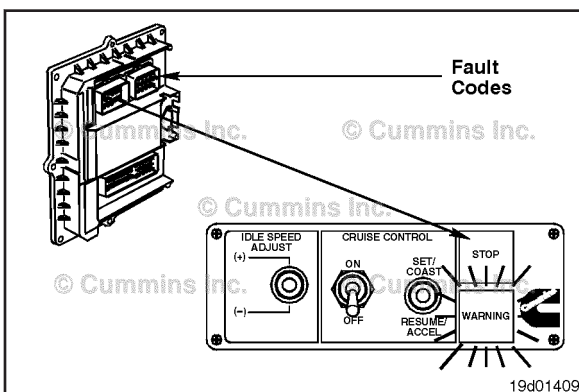

Use INSITE™ service tool to read and clear any fault codes. See the appropriate electronic controls manual for the engine being serviced.

Marine Applications

NOTE: Installations can vary from OEM to OEM. See Marine Recreational B and C Installation Directions, Bulletin 3884649 for more detailed instructions for your engine and application.

Install all accessories, brackets, and drive units that were removed from the engine, if the engine is being replaced.

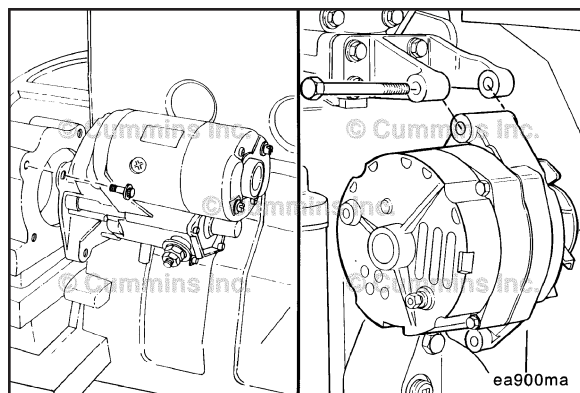

⚠ WARNING ⚠

The engine lifting equipment must be designed to lift the engine and transmission safely as an assembly without causing personal injury. The dry weight of the standard QSB5.9 marine engine with heat exchanger and without transmission is 588 kg [1296 lb].

Refer to Procedure 018-015 for engine weight specifications. Refer to the Marine Gear OEM service manual for marine gear weight specifications.

Use a properly rated hoist and engine lifting fixture, Part Number 3162871, attached to the engine-mounted lifting brackets, to install the engine.

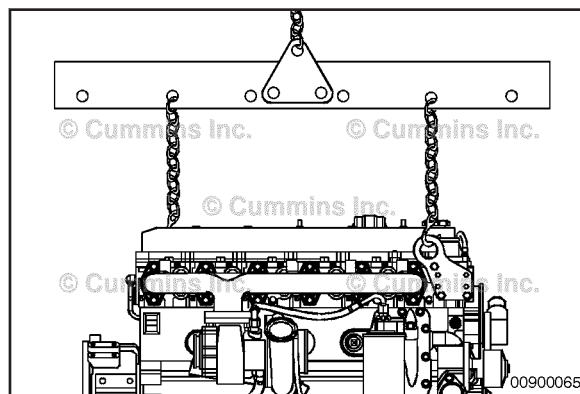

Remove covers from all engine openings that were covered during engine removal.

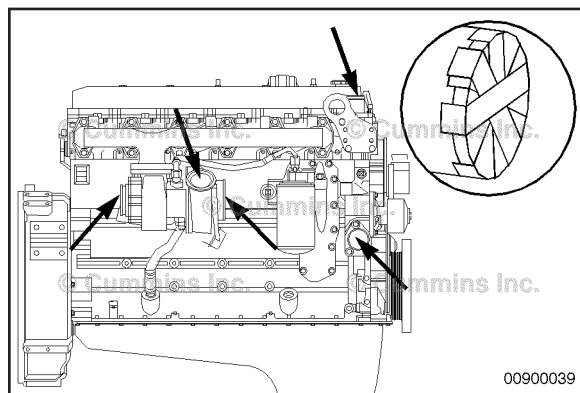

Align the engine in the vessel and tighten the engine mounting capscrews. Reference the OEM for torque specifications.

See Marine Recreational B and C Installation Directions, Bulletin 3884649.

Connect all engine and vessel-mounted components accessories.

Make sure all sea water and fuel lines, hoses, and tubes are properly routed and fastened to prevent damage. Make sure the exhaust pipe connections are tight and free of leaks.

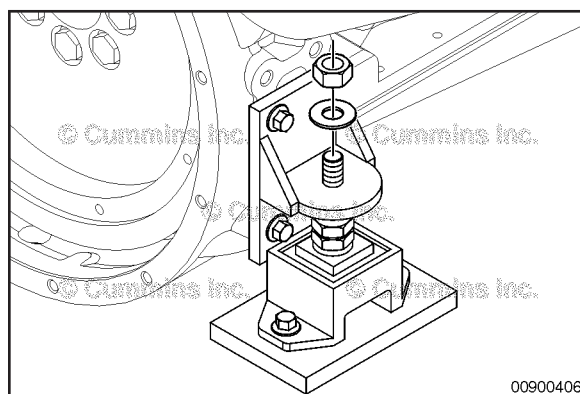

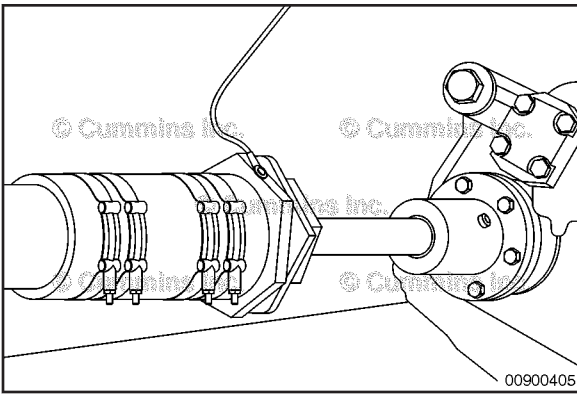

NOTE: The output shaft **must** be aligned when installed. Refer to the OEM for specifications.

Connect the transmission output shaft to the drive coupling. Refer to the OEM service manual.

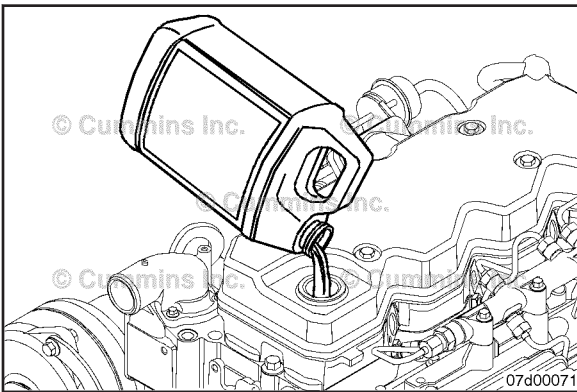

NOTE: If this is a new engine installation, the dipstick will need to be calibrated. Refer to Procedure 007-009

Fill the engine with clean 15W-40 engine oil. Refer to Procedure 007-037

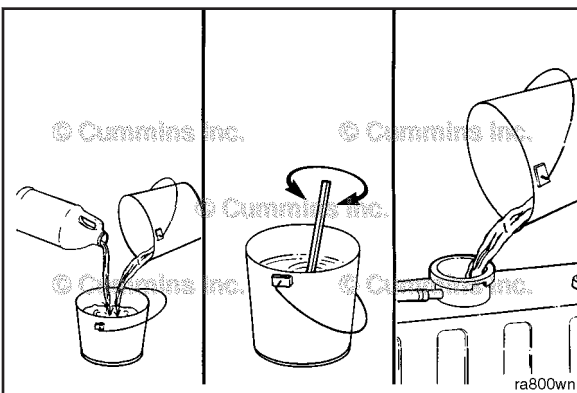

NOTE: The total coolant capacity of the engines varies. Refer to the original equipment manufacturer's instructions to determine the capacity of the whole cooling system.

Fill the cooling system with new coolant. Refer to Procedure 008-018.

Refer to the engine data sheet to determine the capacity of the whole cooling system.

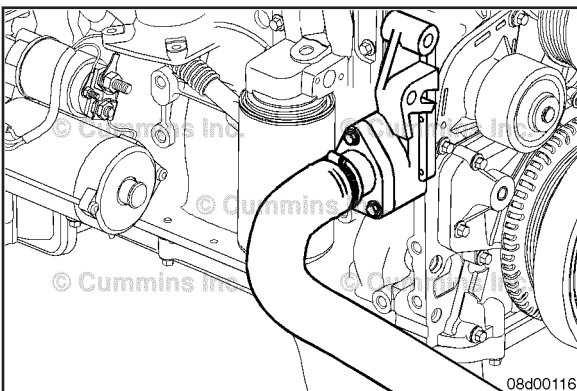

⚠ CAUTION ⚠

Leave the pressure cap off or loose until air can be purged out of the cooling system. Improper purging of air from the cooling system will result in engine damage from overheating. If the vessel is equipped with a cabin heater or remote heat exchanger units, it will take longer for the trapped air to purge.

Perform a final inspection to make sure all hoses, wires, linkages, and components have been properly installed and tightened.

Make sure all alarms and lights are working prior to starting the engine.

⚠ CAUTION ⚠

To prevent damage to the sea water pump, open the sea water valves before engaging the starting motor. Rotation of the sea water pump impeller with no water can damage the impeller.

Open the sea water supply lines.

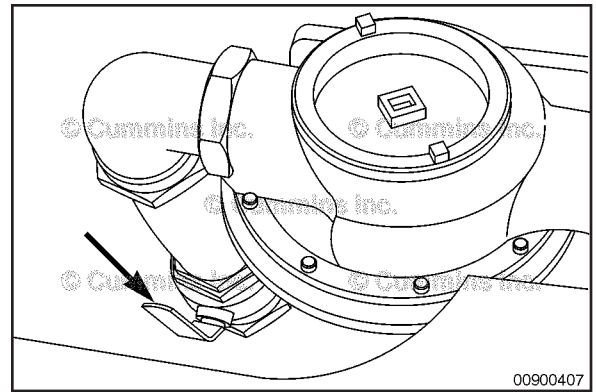

NOTE: This procedure will cause fault codes to be logged in the electronic control module (ECM). These faults will need to be removed prior to placing the engine in service. See the appropriate electronic controls manual for the engine being serviced.

Disconnect the engine injector harness connectors at the rocker housing to make sure the engine will **not** start.

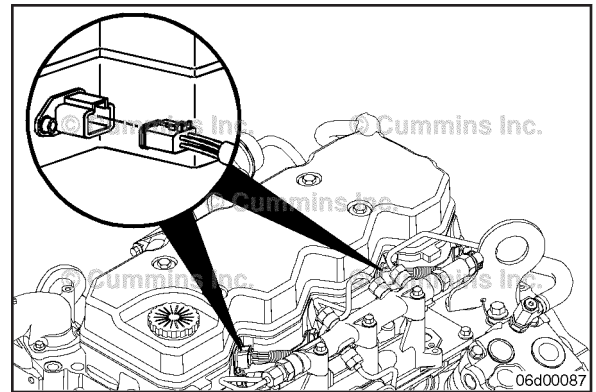

⚠ CAUTION ⚠

Do not engage the starting motor for more than 30 seconds. To reduce the possibility of engine damage, wait two minutes between starter engagements to cool the starting motor.

Crank the engine until the lubricating oil pressure gauge indicates a positive pressure.

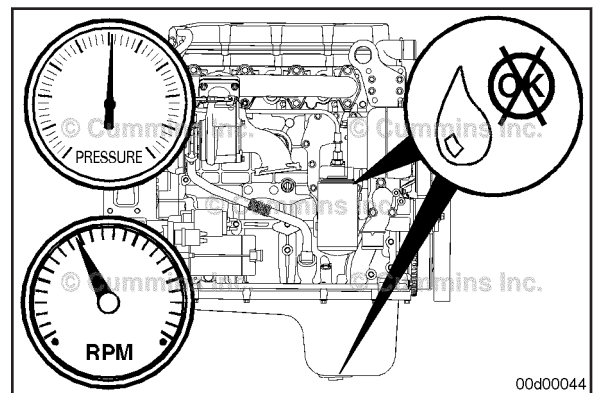

After pressure is observed, connect the engine harness injector connectors at the rocker housing.

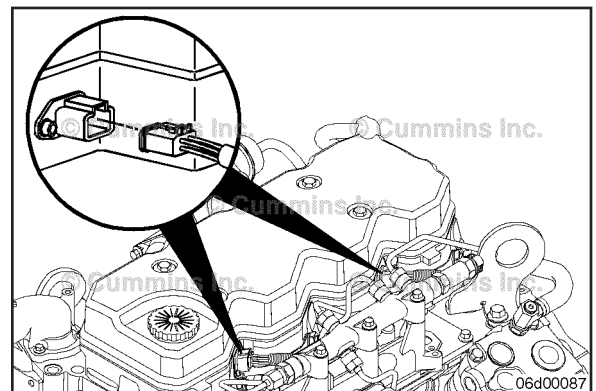

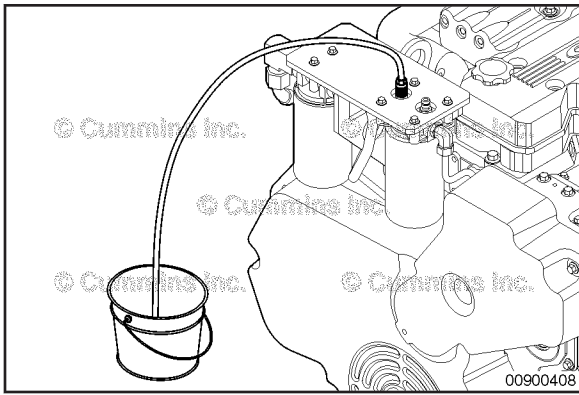

CAUTION

Use caution when disconnecting or removing fuel lines, replacing filters and priming the fuel system that fuel is not spilled or drained into the bilge area. Do not drop or throw filter elements into the bilge area. The fuel and fuel filters must be discarded in accordance with local environmental regulations.

Open the fuel filter outlet fitting to purge air from the fuel system. Refer to Procedure 005-016 for priming the fuel system.

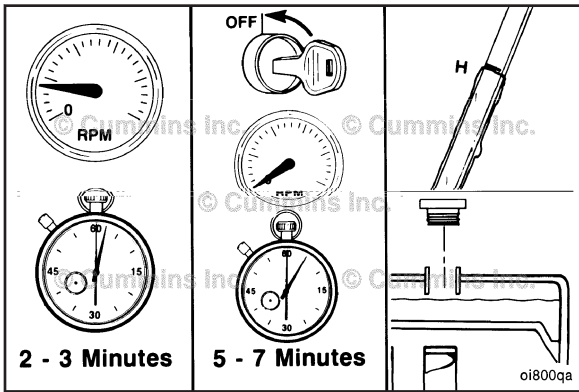

WARNING

Do not remove the pressure cap from a hot engine. Wait until the coolant temperature is below 50°C [120°F] before removing the pressure cap. Heated coolant spray or steam can cause personal injury.



Operate the engine and check for sea water flow. Be sure the marine gear is in neutral and the engine can shift in and out of gear.

Operate the engine at low idle for two to three minutes.

Shut off the engine and wait five to seven minutes for the lubricating oil to drain to the lubricating oil pan.

Check the lubricating oil and coolant levels again.

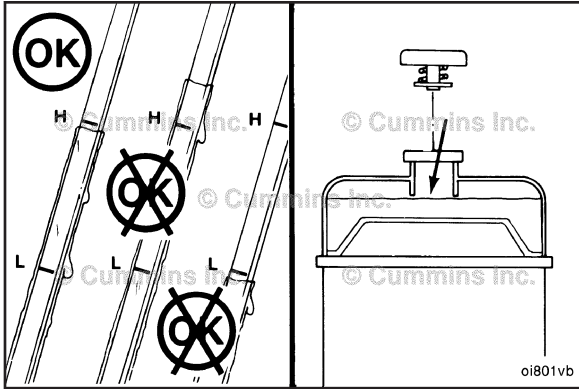

Fill the engine to the correct lubricating oil and coolant levels, if necessary. Refer to Procedure 007-037 and Refer to Procedure 008-018

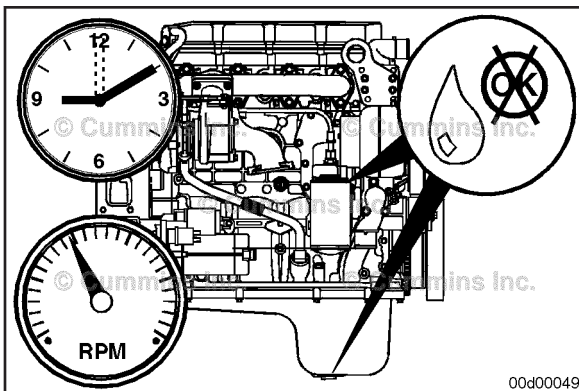

Operate the engine at 1000 to 1200 rpm for eight to ten minutes.



Check for proper operation, unusual noises, and coolant, fuel, or lubricating oil leaks.

Repair all leaks and component problems.



Refer to Procedure 014-008 for the Engine Run-In and Test Procedures.

Use INSITE™ electronic service tool to read and clear any fault codes. 

See the appropriate electronic controls manual for the engine being serviced.

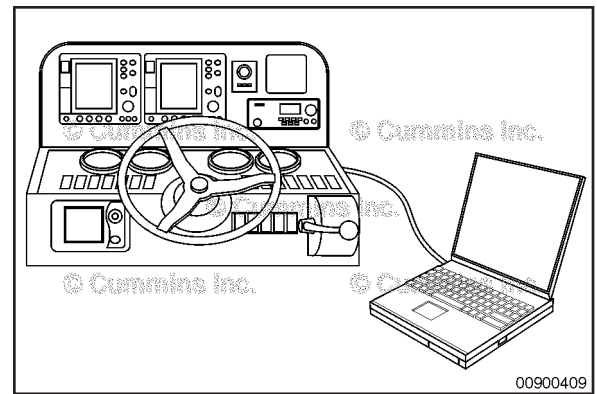

Engine Storage - Long Term (000-005)

General Information

⚠ WARNING ⚠

Do not remove the pressure cap from a hot engine. Wait until the coolant temperature is below 50°C [120°F] before removing the pressure cap. Heated coolant spray or steam can cause personal injury.

⚠ WARNING ⚠

Coolant is toxic. Keep away from children and pets. If not reused, dispose of in accordance with local environmental regulations.

⚠ CAUTION ⚠

After 24 months in storage, the engine cooling system must be drained and flushed with a suitable solvent or a hot, lightweight mineral oil. Repeat flushing procedure a second time before being put back into service.

This procedure describes the proper method for the long-term (more than 6 months) storage of an engine that is currently in running condition. This procedure applies to this engine either remaining in chassis - or being removed out of chassis upon completion of the steps below.

Prepare the Engine for Long Term Storage

⚠ CAUTION ⚠

DO NOT use fuel system preservative oil on Natural Gas or Propane Engines.

- Operate the engine at high idle until the coolant temperature is 70°C [158°F].
- Turn the engine off.
- Drain the oil.
- Install the drain plugs.
- Fill the engine oil pan sump to the high mark using Tectyl™ 910 or equivalent engine preservative oil. This will provide long term engine rust protection. The oil **must** meet military specification MIL-PRF-21260, Type P-10, Grade 2, SAE 30.

Internal Preservation of the Fuel System with Mechanically and Electronically Actuated Injectors.

⚠ CAUTION ⚠

DO NOT use diesel fuel containing bio components for internal preservation of fuel system for engine storage. Fuel properties degradation may cause damages and lead to premature failure of fuel system components.

- Disconnect the fuel lines to the engine fuel filter and the injector return line.
- Use Diesel Pump and Injector calibration fluid that meets ISO 4113 standard, SAE J967d standard and Bosch VS 15665-OL standard.

NOTE: Using calibration fluid allows storage for up to 12 months. After 12 months the engine fuel system **must** be drained and flushed again with fresh calibration fluid. Repeat after each 12-month period.

Alternatively you can use the diesel fuel with 0 percent bio components content for Internal Preservation of the Fuel System.

NOTE: Using diesel fuel with 0 percent bio components content allows storage for up to 6 months. After 6 months, the engine fuel system **must** be drained and be flushed again with fresh diesel fuel with 0 percent bio components content. Repeat after each 6-month period.

- Start the engine.
- After the engine is operating smoothly, transfer the fuel supply line to the container of calibration fluid or the container of diesel fuel with 0 percent bio components content.
- Let the engine run for approximately 25 minutes at low idle in order to ensure that the engine preservative oil (Tectyl™ 910 E or equivalent) is distributed around the engine and its internal components and that the calibration fluid or the diesel fuel with 0 percent bio components content flows out of the injector return line.
- Turn the engine "OFF".
- Connect the fuel lines to the fuel filter and the injector return line.
- Drain all the preservative oil from the engine oil pan sump, the air compressor (if applicable), and drain all the oil filters and all the fuel filters.
- Install the drain plugs.

⚠CAUTION⚠

Before starting another Internal Preservation of the Fuel System procedure again (after passing a storage period) it is required to fill the engine oil pan sump to the high mark using Tectyl™ 910 or equivalent engine preservative oil.

- If the engine is being stored as a loose engine, drain the engine coolant and cover all cooling system openings with plastic and tape.
- If the engine is **not** being removed from chassis and the engine has an extended life coolant with rust inhibitor, then coolant does **not** need to be drained.
- If the engine will remain in storage for over 24 months, the engine cooling system **must** be drained and flushed with a suitable solvent or a hot, lightweight mineral oil. Repeat after each 24-month period.
- Remove the intake and exhaust manifolds.
- Spray preservative oil into the intake and exhaust ports in the cylinder heads and in the exhaust manifolds **only**. Do **not** use preservative oil on the intake manifold or any fuel system components as this may permanently damage sensors or valves.
- Spray preservative oil in the inlet port on the air compressor (if applicable).
- Remove the rocker lever covers.
- Spray the rocker levers, the valve stems, the springs, the valve guides, the crossheads, and the push rods with preservative oil.
- Install the rocker lever covers, intake and exhaust manifolds.
- Brush or spray the preservative oil on all the exposed metal surfaces that are **not** painted. Preservative oil should **not** be applied to any plastic, rubber, or similar surfaces. Make sure to coat the flywheel, flywheel housing and all other unpainted machined surfaces with this preservative oil. Use a rust preservative oil compound that meets military specification MIL-C-16173C, type P-2, Grade 1 or 2.
- For components containing exposed bearings that are **not** easily accessible e.g. Fan Hubs, remove the component to aid access. Brush or spray preservative oil on all surfaces that are **not** painted and refit the component. Use a rust preservative oil compound that meets military specification, MIL-C-16173C, type P-2, Grade 1 or 2
- Cover all the openings (engine and components) with heavy paper and tape to prevent dirt and moisture from entering the engine. Cover the entire engine with plastic.
- Put a warning tag on the engine. The tag **must** indicate:
 - Do **not** operate the engine.
 - Do **not** bar the crankshaft.
 - The engine has been treated with preservatives.
 - The coolant has been removed.
 - The date of treatment.
 - The date of the 6 week inspection if required.



The engine must be stored in an area that is dry and has uniform temperature.

- Remove any accessory drive belts to prevent localized stretching and deformation.
- If the engine can be stored inside a designated storage facility isolated from the external environment, ignore the following step.
- Excluding the crankshaft, ensure that all external dynamic engine components are rotated every 6 weeks. Ensure parts are free from corrosion, debris and water ingress. Record and date this on the engine tag created.

Remove the Engine from Long Term Storage

To remove the engine from long term storage, follow the following steps:



To reduce the possibility of personal injury, avoid direct contact of hot oil with your skin.

- Flush the engine preservative oil out of the engine by removing the plug from the main engine oil rifle and pumping a hot, lightweight mineral oil through it. Make sure that the engine crankshaft is barred at least three to four revolutions during this flushing procedure.
- Drain all the mineral oil that was used to flush the engine clean of the engine preservative oil.
- Install the drain plugs.
- Install new oil, fuel and coolant filters.
- Fill the engine to the high mark with engine oil.
 - If the engine has been in storage for less than 24 months and if the cooling system was drained, fill the cooling system with coolant. See the Coolant Recommendations and Specifications procedure in Section V of the corresponding owners and/or operation and maintenance manual for antifreeze, water, and SCA specifications.
 - If the engine has been in storage for 24 months, every 24 months the engine cooling system **must** be drained and flushed with a suitable solvent or a hot, lightweight mineral oil. Fill the cooling system with coolant. See the Coolant Recommendations and Specifications procedure in Section V of the corresponding owners and/or operation and maintenance manual for antifreeze, water, and SCA specifications.
 - If the engine has been in storage for less than 24 months and the engine has an extended life coolant with a rust inhibitor, drain the cooling system. Fill the cooling system with coolant. See the Coolant Recommendations and Specifications procedure in Section V of the corresponding owners and/or operation and maintenance manual for antifreeze, water, and SCA specifications.
- Adjust the engine brake (if applicable) and valve clearances. Reference the Overhead Set procedure in the corresponding base Troubleshooting and Repair Manual or Service Manual for the engine being serviced.
- Tighten the intake and exhaust manifold mounting capscrews.
- Prime the lubricating system.
- Reinstall any accessory drive belts that were removed.
- Replace all spark plugs. Reference the Spark Plugs procedure in the corresponding base Troubleshooting and Repair Manual or Service Manual for engine being serviced(if applicable).
- Make sure all fuel lines are securely tightened and all fuel shutoff valves are open prior to attempting to start the engine.
- Start the engine.
- Note that it might take multiple cranking attempts to start the engine. Do **not** crank the engine more than 30 seconds at a time as this might cause the starter to overheat and fail.
- Note that the engine might run rough until the fuel system is completely primed or until all residual fuel system preservative oil is completely flushed out of the fuel system (if the fuel has been treated with fuel system preservative oil).
- Install the exhaust aftertreatment components (if applicable).
- Force an active regeneration (if applicable).

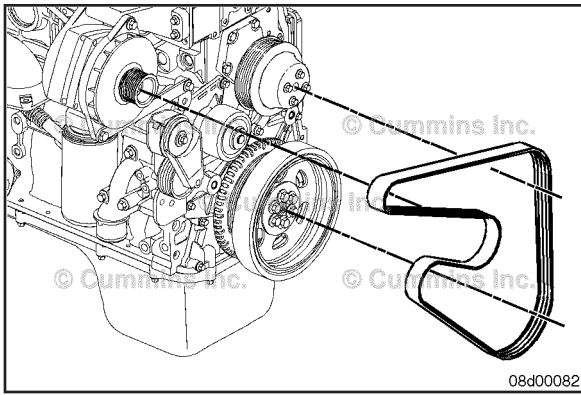

Engine Painting (000-007)

Preparatory Steps



Remove the cooling fan drive belt. Refer to Procedure 008-002

Cover the following parts of the engine:

- Exhaust and intake openings
- Electrical components
- Fuel inlet and drain connections.

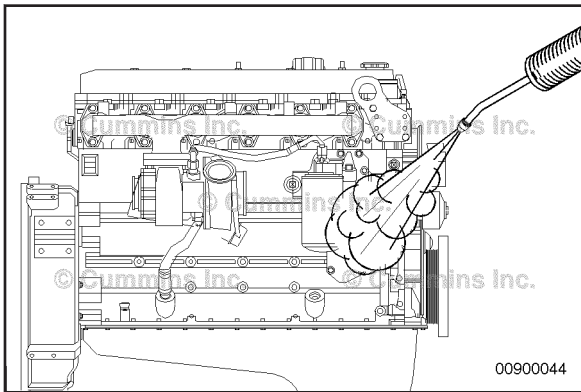

⚠ WARNING ⚠

When using a steam cleaner, wear safety glasses or a face shield, as well as protective clothing. Hot steam can cause serious personal injury.

⚠ WARNING ⚠

Compressed air used for cleaning should not exceed 207 kPa[30 psi]. Use only with protective clothing, goggles/shield, and gloves to reduce the possibility of personal injury.

⚠ CAUTION ⚠

To reduce the possibility of engine component damage, avoid prolonged, direct steam or water spray on electrical components.

Use steam to clean the engine and dry with compressed air.

NOTE: Make sure all engine surfaces are clean and dry before painting the engine.

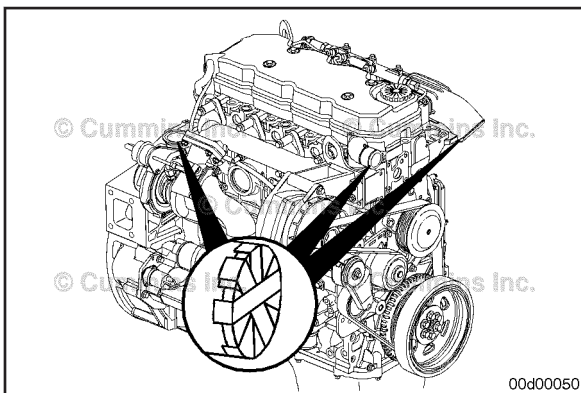

Protect the following components from paint:

- All dataplates (engine, fuel pump, etc.)
- Exhaust manifold
- Turbocharger turbine housing
- Flywheel
- Flywheel housing transmission mounting surface
- Electrical connections
- All decals
- All pulley belt surfaces
- Any exposed fittings, threads, and electrical wire terminals.

Paint the engine.

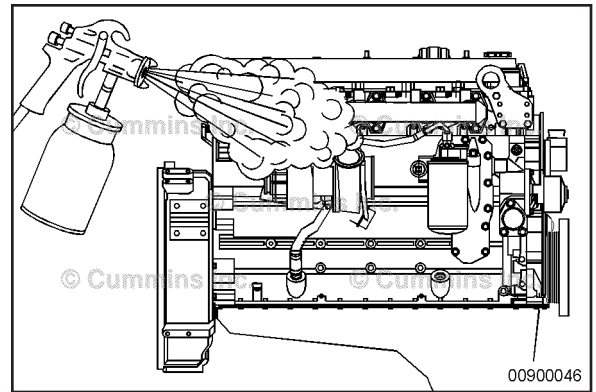

Engine Mounting Bolts (000-008) Inspect for Reuse

⚠ CAUTION ⚠

Damaged engine mounts and brackets can cause engine misalignment. Drivetrain component damage can result in excessive vibration complaints.

Inspect all rubber-cushioned mounts for cracks or damage.

Inspect all mounting brackets for cracks or damaged bolt holes.

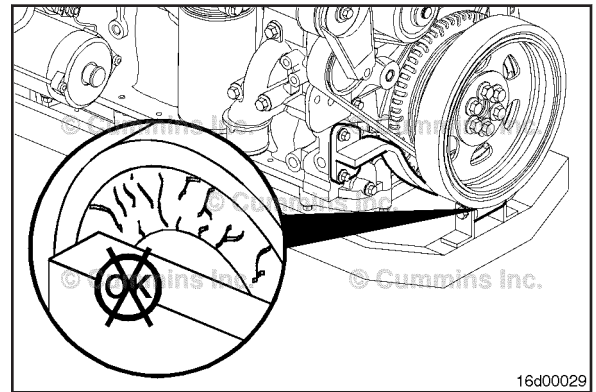

Engine Steam Cleaning (000-009) Clean

⚠ WARNING ⚠

When using a steam cleaner, wear safety glasses or a face shield, as well as protective clothing. Hot steam can cause serious personal injury.

Steam is the best method of cleaning a dirty engine or a piece of equipment. If steam is **not** available, use a solvent to wash the engine.

Protect all electrical components, openings, and wiring from the full force of the cleaner spray nozzle.

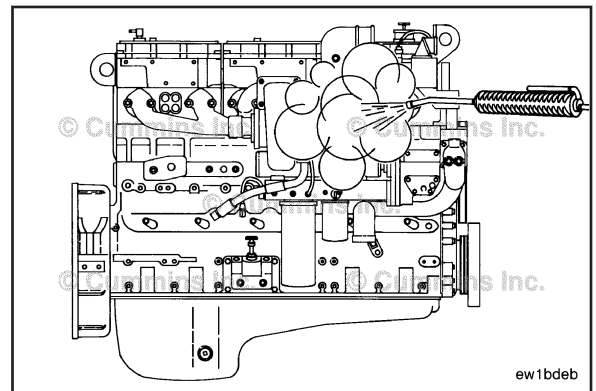

Section 1 - Cylinder Block - Group 01

Section Contents

	Page
Balancer	1-5
Assemble.....	1-6
Clean.....	1-6
Disassemble.....	1-5
Finishing Steps.....	1-8
Inspect for Reuse.....	1-6
Install.....	1-7
Preparatory Steps.....	1-5
Remove.....	1-5
Bearings, Connecting Rod	1-8
Clean and Inspect for Reuse.....	1-11
Finishing Steps.....	1-14
General Information.....	1-8
Install.....	1-13
Preparatory Steps.....	1-9
Remove.....	1-9
Bearings, Main	1-15
Clean and Inspect for Reuse.....	1-17
Finishing Steps.....	1-25
Initial Check.....	1-15
Install.....	1-20
Measure.....	1-19
Preparatory Steps.....	1-15
Remove.....	1-16
Block Stiffener Plate	1-197
Clean and Inspect for Reuse.....	1-198
Finishing Steps.....	1-199
Install.....	1-199
Preparatory Steps.....	1-197
Remove.....	1-198
Camshaft	1-25
Assemble.....	1-33
Clean and Inspect for Reuse.....	1-30
Disassemble.....	1-30
Finishing Steps.....	1-38
Initial Check.....	1-25
Install.....	1-34
Measure.....	1-32
Preparatory Steps.....	1-26
Remove.....	1-28
Camshaft Bushings	1-40
Finishing Steps.....	1-43
General Information.....	1-40
Initial Check.....	1-41
Inspect for Reuse.....	1-42
Install.....	1-42
Measure.....	1-43
Preparatory Steps.....	1-40
Remove.....	1-42
Camshaft Gear (Camshaft Installed)	1-44
Clean and Inspect for Reuse.....	1-46
Finishing Steps.....	1-49
General Information.....	1-44
Install.....	1-47
Measure.....	1-48
Preparatory Steps.....	1-45
Remove.....	1-45

Camshaft Gear (Camshaft Removed)	1-49
Clean and Inspect for Reuse.....	1-51
General Information.....	1-49
Install.....	1-52
Measure.....	1-52
Remove.....	1-50
Connecting Rod	1-54
Clean and Inspect for Reuse.....	1-56
Finishing Steps.....	1-60
General Information.....	1-54
Preparatory Steps.....	1-55
Crankshaft	1-60
Clean and Inspect for Reuse.....	1-63
Finishing Steps.....	1-75
General Information.....	1-60
Initial Check.....	1-68
Install.....	1-69
Measure.....	1-65
Preparatory Steps.....	1-61
Remove.....	1-62
Rotation Check.....	1-76
Crankshaft Gear, Front (Crankshaft Removed)	1-76
Clean and Inspect for Reuse.....	1-77
Install.....	1-78
Remove.....	1-76
Crankshaft Gear, Rear (Crankshaft Removed)	1-79
General Information.....	1-79
Crankshaft Gear, Rear (Crankshaft Removed)	1-80
General Information.....	1-80
Crankshaft Seal, Front	1-80
Clean and Inspect for Reuse.....	1-84
Finishing Steps.....	1-89
General Information.....	1-80
Install.....	1-86
Preparatory Steps.....	1-81
Remove.....	1-82
Crankshaft Seal, Rear	1-90
Clean and Inspect for Reuse.....	1-94
Finishing Steps.....	1-100
General Information.....	1-90
Install.....	1-95
Preparatory Steps.....	1-90
Remove.....	1-92
Crankshaft Speed Indicator Ring	1-195
Clean and Inspect for Reuse.....	1-196
Finishing Steps.....	1-197
General Information.....	1-195
Install.....	1-196
Measure.....	1-196
Preparatory Steps.....	1-195
Remove.....	1-195
Crankshaft Wear Sleeve, Front	1-101
Clean and Inspect for Reuse.....	1-103
Finishing Steps.....	1-107
General Information.....	1-101
Install.....	1-104
Preparatory Steps.....	1-101
Remove.....	1-103
Crankshaft Wear Sleeve, Rear	1-186
Clean and Inspect for Reuse.....	1-189
Finishing steps.....	1-193
General Information.....	1-186
Install.....	1-190
Preparatory steps.....	1-187

Remove.....	1-188
Cylinder Block	1-108
Clean and Inspect for Reuse.....	1-109
Finishing Steps.....	1-128
General Information.....	1-108
Initial Check.....	1-108
Measure.....	1-113
Preparatory Steps.....	1-109
Repair.....	1-118
ECM Mounting Plate	1-200
Assemble.....	1-202
Clean and Inspect for Reuse.....	1-201
Disassemble.....	1-201
Finishing Steps.....	1-202
General Information.....	1-200
Install.....	1-202
Preparatory Steps.....	1-200
Remove.....	1-201
Engine Dataplate	1-184
Clean and Inspect for Reuse.....	1-185
General Information.....	1-184
Install.....	1-185
Remove.....	1-184
Gear Cover, Front	1-128
Clean and Inspect for Reuse.....	1-131
Finishing Steps.....	1-137
Install.....	1-133
Preparatory Steps.....	1-128
Remove.....	1-130
Gear Housing, Front	1-139
Clean and Inspect for Reuse.....	1-142
Finishing Steps.....	1-146
Install.....	1-143
Preparatory Steps.....	1-139
Remove.....	1-141
Gear Housing, Rear	1-147
Clean and Inspect for Reuse.....	1-149
Finishing Steps.....	1-152
Install.....	1-149
Preparatory Steps.....	1-147
Remove.....	1-148
Piston	1-153
Clean and Inspect for Reuse.....	1-153
Failure Analysis Inspection.....	1-154
Piston and Connecting Rod Assembly	1-169
Assemble.....	1-175
Clean and Inspect for Reuse.....	1-174
Disassemble.....	1-173
Finishing Steps.....	1-183
General Information.....	1-169
Install.....	1-178
Preparatory Steps.....	1-170
Remove.....	1-171
Piston Cooling Nozzle	1-156
Clean and Inspect for Reuse.....	1-158
Finishing Steps.....	1-159
General Information.....	1-156
Install.....	1-159
Preparatory Steps.....	1-157
Remove.....	1-157
Piston Rings	1-160
Failure Analysis Inspection.....	1-160
Service Tools	1-1
Cylinder Block.....	1-1



Vibration Damper, Rubber	1-163
Clean and Inspect for Reuse.....	1-163
Finishing Steps.....	1-165
Install.....	1-165
Preparatory Steps.....	1-163
Remove.....	1-163
Vibration Damper, Viscous	1-166
Clean and Inspect for Reuse.....	1-166
Finishing Steps.....	1-168
Install.....	1-168
Preparatory Steps.....	1-166
Remove.....	1-166



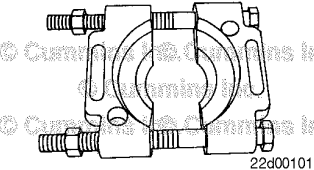
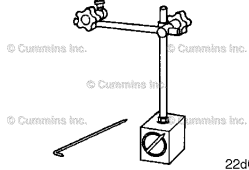
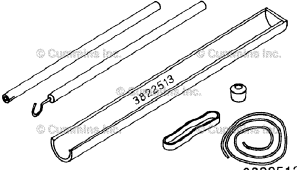
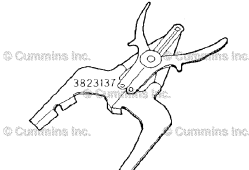
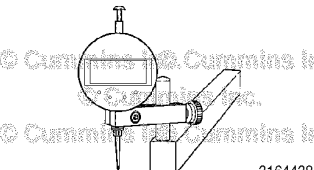

Service Tools

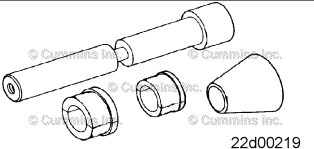
Cylinder Block

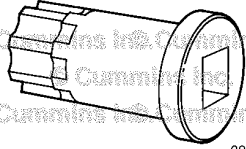
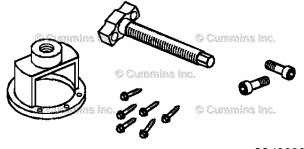
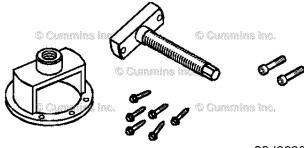
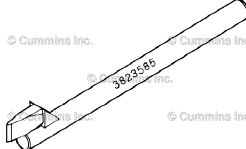
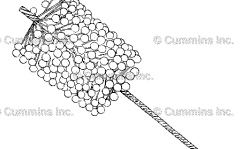
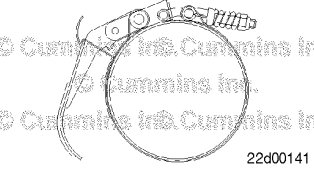
The following special tools are recommended to perform procedures in this section. The use of these tools is shown in the appropriate procedure. These tools can be purchased from a local Cummins® Authorized Repair Location.

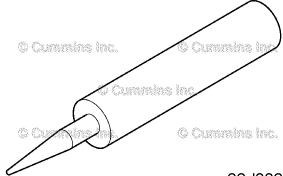
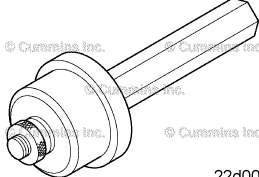
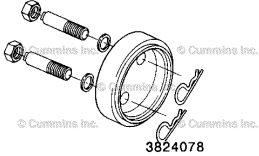
Tool No.	Tool Description	Tool Illustration
3822709	<p align="center">Thread Insert Kit</p> <p>Blind metric inserts can be used to repair several different size cylinder block threads.</p>	 <p align="center">22d00218</p>
3375326	<p align="center">Crankshaft Gear Remover</p> <p>Used to pull the crankshaft gear without heating or damaging the gear.</p>	 <p align="center">22d00101</p>
3377399	<p align="center">Magnetic Base Indicator Holder</p> <p>Used in conjunction with dial indicator, Part Number Metric — 3824564, or SAE — 4918289.</p>	 <p align="center">22d00102</p>
3822513	<p align="center">Tappet Removal Tool Kit</p> <p>Used to remove and install valve tappets.</p>	 <p align="center">3822513</p>
3823137	<p align="center">Piston Ring Expander</p> <p>Used to install piston rings onto pistons without damaging or distorting the rings.</p>	 <p align="center">3823137</p>
3164438	<p align="center">Depth Gauge Assembly</p> <p>Used to measure liner protrusion, cylinder block counterbore depths, and valve intrusion and/or protrusion. Equipped with digital, electronic, indicator.</p>	 <p align="center">3164438</p>

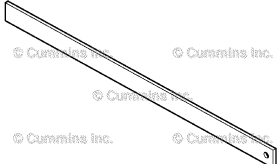
Tool No.	Tool Description	Tool Illustration
3165045	<p align="center">Camshaft Bushing Tool</p> <p>Used to replace camshaft bushings.</p>	 <p align="right">22d00219</p>
3164057	<p align="center">Capscrew Length Gauge</p> <p>Used to measure capscrew free length.</p>	 <p align="right">22d00085</p>
3824591	<p align="center">Barring Tool</p> <p>Used to engage the flywheel ring gear to rotate the crankshaft.</p>	 <p align="right">3824591</p>
3164659	<p align="center">Oil Seal Replacer (front)</p> <p>Used to remove/install the front crankshaft seal.</p>	 <p align="right">22d00086</p>
3164660	<p align="center">Oil Seal Replacer (rear)</p> <p>Used to remove/install the rear crankshaft seal, on engines equipped with unitized rear seal.</p>	 <p align="right">22d00087</p>
3823585	<p align="center">Gear Splitter</p> <p>Used to separate cast iron gears.</p>	 <p align="right">3823585</p>
3823612	<p align="center">Flexible Hone</p> <p>Used to deglaze the engine block cylinder walls.</p>	 <p align="right">22d00103</p>
3164330, 4918294	<p align="center">Piston Ring Compressor</p> <p>Used to install piston with rings into the cylinder bore. 3164330 - 102 mm bore engines. 4918294 - 107 mm bore engines.</p>	 <p align="right">22d00141</p>

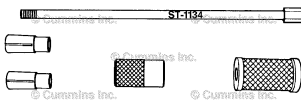
Tool No.	Tool Description	Tool Illustration
3164070	<p align="center">RTV Sealant</p> <p>Used to seal rear gear housing to block, front cover to block, and intake manifold to cylinder head joints.</p>	 <p align="right">22d00220</p>
3165035	<p align="center">Cam Bushing Driver</p> <p>Hand Held Driver can be used to replace front or rear bushings only.</p>	 <p align="right">22d00221</p>
3824078	<p align="center">Rear Wear Sleeve Installation Tool</p> <p>Used to install rear crankshaft oil seal wear sleeve. This tool can also be used to install standard lip type oil seal.</p>	 <p align="right">3824078</p>
3823818	<p align="center">Main Bearing Rollout Tool</p> <p>Used to remove and install main bearings with crankshaft installed.</p>	 <p align="right">3823818</p>
3163934, 3163935, 3163936, 3376488, 3164977	<p align="center">Assembly Guide Pins</p> <p>3163934 — M12 x 1.75, 3163935 — M10 x 1.25, 3163936 — M8 x 1.0, 3376488 — M10 x 1.5, 3164977 — M8 x 1.25</p>	 <p align="right">3822784</p>
4918219	<p align="center">Precision Straightedge</p> <p>Used to check cylinder blocks and cylinder heads for flatness.</p>	 <p align="right">22d00222</p>
3164067	<p align="center">RTV Sealant</p> <p>Used in most locations requiring RTV sealant.</p>	 <p align="right">22d00152</p>
3163720	<p align="center">Dowel Pin Extractor</p> <p>Use to remove solid locating pins from cylinder block. Kit includes SAE and Metric sizes.</p>	 <p align="right">ST-1134</p>

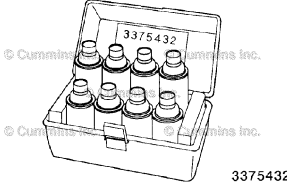
Tool No.	Tool Description	Tool Illustration
3375432	Crack Detection Kit Used to locate cracks in cylinder blocks, cylinder heads, as well as other engine components.	 <p>© Cummins Inc. 3375432</p> <p>© Cummins Inc. 3375432</p> <p>3375432</p>

Balancer (001-004)

Preparatory Steps

⚠️ WARNING ⚠️

Some state and federal agencies have determined that used engine oil can be carcinogenic and can cause reproductive toxicity. Avoid inhalation of vapors, ingestion, and prolonged contact with used engine oil. If not reused, dispose of in accordance with local environmental regulations.

⚠️ WARNING ⚠️

To reduce the possibility of personal injury, avoid direct contact of hot oil with your skin.

⚠️ WARNING ⚠️

This component weighs more than 23 kg [50 lb]. To reduce the possibility of personal injury, use a hoist or get assistance to lift the component.

- Drain the lubricating oil. Refer to Procedure 007-037 (Lubricating Oil System) in Section 7.
- Remove the lubricating oil pan. Refer to Procedure 007-025 (Lubricating Oil Pan) in Section 7.

Remove

⚠️ WARNING ⚠️

This component weighs more than 23 kg [50 lb]. To reduce the possibility of personal injury, use a hoist or get assistance to lift the component.

Rotate the crankshaft until the engine is positioned at number one piston top dead center (TDC).

Remove the eight (8) balancer assembly fastening capscrews.

Remove the balancer assembly.

Disassemble

Place the balancer assembly on a work bench.

Remove the capscrews from the cover plate.

Remove the cover plate.

Remove the balancer assembly shaft assemblies.

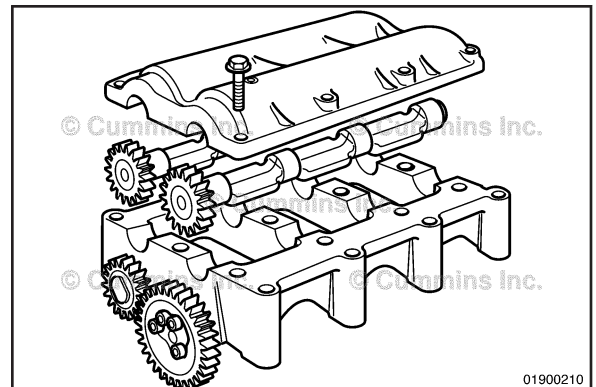
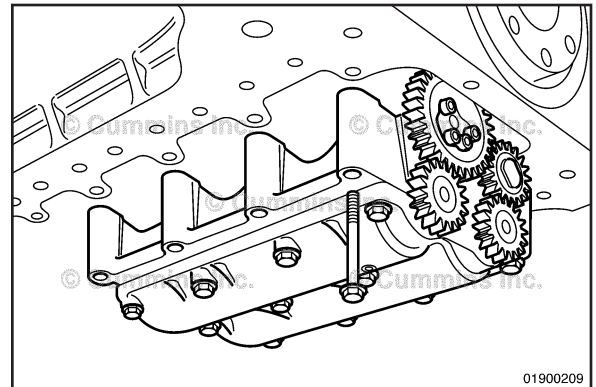
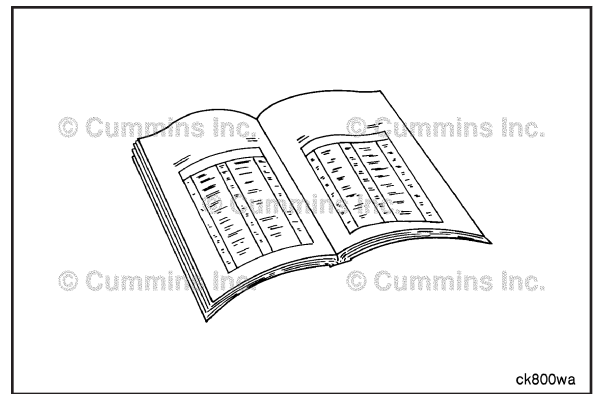

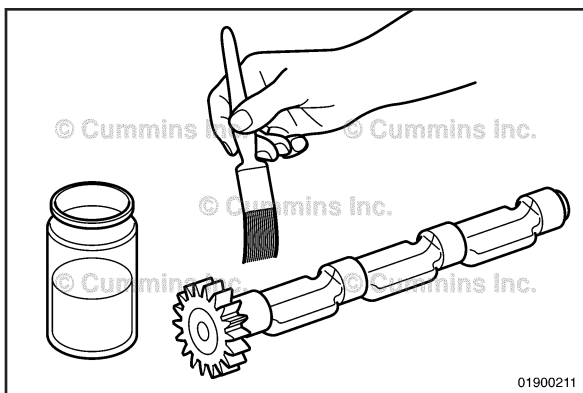

Clean

⚠ WARNING ⚠

When using solvents, acids, or alkaline materials for cleaning, follow the manufacturer's recommendations for use. Wear goggles and protective clothing to reduce the possibility of personal injury.

⚠ WARNING ⚠

Wear appropriate eye and face protection when using compressed air. Flying debris and dirt can cause bodily injury.

Clean the shaft assemblies with solvent and dry with compressed air.

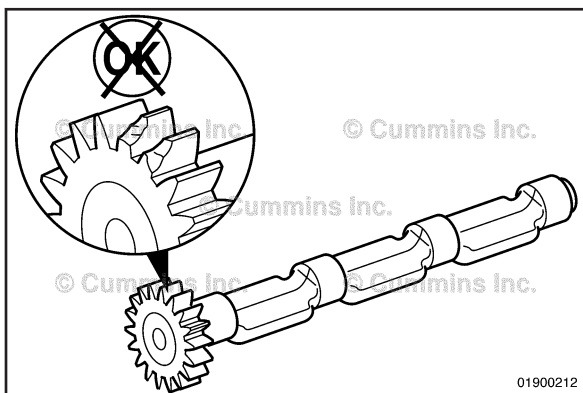

Inspect for Reuse

Inspect the balancer shaft drive gears for pitting or missing teeth.

Replace the gears if pitting is noted or if teeth are missing.

Inspect the balancer shaft bushings for excessive wear. Replace the bushings if excessive wear is evident.

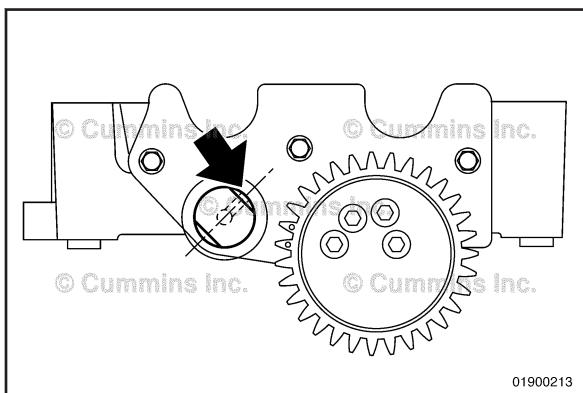

If the idler shaft is removed and inspected, it **must** be installed with the oil feed hole angled to the closest point of the thrust bearing plate oil passage.

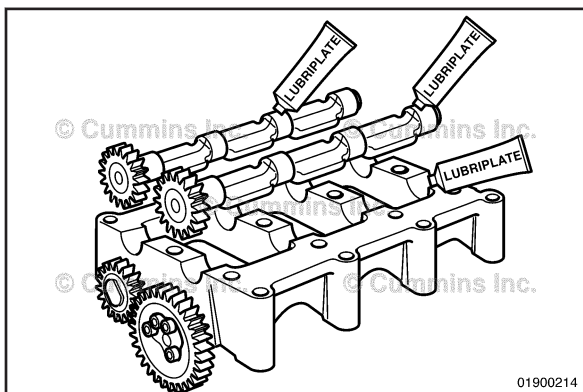

Assemble

Apply Lubriplate™ 105 to the balancer housing and shaft journals.

Install the shaft assemblies and align the timing marks.

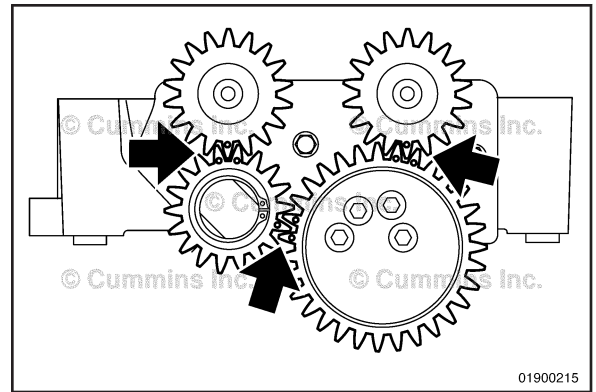

Assemble the balancer assembly cover and capscrews.

Torque Value: 32 N•m [24 ft-lb]

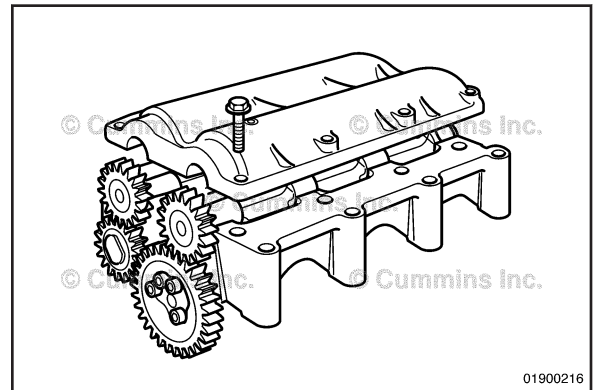

Align the drive and driven gear timing marks.

Lock the shafts by installing a M8 x 125 mm capscrew into the left side of the cover plate. Hand tighten the capscrew.

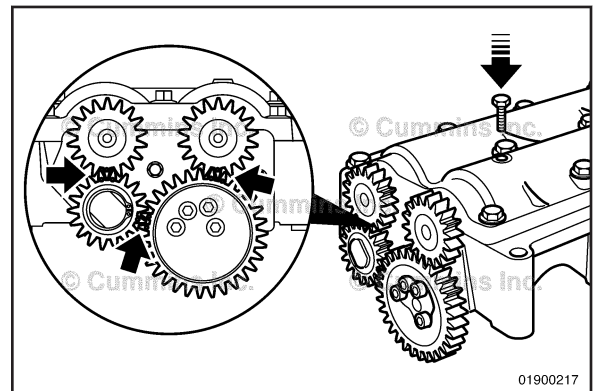

Install

NOTE: The engine must be on compression stroke, number one cylinder. Refer to Procedure 003-004 (Overhead Set) in Section 3.

With the number one piston at top dead center (TDC), align the balancer assembly with the block sump face dowels. Mesh the timing mark of the balancer shaft drive gear with the crankshaft gear timing marks.

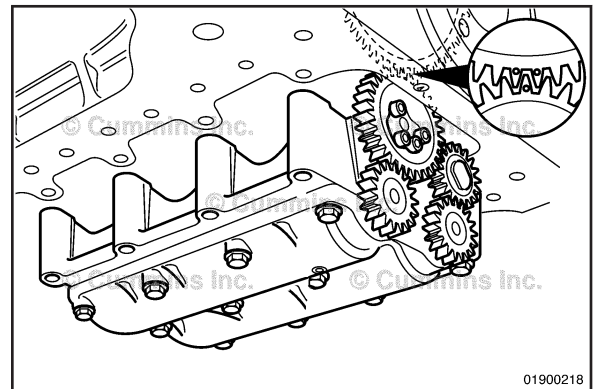

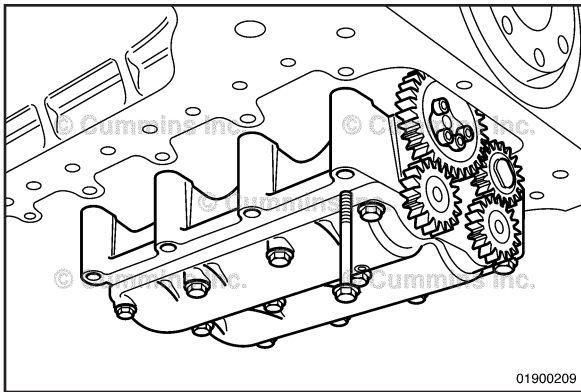

Install the capscrews.

Torque Value: 48 N•m [35 ft-lb]

⚠CAUTION⚠

Remove the locking screw from the balancer assembly cover plate.

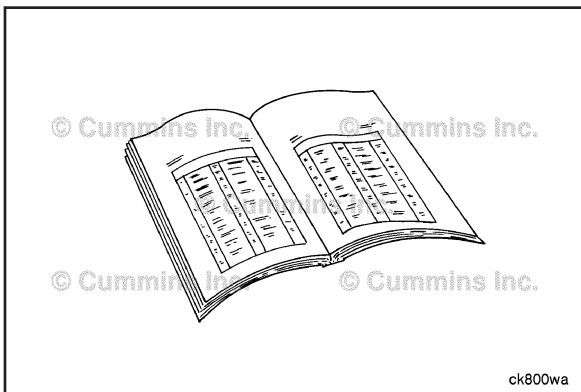

Finishing Steps

⚠WARNING⚠

This component weighs more than 23 kg [50 lb]. To reduce the possibility of personal injury, use a hoist or get assistance to lift the component.

- Install the lubricating oil pan. Refer to Procedure 007-025 (Lubricating Oil Pan) in Section 7.
- Fill the engine with lubricating oil. Refer to Procedure 007-037 (Lubricating Oil System) in Section 7.
- Operate the engine and check for leaks.

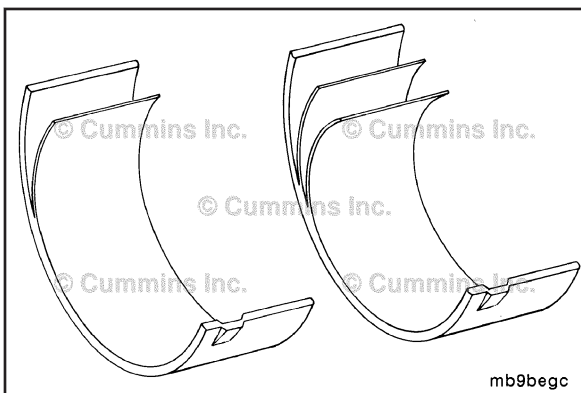

Bearings, Connecting Rod (001-005)

General Information

In general, various types of connecting rod bearings have been used in B series engines:

- Bi-metal overlays
- Tri-metal overlays
- Narrowed bearings (for some Naturally Aspirated engines).

Reference the appropriate Part Information resources when replacing the connecting rod bearings, so the correct connecting rod bearings are installed.

Preparatory Steps

⚠️ WARNING ⚠️

Batteries can emit explosive gases. To reduce the possibility of personal injury, always ventilate the compartment before servicing the batteries. To reduce the possibility of arcing, remove the negative (-) battery cable first and attach the negative (-) battery cable last.

⚠️ WARNING ⚠️

To reduce the possibility of personal injury, avoid direct contact of hot oil with your skin.

⚠️ WARNING ⚠️

Some state and federal agencies have determined that used engine oil can be carcinogenic and cause reproductive toxicity. Avoid inhalation of vapors, ingestion, and prolonged contact with used engine oil. If not reused, dispose of in accordance with local environmental regulations.

- Disconnect the battery cables. Refer to Procedure 013-009
- Drain the lubricating oil. Refer to Procedure 007-037
- Remove the oil pan and oil pan gasket. Refer to Procedure 007-025
- Remove the lubricating oil suction tube. Refer to Procedure 007-035
- If equipped, remove the block stiffener plate. Refer to Procedure 001-089

Remove

⚠️ CAUTION ⚠️

If equipped with fracture split connecting rods, be careful not to damage the fractured split surface on the connecting rod or connecting rod cap while the connecting rod cap is removed. If the fractured split surface is damaged, the connecting rod and connecting rod cap must be replaced to help reduce the possibility of engine damage.

NOTE: The cylinder head does **not** need to be removed if the connecting rod bearings are being inspected or replaced.

Use the barring tool, Part Number 3824591, to bar the engine over to bottom dead center of the connecting rod bearing to be removed.

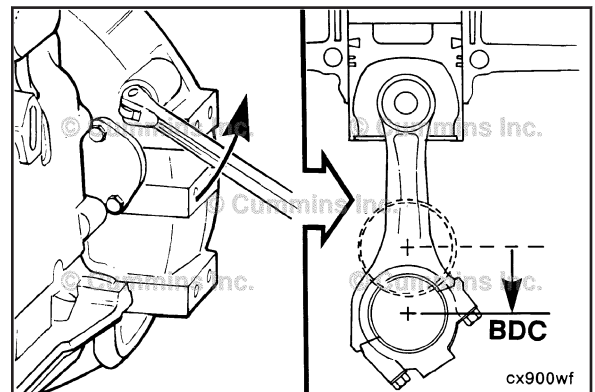
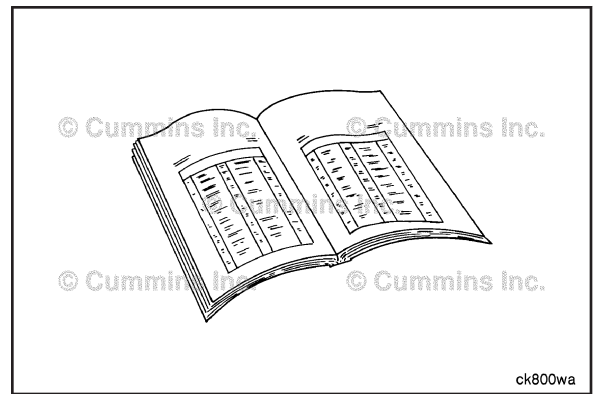

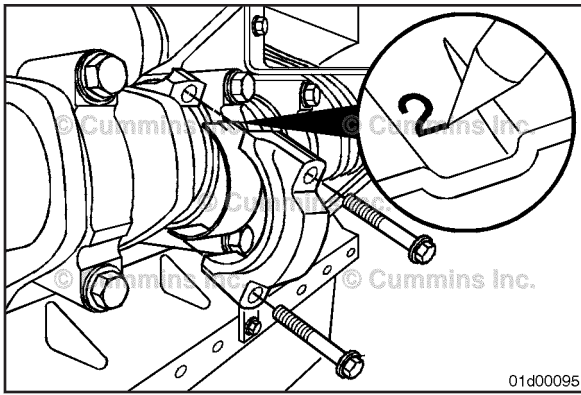

Mark each connecting rod and cap to identify cylinder location.

Remove and install **only** one connecting rod cap at a time to avoid mismatching connecting rods and rod caps.

Remove the connecting rod bolts and connecting rod cap.

Remove the lower end bearing.

Mark the cylinder number and the letter "L" (lower) on the flat surface of the bearing tang.

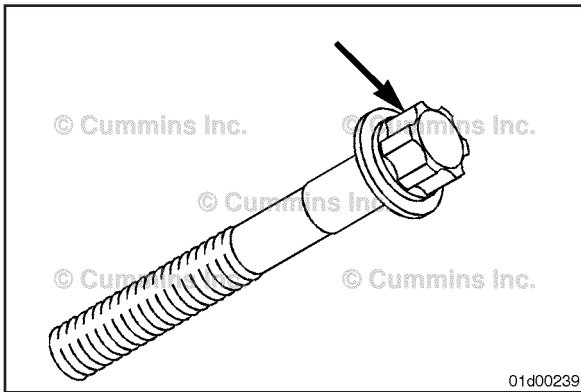

Some engines are equipped with external Torx® head connecting rod bolts.

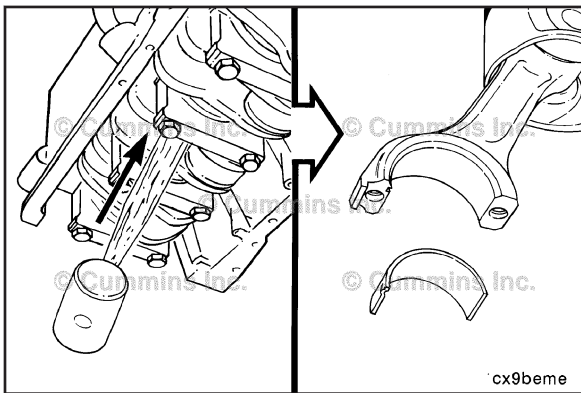

⚠ CAUTION ⚠

Do not damage the J-jet piston cooling nozzles when sliding the connecting rod into the cylinder away from the crankshaft. Engine damage can result.

NOTE: Slight bending of the j-jet piston cooling nozzles can result in severe engine damage. Replace piston cooling nozzles if any are bent or damaged during assembly or disassembly.

If equipped, remove the j-jet piston cooling nozzle for each cylinder for which the connecting rod bearings will be removed. Refer to Procedure 001-046

Push the connecting rod into the cylinder, away from the crankshaft, to allow the upper bearing shell to be removed.

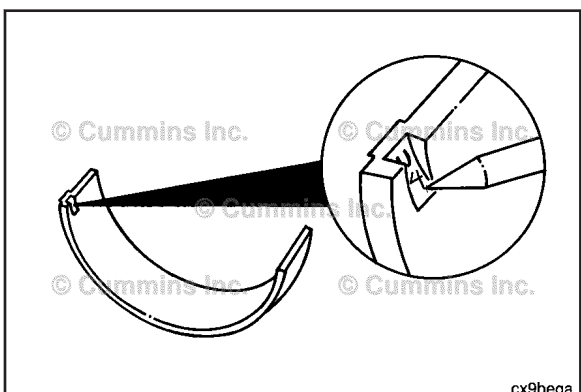

Mark the connecting rod bearings for position and cylinder number as they are removed.

Example: U1 - upper rod bearing for cylinder number 1.

Clean and Inspect for Reuse

⚠ WARNING ⚠

Wear appropriate eye and face protection when using compressed air. Flying debris and dirt can cause personal injury.

Clean the bearing and connecting rod caps.

Dry with compressed air.

Inspect the connecting rod caps, connecting rod bearing saddles, and capscrews for nicks, cracks, burrs, scratches, or fretting.

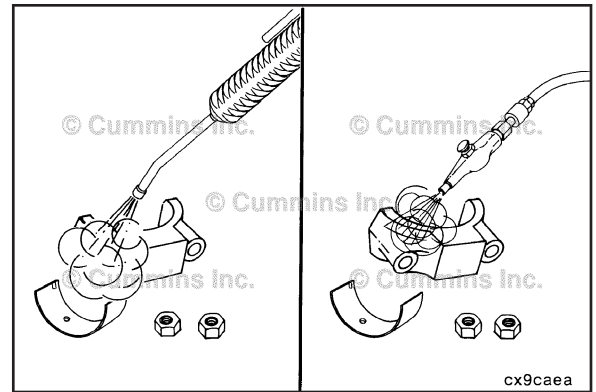

Inspect the bearings for damage.

Replace any bearings with the following damage.

- Pitting
- Flaking
- Corrosion
- Lock tang damage
- Scratches.

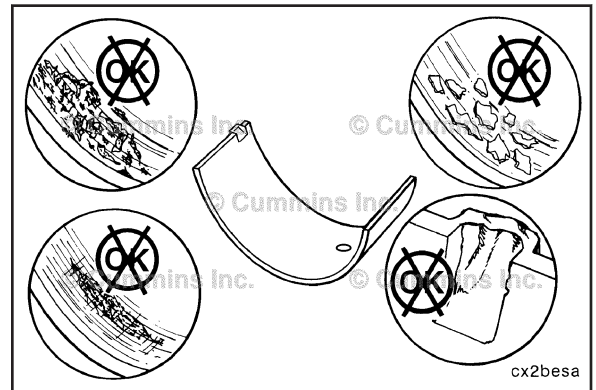

Inspect the bearing shell seating surface for nicks or burrs.

If nicks or burrs can **not** be removed with an abrasive pad, Part Number 3823258 or equivalent, the bearings **must** be replaced.

If bearings are damaged, they **must** be replaced as a set.

For more detailed information of bearing damage, see Analysis and Prevention of Bearing Failures, Bulletin 3810387.

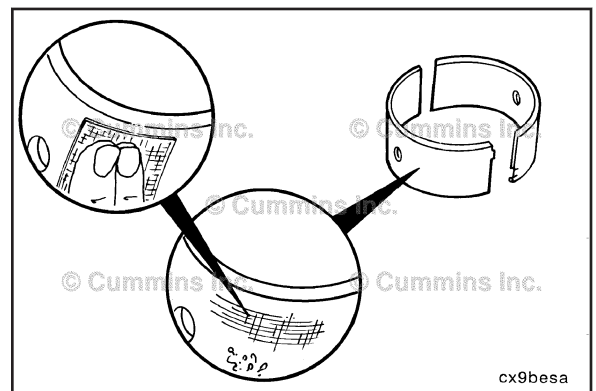

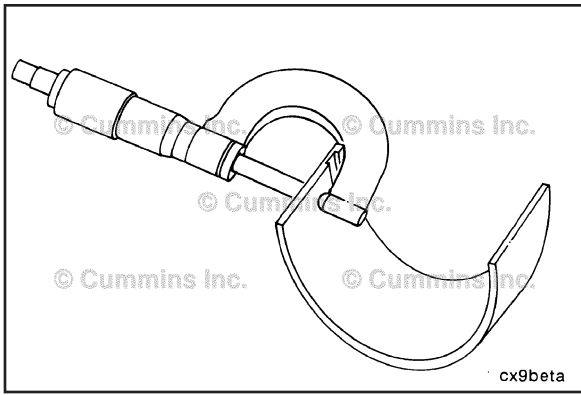

Measure the rod bearing shell thickness with an outside micrometer that has a ball tip.

Connecting Rod Bearing Dimensions			
	mm		in
Standard	1.955	MIN	0.0770
	1.968	MAX	0.0775
0.25 mm [0.010 in]	2.080	MIN	0.0819
	2.093	MAX	0.0824
0.50 mm [0.020 in]	2.205	MIN	0.0868
	2.218	MAX	0.0873
0.75 mm [0.030 in]	2.330	MIN	0.0917
	2.343	MAX	0.0922
1.00 mm [0.040 in]	2.455	MIN	0.0967
	2.468	MAX	0.0972

Discard a bearing shell if its thickness is below the minimum specification.

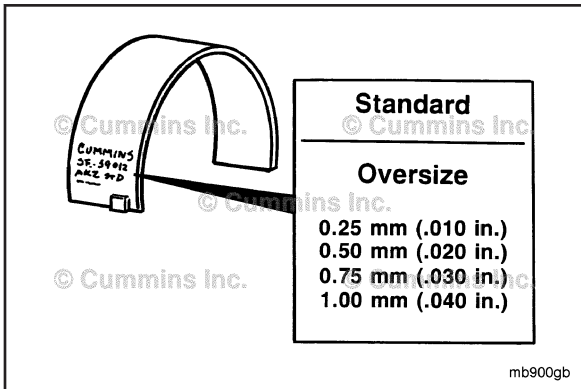

Connecting rod bearings are identified with a part number and size stamped on the back side.



Determine the size of the removed rod bearing and obtain a set of the same size.

Oversize service rod bearings are available for use with crankshafts that have been machined undersized. See the appropriate parts catalog.

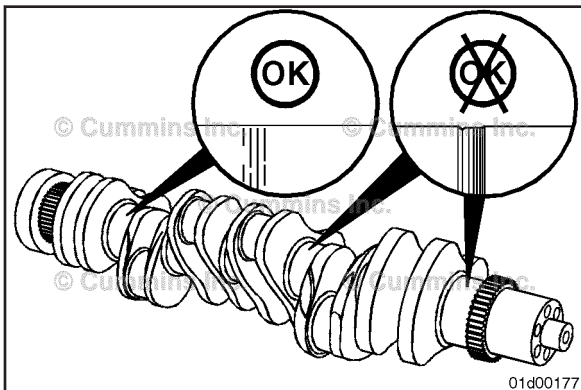

Check the rod bearing journals for damage or excessive wear. Minor scratches are acceptable.

Install

Used connecting rod bearings **must** be installed in their original locations.

To reduce the possibility of engine damage, make sure the back side of the bearing and connecting rod surface that contacts the bearing is clean and dry.

Install the upper bearings in the connecting rod. Make sure the tang is aligned.

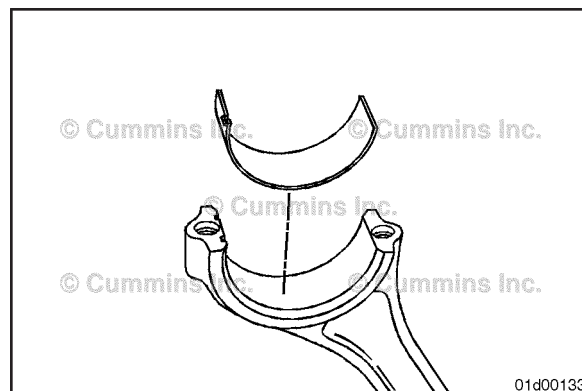

Install the lower bearings in the connecting rod caps. Make sure the tang is aligned.

NOTE: For engines equipped with fracture split connecting rods, the upper and lower connecting rod bearings are **not** interchangeable.

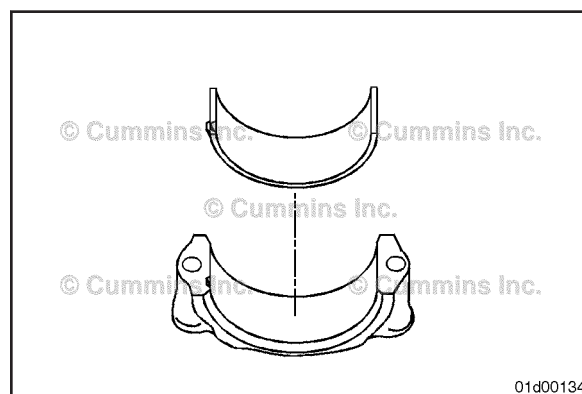

NOTE: For engines equipped with fracture split connecting rods, the fracture split surface on the connecting rod and connecting rod cap **must** be kept dry and clean to ensure proper mating of the two surfaces.

Lubricate the bearing surfaces with Assembly Lube, Part Number 3163087 or equivalent.

Lubricate the connecting rod bolt threads and under the heads with clean 15W-40 oil.

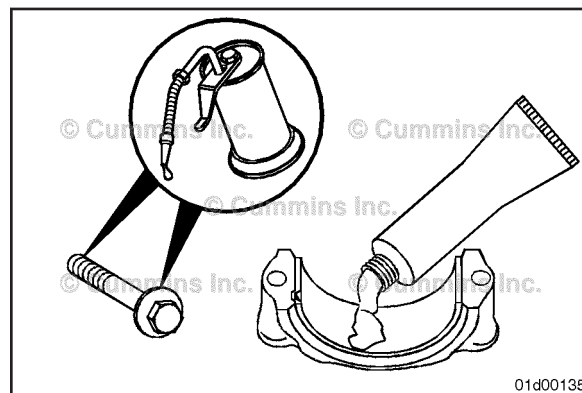

When installing the connecting rod cap, the numbers stamped on the connecting rod cap and connecting rod **must** match and be on the same side of the connecting rod, to prevent engine damage during operation.

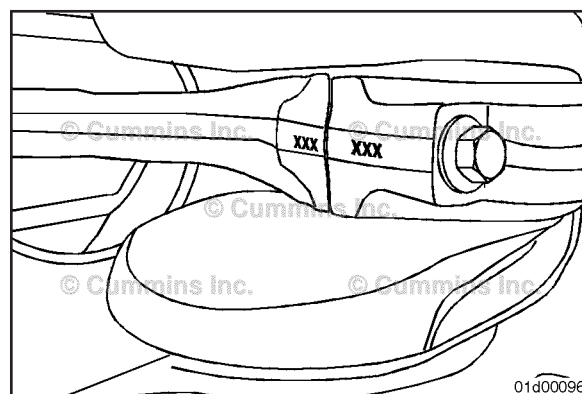

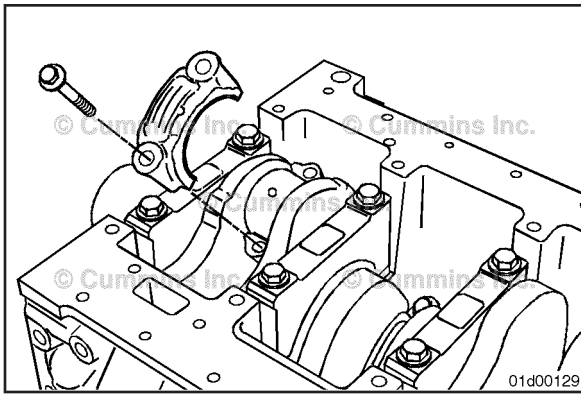

Install the connecting rod cap on the corresponding connecting rod.

Install and hand-tighten the connecting rod capscrews.

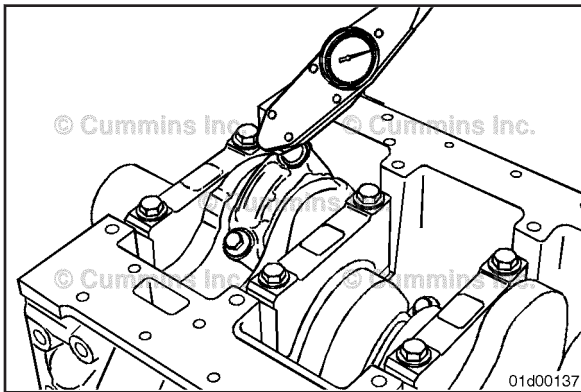

Tighten the connecting rod capscrews.

Alternately tighten the two capscrews.

Torque Value:

Step 1	30 N•m	[22 ft-lb]
Step 2	60 N•m	[44 ft-lb]
Step 3	Rotate 60 degrees.	

After tightening the capscrews for each connecting rod, rotate the crankshaft 360 degrees to make sure the crankshaft rotates freely.

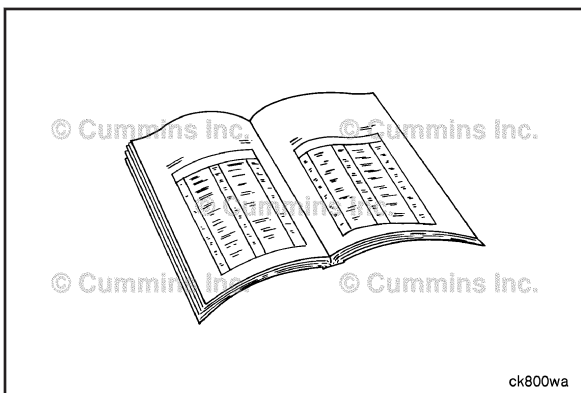

Finishing Steps

▲ WARNING ▲



Batteries can emit explosive gases. To reduce the possibility of personal injury, always ventilate the compartment before servicing the batteries. To reduce the possibility of arcing, remove the negative (-) battery cable first and attach the negative (-) battery cable last.

- If equipped and previously removed, install the j-jet piston cooling nozzles. Refer to Procedure 001-089
- If equipped, install the block stiffener plate. Refer to Procedure 001-089
- Install the lubricating oil suction tube. Refer to Procedure 007-035
- Install the oil pan and oil pan gasket. Refer to Procedure 007-025
- Fill with clean lubricating oil. Refer to Procedure 007-037
- Connect the battery cables. Refer to Procedure 013-009
- Operate the engine, check for leaks and proper oil pressure.

Bearings, Main (001-006)

Preparatory Steps

⚠️ WARNING ⚠️

Batteries can emit explosive gases. To reduce the possibility of personal injury, always ventilate the compartment before servicing the batteries. To reduce the possibility of arcing, remove the negative (-) battery cable first and attach the negative (-) battery cable last.

Disconnect the batteries.

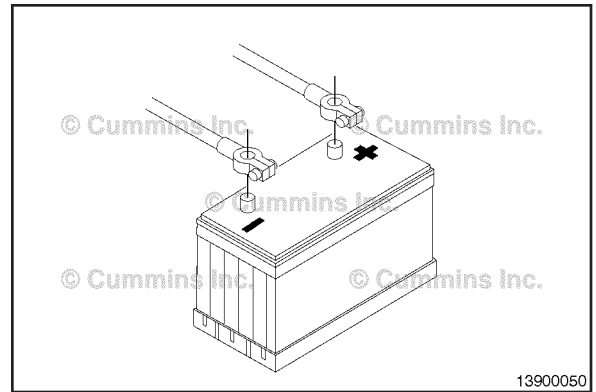

⚠️ WARNING ⚠️

Some state and federal agencies have determined that used engine oil can be carcinogenic and can cause reproductive toxicity. Avoid inhalation of vapors, ingestion, and prolonged contact with used engine oil. If not reused, dispose of in accordance with local environmental regulations.

⚠️ WARNING ⚠️

To reduce the possibility of personal injury, avoid direct contact of hot oil with your skin.

Drain the lubricating oil. Refer to Procedure 007-037 (Lubricating Oil System) in Section 7.

Remove the lubricating oil pan and gasket. Refer to Procedure 007-025 (Lubricating Oil Pan) in Section 7.

Remove the lubricating oil suction tube. Refer to Procedure 007-035 (Lubricating Oil Suction Tube (Block-Mounted)) in Section 7.

Remove the block stiffener plate. Refer to Procedure 001-089 (Block Stiffener Plate) in Section 1.

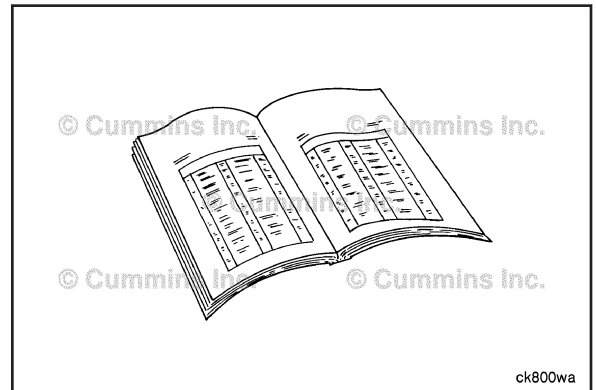

Initial Check

NOTE: The dimensions of the thrust bearing and crankshaft journal determine end play.

Measure the crankshaft end play using dial indicator, Part Number 3824564 and magnetic base, Part Number 3377399.

Crankshaft End Play

mm		in
0.102	MIN	0.004
0.432	MAX	0.017

If the crankshaft end play is **not** within specification, make sure to inspect the crankshaft and thrust bearing surfaces for damage.

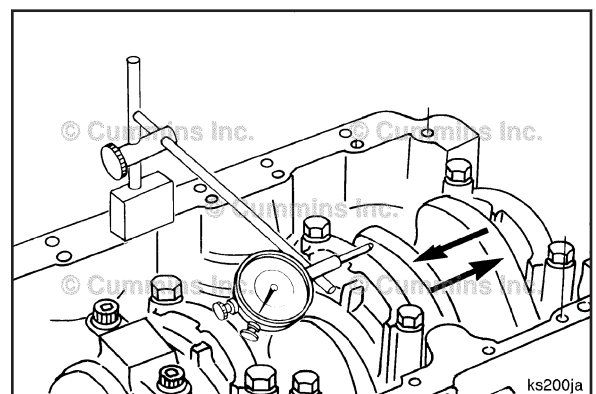

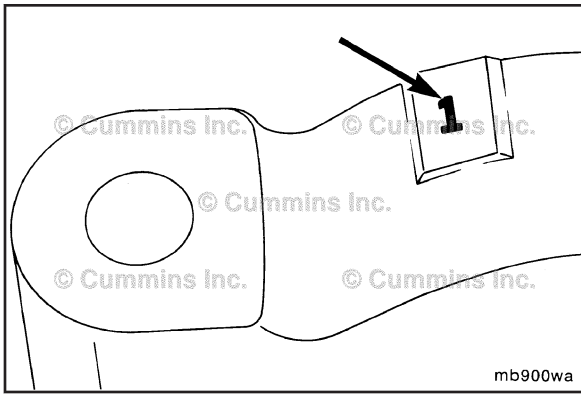

Remove

Before removing the main bearing caps, make certain that the caps are clearly marked for their location on the lubricating oil cooler side of the main bearing cap and cylinder block.

The number one cap is at the front of the engine.

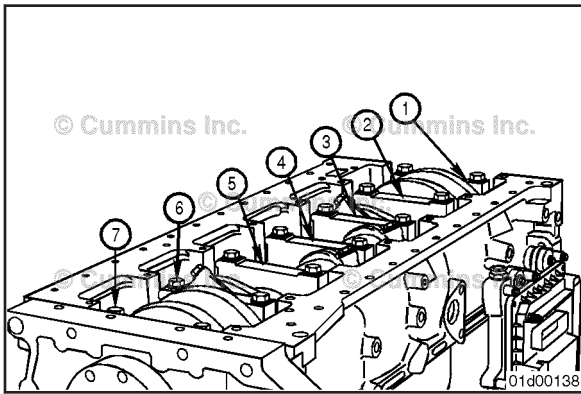

NOTE: When replacing bearings in chassis: For four cylinder engines, replace number 2 through 4 while the number 1 and number 5 caps support the crankshaft. After replacing number 2 through number 4, replace number 1 and number 5. For six cylinder engines, replace number 2 through 6 while the number 1 and number 7 caps support the crankshaft. After replacing number 2 through number 6, replace number 1 and number 7.

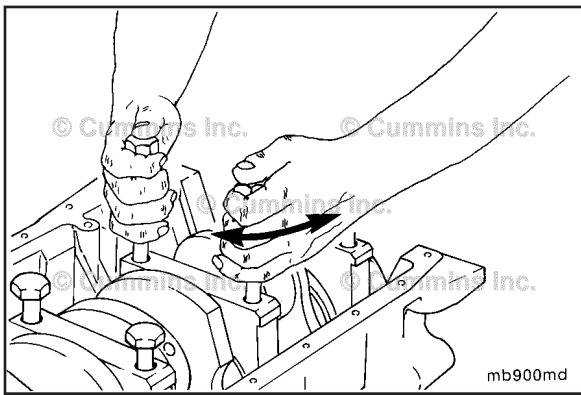

⚠ CAUTION ⚠

Do not pry on the main bearing caps to free them from the cylinder block. Damage to the main bearing caps and cylinder block can result.

Loosen the main bearing capscrews completely, but do **not** remove.

Use two of the main bearing cap bolts to "wiggle" the main bearing cap loose, being careful **not** to damage the bolt threads.

Remove the main bearing cap.

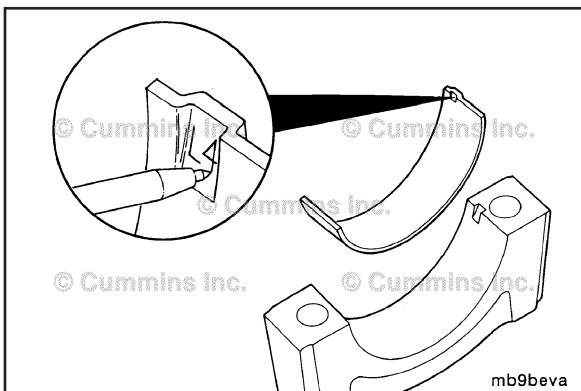

Mark the main bearings for position and number as they are removed.

Use an awl to mark the bearing's position in the tang area.

NOTE: Marking the bearing's position is for future identification or possible failure analysis.

Follow this step to remove the upper main bearings, except for number 1 front main bearing.

To remove the upper main bearing, install the main bearing replacer, Part Number 3823818, in the oil hole of the crankshaft main bearing journal.

Use a barring tool, Part Number 3824591, to rotate the crankshaft so that the replacer contacts the upper main bearing on the side opposite the tang.

Continue to rotate the crankshaft in the direction that will remove the tang side (1) of the upper main bearing first.

Remove the bearing.

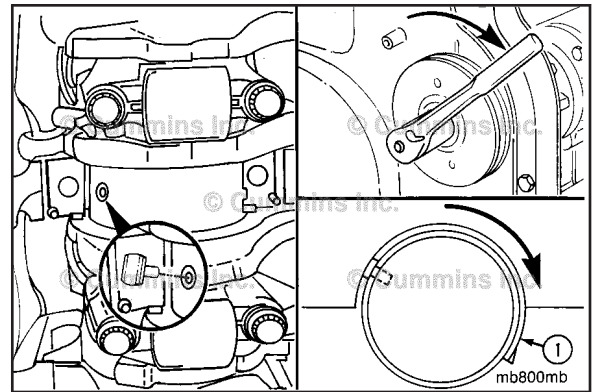

⚠ CAUTION ⚠

Use care so the screwdriver does not damage the crankshaft or cylinder block.

NOTE: The front main bearing, number 1, does **not** have a hole in the journal, so the tool can **not** be used to replace the bearing.

Use a flat blade screwdriver to gently bump the end of the bearing to loosen it from the cylinder block. Then, use finger pressure against the main bearing shell and rotate the crankshaft to roll the main bearing out.

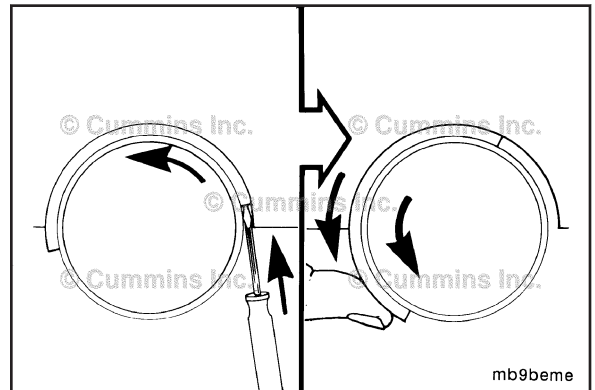

Clean and Inspect for Reuse

⚠ WARNING ⚠

When using a steam cleaner, wear safety glasses or a face shield, as well as protective clothing. Hot steam can cause serious personal injury.

⚠ WARNING ⚠

Wear appropriate eye and face protection when using compressed air. Flying debris and dirt can cause personal injury.

Steam-clean or use hot, soapy water to clean the main bearing caps.

Dry with compressed air.

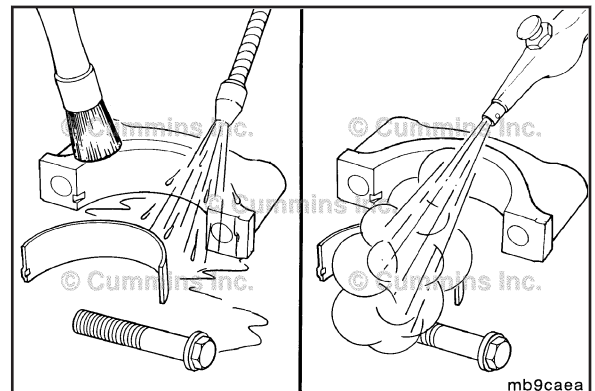

Inspect all main bearing caps, capscrews and thrust bearings for deep scoring, overheating, etc.

Replace any damaged components. If the main bearing cap is damaged, the block **must** be replaced.

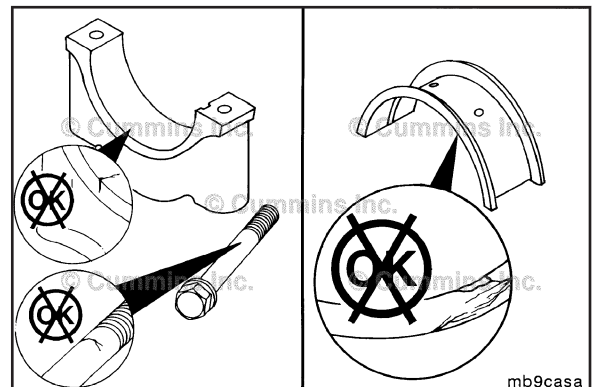

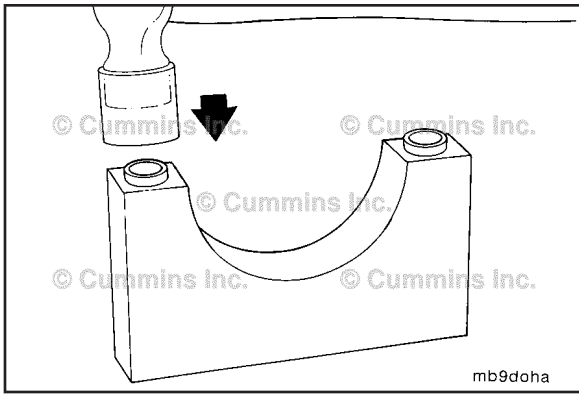

Check the main bearing caps to make sure the ring dowels are installed.

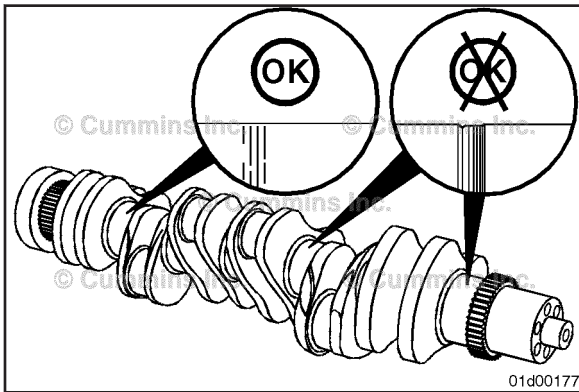

Check the crankshaft main bearing journals for damage or excessive wear. Minor scratches are acceptable.

If crankshaft end play measured during the initial check was found to be out of specification, make sure to check the crankshaft thrust surface for excessive wear or damage. Minor scratches are acceptable.

Four cylinder engines - The number 4 main bearing journal.

Six cylinder engines - The number 6 main bearing journal.

If damage is found, the crankshaft will need to be removed. Refer to Procedure 001-016 (Crankshaft) in Section 1.

Also check the thrust bearing surfaces for excessive wear. Replace the thrust bearing(s) if excessive wear is found

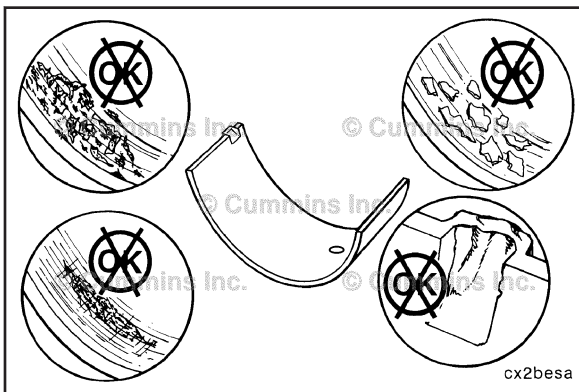

Inspect the bearings for damage.

Replace any bearings with the following damage:

- Pitting
- Flaking
- Corrosion
- Lock tang damage
- Scratches.

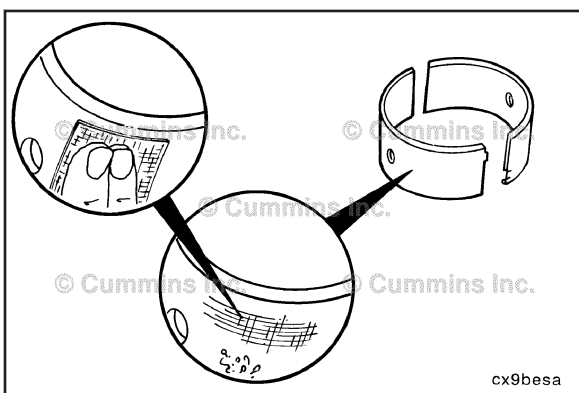

Inspect the bearing shell seating surfaces for nicks or burrs. If nicks or burrs can **not** be removed with an abrasive pad, Part Number 3823258 or equivalent, the bearings **must** be replaced.

NOTE: If bearings are damaged they **must** be replaced as a set.

NOTE: For more detailed information on bearing damage, refer to Analysis and Prevention of Bearing Failures, Bulletin 3810387.

Measure

Measure the main bearing shell thickness with an outside micrometer that has a ball tip.

Main Bearing Dimensions

	mm		in
Standard	2.456	MIN	0.0967
	2.464	MAX	0.097
Oversize 0.25 mm [0.010 in]	2.706	MIN	0.1067
	2.714	MAX	0.117
Oversize 0.50 mm [0.020 in]	2.956	MIN	0.1167
	2.964	MAX	0.117
Oversize 0.75 mm [0.030 in]	3.206	MIN	0.1267
	3.214	MAX	0.127
Oversize 1.00 mm [0.040 in]	3.456	MIN	0.1367
	3.464	MAX	0.137

Discard a bearing shell if its thickness is below the minimum specifications.

NOTE: Main bearings are identified with a part number and size stamped on the back side.

If replacing the bearings, determine the size of the removed main bearings and obtain a set of the same size.

Oversize service main bearings are available for use with crankshafts that have been machined undersize. See the appropriate parts catalog.

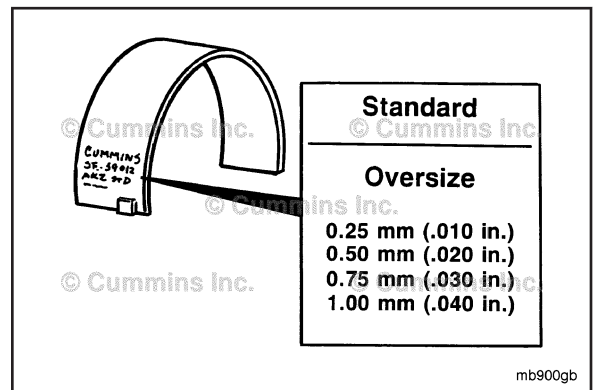
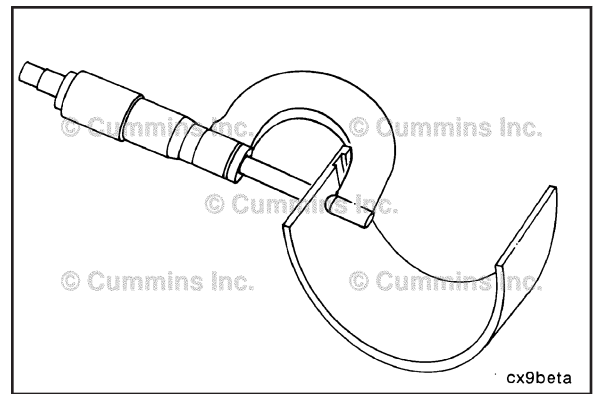

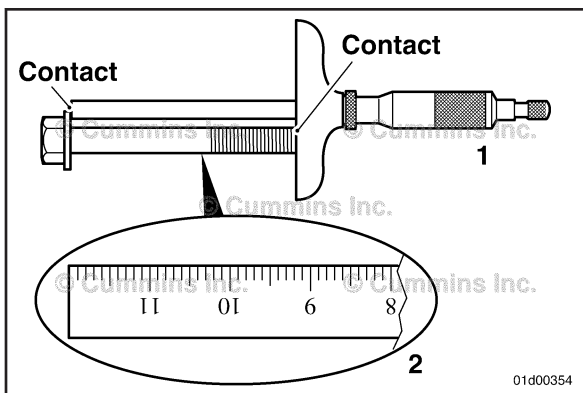

⚠ CAUTION ⚠

This step must be completed on 4.5L and 6.7L engine. Failure to check the main bearing capscrew against reuse guidelines can result in severe engine damage.

Main Bearing Capscrew Reuse Measurement

To check if a main bearing capscrew can be reused, the length **must** be measured by performing the following:

For each main bearing capscrew that has been removed, measure the length from underneath the head of the capscrew to the tip of the capscrew, as illustrated, using one of two methods.

- 1 A depth micrometer (preferred method for accuracy)
- 2 A machinist's rule.

If the measurement is above the maximum specification, the main bearing capscrew **must** be replaced.

Main Bearing Underhead Capscrew Length

mm		in
120.00	MAX	4.724

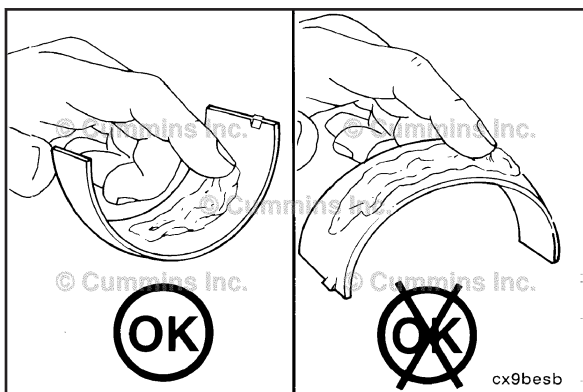

Install

⚠ CAUTION ⚠

Do not lubricate the side that is against the cylinder block.

Upper Main Bearing

NOTE: Make sure the main bearing being installed is the same size as the main bearing removed, if the crankshaft has not been machined. The size is engraved on the back of the main bearing.

NOTE: Install the upper main bearing cap after each upper main bearing is installed to keep the main bearing in place while the other upper main bearings are installed.

Apply assembly lube, Part Number 3163086, to the upper main bearings.

NOTE: The crankshaft thrust bearing **must** be installed in the: Four cylinder engines - The number 4 main bearing position. Six cylinder engines - The number 6 main bearing position.

NOTE: Some engines use a thrust bearing for the upper and lower main bearing (360 degree), while other engines only have a thrust bearing for the upper main bearing (180 degree). **Always** replace like for like.

NOTE: The upper and lower main bearing shells are not interchangeable. The backs of the main bearings are marked with the proper orientation.

Install the upper main bearings.

Insert the side of the main bearing opposite the tang first in between the crankshaft journal and block. Install the bearing as far as possible by hand.

When installing the thrust bearing, it may be necessary to push the crankshaft to the front or rear of the cylinder block.

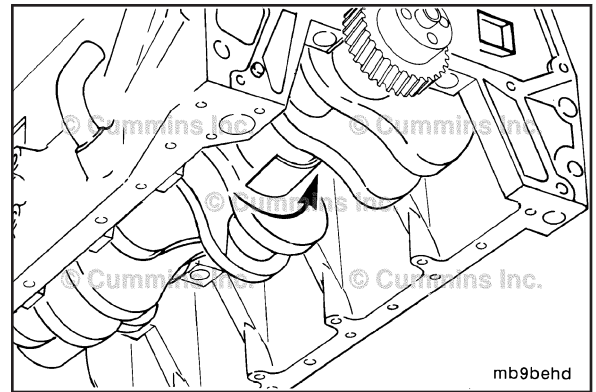

⚠ CAUTION ⚠

Make sure the pin does not slide under the bearing.

Follow this step to finish installing the upper main bearings, except for number 1 front main bearing.

Using the main bearing replacer, Part Number 3823818, finish installing the main bearing. Rotate the crankshaft, using the barring tool, Part Number 3824591.

Make sure the tang (1) on the main bearing is located in the notch (2) of the cylinder block. Finish pushing the main bearing into position.

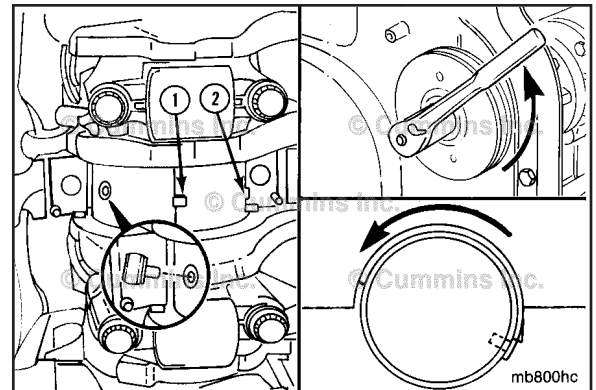

⚠ CAUTION ⚠

Use care so the screwdriver does not damage the crankshaft or cylinder block.

NOTE: The front main, number 1, does **not** have a hole in the journal so the pin can **not** be used to replace the bearing.

Install the number 1 main bearing.

Insert the side of the main bearing opposite the tang first and install as far as possible by hand.

Use a flat blade screwdriver to push the main bearing into position while rotating the crankshaft.

Make sure the tang on the main bearing is located in the notch of the cylinder block.

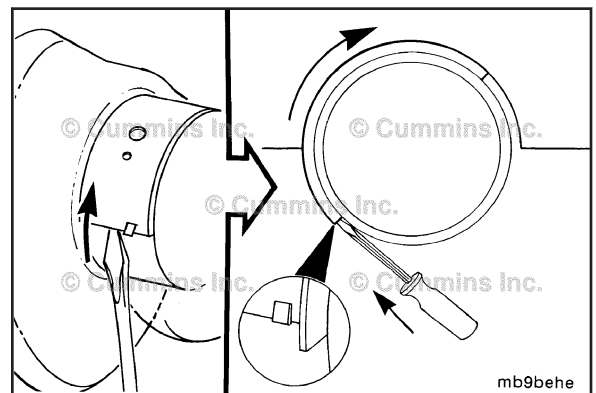

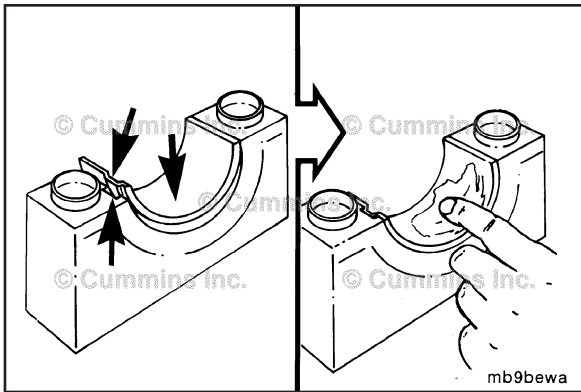

CAUTION

Do not lubricate the back side of the bearing that contacts the main bearing cap.

Lower Main Bearings

Making sure that the backside of the bearings are clean and free of debris, install the lower main bearings into the main bearing caps.

Make sure to align the tangs of the bearings with tangs on the main bearing caps.

NOTE: Some engines use a thrust bearing for the upper and lower main bearing (360 degree), while other engines only have a thrust bearing for the upper main bearing (180 degree). **Always** replace like for like.

If equipped, install the lower crankshaft thrust bearing.

Four cylinder engines - The number 4 main bearing position.

Six cylinder engines - The number 6 main bearing position.

Apply a coat of assembly lube, Part Number 3163087, to the crankshaft side of the main bearings and thrust bearing surfaces.

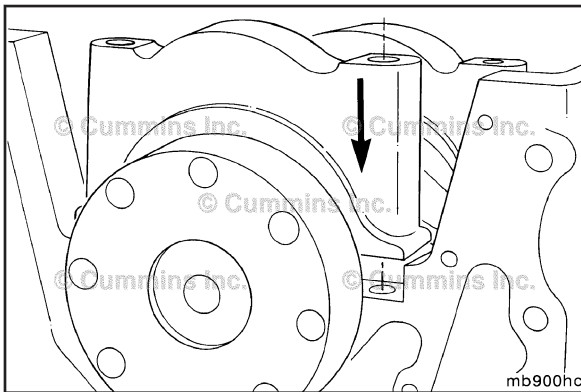

CAUTION

Make sure the caps are correctly installed in the same position as removed, with the number towards the oil cooler side of the engine.



Make sure the main bearing cap surfaces between the main bearing cap and block are clean and free of debris.

Install the main bearing cap into position, aligning the main bearing cap dowel rings with the cylinder block.

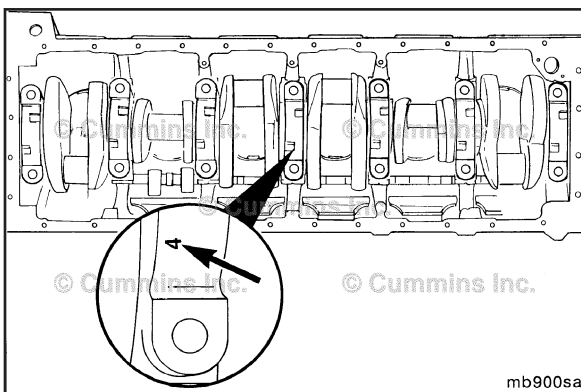

The main bearing caps are/were numbered during the removal process for their location. Number 1 starts with the front of the block.

NOTE: The caps **must** be installed so the numbers on the caps match the bearing saddle in the block. The lock tangs in the main bearing saddle and bearing cap **must** be on the same side.

Install the main bearing caps. Make sure to align the ring dowels on the main bearing cap with the corresponding drillings in the cylinder block.

Lubricate the main bearing capscrew threads and underside of the head with clean engine oil.

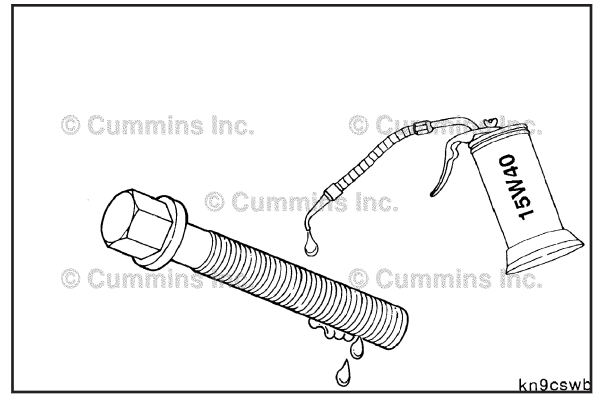

Gently tap the main bearing cap into position with a plastic or rubber mallet.



When seated, install the main bearing capscrews and tighten.

Torque Value: 50 N·m [37 ft-lb]

Do **not** tighten to the final torque value at this time. Final torque should be applied after all main bearing caps are installed.

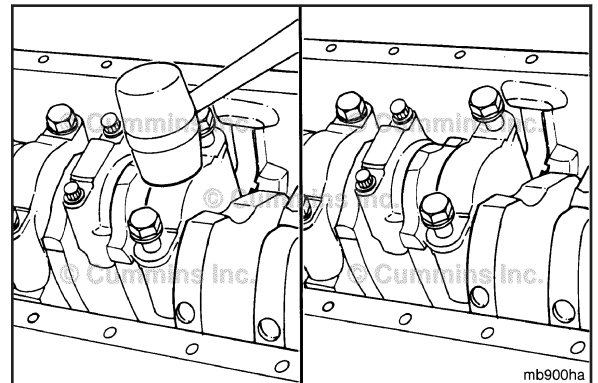

Using the barring tool, Part Number 3824591, the crankshaft **must** rotate freely after installing the main bearing caps.



While applying final torque to the main bearing capscrews, frequently check that the crankshaft rotates freely.

If the crankshaft does **not** rotate freely:

- 1 Check if the crankshaft is contacting one of the connecting rods
- 2 Check if the correct main bearing caps were installed correctly
- 3 Check if the main bearing cap ring dowels or mounting surfaces were damaged during installation
- 4 Check if the correct main bearings were installed.

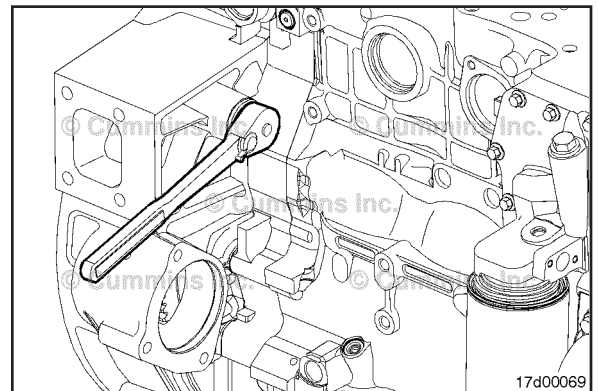

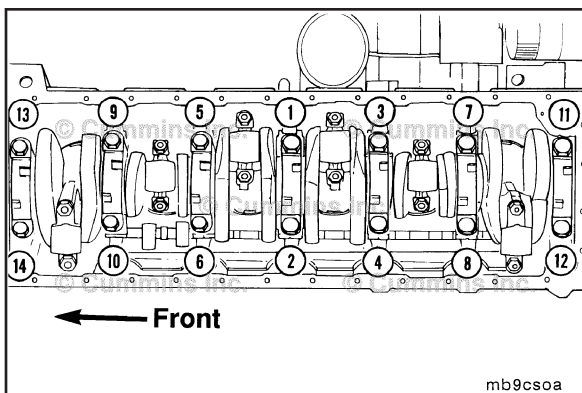

⚠ CAUTION ⚠

For 4.5L and 6.7L engines there is a different torque procedure for new and previously installed main bearing capscrews. Failure to use the correct torque process can result in engine damage.

NOTE: The sequence to the right is for a six cylinder engine. For a four cylinder engine, use the same sequence for the 5 main bearing caps.

Tighten the main bearing capscrews evenly and in sequence.

3.9L and 5.9L Main Bearing Capscrews

Torque Value:

Step 1	50 N•m	[37 ft-lb]
Step 2	80 N•m	[59 ft-lb]
Step 3	Rotate 90 degrees.	

4.5L and 6.7L Main Bearing Capscrews

Torque Value:

Previously Installed Main Bearing Capscrews

Step 1	60 N•m	[44 ft-lb]
Step 2	80 N•m	[59 ft-lb]
Step 3	Rotate 90 degrees.	

Torque Value:

New Main Bearing Capscrews

Step 1	120 N•m	[89 ft-lb]
Step 2	Loosen completely	
Step 3	60 N•m	[44 ft-lb]
Step 4	85 N•m	[63 ft-lb]
Step 5	Rotate 120 degrees.	

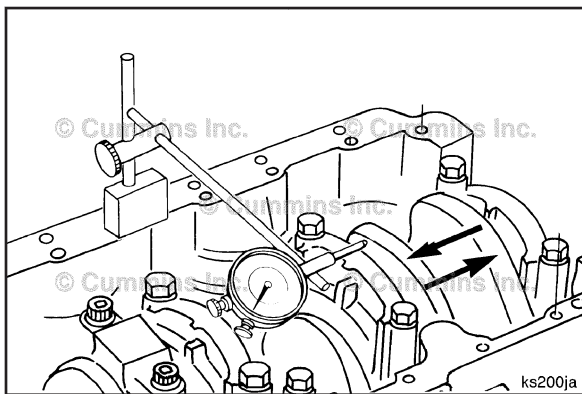

NOTE: The dimensions of the thrust bearing and crankshaft journal determine end play.

Measure the crankshaft end play using dial indicator, Part Number 3824564 and magnetic base, Part Number 3377399.

Crankshaft End Play

mm		in
0.102	MIN	0.004
0.432	MAX	0.017

If the crankshaft end play is **not** within specification:

- 1 If the crankshaft end play is below specification, check if there are any obstructions limiting the crankshaft's travel (lubricating oil pump, connecting rod, etc.)
- 2 If the crankshaft end play is above specification, inspect the crankshaft thrust bearing surface. Also check if the correct thrust bearing(s) were installed.

NOTE: Oversize thrust bearings are available if the end play is **not** within specifications. Oversize thrust bearings of 0.25 to 0.51 mm [0.010 to 0.020 in] are available.

Finishing Steps

Install block stiffener plate. Refer to Procedure 001-089 (Block Stiffener Plate) in Section 1.

Install the lubricating oil suction tube. Refer to Procedure 007-035 (Lubricating Oil Suction Tube (Block-Mounted)) in Section 7.

Fill the lubricating oil pan and gasket. Refer to Procedure 007-025 (Lubricating Oil Pan) in Section 7.

Fill the lubricating oil pan. Refer to Procedure 007-037 (Lubricating Oil System) in Section 7.

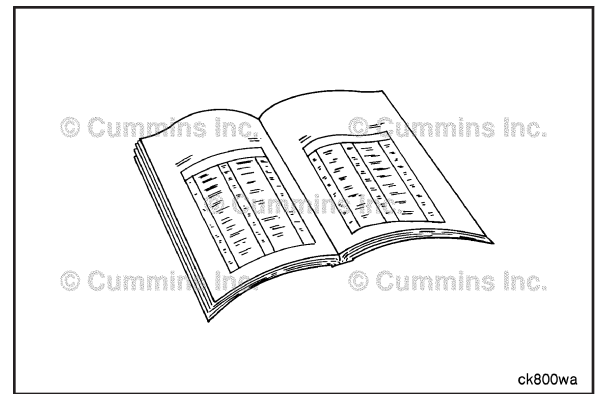

ck800wa

⚠ WARNING ⚠

Batteries can emit explosive gases. To reduce the possibility of personal injury, always ventilate the compartment before servicing the batteries. To reduce the possibility of arcing, remove the negative (-) battery cable first and attach the negative (-) battery cable last.

Connect the batteries.

Operate the engine at idle for 5 to 10 minutes. Check for loose parts, leaks and proper oil pressure.

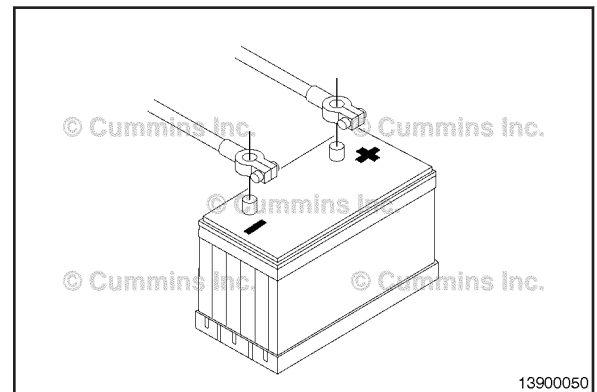

13900050

Camshaft (001-008)

Initial Check

This procedure covers both rear gear train engines (Automotive and Industrial) and front gear train engines (Automotive and Marine).

Prior to starting this procedure, make sure there is adequate clearance to remove the camshaft from the rear of the engine for rear gear train engines and from the front of the engine for front gear train engines.



Clearance from Front/Rear Gear Housing

	mm		in
Four Cylinder	609.6	MIN	24
Six Cylinder	812.8	MIN	32

NOTE: It may be necessary to remove OEM components (radiator, charge-air cooler assembly, etc.) for access. Refer to the OEM service manual.

If adequate clearance can **not** be obtained, the engine **must** be removed.

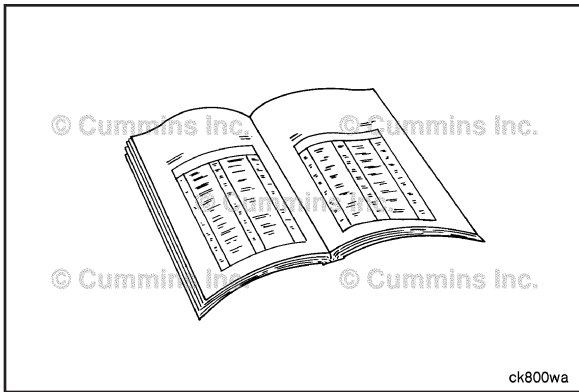

Preparatory Steps

Rear Gear Train



⚠ WARNING ⚠

Batteries can emit explosive gases. To reduce the possibility of personal injury, always ventilate the compartment before servicing the batteries. To reduce the possibility of arcing, remove the negative (-) battery cable first and attach the negative (-) battery cable last.

⚠ WARNING ⚠

Support the rear of the engine using the rear support attached to the rear of the cylinder block. Failure to support the engine can cause personal injury.

NOTE: The camshaft **must** be removed from the flywheel end of the engine.

- Disconnect the battery cables.
- Remove the transmission and all related components, if equipped. Refer to the OEM service manual.
- Remove the flywheel or flexplate. Refer to Procedure 016-005 in Section 16. Refer to Procedure 016-004 in Section 16.
- Remove the flywheel housing. Refer to Procedure 016-006 in Section 16.
- Remove the rocker lever cover. Refer to Procedure 003-011 in Section 3.
- Remove the rocker levers. Refer to Procedure 003-008 in Section 3.
- Remove the push rods. Refer to Procedure 004-014 in Section 4.
- Raise the tappets. Refer to Procedure 004-015 in Section 4.

Front Gear Train

⚠ WARNING ⚠

Batteries can emit explosive gases. To reduce the possibility of personal injury, always ventilate the compartment before servicing the batteries. To reduce the possibility of arcing, remove the negative (-) battery cable first and attach the negative (-) battery cable last.

NOTE: The camshaft **must** be removed from the vibration damper end of the engine.

- Disconnect the battery cables.
- Remove the rocker lever cover. Refer to Procedure 003-011 in Section 3.
- Remove the rocker levers. Refer to Procedure 003-008 in Section 3.
- Remove the push rods. Refer to Procedure 004-014 in Section 4.
- For marine applications, remove the sea water pump drive belt. Refer to Procedure 008-126 in Section 8.
- Remove the crankshaft position sensor. Refer to Procedure 019-365 in Section 19. This procedure is found in the ISB, ISB[®]4, QSB4.5, QSB6.7, ISC, QSC8.3, ISL, and QSL9 Engines, Electronic Control System, Troubleshooting and Repair Manual, Bulletin 4021416.
- Remove the drive belt. Refer to Procedure 008-002 in Section 8.
- Remove the fan hub, if required. Refer to Procedure 008-039 in Section 8.
- Remove the vibration damper/crankshaft speed indicator ring. Use the following procedure for viscous damper, if equipped. Refer to Procedure 001-052 in Section 1.
- Use the following procedure for rubber damper, if equipped. Refer to Procedure 001-051 in Section 1.
- Remove the gear cover. Refer to Procedure 001-031 in Section 1.
- Raise the tappets. Refer to Procedure 004-015 in Section 4.

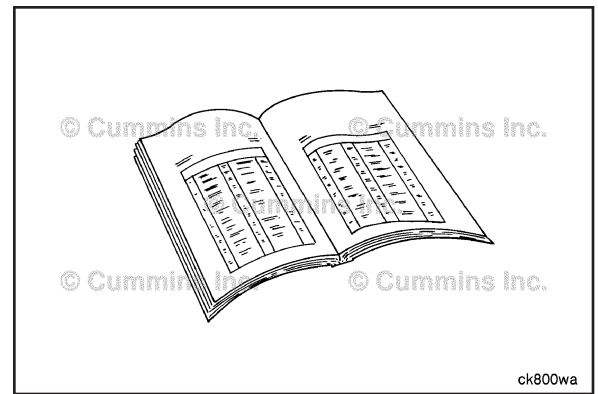

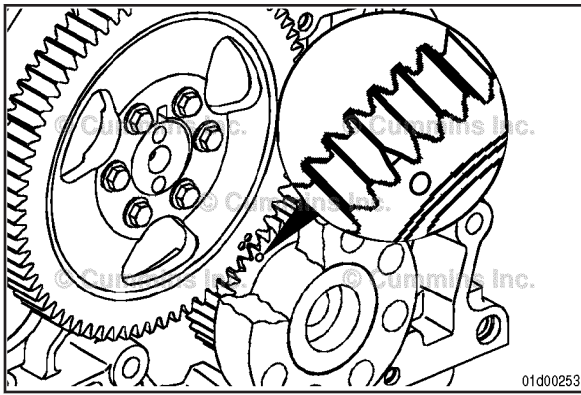

Remove

Rear Gear Train

NOTE: The engine can have either a mark on the crankshaft gear or a chamfered tooth.

Rotate the engine to align the timing marks on the camshaft and crankshaft gear. When the timing marks are aligned, cylinder 1 is at top dead center (TDC).

Service Tip: The engine can be rotated by installing two of the flywheel/flexplate mounting capscrews half way. Place a pry bar between the two capscrews to rotate the engine.

Service Tip: Engines equipped with air compressors may require that the air compressor be timed to the engine. To make sure that the air compressor is properly timed when the camshaft gear is later installed, scribe an alignment line on the air compressor and camshaft gear before removing the camshaft gear.

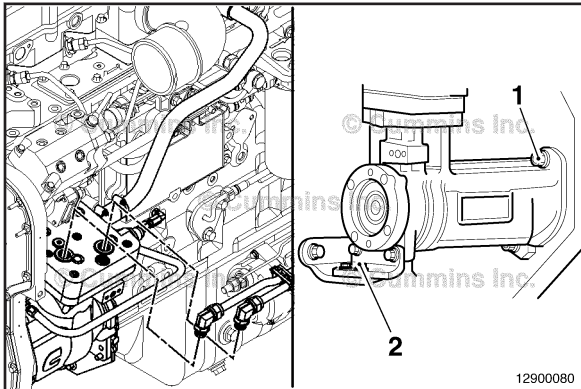

On engines equipped with an air compressor/Accessory drive, it may be necessary to loosen/remove some of the air compressor/Accessory drive mounting hardware in order to remove the camshaft gear. It is **not** necessary to remove the air compressor/Accessory drive completely.

Loosening or removing some of the air compressor/Accessory drive mounting hardware will give enough clearance to remove the camshaft gear.

Loosen the air compressor mounting fasteners (1).

Remove the two capscrews securing the air compressor support (2).

If equipped with a hydraulic pump driven off of the air compressor, it may be necessary to remove and/or loosen some or all of the mounting fasteners. Refer to the OEM service manual.

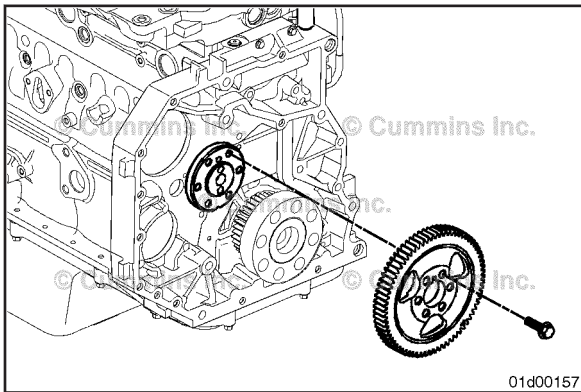

Remove the camshaft gear capscrews and remove the camshaft gear. Refer to Procedure 001-012 in Section 1.



NOTE: On engines equipped with an air compressor/Accessory drive, it may be necessary to move the air compressor/Accessory drive to gain clearance to remove the camshaft gear.

Remove the thrust plate capscrews and the thrust plate.

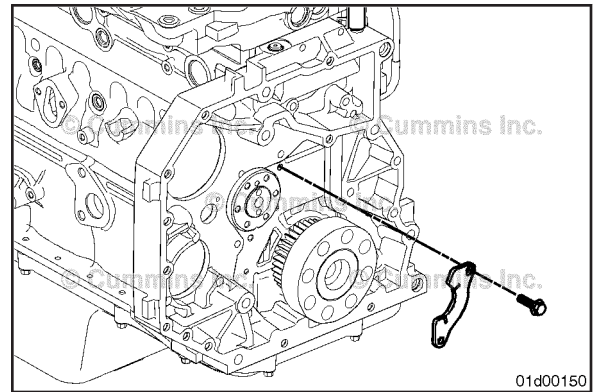

⚠ CAUTION ⚠

The camshaft will drop once the camshaft clears the last bushing, if not supported. This can cause damage to the camshaft journal or, if equipped, the camshaft speed indicator ring.

Use a gear puller, service tool Part Number ST647, or equivalent, to attach to the end of the camshaft, where the camshaft gear mounts, to act as a handle. This will give proper leverage and ease in removing the camshaft.

Slide the camshaft out of the bore using the installed gear puller.

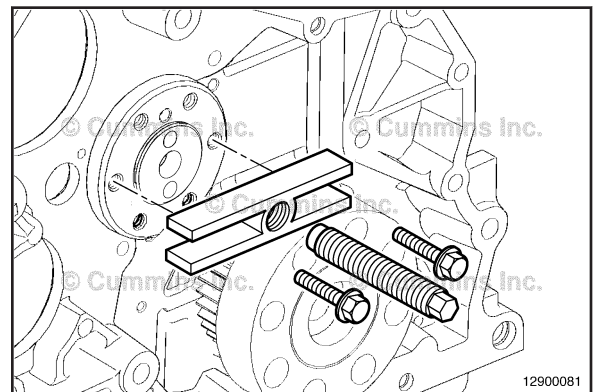

Front Gear Train

Use barring tool, Part Number 3824591, to rotate the crankshaft to align the crankshaft to camshaft gear timing marks.

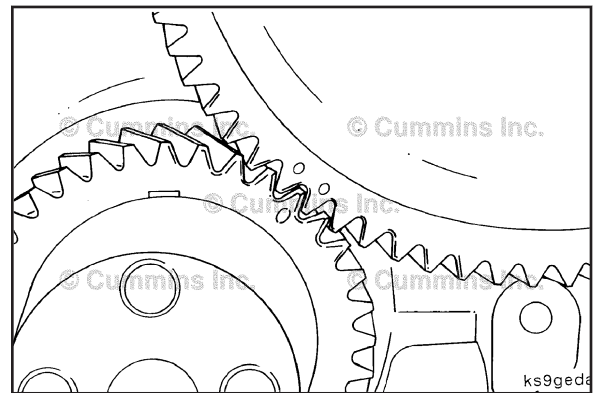

Because the thrust plate extends more than 180 degrees around the camshaft, the thrust plate can **only** be removed from the camshaft after removing the camshaft gear from the camshaft.

Remove the capscrews from the thrust plate.

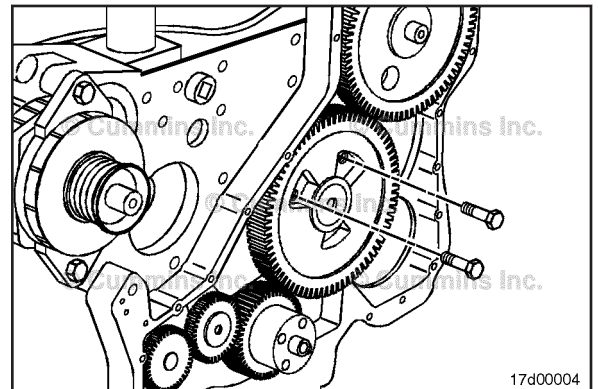

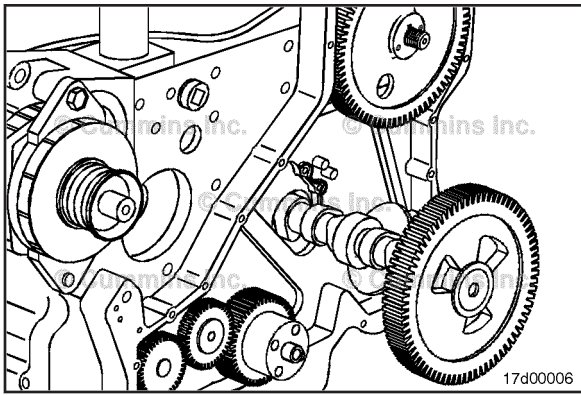

Remove the camshaft, camshaft gear, and thrust plate as an assembly.

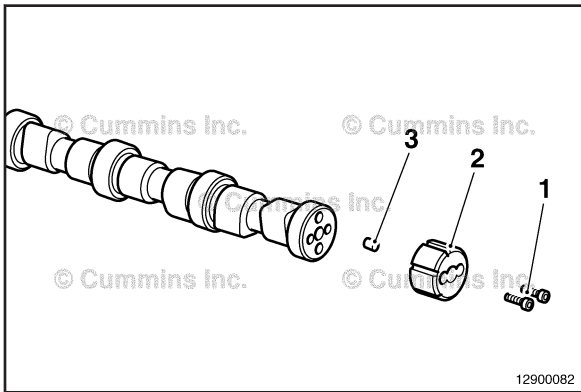

Disassemble Rear Gear Train

If equipped, remove the Allen head capscrews (1), camshaft speed indicator ring (2), and locating dowel ring (3) from the end of the camshaft.

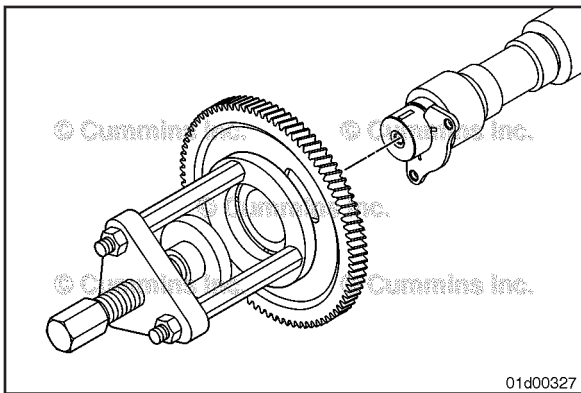

Front Gear Train

Remove the camshaft gear, thrust plate, and locating key. Refer to Procedure 001-013 in Section 1.

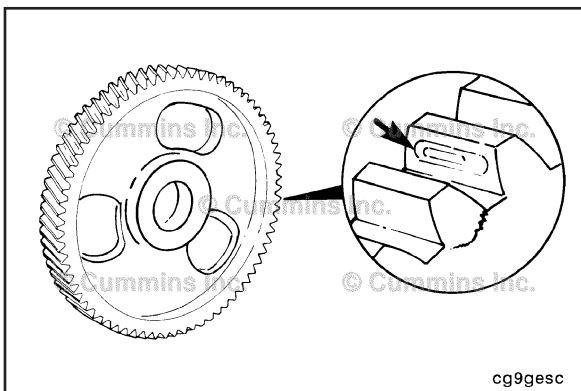

Clean and Inspect for Reuse

Inspect the camshaft gear.



Use the following procedure for rear gear train engines. Refer to Procedure 001-012 in Section 1.

Use the following procedure for front gear train engines. Refer to Procedure 001-013 in Section 1.

Inspect the camshaft bushing. Refer to Procedure 001-010 in Section 1.

NOTE: Front gear train engines have a front camshaft bushing. Rear gear train engines have a rear camshaft bushing. Some engines may be equipped with both.

Only inspect the camshaft bushing on the same side of the engine the camshaft was removed.

NOTE: Inspection of the rest of the camshaft bushings and camshaft block bores is **not** necessary, unless during the inspection of the camshaft, damage was noted on the camshaft journals.

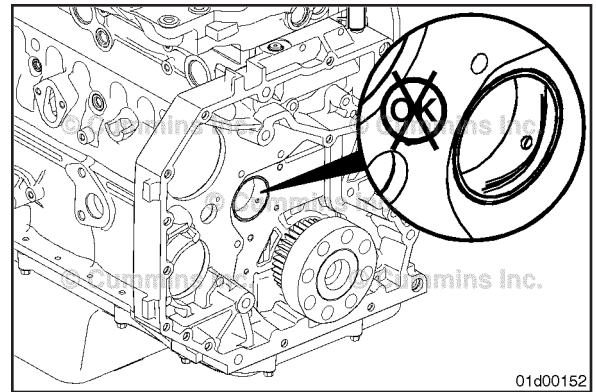

⚠ WARNING ⚠

When using solvents, acids, or alkaline materials for cleaning, follow the manufacturer's recommendations for use. Wear goggles and protective clothing to reduce the possibility of personal injury.

⚠ WARNING ⚠

Wear appropriate eye and face protection when using compressed air. Flying debris and dirt can cause personal injury.

Clean the camshaft with solvent and dry with compressed air.

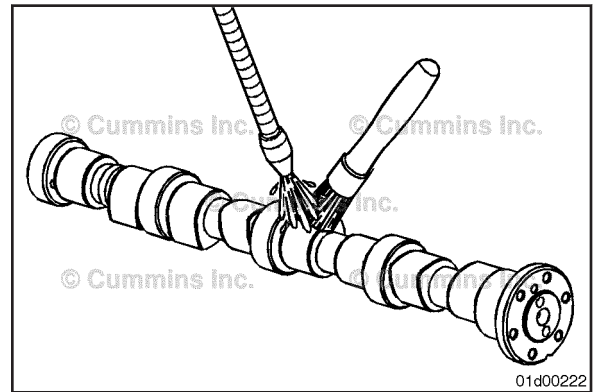

Inspect the valve lobes and bearing journals for cracking, pitting, or scoring.

Inspect the camshaft gear mounting surface on the camshaft to make sure the camshaft gear locating dowel pin is in place, and is **not** bent, sheared, or cracked.

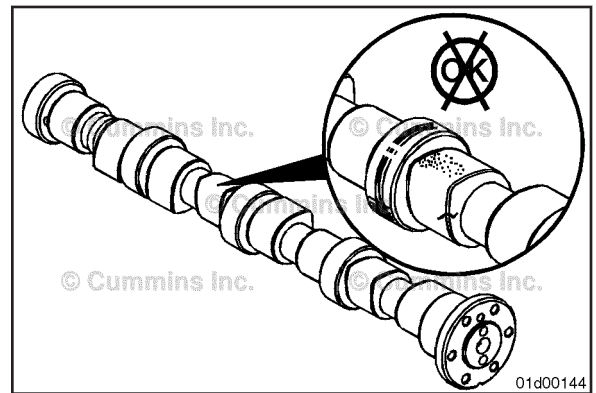

See Service Bulletin 3666475, Camshaft and Tappet Reuse Guidelines, for reuse guidelines for cast iron camshafts.

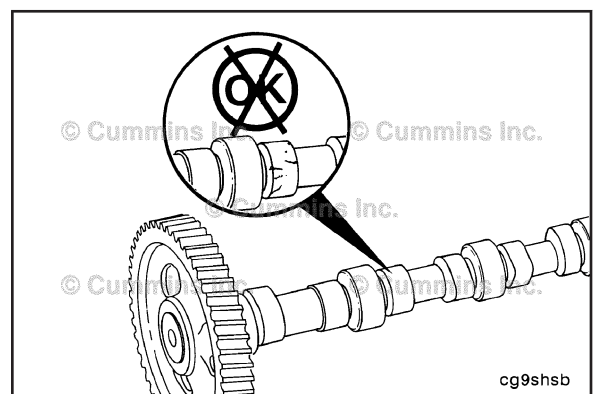

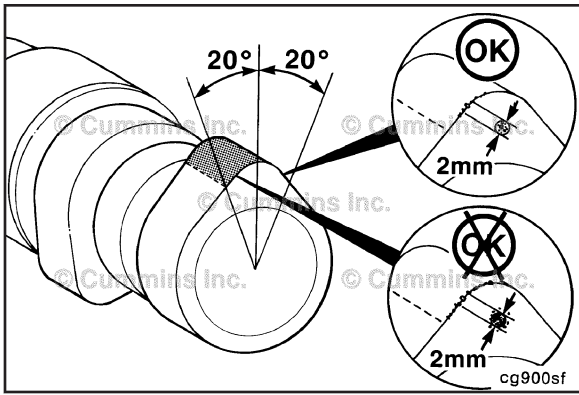

Edge Deterioration (breakdown) Criteria

The area of edge deterioration **must not** be greater than the equivalent area of a 2-mm [0.079-in] circle within ± 20 degrees of the nose of the camshaft lobe.

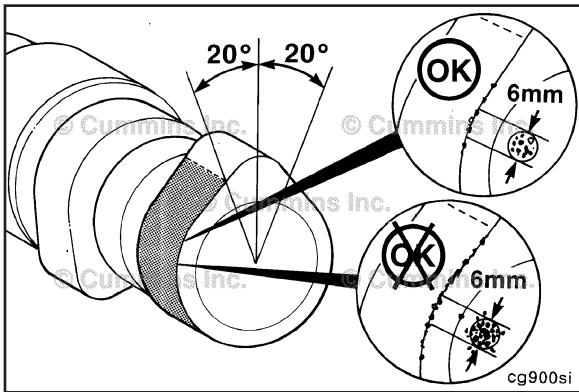

Outside of the ± 20 degrees of the nose of the camshaft lobe, the areas of edge deterioration **must not** be greater than the equivalent area of a 6-mm [0.236-in] circle.



NOTE: If the camshaft shows any pitting or wear, remove and inspect the tappets before installing the camshaft. Refer to Procedure 004-015 in Section 4. If a new camshaft is installed, new tappets **must** also be installed.

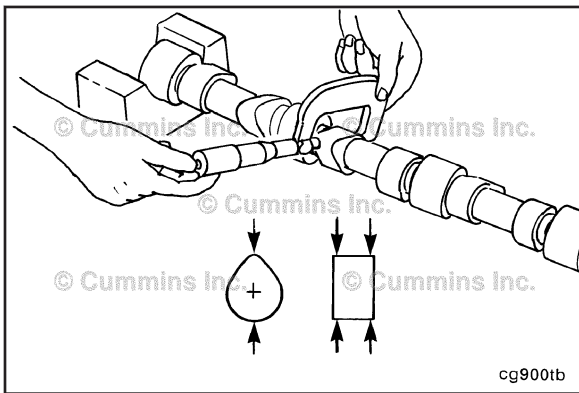

Measure

Measure the peak of the camshaft valve lobes.

Diameter of Peak of Lobe

	mm		in
Intake	47.175	MIN	1.857
	47.855	MAX	1.884
Exhaust	45.632	MIN	1.797
	46.312	MAX	1.823

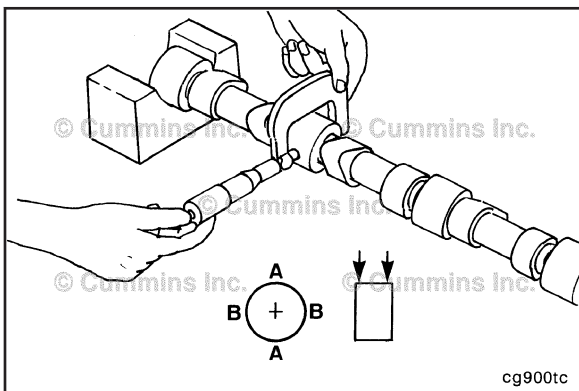

Measure the camshaft bearing journals.

Journal Diameter

mm		in
53.995	MIN	2.1258
54.045	MAX	2.1278

Measure the camshaft thrust plate thickness.

Camshaft Thrust Plate Thickness (Front Gear Train Engines)

mm		in
9.40	MIN	0.370
9.60	MAX	0.378

Camshaft Thrust Plate Thickness (Rear Gear Train Engines)

mm		in
5.25	MIN	0.207
5.35	MAX	0.211

If the camshaft thrust plate is out of specification, replace the thrust plate.

NOTE: On front gear train engines, the camshaft thrust plate thickness can **only** be measured if the camshaft gear is removed from the camshaft. The camshaft thrust plate thickness can also be verified by checking camshaft end play during installation.

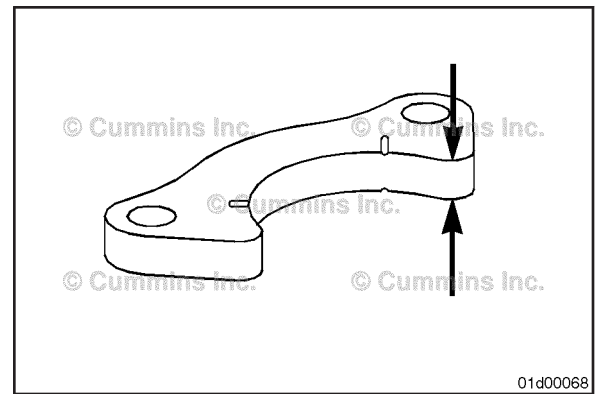

Assemble

Rear Gear Train

If previously equipped, install the Allen head capscrews (1), camshaft speed indicator ring (2), and locating dowel ring (3) on to the end of the camshaft.

Torque Value: 10 N•m [89 in-lb]

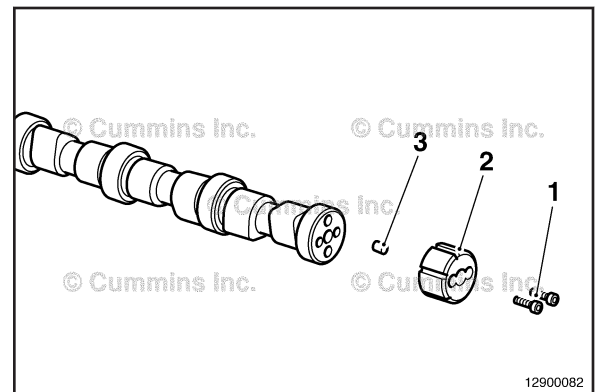

Front Gear Train

Install the camshaft gear locating key, camshaft gear, and thrust plate. Refer to Procedure 001-013 in Section 1.

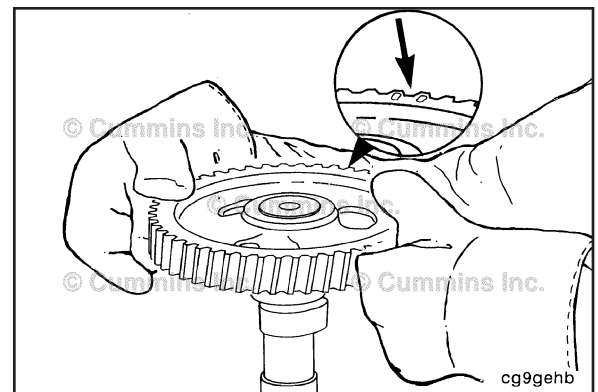

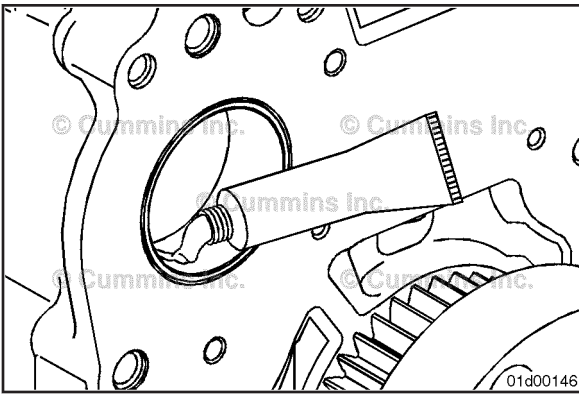

Install Rear Gear Train

Apply assembly lubricant, Part Number 3163087, to the rear camshaft bore.

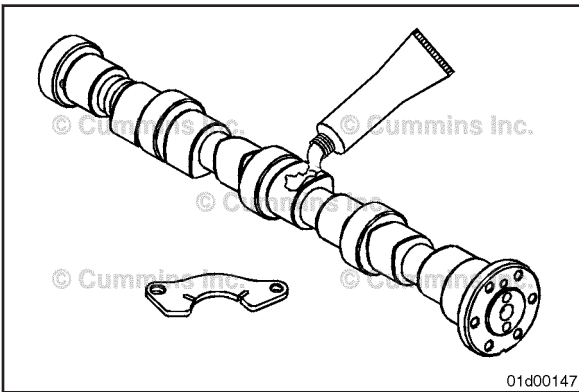

Lubricate the camshaft lobes, journals, and thrust washer with assembly lubricant, Part Number 3163087.

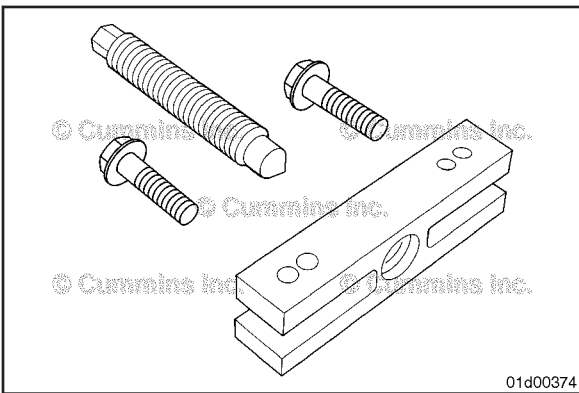

Use a gear puller, Part Number ST647, or equivalent, to attach to the end of the camshaft where the camshaft gear mounts, to act as a handle. This will give proper leverage and simplify of installation of the camshaft.

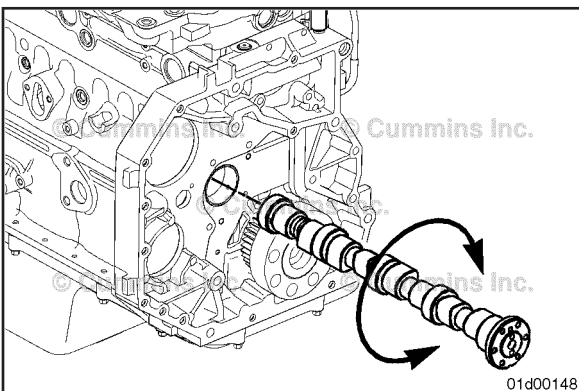

CAUTION

Do not force the camshaft into the camshaft bore as damage to the camshaft bushing can result.

Install the camshaft. While pushing in slightly, rotate the camshaft and carefully work the camshaft through the camshaft bushings. As each camshaft journal passes through a bushing, the camshaft will drop slightly and the camshaft lobes will catch on the bushings. Rotating the camshaft will free the lobe from the bushing and allow the camshaft installation to continue.

Install the thrust plate.

Torque Value: 24 N•m [212 in-lb]

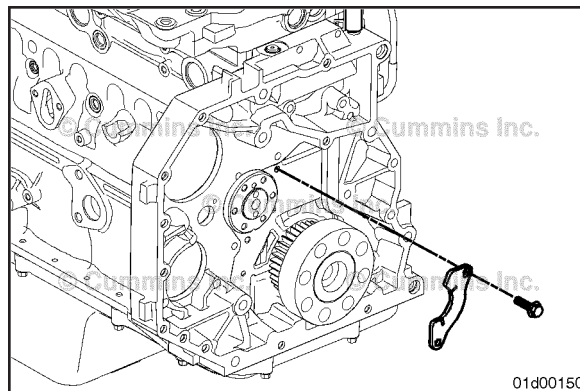

⚠ CAUTION ⚠

To reduce the possibility of engine damage, make sure the camshaft rotates freely.

NOTE: The engine can have either a mark on the crankshaft gear or a chamfered tooth.

Align the timing marks on the camshaft gear with the timing marks on the crankshaft gear and tighten the camshaft capscrews.

NOTE: If equipped with an air compressor, make sure to align the scribed line on the camshaft gear and air compressor gear. If this was **not** done, use the following procedure for air compressor timing. Refer to Procedure 012-014 in Section 12.

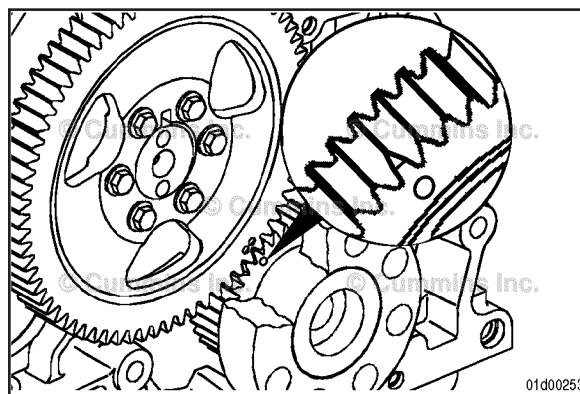

Rotate the camshaft so that the camshaft dowel pin aligns with the slot on the camshaft gear. Install the camshaft gear and capscrews.

Tighten the capscrews.

Torque Value: 36 N•m [27 ft-lb]

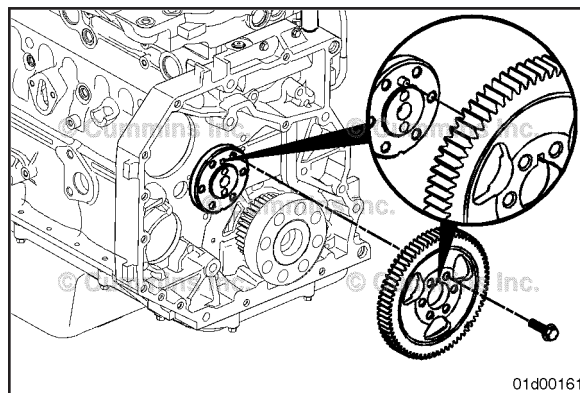

Use a gauge, Part Number 3824564, and magnetic base, Part Number 3377399, to verify the camshaft has proper end play and backlash.



Camshaft End Play (A)

mm		in
0.10	MIN	0.004
0.36	MAX	0.014

Camshaft Gear Backlash Limits (B)

mm		in
0.076	MIN	0.003
0.280	MAX	0.011

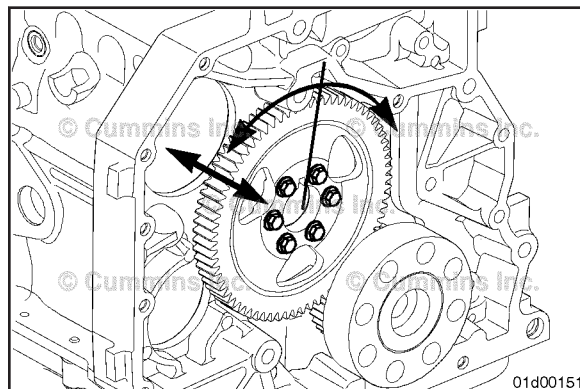

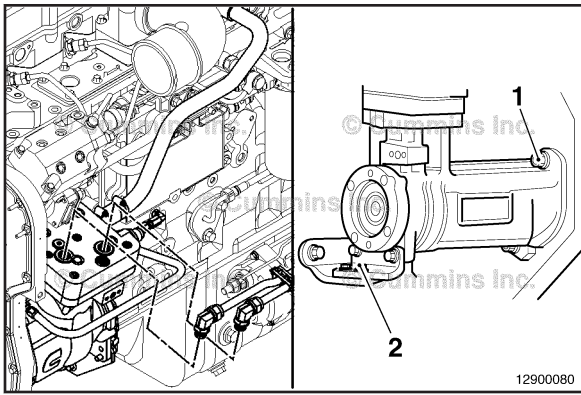

⚠ CAUTION ⚠

On engines equipped with an air compressor/ accessory drive, before tightening the air compressor mounting fasteners, inspect to see that the seals/ gaskets are in place. Failure to inspect may result in an oil leak or blockage of the air compressor oil passages, which will damage the air compressor.



Tighten the air compressor/accessory drive mounting fasteners (1).

Torque Value: 77 N•m [57 ft-lb]

Install the two capscrews securing the air compressor support (2).

Torque Value:

M8 24 N•m [212 in-lb]

Torque Value:

M10 43 N•m [32 ft-lb]

Torque Value:

M12 77 N•m [57 ft-lb]

If equipped with a hydraulic pump driven off the air compressor, install and/or tighten any of the mounting fasteners removed. Refer to the OEM service manual.

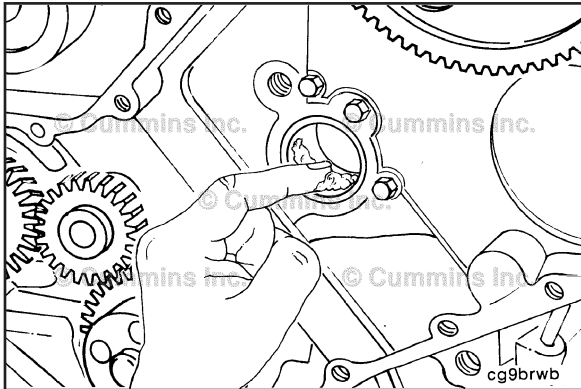

Front Gear Train

Apply assembly lubricant, Part Number 3163087, to the front camshaft bore.

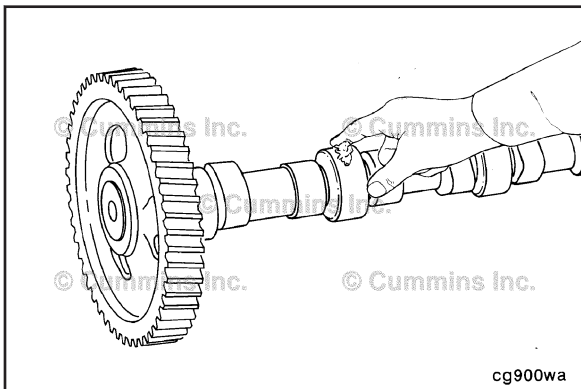

Lubricate the camshaft lobes, journals, and thrust plate with assembly lubricant, Part Number 3163087.

⚠ CAUTION ⚠

Do not try to force the camshaft into the camshaft bore as damage to the camshaft bushing can result.

Install the camshaft. While pushing in slightly, rotate the camshaft and carefully work the camshaft through the camshaft bushings. As each camshaft journal passes through a bushing, the camshaft will drop slightly and the camshaft lobes will catch on the bushings. Rotating the camshaft will free the lobe from the bushing and allow the camshaft installation to continue.

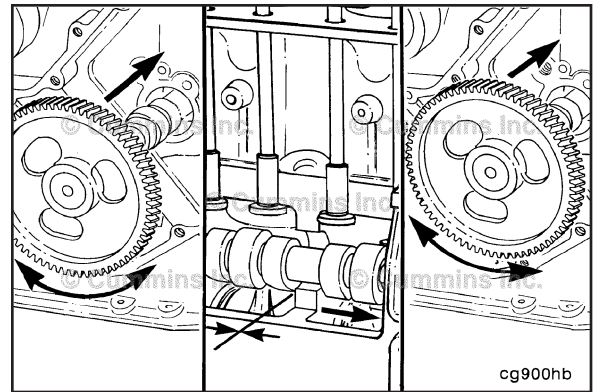

⚠ CAUTION ⚠

To reduce the possibility of engine damage, make sure the camshaft rotates freely.

Before the camshaft gear engages the crankshaft gear, check the camshaft for ease of rotation. When installed properly, the camshaft **must** rotate freely.

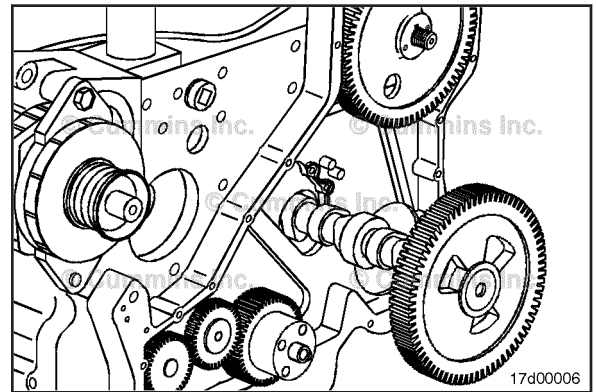

Align the timing marks as illustrated and install the camshaft.

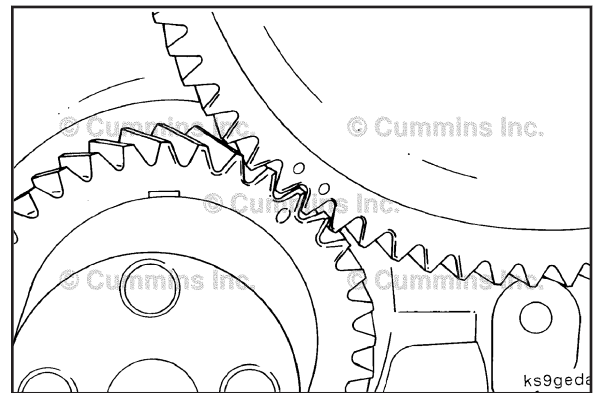

Install the thrust plate capscrews.

Torque Value: 24 N•m [212 in-lb]

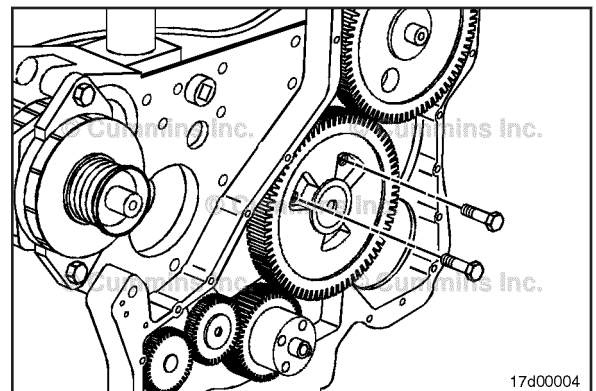

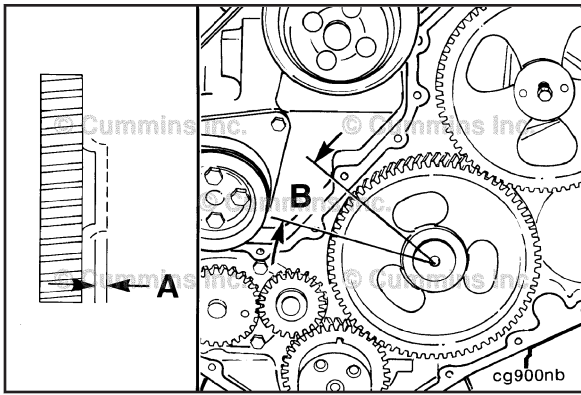

Use gauge, Part Number 3824564, and magnetic base, Part Number 3377399, to verify that the camshaft has proper backlash and end play.

Camshaft End Play (A)

mm		in
0.12	MIN	0.005
0.50	MAX	0.020

Camshaft Gear Backlash Limits (B)

mm		in
0.08	MIN	0.003
0.25	MAX	0.010

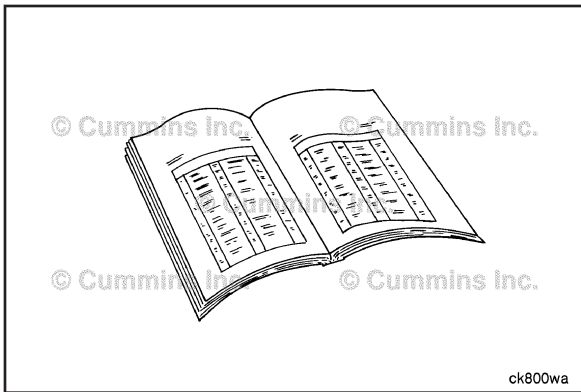

Finishing Steps

Rear Gear Train



WARNING

Batteries can emit explosive gases. To reduce the possibility of personal injury, always ventilate the compartment before servicing the batteries. To reduce the possibility of arcing, remove the negative (-) battery cable first and attach the negative (-) battery cable last.

- Lower the tappets. Refer to Procedure 004-015 in Section 4.
- Install the push rods. Refer to Procedure 004-014 in Section 4.
- Install the rocker levers. Refer to Procedure 003-008 in Section 3.
- Adjust the valve lash. Refer to Procedure 003-004 in Section 3.
- Install the rocker lever cover. Refer to Procedure 003-011 in Section 3.
- Install the flywheel housing. Refer to Procedure 016-006 in Section 16.
- Install the flywheel or flexplate. Refer to Procedure 016-005 in Section 16. Refer to Procedure 016-004 in Section 16.
- Install the transmission and all related components, if equipped. Refer to the OEM service manual.
- Connect the battery cables.
- Operate the engine and check for leaks.

Front Gear Train

▲ WARNING ▲

Batteries can emit explosive gases. To reduce the possibility of personal injury, always ventilate the compartment before servicing the batteries. To reduce the possibility of arcing, remove the negative (-) battery cable first and attach the negative (-) battery cable last.

- Install the front gear cover. Refer to Procedure 001-031 in Section 1.
- Install the vibration damper/crankshaft speed indicator ring. Use the following procedure for a viscous damper, if equipped. Refer to Procedure 001-052 in Section 1.
- Use the following procedure for rubber damper, if equipped. Refer to Procedure 001-051 in Section 1.
- Install and connect the crankshaft position sensor. Refer to Procedure 019-365 in Section 19. This procedure is found in the ISB, ISB⁴, QSB4.5, QSB5.9, QSB6.7, ISC, QSC8.3, ISL, and QSL9 Engines, Electronic Control System, Troubleshooting and Repair Manual, Bulletin 4021416.
- Release the tappets. Refer to Procedure 004-015 in Section 4.
- Install the push rods. Refer to Procedure 004-014 in Section 4.
- Install the rocker levers. Refer to Procedure 003-008 in Section 3.
- Adjust the valve lash. Refer to Procedure 003-004 in Section 3.
- Install the rocker lever cover. Refer to Procedure 003-011 in Section 3.
- Install the fan hub, if required. Refer to Procedure 008-039 in Section 8.
- Install the drive belt. Refer to Procedure 008-002 in Section 8.
- For marine applications, install the sea water pump drive belt. Refer to Procedure 008-126 in Section 8.
- Connect the battery cables.
- Operate the engine at idle for 5 to 10 minutes and check for leaks and loose parts.

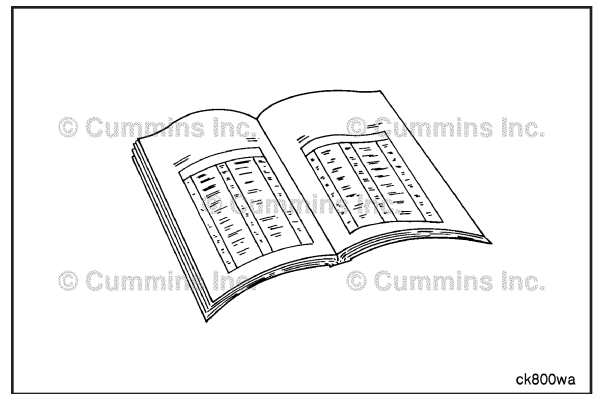

Camshaft Bushings (001-010)

General Information

Some engines are only built with a camshaft bushing installed in the first camshaft bore on the same side of the engine that the camshaft is removed and installed (front gear train engines, at the front of the engine and rear gear trains, at the rear of the engine). Some engines also have a second camshaft bushing at the opposite end of the engine from which the camshaft was removed and installed.

From production, there are no camshaft bushings installed in the inner block camshaft journal bores. If the inner block camshaft journal bores are damaged, the journal bores can be machined for camshaft bushings. See the Clean and Inspect for Reuse step of this procedure for specifications.

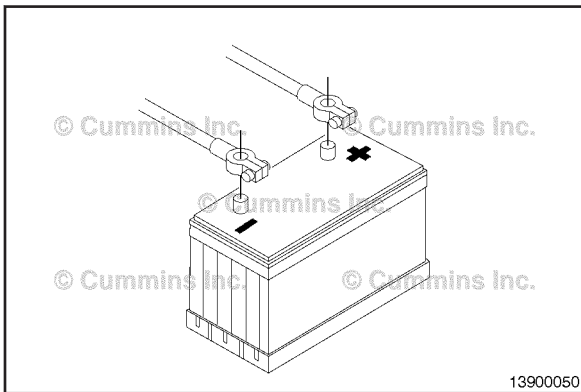

Preparatory Steps

⚠ WARNING ⚠

Batteries can emit explosive gases. To reduce the possibility of personal injury, always ventilate the compartment before servicing the batteries. To reduce the possibility of arcing, remove the negative (-) battery cable first and attach the negative (-) battery cable last.

Disconnect the batteries.

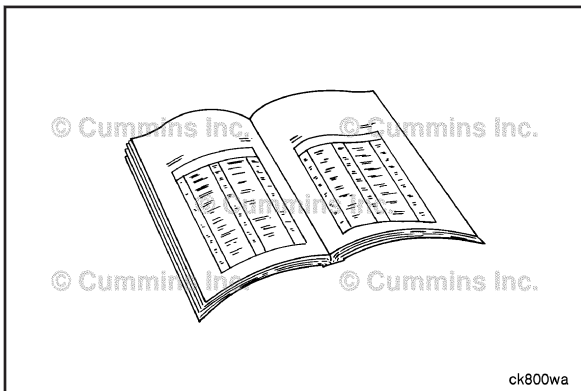

⚠ WARNING ⚠

To avoid the possibility of personal injury, avoid direct contact of hot oil with your skin.



⚠ WARNING ⚠

Some state and federal agencies have determined that used engine oil can be carcinogenic and cause reproductive toxicity. Avoid inhalation of vapors, ingestion, and prolonged contact with used engine oil. If not reused, dispose of in accordance with local environmental regulations.

Remove the camshaft. Refer to Procedure Procedure 001-008

Drain the lubricating oil. Refer to Procedure Procedure 007-037

Remove the oil pan and oil pan gasket. Refer to Procedure Procedure 007-025

Initial Check

Inspect the camshaft bushing at the end of the engine in which the camshaft was removed for scoring, scuffing or excessive wear.

If damage to the camshaft bushing is found, remove and replace the camshaft bushing.

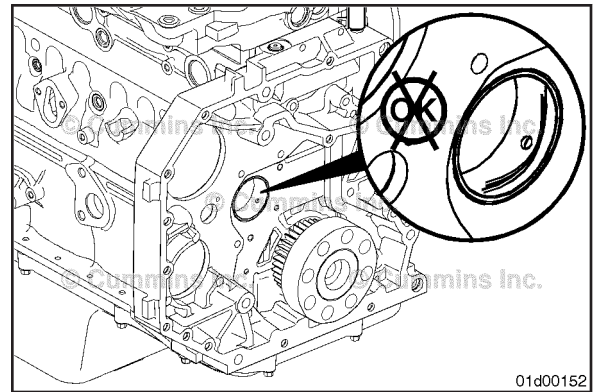

From below the engine, inspect if a camshaft bushing is installed at the opposite end of the engine in which the camshaft was removed.

If a camshaft bushing is present, inspect the camshaft bushing for scoring, scuffing or excessive wear.

If damage to the camshaft bushing is found, remove and replace the camshaft bushing.

To replace the camshaft bushing, you must first:

For Rear Gear Train Engines:

Remove the front gear cover. Refer to Procedure Procedure 001-031

For Front Gear Train Engines:

Remove the flywheel housing. Refer to Procedure Procedure 016-006

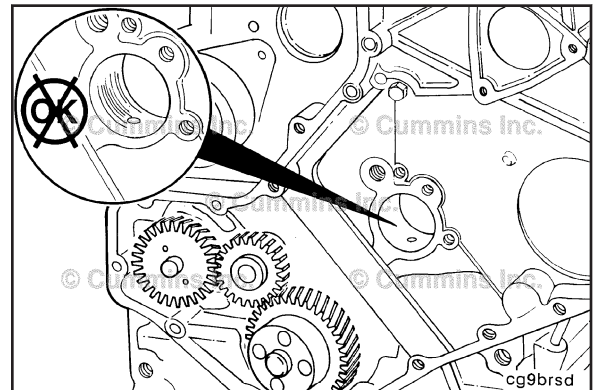

From below the engine, inspect the inner camshaft bores for scoring, scuffing or excessive wear.

NOTE: During a previous repair, camshaft bushings may have been installed.

For camshaft bore specifications see the Inspect for Reuse step of this procedure.

If damage to the inner camshaft bores is found, machine the camshaft bores oversize to install standard camshaft bushings. See the Inspect for Reuse step for specifications.

If the damage to the bore(s) is beyond machining, replace the block. Refer to Procedure Procedure 001-026

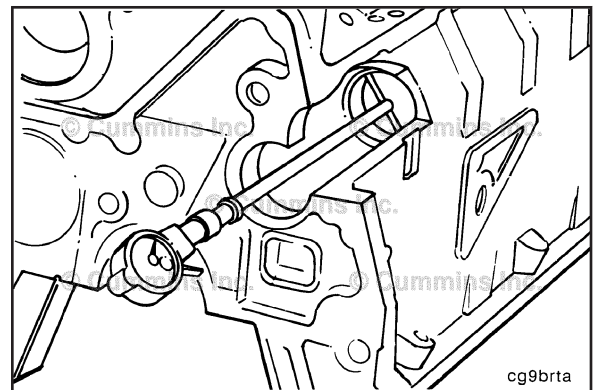

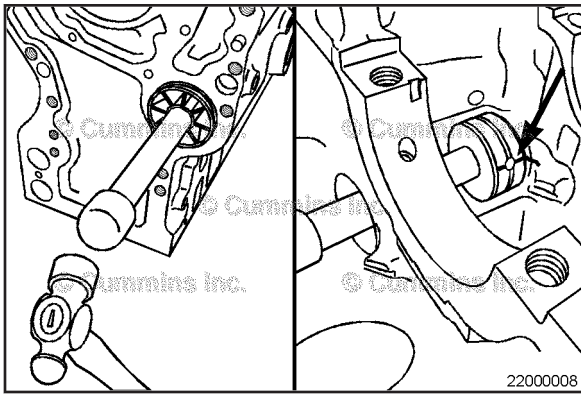

Remove

Remove the camshaft bushings using the camshaft bushing replacer kit, Part Number 3165045. The tool will drive the camshaft bushing to the inside of the block. The camshaft bushing can be retrieved from the bottom of the engine.

NOTE: Once removed, camshaft bushings can **not** be reused.

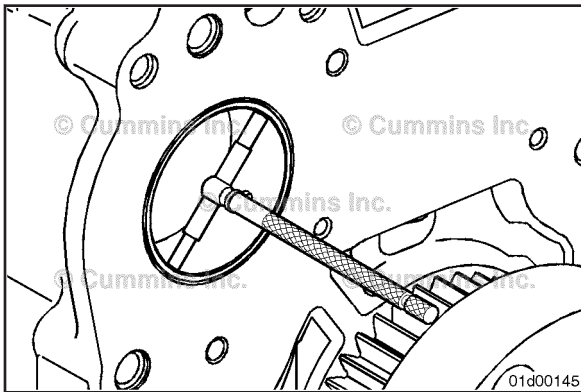

Inspect for Reuse

Measure the camshaft bores **without** the camshaft bushing installed.

Camshaft Bore Diameter without camshaft bushing (maximum)

	mm		in
Camshaft Bore (Camshaft Bushing Previously Installed)	59.248	MAX	2.3326
Camshaft Bore (Camshaft Bushing not Previously Installed)	54.164	MAX	2.1324

If a camshaft bushing was previously installed and the camshaft bore is out of specification, the block **must** be replaced. Refer to Procedure Procedure 001-026. No oversize cam bushings are available.

If a camshaft bore in which a camshaft bushing was **not** previously installed is damaged or out of specification, the camshaft bore can be machined oversize to install a standard camshaft bushing.

Machine the damaged bore to a maximum of 59.248 mm (2.3326 in) to accept a standard bushing.

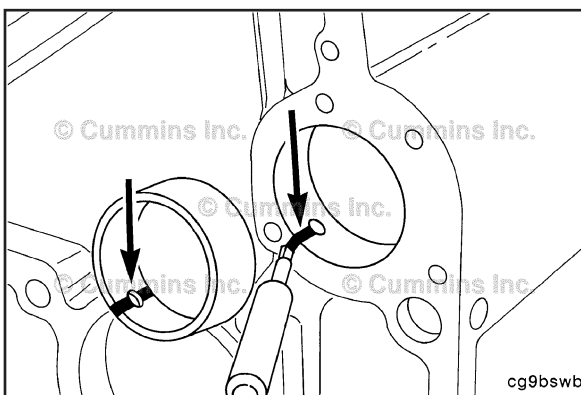

Install

Mark the camshaft bushing and cylinder block so you can align the lubricating oil hole in the cylinder block with the large lubricating oil hole in the bushing.



Slide the camshaft bushing on the replacer tool. Align the marks on the camshaft bushing and the cylinder block.

Drive the camshaft bushing to the correct installed depth. The correct installed depth is when the camshaft bushing end is flush with the machined face of the block and the oil hole aligns with the cylinder block oil hole.

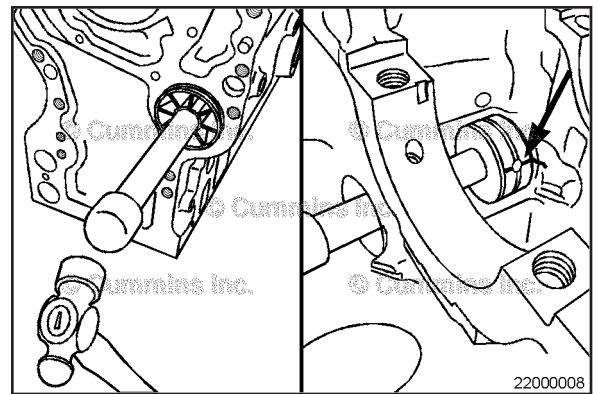

Be sure the large lubricating oil hole is aligned.

A 3.2 mm [0.128 in] diameter rod **must** be able to pass through the lubricating oil hole.

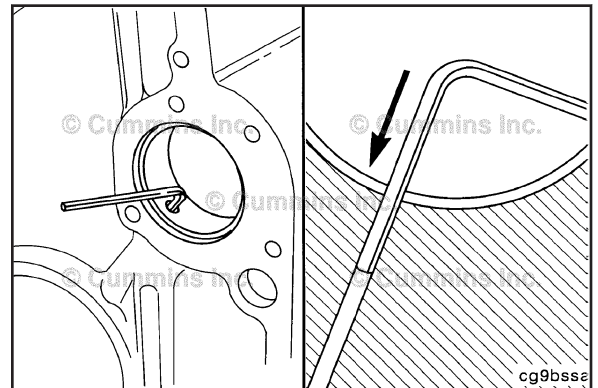

Measure

Measure the installed camshaft bushing.

Camshaft Bore (Bushing Installed)		
mm		in
54.083	MIN	2.1293
54.147	MAX	2.1318

If the camshaft bore with the camshaft bushing installed is out of specification, remove the camshaft bushing and inspect the camshaft bore.

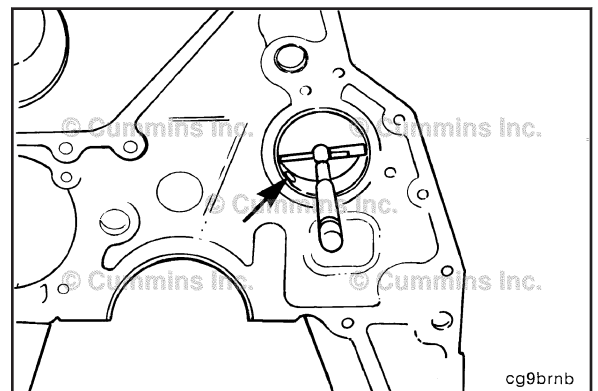

Finishing Steps

Install the camshaft. Refer to Procedure Procedure 001-008

Install the oil pan gasket and oil pan. Refer to Procedure Procedure 007-025

Fill the engine with clean lubricating oil. Refer to Procedure Procedure 007-037

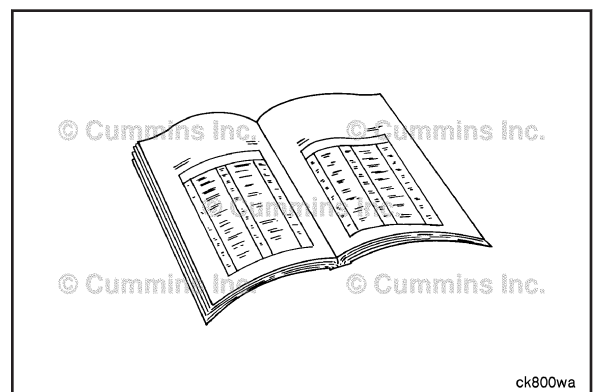

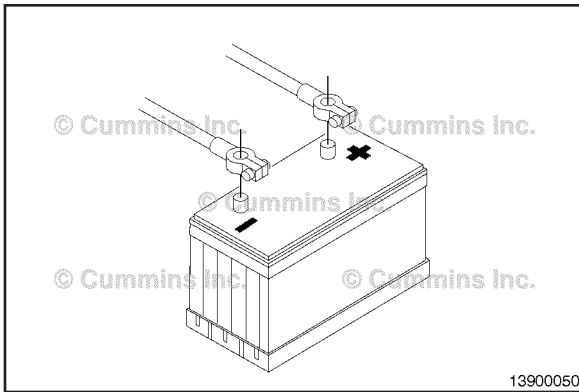

⚠ WARNING ⚠

Batteries can emit explosive gases. To reduce the possibility of personal injury, always ventilate the compartment before servicing the batteries. To reduce the possibility of arcing, remove the negative (-) battery cable first and attach the negative (-) battery cable last.



Connect the batteries.

Operate the engine and check for leaks.



Camshaft Gear (Camshaft Installed) (001-012)

General Information

This procedure applies to rear gear train engines **only**. Front gear train engine? Refer to Procedure 001-013 in Section 1.

Preparatory Steps

⚠ WARNING ⚠

Batteries can emit explosive gases. To reduce the possibility of personal injury, always ventilate the compartment before servicing the batteries. To reduce the possibility of arcing, remove the negative (-) battery cable first and attach the negative (-) battery cable last.

⚠ WARNING ⚠

Support the rear of the engine using the rear support attached to the rear of the cylinder block. Failure to support the engine can cause serious personal injury.

⚠ WARNING ⚠

This assembly weighs 23 kg [50 lb] or more. To reduce the possibility of personal injury, use a hoist or get assistance to lift this assembly.

- Disconnect the batteries. Refer to the OEM service manual.
- Remove the transmission. Refer to the OEM service manual.
- Remove the starting motor. Refer to Procedure 013-020 in Section 13.
- Remove the flywheel or flexplate. Refer to Procedure 016-005 in Section 16.
- Remove the flywheel or flexplate. Refer to Procedure 016-004 in Section 16.
- Remove the flywheel housing. Refer to Procedure 016-006 in Section 16.

Remove

Rotate the engine to allow the camshaft timing marks to align. When the timing marks are aligned, cylinder 1 is at top dead center (TDC).

NOTE: The engine can have a mark on the camshaft gear or chamfered tooth.

Service Tip: Engines equipped with air compressors may require that the air compressor be timed to the engine. To make sure that the air compressor is properly timed when the camshaft gear is later installed, scribe an alignment line on the air compressor and camshaft gear before removing the camshaft gear.

On engines equipped with an air compressor, it is necessary to loosen the air compressor mounting hardware in order to remove the camshaft gear. It is **not** necessary to remove the air compressor completely. Loosening the air compressor will give enough clearance to remove the camshaft gear.

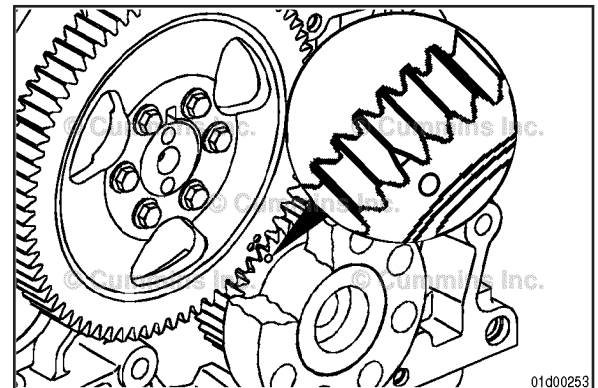
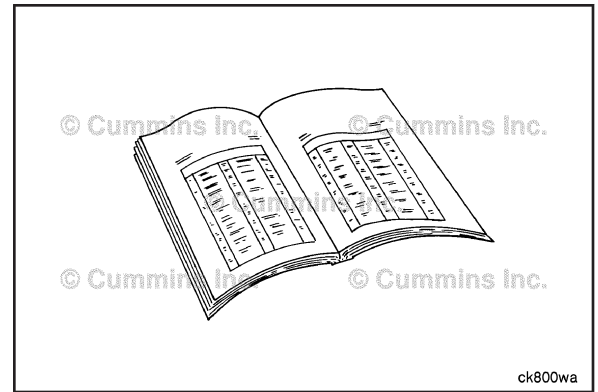

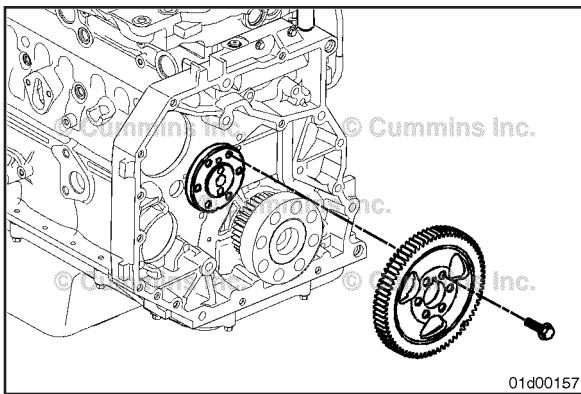

Remove the camshaft gear cap screws.
Remove the camshaft gear.

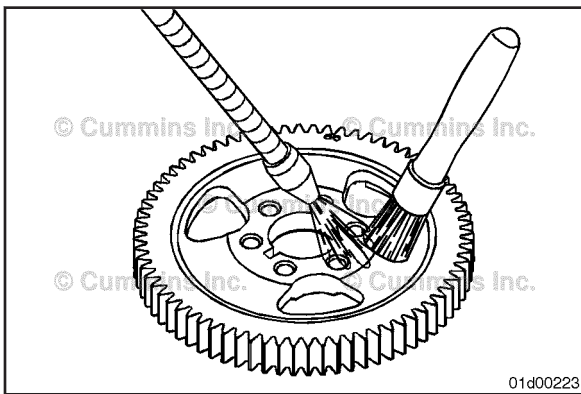

Clean and Inspect for Reuse

⚠️ WARNING ⚠️

When using solvents, acids, or alkaline materials for cleaning, follow the manufacturer's recommendations for use. Wear goggles and protective clothing to reduce the possibility of personal injury.

⚠️ WARNING ⚠️

Wear appropriate eye and face protection when using compressed air. Flying debris and dirt can cause personal injury.

Clean the camshaft gear. Dry with compressed air.

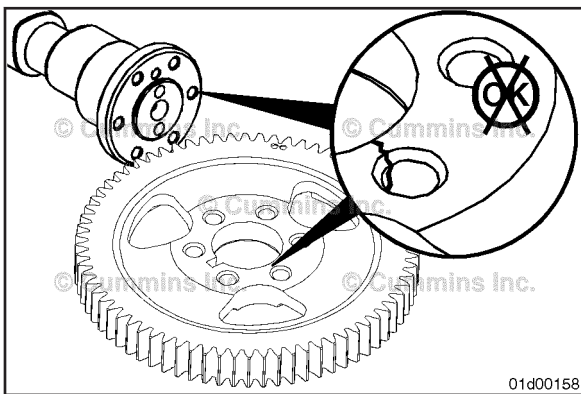

Inspect for cracks and fretting at the cap screw holes on the camshaft and camshaft gear.

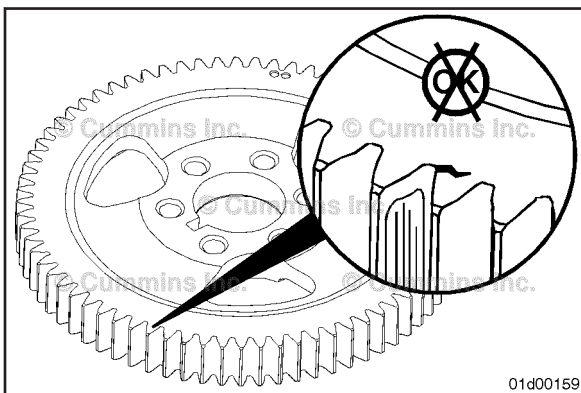

Inspect for fretting on the camshaft gear teeth.
Inspect for cracked or broken teeth on the camshaft gear.

Engines With Machined Speed Sensor Targets.
Inspect the cam gear and speed sensor targets.
Replace the gear if any damage is found.

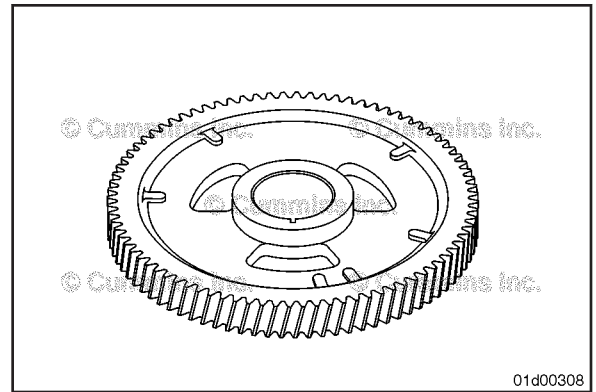

Remove any frets, burrs, or raised metal with abrasive pad, Part Number 3823258.

If frets, burrs, or raised metal can **not** be removed with abrasive pad, Part Number 3823258, replace the gear.

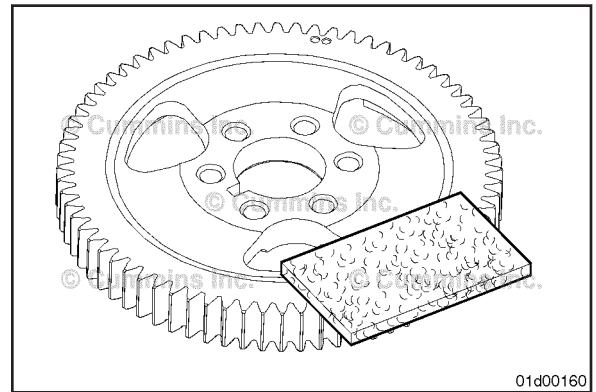

Install

⚠CAUTION⚠

To reduce the possibility of engine damage, make sure the camshaft rotates freely.

Align the camshaft gear with the pin in the camshaft and the mark on the crankshaft gear.

Install camshaft gear onto the camshaft.

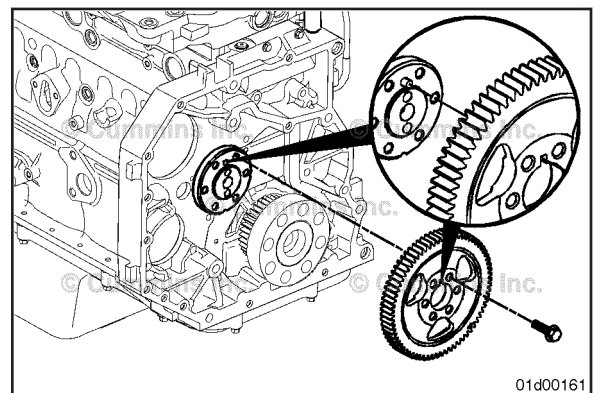

Check to make sure the timing marks on the camshaft gear align with the timing marks on the crankshaft gear. If equipped with an air compressor, make sure to align the line that was scribed on the camshaft gear and air compressor gear during the camshaft gear removal step. Refer to Procedure 012-014 in Section 12.

NOTE: The engine can have a mark on the crankshaft gear or chamfered tooth.

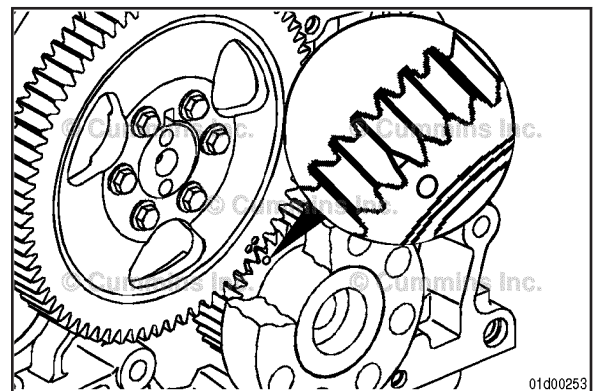

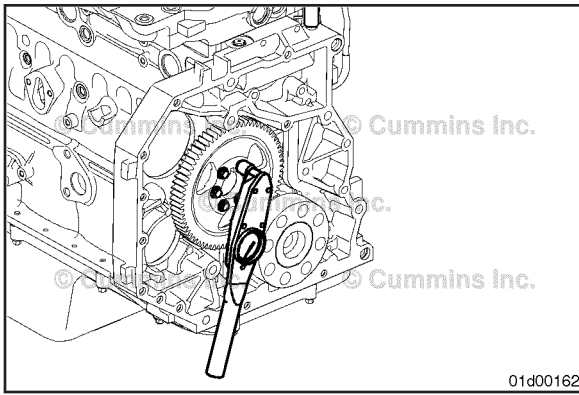

Install the camshaft gear capscrews and tighten.

Torque Value: 36 N•m [27 ft-lb]

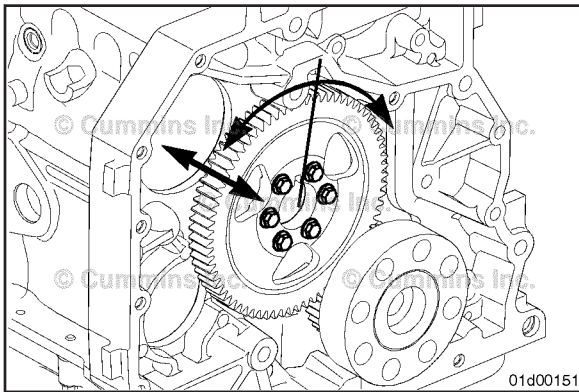

Measure

Use gauge, Part Number 3824564, and magnetic base, Part Number 3377399, to check the camshaft end play.

Camshaft End Play

mm		in
0.100	MIN	0.004
0.360	MAX	0.014

Check the camshaft backlash.

Camshaft Backlash

mm		in
0.076	MIN	0.003
0.280	MAX	0.011

Finishing Steps

⚠ WARNING ⚠

Batteries can emit explosive gases. To reduce the possibility of personal injury, always ventilate the compartment before servicing the batteries. To reduce the possibility of arcing, remove the negative (-) battery cable first and attach the negative (-) battery cable last.

⚠ WARNING ⚠

Support the rear of the engine using the rear support attached to the rear of the cylinder block. Failure to support the engine can cause serious personal injury.

⚠ WARNING ⚠

This assembly weighs 23 kg [50 lb] or more. To reduce the possibility of personal injury, use a hoist or get assistance to lift this assembly.

- On engines equipped with an air compressor, before tightening the air compressor inspect to see that the seals/gaskets are in place. Tighten the air compressor mounting fasteners. Refer to Procedure 012-014 in Section 12.
- Install the flywheel. Refer to Procedure 016-005 in Section 16.
- Install the flexplate. Refer to Procedure 016-004 in Section 16.
- Install the flywheel housing. Refer to Procedure 016-006.
- Install the starter motor. Refer to Procedure 013-020 in Section 13.
- Install the transmission. Refer to the OEM service manual.
- Connect the batteries. Refer to the OEM service manual.
- Operate engine and check for leaks.

Camshaft Gear (Camshaft Removed) (001-013)

General Information

This procedure is for front gear train engines **only** in which the camshaft has already been removed. Refer to Procedure Procedure 001-008

NOTE: For rear gear train engines, the camshaft gear **must** be removed to remove the camshaft. Refer to Procedure Procedure 001-012

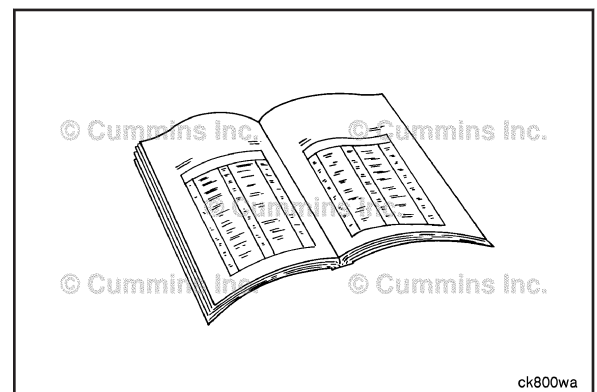
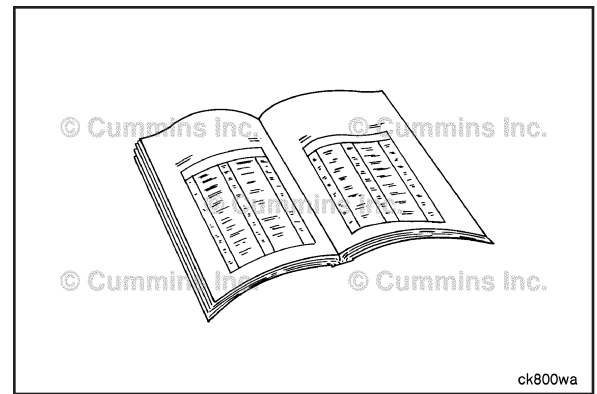

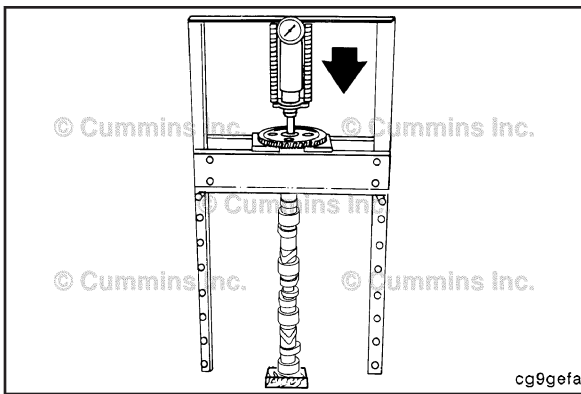

Remove

The camshaft gear can be removed from the camshaft by the following methods:

⚠CAUTION⚠

The camshaft gear must be fully supported when using a hydraulic press. Failure to properly support the camshaft gear will result in damage to the camshaft gear.

Use a hydraulic press

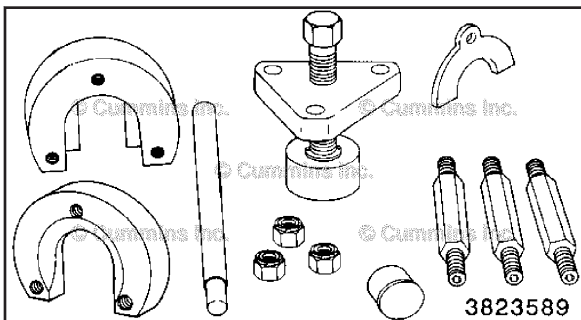

Use the camshaft gear removal and installation tool, Part Number 3823589.

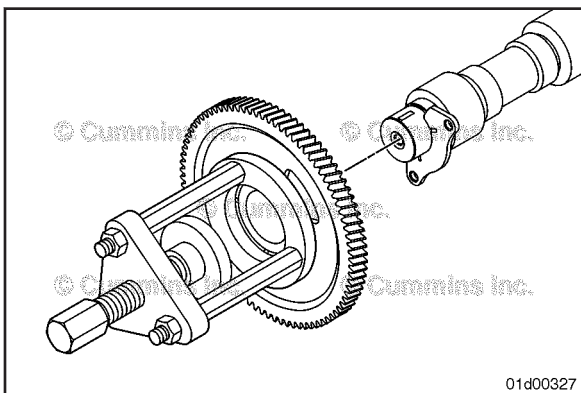

Remove the camshaft gear from the nose of the camshaft.

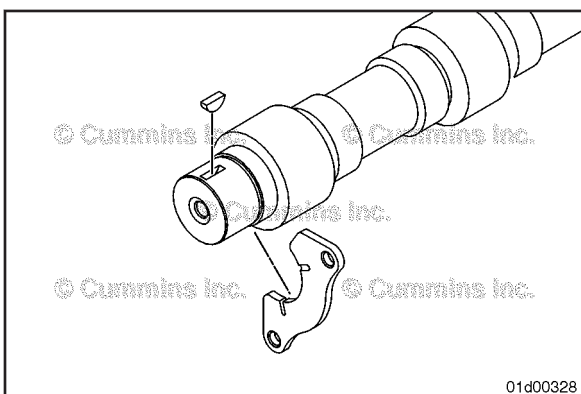

NOTE: Because the thrust plate extends more than 180 degrees around the camshaft, the thrust plate can **only** be removed from the camshaft after removing the camshaft gear from the camshaft.

Remove the thrust plate.

Remove the camshaft gear locating key or dowel pin.

Clean and Inspect for Reuse

⚠ WARNING ⚠

When using solvents, acids, or alkaline materials for cleaning, follow the manufacturer's recommendations for use. Wear goggles and protective clothing to avoid personal injury.

⚠ WARNING ⚠

Some solvents are flammable and toxic. Read the manufacturer's instructions before using.

⚠ WARNING ⚠

Wear appropriate eye and face protection when using compressed air. Flying debris and dirt can cause personal injury.

Use solvent to clean the camshaft gear.

Dry with compressed air.

Inspect the camshaft gear teeth for pitting. Look for cracks at the root of the teeth.

Inspect the camshaft gear teeth for discoloration or signs of excessive heat (bluing).

If any damage is present, replace the camshaft gear.

NOTE: If there is damage to the camshaft gear teeth or there are signs of excessive heat, make sure to inspect the associated crankshaft and fuel pump gears for damage. Measure camshaft gear backlash upon installation.

NOTE: If the fretting, burrs, or raised material burrs can not be removed, with Scotch-Brite™ 7448, replace camshaft gear

Inspect the camshaft bore for fretting or burrs.

Inspect the camshaft gear for burrs.

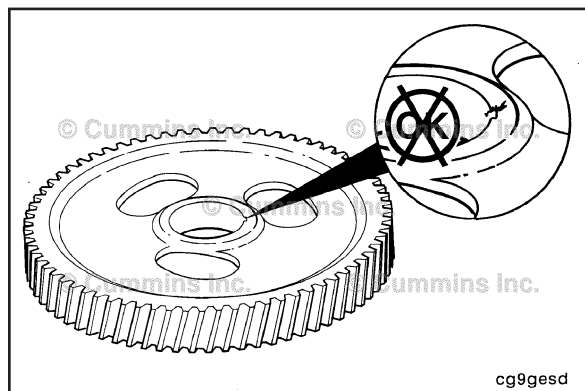
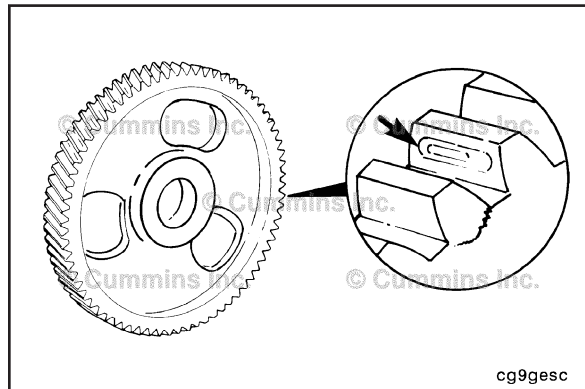
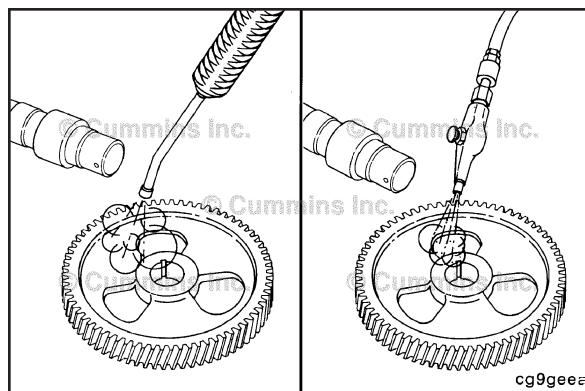

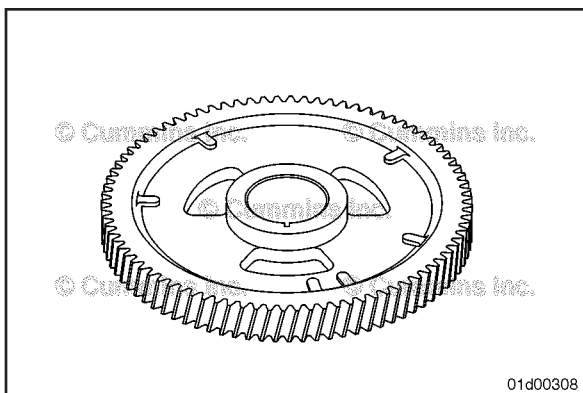

For engines with machined engine speed sensor/position targets, inspect the cam gear and speed sensor targets.
Replace the gear if any damage is found.

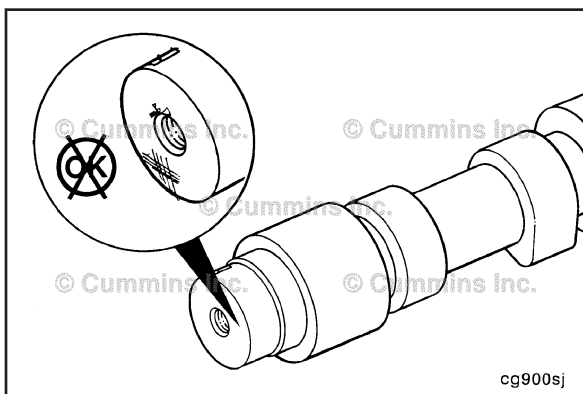

Inspect the camshaft nose for frets or burrs.
NOTE: If frets or burrs can **not** be removed with Scotch-Brite 7448 abrasive hand pad, or equivalent, replace the camshaft.

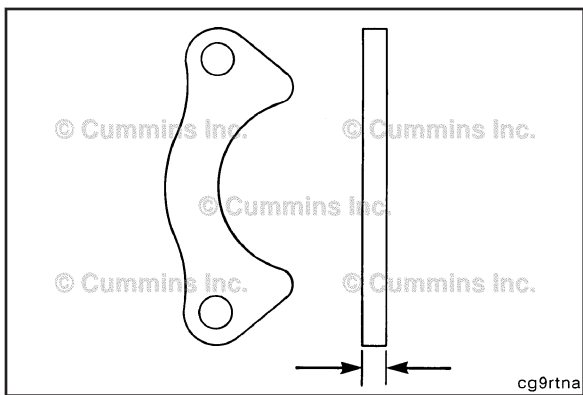

Measure

Measure camshaft thrust plate thickness.

Camshaft Thrust Plate		
mm		in
9.40	MIN	0.370
9.60	MAX	0.378

If the camshaft thrust plate is out of specification, replace the thrust plate.

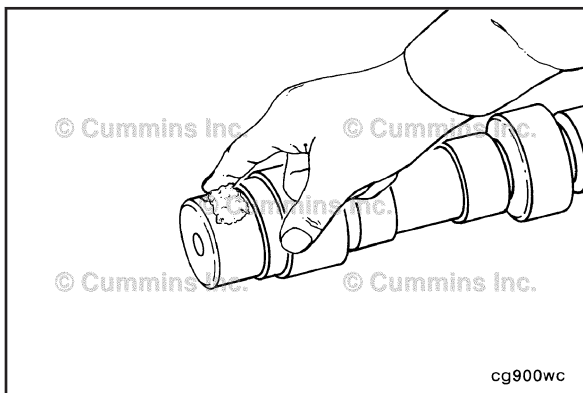

Install

Lubricate the camshaft nose with Lubriplate™ 105, or equivalent.

NOTE: Because the thrust plate extends more than 180 degrees around the camshaft, the thrust plate **must** be installed before the camshaft gear.



Install the camshaft thrust plate onto the nose of the camshaft until it contacts the first camshaft journal.

Install the camshaft gear locating key or dowel pin with a plastic mallet.

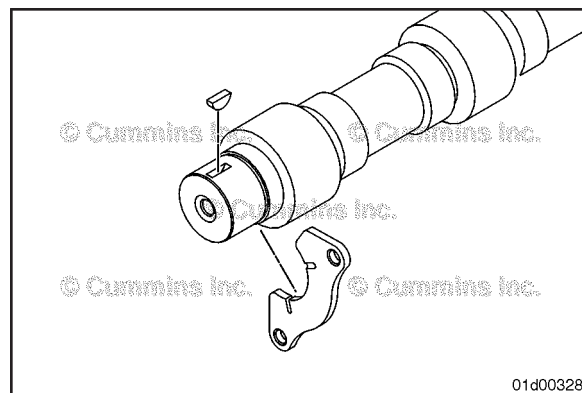

The camshaft gear can be installed by using the following methods:



⚠ CAUTION ⚠

The camshaft gear will be permanently distorted if overheated. The oven temperature must never exceed 177°C [350°F].

Heat the steel camshaft gear to 177°C [350°F] for 45 minutes.

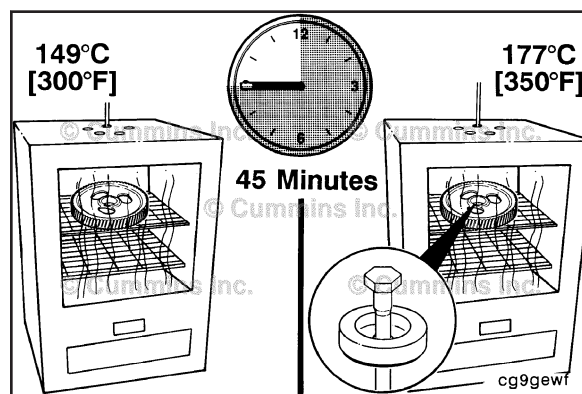

⚠ WARNING ⚠

To prevent personal injury, wear protective gloves to handle the hot gear.

Install the camshaft gear with the timing marks away from the camshaft.

Install the camshaft gear onto the nose of the camshaft. Align the camshaft gear keyway with the camshaft locating key/dowel pin.

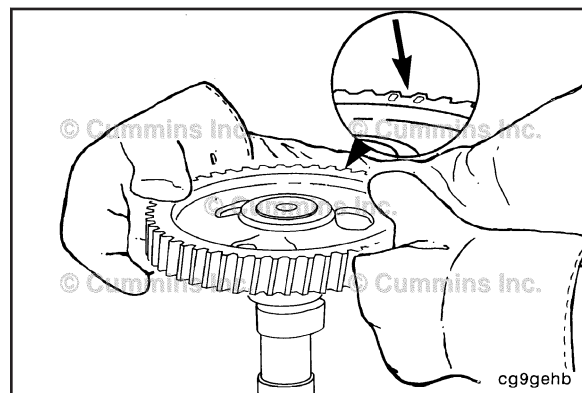

Using the camshaft gear removal and installation tool, Part Number 3823589.



NOTE: Install the camshaft gear with the timing marks away from the camshaft.

Install the camshaft gear onto the nose of the camshaft. Align the camshaft gear keyway with the camshaft locating key/dowel pin.

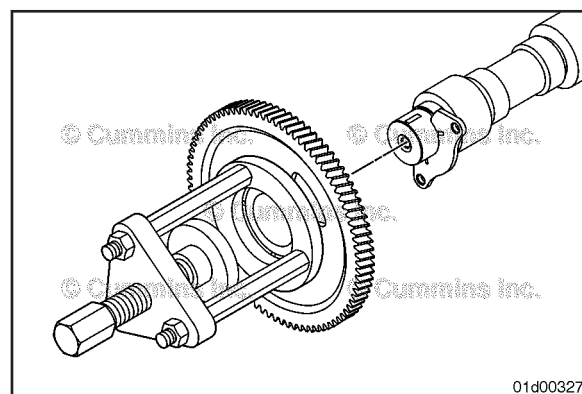

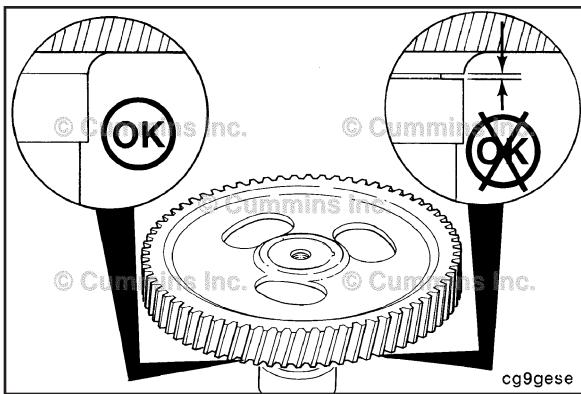

⚠ CAUTION ⚠

Make sure the gear is seated against camshaft shoulder.

Use a 0.025 mm [0.001 inch] feeler gauge to see if the feeler gauge can be inserted between the camshaft gear and the shoulder on the camshaft. If the feeler gauge can be inserted, the camshaft gear is **not** properly seated.

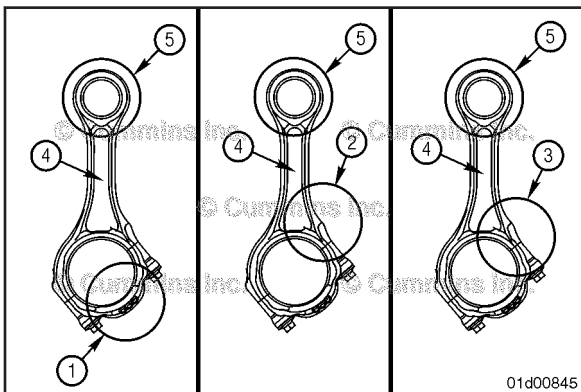

Connecting Rod (001-014)

General Information

Different types of connecting rods are used in B series engines, depending on the producing plant and when the engine was built. **Not** all connecting rods are interchangeable. When replacing a connecting rod, use the following procedure for connecting rod identification and interchangeability. Refer to Procedure 001-999 in Section F.

Not all connecting rods have the part number located on the connecting rod. It may be necessary to identify physical characteristics of the connecting rod when matching it to existing connecting rods.

- 1 Balance weight on the connecting rod cap
- 2 Protrusion on short side of connecting rod
- 3 Smooth edge on short side of connecting rod
- 4 I-Beam Design
- 5 Oil grooves and thickness of connecting rod bushing.

Preparatory Steps

⚠️ WARNING ⚠️

Batteries can emit explosive gases. To reduce the possibility of personal injury, always ventilate the compartment before servicing the batteries. To reduce the possibility of arcing, remove the negative (-) battery cable first and attach the negative (-) battery cable last.

⚠️ WARNING ⚠️

Coolant is toxic. Keep away from pets and children. If not reused, dispose of in accordance with local environmental regulations.

⚠️ WARNING ⚠️

Wait until the temperature is below 50°C [120°F] to reduce the possibility of personal injury from hot coolant.

⚠️ WARNING ⚠️

Some state and federal agencies have determined that used engine oil can be carcinogenic and cause reproductive toxicity. Avoid inhalation of vapors, ingestion, and prolonged contact with used engine oil. If not reused, dispose of in accordance with local environmental regulations.

⚠️ WARNING ⚠️

To reduce the possibility of personal injury, avoid direct contact of hot oil with your skin.

- Disconnect the batteries. Refer to the OEM service manual.
- Drain the coolant. Refer to Procedure 008-018 in Section 8.
- Remove the cylinder head. Refer to Procedure 002-004 in Section 2.
- Drain the lubricating oil. Refer to Procedure 007-037 in Section 7.
- Remove the lubricating oil pan and gasket. Refer to Procedure 007-025 in Section 7.
- Remove the lubricating oil suction tube. Refer to Procedure 007-035 in Section 7.
- Remove the block stiffener plate. Refer to Procedure 001-089 in Section 1.
- Remove the J-jet piston cooling nozzles (if equipped) to prevent damage during connecting rod removal. Refer to Procedure Procedure 001-046 in Section 1.
- Remove the piston and connecting rod assemblies from the engine. Refer to Procedure 001-054.
- Disassemble the pistons from the connecting rods. Refer to Procedure 001-054 in Section 1.

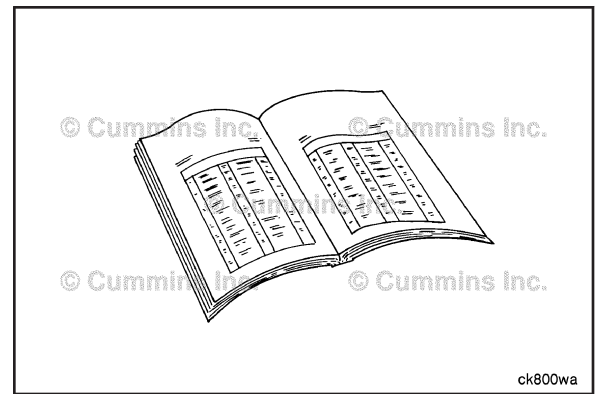

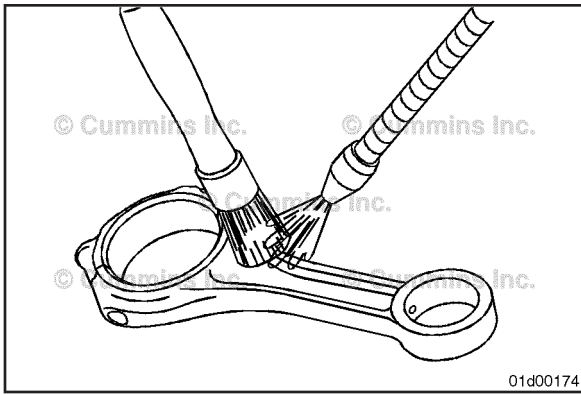

Clean and Inspect for Reuse

⚠ WARNING ⚠

When using solvents, acids, or alkaline materials for cleaning, follow the manufacturer's recommendations for use. Wear goggles and protective clothing to reduce the possibility of personal injury.

⚠ WARNING ⚠

Compressed air used for cleaning should not exceed 207 kPa [30 psi]. Use only with protective clothing, goggles/shield, and gloves.

⚠ CAUTION ⚠

The contact surface between the connecting rod and connecting rod cap is not a machined surface. Care should be exercised so these parts are not damaged during handling.

Use solvent to clean the connecting rods.

NOTE: Unless cleaning the contact surface between the connecting rod and connecting rod cap, the rod and cap should be assembled together with the bolts tightened finger tight to prevent damage to the mating surfaces.

Use solvent and a nylon bristle brush to clean the contact surface between the connecting rod and connecting rod cap. Dry the contact surface with compressed air.

Dry the connecting rods with compressed air.

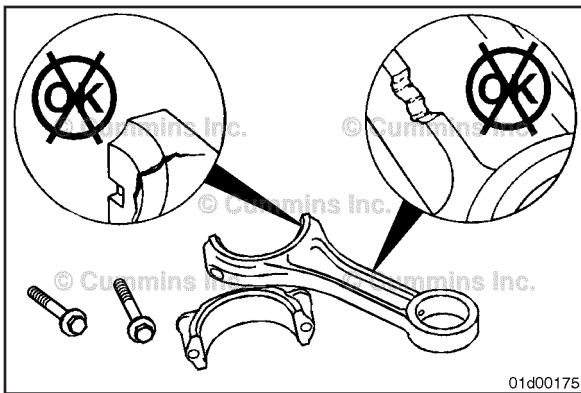

⚠ CAUTION ⚠

The connecting rod and rod cap must be replaced as an assembly if any fretting damage is visible on either piece.

Inspect the rod caps, connecting rod bearing saddles, and capscrews for nicks, cracks, burrs, scratches, and frets.

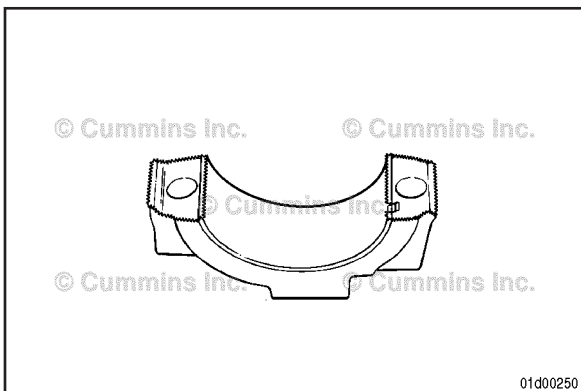

NOTE: The contact surface between the connecting rod and the connecting rod cap is **not** a machined surface. This surface should **not** be considered damaged unless there are deep nicks or cracks across the surface.

Inspect the contact surface between the connecting rod and the connecting rod cap.

Inspect the connecting rod piston pin bore for damage.

NOTE: The connecting rod small end bore does **not** have an oil drilling that lines up with the hole in the bushing. The hole in the bushing is for manufacturing purposes only.

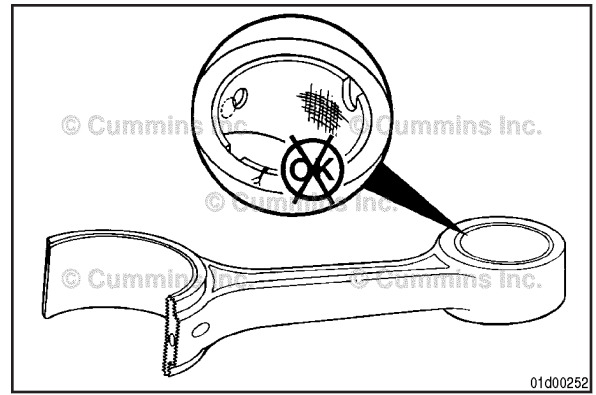

Measure the connecting rod piston pin bushing inside diameter.

Connecting Rod Piston Pin Bushing Diameter

mm		in
40.019	MIN	1.5756
40.042	MAX	1.5765

If the bushing is found to be damaged or out of specification, the bushing can be replaced. Use service tool Part Number 3823902 to remove and install the bushing.

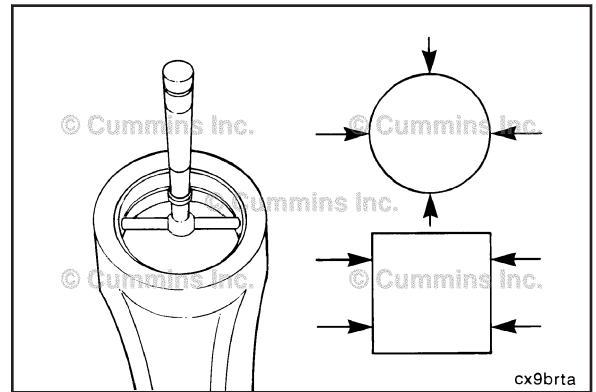

CAUTION

Use a vise with brass jaws to hold the connecting rod. Notches, scratches, or dents in the I-beam area can cause engine damage.

CAUTION

The number on the connecting rod must be the same as the number on the rod cap. Connecting rods and caps are manufactured as an assembly and cannot be interchanged. Engine damage can result.

Use clean 15W-40 engine oil to lubricate the connecting rod capscrews.

Assemble the connecting rod, rod cap, and capscrews.

Tighten the capscrews.

Torque Value: 100 N•m [74 ft-lb]

Use a dial bore indicator to measure the inside diameter within a 20-degree arc from each side of the parting line.

Measure the inside diameter at 90 degrees from the parting line.

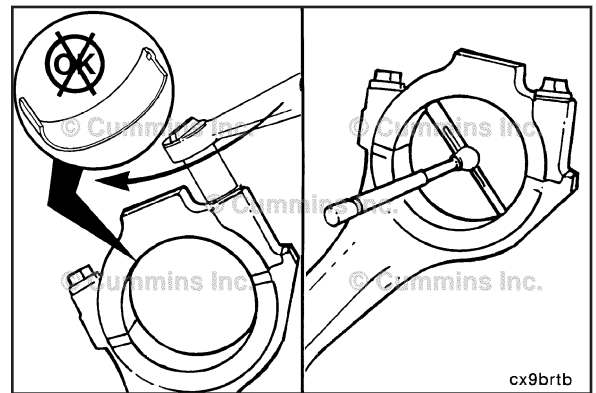

Connecting Rod Crankshaft Bore Diameter Bearings Removed

mm		in
72.99	MIN	2.873
73.01	MAX	2.875

NOTE: If the connecting rod crankshaft bore measurements are **not** within specifications, the connecting rod **must** be replaced.

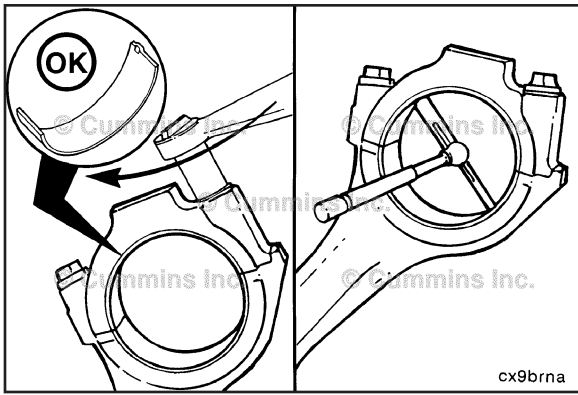

Repeat the above inspection with the connecting rod bearings installed.

Standard Connecting Rod Crankshaft Bore Diameter with Bearings Installed

	mm		in
Standard	69.05	MIN	2.719
	69.10	MAX	2.720

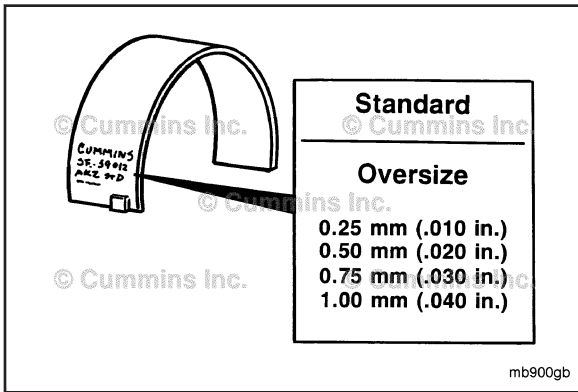

Oversize Connecting Rod Crankshaft Bore Diameter with Bearings Installed

	mm		in
Oversize	68.80	MIN	2.709
	68.85	MAX	2.711
0.25 mm [0.010 in]	68.55	MIN	2.699
	68.60	MAX	2.701
0.50 mm [0.020 in]	68.30	MIN	2.689
	68.35	MAX	2.691
0.75 mm [0.030 in]	68.05	MIN	2.680
	68.10	MAX	2.681

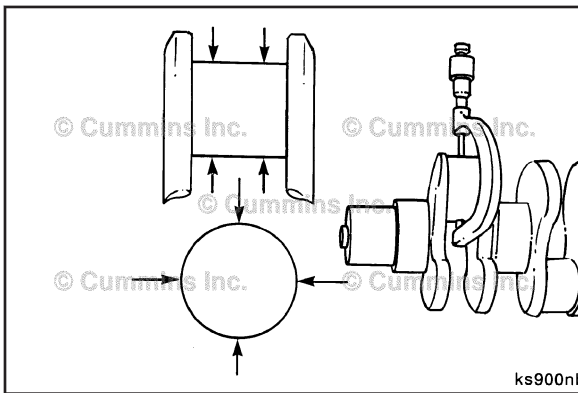

Measure the diameter of the connecting rod journal on the crankshaft.

Standard Crankshaft Connecting Rod Journal Diameter

	mm		in
Standard	68.962	MIN	2.7150
	69.013	MAX	2.7170

Undersize Crankshaft Connecting Rod Journal Diameter

	mm		in
Undersize	68.712	MIN	2.7052
	68.763	MAX	2.7072
0.25 mm [0.010 in]	68.462	MIN	2.6954
	68.513	MAX	2.6974
0.50 mm [0.020 in]	68.212	MIN	2.6855
	68.263	MAX	2.6875
0.75 mm [0.030 in]	67.962	MIN	2.6767
	68.013	MAX	2.6787

NOTE: If crankshaft connecting rod journals are **not** within the given specifications, the crankshaft **must** be reground.

Bearing clearance equals the connecting rod crankshaft bore (with bearing) minus the crankshaft connecting rod journal diameter.

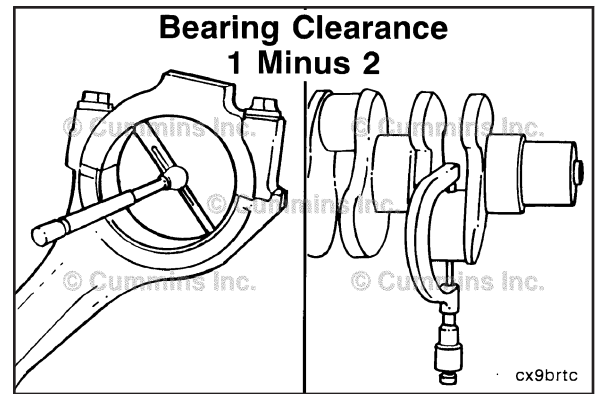
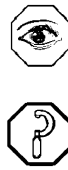

Connecting Rod to Crankshaft Bearing Clearance		
mm		in
0.04	MIN	0.002
0.12	MAX	0.005

Bearing clearance can also be determined with a plastigauge during engine assembly.



NOTE: If the clearance is found to be out of specification, replace or try another set of connecting rod bearings.

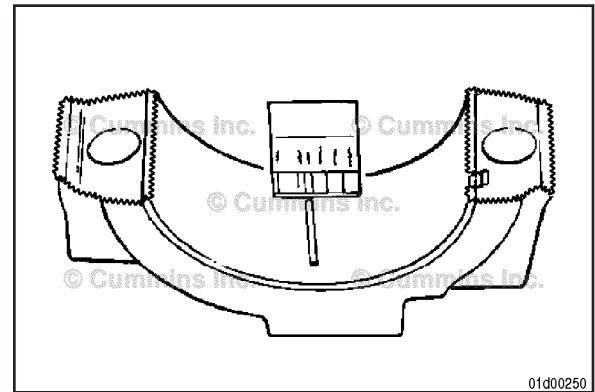

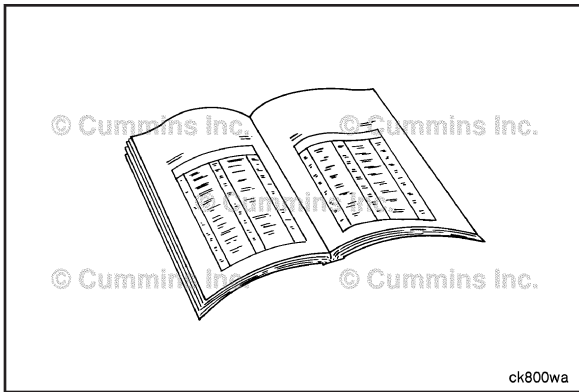

Finishing Steps

⚠ WARNING ⚠



Batteries can emit explosive gases. To reduce the possibility of personal injury, always ventilate the compartment before servicing the batteries. To reduce the possibility of arcing, remove the negative (-) battery cable first and attach the negative (-) battery cable last.

- Install the pistons on the connecting rods. Refer to Procedure 001-054 in Section 1.
- Install the pistons and connecting rod assembly. Refer to Procedure 001-054 in Section 1.
- Install the J-jet piston cooling nozzles (if equipped). Refer to Procedure 001-046
- Install the block stiffener plate. Refer to Procedure 001-089 in Section 1.
- Install the lubricating oil suction tube. Refer to Procedure 007-035 in Section 7.
- Install the lubricating oil pan and gasket. Refer to Procedure 007-025 in Section 7.
- Install the cylinder head. Refer to Procedure 002-004 in Section 2.
- Fill the lubricating oil pan. Refer to Procedure 007-037 in Section 7.
- Fill the cooling system. Refer to Procedure 008-018 in Section 8.
- Connect the batteries. Refer to the OEM service manual.
- Operate the engine to normal operating temperature and check for leaks.

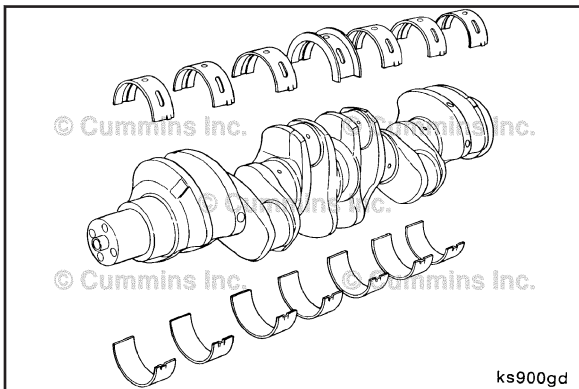

Crankshaft (001-016)

General Information

The crankshaft uses forged counterweights.

Oversize main bearings, thrust bearings, and connecting rod bearings are available for service. Cummins Inc. recommends regrinding all the main or connecting rod journals when one requires regrinding. See the appropriate parts catalog.

Preparatory Steps



The engine lifting equipment must be designed to lift the engine and transmission as an assembly without causing personal injury.



This component or assembly weighs greater than 23 kg [50 lb]. To prevent serious personal injury, be sure to have assistance or use appropriate lifting equipment to lift this component or assembly.



To reduce the possibility of personal injury, avoid direct contact of hot oil with the skin.



Some state and federal agencies have determined that used engine oil can be carcinogenic and cause reproductive toxicity. Avoid inhalation of vapors, ingestion, and prolonged contact with used engine oil. If not reused, dispose of in accordance with local environmental regulations.



Batteries can emit explosive gases. To reduce the possibility of personal injury, always ventilate the compartment before servicing the batteries. To reduce the possibility of arcing, remove the negative (-) battery cable first and attach the negative (-) battery cable last.

- Disconnect the batteries. Refer to the original equipment manufacturer (OEM) service manual.
- Drain the lubricating oil. Refer to Procedure 007-037 in Section 7.
- Remove the engine and place it on an engine stand. Refer to Procedure 000-001 in Section 0.
- If equipped, remove the belt guards. Refer to Procedure 008-001 in Section 8.
- For Marine applications, remove the sea water pump drive belt. Refer to Procedure 008-127 in Section 8.
- Remove the cooling fan drive belt. Refer to Procedure 008-002 in Section 8.
- If required, remove the fan hub pulley. Refer to Procedure 008-039 in Section 8.
- Remove the vibration damper/crankshaft speed indicator ring.
- If equipped, remove the viscous damper. Refer to Procedure 001-052 in Section 1.
- If equipped, remove the rubber damper. Refer to Procedure 001-051 in Section 1.
- If equipped, remove the crankshaft speed indicator ring **only**. Refer to Procedure 001-071 Section 1.
- Remove the front cover. Refer to Procedure 001-031 in Section 1.
- Remove the flywheel or flexplate. Refer to Procedure 016-005 in Section 16.
- Remove the flexplate. Refer to Procedure 016-004 in Section 16.
- Remove the flywheel housing. Refer to Procedure 016-006 in Section 16.
- For front gear train engines, remove the rear seal and rear seal carrier. Refer to Procedure 001-024 in Section 1.
- For rear gear train engines, remove the camshaft gear. Refer to Procedure 001-012 in Section 1.
- Remove the lubricating oil pan. Refer to Procedure 007-025 in Section 7.
- If equipped, remove the balancer. Refer to Procedure 001-004 in Section 1.
- Remove the block stiffener plate. Refer to Procedure 001-089 in Section 1.
- Remove the lubricating oil suction tube. Refer to Procedure 007-035 in Section 7.
- Remove the fuel pump and gear. Refer to Procedure 005-016 in Section 5.
- If equipped, remove or disconnect any driven accessories (i.e., hydraulic pump).
- If equipped, remove the air compressor. Refer to Procedure 012-014 in Section 12.
- For rear gear train engines, remove the rear gear housing. Refer to Procedure 001-034 in Section 1.
- For front gear train engines, remove the front gear housing. Refer to Procedure 001-033 in Section 1.
- For front gear train engines, remove the rear seal and rear seal carrier. Refer to Procedure 001-067 in Section 1.
- Remove the connecting rod caps. Refer to Procedure 001-005 in Section 1.

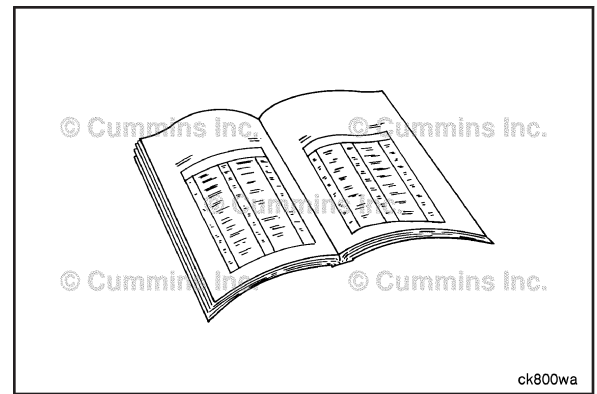

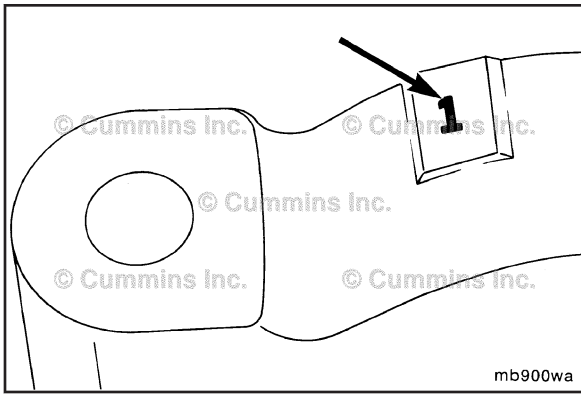

Remove

Before removing the main bearing caps, make certain that the caps are clearly marked for their location on the lubricating oil cooler side of the main bearing cap and cylinder block.

The number 1 cap is at the front of the engine.

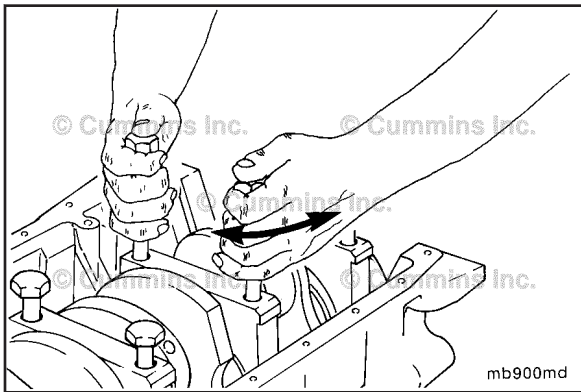

Loosen the main bearing capscrews completely, but do **not** remove.

⚠ CAUTION ⚠

Do not pry on the main bearing caps to free them from the cylinder block. Damage to the main bearing caps and cylinder block can result.

Use two of the main bearing cap bolts to “wobble” the main bearing cap loose, being careful **not** to damage the bolt threads.

Remove the main bearing cap.

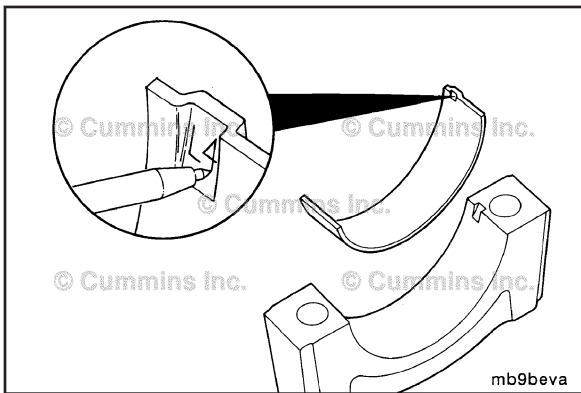

Mark the lower main bearings for position and number as they are removed.

Use an awl to mark the bearing position in the tang area.

NOTE: Mark the bearing's position for future identification or possible failure analysis.

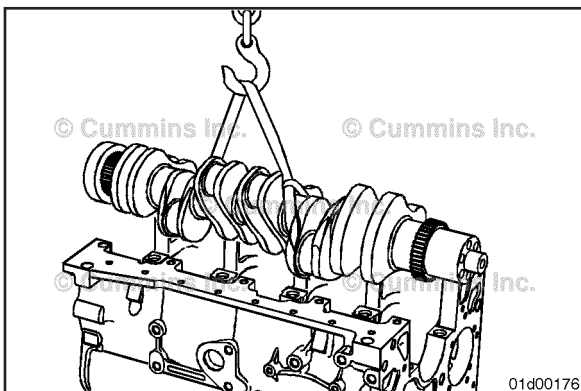

⚠ WARNING ⚠

This component or assembly weighs greater than 23 kg [50 lb]. To prevent serious personal injury, be sure to have assistance or use appropriate lifting equipment to lift this component or assembly.



NOTE: Lift the crankshaft straight up to avoid damage to the crankshaft and cylinder block.

For 6 cylinder engines, install the nylon lift sling, Part Number 3375957, around the number 3 and number 4 rod bearing journals.

For 4 cylinder engines, install the nylon lift sling, Part Number 3375957, around the number 2 and number 3 rod bearing journals.

Attach the sling to a hoist and remove the crankshaft.

Remove the upper main bearings.

Use an awl to mark the bearing's position in the tang area.

NOTE: Mark the bearing's position for future identification or possible failure analysis.

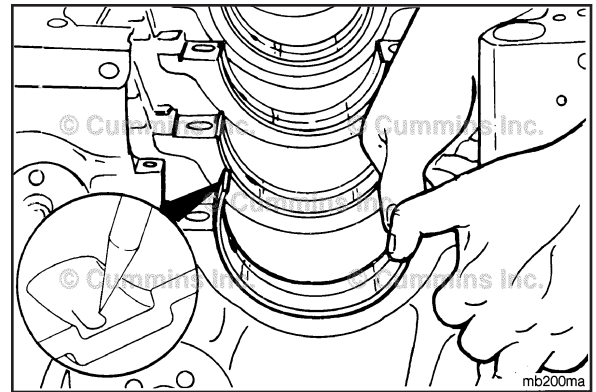

Clean and Inspect for Reuse

⚠️ WARNING ⚠️

When using a steam cleaner, wear safety glasses or a face shield, as well as protective clothing. Hot steam can cause serious personal injury.

⚠️ WARNING ⚠️

Wear appropriate eye and face protection when using compressed air. Flying debris and dirt can cause personal injury.

Steam clean or use hot, soapy water to clean the crankshaft and gear(s).

Use a non-metallic bristle brush to clean the oil drillings. Dry with compressed air. Make sure to blow out the threaded holes on each end of the crankshaft and the oil drillings.

Use a fine crocus cloth to polish the machined surfaces.

Use a bristle brush to clean the oil drillings.

Inspect the front crankshaft gear. Refer to Procedure 001-019 in Section 1.

Inspect the connecting rod bearings. Refer to Procedure 001-005 in Section 1.

Inspect the main bearings. Refer to Procedure 001-006 in Section 1.

NOTE: Inspect the crankshaft gear for pitting, fretting, or missing teeth. The rear crankshaft gear is **not** replaceable. If fretting can **not** be removed using abrasive pad, Part Number 3823258, or equivalent, the crankshaft **must** be replaced.

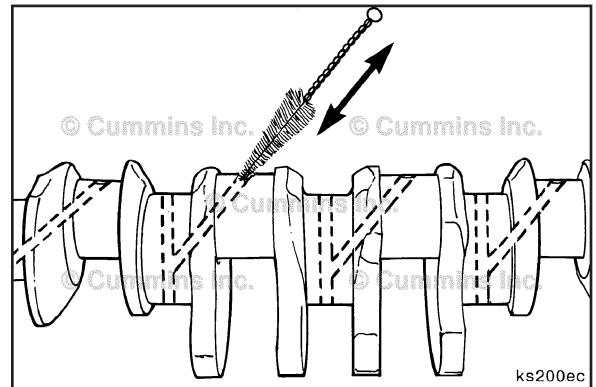
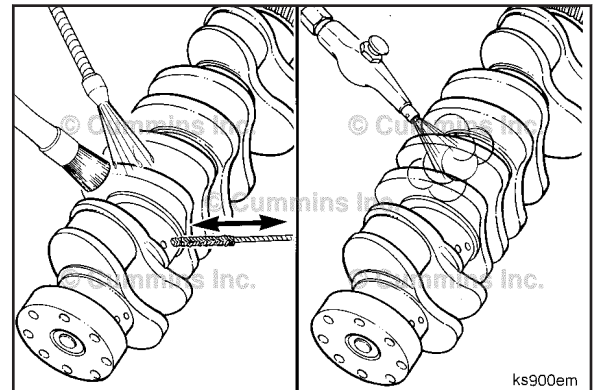

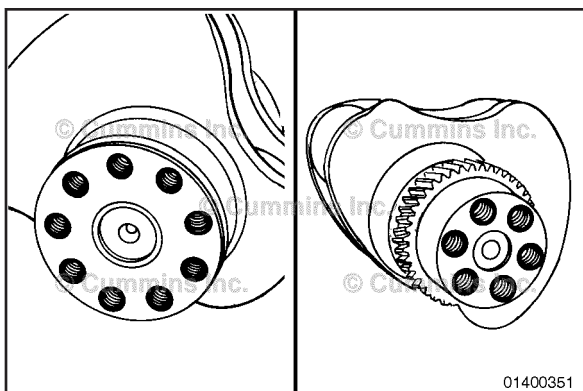

⚠ CAUTION ⚠

Do not chase threads on the crankshaft. Severe engine damage can occur.



Check the threads for damage at both ends of the crankshaft.

If damage is found, replace the crankshaft.

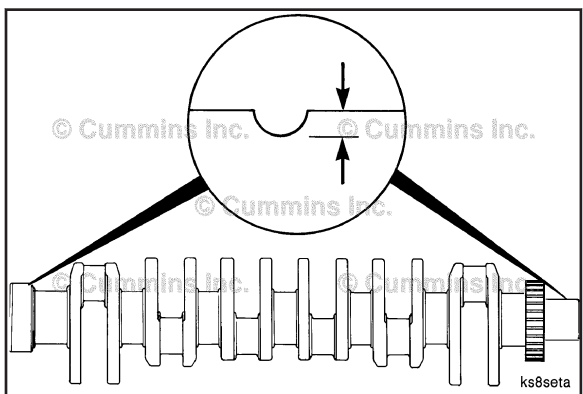

Measure the front and rear oil seal contact areas for a wear groove.



Crankshaft Front and Rear Oil Seal Wear Groove

mm		in
0.25	MAX	0.010

A front wear sleeve is available for a crankshaft that is worn beyond the limit. Refer to Procedure 001-023 in Section 1.

NOTE: For 4.5L and 6.7L engines, the front crankshaft seal wear surface is part of the seal, therefore, the front of the crankshaft does **not** need to be inspected for wear.

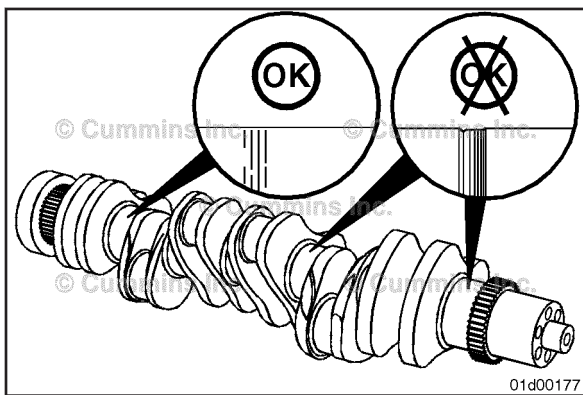

Check the main bearing journals and the rod bearing journals for damage or excessive wear. Minor scratches are acceptable.

Measure

Measure the crankshaft main and connecting rod journals.

Out-of-Round: 0.050 mm [0.002 in].

Taper: 0.013 mm [0.0005 in].

NOTE: If crankshaft journals are **not** within the given specification, the crankshaft **must** be reground. **Always** grind all the journals when one is **not** within specifications.

Measure and record the diameter of the connecting rod journal on the crankshaft.

Standard Crankshaft Connecting Rod Journal Diameter

	mm		in	
Standard	68.987	MIN	2.7160	
	69.027	MAX	2.7176	

Undersize Crankshaft Connecting Rod Journal Diameter

	mm		in	
Undersize				
0.25 mm [0.010 in]	68.712	MIN	2.7052	
	68.774	MAX	2.7076	
0.50 mm [0.020 in]	68.462	MIN	2.6954	
	68.527	MAX	2.6979	
0.75 mm [0.030 in]	68.212	MIN	2.6855	
	68.274	MAX	2.6879	
1.00 mm [0.040 in]	67.962	MIN	2.6767	
	68.027	MAX	2.6782	

NOTE: If the crankshaft connecting rod journals are **not** within the given specification, the crankshaft **must** be reground. Select the target undersize journal diameter and its corresponding oversize bearing. Machine the crankshaft to the maximum journal diameter specified in the table above. Then finish the crankshaft to the target diameter. **Always** grind all of the journals when one is **not** within specifications.

Measure and record the diameter of the connecting rod crankshaft bore with the bearings installed. Refer to Procedure 001-014 in Section 1 for measuring the connecting rod crankshaft bore (with bearing).

Calculate the connecting rod bearing-to-crankshaft journal clearance.

Bearing clearance equals the connecting rod crankshaft bore (with bearing) minus the crankshaft connecting rod journal diameter.

Connecting Rod to Crankshaft Bearing Clearance

mm	in	
0.04	MIN	0.002
0.12	MAX	0.005

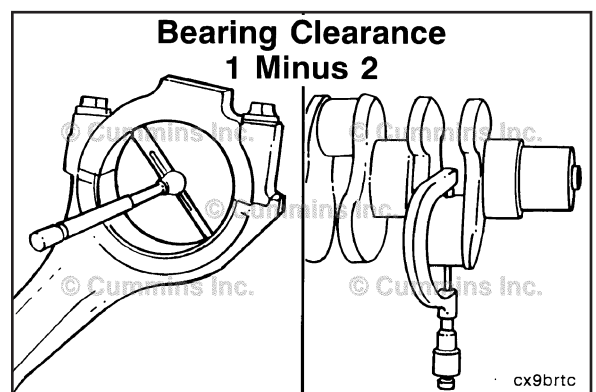
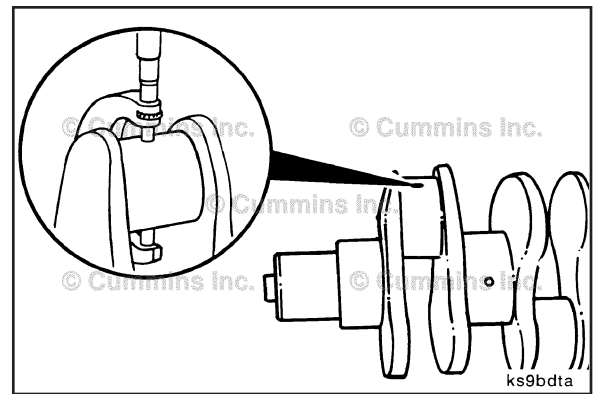
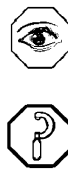

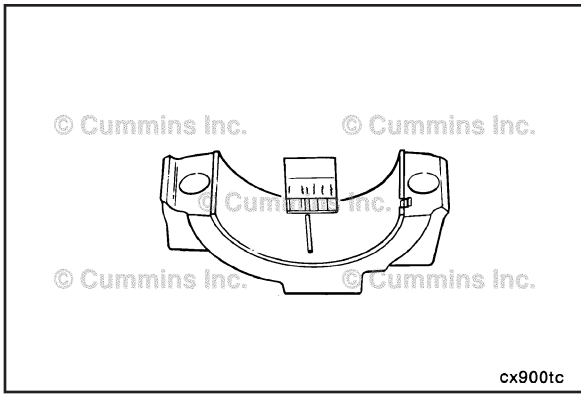

Bearing clearance can also be determined with a plastigauge during crankshaft installation.

NOTE: If the clearance is found to be out of specification:



- 1 Replace or try another set of connecting rod bearings
- 2 Measure and inspect the connecting rod crankshaft bore with the bearings removed. Refer to Procedure 001-014 in Section 1.

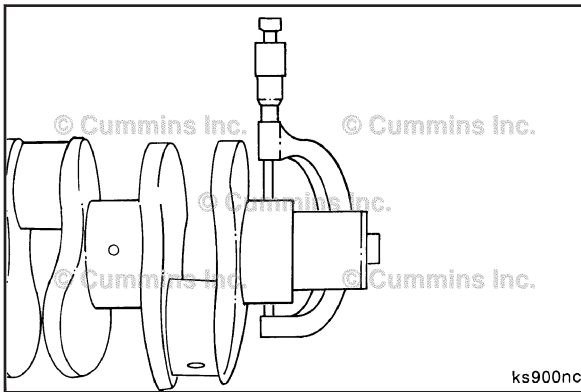

Measure and record the diameter of the main bearing journal on the crankshaft.



Standard Crankshaft Main Bearing Journal Diameter

	mm		in
Standard	82.962	MIN	3.2662
	83.013	MAX	3.2682

Undersize Crankshaft Main Bearing Journal Diameter

	mm		in
Undersize	0.25 mm [0.010 in]	MIN	3.2564
		MAX	3.2584
0.50 mm [0.020 in]	82.462	MIN	3.2465
	82.513	MAX	3.2485
0.75 mm [0.030 in]	82.212	MIN	3.2367
	82.263	MAX	3.2387
1.0 mm [0.040 in]	81.962	MIN	3.2268
	82.013	MAX	3.2289

NOTE: If the crankshaft main bearing journals are **not** within the given specifications, the crankshaft **must** be reground. **Always** grind all the journals when one is **not** within specifications. Oversize main bearings are available; see the appropriate parts catalog.

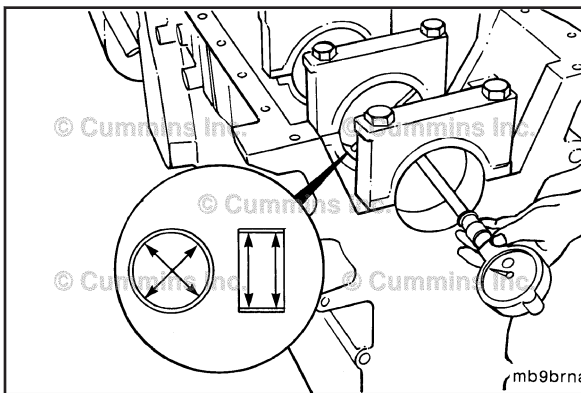

Install the main bearing caps with the upper and lower main bearings. Refer to Procedure 001-006 (Bearings, Main) in Section 1 for main bearing cap installation.



Tighten the main bearing cap capscrews.

Torque Value: 176 N•m [130 ft-lb]



Measure the main bearing bore with the bearings installed.

Calculate the main bearing to crankshaft journal clearance.

Bearing clearance equals the main bearing crankshaft bore (with bearing) minus the crankshaft main bearing journal diameter.

Main Bearing Bore to Crankshaft Bearing Clearance

mm		in
0.04	MIN	0.002
0.12	MAX	0.005

Bearing clearance can also be determined with a plastigauge during engine assembly.

NOTE: If the clearance is found to be out of specification:

- 1 Replace or try another set of main bearings
- 2 Measure and inspect the main bearing bore with the bearings removed. Refer to Procedure 001-026 in Section 1.

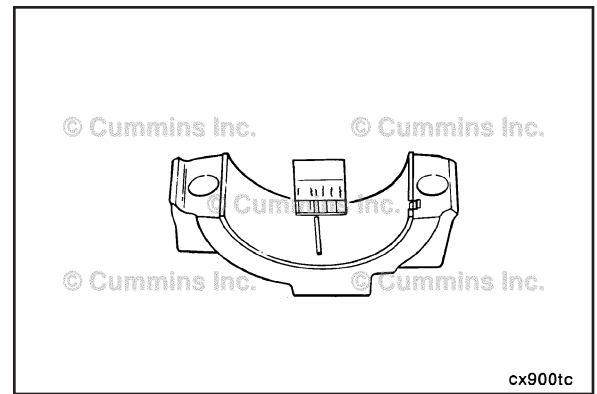

Main Bearing Capscrew Reuse Measurement

⚠CAUTION⚠

This step must be completed on 4.5L and 6.7L engines. Failure to check the main bearing capscrew against reuse guidelines can result in severe engine damage.

To check if a main bearing capscrew can be reused, the length **must** be measured by performing the following:

For each main bearing capscrew that has been removed, measure the length from underneath the head of the capscrew to the tip of the capscrew, as illustrated, using one of two methods.

- 1 A depth micrometer (preferred method for accuracy)
- 2 A machinist's rule.

If the measurement is above the maximum specification, the main bearing capscrew **must** be replaced.

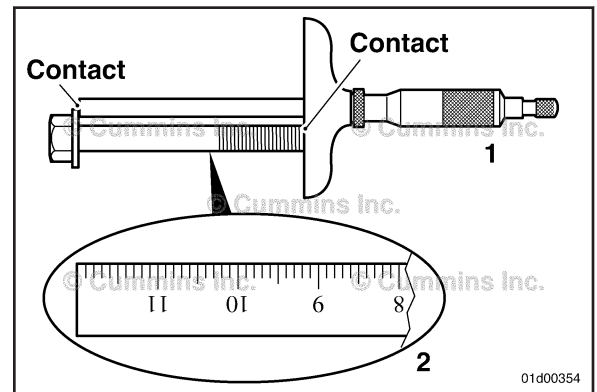

Main Bearing Underhead Capscrew Length

mm		in
120.00	MAX	4.724

Measure the thrust face width. Minor scratches are acceptable. Use a fine crocus cloth to polish the machined surfaces.

The thrust bearing surfaces are located at:

For 4 cylinder engines - The number 4 crankshaft main bearing journal.

For 6 cylinder engines - The number 6 crankshaft main bearing journal.

Crankshaft Thrust Face Width (Standard)

mm		in
37.48	MIN	1.475
37.55	MAX	1.478

NOTE: Oversize thrust bearings are available if the thrust distance is **not** within specifications. See the appropriate parts catalog.

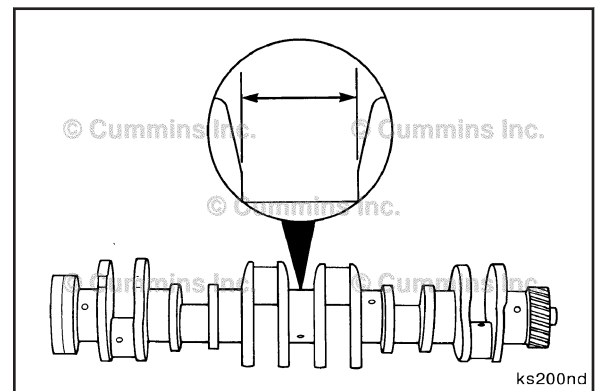

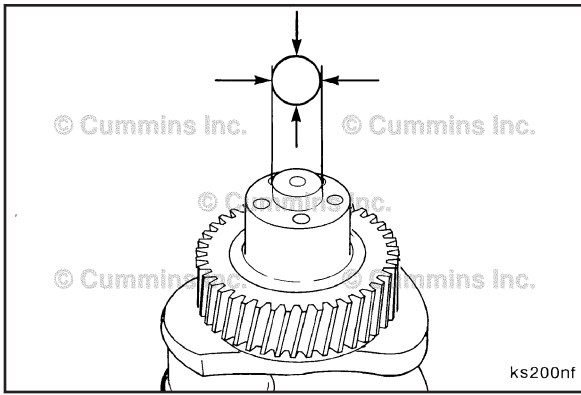

Measure the damper pilot outside diameter.

Crankshaft Damper Pilot Outside Diameter

mm		in
24.92	MIN	0.981
25.00	MAX	0.984

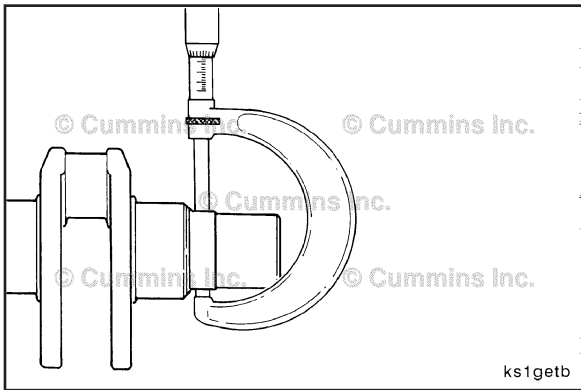

Measure the crankshaft gear journal outside diameter.

Crankshaft Gear Journal Outside Diameter

mm		in
70.59	MIN	2.779
70.61	MAX	2.780

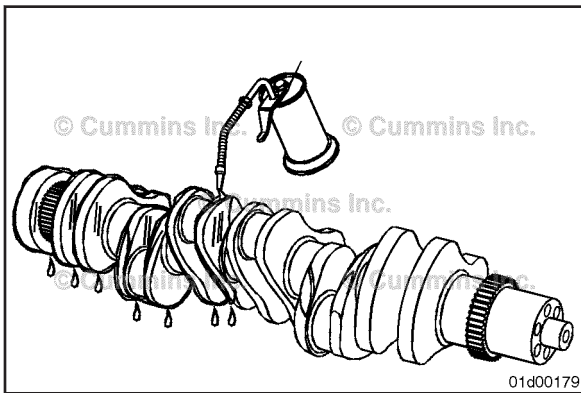

Use a light preservative oil to lubricate the crankshaft to prevent rust.

NOTE: If the crankshaft is **not** going to be used immediately, use a **heavy** preservative oil. Protect the crankshaft with a cover to prevent dirt from sticking to the oil.

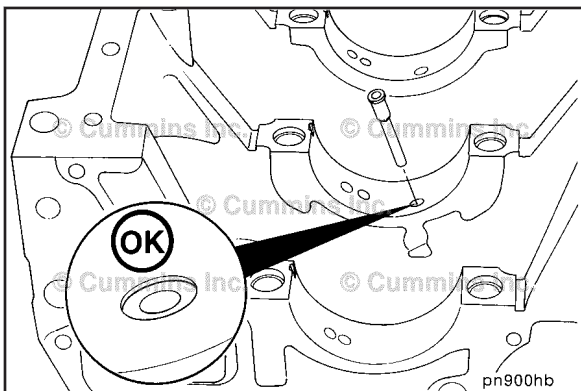

Initial Check

For engines equipped with drillings for saddle jet piston cooling nozzles/plugs, verify that:

For engines originally equipped with saddle jet piston cooling nozzles, the piston cooling nozzles are installed and free from debris/damage.

Or

For engines equipped with J-jet piston cooling nozzles, the saddle jet piston cooling nozzle drillings are plugged.

NOTE: Some engines do **not** contain drillings for saddle jet piston cooling nozzles/plugs.

Install

⚠CAUTION⚠

The tang (1) on the bearing shell must be in the slot (2) of the bearing saddle to correctly position the bearing and prevent engine damage.

Upper Main Bearings.

Make sure the backs of the bearings are clean and free of debris before installing the upper main bearings into the block.

Do **not** lubricate the side of the main bearing that is against the cylinder block.

Apply a coat of assembly lubricant, Part Number 3163087 or equivalent, to the crankshaft side of the upper main bearings.

NOTE: Make sure the main bearing being installed is the same size as the main bearing that was removed. The size is engraved on the back of the main bearing.

NOTE: The upper and lower main bearing shells of some engines are **not** interchangeable. The backs of the main bearings are **not** marked with the proper orientation, if required.

NOTE: If used bearing shells are to be installed, they **must** be installed in their original locations, as marked during disassembly.

Install the upper crankshaft thrust bearing.

4 cylinder engines - The number 4 main bearing position.

6 cylinder engines - The number 6 main bearing position.

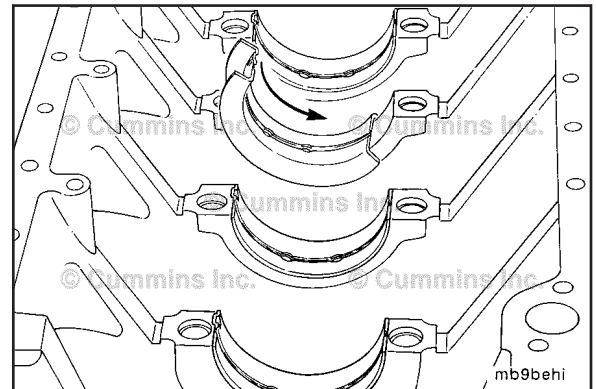
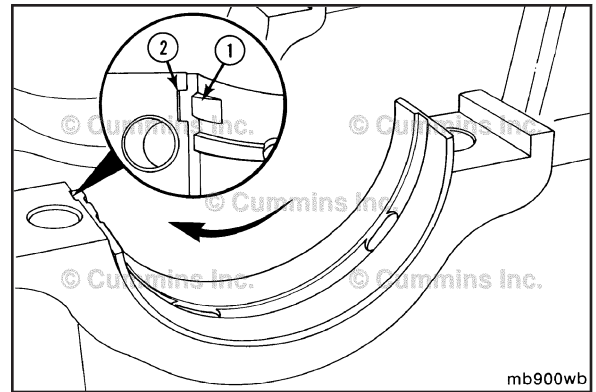

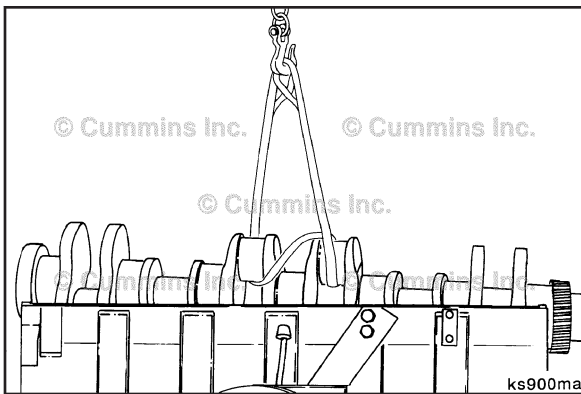

▲ WARNING ▲
This component or assembly weighs greater than 23 kg [50 lb]. To prevent serious personal injury, be sure to have assistance or use appropriate lifting equipment to lift this component or assembly.

▲ WARNING ▲
Carefully install the crankshaft to avoid damage to the crankshaft main bearings, especially the thrust/main bearing journals. Engine life will be shortened if damage to the crankshaft occurs.

Use a hoist and nylon list sling, Part Number 3375957.

For 6 cylinder engines, Install the sling around the number 3 and number 4 connecting rod bearing journals.

For 4 cylinder engines, Install the sling around the number 2 and number 3 connecting rod bearing journals.

Install the crankshaft.

NOTE: Lower the crankshaft straight down to avoid damage to the crankshaft and cylinder block.

NOTE: When setting the crankshaft into the block, make sure the front crankshaft gear meshes with the lubricating oil pump gear, if **not** previously removed.

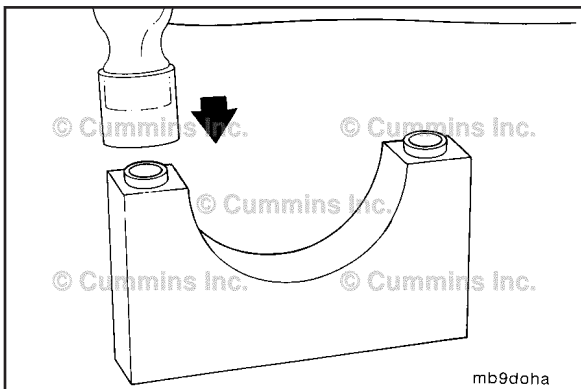

Check the main bearing caps to make sure the ring dowels are installed.

⚠ CAUTION ⚠

Do not lubricate the back side of the bearing that contacts the main bearing cap.

Make sure the backside of the bearings are clean and free of debris before installing the lower main bearings into the main bearing caps.

Make sure to align the tang of the bearings with the recesses on the main bearing caps.

NOTE: Some engines use a thrust bearing for the upper and lower main bearing (360 degree), while other engines only have a thrust bearing for the upper main bearing (180 degree). **Always** use replacement bearings of the same design.

If equipped, install the lower crankshaft thrust bearing.

4 cylinder engines - The number 4 main bearing position.

6 cylinder engines - The number 6 main bearing position.

Apply a coat of assembly lube, Part Number 3163087, to the crankshaft side of the main bearings and thrust bearing surfaces.

Make sure the main bearing cap surfaces between the main bearing cap and block are clean and free of debris.

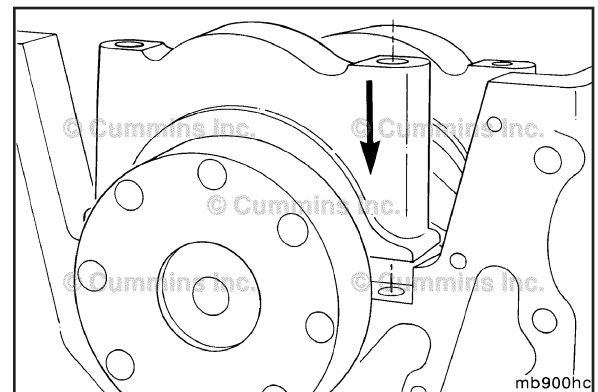
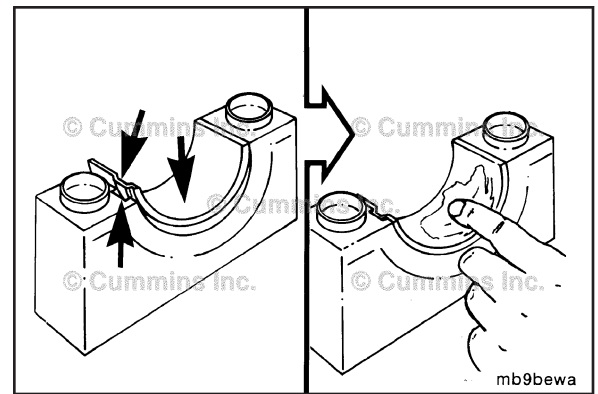

The main bearing caps are/were numbered during the removal process for their location. Number 1 starts with the front of the block.

NOTE: The caps **must** be installed so the numbers on the caps match the bearing saddle in the block. The lock tangs in the main bearing saddle and bearing cap **must** be on the same side.

Install the main bearing caps. Make sure to align the ring dowels on the main bearing cap with the corresponding drillings in the cylinder block.

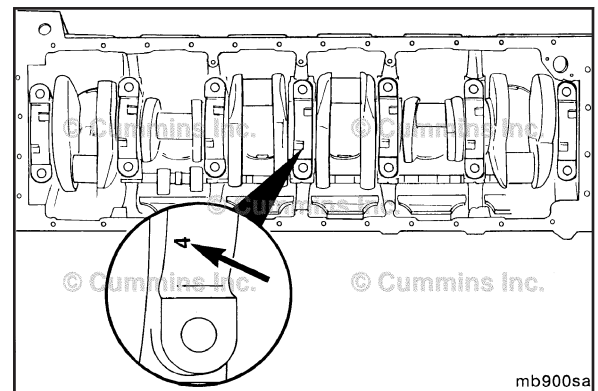

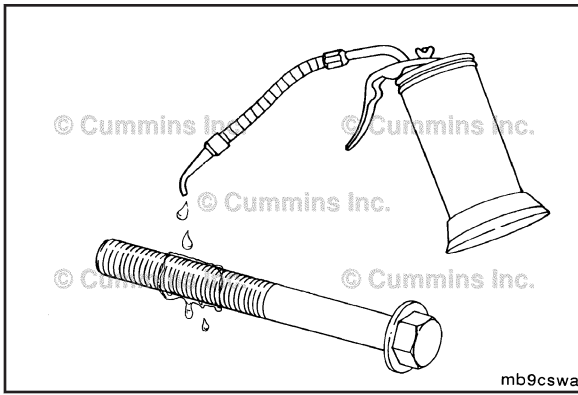

Lubricate the main bearing cap screw threads and underside of the head with clean engine oil.

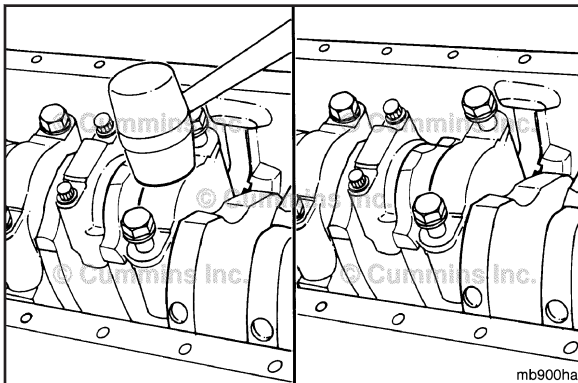

Gently tap the main bearing cap into position with a plastic or rubber mallet.

When seated, install the main bearing cap screws and tighten.



Torque Value: 50 N•m [37 ft-lb]

Do **not** tighten to the final torque value at this time. Final torque should be applied after all main bearing caps are installed.

NOTE: The sequence to the right is for a 6 cylinder engine. For a 4 cylinder engine, use the same sequence for the 5 main bearing caps.



Tighten the capscrews evenly and in sequence. Perform each step to all capscrews before performing the next step.



3.9L and 5.9L Engines:

Torque Value:

Step 1	50 N•m	[37 ft-lb]
Step 2	80 N•m	[59 ft-lb]
Step 3	Turn all capscrews through 90 degrees.	

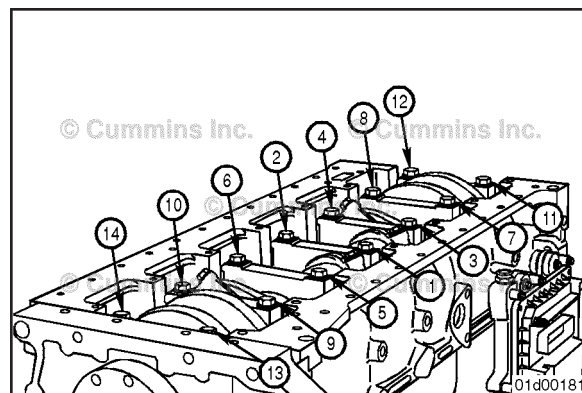

⚠ CAUTION ⚠

For 4.5L and 6.7L engines, there is a different torque procedure for new and previously installed main bearing capscrews. Failure to use the correct torque value can result in engine damage.

4.5L and 6.7L Engines:

Torque Value:

Previously Installed Main Bearing Capscrews

Step 1	50 mm	[37 in]
Step 2	60 N•m	[44 ft-lb]
Step 3	80 N•m	[59 ft-lb]
Step 4	Rotate 90 degrees.	

Torque Value:

New Main Bearing Capscrews

Step 1	50 N•m	[37 ft-lb]
Step 2	60 N•m	[44 ft-lb]
Step 3	80 N•m	[59 ft-lb]
Step 4	Rotate 90 degrees.	
Step 5	120 mm	[89 in]
Step 6	Loosen completely	
Step 7	60 mm	[44 in]
Step 8	85 mm	[63 in]
Step 9	Rotate 120 degrees.	

The crankshaft **must** rotate freely after installing the main bearing caps.



If the crankshaft does **not** rotate freely:

- 1 Check if the crankshaft is contacting one of the connecting rods
- 2 Check if the correct main bearing caps were installed correctly
- 3 Check if the main bearing cap ring dowels or mounting surfaces were damaged during installation
- 4 Check if the correct main bearings were installed.

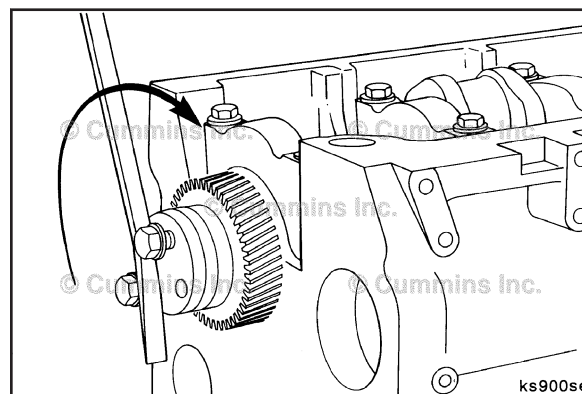

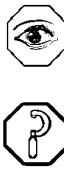
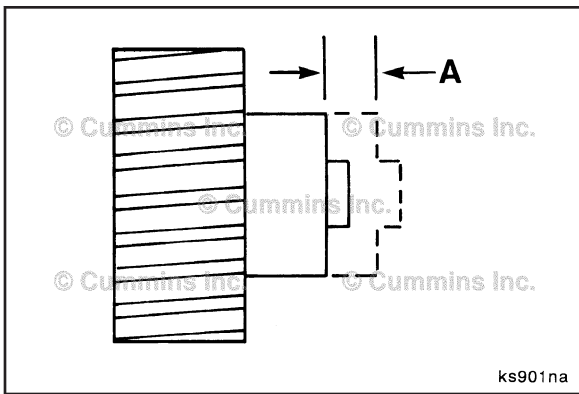

NOTE: The dimensions of the thrust bearing and crankshaft journal determine end clearance.

Measure the crankshaft end clearance with a dial indicator assembly, Part Number 3824564 and magnetic base, Part Number 3377399.

Crankshaft End Clearance

mm		in
0.102	MIN	0.004
0.432	MAX	0.017

If the crankshaft end clearance is **not** within specification:

- 1 If the crankshaft end clearance is below specification, check if there are any obstructions limiting the crankshaft's travel (lubricating oil pump, connecting rod, etc.)
- 2 If the crankshaft end clearance is above specification, inspect the crankshaft thrust bearing surface. Also check if the correct thrust bearing(s) were installed.

NOTE: Oversize thrust bearings are available if the end clearance is **not** within specifications. Oversize thrust bearings of 0.25 to 0.51 mm [0.010 to 0.020 in] are available.

Finishing Steps

⚠ WARNING ⚠

Some state and federal agencies have determined that used engine oil can be carcinogenic and cause reproductive toxicity. Avoid inhalation of vapors, ingestion, and prolonged contact with used engine oil. If not reused, dispose of in accordance with local environmental regulations.

⚠ WARNING ⚠

Batteries can emit explosive gases. To reduce the possibility of personal injury, always ventilate the compartment before servicing the batteries. To reduce the possibility of arcing, remove the negative (-) battery cable first and attach the negative (-) battery cable last.

⚠ WARNING ⚠

This component or assembly weighs greater than 23 kg [50 lb]. To prevent serious personal injury, be sure to have assistance or use appropriate lifting equipment to lift this component or assembly.

- Install the connecting rod caps. Refer to Procedure 001-005 in Section 1.
- For front gear train engines, install the front gear housing. Refer to Procedure 001-033 in Section 1.
- For rear gear train engines, install the rear gear housing. Refer to Procedure 001-034 in Section 1.
- Install the camshaft gear. Refer to Procedure 001-012 in Section 1.
- Install the fuel pump and gear. Refer to Procedure 005-016 in Section 5.
- If equipped, install the air compressor. Refer to Procedure 012-014 in Section 12.
- If equipped, install or connect any driven accessories (i.e., hydraulic pump).
- Install the lubricating oil suction tube. Refer to Procedure 007-035 in Section 7.
- Install the block stiffener plate. Refer to Procedure 001-089 in Section 1.
- If equipped, install the balancer. Refer to Procedure 001-004 in Section 1.
- Install the lubricating oil pan. Refer to Procedure 007-025 in Section 7.
- For front gear train engines, install the rear seal and rear seal carrier. Refer to Procedure 001-067 in Section 1.
- Install the flywheel. Remove the flywheel or flexplate. Refer to Procedure 016-005 in Section 16.
- Remove the flexplate. Refer to Procedure 016-004 in Section 16.
- Install the front cover. Refer to Procedure 001-031 in Section 1.
- Install the vibration damper/crankshaft speed indicator ring.
- If equipped, install the viscous damper. Refer to Procedure 001-052 in Section 1.
- If equipped, install the rubber damper. Refer to Procedure 001-051 in Section 1.
- Use the following procedure, if equipped with a crankshaft speed indicator ring **only**. Refer to Procedure 001-071 in Section 1.
- If required, install the fan hub pulley. Refer to Procedure 008-039 in Section 8.
- Install the sea water pump drive belt. Refer to Procedure 008-127 in Section 8.
- Install the cooling fan drive belt. Refer to Procedure 008-002 in Section 8.
- For Marine applications, install the sea water pump drive belt.
- If equipped, install the belt guards. Refer to Procedure 008-001 in Section 8.
- Check the engine rotation. See the Rotation Check section of this procedure located below.
- Install the engine. Refer to Procedure 000-002 in Section 0.
- Fill the lubricating oil pan with oil. Refer to Procedure 007-037 in Section 7.
- Connect the batteries. Refer to the OEM service manual.
- Check for leaks and proper engine operation.

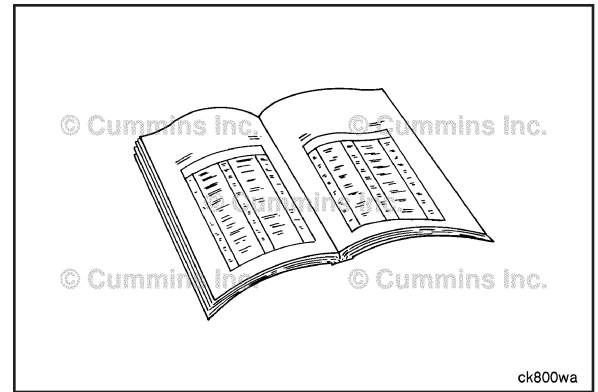

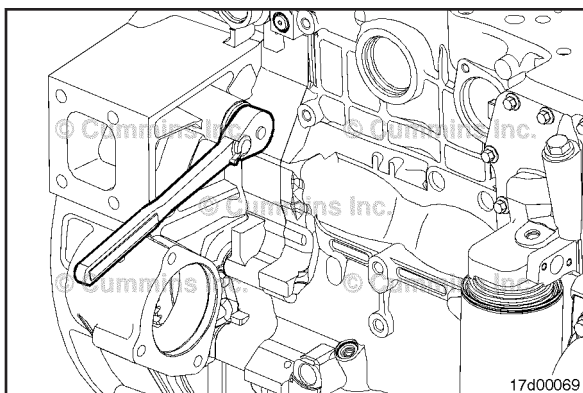

Rotation Check

With the engine fully assembled, check that the engine rotates freely. Use a barring tool, Part Number 3824591.

Insert the barring tool into the flywheel housing and engage the flywheel/flexplate ring gear. The crankshaft can then be rotated by hand. Use a 1/2- inch drive ratchet or breaker bar.

If the engine does **not** rotate freely, check for any external obstructions. (Flywheel/flexplate, engine driven accessories, etc.) If no obstructions are found, remove the oil pan and look for internal damage.

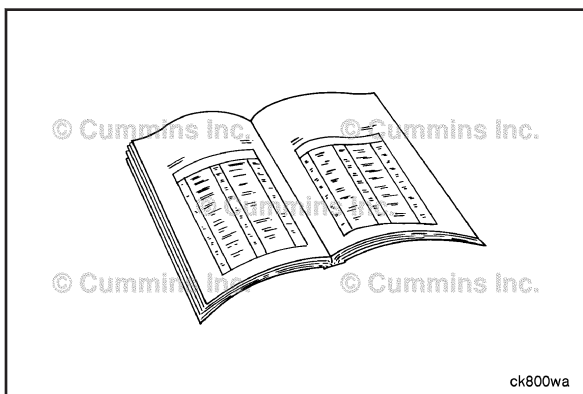

Install the engine. Refer to Procedure 000-002 in Section 0.



Fill the lubricating oil pan. Refer to Procedure 007-037 in Section 7.

On Marine applications, it is necessary to prime the fuel system before starting. Refer to Procedure 005-016 in Section 5.

Operate the engine. Check for leaks and proper engine operation.

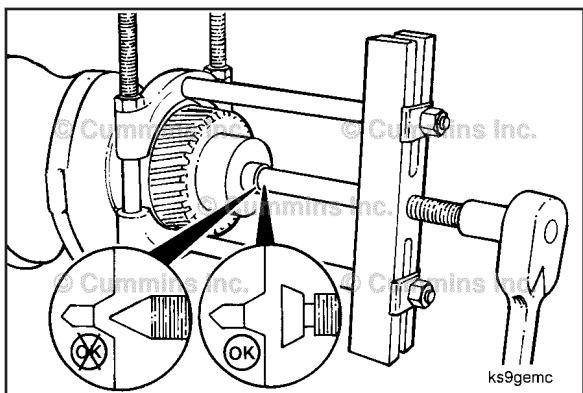

Crankshaft Gear, Front (Crankshaft Removed) (001-019)



Remove

⚠CAUTION⚠

Do not try to split the front crankshaft gear to remove. The gear is made out of steel and will not split. Damage to the tool and crankshaft can result.

NOTE: If a front crankshaft seal wear sleeve has been installed during a previous repair, it **must** be removed before removing the crankshaft gear. Refer to Procedure 001-025

Use a heavy-duty bearing separator, Part Number 3162427, or a gear puller, as illustrated, to remove the crankshaft gear.

Clean and Inspect for Reuse

Visually inspect for cracks and broken or chipped teeth.

The gear **must** be replaced if it is damaged.

NOTE: If there is damage to the front crankshaft gear teeth or there are signs of excessive heat, make sure to inspect the associated lubricating oil pump and, for front gear train engines, the fuel pump and camshaft gears for damage.

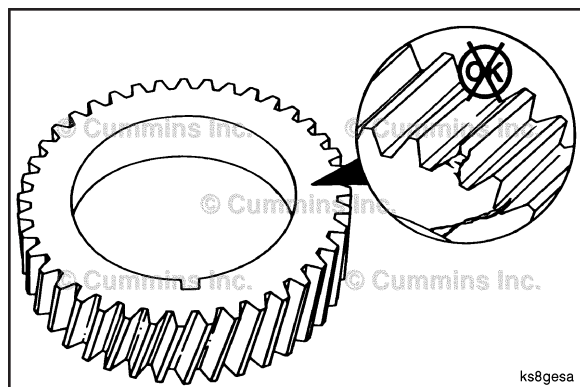

Visually inspect the gear and, for front gear train engines only, the keyway for nicks or burrs.

Use fine crocus cloth to remove nicks and burrs.

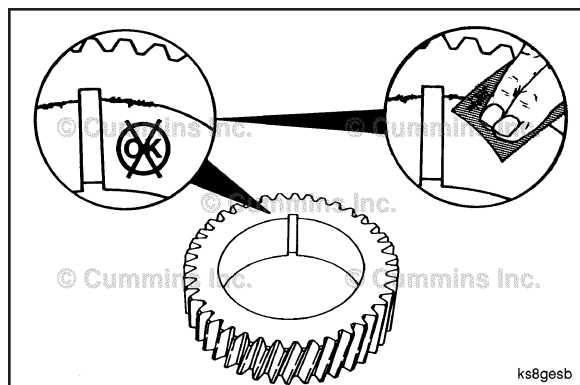

Visually inspect the crankshaft gear journal, gear alignment dowel pin and dowel pin hole for burrs or damage.

Use fine crocus cloth to remove burrs.

Replace the gear alignment dowel pin if damage is found.

NOTE: Rear gear train engines do **not** have any type of alignment pin for the front crankshaft gear.

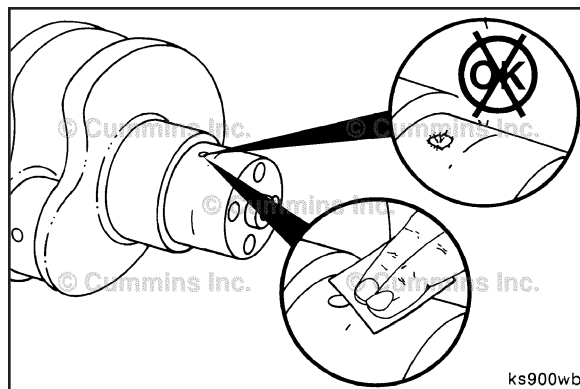

Measure the crankshaft gear bore inside diameter.



Crankshaft Gear Bore Inside Diameter

mm		in
70.51	MIN	2.776
70.55	MAX	2.779

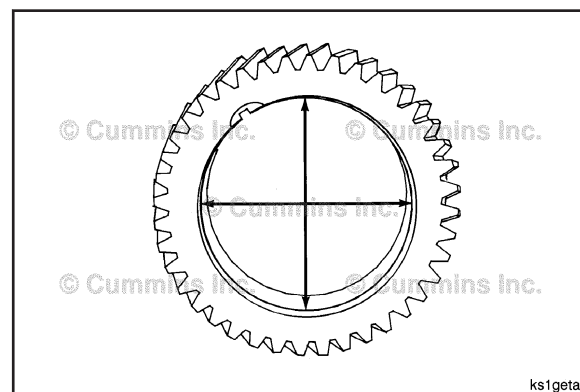

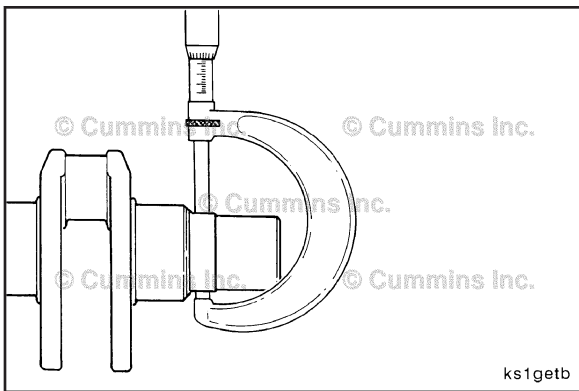

Measure the crankshaft gear journal outside diameter.

Crankshaft Gear Journal Outside Diameter

mm		in
70.59	MIN	2.779
70.61	MAX	2.780

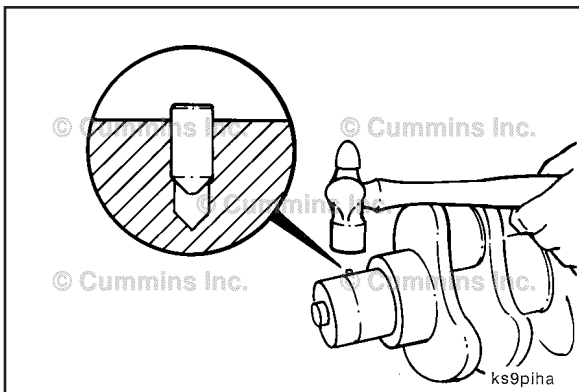

Install

Use a soft hammer to install the gear alignment dowel into the crankshaft.

The pin **must** be 1.02 mm [0.040 in] above the crankshaft surface.

NOTE: Rear gear train engines do **not** have any type of alignment pin for the front crankshaft gear.

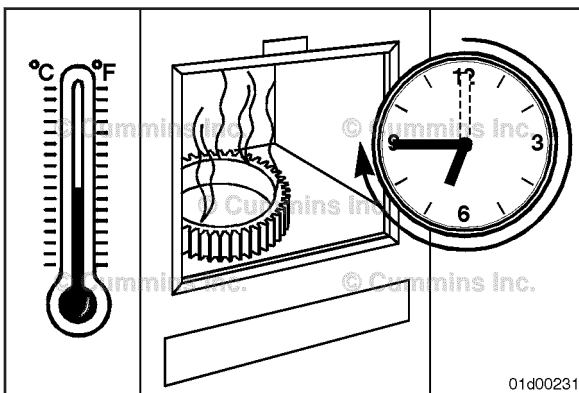

⚠ CAUTION ⚠

Do not exceed the specified heating time or temperature. The crankshaft teeth can be damaged.

Heat the gear in an oven for a minimum of 45 minutes, but not more than 2 hours at 177°C [350°F].

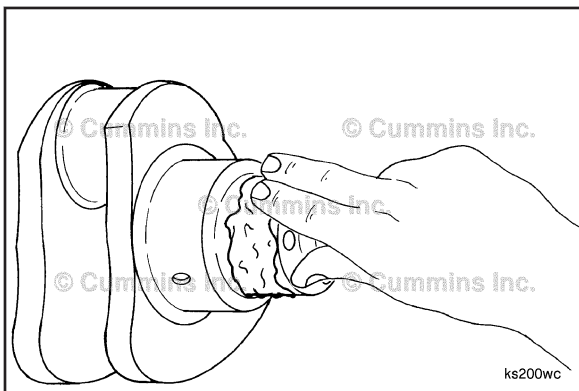

Use assembly lube, Part Number 3163087 or equivalent, to lubricate the outside diameter of the crankshaft gear journal.

▲WARNING▲

Wear protective gloves to reduce the possibility of personal injury when handling parts that have been heated.

▲CAUTION▲

For front gear train engines the timing mark (1) and part number (2) on the gear must be facing away from the crankshaft after the gear is installed. Engine damage can result if the gear is installed backwards.

▲CAUTION▲

Do not use water or oil to reduce the cooling time. The gear can crack. Allow the gear to air cool.

NOTE: Rear gear train engines do not have any type of keyway or timing mark on the front crankshaft gear. The gear can be installed in any orientation.

Remove the gear from the oven.

Align the keyway of the gear with the alignment dowel pin in the crankshaft and install the gear within 30 seconds.

For front gear train engines, align the keyway of the gear with the alignment dowel pin in the crankshaft. Install the crankshaft gear within 30 seconds of removing it from the oven.

If the gear cools and stops on the crankshaft before it is fully installed, use a driver to complete the installation.

Make sure the gear is seated against the crankshaft shoulder. Use a 0.02 mm [0.001 in] feeler gauge to check to see if the feeler gauge can be inserted between the crankshaft gear and the shoulder on the crankshaft. If the feeler gauge can be inserted, the crankshaft gear is **not** properly seated and **must** be removed and installed again.

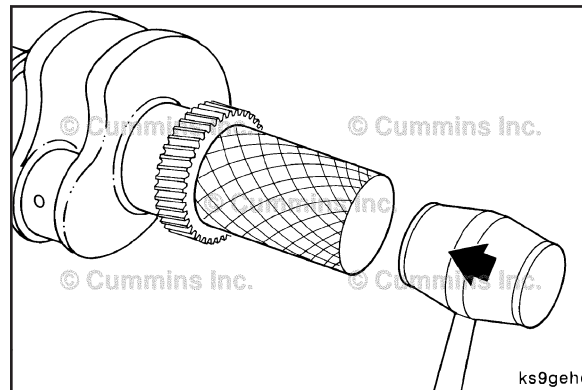
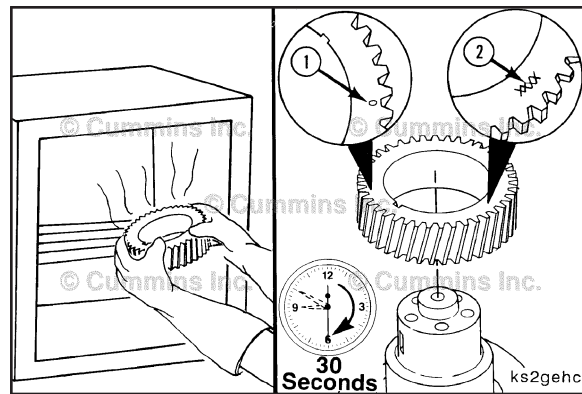

Crankshaft Gear, Rear (Crankshaft Removed) (001-020)



General Information

The crankshaft gear can **not** be replaced on rear gear train engines. If the gear is damaged, the crankshaft assembly **must** be replaced.

Refer to Procedure 001-016 in Section 1 for crankshaft assembly removal.

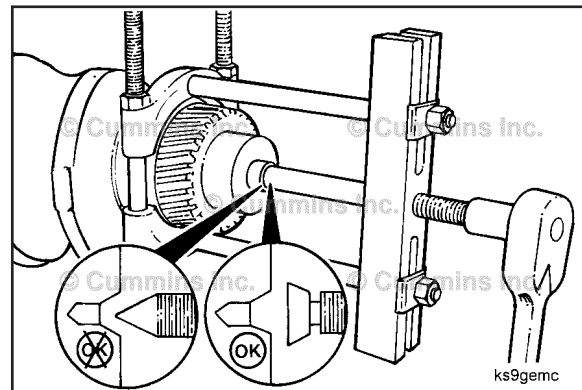

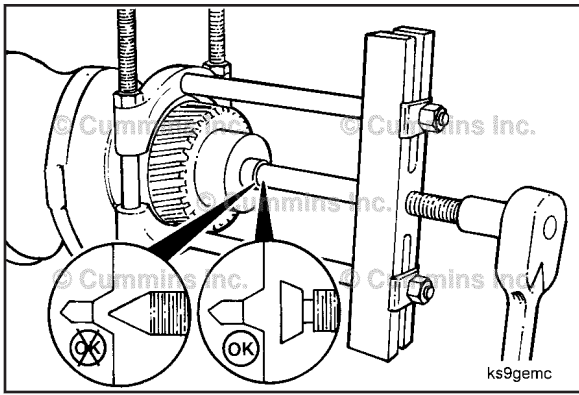

Crankshaft Gear, Rear (Crankshaft Removed) (001-021)

General Information

The crankshaft gear can **not** be replaced on rear gear train engines. If the gear is damaged, the crankshaft assembly **must** be replaced. Refer to Procedure 001-016 in Section 1

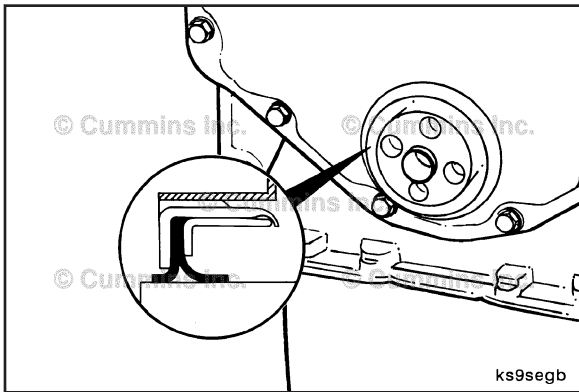

Crankshaft Seal, Front (001-023)

General Information

Lip Seal

Some engines use a lip style front crankshaft Seal (shown) in which the rotating portion of the sealing occurs at the contact surface between the lip of the seal and the crankshaft.

Always replace the front crankshaft seal with the same style seal as was previously installed.

Engines that commonly use a lip style front crankshaft seal include:

Automotive and Marine 5.9L engines.

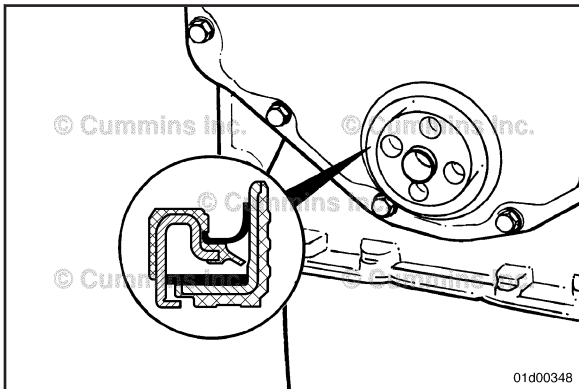

Unitized Seal

Some engines use a dual or non-lip style seal which utilize a built in wear sleeve and a concealed sealing lip. The inner and out diameter are press-fit onto the crankshaft and the front gear cover respectively, requiring service tool, Part Number 3164659, to remove and install. The sealing point is internal to the seal.

Always replace the front crankshaft seal with the same style seal as was previously installed.

Engines that commonly use a unitized front crankshaft seal include:

Automotive 3.9L and 5.9L engines

Industrial and Automotive 4.5L and 6.7L engines

Preparatory Steps

⚠ WARNING ⚠

Batteries can emit explosive gases. To reduce the possibility of personal injury, always ventilate the compartment before servicing the batteries. To reduce the possibility of arcing, remove the negative (-) battery cable first and attach the negative (-) battery cable last.

Disconnect the batteries.

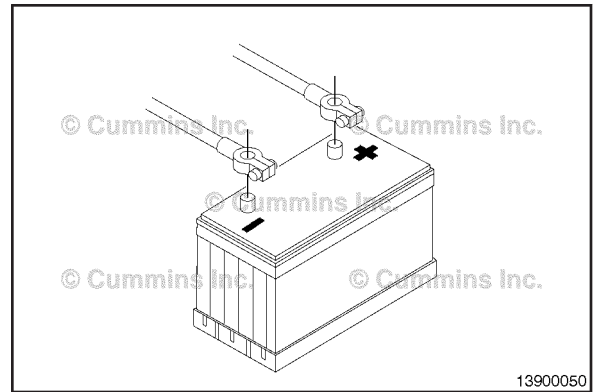

Remove the belt guards, if equipped. Refer to Procedure 008-001

Remove the sea water pump drive belt, if equipped. Refer to Procedure 008-126

Remove the engine water pump (cooling fan) drive belt. Refer to Procedure 008-002

Remove the fan hub. Refer to Procedure 008-039

Remove the camshaft position sensor. See Section 19 of the corresponding Electronic Troubleshooting and Repair manual, for the engine being serviced.

Remove the vibration damper/crankshaft speed indicator ring. If equipped with a viscous damper, Refer to Procedure 001-052, If equipped with a rubber damper, Refer to Procedure 001-051. If equipped with a crankshaft speed indicator ring only, Refer to Procedure 001-071

Remove the front gear cover. Refer to Procedure 001-031

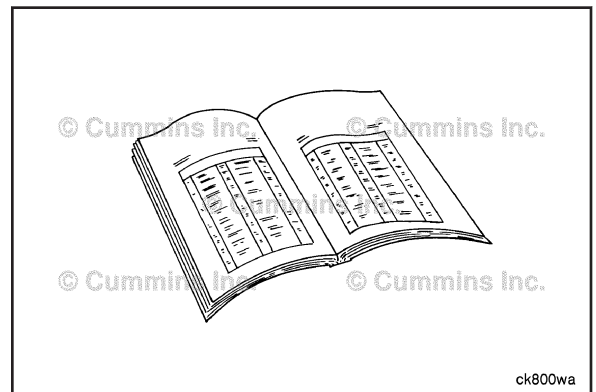

⚠ WARNING ⚠

Batteries can emit explosive gases. To reduce the possibility of personal injury, always ventilate the compartment before servicing the batteries. To reduce the possibility of arcing, remove the negative (-) battery cable first and attach the negative (-) battery cable last.

Disconnect the batteries.

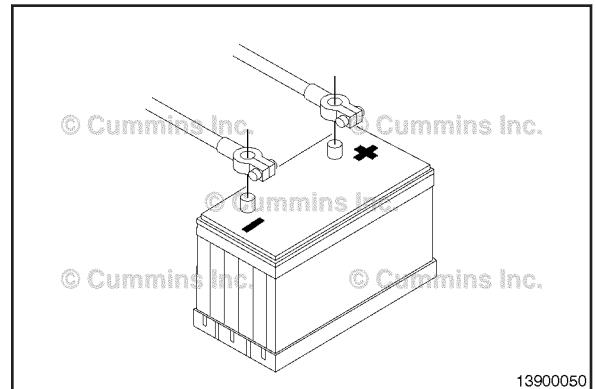

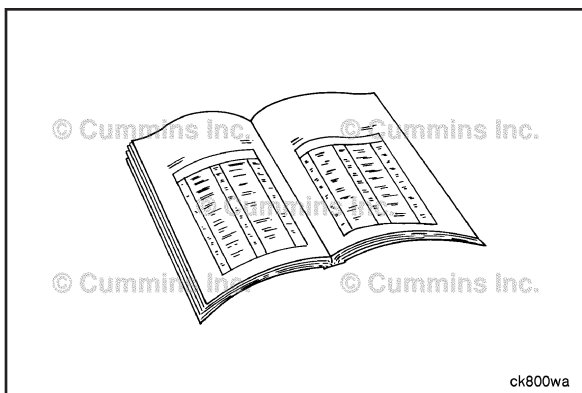

Remove the cooling fan drive belt. Refer to Procedure 008-002

Remove the vibration damper/crankshaft speed indicator ring. If equipped with a viscous damper, Refer to Procedure 001-052. If equipped with a rubber damper, Refer to Procedure 001-051. If equipped with a crankshaft speed indicator ring only, Refer to Procedure 001-071

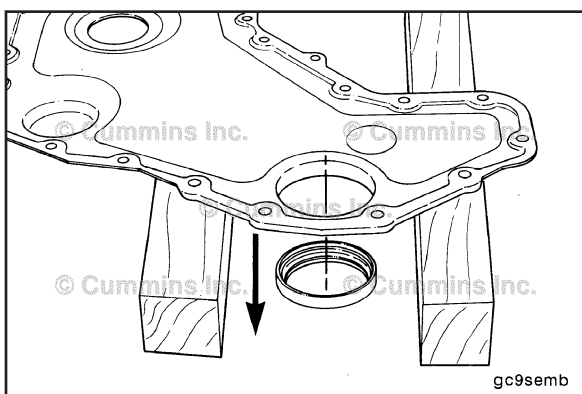

Remove

Support the front gear cover on a flat work surface with wooden blocks. Using a suitable punch and hammer, drive the old seal out of the front gear cover from the back side of the cover to the front side.

NOTE: Some engines may have an addition dust seal installed in front of the front crankshaft seal.

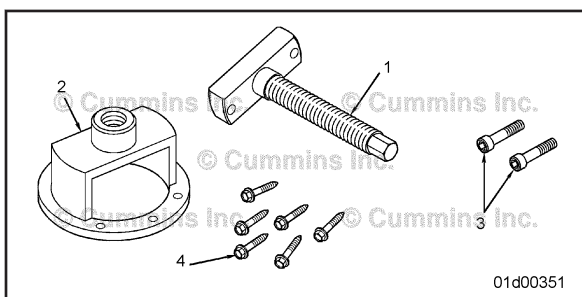

Use tool, Part Number 3164659, to remove the front crankshaft seal from the front gear cover.

Table 1. Front Crankshaft Seal Replacer Kit, Part Number 3164659			
Item Number	Part Number	Description	Quantity
1	3164667	Replace screw assembly	1
2	3164661	Crankshaft seal replacer	1
3	3164239	Socket head capscrew, M12 x 1.25 x 60 mm	2
4	3164217	Sheet metal screw, Number 10 x 25.4 mm [1 in] long	25 (6 shown)
Not shown	3164218	Drill. 3.57 mm [9/64 in]	1

NOTE: The front gear cover does **not** need to be removed to remove and install the crankshaft seal.

Mount the replacer screw assembly (1) onto the crankshaft nose.



Install the two M12 x 1.25 x 60-mm socket head capscrews (3).

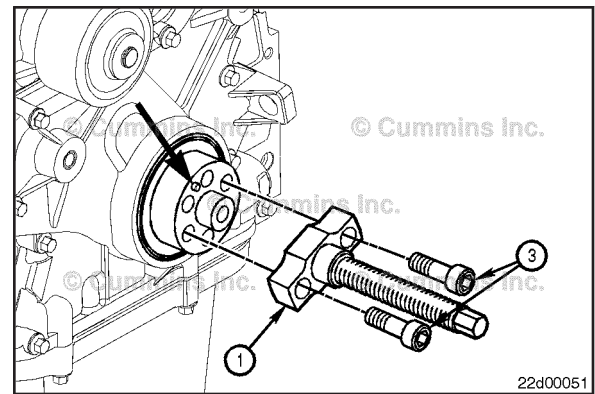

Lubricate the replacer screw with anti-seize or a suitable grease.



Hold the replacer screw and install the crankshaft seal replacer (2) onto the replacer screw assembly. Advance the crankshaft seal replacer toward the seal by rotating it **clockwise** until it is positioned against the front gear cover.

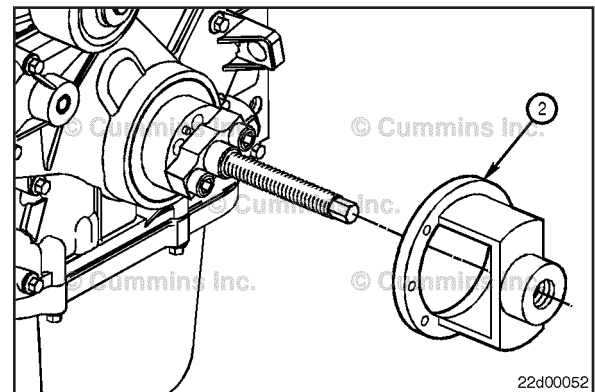

⚠ CAUTION ⚠

Drill the hole carefully and straight to reduce the possibility of damage to the front cover or the crankshaft.

Service Tip: Because of space restrictions, it may be necessary to use a compact right angle drill. Also, it may be necessary to shorten the drill bit used to drill the sheet metal screw holes.

NOTE: The flange of the crankshaft seal replacer is 8 mm [0.32 in] thick.

Mark the drill to a depth of 18 mm [0.71 in] with tape for drill depth control and apply grease to the drill to catch the chips. Stop frequently to remove the chips.

With the crankshaft seal replacer positioned against the front gear cover, drill one hole 10 mm [0.39 in] deep. Make sure the marking tape has **not** moved from the original position.

Install one sheet metal screw (4) into the seal to hold the crankshaft seal replacer in position.

Drill five additional holes 10 mm [0.39 in] deep and install the additional five sheet metal screws.

NOTE: Make sure all six sheet metal screws are threaded through both the inner and outer seal casings. The sheet metal screws need to be uniformly tightened in order to pull out the inner and outer casings of the seal together.

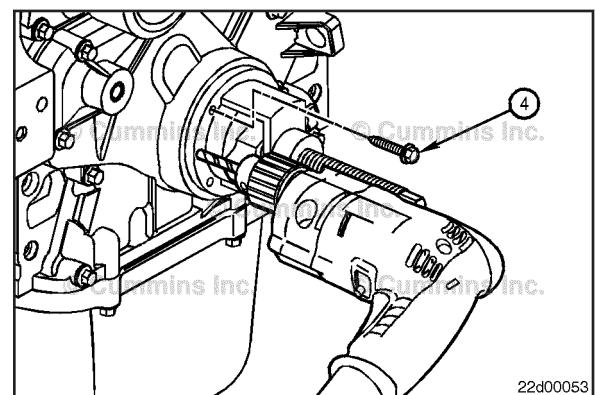

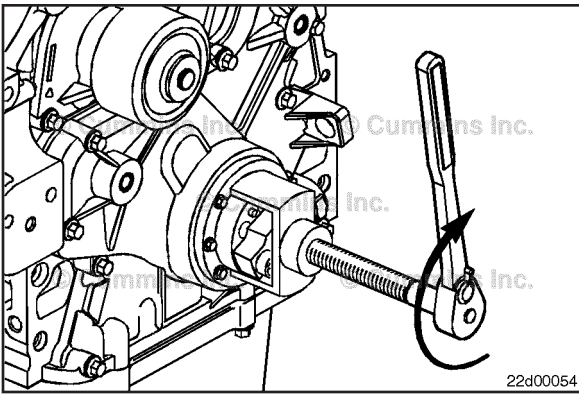

CAUTION

Do not use an impact wrench or air tools. Doing so can damage the tool.

Slowly rotate the replacer screw **clockwise** until the seal is removed. Do **not** exceed torque value.

Torque Value: 33 N•m [45 ft-lb]

NOTE: If the sheet metal screws pull out of the seal or **only** the inner casing pulls out, stop the removal operation. Rotate the replacer screw **counterclockwise** to force the inner casing back. Remove the sheet metal screws, slightly reorient the tool, drill new holes, and install the sheet metal screws in the new locations.

Complete the removal procedure, remove the tool, and discard the old seal.

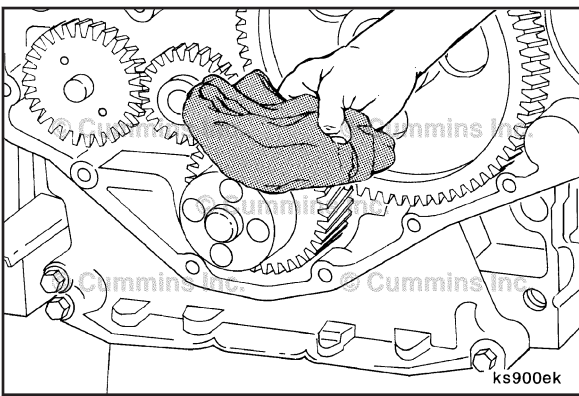

Clean and Inspect for Reuse

WARNING

When using solvents, acids, or alkaline materials for cleaning, follow the manufacturer's recommendations for use. Wear goggles and protective clothing to reduce the possibility of personal injury.

WARNING

Some solvents are flammable and toxic. Read the manufacturer's instructions before using.

WARNING

Wear appropriate eye and face protection when using compressed air. Flying debris and dirt can cause personal injury.

Using solvent, clean the oil and seal residue from the crankshaft surface.

Dry with compressed air.

⚠ WARNING ⚠

When using solvents, acids, or alkaline materials for cleaning, follow the manufacturer's recommendations for use. Wear goggles and protective clothing to reduce the possibility of personal injury.

⚠ WARNING ⚠

Some solvents are flammable and toxic. Read the manufacturer's instructions before using.

⚠ WARNING ⚠

Wear appropriate eye and face protection when using compressed air. Flying debris and dirt can cause personal injury.

For front gear train engines, use a gasket scraper or abrasive pad, Part Number 3823258 or equivalent, to remove all sealant on the front gear cover and front gear housing.

Clean the gasket sealing surfaces and the surface between the oil seal and front gear cover.

Use solvent to clean the front gear cover.

For rear gear train engines, clean the front gear cover seal bore of any seal residue. Inspect the front gear cover seal bore for nicks or burrs. Use an abrasive pad, Part Number 3823258 or equivalent, to remove any minor damage.

Dry with compressed air.

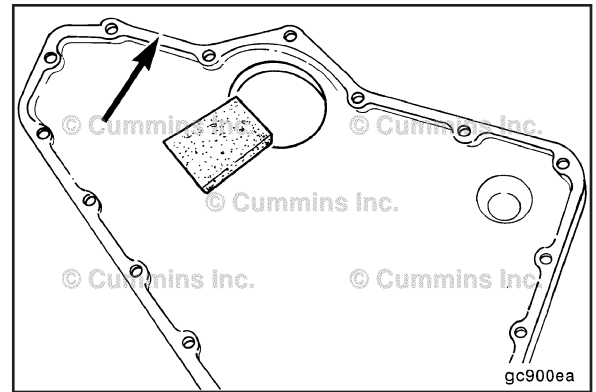

⚠ CAUTION ⚠

The seal lip and the sealing surface on the crankshaft must be free from all oil residue to prevent seal leaks.

NOTE: If the crankshaft has excessive wear, a service wear sleeve is available for engines that use a lip style front crankshaft seal.

Inspect the nose of the crankshaft for excessive wear.

For engines equipped with a non-lip style front crankshaft seal, use a fine crocus cloth to remove any nicks or burrs. No wear sleeve is available if the crankshaft nose sealing surface is damaged.

For engines equipped with a lip style front crankshaft seal, inspect the crankshaft seal contact area for a wear groove. If the groove is deeper than 0.25 mm [0.010 in], a wear sleeve and oversize seal **must** be used. Refer to Procedure 001-025

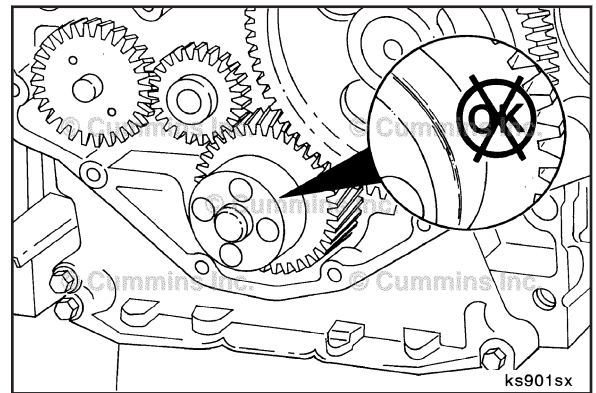

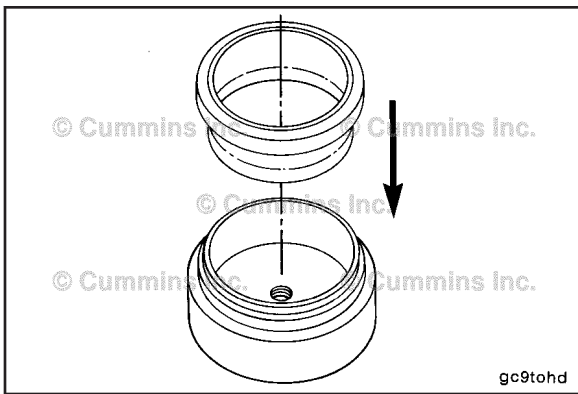

Install

Leave the plastic pilot installation tool in the front crankshaft seal.

Position the seal on the seal installation tool, Part Number 3824498, with the seal dust lip facing outward.

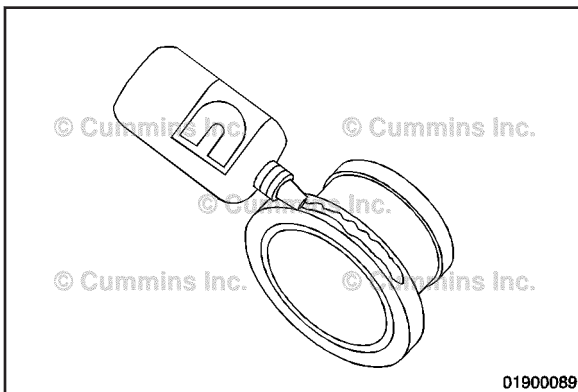

Apply a bead of sealant, Part Number 3824498, to the outside circumference of the seal.

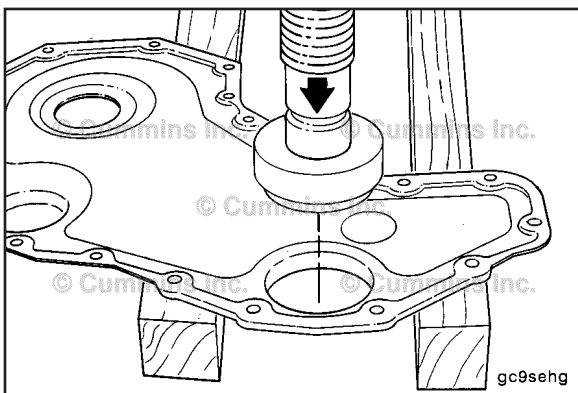

⚠CAUTION⚠

Properly support the front cover lubricating oil seal flange to prevent damage to the lubricating oil seal and front cover.

Press the lubricating oil seal into the front cover from the backside of the cover toward the frontside of the cover.

Press the lubricating oil seal until the oil seal installation tool, Part Number 3824498, bottoms against the front cover.

NOTE: Each front crankshaft seal kit comes with an installation tool. This tool can be used in place of front crankshaft seal installation tool, Part No. 3824498, if **not** available. Using a mallet, tap around the installation tool to drive the front crankshaft seal into the front gear cover until the installation tool bottoms against the front gear cover.

The seal lip and the sealing surface on the crankshaft **must** be free from all oil residue to prevent seal leaks.

Apply a thin bead of sealant, Part Number 3164070, to the sealing surface of the front cover.

NOTE: Do **not** remove the plastic seal pilot tool from the front crankshaft seal at this time. Use the plastic seal pilot tool to guide the seal on the crankshaft.

NOTE: Install the front cover within 10 minutes of applying the sealant, or the sealant will **not** seal correctly. Once installed, allow the sealant to dry for 30 minutes before running the engine.

Install the front gear cover on the engine, using the plastic seal pilot tool to guide the front crankshaft seal onto the crankshaft.

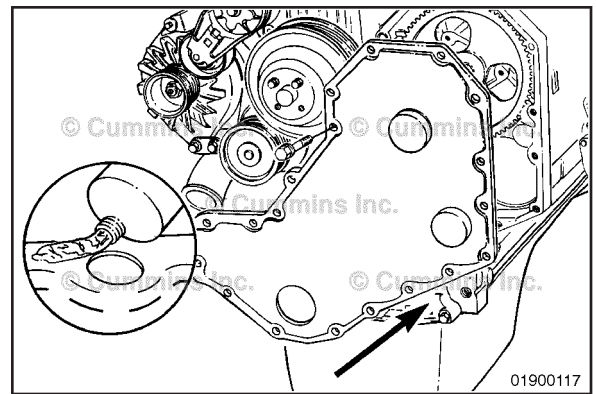

Install and tighten the front gear cover capscrews in the order indicated.

Torque Value: 24 N•m [18 ft-lb]

Remove the plastic pilot tool from the crankshaft.

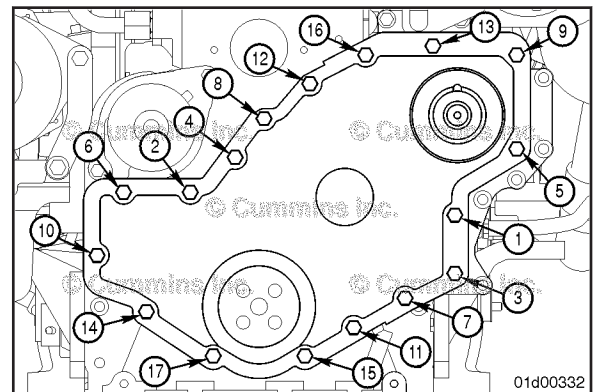

If previously equipped or if the engine operates in a dusty environment, install a dust seal.

A pilot tool is not necessary for the dust seal. Slide the dust seal over the nose of the crankshaft.

Use the installation tool that came with the new front crankshaft seal to install the dust seal into the front gear cover. Install the dust seal until it is even with the front gear cover.

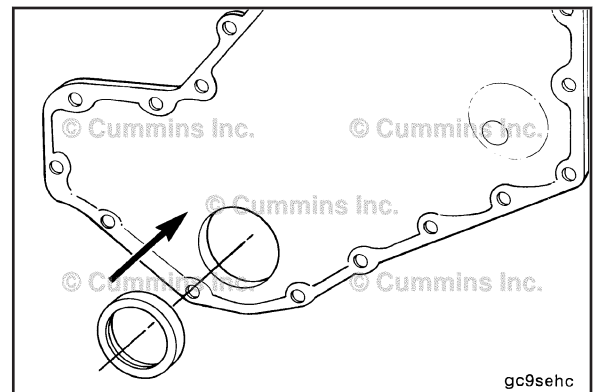

Use tool, Part Number 3164659, to install the oil seal into the front gear cover.

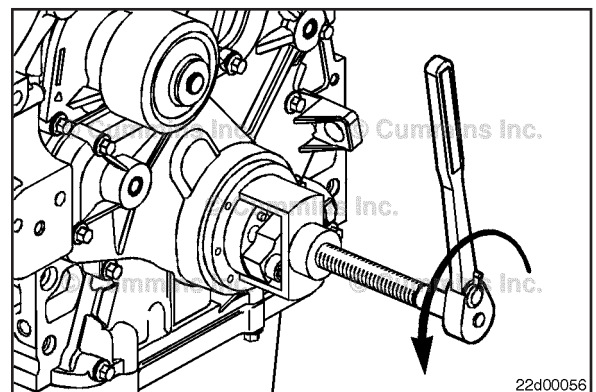

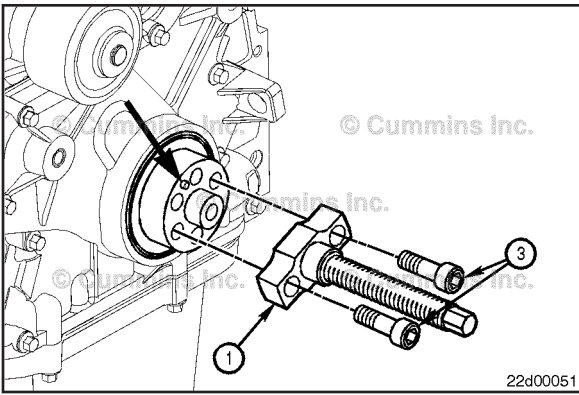

Mount the replacer screw assembly (1) onto the crankshaft nose.

Install the two M12 x 1.25 x 60 mm socket head capscrews (3).

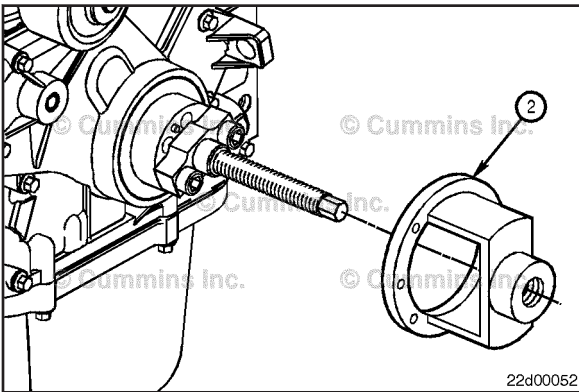

⚠ CAUTION ⚠

Do not use an impact wrench or air tools. Doing so can damage the tool.

Place the new front crankshaft seal over the crankshaft nose and slide it by hand toward the front gear cover as far as possible.

NOTE: Make sure the seal is positioned squarely with the crankshaft.

While holding the replacer screw, install the crankshaft seal replacer (2) onto the replacer screw assembly.

Advance the crankshaft seal replacer toward the seal by rotating it **clockwise** until it is positioned against the seal.

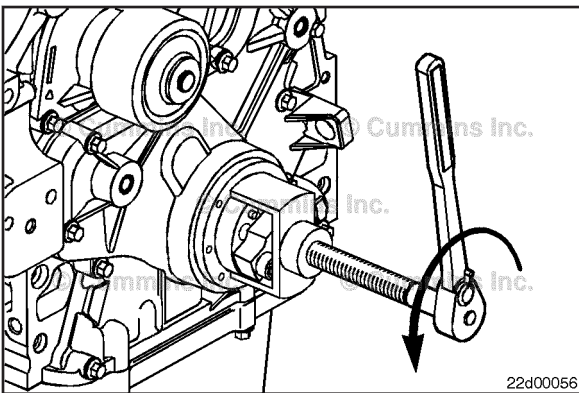

⚠ CAUTION ⚠

Do not overtighten the replacer screw assembly after the crankshaft seal replacer contacts the front cover. Doing so can damage the tool.



While holding the crankshaft seal replacer, rotate the replacer screw **counterclockwise** until the crankshaft seal replacer contacts the front gear cover.

Remove the service tools.

Finishing Steps

Install the front gear cover. Refer to Procedure 001-031

Install the vibration damper/crankshaft speed indicator ring. If equipped with a viscous damper, Refer to Procedure 001-052. If equipped with a rubber damper, Refer to Procedure 001-051. If equipped with a crankshaft speed indicator ring only, Refer to Procedure 001-071

Install the camshaft position sensor. See Section 19 of the corresponding Electronic Troubleshooting and Repair manual for the engine being serviced.

Install the fan hub if removed. Refer to Procedure 008-039

Install the engine water pump (cooling fan) drive belt. Refer to Procedure 008-002

For marine applications, install the sea water pump drive belt. Refer to Procedure 008-126

Install the belt guards, if equipped. Refer to Procedure 008-001

⚠ WARNING ⚠

Batteries can emit explosive gases. To reduce the possibility of personal injury, always ventilate the compartment before servicing the batteries. To reduce the possibility of arcing, remove the negative (-) battery cable first and attach the negative (-) battery cable last.

Connect the batteries.

Operate the engine and check for leaks.

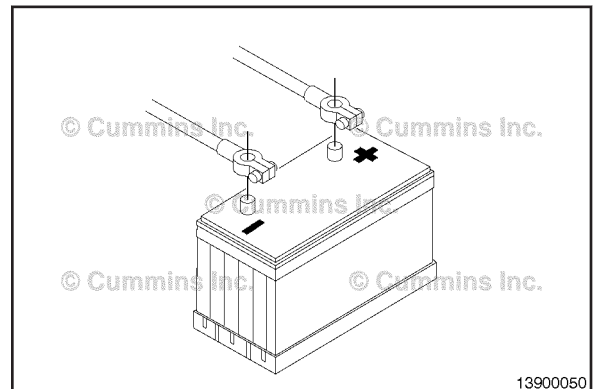
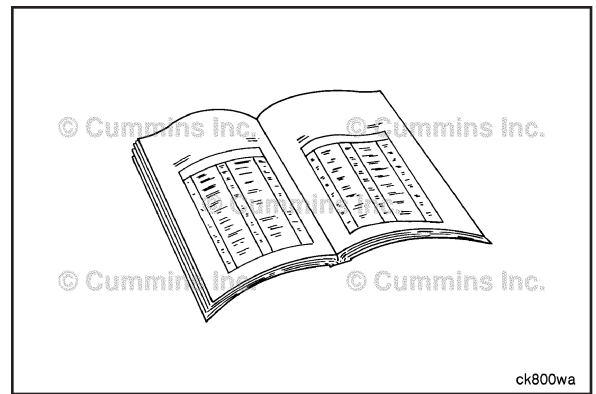

Install the vibration damper pulley/crankshaft speed indicator ring. If equipped with a viscous damper, Refer to Procedure 001-052. If equipped with a rubber damper, Refer to Procedure 001-051. If equipped with a crankshaft speed indicator ring only, Refer to Procedure Procedure 001-071

Install the cooling fan drive belt. Refer to Procedure 008-002

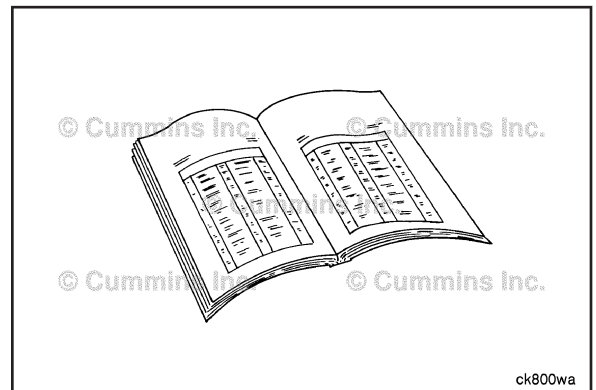

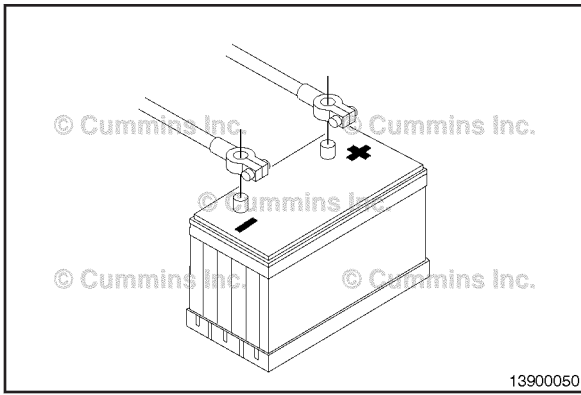

▲ WARNING ▲

Batteries can emit explosive gases. To reduce the possibility of personal injury, always ventilate the compartment before servicing the batteries. To reduce the possibility of arcing, remove the negative (-) battery cable first and attach the negative (-) battery cable last.

Connect the batteries.

Operate the engine and check for leaks.

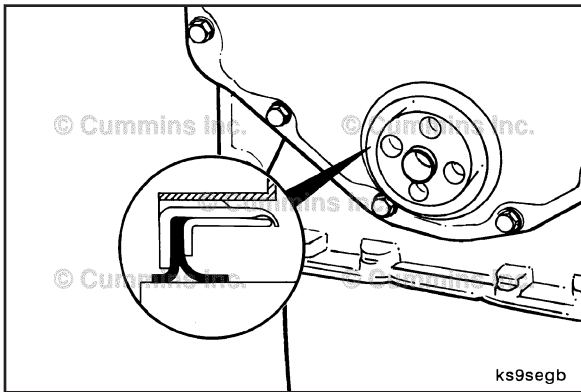

Crankshaft Seal, Rear (001-024)

General Information

Some engines use a lip style rear crankshaft seal (shown) in which the rotating portion of the sealing occurs at the contact surface between the lip of the rear crankshaft seal and the crankshaft.

Always replace the crankshaft seal with the same style crankshaft seal as was previously installed.

Engines that commonly use a lip style rear crankshaft seal include:

Front Gear Train Automotive and Marine 3.9L and 5.9L engines.

Industrial and Automotive 4.5L and 6.7L engines.

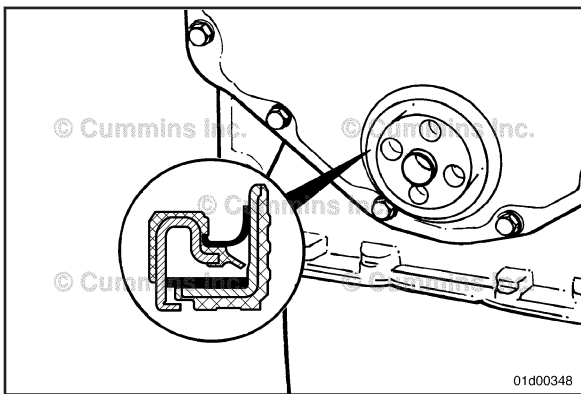

Some engines use a dual or non-lip style seal which utilize a built in wear sleeve and a concealed sealing lip. The inner and outer diameters are press-fit onto the crankshaft and the flywheel housing respectively, requiring service tool, Part Number 3164660, to remove and install. The sealing point is internal to the seal.

Always replace the crankshaft seal with the same style seal as was previously installed.

Engines that commonly use a unitized rear crankshaft seal include:

Rear Gear Train Automotive 3.9L and 5.9L engines.

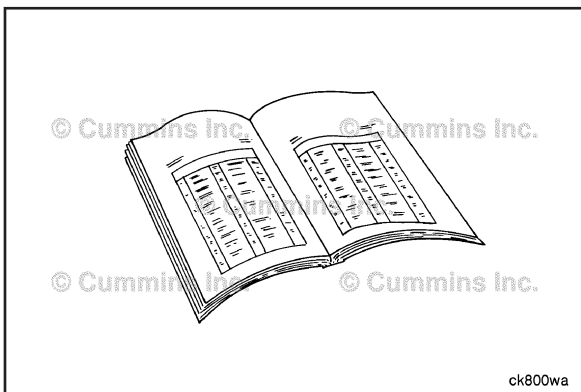

Preparatory Steps

Automotive and Industrial

▲ WARNING ▲

Batteries can emit explosive gases. To reduce the possibility of personal injury, always ventilate the compartment before servicing the batteries. To reduce the possibility of arcing, remove the negative (-) battery cable first and attach the negative (-) battery cable last.

- Disconnect the batteries. Refer to the OEM instructions.

- If equipped with a wet flywheel housing, drain the oil from the flywheel housing by removing the plug in the bottom of the flywheel housing.
- Note: Use a container that can hold at least 26 liters [27 US qt] of lubricating oil.
- Remove the transmission and all related components (if equipped). Refer to the OEM instructions.
- Remove the flywheel/flexplate. Refer to Procedure 016-005 in Section 16 or Refer to Procedure Procedure 016-004 in Section 16.

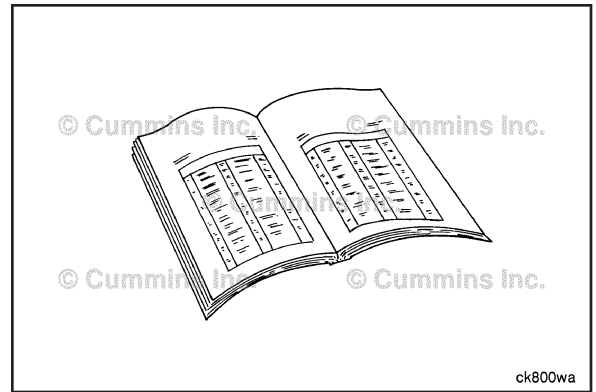

ck800wa

Marine Applications

⚠ WARNING ⚠

Batteries can emit explosive gases. To reduce the possibility of personal injury, always ventilate the compartment before servicing the batteries. To reduce the possibility of arcing, remove the negative (-) battery cable first and attach the negative (-) battery cable last.

- Disconnect the batteries. Refer to the OEM instructions.
- On some vessels, it can be necessary to drain the lubricating oil from the engine. Refer to Procedure 007-037 in Section 7.
- On some vessels, it can be necessary to lift the engine to replace the rear crankshaft seal.
- Close the sea water supply valve. Refer to the OEM service manual.
- Remove the air crossover from the turbocharger to the aftercooler. Refer to Procedure 010-019 in Section 10.
- Remove the marine gear cooler. Refer to Procedure 008-041 in Section 8.
- Remove the transmission. Refer to the OEM service manual.
- Remove the starting motor. Refer to Procedure 013-020 in Section 13.
- Remove the flywheel. Refer to Procedure 016-005 in Section 16.
- Remove and seal the exhaust system.

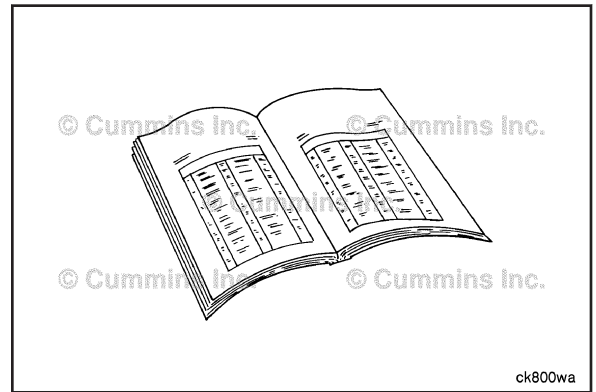

ck800wa

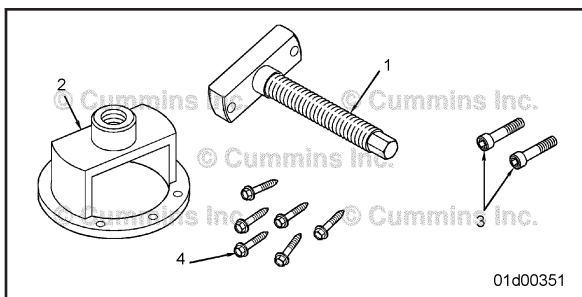

Remove

Rear Gear Train Engines with Unitized Seals

Use service tool, Part Number 3164660, to remove the seal.

Item Number	Part Number	Description	Quantity
1	3164666	Replace screw assembly	1
2	3164664	Crankshaft seal replacer	1
3	3164174	Socket head capcrew, M12 x 1.25 x 25 mm	2
4	3164217	Sheet metal screw, Number 10 x 25.4 mm [1 in] long	25 (7 shown)
Not shown	3164218	Drill. 3.57 mm [9/64 in]	1

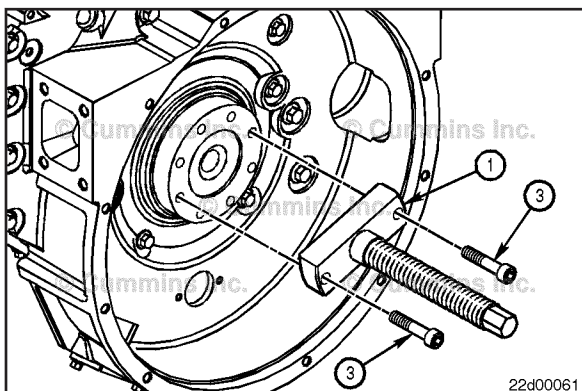

Mount the replacer screw assembly (1) onto the crankshaft nose.

Install the two M12 x 1.25 x 60-mm socket head cap screws (3).

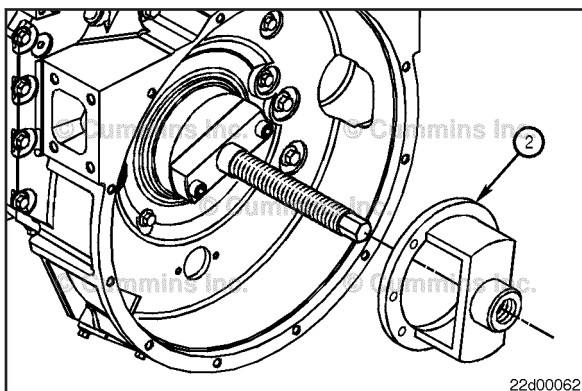

Lubricate the replacer screw with anti-seize compound or a suitable grease.



Hold the replacer screw and install the crankshaft seal replacer (2) onto the replacer screw assembly. Advance the crankshaft seal replacer toward the seal by rotating it **clockwise** until it is positioned against the flywheel housing.

⚠CAUTION⚠

Drill the hole carefully and straight to reduce the possibility of damage to the flywheel housing or the crankshaft.

Service Tip: Because of space restrictions, it may be necessary to use a compact right angle drill. Also, it may be necessary to shorten the drill bit used to drill the sheet metal screw holes.

NOTE: The flange of the crankshaft seal replacer is 12 mm [0.47 in] thick.

Mark the drill to a depth of 22 mm [0.71 in] with tape for drill depth control and apply grease to the drill to catch the chips. Stop frequently to remove the chips.

With the crankshaft seal replacer positioned against the flywheel housing, drill one hole 10 mm [0.39 in] deep. Make sure the marking tape has **not** moved from the original position.

Install one sheet metal screw (4) into the seal to hold the crankshaft seal replacer in position.

Drill five additional holes 10 mm [0.39 in] deep and install the additional five sheet metal screws.

NOTE: Make sure all six sheet metal screws are threaded through both the inner and outer seal casings. The sheet metal screws need to be uniformly tightened in order to pull out the inner and outer casings of the seal together.

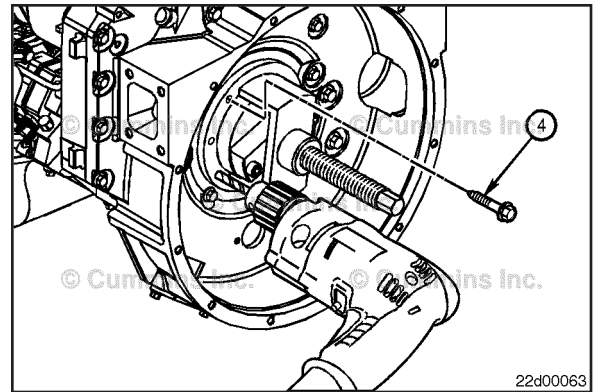

⚠CAUTION⚠

Do not use an impact wrench or air tools. Doing so can damage the tool.

Slowly rotate the replacer screw **clockwise** until the seal is removed. Do **not** exceed torque value.

Torque Value: 45 N•m [33 ft-lb]

NOTE: If the sheet metal screws pull out of the seal or **only** the inner casing pulls out, stop the removal operation. Rotate the replacer screw **counterclockwise** to force the inner casing back. Remove the sheet metal screws, slightly reorient the tool, drill new holes, and install the sheet metal screws in the new locations.

Complete the removal procedure, remove the tool, and discard the old seal.

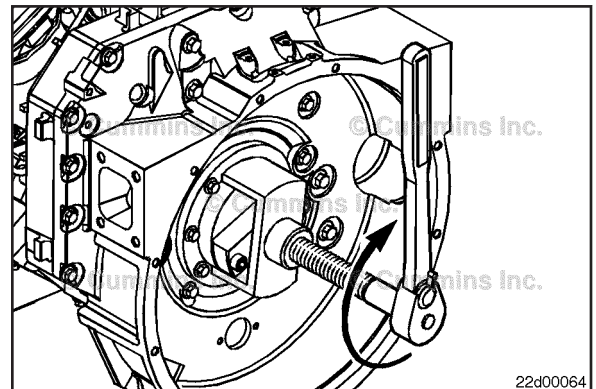

Lip Seal

NOTE: For engines equipped with a lip style rear crankshaft seal, the seal can also be removed using screws and a slide hammer. This procedure should **not** be followed on an engine with a unitized seal.

Drill two (2) holes 180-degrees apart into the seal carrier.

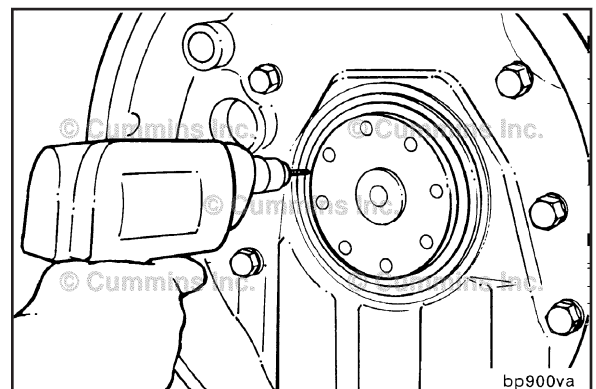

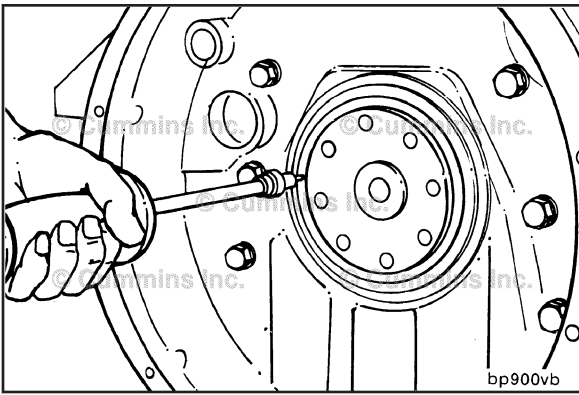

Install two coarse thread sheet metal screws in the holes just drilled. Use a slide hammer to remove the rear crankshaft seal.

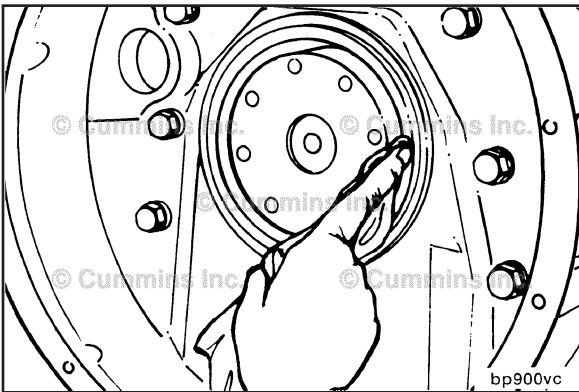

Clean and Inspect for Reuse

⚠ WARNING ⚠

When using solvents, acids, or alkaline materials for cleaning, follow the manufacturer's recommendations for use. Wear goggles and protective clothing to reduce the possibility of personal injury.

⚠ WARNING ⚠

Compressed air used for cleaning should not exceed 207 kPa [30 psi]. Use only with protective clothing, goggles/shield, and gloves to reduce the possibility of personal injury.

⚠ CAUTION ⚠

The seal lip and the sealing surface on the crankshaft must be free from all oil residue to prevent seal leaks.

Clean the rear crankshaft sealing surface and bore with solvent.

Dry the surface with compressed air.

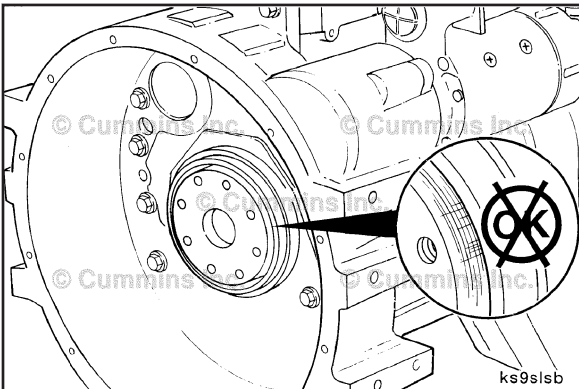

NOTE: If the crankshaft has excessive wear, a service wear sleeve is available for engines that use a lip style rear crankshaft seal.



Inspect the nose of the crankshaft for damage or excessive wear.

For engines with a non-lip style rear crankshaft seal, use a fine crocus cloth to remove any nicks or burrs. No wear sleeve is available if the crankshaft nose sealing surface is damaged.

For engines equipped with a lip style rear crankshaft seal, inspect the crankshaft seal contact area for a wear groove. If the groove is deeper than 0.25 mm [0.010 in], a wear sleeve and oversize seal **must** be used. Refer to Procedure 001-067 in Section 1.

Install

All Applications

⚠CAUTION⚠

Always replace the rear crankshaft seal with the same style seal as was previously installed to prevent oil leaks.

⚠CAUTION⚠

The seal lip/bore and the sealing surface on the crankshaft must be free from all oil residue to prevent seal leaks.

To aid in installation, apply a mild soap to the outside diameter of the seal case (A).

NOTE: On engines equipped with a lip style rear crankshaft seal, a seal pilot (B) is provided with the new seal. The seal **must** be left on the seal pilot while installing the seal onto the nose of the crankshaft. This will make sure the lips of the seal are **not** damaged during installation.

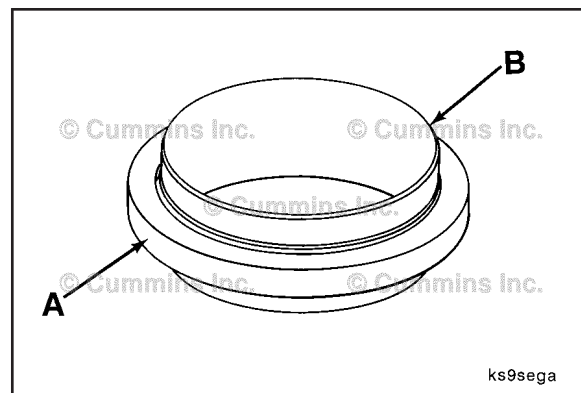

⚠CAUTION⚠

Always replace the rear crankshaft seal with the same style seal as was previously installed to prevent oil leaks.

Place the new rear crankshaft seal, with the seal pilot if required, over the crankshaft nose and slide it by hand toward the flywheel housing.

NOTE: Make certain the seal is positioned squarely with the crankshaft.

If used, remove the seal pilot.

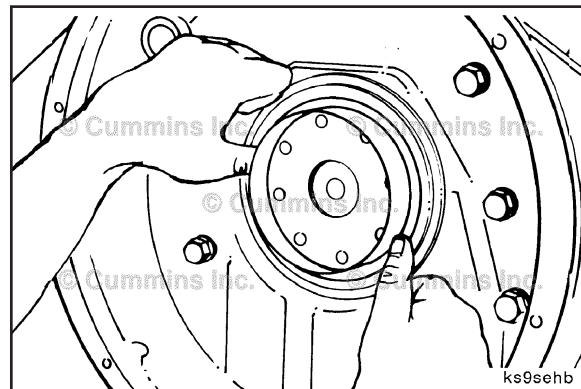

Unitized Seal

Use service tool, Part Number 3164660, to finish installing the rear crankshaft seal.

With the rear crankshaft seal installed onto the crankshaft flange as described earlier in this procedure, mount the replacer screw assembly (1) onto the rear of the crankshaft.

Install the two M12 x 1.25 x 60-mm socket head capscrews (3).

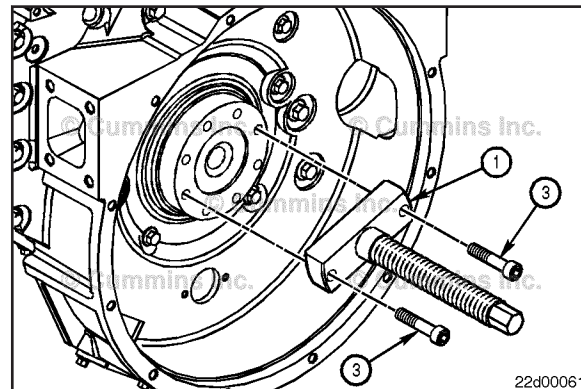

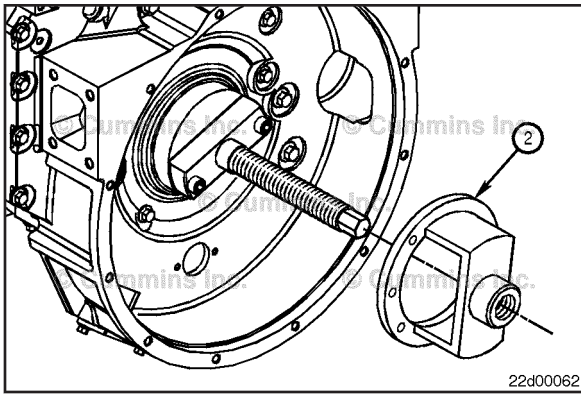

⚠ CAUTION ⚠

Do not use an impact wrench or air tools. Doing so can damage the tool.

While holding the replacer screw, install the crankshaft seal replacer (2) onto the replacer screw assembly.

Advance the crankshaft seal replacer toward the seal by rotating it **clockwise** until it is positioned against the seal.

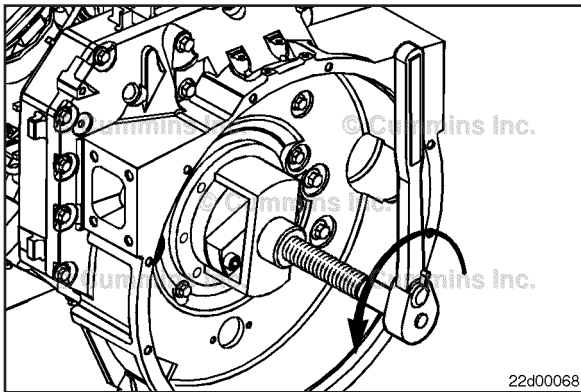

⚠ CAUTION ⚠

Do not overtighten the replacer screw assembly after the crankshaft seal replacer contacts the flywheel housing. Doing so can damage the tool.

While holding the crankshaft seal replacer, rotate the replacer screw **counterclockwise** until the crankshaft seal replacer is positioned against the flywheel housing.

Remove the service tools.

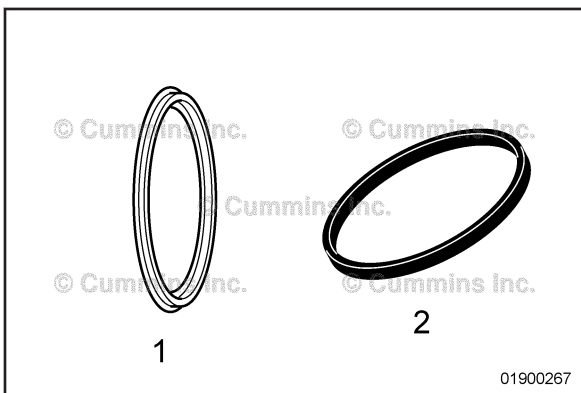

Lip Seal

Each new lip style crankshaft seal comes with a disposable seal.



- The seal driver (1) for front gear train engines, which is typically a metal ring, will install the crankshaft seal to the proper depth in the rear seal carrier bore.
- The seal driver (2) for rear gear train engines, which is typically a plastic ring, will install the crankshaft seal to the proper depth in the flywheel housing bore.

NOTE: For rear gear train engines, rear crankshaft seals for the wet flywheel housing applications do **not** come with a disposable seal driver. Service tool, Part Number 3824078, **must** be used to install the rear crankshaft seal for the wet flywheel housing. This is the same service tool used for installing the rear crankshaft seal and wear sleeve assembly. Refer to Procedure 001-067. For front gear train engines, this service tool can be used in place of the disposable seal driver that comes with the crankshaft seal.

For rear gear train engines, the disposable plastic driver that comes with the new rear crankshaft seal is designed to be used with two types of seals.

- A double outer dust lip rear crankshaft seal - for this type of seal, the side of the disposable driver (1) with the large chamfer on the inner diameter **must** be used to contact the seal.
- A single outer dust lip rear crankshaft seal - for this type of seal, the side of the disposable driver (2) with the small chamfer on the inner diameter **must** be used to contact the rear crankshaft seal.

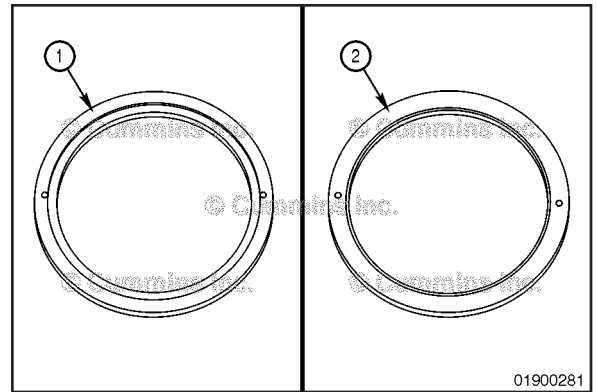

NOTE: It can be necessary to lightly tap the rear crankshaft seal with a plastic hammer, without the disposable seal driver, to help start the rear crankshaft seal in the flywheel housing bore.

With the rear crankshaft seal installed onto the crankshaft flange as described earlier in this procedure. Use the appropriate disposable seal driver that comes with each new rear crankshaft seal to install the crankshaft seal to the correct depth in the housing.

Use a plastic hammer to drive the crankshaft seal into the housing until the alignment tool stops against the housing. Hit the tool at 12, 3, 6 and 9 o'clock positions to drive the crankshaft seal evenly and to prevent bending the seal carrier.

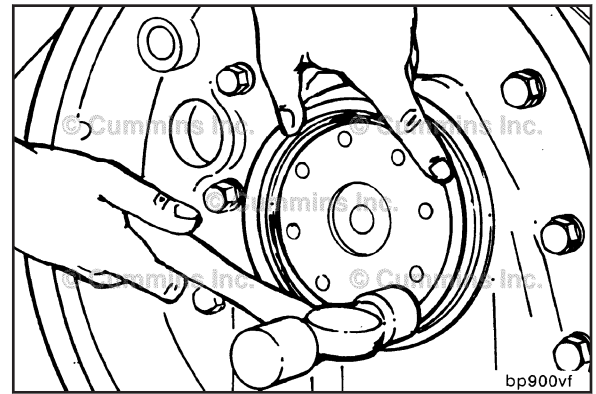

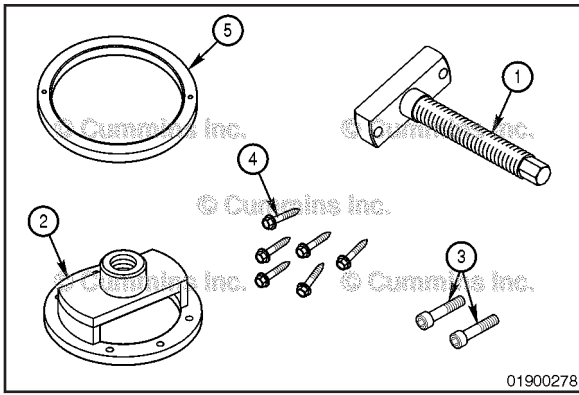

Optional Method

For rear gear train engines, the disposable plastic driver that comes with the new rear crankshaft seal has been designed with two holes in the outer ring. These holes are provided so that the driver can be used in conjunction with the Rear Crankshaft Seal Replacer Kit, Part Number 3164660.

Item Number	Part Number	Description	Quantity
1	3164666	Replace screw assembly	1
2	3164664	Crankshaft seal replacer	1
3	3164174	Socket head cap screw, M12 x 1.25 x 25 mm	2
4	3164217	Sheet metal screw, Number 10 x 25.4 mm [1 in] long	25 (7 shown)
Not shown	3164218	Drill, 3.57 mm [9/64 in]	1
5	—	Disposable plastic driver (purchased with rear crankshaft seal kit)	1

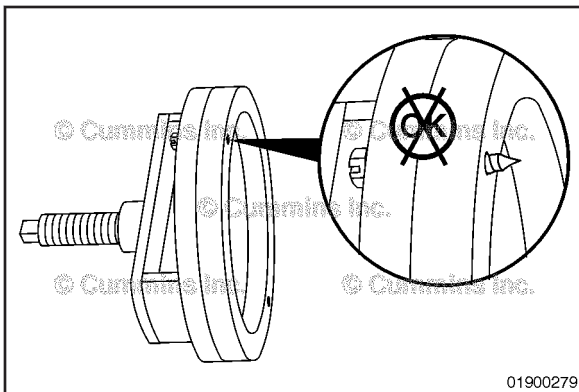

⚠ CAUTION ⚠

Do not use the sheet metal screws that come with the Rear Crankshaft Seal Replacer Kit, service tool part number 3164660. The sheet metal screws are too long. When selecting the correct sheet metal screw, make sure the tip of the sheet metal screw does not protrude past the face of the driver. Damage to the crankshaft seal will result.

With the correct side of the disposable driver facing outwards for the type of seal that will be installed, center the disposable driver on the crankshaft seal replacer.

Attach the disposable driver to the crankshaft seal replacer using a number 2 sheet metal screw (number 10 by 19 mm [.75 in] long).

With the rear crankshaft seal installed onto the crankshaft flange as described earlier in this procedure, mount the replacer screw assembly (1) onto the rear of the crankshaft.

Install the two M12 x 1.25 x 60-mm socket head capscrews (3).

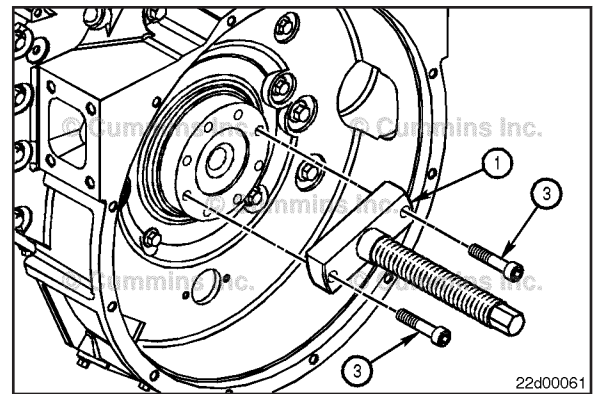

⚠ CAUTION ⚠

Do not use an impact wrench or air tools. Doing so can damage the tool.

Lubricate the replacer screw with anti-seize compound or a suitable grease.

Hold the replacer screw and install the crankshaft seal replacer (2) onto the replacer screw assembly. Advance the crankshaft seal replacer toward the seal by rotating it **clockwise** until the attached disposable driver is positioned against the rear crankshaft seal.

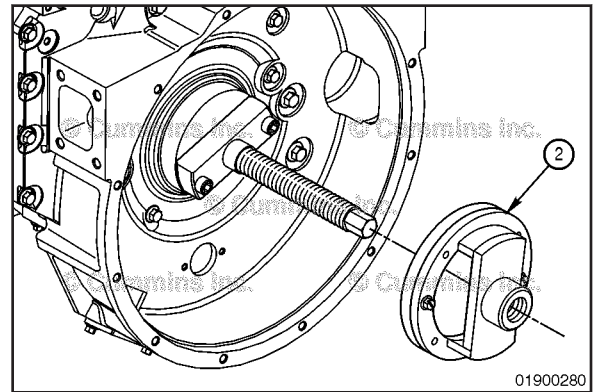

⚠ CAUTION ⚠

Do not overtighten the replacer screw assembly after the crankshaft seal replacer contacts the flywheel housing. Doing so can damage the tool.

While holding the crankshaft seal replacer, rotate the replacer screw counterclockwise until the disposable driver attached to the crankshaft seal replacer makes contact with the flywheel housing.

Remove the service tools.

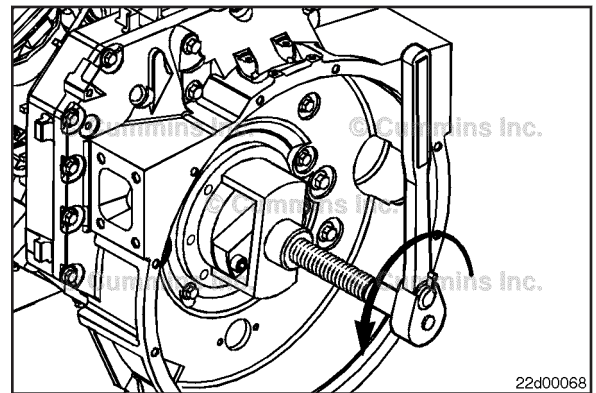

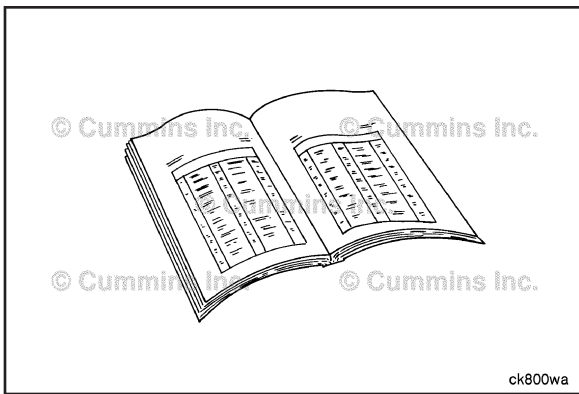

Finishing Steps

Automotive and Industrial



▲ WARNING ▲

Batteries can emit explosive gases. To reduce the possibility of personal injury, always ventilate the compartment before servicing the batteries. To reduce the possibility of arcing, remove the negative (-) battery cable first and attach the negative (-) battery cable last.



- Install the flywheel/flexplate. Refer to Procedure 016-005 in Section 16 or Refer to Procedure Procedure 016-004 in Section 16.
- Install the transmission and all related components (if equipped). Refer to the OEM instructions.
- Connect the batteries. Refer to the OEM instructions.
- Operate the engine and check for leaks.

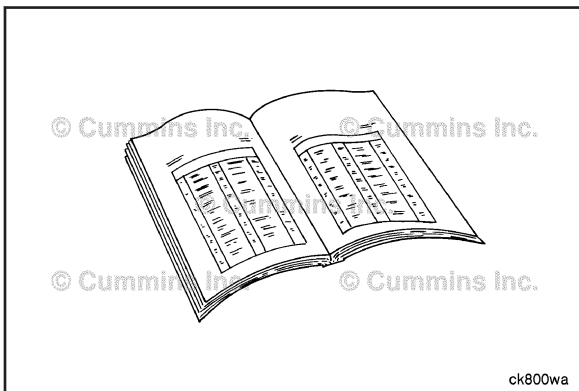

Marine Applications



▲ WARNING ▲

Batteries can emit explosive gases. To reduce the possibility of personal injury, always ventilate the compartment before servicing the batteries. To reduce the possibility of arcing, remove the negative (-) battery cable first and attach the negative (-) battery cable last.



- Install the flywheel. Refer to Procedure 016-005 in Section 16.
- Install the starting motor. Refer to Procedure 013-020 in Section 13.
- Install the transmission. Refer to the OEM service manual.
- Install the marine gear cooler. Refer to Procedure 008-041 in Section 8.
- Install the air crossover from the turbocharger to the aftercooler. Refer to Procedure 010-019 in Section 10.
- Connect the batteries. Refer to the OEM instructions.
- Lower the engine, if the engine was raised to replace the seal. Refer to Procedure 000-002 in Section 0.
- Install the exhaust system.
- Open the sea water valve. Refer to the OEM service manual.
- Operate the engine and check for leaks.

Crankshaft Wear Sleeve, Front (001-025)

General Information

Lip Seal

Some engines use a lip style front crankshaft seal (shown) in which the rotating portion of the sealing occurs at the contact surface between the lip of the seal and the crankshaft.

Engines that commonly use a lip style front crankshaft seal include:

Automotive and Marine 5.9L engines.

Unitized Seal

Other engines use a dual or non-lip style seal which utilize a built in wear sleeve and a concealed sealing lip. The inner and out diameter are press-fit onto the crankshaft and the front gear cover respectively, requiring service tool, Part Number 3164659, to remove and install. The sealing point is internal to the seal.

Engines that commonly use a unitized front crankshaft seal include:

Automotive 3.9L and 5.9L engines.

Industrial and Automotive 4.5L and 6.7L engines.

Only engines with a lip style front crankshaft seal can use a wear sleeve.

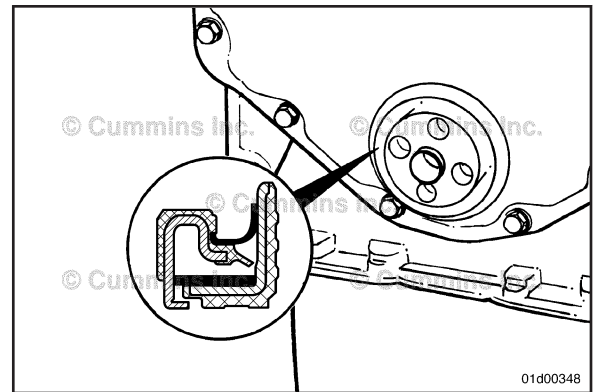
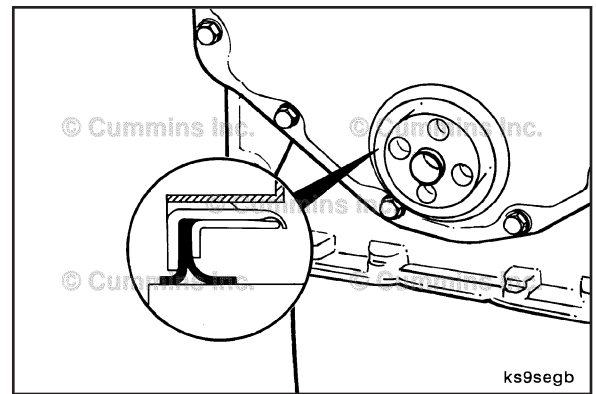

Preparatory Steps

Front Gear Train



Batteries can emit explosive gases. To reduce the possibility of personal injury, always ventilate the compartment before servicing the batteries. To reduce the possibility of arcing, remove the negative (-) battery cable first and attach the negative (-) battery cable last.

Disconnect the batteries.

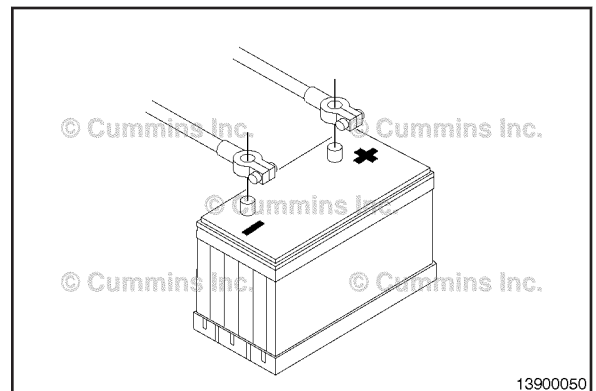

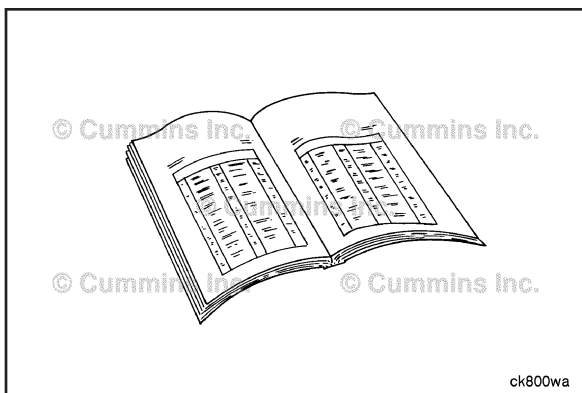

Remove the belt guards, if equipped. Refer to Procedure 008-001



For marine applications, remove the sea water pump drive belt, if equipped. Refer to Procedure 008-126

Remove the engine water pump (cooling fan) drive belt. Refer to Procedure 008-002

Remove the fan hub, if required. Refer to Procedure 008-039

Remove the camshaft position sensor. Refer to Procedure 019-363 in the corresponding Troubleshooting and Repair Manual.

Remove the vibration damper/crankshaft speed indicator ring. If equipped with a viscous damper, Refer to Procedure 001-052. If equipped with a rubber damper, Refer to Procedure 001-051. If equipped with a crankshaft speed indicator ring only, Refer to Procedure 001-071

Remove the front gear cover. Refer to Procedure 001-031

Remove the front crankshaft seal. Refer to Procedure Procedure 001-023

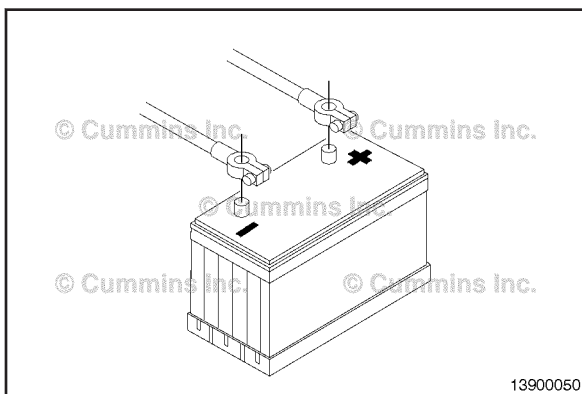

Rear Gear Train

▲ WARNING ▲

Batteries can emit explosive gases. To reduce the possibility of personal injury, always ventilate the compartment before servicing the batteries. To reduce the possibility of arcing, remove the negative (-) battery cable first and attach the negative (-) battery cable last.

Disconnect the batteries.

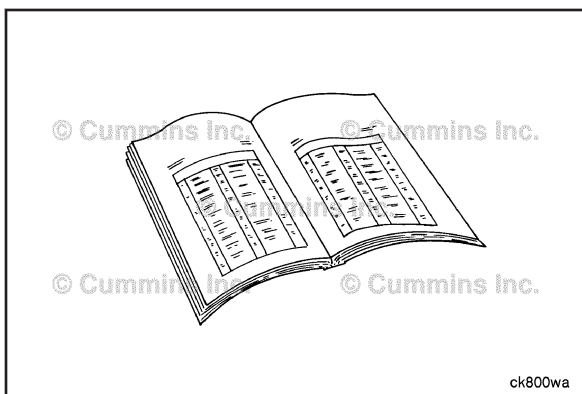

Remove the engine water pump (cooling fan) drive belt. Refer to Procedure 008-002



Remove the vibration damper/crankshaft speed indicator ring. If equipped with a viscous damper, Refer to Procedure 001-052. If equipped with a rubber damper, Refer to Procedure 001-051. If equipped with a crankshaft speed indicator ring only, Refer to Procedure 001-071

Remove the front crankshaft seal. Refer to Procedure Procedure 001-023

Remove

⚠ CAUTION ⚠

Do not nick or gouge the crankshaft with the chisel. If the crankshaft is damaged, it must be replaced.

NOTE: For rear gear train engines, if a wear sleeve has previously been installed, the front gear cover **must** be removed to remove the wear sleeve. Refer to Procedure Procedure 001-031

If a wear sleeve has previously been installed, use a dull chisel that is **only** as wide as the wear sleeve.

Make one or two soft blows with a hammer to make chisel marks across the wear sleeve. This will expand the wear sleeve allowing the sleeve to be removed.

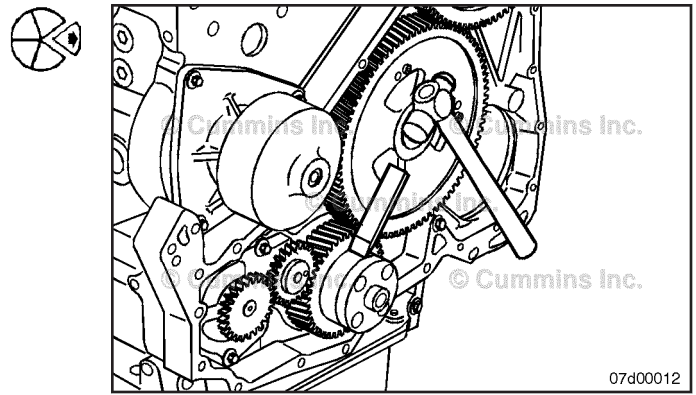

Clean and Inspect for Reuse

⚠ WARNING ⚠

When using solvents, acids, or alkaline materials for cleaning, follow the manufacturer's recommendations for use. Wear goggles and protective clothing to reduce the possibility of personal injury.

⚠ WARNING ⚠

Wear appropriate eye and face protection when using compressed air. Flying debris and dirt can cause personal injury.

Using solvent, clean the oil and seal residue from the crankshaft surface.

Dry with compressed air.

Use a crocus cloth to remove any rust or other deposits from the crankshaft flange.

Use a clean cloth and solvent to clean the crankshaft flange.

Inspect the crankshaft flange for nicks or burrs. Use an abrasive pad, Part Number 3823258 or equivalent, to remove any minor damage.

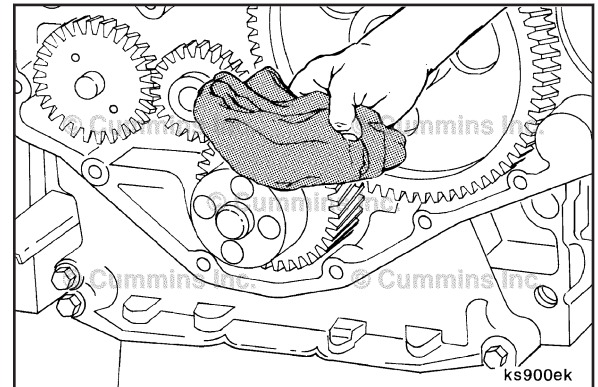

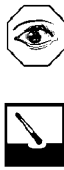
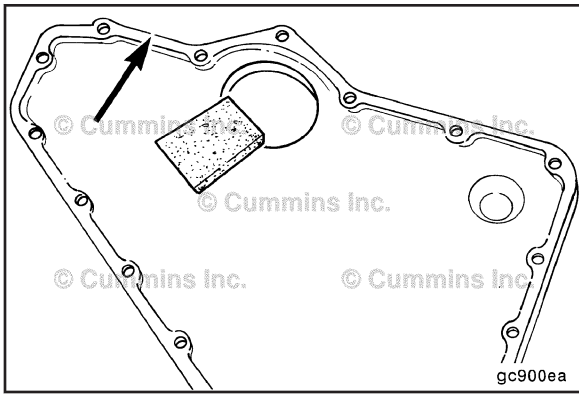

⚠ WARNING ⚠
When using solvents, acids, or alkaline materials for cleaning, follow the manufacturer's recommendations for use. Wear goggles and protective clothing to reduce the possibility of personal injury.

⚠ WARNING ⚠
Wear appropriate eye and face protection when using compressed air. Flying debris and dirt can cause personal injury.

For front gear train engines, use a gasket scraper or abrasive pad, Part Number 3823258 or equivalent, to remove all sealant on the front gear cover and front gear housing.

Clean the gasket sealing surfaces and the surface between the oil seal and front gear cover.

Use solvent to clean the front gear cover.

For rear gear train engines, clean the front gear cover seal bore of any seal residue.

Inspect the front gear cover seal bore for nicks or burrs. Use an abrasive pad, Part Number 3823258 or equivalent, to remove any minor damage.

Dry with compressed air.

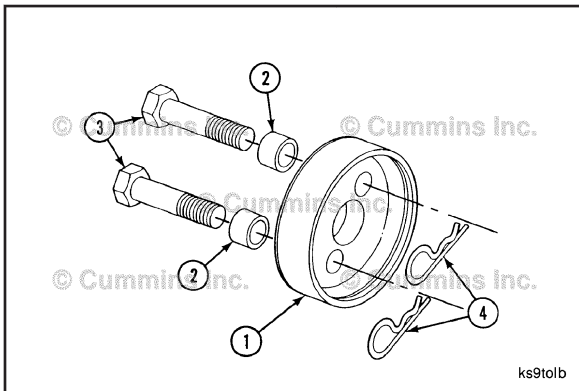

Install

Use the Crankshaft Front Wear Sleeve Installation Tool, Part No. 3824500, to install the wear sleeve.

The driver will be used to install the wear sleeve to the correct position on the crankshaft. The kit consists of the following:

Reference Number	Description	Quantity
1	Driver	1
2	Spacer	2
3	Capscrew M14 x 1.5 x 60 mm	2
4	Hairpin Cotter	2

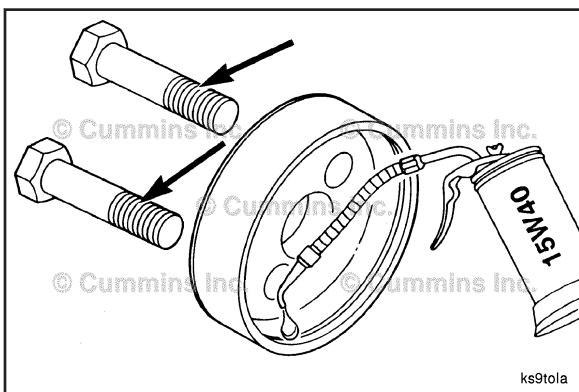

Apply a thin coat of clean 15W-40 lubricating oil to the inside diameter and capscrew threads.

Apply a thin coat of clean 15W-40 lubricating oil to the crankshaft flange.

Position the chamfered end of the wear sleeve onto the end of the crankshaft.

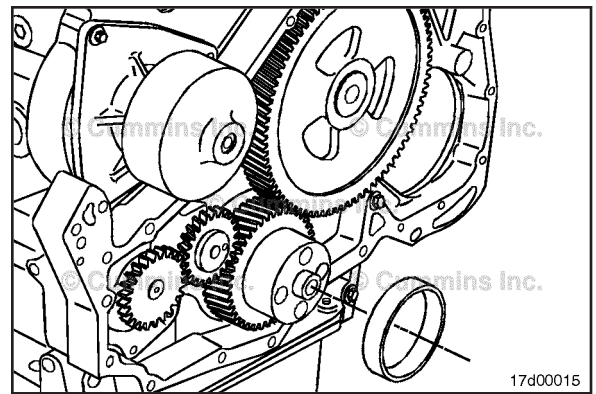

17d00015

Position the counterbore end of the driver onto the wear sleeve.

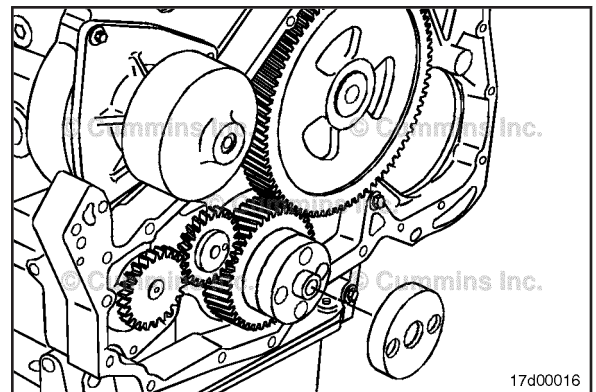

17d00016

Install two capscrews (without spacers) through the driver and into the crankshaft capscrew holes.

Align the wear sleeve and driver perpendicular to the crankshaft.

Tighten the capscrews "finger-tight".

- 1 Driver
- 2 Wear Sleeve
- 3 Crankshaft
- 4 Capscrew

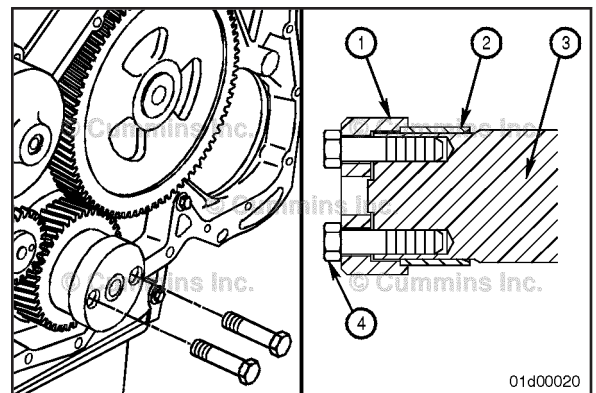

01d00020

⚠ CAUTION ⚠

To prevent damage to the wear sleeve, do not exceed one-half revolution of each capscrew.

Alternately tighten the capscrews one-half turn until the sleeve is installed to a depth of approximately 16 mm [0.625 in].

Torque Value: 20 N•m [15 ft-lb]

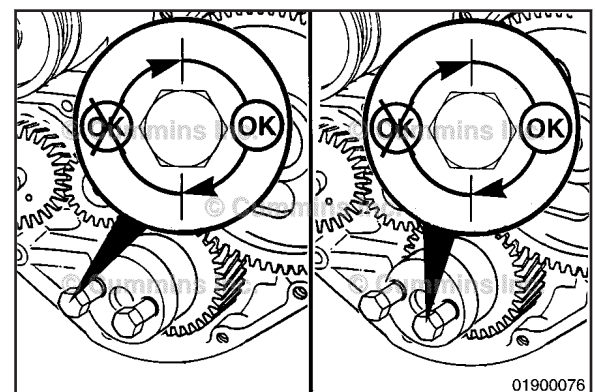

01900076

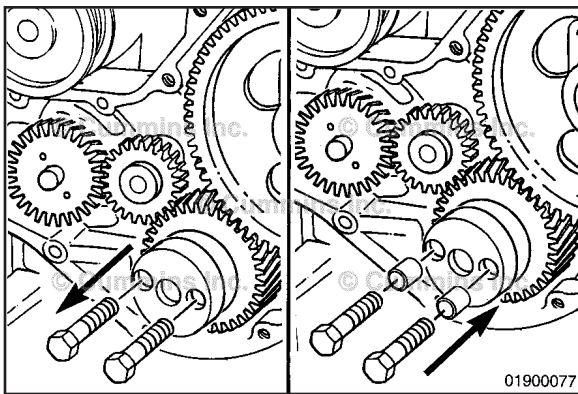

Remove the two capscrews.

Install the spacer on each capscrew.

Install the two capscrews.

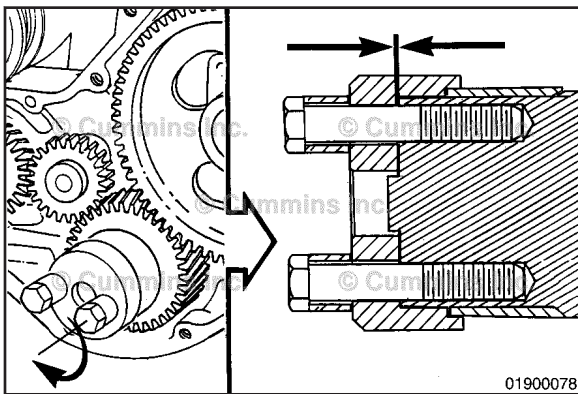

Continue to tighten the capscrews alternately until the bottom of the driver contacts the end of the crankshaft.

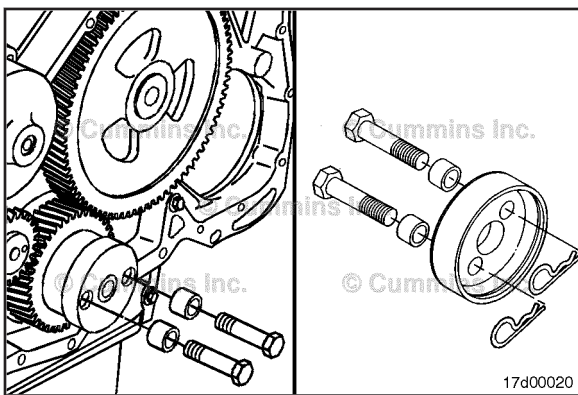

Remove the crankshaft front wear sleeve installation tool.

Finishing Steps

Front Gear Train

Install the front crankshaft seal. Refer to Procedure Procedure 001-023

Install the front gear cover. Refer to Procedure 001-031

Install the vibration damper/crankshaft speed indicator ring. If equipped with a viscous damper, Refer to Procedure 001-052. If equipped with a rubber damper, Refer to Procedure 001-051. If equipped with a crankshaft speed indicator ring only, Refer to Procedure 001-071

Install the camshaft position sensor. Refer to Procedure 019-363 in the corresponding Troubleshooting and Repair Manual.

Install the fan hub, if required. Refer to Procedure 008-039

Install the engine water pump (cooling fan) drive belt. Refer to Procedure 008-002

For marine applications, install the sea water pump drive belt, if equipped. Refer to Procedure 008-126

Install the belt guards, if equipped. Refer to Procedure 008-001

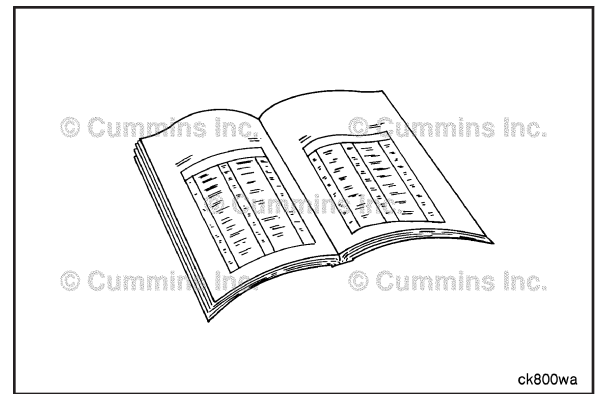

⚠️ WARNING ⚠️

Batteries can emit explosive gases. To reduce the possibility of personal injury, always ventilate the compartment before servicing the batteries. To reduce the possibility of arcing, remove the negative (-) battery cable first and attach the negative (-) battery cable last.

Connect the batteries.

Operate the engines and check for leaks.

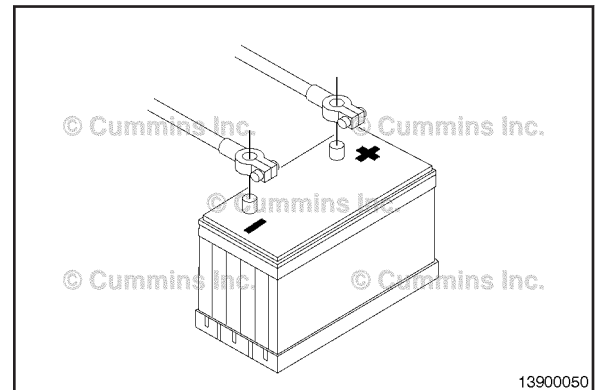

Rear Gear Train

If removed, install the front gear cover. Refer to Procedure 001-031

Install the front crankshaft seal. Refer to Procedure Procedure 001-023

Install the vibration damper/crankshaft speed indicator ring. If equipped with a viscous damper, Refer to Procedure 001-052. If equipped with a rubber damper, Refer to Procedure 001-051. If equipped with a crankshaft speed indicator ring only, Refer to Procedure 001-071

Install the engine water pump (cooling fan) drive belt. Refer to Procedure 008-002

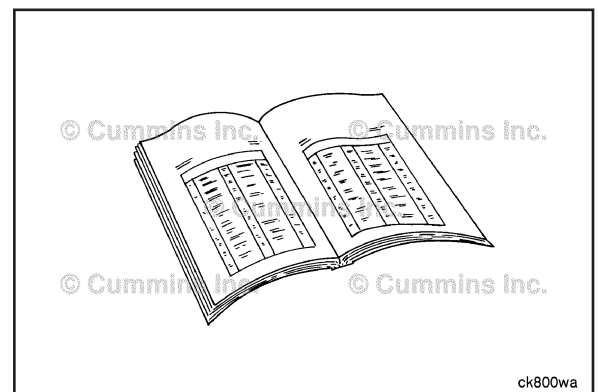

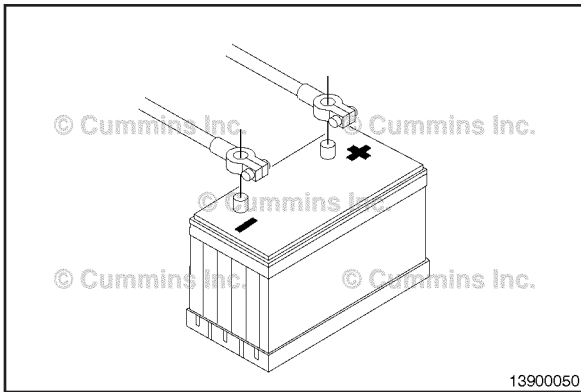

⚠ WARNING ⚠

Batteries can emit explosive gases. To reduce the possibility of personal injury, always ventilate the compartment before servicing the batteries. To reduce the possibility of arcing, remove the negative (-) battery cable first and attach the negative (-) battery cable last.

Connect the batteries.

Operate the engine and check for leaks.

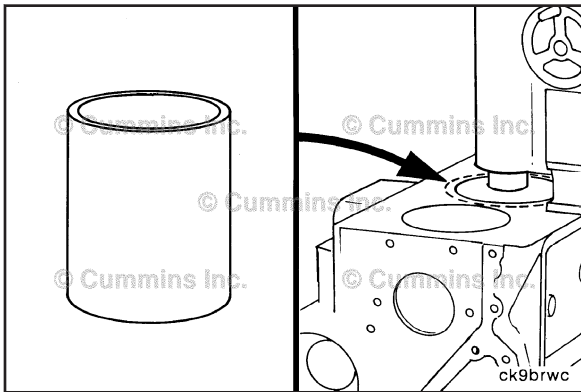

Cylinder Block (001-026)

General Information

The cylinder block uses bored cylinders as opposed to liners. In the event of damage or wear out, the cylinders may be able to be repaired.

For engines displacing 3.9L and 5.9L, the cylinders can be bored oversize twice for the use of oversize pistons and rings (0.5 mm [0.020 in] and 1 mm [0.040 in] oversize). A repair sleeve can also be installed if the cylinder bore **must** be bored more than 1 mm [0.040 in] oversize. See the Overbore and/or Repair Sleeve section of this procedure.

NOTE: For 5.9L engines with exhaust gas recirculation (EGR) and Marine applications, if boring the cylinder bores oversize or installing repair sleeves, a service specific head gasket **must** be used to make sure of proper sealing of the combustion seal.

For engines displacing 4.5 L and 6.7 L, the cylinders can **only** be bored oversize once for the use of oversize pistons and rings (0.5 mm [0.020 in] oversize). A repair sleeve can be installed if the cylinder bore **must** be bored more than 0.5 mm [0.020 in] oversize. See the Overbore section of this procedure.

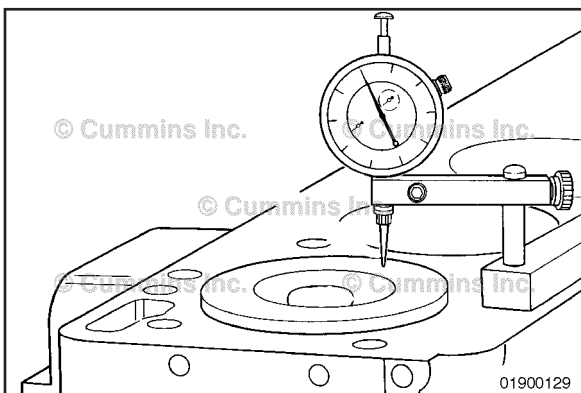

Initial Check

Prior to removing the piston and connecting rod assemblies, measure and record piston protrusion. Refer to Procedure 001-054 in Section 1.



Measuring piston protrusion prior to disassembly will aid in determining if the cylinder block, if required, can be resurfaced.

Preparatory Steps

- Remove the engine and place it on an engine stand. Refer to Procedure 000-001 in Section 0.
- Disassemble the engine. See Section DS - Engine Disassembly

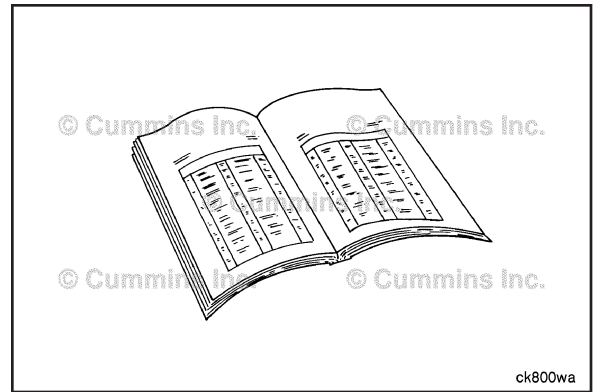

Initial Check:

Before cleaning or further disassembly of the block, perform a visual inspection to see if there is any damage (cracks, fretting, etc.) that would prohibit reuse. Pay close attention to areas of the block that include:

- Main bearing caps and bores
- Camshaft bores
- Cylinder bores
- Tappet bores
- Cylinder block combustion deck
- Oil pan mounting surface
- Lubricating oil pump mounting area
- Water pump mounting area
- Front and rear of block sealing surfaces
- Lubricating oil cooler cavity.

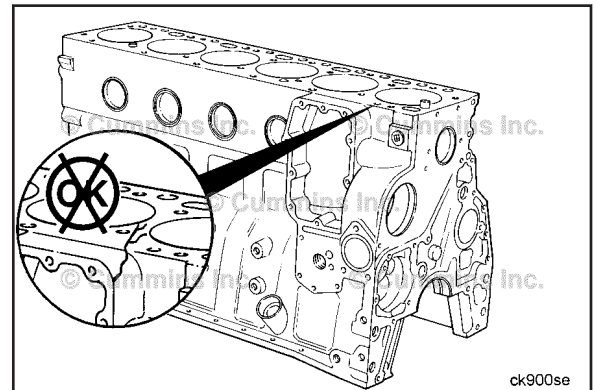

Clean and Inspect for Reuse

Inspect all pipe plugs, expansion plugs, and straight thread plugs for signs of damage or leaks.

If it is necessary to thoroughly clean the cylinder block for reuse due to excessive debris or contamination, remove all pipe plugs, expansion plugs, and straight thread plugs as necessary. Make sure all oil and coolant passages are cleaned out.

Refer to Procedure 017-002 in Section 17. Refer to Procedure 017-007 in Section 17. Refer to Procedure 017-011 in Section 17.

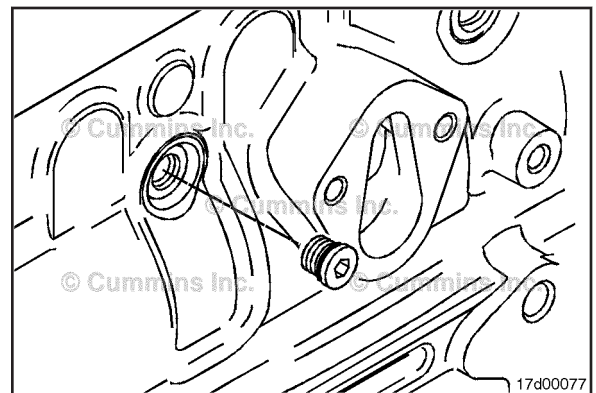

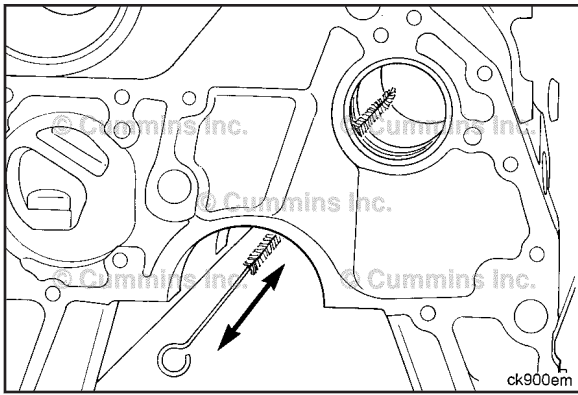

⚠ WARNING ⚠
When using solvents, acids, or alkaline materials for cleaning, follow the manufacturer's recommendations for use. Wear goggles and protective clothing to reduce the possibility of personal injury.

Use clean solvent and a nonmetallic brush to clean the block oil drillings.

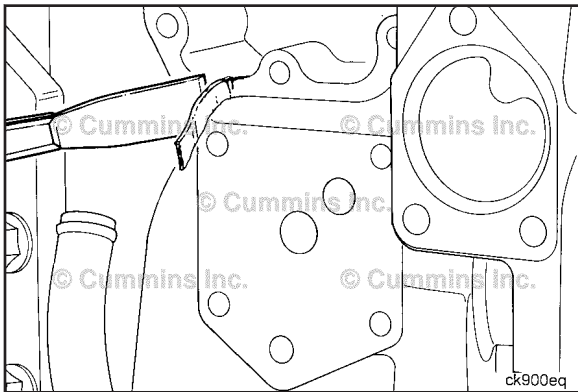

Thoroughly clean all gasket sealing surfaces of any remaining gasket residue.

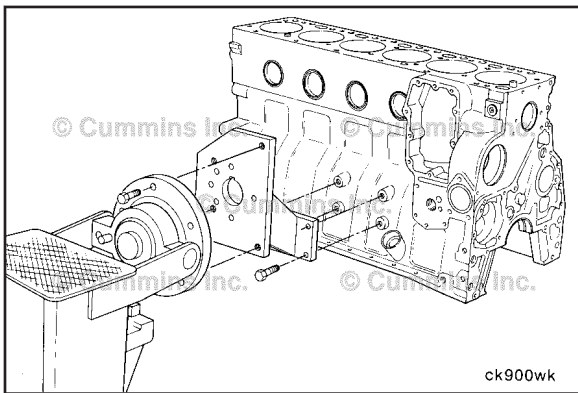

⚠ WARNING ⚠
This component or assembly weighs greater than 23 kg [50 lb]. To prevent serious personal injury, be sure to have assistance or use appropriate lifting equipment to lift this component or assembly.

Remove the block from the engine stand.

⚠ WARNING ⚠

When using solvents, acids, or alkaline materials for cleaning, follow the manufacturer's recommendations for use. Wear goggles and protective clothing to reduce the possibility of personal injury.

⚠ CAUTION ⚠

Use a cleaning solution that will not damage the camshaft bushings.

Follow the manufacturer's operating instructions for the cleaning tank.

Follow the solvent manufacturer's instructions for using the solvent.

NOTE: Cummins Inc. does **not** recommend any specific cleaning solution. Experience has shown that the best results are obtained by using a cleaning solution that can be heated from 80 to 95°C [176 to 203°F]. A cleaning tank that **will** mix and filter the cleaning solution will give the best results.

Clean the cylinder block in the cleaning tank.

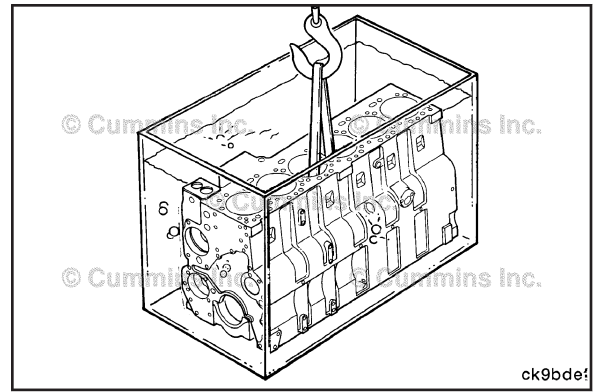

⚠ WARNING ⚠

When using a steam cleaner, wear safety glasses or a face shield, as well as protective clothing. Hot steam can cause serious personal injury.

⚠ WARNING ⚠

Wear appropriate eye and face protection when using compressed air. Flying debris and dirt can cause personal injury.

⚠ CAUTION ⚠

To reduce the possibility of engine damage, make sure all debris is removed from the capscrew holes and oil passages.

Remove the block from the cleaning tank.

Use steam to clean the cylinder block thoroughly.

Use compressed air to dry the block.

NOTE: If the cylinder block is **not** used immediately, apply a coating of preservative oil to prevent rust. Cover the block to prevent dirt from sticking to the oil.

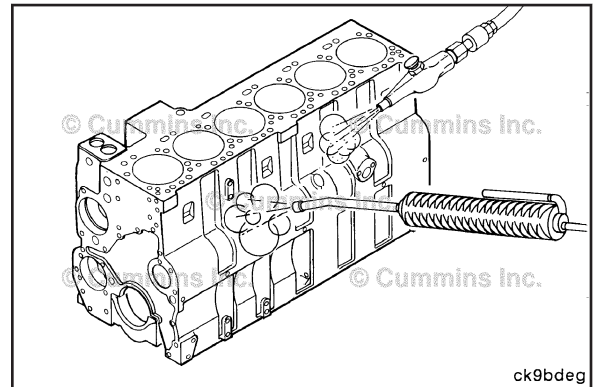

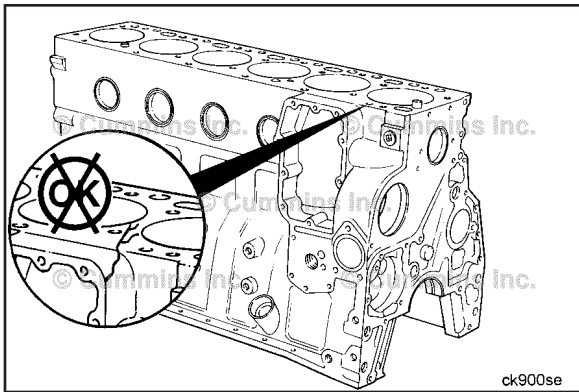

With the cylinder block cleaned, inspect the cylinder block again for signs of cracks, fretting, and discoloration that will prohibit reuse.

To help identify cracks in the cylinder block, use the Crack Detection Kit, Part Number 3375432.

Pay close attention to areas of the block that include:

- Main bearing caps and bores
- Camshaft bores
- Cylinder bores
- Tappet bores
- Cylinder block combustion deck
- Oil pan mounting surface
- Lubricating oil pump mounting area
- Water pump mounting area
- Front and rear of block sealing surfaces
- Lubricating oil cooler cavity.

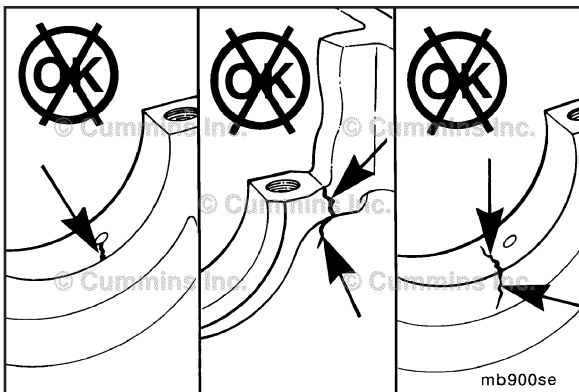

Inspect the main bearing caps and main bearing saddle areas for cracks, fretting, and signs of discoloration.

If any cracks are found, the cylinder block **must** be replaced.

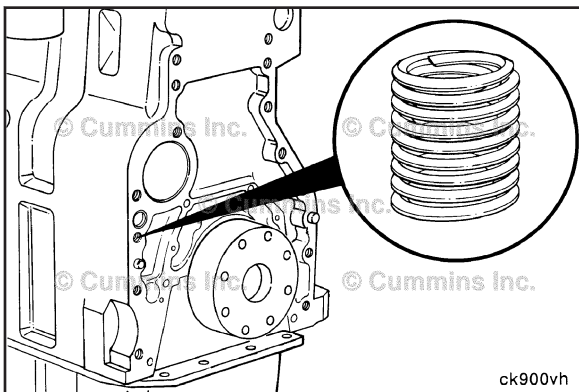

Inspect all threaded capscrew holes for damaged threads. Coiled thread inserts may be used to repair any damaged threads.

Service Tool threaded insert kits are available:

- Part Number 3377905 for standard threads
- Part Number 3377903 for metric threads.

NOTE: Coiled thread inserts **must not** be used to repair main bearing saddle threaded capscrew holes. If damaged, the block **must** be replaced.

Inspect the cylinder bores for glazing.

A surface without glaze will have a crosshatched appearance with the lines at 25- to 30-degree angles with the top of the cylinder bore.

If deglazing is required, see the Deglazing information in the Repair section of this procedure.

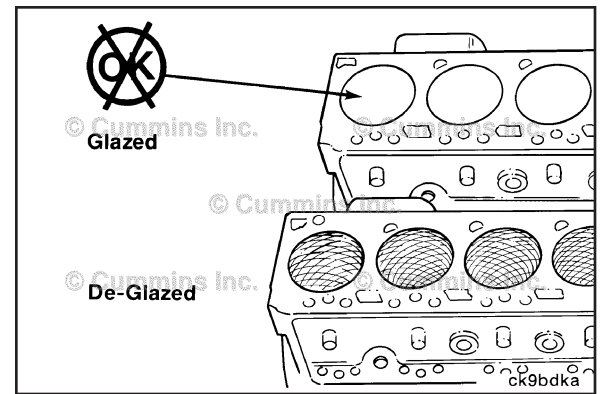

Inspect the camshaft bores for scoring, scuffing or excessive wear.

If damage to the camshaft bores is found and a camshaft bushing was **not** previously installed, machine the camshaft bores oversize to install standard camshaft bushings. See the Measure section of this procedure for specifications.

If the damage to the bore(s) is beyond machining, or if a camshaft bushing was previously installed, the block **must** be replaced. Oversize cam bushings are **not** available.

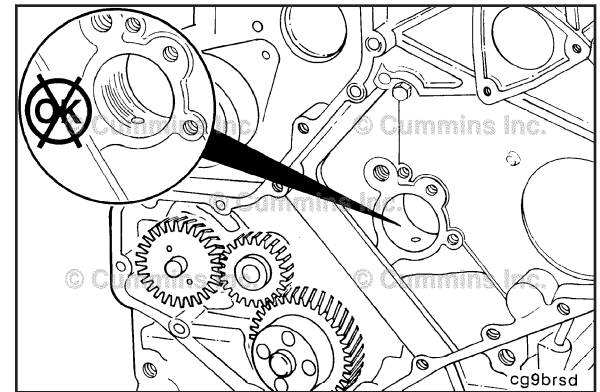

Measure

All measurements of the cylinder block **must** be made when the cylinder block is positioned on a flat surface with the main bearing caps installed, and the torque plate installed.

If the cylinder block is mounted on the engine stand and/or the main bearing caps are **not** installed, the measurements can be incorrect because of distortion. (Cylinder bores, main bearing bores, camshaft bores, etc).

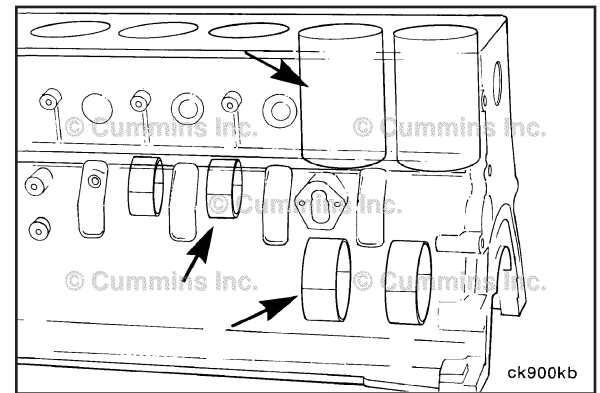

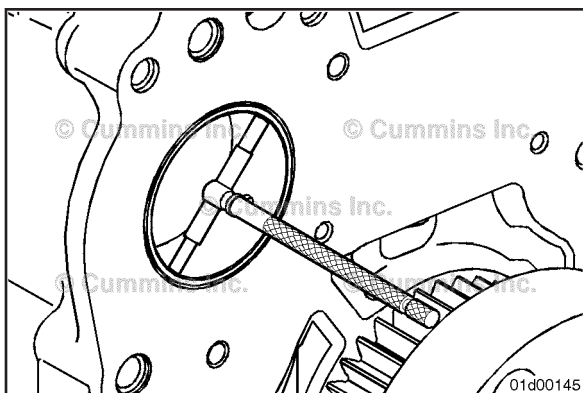

Inspect the camshaft bores without the camshaft bushing installed.



Camshaft Bore Diameter without Camshaft Installed (Maximum)

	mm		in
Camshaft Bore (Camshaft Bushing Previously Installed)	59.248	MAX	2.3326
Camshaft Bore (Camshaft Bushing not Previously Installed)	54.164	MAX	2.1324

If a camshaft bushing was previously installed and the camshaft bore is out of specification, the block **must** be replaced. Oversize cam bushings are **not** available.

If a camshaft bore in which a camshaft bushing was **not** previously installed is damaged or out of specification, the camshaft bore can be machined oversize to install a standard camshaft bushing.

Machine the damaged bore to a maximum of 59.248 mm (2.3326 in) to accept a standard bushing.

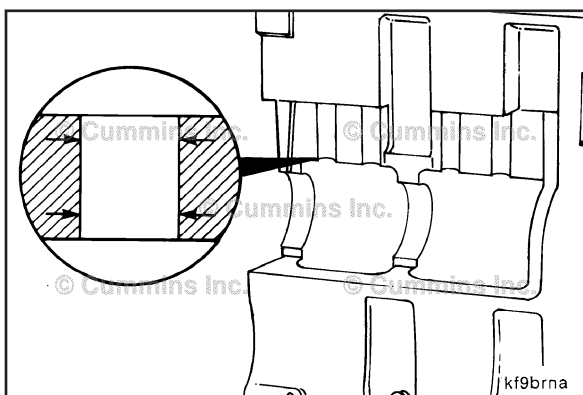

Inspect the tappet bores for scores or excessive wear.

Measure the tappet bores.



Tappet Bore Diameter

mm		in
16.000	MIN	0.630
16.055	MAX	0.632

NOTE: If the tappet bores are out of specification, the block **must** be replaced.

Install the main bearing caps without the main bearings. Refer to Procedure 001-006 in Section 1.

Tighten the main bearing cap capscrews.

Torque Value: 176 N•m [130 ft-lb]

Measure the main bearing bore with the bearings removed.

Main Bearing Bore Diameter with Bearings Removed

mm		in
87.983	MIN	3.4639
88.019	MAX	3.4653

NOTE: If the main bearing bore diameters are **not** within specification, check if the main bearing caps were installed in the proper location and orientation. If main caps are installed properly, the block **must** be replaced.

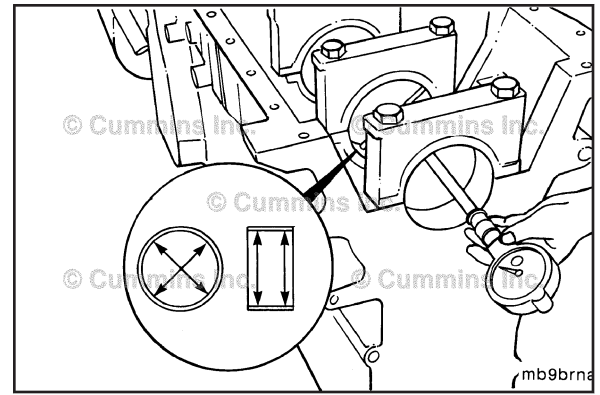

Main Bearing Capscrew Reuse Measurement

⚠ CAUTION ⚠

This step must be completed on 4.5L and 6.7L engines. Failure to check the main bearing capscrew against reuse guidelines can result in severe engine damage.

To check if a main bearing capscrew can be reused, the length **must** be measured by performing the following:

For each main bearing capscrew that has been removed, measure the length from underneath the head of the capscrew to the tip of the capscrew, as illustrated. Use one of two methods:

- 1 A depth micrometer (preferred method for accuracy)
- 2 A machinist's rule.

If the measurement is above the maximum specification, the main bearing capscrew **must** be replaced.

Main Bearing Underhead Capscrew Length

mm		in
120.00	MAX	4.724

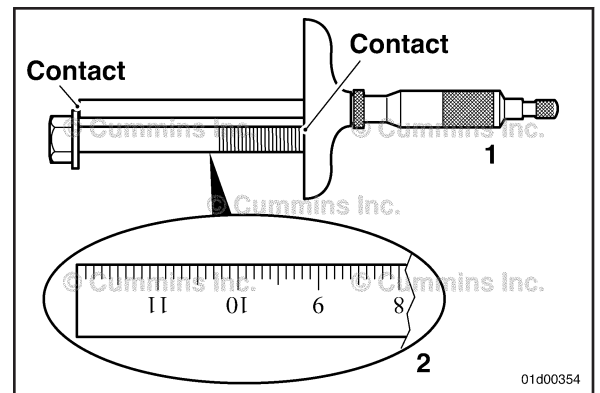

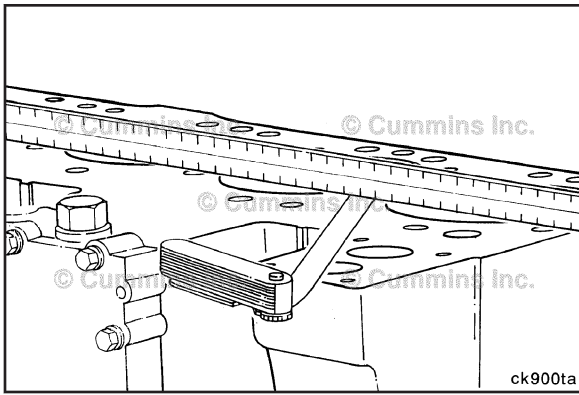

Measure the cylinder block's overall flatness.



Cylinder Block Flatness

	mm		in
End-to-End	0.076	MAX	0.003
Side-to-Side	0.051	MAX	0.002

Inspect for any localized dips or imperfections. If present, the deck **must** be resurfaced.

NOTE: The combustion deck of the block can **only** be resurfaced if one of the two following criteria are met

- 1 After the resurface, the correct piston protrusion can be achieved.
- 2 For engines that use graded head gaskets, the next thickness head gasket can be used to achieve the correct piston protrusion.

Specific head gasket with an increased thickness is **not** available for combustion deck resurfacing. If the combustion deck can **not** be resurfaced such that the correct piston protrusion can be reached, the cylinder block **must** be replaced.

3.9L and 5.9L Engines

⚠CAUTION⚠

Do not measure the bore diameter within 50 mm (1.97 in) of the block combustion deck. Inaccurate measurements will result.

NOTE: When measuring, deglazing, or boring a cylinder block, make sure all of the main bearing caps and the torque plate are in place and properly tightened. Refer to Procedure 001-006 in Section 1.

Inspect the cylinder bores for damage or excessive wear.

Use a dial bore gauge to measure the cylinder bore in four places, 90 degrees apart, at the top and bottom of the piston travel area.

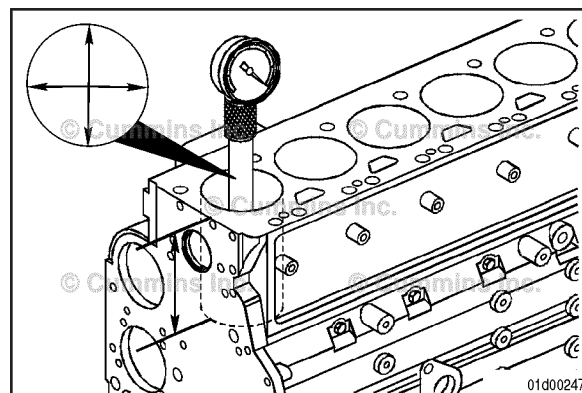

Cylinder Bore Diameter - 3.9L and 5.9L Engines Only (New Cylinder Block)

mm		in
102.010	MIN	4.0161
102.030	MAX	4.0169

Cylinder Bore Diameter - 3.9L and 5.9L Engines Only (Used Cylinder Block)

mm		in
102.010	MIN	4.0161
102.050	MAX	4.0177

Out-of-Roundness

mm		in
0.038	MAX	0.0015

Taper

mm		in
0.076	MAX	0.003

NOTE: For engines displacing 3.9L and 5.9L, the cylinders can be bored oversize twice for the use of oversize pistons and rings (0.5 mm [0.020 in] and 1 mm [0.040 in] oversize). A repair sleeve can also be installed if the cylinder bore **must** be bored more than 1 mm [0.040 in] oversize. See the Overbore and/or Repair Sleeve sections of this procedure.

⚠CAUTION⚠

Some 5.9L engines require a service specific head gasket if boring the cylinder bores oversize or installing repair sleeves. Failure to use the correct head gasket will result in engine damage.

⚠CAUTION⚠

Some 5.9L engines, require a service specific head gasket if boring the cylinder bores oversize or installing repair sleeves. The service gasket **must** be used to ensure proper sealing of the combustion seal.

To identify if a service specific head gasket is needed, visually check the previously removed head gasket. If the combustion seal has a non-circular shape, as illustrated, a service gasket **must** be used.

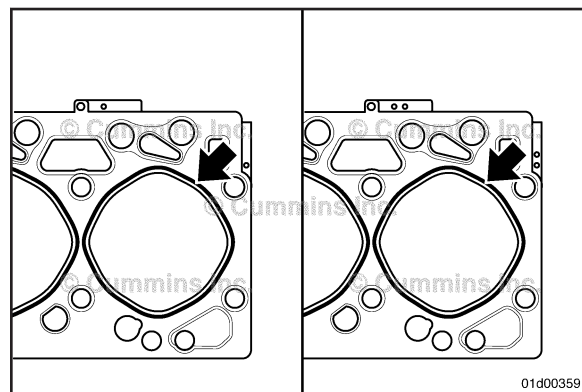

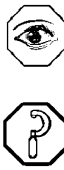
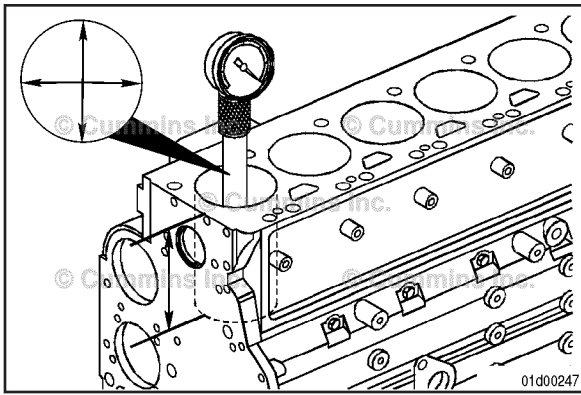

4.5L and 6.7L Engines

⚠CAUTION⚠

Do not measure the bore diameter within 50 mm (1.97 in) of the block combustion deck. Inaccurate measurements will result.

NOTE: When measuring, deglazing, or boring a cylinder block, make sure all of the main bearing caps and the torque plate are in place and properly tightened. Refer to Procedure 001-006 in Section 1.

Inspect the cylinder bores for damage or excessive wear.

Use a dial bore gauge to measure the cylinder bore in four places, 90 degrees apart, at the top and bottom of the piston travel area.

Cylinder Bore Diameter - 4.5L and 6.7L Engines Only (New Cylinder Block)

mm		in
106.990	MIN	4.2122
107.010	MAX	4.2130

Cylinder Bore Diameter - 4.5L and 6.7L Engines (Used Cylinder Block)

mm		in
106.990	MIN	4.2122
107.030	MAX	4.2138

Out-of-Roundness

mm		in
0.038	MAX	0.0015

Taper

mm		in
0.076	MAX	0.003

NOTE: For engines displacing 4.5L and 6.7L, the cylinders can **only** be bored oversize **once** for the use of oversize pistons and rings (0.5 mm [0.020 in] oversize). A repair sleeve can be installed if the cylinder bore **must** be bored more than 0.5 mm [0.020 in] oversize. See the Overbore and/or Repair Sleeve section of this procedure.

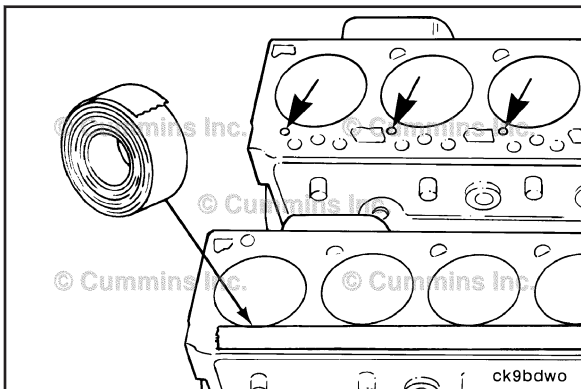

Repair

⚠CAUTION⚠

Precautions must be taken to prevent debris from any reconditioning operation from entering the lubricating oil passages of the engine. Engine damage will result.

Prior to any reconditioning of the cylinder bores, make sure to cover the lubricating holes and tappet holes in the top of the cylinder block with waterproof tape.

Deglaze:

Deglazing gives the cylinder bore the correct surface finish required to seat the piston rings. Deglazing **must only** be performed if the cylinder bores are still in specification.

NOTE: New piston rings will **not** seat in glazed cylinder bores.

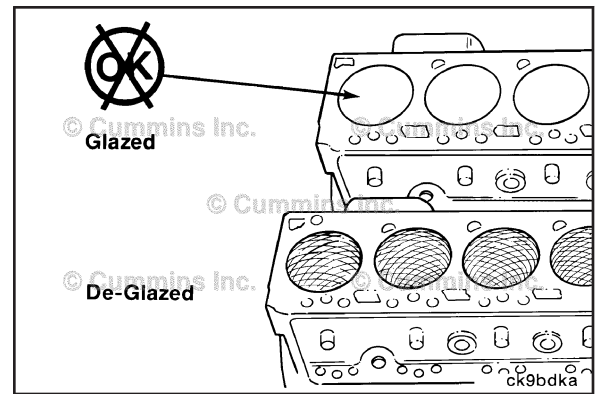

Use a ball-type hone and a rotational speed of 300 to 400 RPM with a stroke frequency of one stroke up and down per second. Make sure to use a good grade of honing oil or a mixture of equal parts SAE 30W engine oil and diesel fuel for a honing lubricant.

NOTE: Vertical strokes **must** be smooth, continuous passes along the full length of the cylinder bore.

Inspect the cylinder bore after 10 strokes.

NOTE: The crosshatch angle is a function of drill speed and how fast the hone is moved vertically. Moving too fast or too slow will give an incorrect crosshatch angle.

A correctly deglazed surface will have a crosshatched appearance with the lines at 25- to 30-degree angles with the top of the cylinder block.

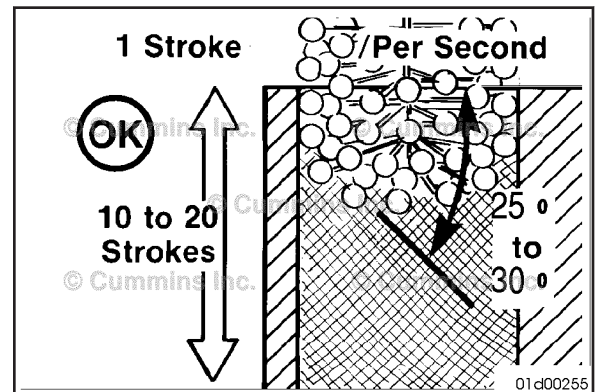

Overbore:

If the cylinder bore was found out of specification or damaged, the cylinder bore can be refinished for oversize pistons and piston rings.

Boring **must** be done by qualified personnel on a suitable boring machine. Care **must** be taken to make sure the cylinders are perpendicular to the combustion deck and within taper and out-of-round specifications for the cylinder bore.

Follow the boring machine manufacturer's recommendations for machine setup to achieve the best quality bore.

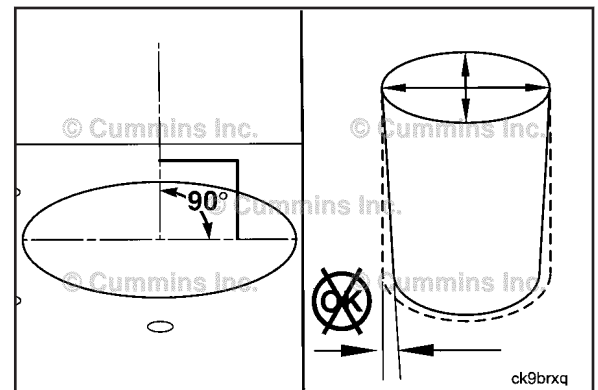

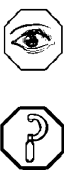
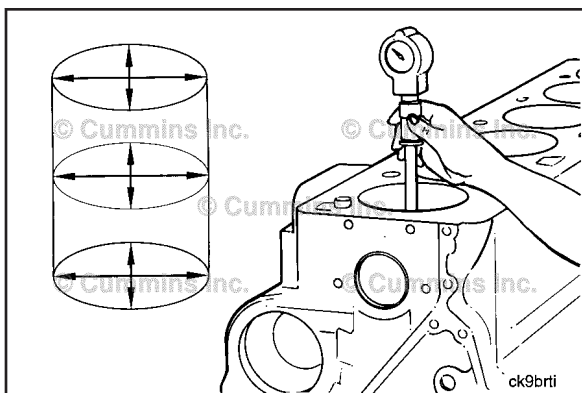

NOTE: The boring diameters given below are **not** the finished cylinder bore dimensions. The finished cylinder bore diameter will be reached through the final honing operation.

The boring diameter dimensions are as follows:

NOTE: Maximum cutting depth **must** be limited to 0.228 mm [0.009 in] per cut.

3.9L and 5.9L Bore Diameter

	mm		in
First Rebore	102.469	NOM	4.0342
Second Rebore	102.969	NOM	4.0539

B4.5 and B6.7 Engines Boring Diameter

	mm		in
Rebore	107.45	NOM	4.2303

After boring, use a honing stone to break the edge of the bore to approximately 1.25 mm [0.049 in] at 15 degrees.

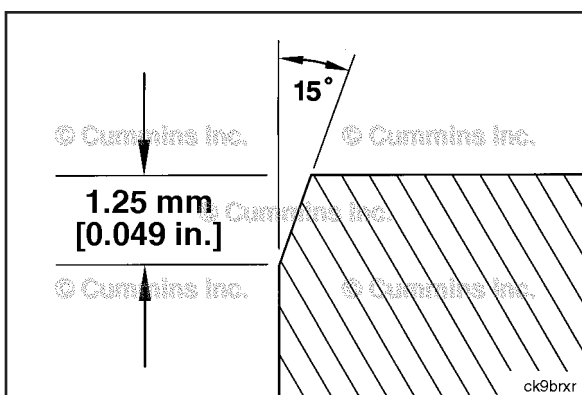

Repair Sleeve:

If more than 1.00 mm [0.0394 in] in diameter oversize bore is required for 3.9L or 5.9L engines, or if more than 0.50 mm [0.0197 in] in diameter oversize bore is required for 4.5L or 6.7L engines, the cylinder bore **must** be rebored and a repair sleeve installed. The installation of a repair sleeve will allow for the use of standard size pistons and piston rings.

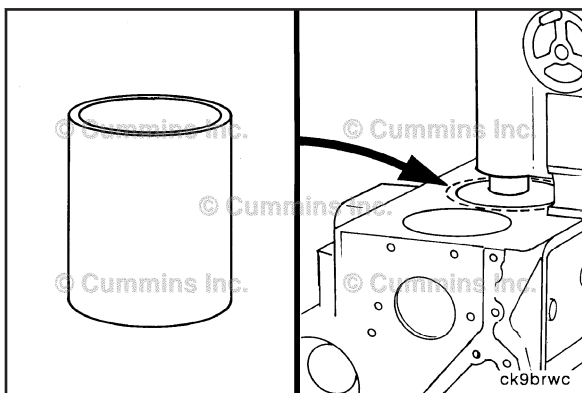

To prepare for repair sleeve installation, bore the cylinder(s) requiring a repair sleeve to:

3.9L and 5.9L Machined Bore Diameter (A)

mm		in
104.500	MIN	4.1140
104.515	MAX	4.1146

4.5L and 6.7L Machined Bore Diameter (A)

mm		in
109.700	MIN	4.3189
109.715	MAX	4.3195

To a depth of:

Cylinder Bore Depth (B)

mm		in
192.65	MAX	7.5846

This will result in a step at the bottom of the cylinder, approximately 6.35 mm [0.25 in] thick (C), against which the repair sleeve will sit.

After boring, thoroughly clean the bore of all metal chips, debris and oil before installing the repair sleeve(s).

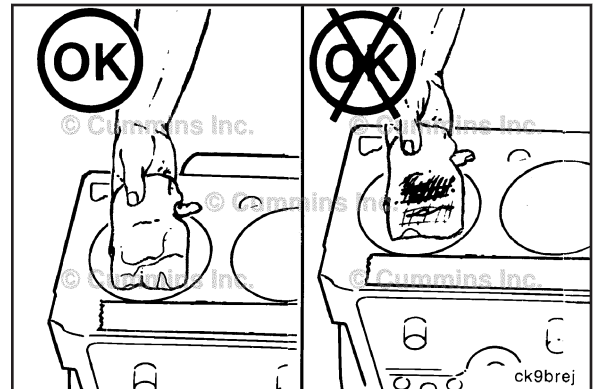
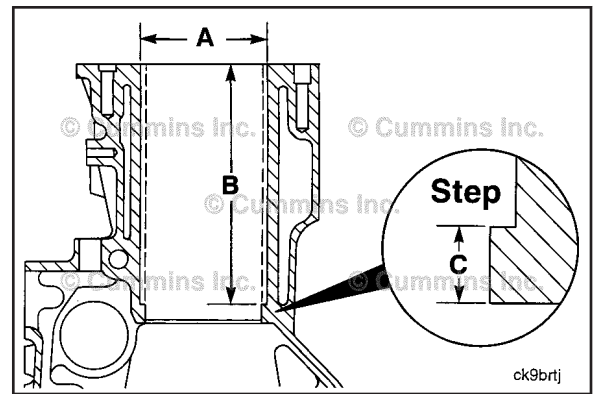

Apply a coat of Loctite® 620 to the top of the cylinder bores, as the sleeves are installed.

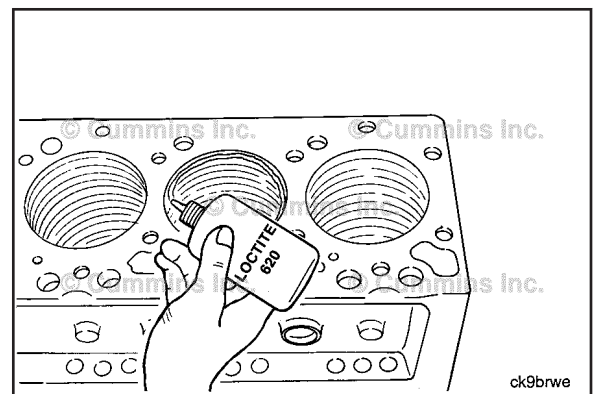

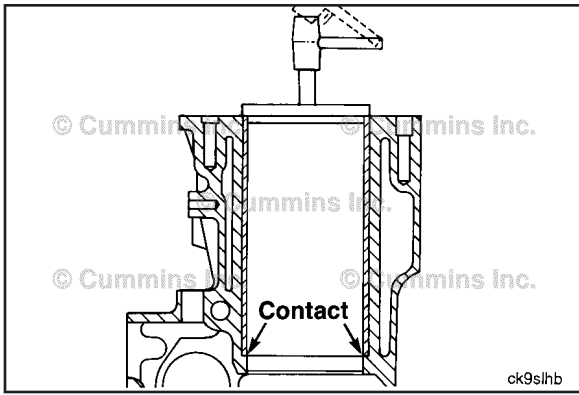

Use a sleeve driver, Part Number 3823230, for 102 mm [4.0157 in], and Part Number 2892407, for 107 mm [4.2126 in], to press or drive the repair sleeve into the cylinder bore until it contacts the step in the bottom of the bore.

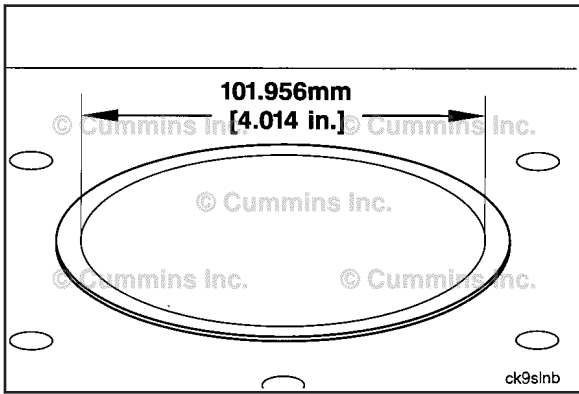

3.9L and 5.9L Series Engines

- Bore the installed sleeve to 101.956 mm [4.014 in].

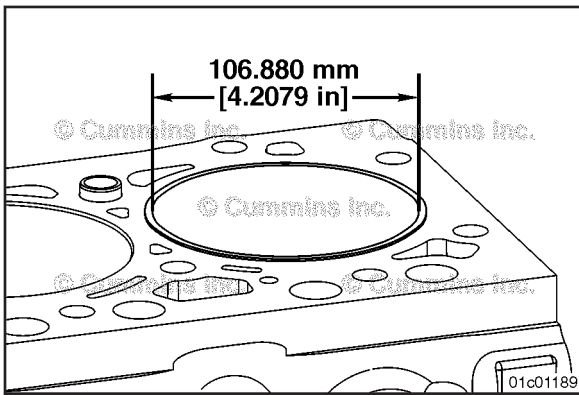

4.5L and 6.7L Series Engines

- Bore the installed sleeve to 106.880 mm [4.2079 in].

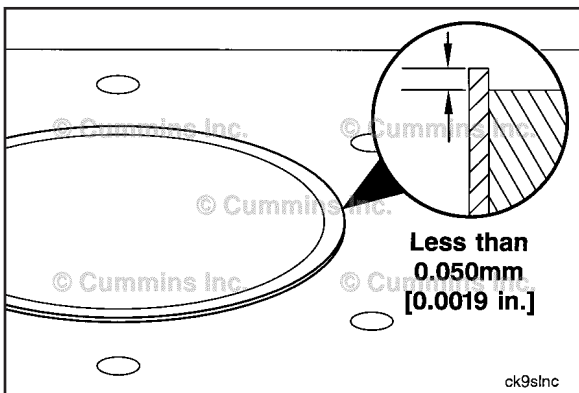

Machine the top of the sleeve to less than 0.050 mm [0.0019 in] protrusion above the combustion deck.

After boring, use a honing stone to break the edge of the bore to approximately 1.25 mm [0.049 in] at 15 degrees.

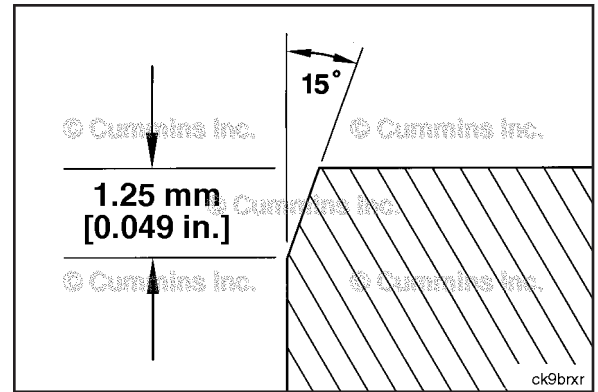

After boring a cylinder oversize or boring a repair sleeve, the cylinder requires a two stage honing process to finish the cylinder bores. It is recommended that quality equipment intended for honing engine cylinder bores be used.

NOTE: Use of a ball-type hone is **only** recommended for refinishing cylinder walls that do need reboring and/or the installation of a repair sleeve.

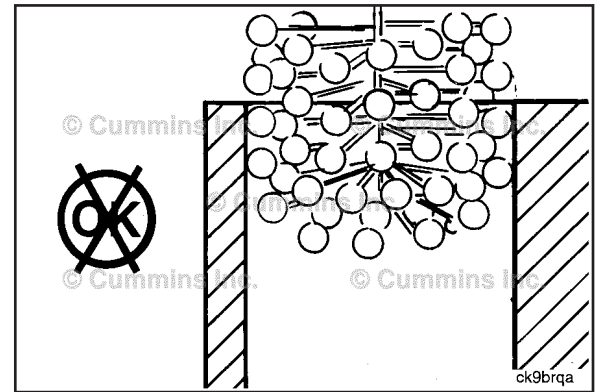

A correctly finished cylinder bore surface will have a crosshatched appearance with the lines at 25- to 30-degree angles with the top of the cylinder block.

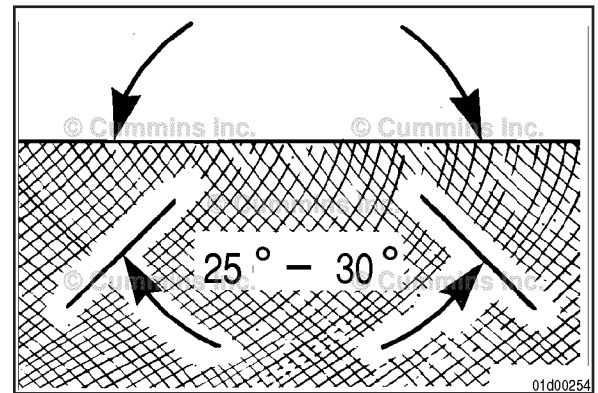

After deglazing/finishing honing, use a strong solution of hot water and laundry detergent to clean the cylinder bores.

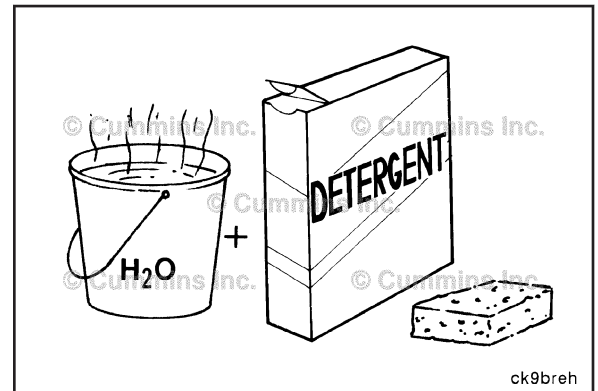

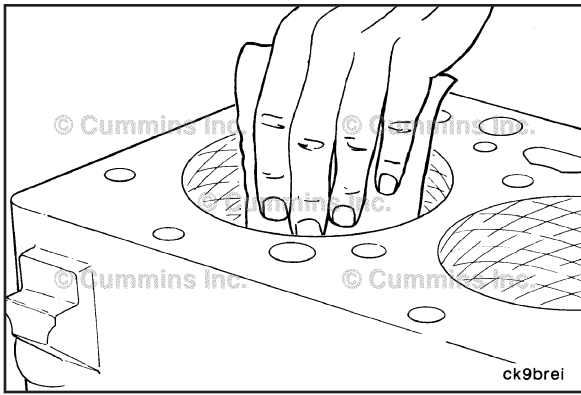

⚠ WARNING ⚠

Wear appropriate eye and face protection when using compressed air. Flying debris and dirt can cause personal injury.

⚠ CAUTION ⚠

Clean the cylinder bores immediately after deglazing/finish honing. Failure to do so can result in engine damage.

Rinse the cylinder bores until the detergent is removed.

Dry the cylinder block with compressed air.

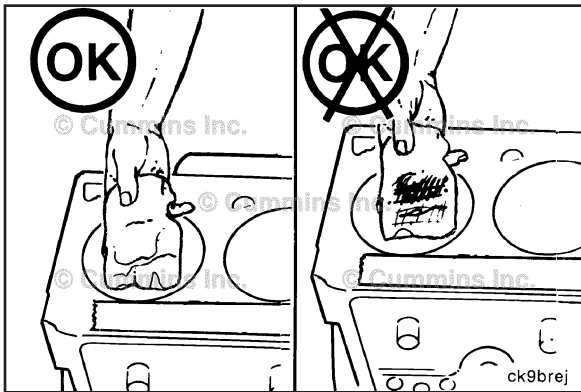

⚠ WARNING ⚠

Wear appropriate eye and face protection when using compressed air. Flying debris and dirt can cause personal injury.



⚠ WARNING ⚠

When using solvents, acids, or alkaline materials for cleaning, follow the manufacturer's recommendations for use. Wear goggles and protective clothing to reduce the possibility of personal injury.

⚠ CAUTION ⚠

Be sure to remove the tape covering the tappet holes after the cleaning process is completed. Failure to do so can result in engine damage.

Check the cylinder bore cleanliness by wiping with a white, lint-free, lightly oiled cloth. If grit residue is still present, repeat the cleaning process until all residue is removed.

Wash the cylinder bores with solvent. Dry the cylinder block with compressed air.

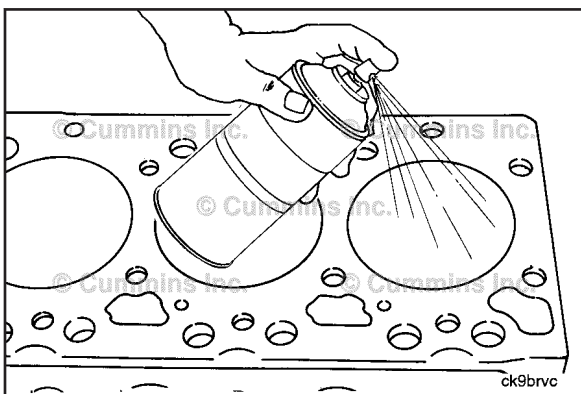

If the cylinder block is **not** to be used right away, coat all machined surfaces with a rust preventative solvent.

Make sure to cover the cylinder block to prevent dust and debris from collecting on and in the cylinder block.

If replacing the cylinder block or using a previously stored cylinder block, make sure to clean any oil/rust preventative solvent from the cylinder bores, gasket sealing areas, and main bearing bores prior to use.

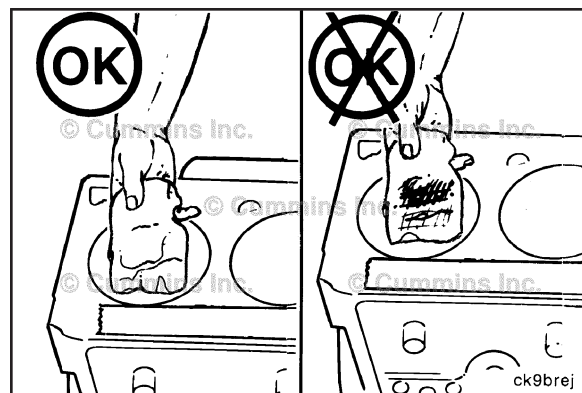

Honing Process for B3.9, B4.5, and B5.9 Engines

Use a honing rotational speed of 300 to 400 RPM with a stroke frequency of 1 stroke up and down per second. Make sure to use a good grade of honing oil. For the first stage honing, or rough honing, use a soft (fast cutting) 80 grit silicone carbide stone.hone the cylinders to their final size during this stage of honing.

For the second stage honing, or finish honing, use a medium hardness 285 grit silicone carbide stone.hone the cylinder(s) for 15 to 20 strokes to apply the appropriate crosshatch.

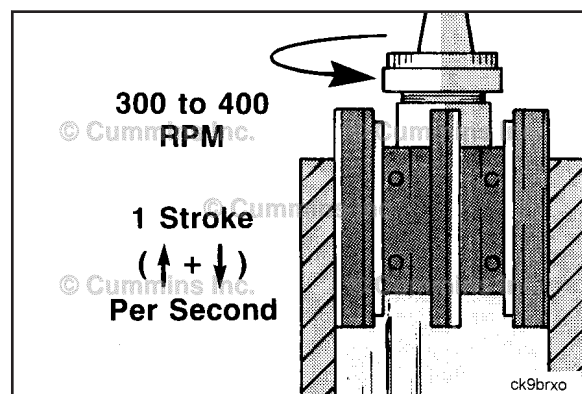

Honing Diameter Dimensions B3.9, B4.5, and B5.9 Series Engines

	mm		in
Standard Bore/Repair Sleeve	102.000	MIN	4.0157
	102.040	MAX	4.0173
First Rebore	102.500	MIN	4.0354
	102.540	MAX	4.0370
Second Rebore	103.000	MIN	4.0551
	103.040	MAX	4.0567

Honing Diameter Dimensions B4.5 RGT and B6.7 Series Engines

	mm		in
Standard Bore/Repair Sleeve	106.990	MIN	4.2122
	107.010	MAX	4.2130
Rebore	107.490	MIN	4.2319
	107.510	MAX	4.2327

Honing Process for B6.7 and B4.5 RGT Engines

For the first stage honing, or rough honing, use a 160 grit diamond honing stone.hone the cylinders to 106.9873 [4.2120 in] maximum diameter.

For the second stage honing, or finish honing, use a 280 grit silicon carbide stone.hone the cylinders to 106.990 mm [4.2122 in] minimum diameter (107.000 mm [4.2125 in] maximum diameter). Use a Plateau Honing Tools (PHT) brush for 10 to 12 strokes.

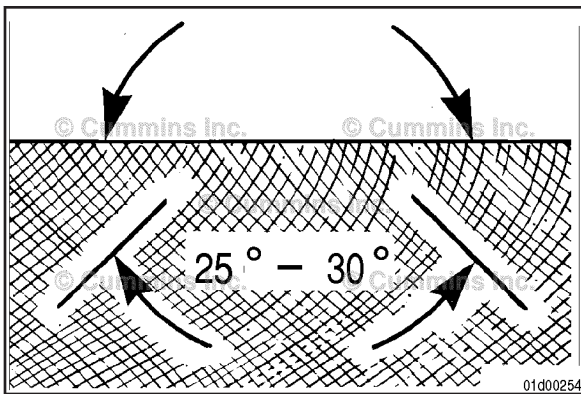

A correctly finished cylinder bore surface will have a crosshatched appearance with the lines at 25- to 30-degree angles with the top of the cylinder block.

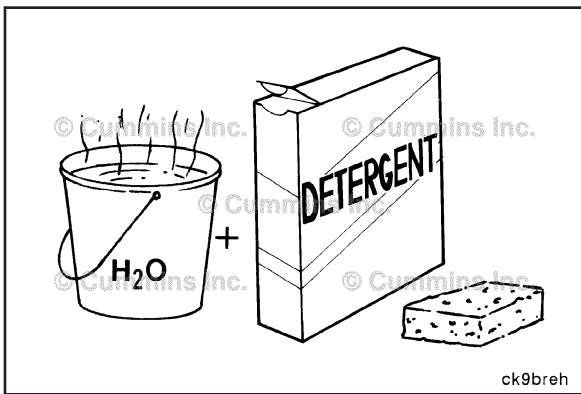

After deglazing/finishing honing, use a strong solution of hot water and laundry detergent to clean the cylinder bores.

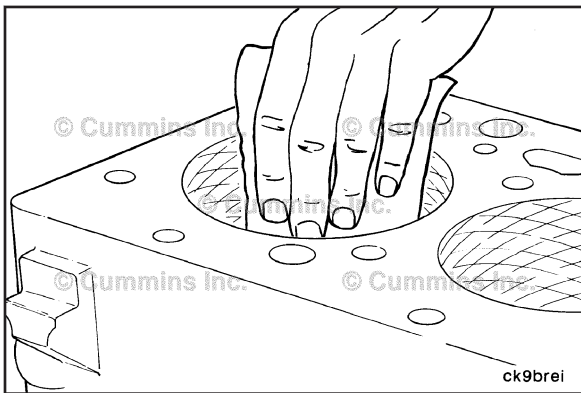

⚠ WARNING ⚠

Wear appropriate eye and face protection when using compressed air. Flying debris and dirt can cause personal injury.

⚠ CAUTION ⚠

Clean the cylinder bores immediately after deglazing/finish honing. Failure to do so can result in engine damage.

Rinse the cylinder bores until the detergent is removed.

Dry the cylinder block with compressed air.

⚠ WARNING ⚠

Wear appropriate eye and face protection when using compressed air. Flying debris and dirt can cause personal injury.

⚠ WARNING ⚠

When using solvents, acids, or alkaline materials for cleaning, follow the manufacturer's recommendations for use. Wear goggles and protective clothing to reduce the possibility of personal injury.

⚠ CAUTION ⚠

Be sure to remove the tape covering the tappet holes after the cleaning process is completed. Failure to do so can result in engine damage.

Check the cylinder bore cleanliness by wiping with a white, lint-free, lightly oiled cloth. If grit residue is still present, repeat the cleaning process until all residue is removed.

Wash the cylinder bores with solvent. Dry the cylinder block with compressed air.

If the cylinder block is **not** to be used right away, coat all machined surfaces with a rust preventative solvent.

Make sure to cover the cylinder block to prevent dust and debris from collecting on and in the cylinder block.

If replacing the cylinder block or using a previously stored cylinder block, make sure to clean any oil/rust preventative solvent from the cylinder bores, gasket sealing areas, and main bearing bores prior to use.

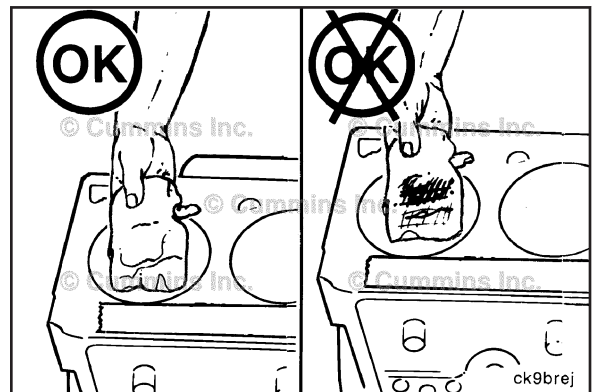
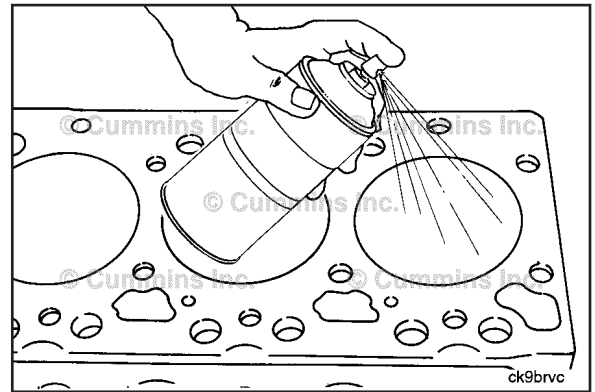
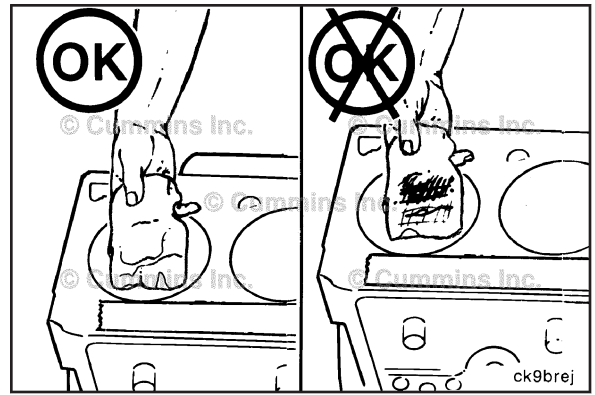
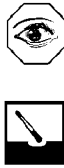

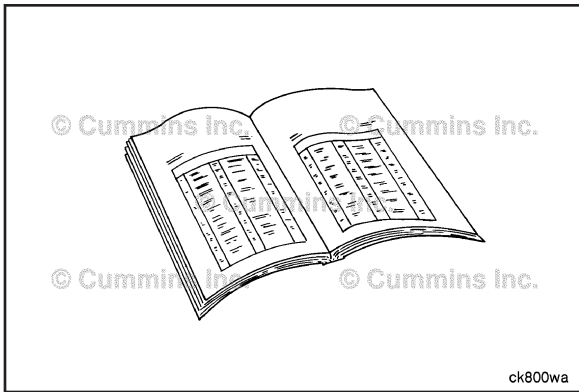

Finishing Steps



- Assemble the engine. See Section AS - Engine Assembly.
- Remove the engine from the stand and install the engine. Refer to Procedure 000-002 in Section 0.

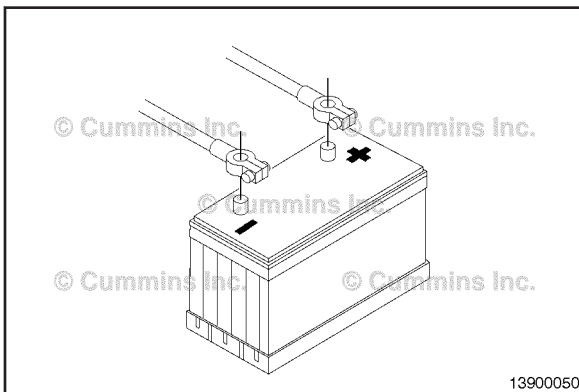

Gear Cover, Front (001-031)

Preparatory Steps

Rear Gear Train

⚠ WARNING ⚠

Batteries can emit explosive gases. To reduce the possibility of personal injury, always ventilate the compartment before servicing the batteries. To reduce the possibility of arcing, remove the negative (-) battery cable first and attach the negative (-) battery cable last.

Disconnect the batteries.

Remove the engine water pump (cooling fan) drive belt. Refer to Procedure 008-002 in Section 8.



Remove the vibration damper/crankshaft speed indicator ring. Use the following procedure if equipped with a viscous damper. Refer to Procedure 001-052 in Section 1. Use the following procedure if equipped with a rubber damper. Refer to Procedure 001-051 in Section 1. Use the following procedure if equipped with a crankshaft speed indicator ring **only**. Refer to Procedure 001-071 in Section 1.



If required, remove the fan hub pulley. Refer to Procedure 008-039 in Section 8.

Remove the front seal. Refer to Procedure 001-023 in Section 1.

Disconnect and remove the camshaft position sensor, if required. Use the following procedure in the ISB, ISB^e4, QSB4.5, QSB5.9, QSB6.7, ISC, QSC8.3, ISL, and QSL9 Engines Electronic Control System, Troubleshooting and Repair Manual, Bulletin 4021416. Refer to Procedure 019-363 in Section 19.

Disconnect and remove the crankshaft position/speed sensor, if required. Use the following procedure in the ISB, ISB^e4, QSB4.5, QSB5.9, QSB6.7, ISC, QSC8.3, ISL, and QSL9 Engines Electronic Control System, Troubleshooting and Repair Manual, Bulletin 4021416. Refer to Procedure 019-365 in Section 19. Use the following procedure in the Electronic Control System ISB (4 cylinder) and ISB^e (4 and 6 cylinder) Series Engines Troubleshooting and Repair Manual, Bulletin 3666477. Refer to Procedure 019-042 in Section 19.

If the oil pressure sensor/switch is located in the front gear cover, disconnect and remove the sensor/switch. Use the following procedure in the ISB, ISB^e4, QSB4.5, QSB5.9, QSB6.7, ISC, QSC8.3, ISL, and QSL9 Engines Electronic Control System, Troubleshooting and Repair Manual, Bulletin 4021416. Refer to Procedure 019-066 in Section 19.

Front Gear Train



Batteries can emit explosive gases. To reduce the possibility of personal injury, always ventilate the compartment before servicing the batteries. To reduce the possibility of arcing, remove the negative (-) battery cable first and attach the negative (-) battery cable last.

Disconnect the batteries.

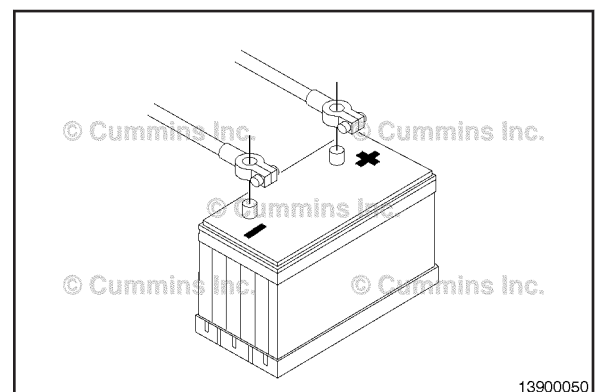
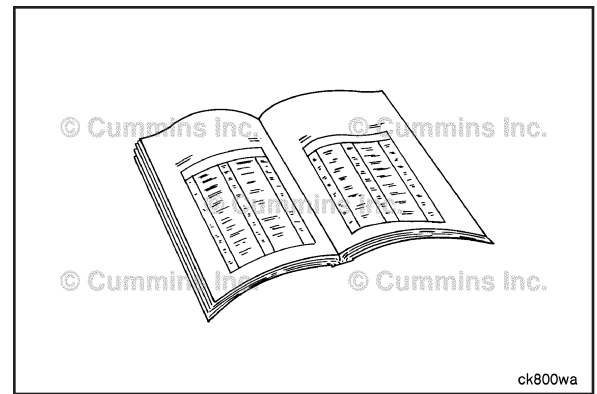

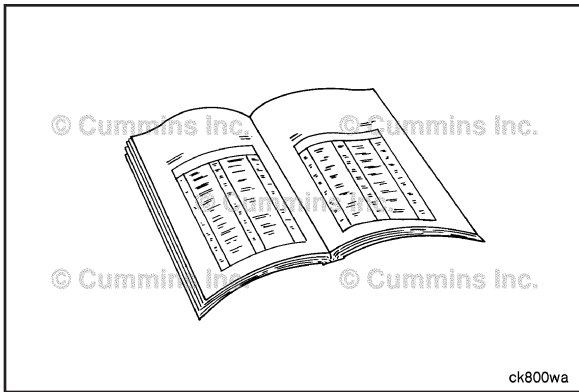

Remove the belt guards, if required. Refer to Procedure 008-001 in Section 8.



For marine applications, remove the sea water pump drive belt. Refer to Procedure 008-126 in Section 8.

Remove the engine water pump (cooling fan) drive belt. Refer to Procedure 008-002 in Section 8.

If required, remove the fan hub. Refer to Procedure 008-039 in Section 8.

Disconnect and remove the crankshaft position sensor. Use the following procedure in the ISB, ISB^e4, QSB4.5, QSB5.9, QSB6.7, ISC, QSC8.3, ISL, and QSL9 Engines Electronic Control System, Troubleshooting and Repair Manual, Bulletin 4021416. Refer to Procedure 019-365 in Section 19.

Remove the vibration damper/crankshaft speed indicator ring. Use the following procedure if equipped with a viscous damper. Refer to Procedure 001-052 in Section 1. Use the following procedure if equipped with a rubber damper. Refer to Procedure 001-051 in Section 1. Use the following procedure if equipped with a crankshaft speed indicator ring **only**. Refer to Procedure 001-071 in Section 1.

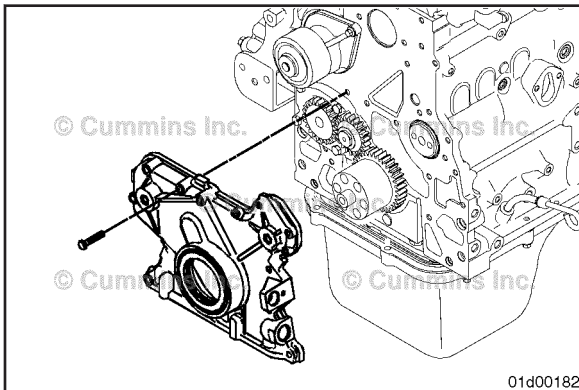

Remove Rear Gear Train

⚠CAUTION⚠

Some rear gear train engines, with a cast aluminum front gear cover, have two threaded holes to aid in the removal of the front gear cover. When looking at the front of the front gear cover, there is a threaded through hole in the lower right-hand corner that can be used with a jackscrew. On the lower left-hand corner, there is a threaded blind hole. A cap screw can be inserted into that blind hole to be used with a slide hammer. Do not use the lower left-hand threaded blind hole as a jackscrew or the front gear cover will be damaged.

Remove the front gear cover mounting capscrews.

⚠CAUTION⚠

To break the seal, pry the front gear cover away from the front gear housing. Be careful not to damage the front gear cover when breaking the seal to the front gear housing.

Remove the front gear cover.

Front Gear Train

⚠ CAUTION ⚠

To break the seal, pry the front gear cover away from the front gear housing. Be careful not to damage the front gear cover when breaking the seal to the front gear housing.

Remove the front gear cover mounting capscrews.

Remove the front gear cover with the front crankshaft seal.

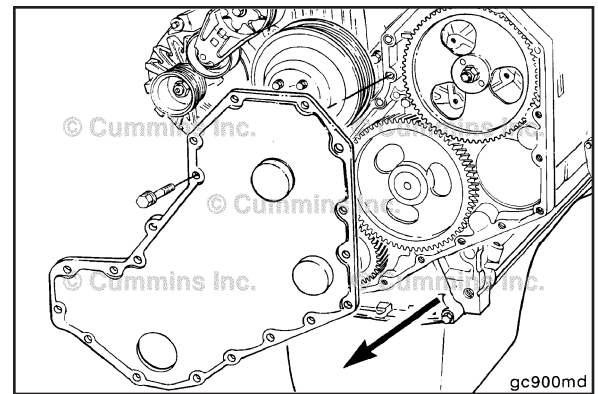

Support the front gear cover on a flat work surface with wooden blocks. Using a suitable punch and hammer, drive the old seal out of the front gear cover from the back side of the cover to the front side.

NOTE: Some engines have an additional dust seal installed in front of the front crankshaft seal.

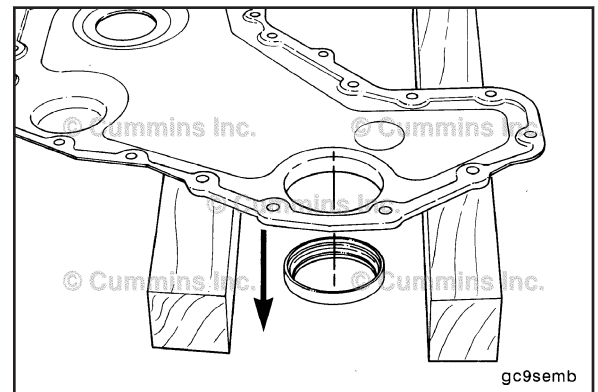

Clean and Inspect for Reuse

⚠ WARNING ⚠

When using solvents, acids, or alkaline materials for cleaning, follow the manufacturer's recommendations for use. Wear goggles and protective clothing to reduce the possibility of personal injury.

⚠ WARNING ⚠

When using a steam cleaner, wear safety glasses or a face shield, as well as protective clothing. Hot steam can cause serious personal injury.

⚠ WARNING ⚠

Wear appropriate eye and face protection when using compressed air. Flying debris and dirt can cause personal injury.

Scrape the sealant from the front gear cover and gear housing surface, for front gear train engines, or the cylinder block, for rear gear train engines.

Use solvent or steam to clean the front gear cover.

Dry the cover with compressed air.

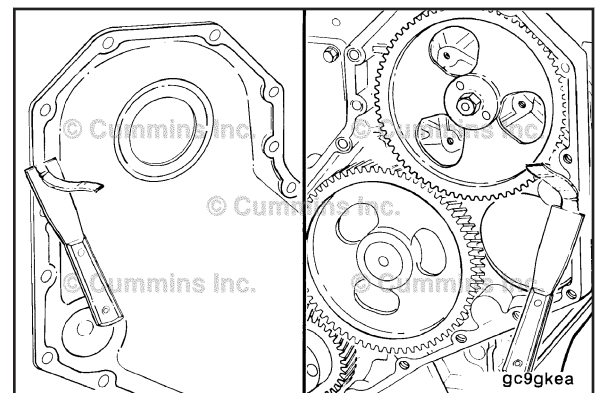

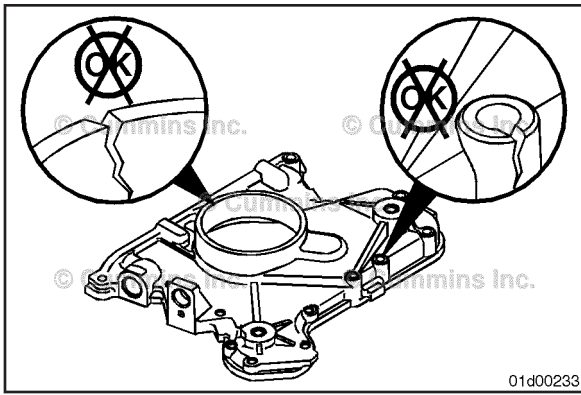

Inspect the gear cover for cracks or damage.

Replace the front gear cover if **any** damage is found.

NOTE: Parts from the damaged front gear cover can be used again when replacing the front gear cover. Examples are the oil fill neck, fuel pump gear access plate, etc.

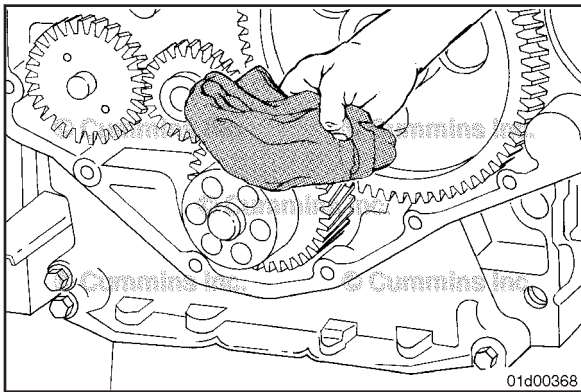

▲ WARNING ▲

When using solvents, acids, or alkaline materials for cleaning, follow the manufacturer's recommendations for use. Wear goggles and protective clothing to reduce the possibility of personal injury.

▲ WARNING ▲

Wear appropriate eye and face protection when using compressed air. Flying debris and dirt can cause personal injury.

Use solvent to clean the oil and seal residue from the crankshaft surface.

Dry with compressed air.

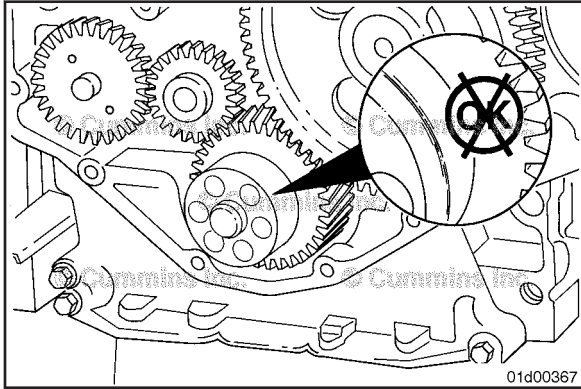

NOTE: If the crankshaft has excessive wear, a service wear sleeve is available for engines that use a lip style front crankshaft seal.

Inspect the nose of the crankshaft for excessive wear.

For engines equipped with a non-lip style front crankshaft seal, use a fine crocus cloth to remove any nicks or burrs. There is **no** wear sleeve available if the crankshaft nose sealing surface is damaged.

For engines equipped with a lip style front crankshaft seal, inspect the crankshaft seal contact area for a wear groove. If the groove is deeper than 0.25 mm [0.010 in], a wear sleeve and oversize seal **must** be used. Refer to Procedure 001-025 in Section 1.

Install

Rear Gear Train

Oil Pan Suspended - Rubber Gasket

Inspect the oil pan gasket for damage.

If the engine is equipped with a suspended oil pan with a rubber oil pan gasket and the gasket is found to be damaged, the oil pan **must** be removed and the entire oil pan gasket replaced. Refer to Procedure 007-025 in Section 7.

Oil Pan - Formed in Place Gasket

Remove the old sealant and apply new sealant, Part Number 3164070, to the oil pan mounting flange.

Oil Pan, Standard - Paper Gasket

Inspect the oil pan gasket for damage.

If the paper gasket is torn, it can be repaired.

Cut the torn gasket off even with the front of the cylinder block.

NOTE: Install three guide pins, Part Number 3164977, to improve alignment of the front cover and front seal to the gear housing and crankshaft.

Use the old gasket as a pattern to cut the front section of the new gasket to the same size.

NOTE: The front gear cover **must** be installed within 10 minutes of applying the sealant.

Clean the sealing surfaces.

Coat the new gasket on both sides with sealant, Part Number 3164067.

Make sure there is a bead of sealant at the intersecting joint of the cylinder block, oil pan, and front gear cover.

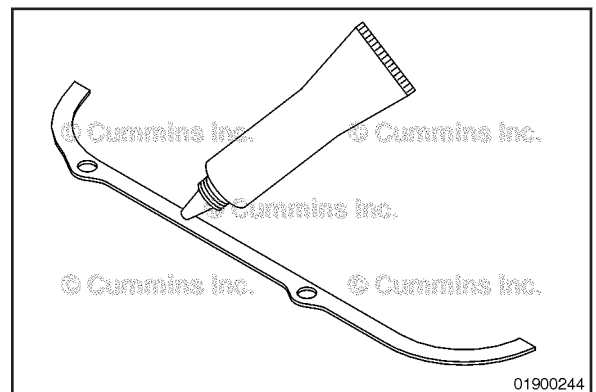
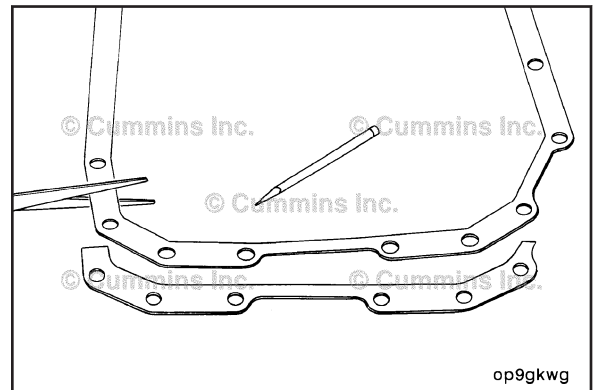
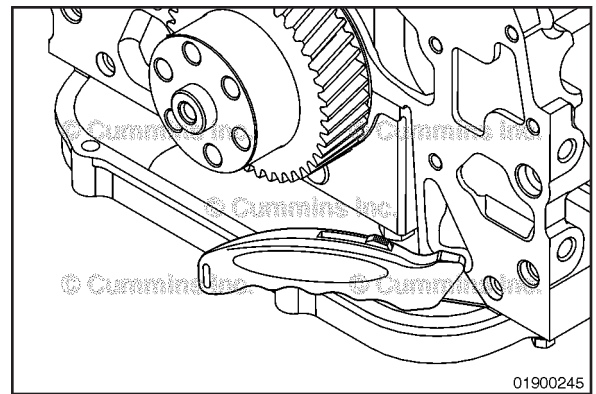

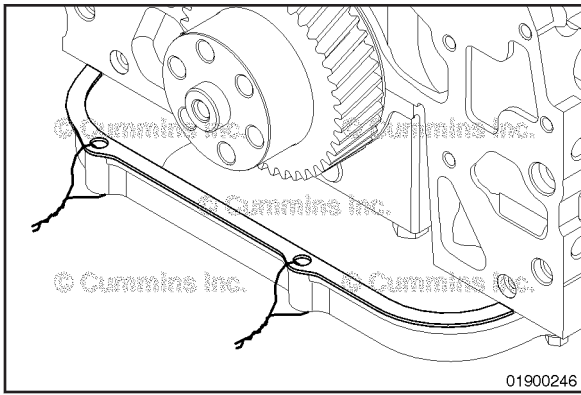

Use common thread or very fine wire to hold the gasket splice in position as illustrated.

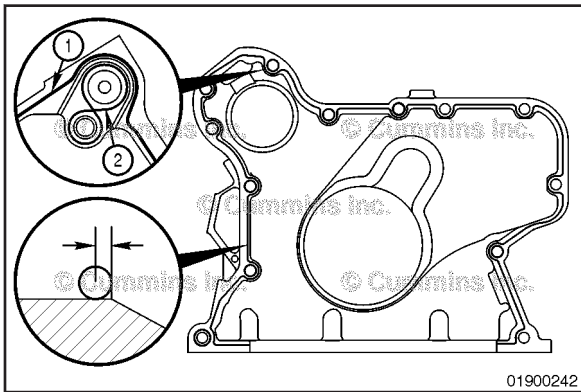

⚠ CAUTION ⚠

When applying sealant to engines that have an oil pressure sensor/switch mounted in the front gear cover, do **NOT** block the oil feed between the cylinder block and front gear cover with sealant. This will result in the ECM indicating a low oil pressure fault and possible engine shutdown.



Apply a 1.5 to 2.0 mm [0.06 to 0.08 in] wide bead of sealant, Part Number 3164070, to the block side of the front gear cover in the path illustrated.

On engines equipped with an oil pressure sensor/switch located in the front gear cover, there are two critical sealant paths that **must** be followed:

1. In this area, the sealant **must** be applied towards the outer edge of the front gear cover to avoid an unused mounting hole in the cylinder block.

NOTE: To make sure the unused mounting hole in the cylinder block does not affect the sealing joint, fill the mounting hole with sealant, Part Number 3164070.

2. Sealant **must** be applied around both the mounting hole location, and the oil supply hole in the front gear cover.

NOTE: Install the front cover within 10 minutes of applying the sealant, or the sealant will **not** seal correctly. Once installed, allow the sealant to dry for 30 minutes before operating the engine.

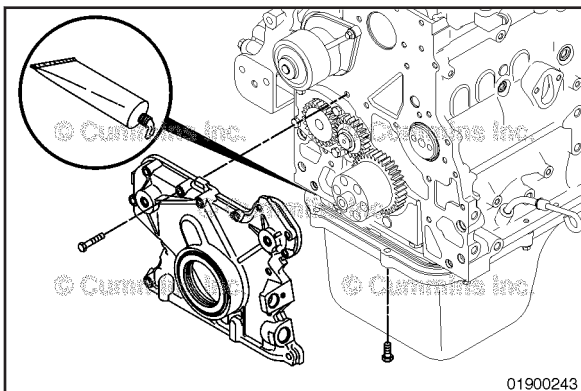

NOTE: Before installing the front gear cover, make sure sealant, Part Number 3164067, has been applied to the intersecting joint of the cylinder block, oil pan, and front gear cover.

Use the dowel rings to locate the front gear cover and install the front gear cover onto the cylinder block.

Install the front gear cover to the cylinder block mounting capscrews and the oil pan to the front gear cover mounting capscrews. Do **not** tighten the capscrews at this time.

If installed, remove the thread or wire holding the oil pan paper gasket in place.

Tighten the front gear cover to the cylinder block mounting capscrews in the order indicated.



Tighten the oil pan to front gear cover mounting capscrews, starting with the inner capscrews first.



NOTE: Depending on the type of lubricating oil pan, there are two or four mounting capscrews.

Torque Value: 24 N•m [212 in-lb]

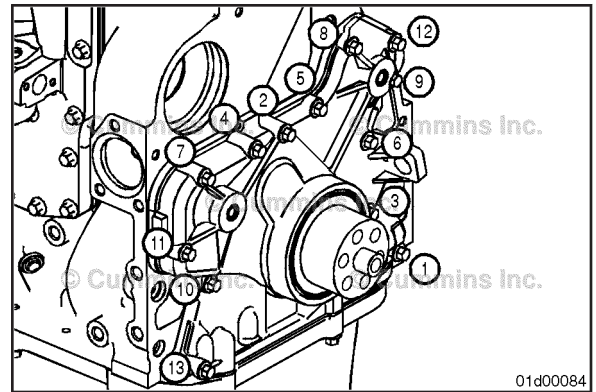

01d00084

Front Gear Train

Install a new front crankshaft seal into the front gear cover prior to installing the front gear cover.



Leave the plastic pilot installation tool in the front crankshaft seal.

Position the seal on the seal installation tool, Part Number 3824498, with the seal dust lip facing outward.

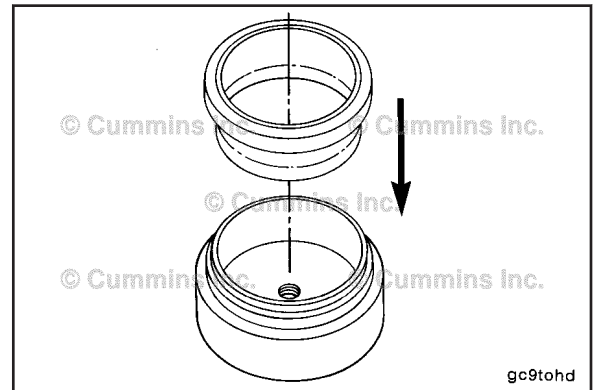

gc9tohd

Apply a bead of sealant, Part Number 3375068, to the outside circumference of the seal.

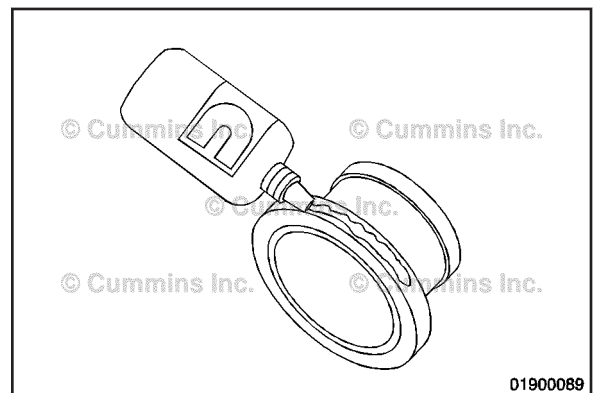

01900089

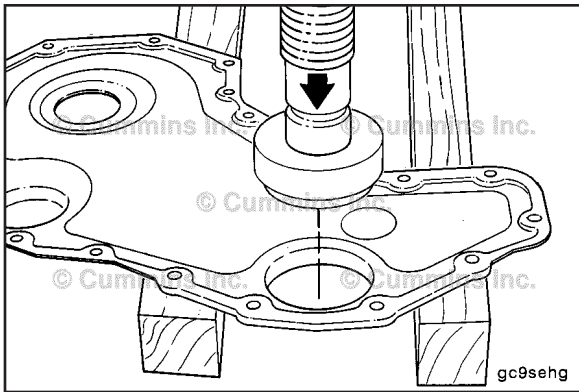

NOTE: Properly support the front gear cover lubricating oil seal flange to prevent damage to the lubricating oil seal and front gear cover.

Press the front crankshaft seal into the front gear cover from the backside of the front gear cover toward the front side.

Press the lubricating oil seal until the oil seal installation tool, Part Number 3824498, bottoms against the front cover.

NOTE: Each front crankshaft seal kit comes with an installation tool. This tool can be used in place of front crankshaft seal installation tool, Part Number 3824498, if **not** available. Using a mallet, tap around the installation tool to drive the front crankshaft seal into the front gear cover until the installation tool bottoms against the front gear cover.

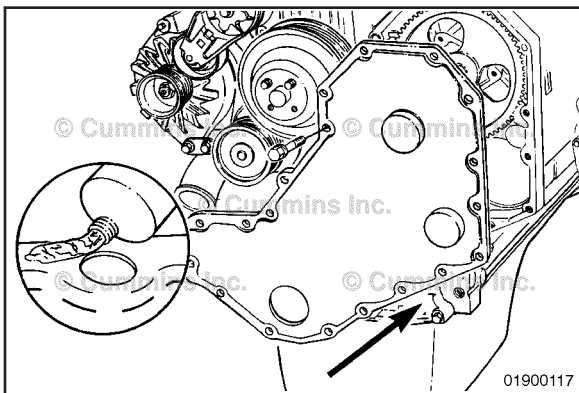

⚠ CAUTION ⚠

The seal lip and the sealing surface on the crankshaft must be free from all oil residue to prevent seal leaks.

Apply a thin bead of sealant, Part Number 3164070, to the sealing surface of the front cover.

NOTE: Do **not** remove the plastic seal pilot tool from the front crankshaft seal at this time. Use the plastic seal pilot tool to guide the seal on the crankshaft.

NOTE: Install the front cover within 10 minutes of applying the sealant, or the sealant will **not** seal correctly. Once installed, allow the sealant to dry for 30 minutes before operating the engine.

Install the front gear cover on the engine, using the plastic seal pilot tool to guide the front crankshaft seal onto the crankshaft.

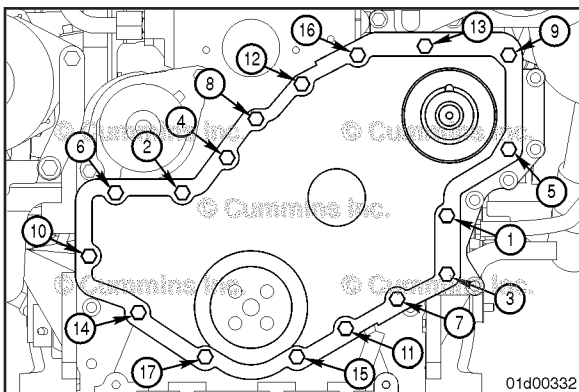

Install and tighten the front gear cover capscrews in the order indicated.

Torque Value: 24 N•m [212 in-lb]



Remove the plastic pilot tool from the crankshaft.

If previously equipped, or if the engine operates in a dusty environment, install a dust seal.

A pilot tool is **not** necessary for the dust seal. Slide the dust seal over the nose of the crankshaft.

Use the installation tool that came with the new front crankshaft seal to install the dust seal into the front gear cover. Install the dust seal until it is even with the front gear cover.

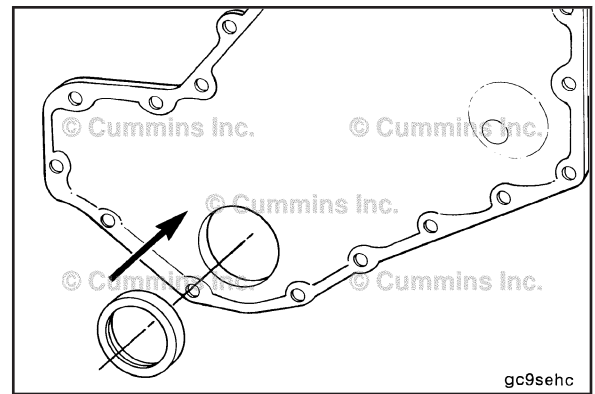

Finishing Steps

Rear Gear Train

If the oil pressure sensor/switch is located in the front gear cover, install and connect the sensor/switch. Use the following procedure in the ISB, ISB^{e4}, QSB4.5, QSB5.9, QSB6.7, ISC, QSC8.3, ISL, and QSL9 Engines Electronic Control System, Troubleshooting and Repair Manual, Bulletin 4021416. Refer to Procedure 019-066 in Section 19.

Install and connect the crankshaft position/speed sensor, if required. Use the following procedure in the ISB, ISB^{e4}, QSB4.5, QSB5.9, QSB6.7, ISC, QSC8.3, ISL, and QSL9 Engines Electronic Control System, Troubleshooting and Repair Manual, Bulletin 4021416. Refer to Procedure 019-365 in Section 19. Use the following procedure in the Electronic Control System ISB (4 cylinder) and ISB^e (4 and 6 cylinder) Series Engines Troubleshooting and Repair Manual, Bulletin 3666477. Refer to Procedure 019-042 in Section 19.

Install and connect the camshaft position sensor, if required. Use the following procedure in the ISB, ISB^{e4}, QSB4.5, QSB5.9, QSB6.7, ISC, QSC8.3, ISL, and QSL9 Engines Electronic Control System, Troubleshooting and Repair Manual, Bulletin 4021416. Refer to Procedure 019-363 in Section 19.

Install the front seal. Refer to Procedure 001-023 in Section 1.

If required, install the fan hub pulley. Refer to Procedure 008-039 in Section 8.

Install the vibration damper/crankshaft speed indicator ring. Use the following procedure if equipped with a viscous damper. Refer to Procedure 001-052 in Section 1. Use the following procedure if equipped with a rubber damper. Refer to Procedure 001-051 in Section 1. Use the following procedure if equipped with a crankshaft speed indicator ring **only**. Refer to Procedure 001-071 in Section 1.

For marine applications, install the engine water pump (cooling fan) drive belt. Refer to Procedure 008-002 in Section 8.

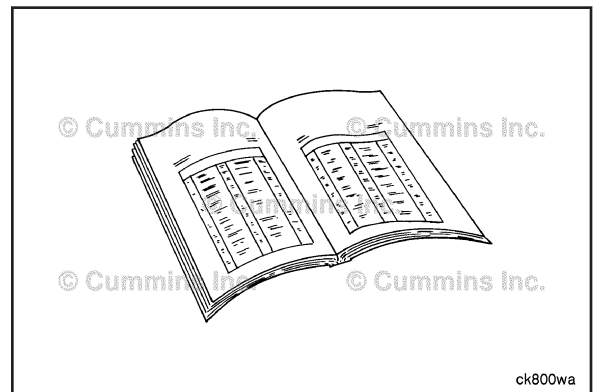

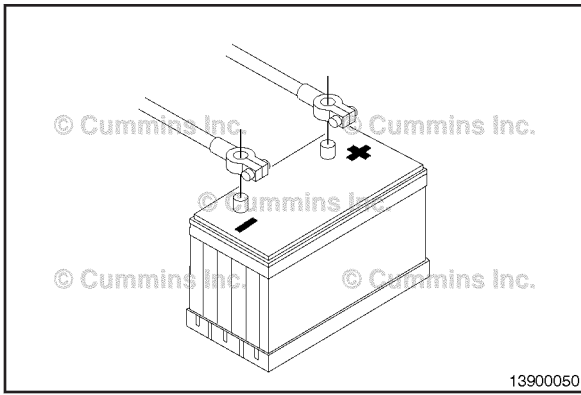

⚠ WARNING ⚠

Batteries can emit explosive gases. To reduce the possibility of personal injury, always ventilate the compartment before servicing the batteries. To reduce the possibility of arcing, remove the negative (-) battery cable first and attach the negative (-) battery cable last.

Connect the batteries.

Operate engine and check for leaks.

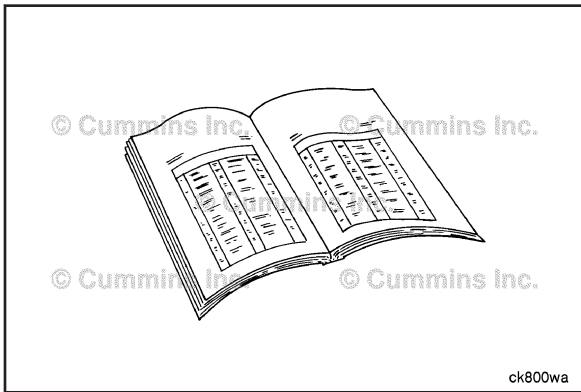

Front Gear Train

Install the vibration damper/crankshaft speed indicator ring. Use the following procedure if equipped with a viscous damper. Refer to Procedure 001-052 in Section 1.. Use the following procedure if equipped with a rubber damper. Refer to Procedure 001-051 in Section 1. Use the following procedure if equipped with a crankshaft speed indicator ring **only**. Refer to Procedure 001-071 in Section 1.

Install and connect the crankshaft position sensor. Use the following procedure in the ISB, ISB[®]4, QSB4.5, QSB5.9, QSB6.7, ISC, QSC8.3, ISL, and QSL9 Engines Electronic Control System, Troubleshooting and Repair Manual, Bulletin 4021416. Refer to Procedure 019-365 in Section 19.

If removed, install the fan hub. Refer to Procedure 008-039 in Section 8.

Install the engine water pump (cooling fan) drive belt. Refer to Procedure 008-002 in Section 8.

For marine applications, install the sea water pump drive belt. Refer to Procedure 008-126 in Section 8.

Install the belt guards, if required. Refer to Procedure 008-001 in Section 8.

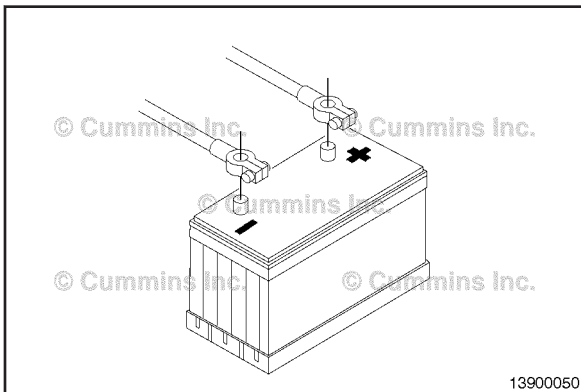

⚠ WARNING ⚠

Batteries can emit explosive gases. To reduce the possibility of personal injury, always ventilate the compartment before servicing the batteries. To reduce the possibility of arcing, remove the negative (-) battery cable first and attach the negative (-) battery cable last.

Connect the batteries.

Operate engine and check for leaks.

Gear Housing, Front (001-033)

Preparatory Steps

⚠️ WARNING ⚠️

Batteries can emit explosive gases. To reduce the possibility of personal injury, always ventilate the compartment before servicing the batteries. To reduce the possibility of arcing, remove the negative (-) battery cable first and attach the negative (-) battery cable last.

Disconnect the batteries.

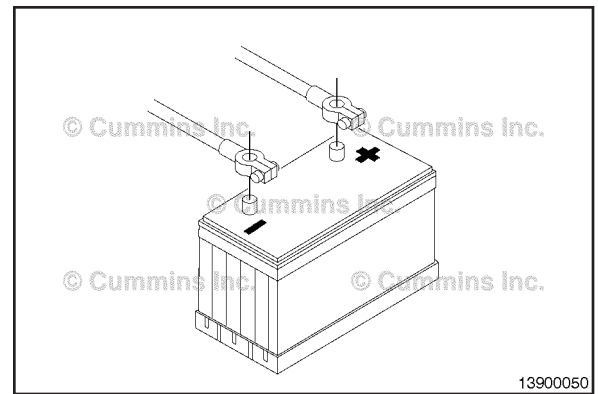

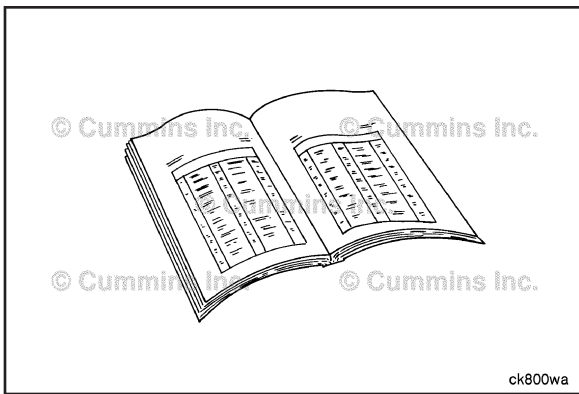

▲WARNING▲

Fuel is flammable. Keep all cigarettes, flames, pilot lights, arcing equipment, and switches out of the work area and areas sharing ventilation to reduce the possibility of severe personal injury or death when working on the fuel system.

NOTE: The minimum clearance required from the front gear housing face to any obstruction in the camshaft area for camshaft removal is 81.28 cm [32 in]. If the required amount of clearance is **not** available, the engine **must** be removed from the vehicle/vessel. Refer to Procedure 000-001 in Section 0.

Remove the belt guards, if equipped. Refer to Procedure 008-001 in Section 8.

Remove the sea water pump drive belt, if equipped. Refer to Procedure 008-126 in Section 8.

Remove the engine water pump (cooling fan) drive belt. Refer to Procedure 008-002 in Section 8.

If required, remove the fan hub. Refer to Procedure 008-039 in Section 8.

Remove the camshaft position sensor. Refer to Procedure 019-363 in Troubleshooting and Repair Manual, CM850 Electronic Control System, ISB, ISB^e4, QSB4.5, QSB6.7, ISC, QSC8.3, ISL, and QSL9 Engines, Bulletin 4021416.

Remove the vibration damper/crankshaft speed indicator ring. If equipped with a viscous damper, Refer to Procedure Procedure 001-052. If equipped with a rubber damper, Refer to Procedure Procedure 001-051. If equipped with a crankshaft speed indicator ring only, Refer to Procedure Procedure 001-071

Remove the front gear cover. Refer to Procedure 001-031

Remove the rocker lever cover. Refer to Procedure 003-011

Remove the rocker levers. Refer to Procedure 003-008

Remove the push tubes. Refer to Procedure 004-014

Use tappet replacement kit, Part Number 3822513, to raise the tappets. Refer to Procedure 004-015

Remove the camshaft. Refer to Procedure 001-008

Remove the fuel pump and gear. Refer to Procedure 005-016

Remove or disconnect driven accessories (i.e., hydraulic pump).

Remove

Remove the four front oil pan capscrews.

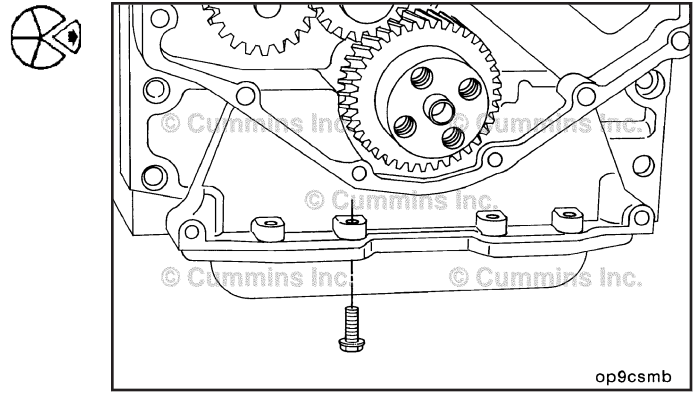

Remove the gear housing capscrews.

Note the location of the gear housing capscrews as they are removed. Some of the capscrews are an internal torx fastener and **must** be installed in the same location as removed to ensure proper clearance.

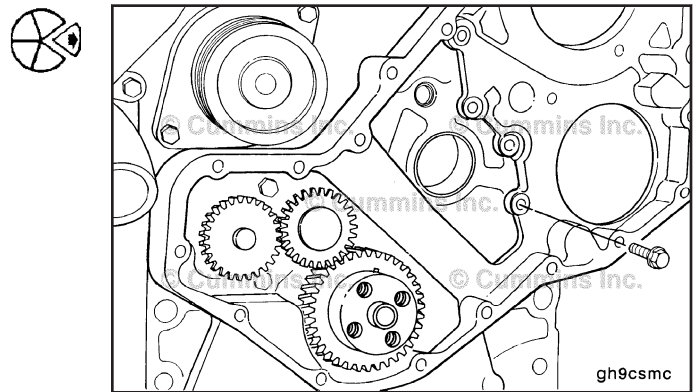

Using a feeler gauge, separate the lubricating oil pan gasket from the gear housing.

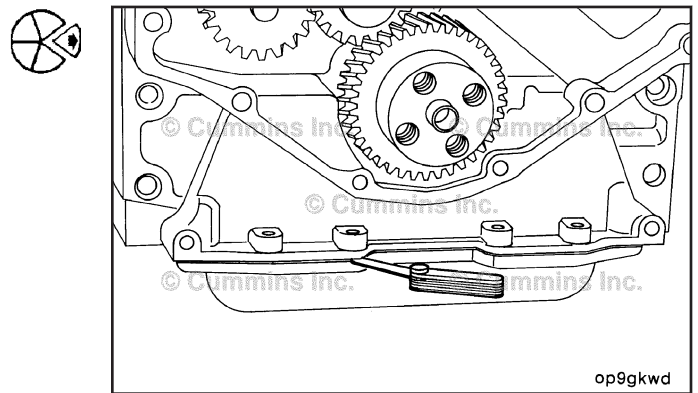

Use a plastic hammer to loosen the front gear housing.
Remove the gear housing.

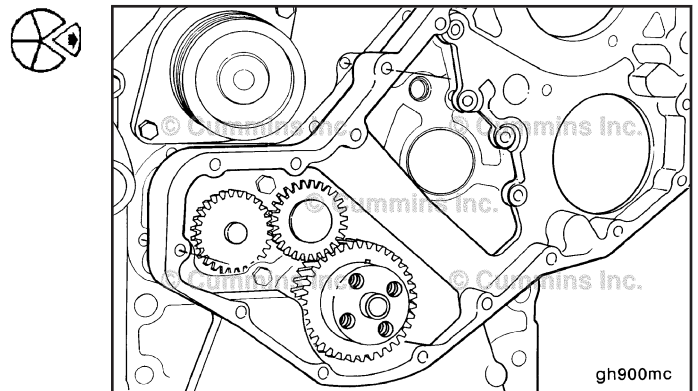

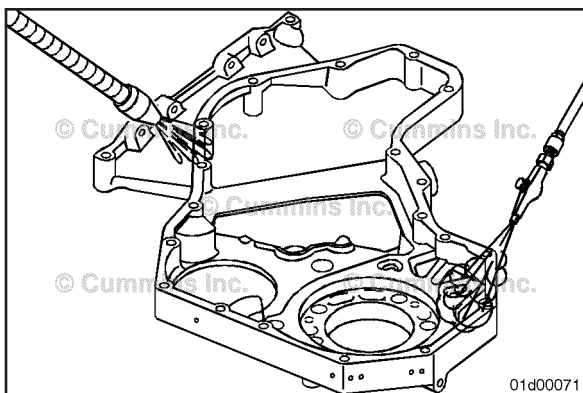

Clean and Inspect for Reuse

⚠ WARNING ⚠
When using solvents, acids, or alkaline materials for cleaning, follow the manufacturer's recommendations for use. Wear goggles and protective clothing to avoid personal injury.

⚠ WARNING ⚠
Compressed air used for cleaning should not exceed 207 kPa[30 psi]. Wear protective clothing and goggles to avoid personal injury.

Use solvent to clean the gear housing.

Dry the housing with compressed air.

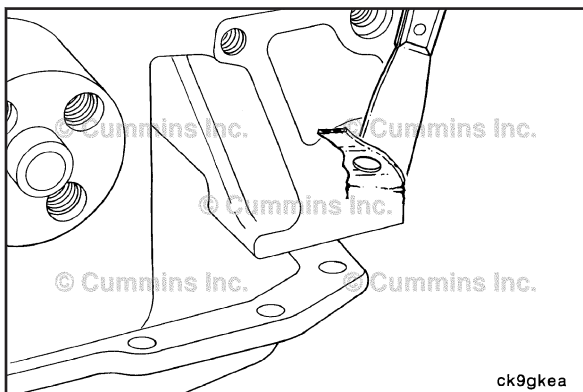

Clean all gasket material from the cylinder block.

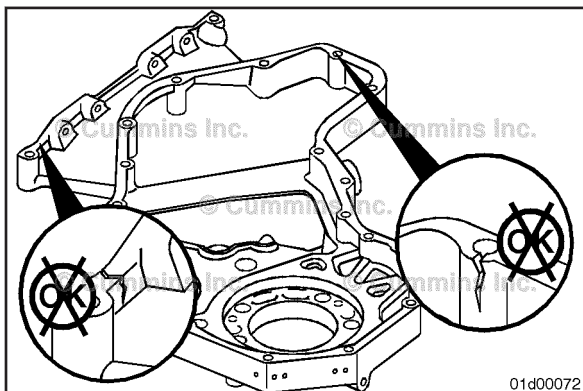

Inspect the gear housing for cracks or damage.
If any damage is found, replace the gear housing.

Install

For engines equipped with a paper gasket style oil pan, inspect the oil pan gasket for damage.

NOTE: If the engine is equipped with a suspended oil pan with a rubber oil pan gasket and the gasket is found to be damaged, the oil pan **must** be removed and the entire oil pan gasket replaced. Refer to Procedure Procedure 007-025. If the engine used sealant only between the gear housing and the oil pan, remove the old sealant and apply new sealant, Part Number 3164070, to the oil pan mounting flange.

If the pan gasket is torn, it can be repaired.

Cut the torn gasket off even with the front of the cylinder block.

Using the old gasket as a pattern, cut the front section of a new gasket to the same size.

NOTE: The gear housing must be installed within 10 minutes of applying the sealant.

Clean the sealing surfaces.

Coat the new gasket on both sides with sealant, Part Number 3164067.

Be sure there is a bead of sealant at the intersecting joint of the cylinder block, oil pan, and gear housing.

Use common thread or very fine wire to hold the new gasket splice in position as illustrated.

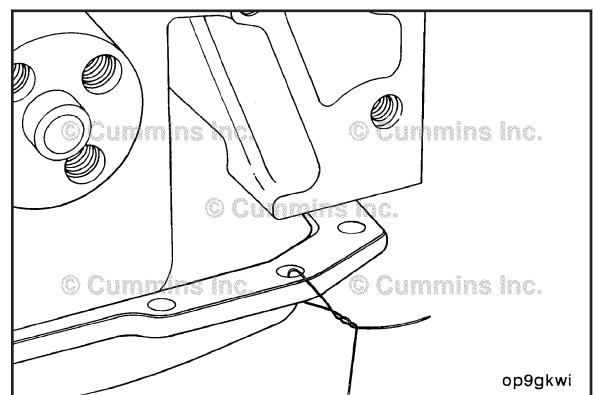
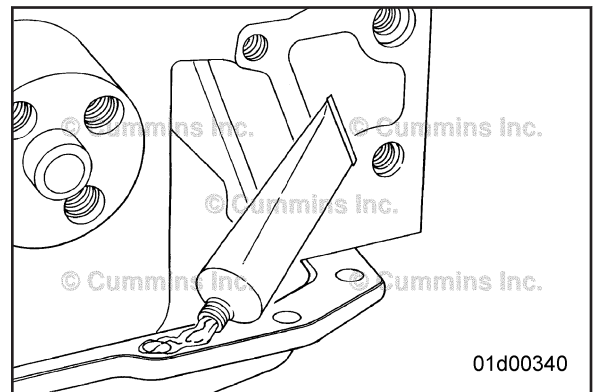
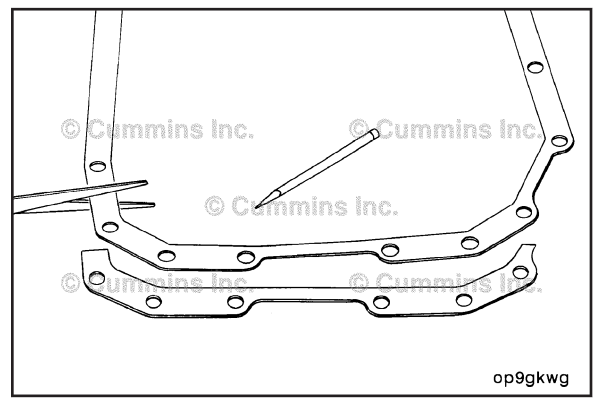
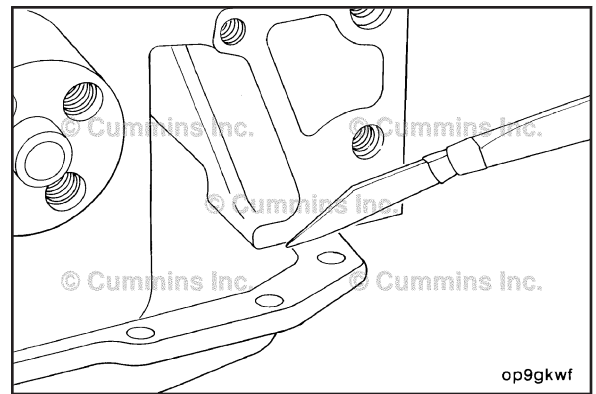

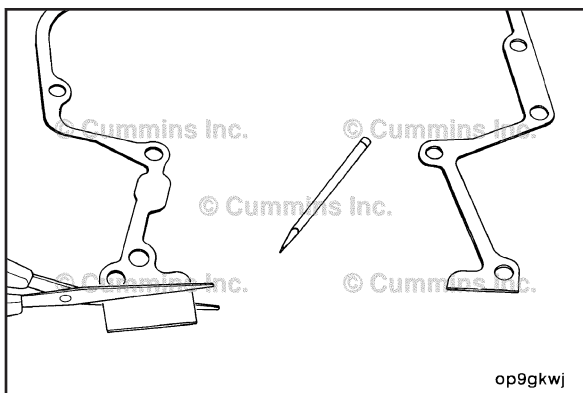

Check the fit of the new gear housing to cylinder block gasket. It may be necessary to trim the bottom edges of the gasket before installation.

NOTE: When properly trimmed, the gear housing gasket **must** be even with the lubricating oil pan gasket when installed.

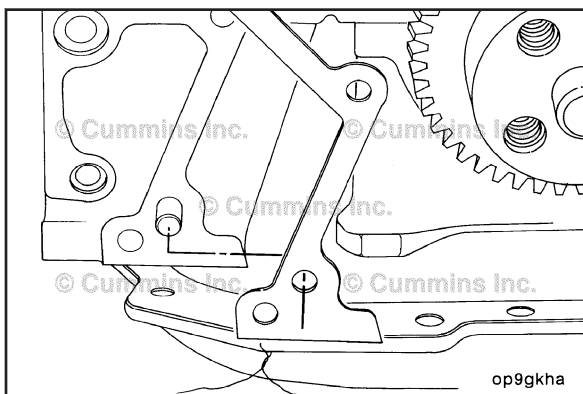

Position the gasket on the alignment dowels.

Use guide pins, M8 x 1.25 x 50, to assist in aligning the gasket and gear housing. Make sure to remove the guide pins after alignment.

Apply a bead of sealant, Part Number 3164067, at the intersecting joint of the cylinder block, oil pan, and gear housing.

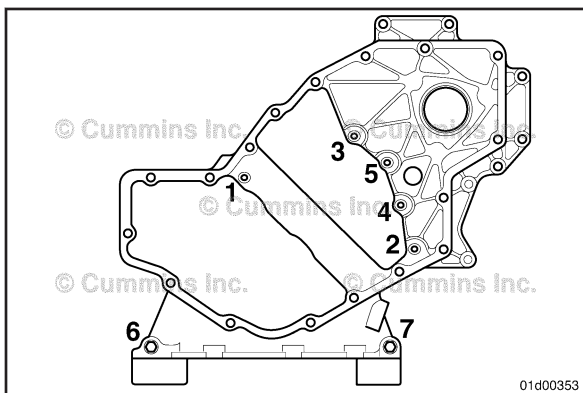

Carefully install the gear housing.

Make sure the gasket is still in place.



NOTE: Locations numbered 1, 2, 3, 4, and 5 in the illustration use internal torx fasteners. Make sure to install the correct fasteners in the correct location.

Install and tighten the mounting capscrews in the defined order.

Torque Value: 24 N•m [18 ft-lb]

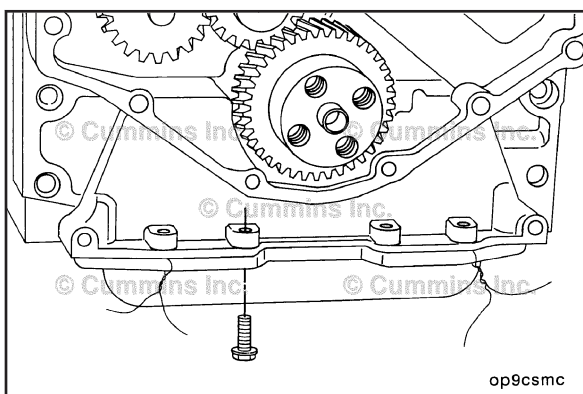

Start the oil pan capscrews into the holes **not** being used to tie the gasket in place.

Remove the thread or wire holding the gasket in place.

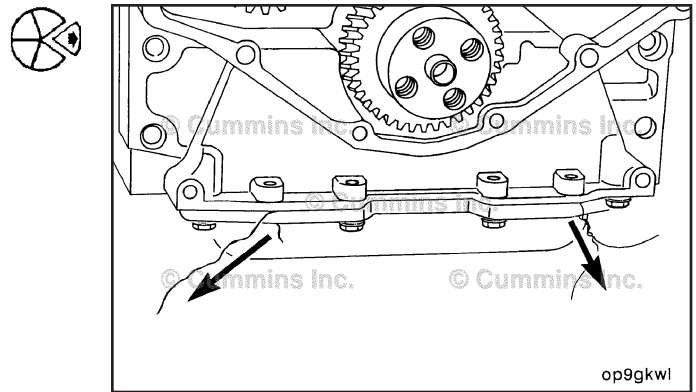

Install the remaining two capscrews.

Tighten the capscrews.

Torque Value: 24 N•m [18 ft-lb]

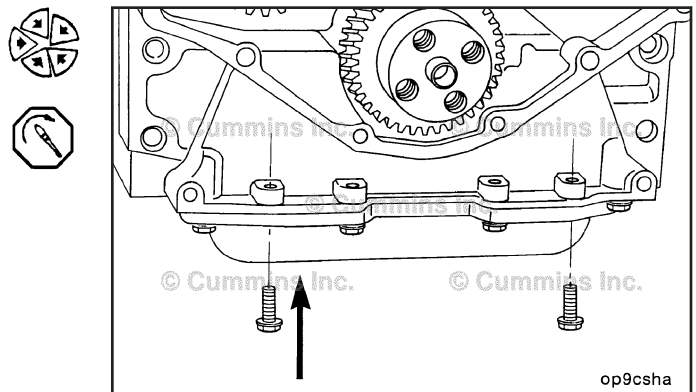

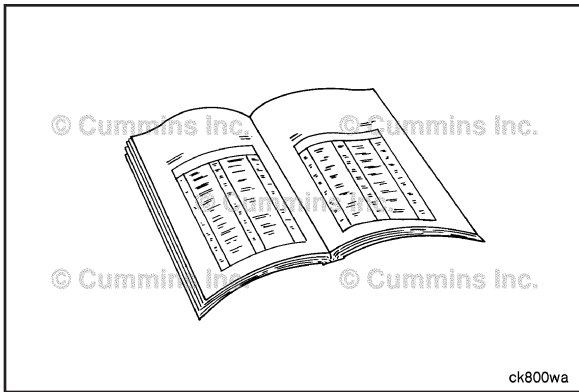

Finishing Steps

Install the camshaft. Refer to Procedure 001-008

Release the tappets. Refer to Procedure 004-015

Install the push rods. Refer to Procedure 004-014

Install the rocker levers. Refer to Procedure 003-008

Adjust the valve lash. Refer to Procedure 003-004

Install the rocker lever cover. Refer to Procedure 003-011

Install the fuel pump and gear. Refer to Procedure 005-016

Install or connect driven accessories (i.e., hydraulic pump).

Install the front gear cover. Refer to Procedure 001-031

Install the vibration damper/crankshaft speed indicator ring. If equipped with a viscous damper, Refer to Procedure 001-052. If equipped with a rubber damper, Refer to Procedure 001-051. If equipped with a crankshaft speed indicator ring only, Refer to Procedure 001-071

Install the camshaft position sensor. Refer to Procedure 019-363 in Troubleshooting and Repair Manual, CM850 Electronic Control System, ISB, ISB^e4, QSB4.5, QSB6.7, ISC, QSC8.3, ISL, and QSL9 Engines, Bulletin 4021416.

If removed, install the fan hub. Refer to Procedure 008-039

Install the engine water pump drive belt. Refer to Procedure 008-002

If equipped, install the sea water pump drive belt. Refer to Procedure 008-126

If equipped, install the belt guards. Refer to Procedure 008-001

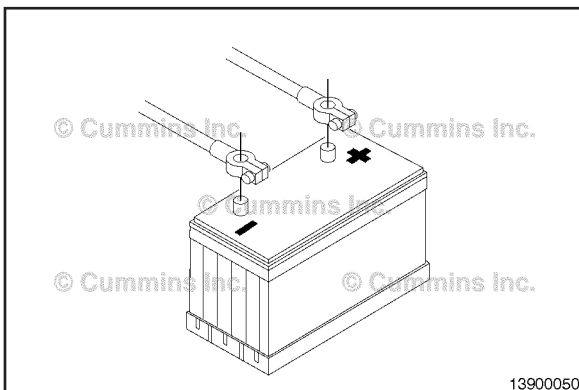

WARNING

Batteries can emit explosive gases. To reduce the possibility of personal injury, always ventilate the compartment before servicing the batteries. To reduce the possibility of arcing, remove the negative (-) battery cable first and attach the negative (-) battery cable last.

Connect the batteries.

Operate the engine at idle for 5 to 10 minutes and check for leaks or loose parts.

Gear Housing, Rear (001-034)

Preparatory Steps

⚠ WARNING ⚠

Batteries can emit explosive gases. To reduce the possibility of personal injury, always ventilate the compartment before servicing the batteries. To reduce the possibility of arcing, remove the negative (-) battery cable first and attach the negative (-) battery cable last.

⚠ WARNING ⚠

This component or assembly weighs greater than 23 kg [50 lb]. To prevent serious personal injury, be sure to have assistance or use appropriate lifting equipment to lift this component or assembly.

⚠ WARNING ⚠

Support the rear of the engine using the rear support attached to the rear of the cylinder block. Failure to support the engine can cause personal injury.

- Disconnect the batteries. Refer to Procedure 013-009 (Battery Cables and Connections) in Section 13.
- Remove the transmission. Refer to the original equipment manufacturer's instructions.
- Remove the flywheel. Refer to Procedure 016-005 (Flywheel) in Section 16.
- Remove the flexplate. Refer to Procedure 016-004 (Flexplate) in Section 16.
- Remove the crankcase breather tube. Refer to Procedure 003-018 (Crankcase Breather Tube) in Section 3.
- Remove the rear crankshaft seal. Refer to Procedure 001-024 (Crankshaft Seal, Rear) in Section 1.
- Remove the flywheel housing. Refer to Procedure 016-006 (Flywheel Housing) in Section 16.
- Remove the fuel pump. Refer to Procedure 005-016 (Fuel Pump) in Section 5.
- If equipped, remove the hydraulic pump unit. Refer to Procedure 009-016 (Hydraulic Pump Drive) in Section 9.
- If equipped, remove the air compressor. Refer to Procedure 012-014 (Air Compressor) in Section 12.
- Remove the camshaft gear. Refer to Procedure 001-012 (Camshaft Gear (Camshaft Installed)) in Section 1.

Service Tip: Engines equipped with air compressors may require that the air compressor be timed to the engine. To make sure that the air compressor is properly timed when the camshaft gear is later installed, scribe an alignment line on the air compressor and camshaft gear before removing the camshaft gear or air compressor.

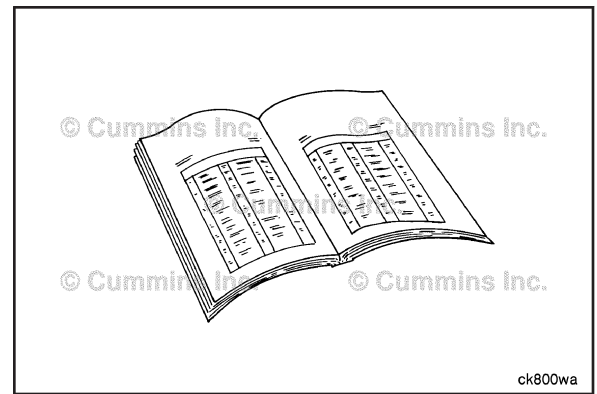

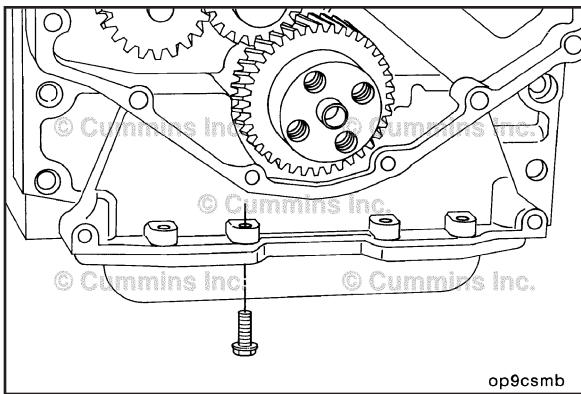

Remove

Remove the four (4) oil pan to rear gear housing cap screws.

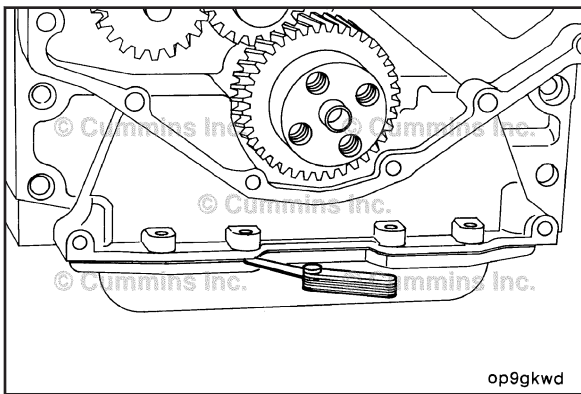

Use a feeler gauge to separate the lubricating oil pan gasket from the gear housing.

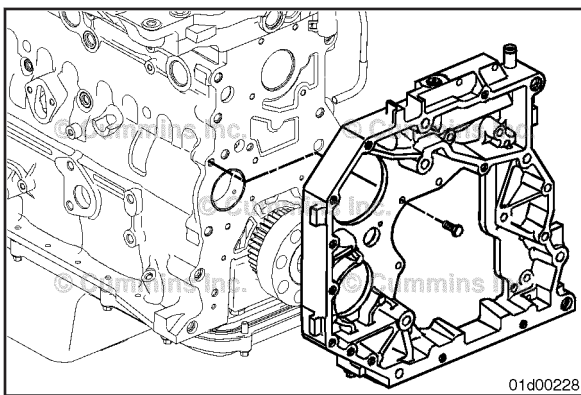

Remove the rear gear housing cap screws and housing.

Clean and Inspect for Reuse

⚠ WARNING ⚠

When using solvents, acids, or alkaline materials for cleaning, follow the manufacturer's recommendations for use. Wear goggles and protective clothing to reduce the possibility of personal injury.

⚠ WARNING ⚠

Wear appropriate eye and face protection when using compressed air. Flying debris and dirt can cause personal injury.

Clean the rear gear housing with solvent. Dry with compressed air.

Clean the oil supply hole for the accessory drive.

NOTE: The rear gear housing has oil drain and supply passages designed into the housing. Make sure these passages are clean and free of debris.

Inspect the rear gear housing for signs of leakage or any other damage.

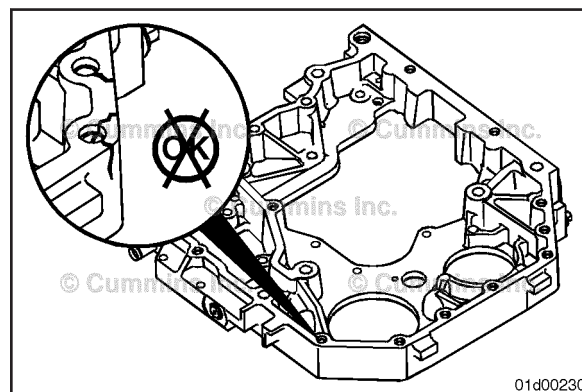
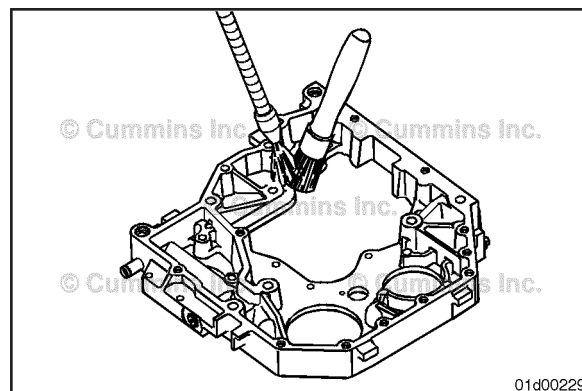

Install

For engines equipped with a paper gasket style oil pan, inspect the oil pan gasket for damage.

NOTE: If the engine is equipped with a suspended oil pan with a rubber oil pan gasket and the gasket is found to be damaged, the oil pan **must** be removed and the entire oil pan gasket replaced. Refer to Procedure 007-025 (Lubricating Oil Pan) in Section 7. If the engine used sealant only between the gear housing and the oil pan, remove the old sealant and apply new sealant, part number 3164070, to the oil pan mounting flange.

If the pan gasket is torn, it can be repaired.

Cut the torn gasket off even with the front of the cylinder block.

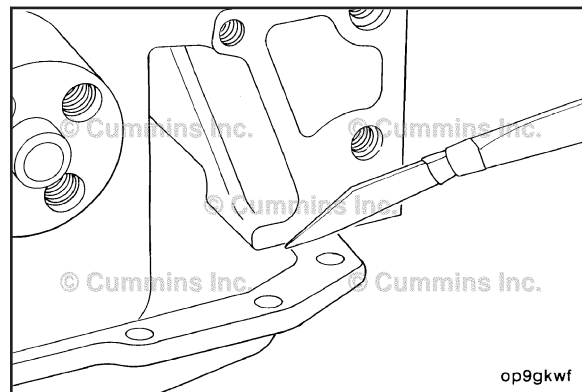

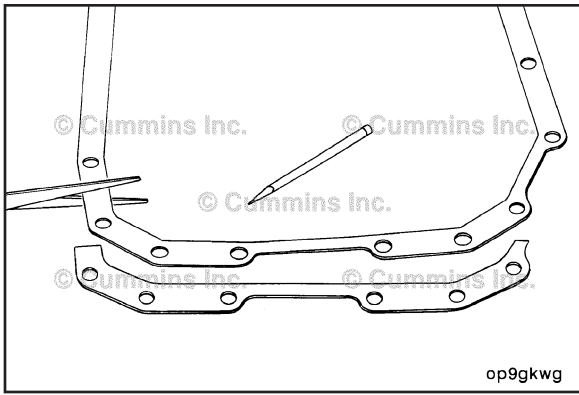

Using the old gasket as a pattern, cut the front section of a new gasket to the same size.

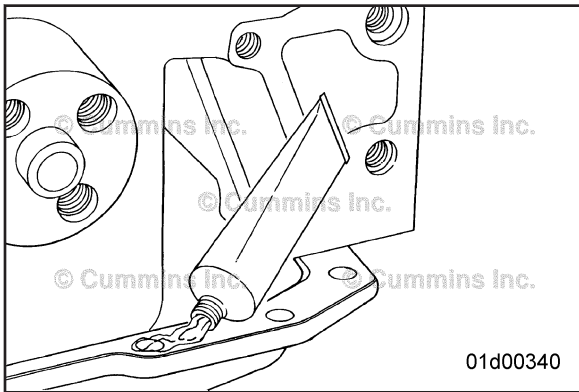

NOTE: The gear housing **must** be installed within 10 minutes of applying the sealant.

Clean the sealing surfaces.



Coat the new gasket on both sides with sealant, Part Number, 3164067.



Be sure there is a bead of sealant at the intersecting joint of the cylinder block, oil pan, and gear housing.

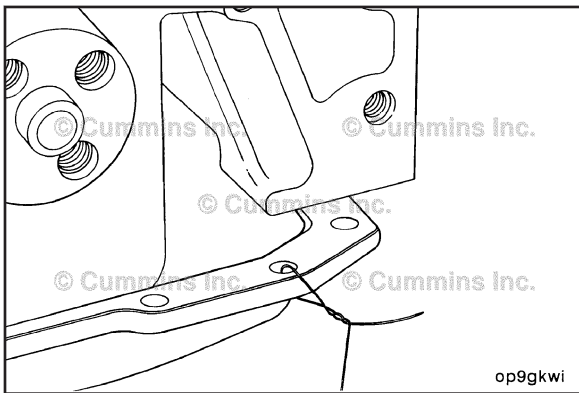

Use common thread or a very fine wire to hold the new gasket splice in position as illustrated.

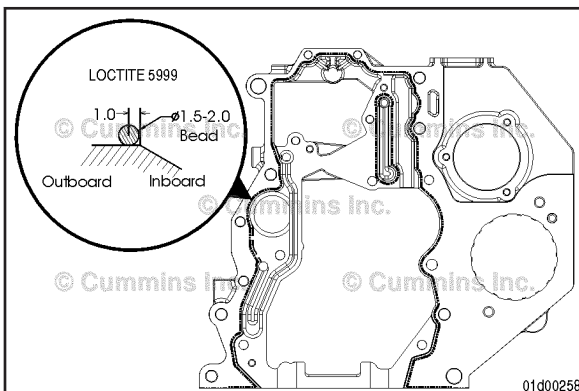

CAUTION

Make sure to only apply sealant to the areas specified. Failure to do so may block oil passages to the accessory drive and/or cause a loss of oil pressure. This will result in severe engine damage.



Apply a 1.5 to 2.0 mm [0.06 to 0.08 in] wide bead of sealant, Part Number 3164070, to the block side of the gear housing in the path illustrated and install the rear gear housing capscrews and housing.

Be sure there is a bead of sealant at the intersection joint of the cylinder block, oil pan, and gear housing.

NOTE: Install the gear housing within 10 minutes of applying sealant or the sealant will **not** seal correctly. Once installed, allow the sealant to dry for 30 minutes before running the engine.

Tighten the capscrews as shown.

Torque Value:

M12
 Step 1 50 N•m [37 ft-lb]

Torque Value:

M10
 Step 1 47 N•m [35 ft-lb]

Torque Value:

M8
 Step 1 24 N•m [212 in-lb]

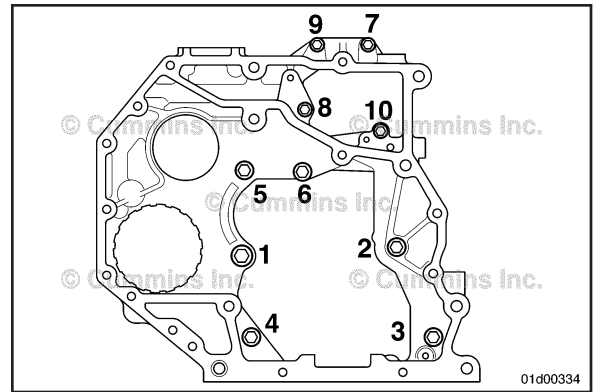

Start the oil pan capscrews in the holes **not** being used to tie the gasket in place.

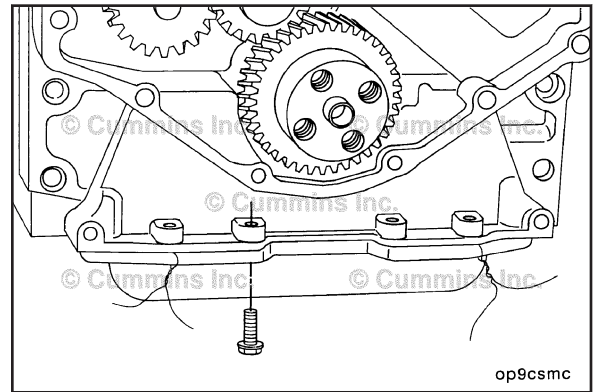

Remove the thread or wire holding the gasket in place.

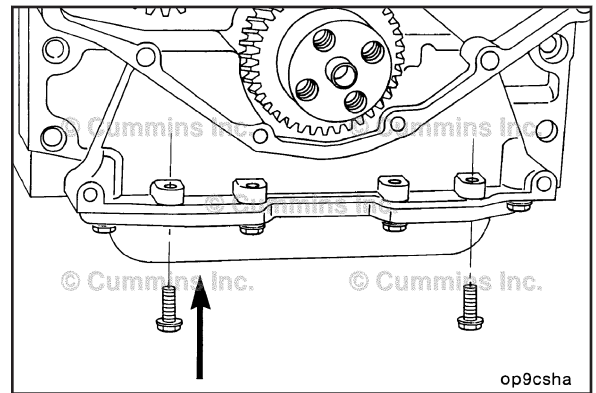

Install the remaining two (2) oil pan capscrews and tighten.

Torque Value: 28 N•m [248 in-lb]

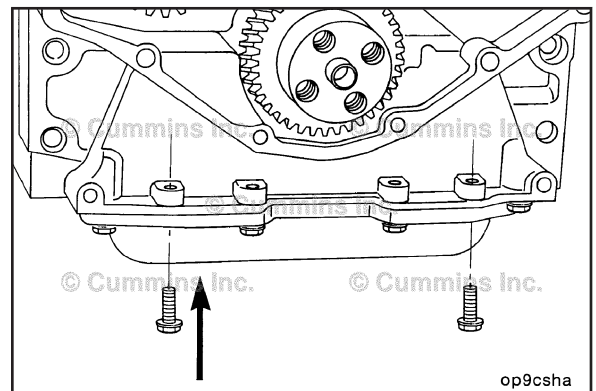

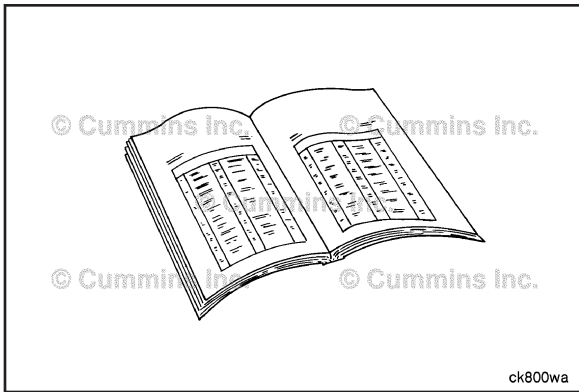

Finishing Steps

⚠ WARNING ⚠

Support the rear of the engine using the rear support attached to the rear of the cylinder block. Failure to support the engine can cause personal injury.

⚠ WARNING ⚠

This component or assembly weighs greater than 23 kg [50 lb]. To prevent serious personal injury, be sure to have assistance or use appropriate lifting equipment to lift this component or assembly.

⚠ WARNING ⚠

Batteries can emit explosive gases. To reduce the possibility of personal injury, always ventilate the compartment before servicing the batteries. To reduce the possibility of arcing, remove the negative (-) battery cable first and attach the negative (-) battery cable last.

Service Tip: Engines equipped with air compressors may require that the air compressor be timed to the engine. To make sure that the air compressor is properly timed when the camshaft gear is installed, a line should have been scribed during when removed. Align this line when installing the air compressor. If the line was **not** scribed or is no longer available. Refer to Procedure 012-014 in Section 1.

- Install the camshaft gear. Refer to Procedure 001-012 (Camshaft Gear (Camshaft Installed)) in Section 1.
- If equipped, install the air compressor. Refer to Procedure 012-014 (Air Compressor) in Section 12.
- If equipped, install the hydraulic pump unit. Refer to Procedure 009-016 (Hydraulic Pump Drive) in Section 9.
- Install the fuel pump. Refer to Procedure 005-016 (Fuel Pump) in Section 5.
- Install the flywheel housing. Refer to Procedure 016-006 (Flywheel Housing) in Section 16.
- Install the rear crankshaft seal. Refer to Procedure 001-024 (Crankshaft Seal, Rear) in Section 1.
- Install the flywheel. Refer to Procedure 016-005 (Flywheel) in Section 16.
- Install the flexplate. Refer to Procedure 016-004 (Flexplate) in Section 16.
- Install the crankcase breather tube. Refer to Procedure 003-018 (Crankcase Breather Tube) in Section 3.
- Install the transmission. Refer to the original equipment manufacturer's instructions.
- Connect the batteries. Refer to Procedure 013-009 (Battery Cables and Connections) in Section 13.
- Operate the engine and check for leaks.

Piston (001-043)

Clean and Inspect for Reuse

⚠CAUTION⚠

Do not use the bead-blast method to clean the pistons. The pistons will be damaged by blast material embedded in the aluminum.

⚠CAUTION⚠

Do not clean the pistons in an acid tank. Damage to the piston can occur.

NOTE: Soaking the pistons overnight will usually loosen the carbon deposits.

Soak the pistons in cold parts cleaner.

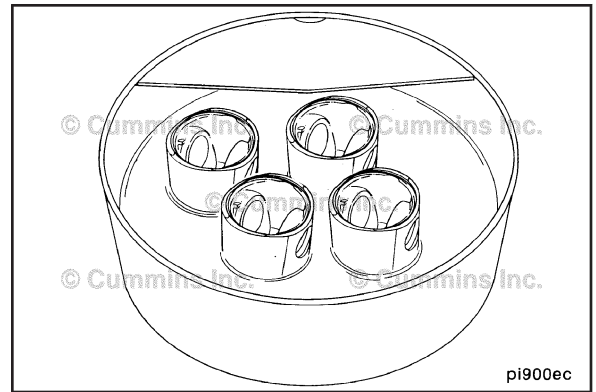

⚠CAUTION⚠

Do not use a metal brush. A metal brush will damage the piston ring grooves.

Wash the pistons in a strong solution of laundry detergent and hot water.

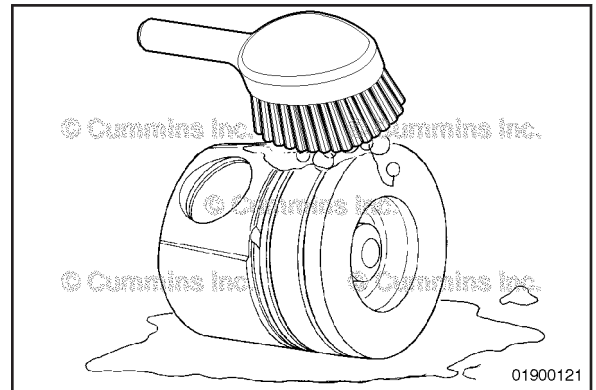

⚠CAUTION⚠

Do not use a ring groove cleaner and make sure not to scratch the ring sealing surface in the piston groove.

Clean the remaining deposits from the ring grooves with the square end of a broken ring.

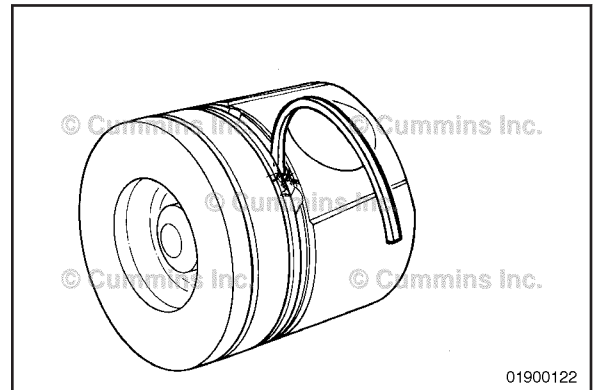

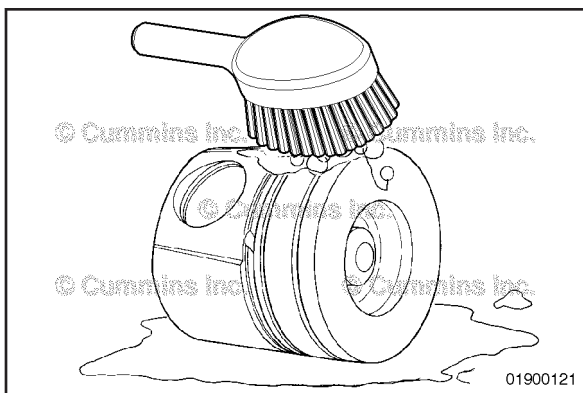

⚠ WARNING ⚠

When using solvents, acids, or alkaline materials for cleaning, follow the manufacturer's recommendations for use. Wear goggles and protective clothing to reduce the possibility of personal injury.

⚠ WARNING ⚠

Wear appropriate eye and face protection when using compressed air. Flying debris and dirt can cause personal injury.

⚠ CAUTION ⚠

Do not clean the pistons and connecting rods in an acid tank. Damage to the pistons and connecting rods can occur.

Wash the pistons again in a detergent solution or solvent.

Rinse the pistons in clean, hot water.

Dry the pistons with compressed air.

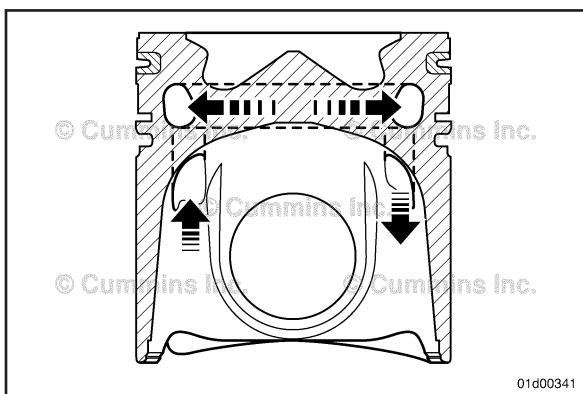

Some pistons have an oil passage cast into the top of the piston for cooling purposes. When cleaning the pistons, make sure the oil passage is clean and free of debris.

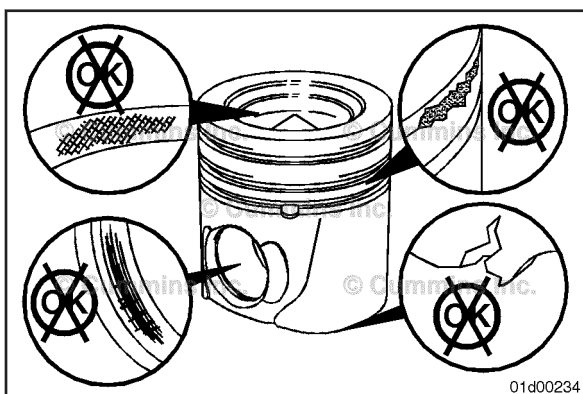

Failure Analysis Inspection

Inspect the piston for damage and wear to the skirt, pin bore, top, and ring lands.

Inspect the piston pin for damage and wear.

For Engines Displacing 3.9 liters and 5.9 liters

NOTE: For accuracy, the following measurements are to be completed with the components at room temperature, 20°C [68°F]

Measure the piston skirt diameter 12 mm [0.5 in] from the bottom of the piston.

3.9L and 5.9L Standard Piston Skirt Diameter

mm		in
101.864	MIN	4.0104
101.887	MAX	4.0113

3.9L and 5.9L Oversize Piston Skirt Diameter

	mm		in
Oversize			
0.5 mm	102.364	MIN	4.0301
	102.387	MAX	4.0310
1.0 mm	102.864	MIN	4.0498
	102.887	MAX	4.0507

For Engines Displacing 4.5 liters and 6.7 liters

NOTE: For accuracy, the following measurements are to be completed with the components at room temperature, 20°C [68°F]

Measure the piston skirt diameter 21.3 mm [0.84 in] (A) from the bottom of the piston.

4.5L and 6.7L Standard Piston Skirt Diameter

mm		in
106.878	MIN	4.2078
106.892	MAX	4.2083

4.5L and 6.7L Oversize Piston Skirt Diameter

	mm		in
Oversize			
0.5 mm	107.378	MIN	4.2275
	107.392	MAX	4.2280

Measure the piston ring clearance. Use a new piston ring to measure the clearance in the ring groove.

Piston Ring Clearance

	mm		in
Intermediate	0.040	MIN	0.0016
	0.110	MAX	0.0043
Oil control	0.040	MIN	0.0016
	0.085	MAX	0.0033

NOTE: The top piston ring clearance is **not** measured due to the type of piston ring used. The clearance can **not** be measured accurately with a typical feeler gauge

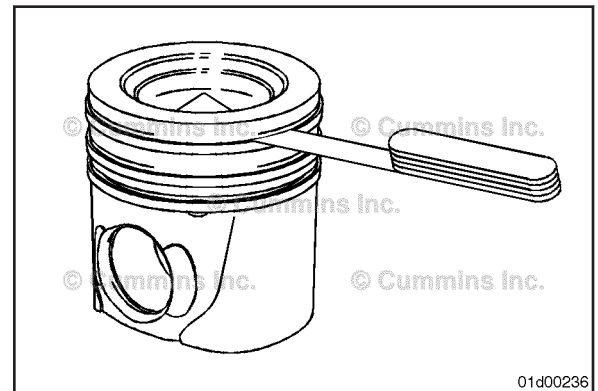
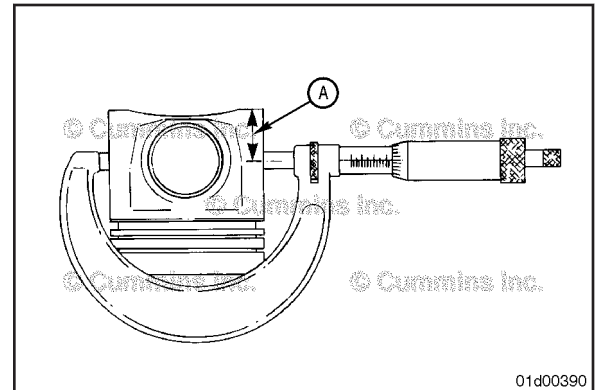
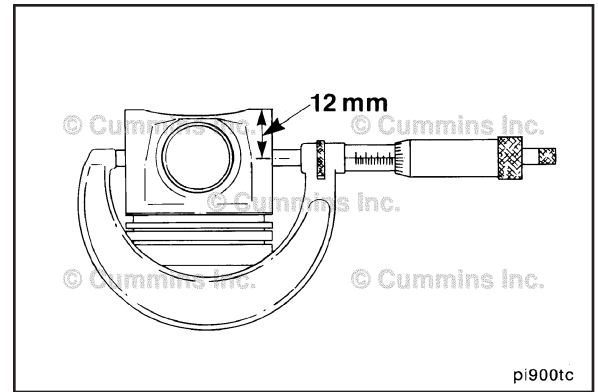

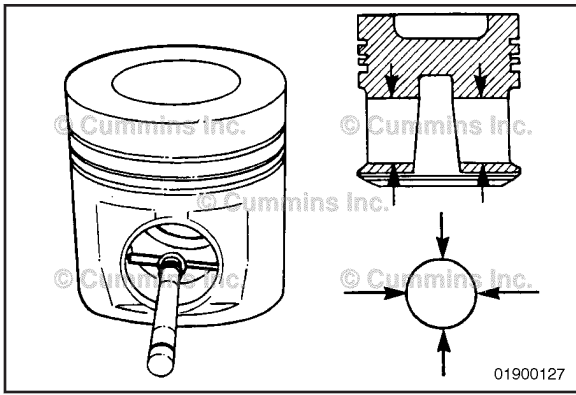

Measure the piston pin bore.

Piston Pin Bore

mm		in
40.006	MIN	1.5750
40.012	MAX	1.5753

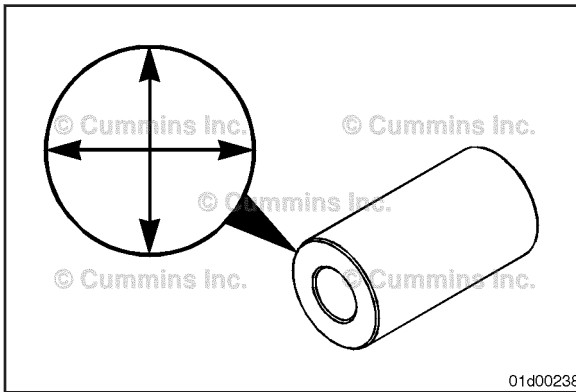

Measure the piston pin diameter.

Piston Pin Diameter

mm		in
39.997	MIN	1.5747
40.003	MAX	1.5749

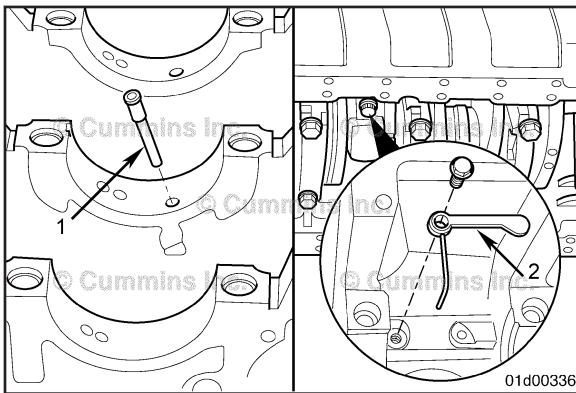

Piston Cooling Nozzle (001-046)

General Information

Depending on engine rating and application, the engine may be equipped with one of two types of piston cooling nozzle configurations:

- 1 Saddle Jet Piston Cooling Nozzle
- 2 J-jet Piston Cooling Nozzle

Saddle jet piston cooling nozzles are typically used in lower power applications and are located in the main bearing saddle on the block side. Oil is supplied from the main bearing. Cylinder blocks using saddle jet piston cooling nozzles may be machined for J-jet piston cooling nozzles as well. If this is the case, capscrews are required to be installed in the J-jet piston cooling nozzle location.

J-jet piston cooling nozzles are located in between the main bearing saddles on the exhaust side of the engine. Oil is supplied from an oil gallery in the block on the exhaust side of the engine. Cylinder blocks using J-jet piston cooling nozzles may be machined for saddle jet piston cooling nozzles as well. If this is the case, plugs are required to be installed in the saddle jet piston cooling nozzle location.

NOTE: 4.5 L and 6.7 L engine are only equipped with J-jet piston cooling nozzles. The cylinder blocks for these engines are **not** machined for saddle jet piston cooling nozzles. No saddle jet plugs are necessary.

Preparatory Steps

⚠ WARNING ⚠

Batteries can emit explosive gases. To reduce the possibility of personal injury, always ventilate the compartment before servicing the batteries. To reduce the possibility of arcing, remove the negative (-) battery cable first and attach the negative (-) battery cable last.

Disconnect the batteries.

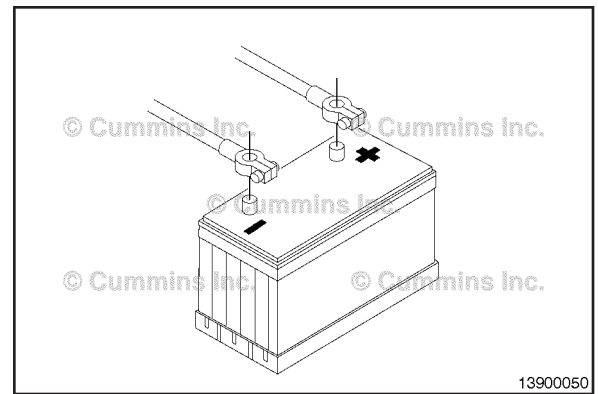

⚠ WARNING ⚠

To reduce the possibility of personal injury, avoid direct contact of hot oil with your skin.

⚠ WARNING ⚠

Some state and federal agencies have determined that used engine oil can be carcinogenic and cause reproductive toxicity. Avoid inhalation of vapors, ingestion, and prolonged contact with used engine oil. If not reused, dispose of in accordance with local environmental regulations.

Drain the lubricating oil. Refer to Procedure Procedure 007-037

Remove the oil pan. Refer to Procedure Procedure 007-025

Remove the lubricating oil suction tube. Refer to Procedure Procedure 007-035

Remove the block stiffener plate. Refer to Procedure Procedure 001-089

⚠ WARNING ⚠

This assembly weighs 23 kg [50 lb] or more. To reduce the possibility of personal injury, use a hoist or get assistance to lift this assembly.

NOTE: It is **not** necessary to remove the crankshaft if removing J-jet piston cooling nozzles.

Remove the crankshaft. Refer to Procedure Procedure 001-016

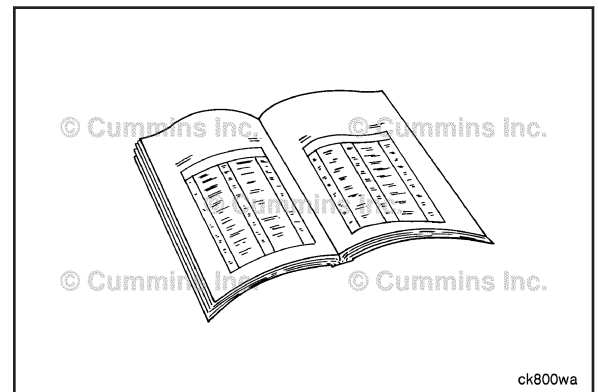

Remove

Remove the piston cooling nozzles or plugs by pressing from the top with an appropriate size punch.

NOTE: Do **not** reuse the saddle jet piston cooling nozzles or plugs once removed.

NOTE: Blocks using saddle jet piston cooling nozzles may be machined for J-jet piston cooling nozzles as well. If this is the case, capscrews will be installed in the J-jet piston cooling nozzle location. If it is necessary to remove these capscrews, follow the J-jet piston cooling nozzle removal procedure below.

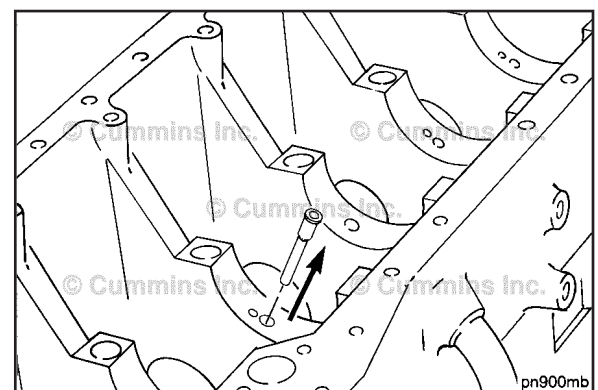

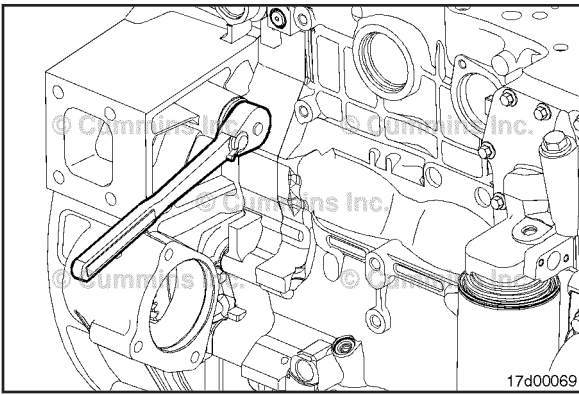

Rotate the crankshaft to various positions to access each piston cooling nozzle and/or capscrew.

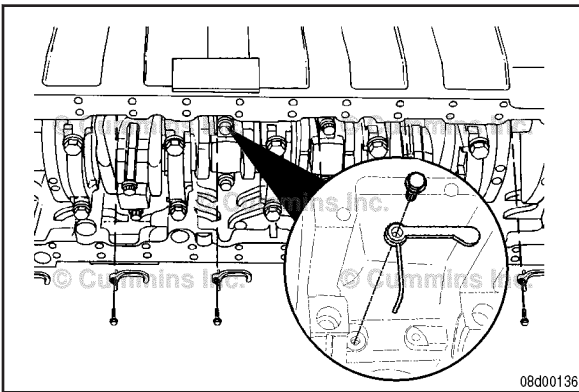

Remove the piston cooling nozzles and/or capscrews.

NOTE: Blocks using J-jet piston cooling nozzles may be machined for saddle jet piston cooling nozzles as well. If this is the case, plugs will be installed in the saddle jet piston cooling nozzle locations. If it is necessary to remove these plugs, please follow the saddle jet piston cooling nozzle removal procedures outlined earlier in this procedure.

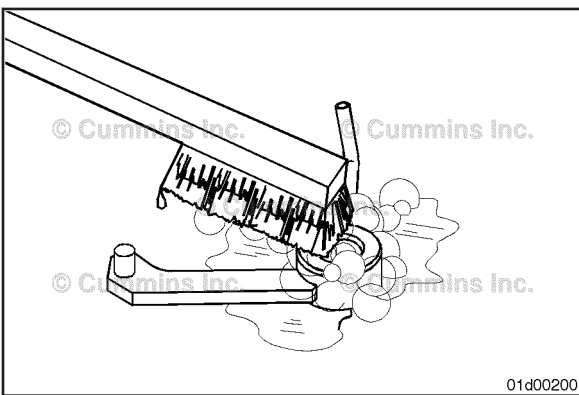

Clean and Inspect for Reuse



⚠ WARNING ⚠

When using solvents, acids, or alkaline materials for cleaning, follow the manufacturer's recommendations for use. Wear goggles and protective clothing to reduce the possibility of personal injury.

⚠ WARNING ⚠

Wear appropriate eye and face protection when using compressed air. Flying debris and dirt can cause personal injury.

NOTE: Do not reuse the saddle jet piston cooling nozzles or plugs once removed.

Clean the J-jet piston cooling nozzle and oil passage in the block using solvent. Dry with compressed air.

Inspect the capscrew and J-jet piston cooling nozzle for damage.

Install

⚠CAUTION⚠

Do not use a hammer to install the piston cooling nozzles. Use hand pressure only. Using a hammer can cause component damage.

Push the piston cooling nozzle or plug into place by hand.

Use a flat punch to push the nozzle or plug into the recess.

NOTE: Blocks using saddle jet piston cooling nozzles may be machined for J-jet piston cooling nozzles as well. If this is the case, capscrews will be installed in the J-jet piston cooling nozzle location. If previously removed, follow the J-jet piston cooling nozzle installation procedure later in this procedure.

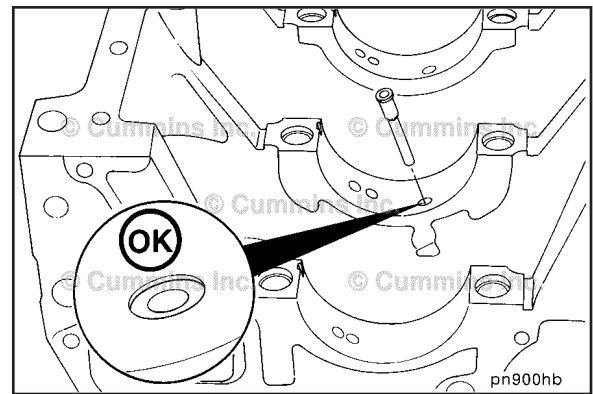

⚠CAUTION⚠

Slight bending of the piston cooling nozzles can result in severe engine damage. Replace piston cooling nozzle if it is bent or damaged during disassembly or assembly.

Install the piston cooling nozzle and/or capscrew one cylinder at a time rotating the crankshaft as necessary for access.

Use a long extension to guide the capscrew and/or piston cooling nozzle into place.

NOTE: The locator pin on the J-jet piston cooling nozzle **must** engage the locating hole in the block for proper alignment.

Tighten the capscrew.

Torque Value:

J-Jet Capscrew

Step 1 15 N•m [133 in-lb]

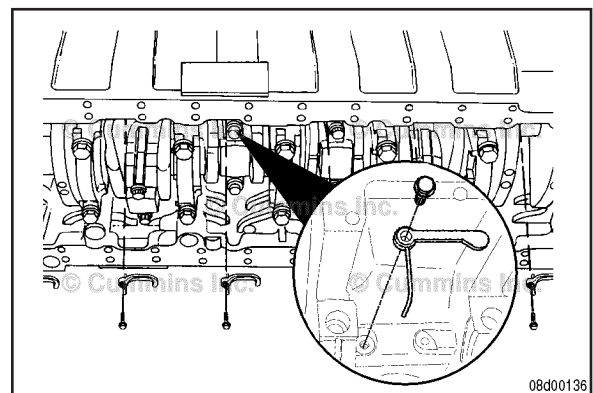

Finishing Steps

⚠WARNING⚠

This assembly weighs 23 kg [50 lb] or more. To reduce the possibility of personal injury, use a hoist or get assistance to lift this assembly.

If removed, install the crankshaft. Refer to Procedure Procedure 001-016

Install the block stiffener plate. Refer to Procedure Procedure 001-089

Install the lubricating oil suction tube. Refer to Procedure Procedure 007-035

Install the oil pan and oil pan gasket. Refer to Procedure Procedure 007-025

Fill the engine with clean lubricating oil. Refer to Procedure Procedure 007-037

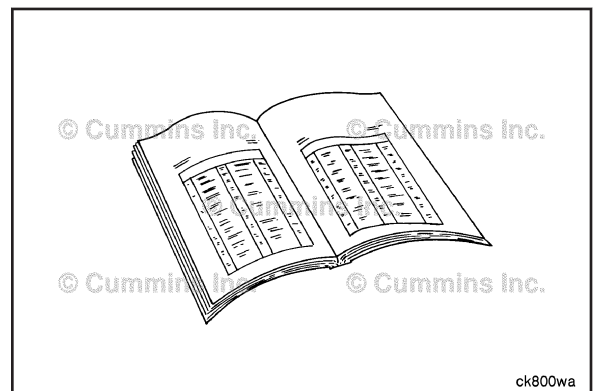

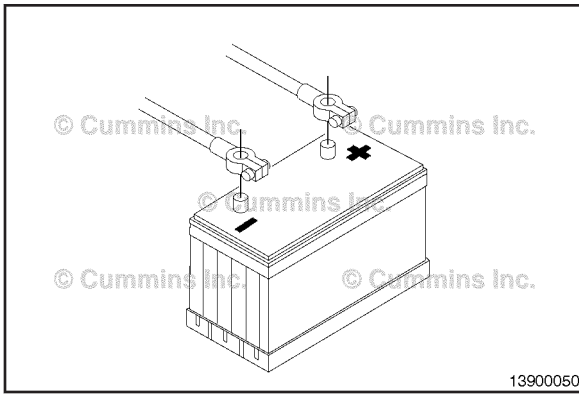

⚠ WARNING ⚠

Batteries can emit explosive gases. To reduce the possibility of personal injury, always ventilate the compartment before servicing the batteries. To reduce the possibility of arcing, remove the negative (-) battery cable first and attach the negative (-) battery cable last.

Connect the batteries.

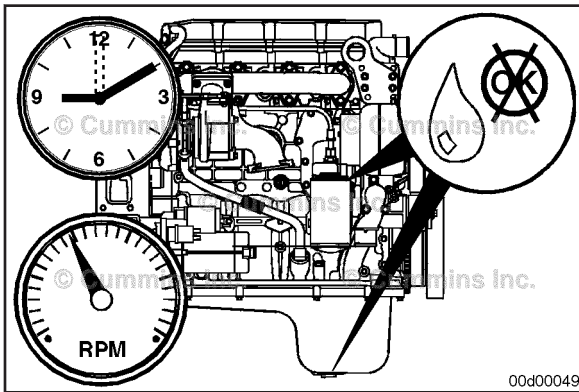

Operate the engine and check for leaks and proper oil pressure.

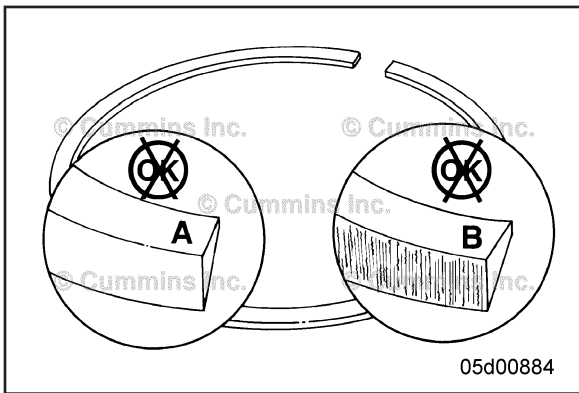

**Piston Rings (001-047)
Failure Analysis Inspection**

Inspect the piston rings for the following:

- Abrasive wear.

NOTE: Abrasive wear of the intermediate ring can be indicated by a rapid reduction of the dark finish coating on the front face of the ring, in some cases, to the point where the dark finish coating is no longer visible (A). This is commonly referred to as full face ring wear. This rapid reduction will typically leave a sharp edge on the bottom of the intermediate ring. Abrasive wear can also be indicated by concentrated vertical scratches on the top ring (B).

Abrasive wear can be caused by:

- 1 Ingested abrasive material
- 2 Inadequate cleaning during a previous repair
- 3 Particles embedded in the bore
- 4 High soot content in the lubricating oil from extended oil drain intervals
- 5 Scuffing and scoring.

NOTE: Scuffing and scoring is indicated by heavy scratches, metal discoloration, and voids (B).



Scuffing and scoring can be caused by:

- 1 Engine overheating
- 2 Oil dilution
- 3 Improper maintenance of the lubrication system
- 4 Piston cooling nozzle malfunction
- 5 Oil ring plugged by deposits.

NOTE: Scuffing and scoring on the piston rings indicates a breakdown of the oil film on the cylinder bore wall, causing transfer of material from the piston ring face to the cylinder bore.

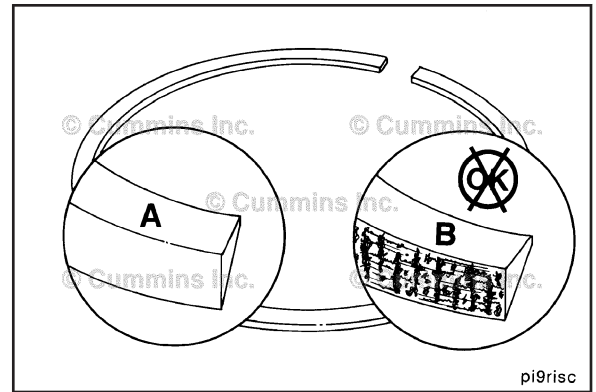

NOTE: Oil ring plugging is indicated by deposits on the oil ring grooves (B).



Oil ring plugging can be caused by:

- 1 Low engine operating temperatures - long periods of idling or a cooling system malfunction
- 2 Extended oil change intervals
- 3 Use of wrong grade of engine oil
- 4 Use of a poor quality engine oil.

NOTE: Plugging of the oil ring drains restricts oil drain back, which floods the piston ring belt area, resulting in a loss of oil control.

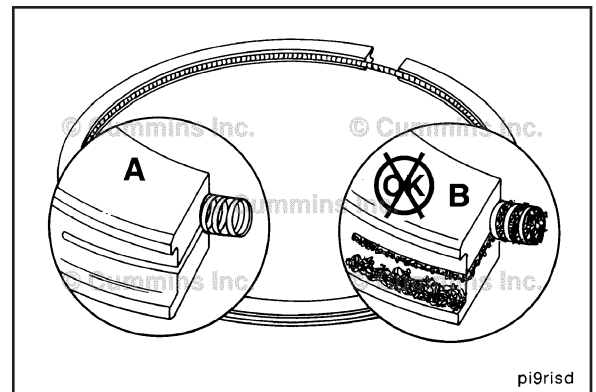

NOTE: The following measurements are intended for inspecting new piston rings.



NOTE: Before completing this inspection, make sure the cylinder bore is within specification. Refer to Procedure 001-026 in Section 1.



Measure the piston ring gap by installing the piston rings into the cylinder bore in which they will be used. Position the rings below the ring reversal area by positioning each ring in the cylinder 89 mm [3.5 in] below the top deck (A), and use a piston to square it with the bore.

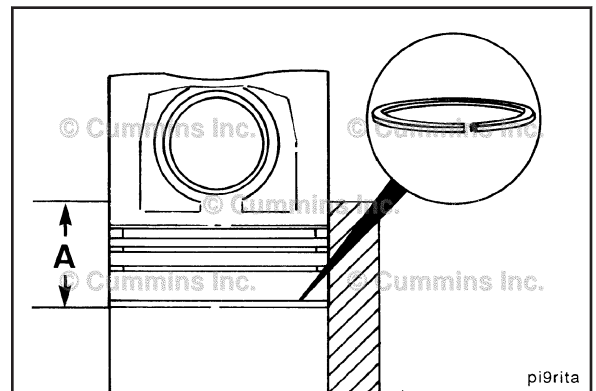

The piston ring type and location can be identified by piston ring profile.



- 1 Top piston ring
- 2 Intermediate piston ring
- 3 Oil control ring.

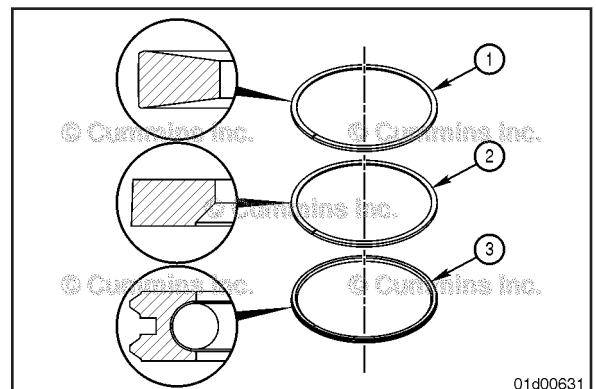

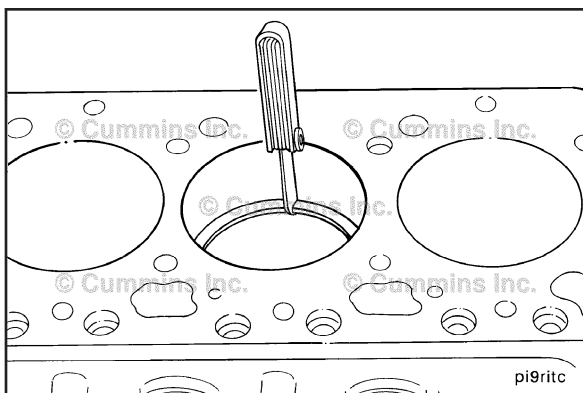

Use a feeler gauge to measure the gap.

3.9L and 5.9L Engines Ring Gap

	mm		in
Top	0.29	MIN	0.011
	0.58	MAX	0.023
Intermediate	0.88	MIN	0.035
	1.37	MAX	0.054
Oil	0.28	MIN	0.011
	0.77	MAX	0.030

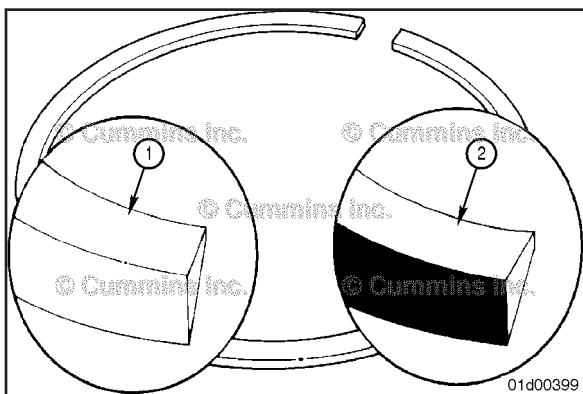

Two types of intermediate piston rings are used on 4.5L and 6.7L engines. The type of piston ring can be identified by the type of coating applied to the ring face.

- 1 The chrome faced intermediate piston ring will have a bare metal appearance.
- 2 The phosphate coated intermediate piston ring will have a black appearance.

4.5L and 6.7L Engines Ring Gap

	mm		in
Top	0.30	MIN	0.012
	0.46	MAX	0.018
Phosphate Coated Intermediate	0.82	MIN	0.032
	1.18	MAX	0.047
Chrome Faced Intermediate	0.52	MIN	0.021
	0.88	MAX	0.034
Oil	0.22	MIN	0.010
	0.58	MAX	0.023

If the piston ring gap is **not** within specification:

- 1 Verify the correct type and part number of the piston ring being used.
- 2 Verify the cylinder bore is within specification. Refer to Procedure 001-026 in Section 1.
- 3 Verify the piston ring gap measurement is being taken 89 mm or 3.5 in below the cylinder block deck.
- 4 Try another set of piston rings.

Vibration Damper, Rubber (001-051)

Preparatory Steps

⚠️ WARNING ⚠️

Batteries can emit explosive gases. To reduce the possibility of personal injury, always ventilate the compartment before servicing the batteries. To reduce the possibility of arcing, remove the negative (-) battery cable first and attach the negative (-) battery cable last.

Disconnect the batteries.

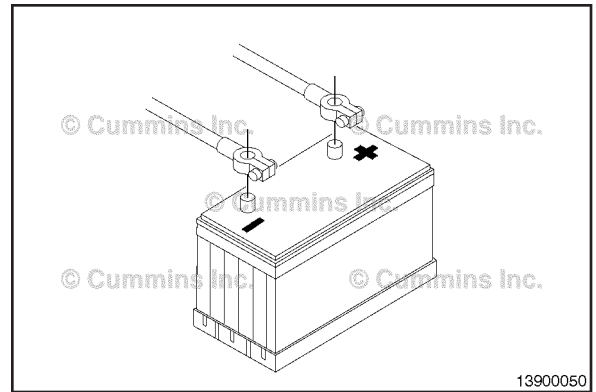

Remove the drive belt. Refer to Procedure Procedure 008-002

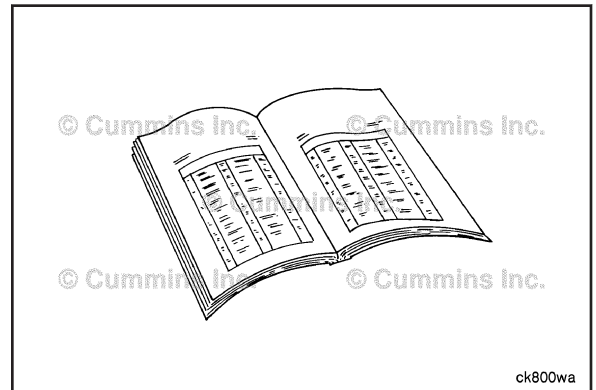

Remove

For front gear train engines, remove the four capscrews.

For rear gear train engines, remove the six capscrews.

NOTE: For 3.9 L and 5.9 L engines, the crankshaft speed indicator ring is held in place by the same capscrews as the vibration damper. For 4.5 L and 6.7 L, with a rear gear train, the crankshaft speed indicator ring is a part of the vibration damper assembly and should **not** be removed from the vibration damper.

Remove the vibration damper and crankshaft speed indicator ring.

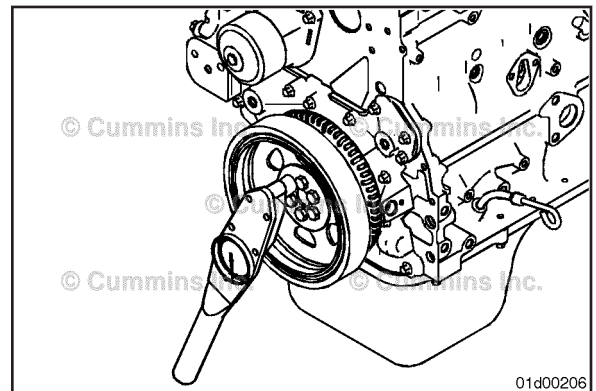

Clean and Inspect for Reuse

⚠️ WARNING ⚠️

Compressed air used for cleaning should not exceed 207 kPa[30 psi]. Wear protective clothing, goggles/shield, and gloves to reduce the possibility of personal injury.

Using soapy water, clean any oil from the crankshaft speed indicator ring and vibration damper.

Dry the crankshaft speed indicator ring and vibration damper with compressed air.

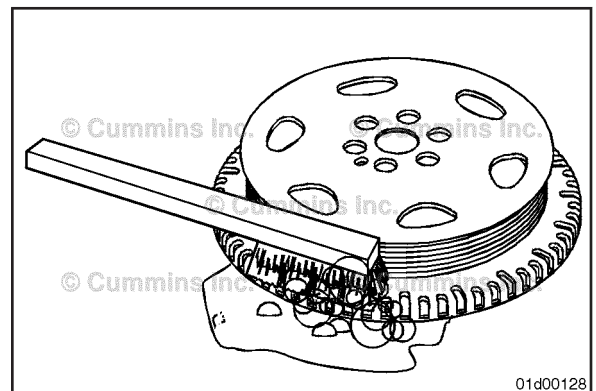

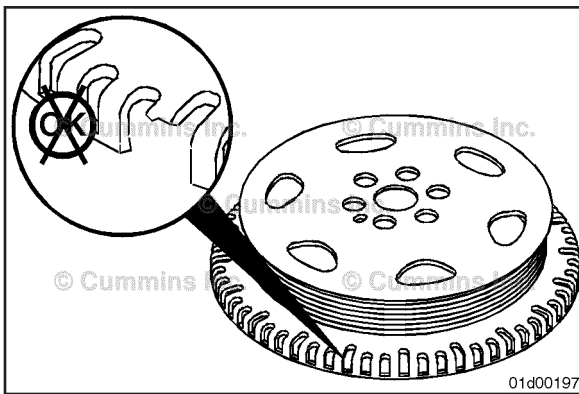

Inspect the crankshaft speed indicator ring for missing teeth, cracks, or damaged surfaces. If any damage is found, the crankshaft speed indicator ring **must** be replaced.

NOTE: For 4.5 L and 6.7 L engines, with a rear gear train, if the crankshaft speed indicator ring is found damaged, the whole vibration damper assembly **must** be replaced.

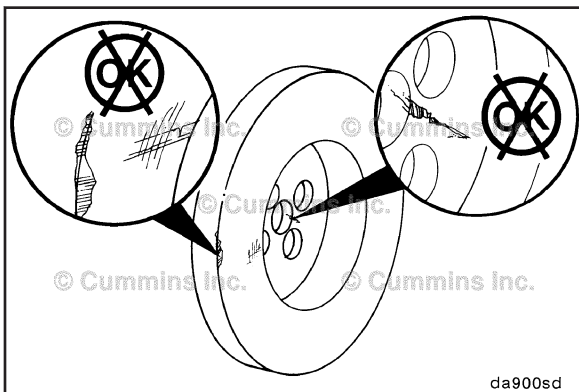

Check the mounting web for cracks.

Check the alignment marks on the inner and outer rings.

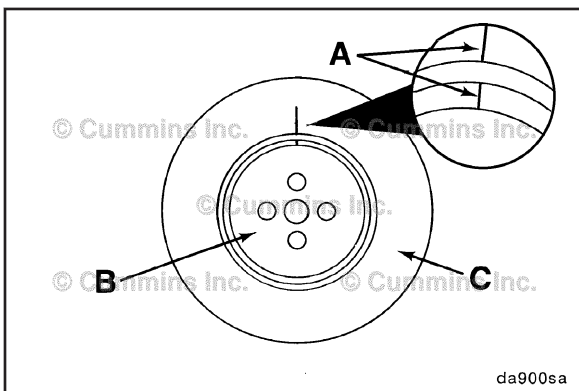

Check the index lines (A) on the damper hub (B) and the inertia member (C).

If the lines are more than 1.59-mm [1/16-in] out of alignment, replace the damper.

Inspect the vibration damper hub for cracks.

Replace the damper if the hub is cracked.

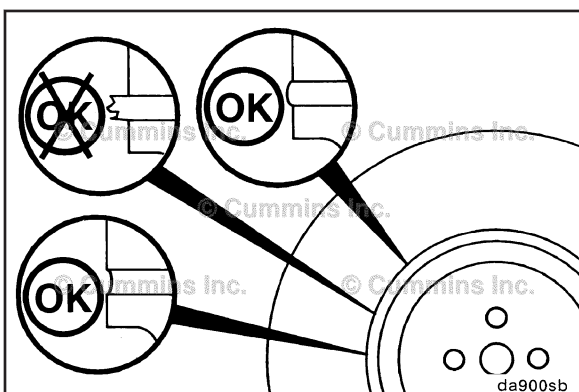

Inspect the rubber member for deterioration.

If pieces of rubber are missing or if the elastic member is more than 3.18 mm [1/8 in] below the metal surface, replace the vibration damper.

NOTE: Look for forward movement of the damper ring on the hub. Replace the damper if any movement is detected.

Install

NOTE: Align the crankshaft speed indicator ring, and vibration damper with the index pin located on the nose of the crankshaft.

Lubricate bolts with clean engine oil.

Install the vibration damper and crankshaft speed indicator ring.

For front gear train engines, tighten the four damper capscrews in a criss-cross pattern.

Torque Value:

Step 1 40 N•m [30 ft-lb]
Step 2 Rotate 60 degrees

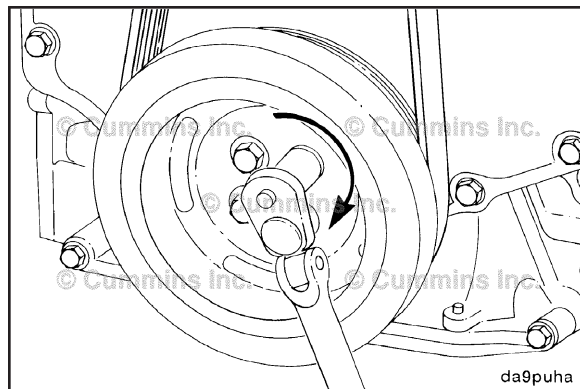

For rear gear train engines, tighten the six vibration damper capscrews in a criss-cross pattern.

Torque Value:

Step 1 50 N•m [37 ft-lb]
Step 2 Rotate 90 degrees

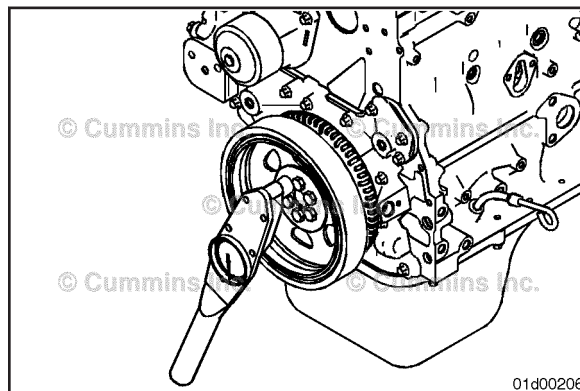

Finishing Steps

Install the drive belt. Refer to Procedure Procedure 008-002

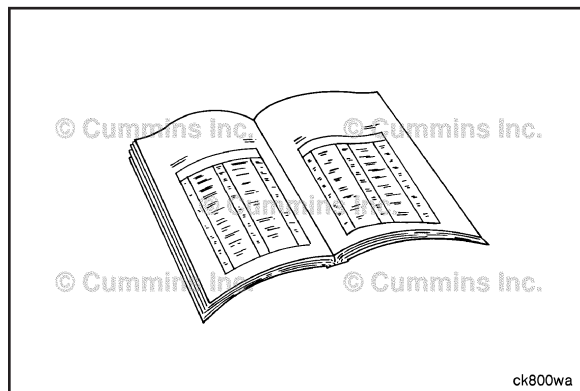

⚠ WARNING ⚠

Batteries can emit explosive gases. To reduce the possibility of personal injury, always ventilate the compartment before servicing the batteries. To reduce the possibility of arcing, remove the negative (-) battery cable first and attach the negative (-) battery cable last.

Connect the batteries.

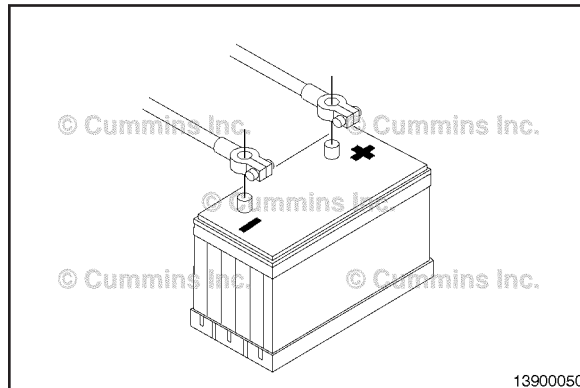

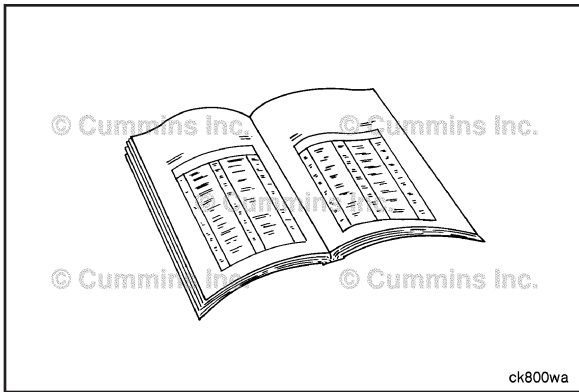

Vibration Damper, Viscous (001-052)

Preparatory Steps



▲ WARNING ▲

Batteries can emit explosive gases. To reduce the possibility of personal injury, always ventilate the compartment before servicing the batteries. To reduce the possibility of arcing, remove the negative (-) battery cable first and attach the negative (-) battery cable last.

- Disconnect the batteries. Refer to Procedure 013-009
- On marine applications, remove the belt guards. Refer to Procedure 008-001

NOTE: The drive belt on marine applications can be removed from the vibration damper pulley without removing the sea water pump drive belt.

- Remove the drive belt. Refer to Procedure 008-002

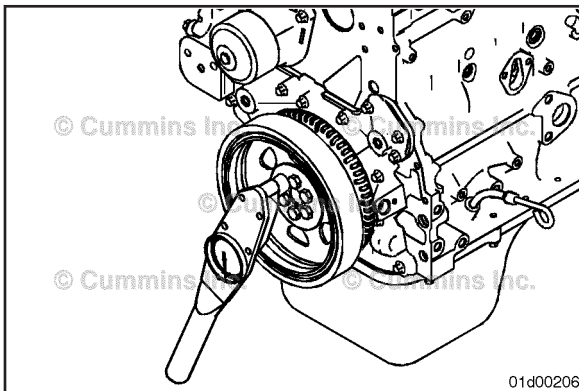

Remove

For front gear train engines, remove the four capscrews.

For rear gear train engines, remove the six capscrews.

NOTE: For 3.9 L and 5.9 L engines, the crankshaft speed indicator ring is held in place by the same capscrews as the vibration damper. For 4.5 L and 6.7 L, with a rear gear train, the crankshaft speed indicator ring is a part of the vibration damper assembly and should **not** be removed from the vibration damper.

Remove the vibration damper.

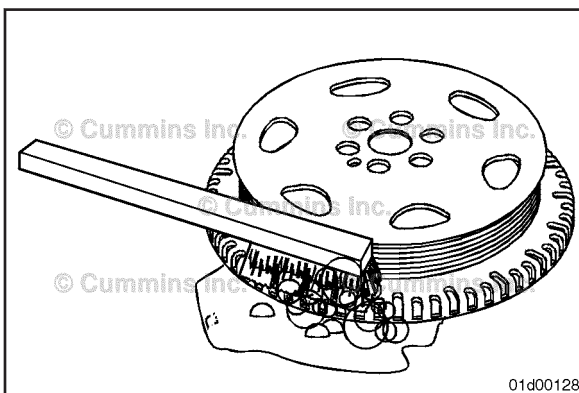

Clean and Inspect for Reuse

▲ WARNING ▲

Compressed air used for cleaning should not exceed 207 kPa [30 psi]. Wear protective clothing, goggles/shield, and gloves to reduce the possibility of personal injury.

Using soapy water, clean any oil from the crankshaft speed indicator ring and vibration damper.

Dry the crankshaft speed indicator ring and vibration damper with compressed air.

Inspect the crankshaft speed indicator ring for missing teeth, cracks, or damaged surfaces. If any damage is found, the crankshaft speed indicator ring **must** be replaced.

NOTE: For 4.5 L and 6.7 L engines, with a rear gear train, if the crankshaft speed indicator ring is found damaged, the whole vibration damper assembly must be replaced.

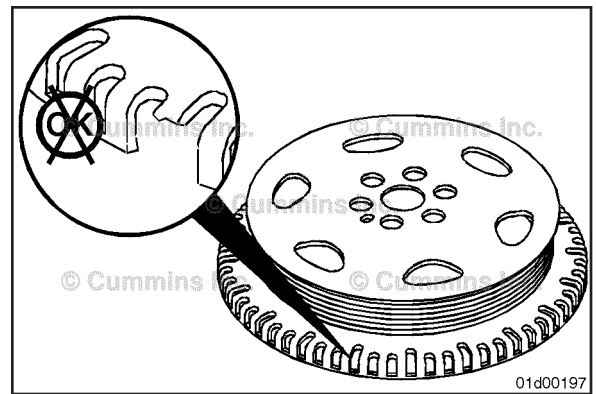

Check the mounting web for cracks.

Check the housing for dents or raised surfaces.

Replace the damper if any of these defects are identified

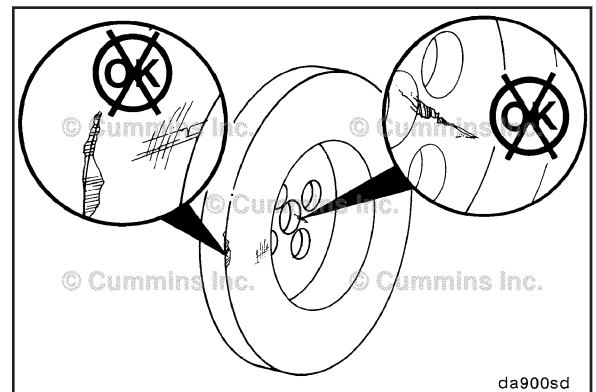

NOTE: The viscous damper is filled with a silicone fluid. After many hours of use, the silicone fluid can become thicker and expand.

To determine if the damper thickness is correct, remove the paint from the damper in four locations on either side of the damper.

Measure and record the thickness of the damper in four places. Measure the thickness at 80.65 mm [3.175 in] from the outside of the damper.

Replace the damper if its thickness varies by more than 6.35 mm [0.25 in].

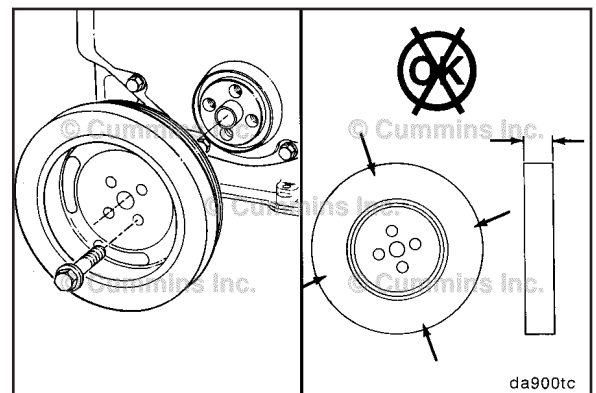

Spray the damper with spot check developer, type SKD-NF, or its equivalent.

Heat the damper in an oven, rolled-lip side down, at 93°C [200°F] for 2 hours.

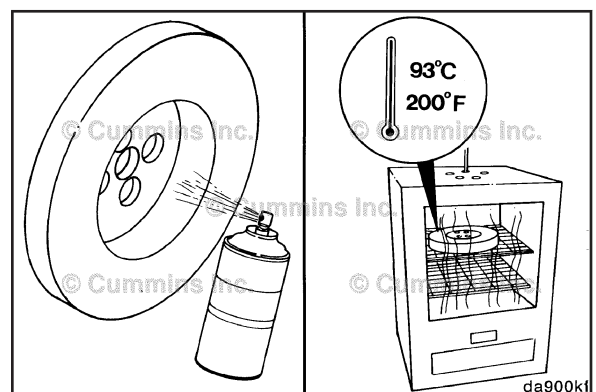

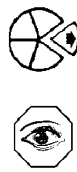
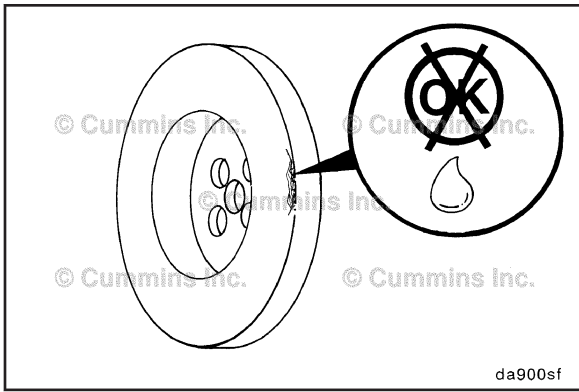

▲ WARNING ▲

Wear protective gloves to reduce the possibility of personal injury when handling parts that have been heated.

Remove the damper from the oven and check for fluid leakage.

If there is leakage, the vibration damper **must** be replaced.

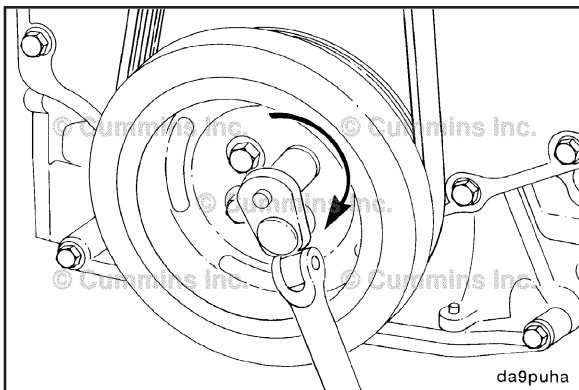

Install

NOTE: Align the crankshaft speed indicator ring, and vibration damper with the index pin located on the nose of the crankshaft.

Lubricate bolts with clean engine oil.

Install the vibration damper and crankshaft speed indicator ring.

For front gear train engines, tighten the four damper capscrews in a criss-cross pattern.

Torque Value:

Step 1	40 N•m	[30 ft-lb]
Step 2	Rotate 60 degrees	

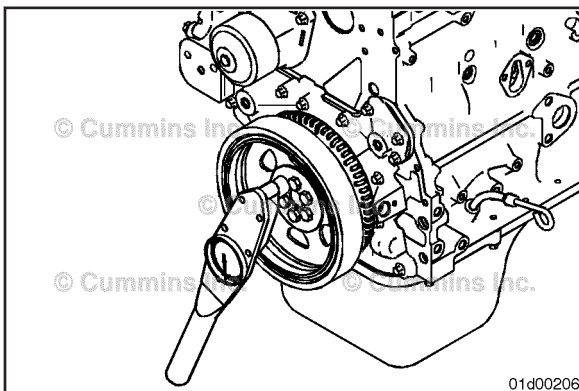

For rear gear train engines, tighten the six vibration damper capscrews in a criss-cross pattern.

Torque Value:

Step 1	50 N•m	[37 ft-lb]
Step 2	Rotate 90 degrees	

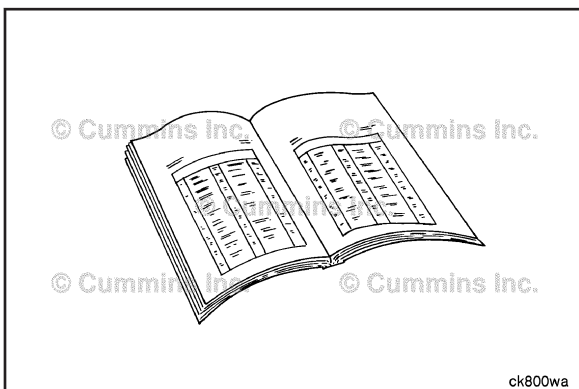

Finishing Steps

▲ WARNING ▲

Batteries can emit explosive gases. To reduce the possibility of personal injury, always ventilate the compartment before servicing the batteries. To reduce the possibility of arcing, remove the negative (-) battery cable first and attach the negative (-) battery cable last.

- Install the drive belt. Refer to Procedure 008-002
- Connect the batteries. Refer to Procedure 013-009
- On marine applications, install the belt guards. Refer to Procedure 008-001

Piston and Connecting Rod Assembly (001-054)

General Information

Different types of connecting rods are used in B series engines, depending on the plant and time the engine was built. **Not** all connecting rods are interchangeable. When replacing a connecting rod, make sure it matches the other connecting rods. All the connecting rods in the engine **must** be the same.

Not all connecting rods have the part number located on the connecting rod. It may be necessary to identify physical characteristics of the connecting rod when matching it to existing connecting rods.

- 1 Balance weight on the connecting rod cap
- 2 Protrusion on the short side of the connecting rod
- 3 Smooth edge on the short side of the connecting rod
- 4 I-beam design.

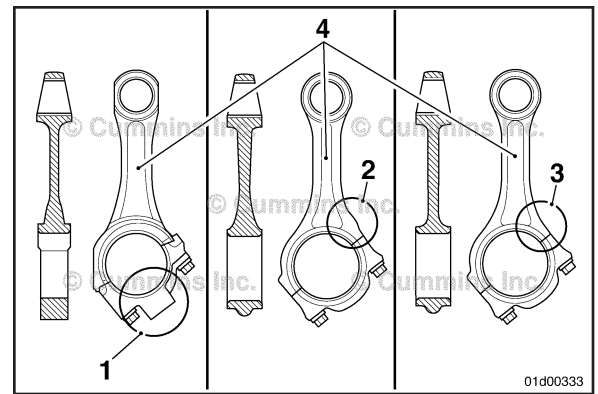

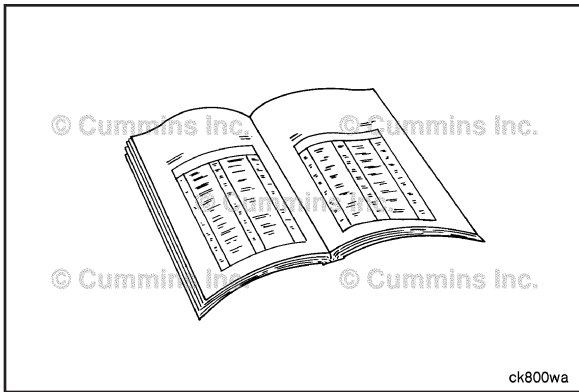

Preparatory Steps

⚠️ WARNING ⚠️

Batteries can emit explosive gases. To reduce the possibility of personal injury, always ventilate the compartment before servicing the batteries. To reduce the possibility of arcing, remove the negative (-) battery cable first and attach the negative (-) battery cable last.

⚠️ WARNING ⚠️

Some state and federal agencies have determined that used engine oil can be carcinogenic and can cause reproductive toxicity. Avoid inhalation of vapors, ingestion, and prolonged contact with used engine oil.

⚠️ WARNING ⚠️

To reduce the possibility of personal injury avoid direct contact of hot oil with your skin.

⚠️ WARNING ⚠️

Coolant is toxic. Keep away from children and pets. If not reused, dispose of in accordance with local environmental regulations.

⚠️ WARNING ⚠️

Do not remove the pressure cap from a hot engine. Wait until the coolant temperature is below 50°C [120°F] before removing the pressure cap. Heated coolant spray or steam can cause personal injury.

Disconnect the battery cables.

Drain the lubricating oil. Refer to Procedure 007-037

Remove the lubricating oil pan and gasket. Refer to Procedure 007-025

Remove lubricating oil suction tube. Refer to Procedure 007-035

Remove the block stiffener plate. Refer to Procedure 001-089

If the engine is equipped with J-jet piston cooling nozzles, they **must** be removed to prevent component damage. Refer to Procedure 001-046

Drain the coolant. Refer to Procedure 008-018

Remove the cylinder head. Refer to Procedure 002-004

Remove

⚠ WARNING ⚠

When using solvents, acids, or alkaline materials for cleaning, follow the manufacturer's recommendations for use. Wear goggles and protective clothing to reduce the possibility of personal injury.

⚠ WARNING ⚠

Some solvents are flammable and toxic. Read the manufacturer's instructions before using.

Rotate the crankshaft until the pistons are below the carbon deposits that are found above the ring travel area.

Use a fine fibrous abrasive pad, Part Number 3823258 or equivalent, and solvent to remove the carbon.

Mark each piston according to the cylinder location.

NOTE: On pistons with anodized coatings, do **not** stamp on the anodized coating or on the outer rim. Do **not** stamp on the aluminum piston crown above the piston pin axis.

Rotate the crankshaft to position the rod caps at bottom dead center for removal.

Mark each connecting rod and rod cap according to the cylinder number location.

Some engines are equipped with an external Torx bit (E-12).

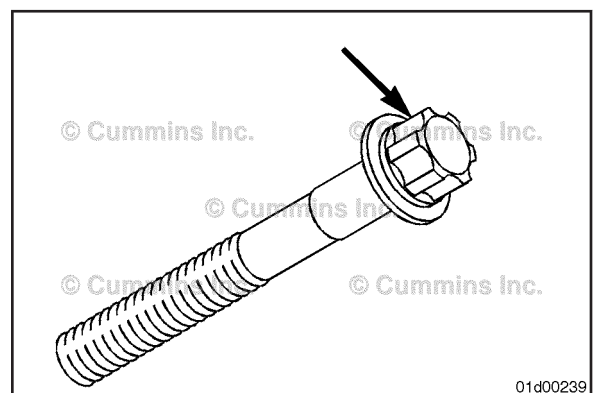
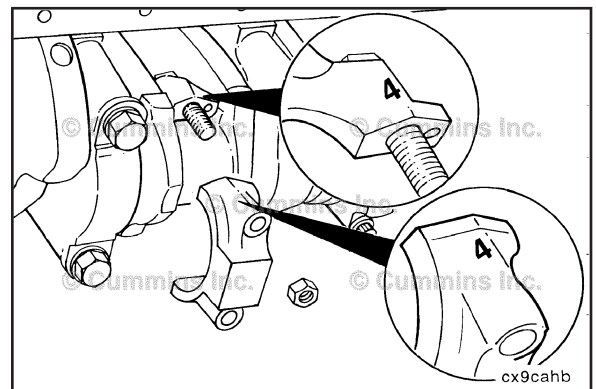
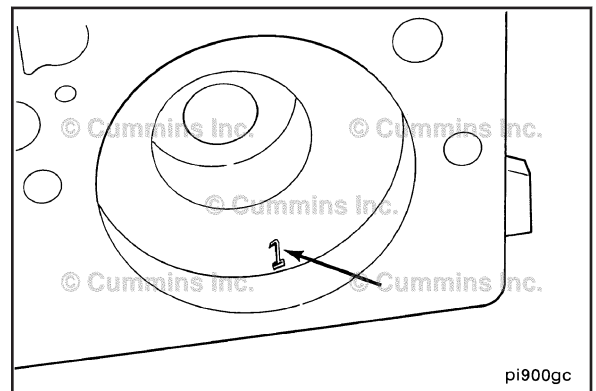
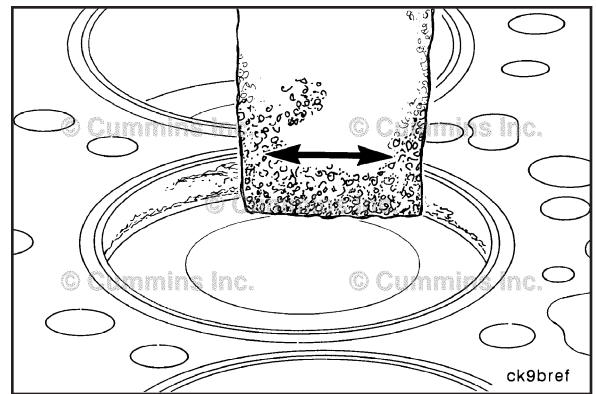

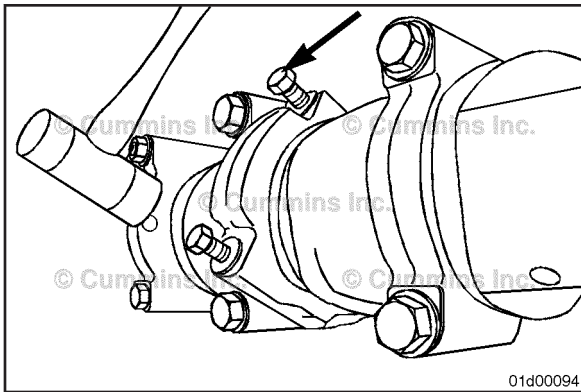

Loosen the connecting rod capscrews.

Do **not** remove the capscrews from the rods at this time.

Use a rubber hammer to hit the connecting rod capscrews to loosen the caps.

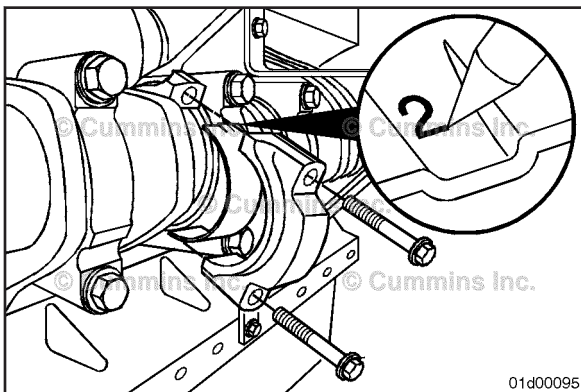

⚠ CAUTION ⚠

Do not damage the fractured split surface on the connecting rod or connecting rod cap while the connecting rod cap is removed. If the fractured split surface is damaged, the connecting rod and connecting rod cap must be replaced to help reduce the possibility of engine damage. Incorrect assembly can damage the rod.

⚠ CAUTION ⚠

When setting the rod cap down, do not set the cap down on the fractured split surface. Damage to the fractured split surface can result.

Remove the connecting rod capscrews.

Remove the rod cap.

Remove the lower rod bearing.

Mark the cylinder number and the letter "L" (lower) on the flat surface of the bearing tang.

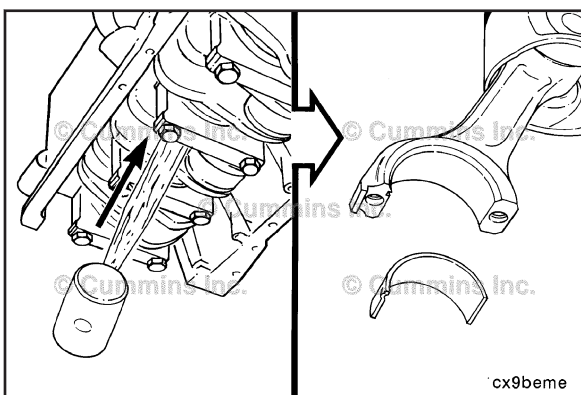

Push the connecting rod and piston assembly out of the cylinder bore. Care **must** be taken **not** to damage the connecting rod or bearing.

Remove the upper rod bearing.

Mark the cylinder number and the letter "U" (upper) on the flat surface of the bearing tang.

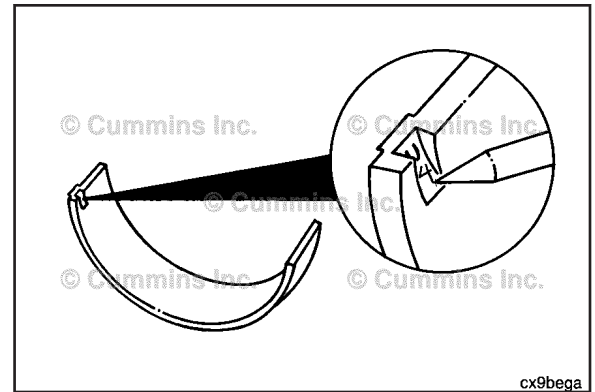

The piston and connecting rod assemblies **must** be installed in the same cylinder number they were removed from to provide for proper fit of worn mating surfaces if parts are reused.

Use a tag to mark the cylinder number that each piston and rod assembly was removed from.

Place the rod and piston assemblies in a container to protect them from damage.

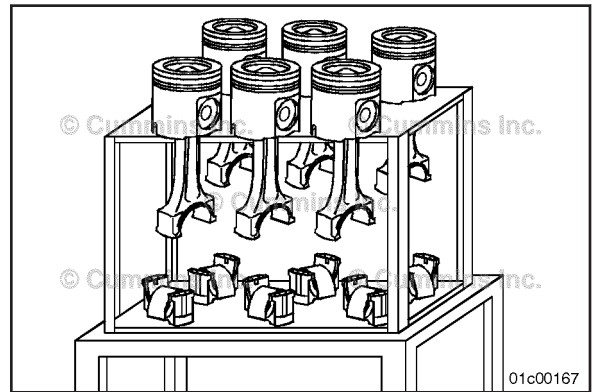

Disassemble

Using piston ring expander, Part Number 3823137, remove the piston rings.

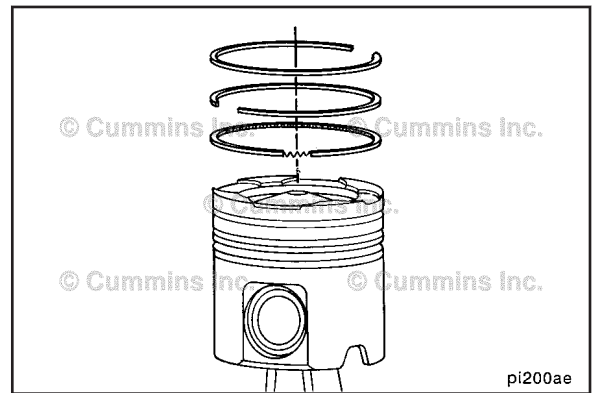

Use internal snap ring pliers to remove the snap rings from both sides of the piston.

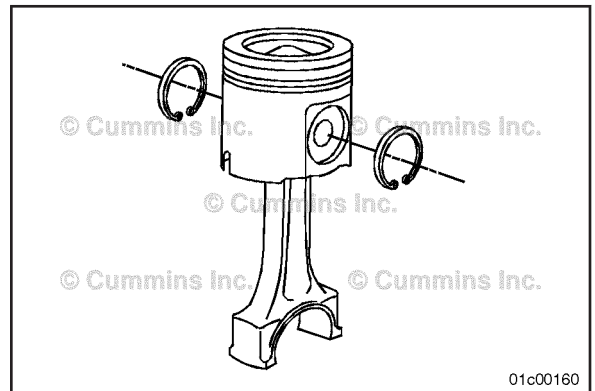

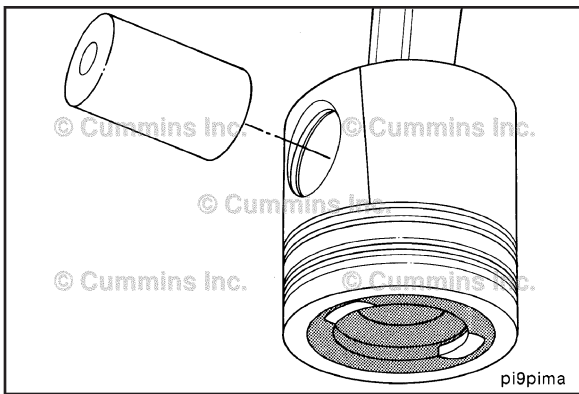

Remove the piston pin.
Heating the piston is **not** required.
Remove the connecting rod from the piston.

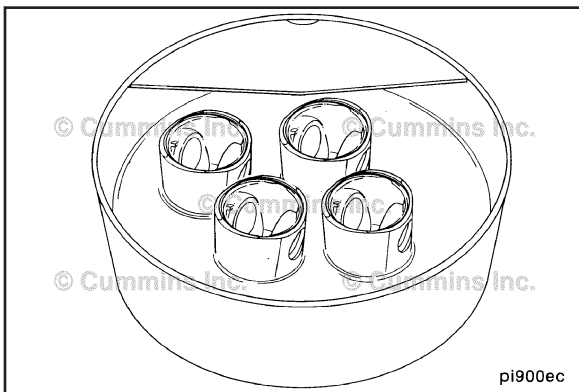

Clean and Inspect for Reuse

Clean and inspect the pistons and piston pins. Refer to Procedure 001-043

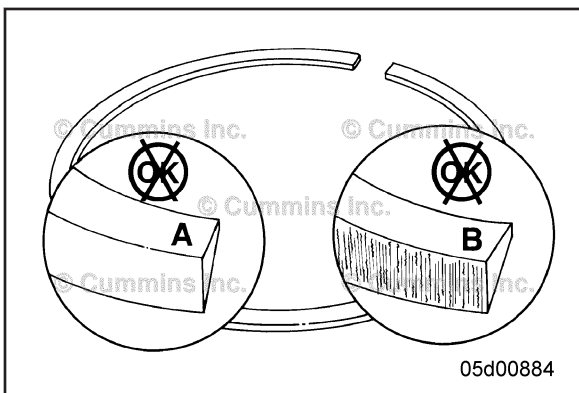

Inspect the piston rings. Refer to Procedure 001-047

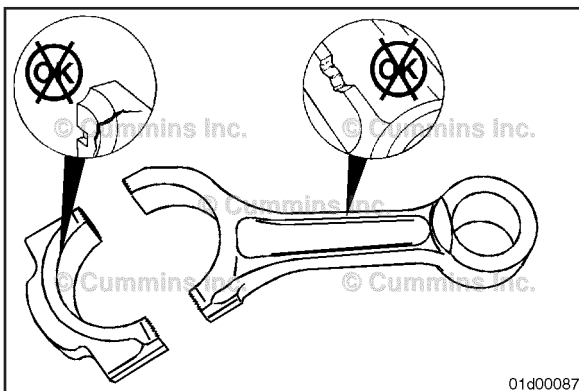

Inspect the connecting rods. Refer to Procedure 001-014



Assemble

Install the retaining ring in the pin groove on one side of the piston.

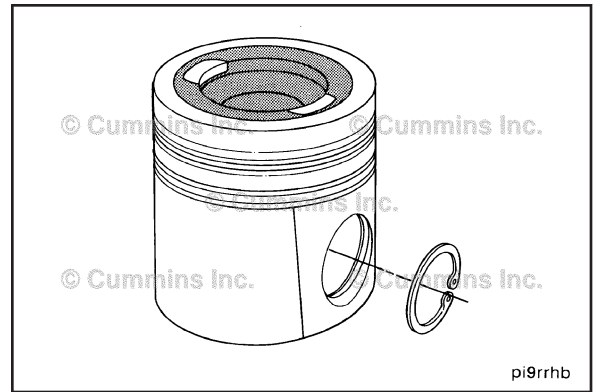

Lubricate the pin and pin bores with engine lubricating oil.

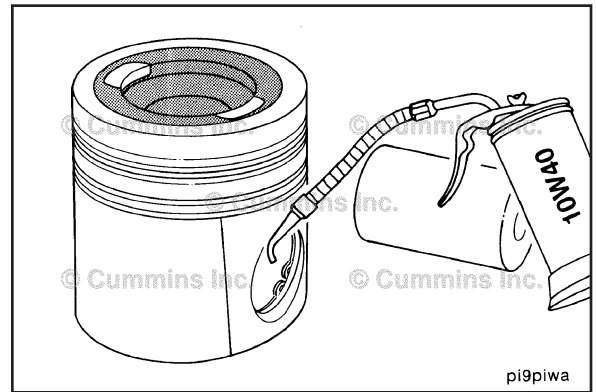

3.9 L and 5.9 L Engines

NOTE: The piston **must** be installed onto the connecting rod with the correct orientation. The orientation of the piston onto the connecting rod for 4.5 L and 6.7 L engines is different than 3.9 L and 5.9 L engines.

Hold the connecting rod so that the angle split of the connecting rod faces away from you. Install the piston onto the connecting rod so that the 'Front' mark and/or arrow are on the left side of the connecting rod. The notch at the bottom of the piston on the piston skirt will face away from you.

Assemble the piston onto the connecting rod.

NOTE: Pistons do **not** require heating to install the pin, however, the pistons do need to be at room temperature or above.

Install the pin through the piston and connecting rod.

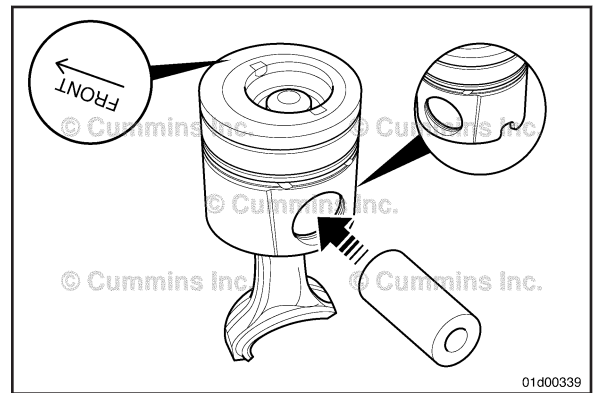

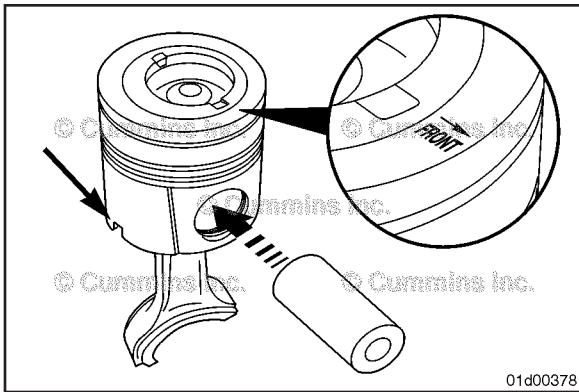

4.5 L and 6.7 L Engines

NOTE: The piston **must** be installed onto the connecting rod with the correct orientation. The orientation of the piston onto the connecting rod for 4.5 L and 6.7 L engines is different than 3.9 L and 5.9 L engines.

Hold the connecting rod so that the angle split of the connecting rod faces away from you. Install the piston onto the connecting rod so that the 'Front' mark and/or arrow are on the right side of the connecting rod. The notch at the bottom of the piston on the piston skirt will face towards you.

Assemble the piston onto the connecting rod.

NOTE: Pistons do **not** require heating to install the pin, however, the pistons do need to be at room temperature or above.

Install the pin through the piston and connecting rod.

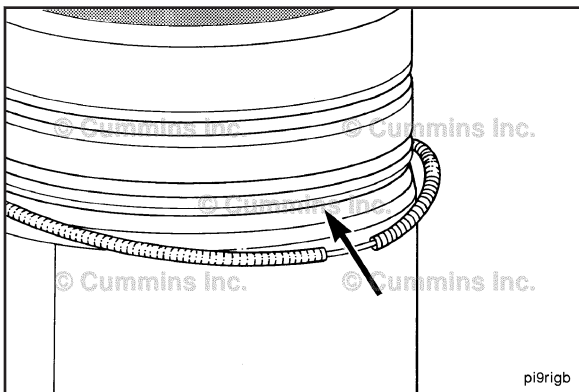

Start by positioning the oil ring expander in the oil control ring groove. Then install the oil control ring, followed by the intermediate ring and finally the top ring.

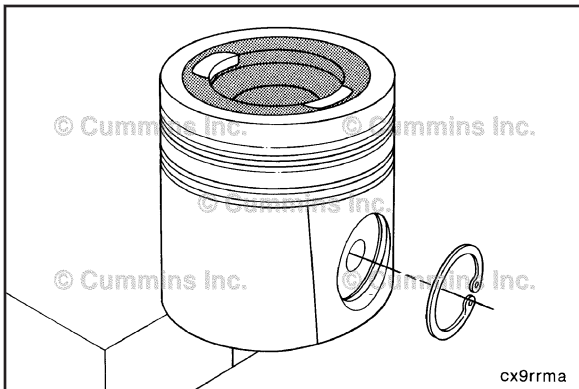

Install the second retaining ring.

⚠ CAUTION ⚠

Most piston rings look similar but have significant differences. Make sure the correct part number is being used for the engine.

The top surface of the upper and intermediate rings are identified either with the word "TOP" or a supplier identification mark, such as a stamped dot. Assemble with the word "TOP" or the supplier mark facing upward.

The bottom, or oil control ring, can be installed with either side up.

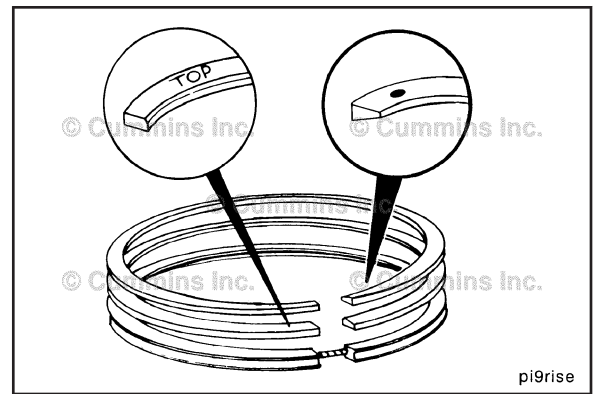

The two-piece oil control ring **must** be installed with the expander ring gap 180-degrees from the gap of the oil ring.

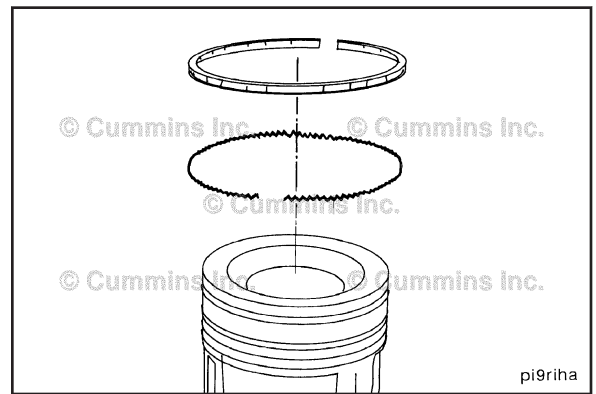

Using piston ring expander, Part Number 3823137, install the rings on the piston.

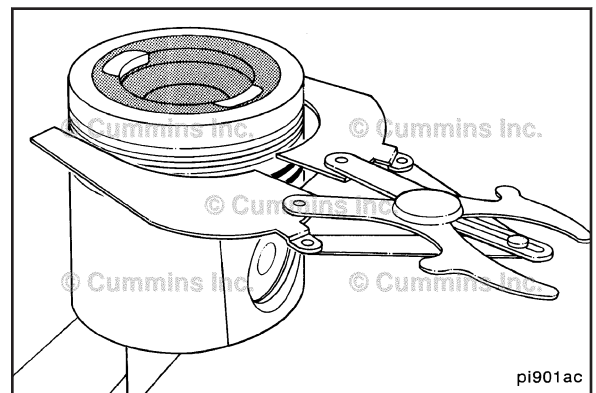

The piston ring type and location can be identified by piston ring profile.



- 1 Top Piston Ring
- 2 Intermediate Piston Ring
- 3 Oil Control Ring.

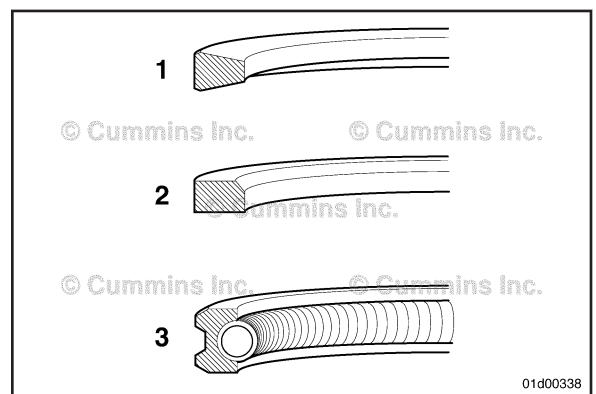

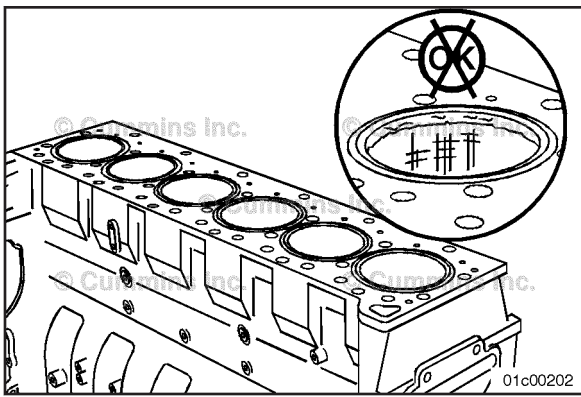

Install

The cylinder block and all parts **must** be clean before assembly. Refer to Procedure 001-026 to inspect the cylinder walls of the cylinder block.



Use a clean, lint-free cloth to clean the connecting rods and bearing shells.

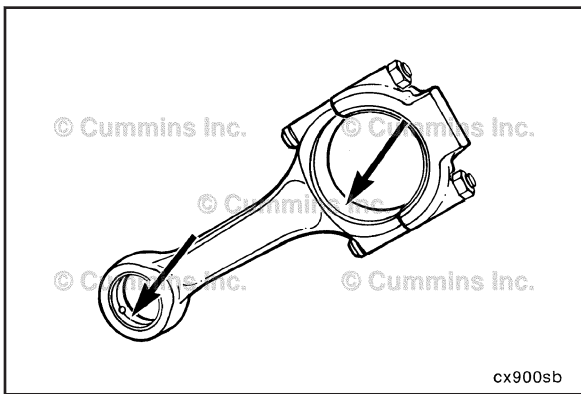

If new bearings are **not** used, the used bearings **must** be installed on the same connecting rod and location from where they were removed.



Make sure the connecting rod and backside of the connecting rod bearing surfaces are clean and free of debris. Do **not** lubricate the backside of the connecting rod bearings.

Install the upper bearing shell into the connecting rod.

The tang of the bearing shell **must** be in the slot of the rod. The end of the bearing shell **must** be even with the cap mounting surface.

The upper and lower rod bearing shells are **not** interchangeable on fracture split connecting rods.

NOTE: If the connecting rod bushing is removed for any reason, a new bushing **must** be used.

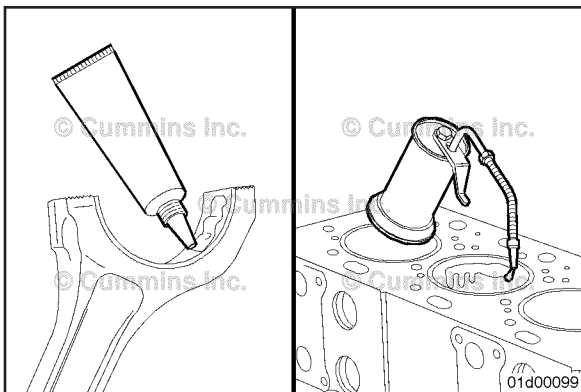

Use assembly lube, Part Number 3163087, or equivalent, to coat the inside circumference of the bearing shell.

Apply a film of clean 15W-40 oil to the cylinder block wall.

Lubricate the rings and piston skirts with clean engine lubricating oil.

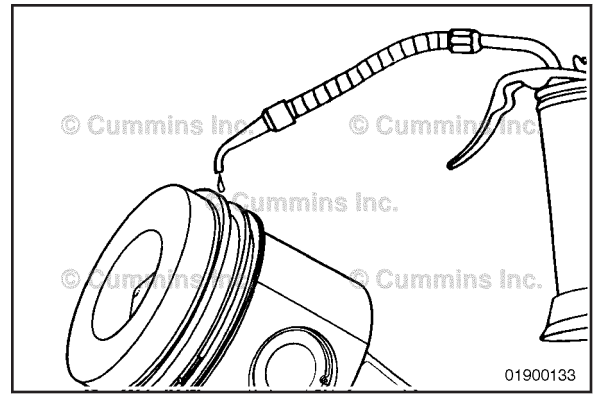

Rotate the rings to position the ring gaps as shown.

The ring gap of each ring **must not** be aligned with the piston pin, or with any other ring. If the ring gaps are **not** aligned correctly, the rings will **not** seal properly.

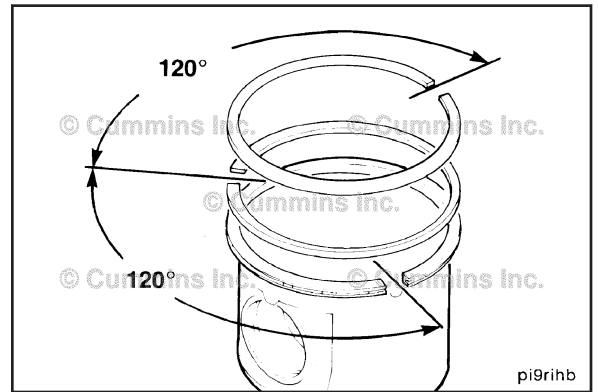

For 3.9 L and 5.9 L engines, use piston ring compressor, Part Number 3164330, to compress the rings.

For 4.5 L and 6.7 L engines, use piston ring compressor, Part Number 4918294, to compress the rings.

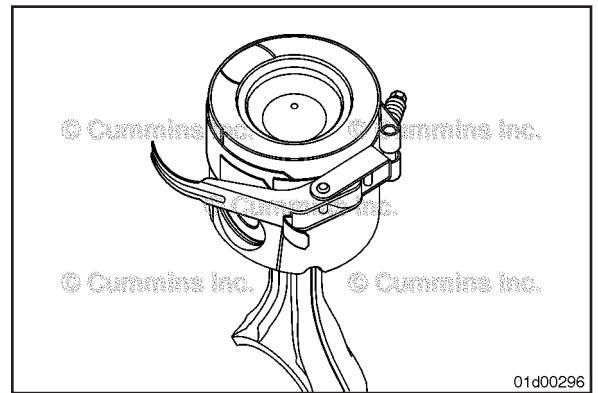

Rotate the crankshaft so the connecting rod journal of the connecting rod being installed is at bottom dead center.

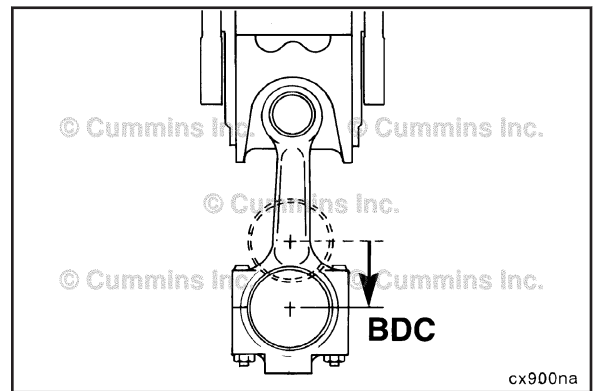

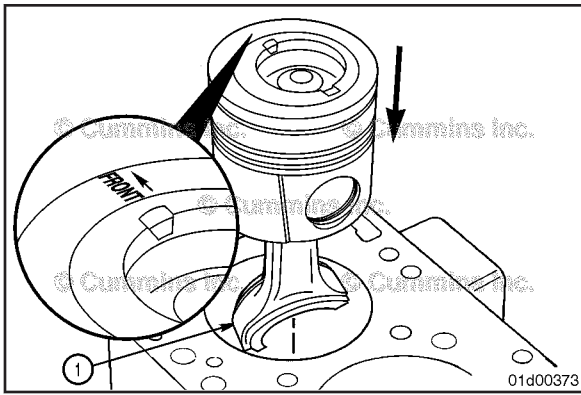

⚠CAUTION⚠

Failure to follow this step will result in extensive engine damage.

3.9 L and 5.9 L Engines

NOTE: The piston and connecting rod assembly **must** be installed with the correct orientation. The orientation of the piston and connecting rod assembly for 4.5 L and 6.7 L engines is different than 3.9 L and 5.9 L engines covered by this manual.

Align the "Front" marking and/or arrow on the top of the piston so that it points towards the front of the engine. Insert the connecting rod through the cylinder bore until the ring compressor contacts the top of the cylinder block.

The long end of the connecting rod (1) will be on the intake side of the engine. If **not**, verify the piston is installed correctly onto the connecting rod.

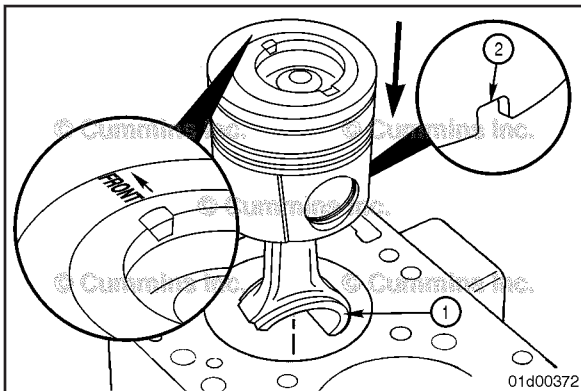

⚠CAUTION⚠

Failure to follow this step will result in extensive engine damage.

4.5 L and 6.7 L Engines

NOTE: The piston and connecting rod assembly **must** be installed with the correct orientation. The orientation of the piston and connecting rod assembly for 4.5 L and 6.7 L engines is different than 3.9 L and 5.9 L engines covered by this manual.

Align the "Front" marking and/or arrow on the top of the piston so that it points towards the front of the engine. Insert the connecting rod through the cylinder bore until the ring compressor contacts the top of the cylinder block.

The long end of the connecting rod (1) and the notch in the piston skirt (2) will be on the exhaust side of the engine. If **not**, verify the piston is installed correctly onto the connecting rod.

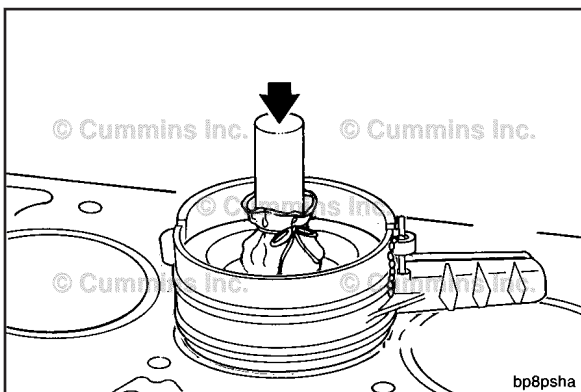

Hold the ring compressor against the cylinder block.

Push the piston through the ring compressor and into the cylinder bore.

Push the piston until the top ring is completely in the cylinder bore.

NOTE: If the piston does **not** move freely, remove the piston and inspect for broken or damaged rings.

Carefully push the piston into the bore while guiding the connecting rod to the crankshaft journal.

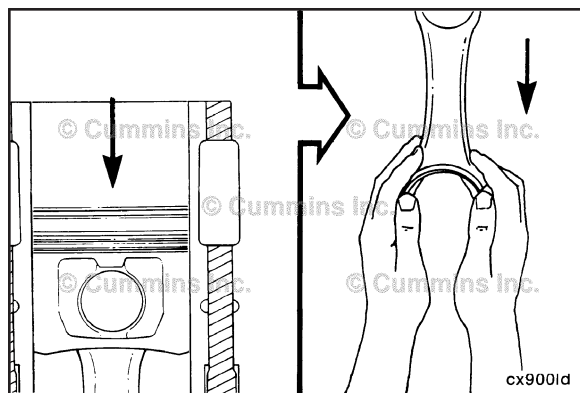

NOTE: If new bearings are **not** used, the used bearings **must** be installed on the same connecting rod cap from which they were removed.



Install the bearing in the connecting rod cap.

The tang of the bearing (2) **must** be in the slot of the cap (1).



Use assembly lube, Part Number 3163087, or equivalent, to coat the inside diameter of the bearing shell.

Use clean 15W-40 oil to lubricate the connecting rod capscrew threads and the underside of the connecting rod capscrew threads.

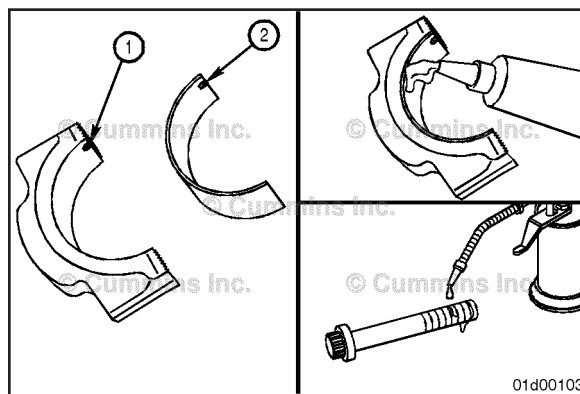

CAUTION

Do not damage the fractured split surface on the connecting rod or connecting rod cap while the connecting rod cap is removed. If the fractured split surface is damaged, the connecting rod and connecting rod cap **must** be replaced to help reduce the possibility of engine damage.



The connecting rod and cap **must** have the same number and **must** be installed in the proper cylinder. The connecting rod cap number and rod number **must** be on the same side of the connecting rod to prevent engine damage during engine operation.



Install the connecting rod cap and capscrews.

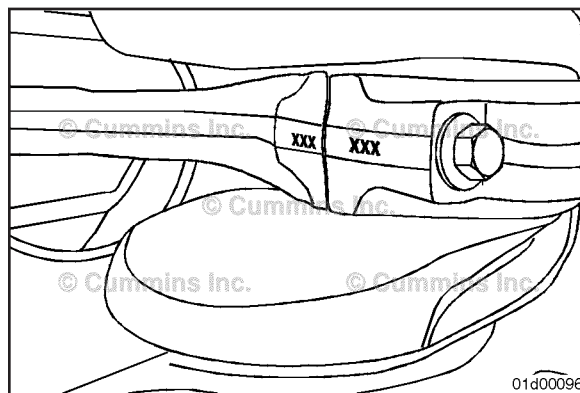

Use a marked socket and torque wrench to tighten the rod capscrews.



Using the torque plus angle method, tighten the connecting rod capscrews in alternating sequence.

Torque Value:

- Step 1 30 N•m [22 ft-lb]
- Step 2 60 N•m [44 ft-lb]
- Step 3 Rotate 60 degrees clockwise

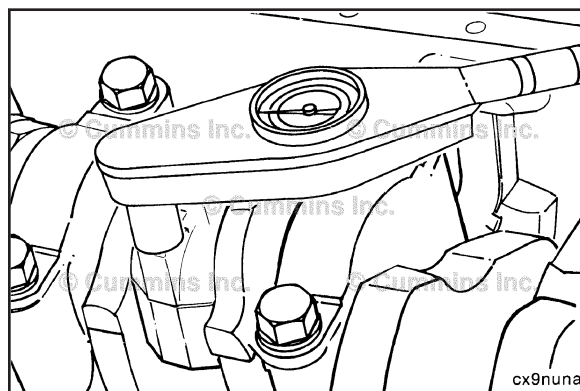

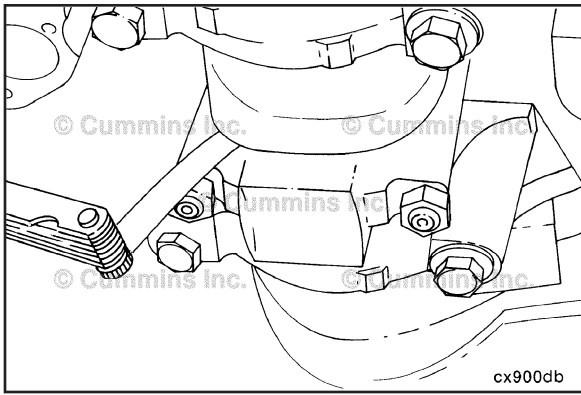

Do **not** measure the clearance between the rod cap and crankshaft.

Measure the side clearance between the connecting rod and crankshaft.

Connecting Rod and Crankshaft Side Clearance

mm		in
0.10	MIN	0.004
0.33	MAX	0.013

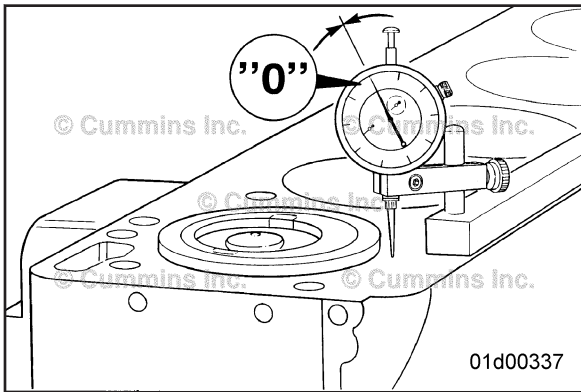

Measure piston protrusion above the cylinder block combustion deck.

NOTE: This procedure is only required after a piston, crankshaft, connecting rod, or block modification/replacement.

For 3.9 L and 5.9 L engines, Refer to Procedure 002-021. This procedure will determine the correct grade of head gasket to install.

For 4.5 L and 6.7 L engines, measure the piston protrusion using depth gauge assembly Part Number 3823495. No piston or head gasket grading is required.

Install the dial indicator on the cylinder head and zero.

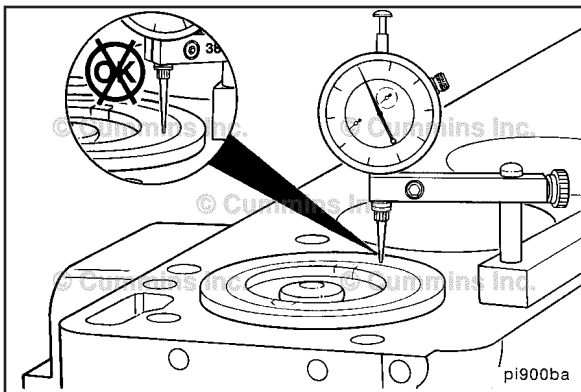

Move the dial indicator directly over the piston pin to eliminate any side-to-side movement. Do **not** place the indicator tip on the anodized area.

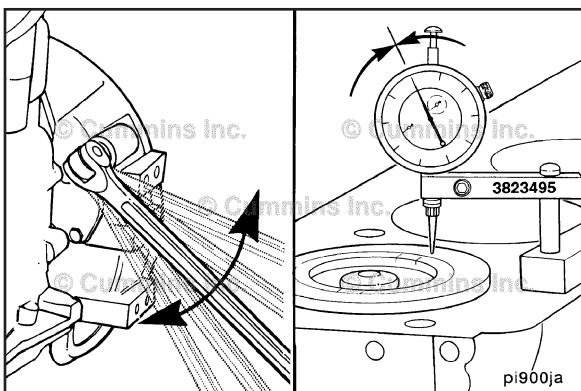

Rotate the crankshaft to top dead center. Rotate the crankshaft clockwise and counterclockwise to find the highest dial indicator reading. Record the reading.

Piston Protrusion

mm		in
0.151	MIN	0.006
0.485	MAX	0.019

If the piston protrusion is **not** within specification, verify that the correct parts are installed and/or the cylinder block combustion deck has been machined improperly. Refer to Procedure 001-026

Check for freedom of rotation as the connecting rod caps are installed. If the crankshaft does **not** rotate freely, check the installation of the connecting rod bearings and the bearing size.

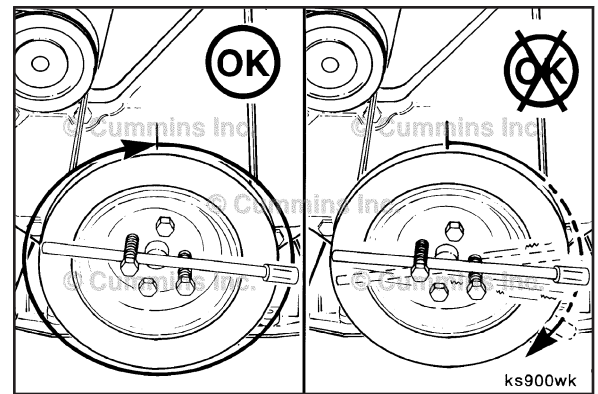

Finishing Steps

If removed, install the J-jet piston cooling nozzles. Refer to Procedure 001-046

Install the lubricating oil suction tube. Refer to Procedure 007-035

Install the block stiffener plate. Refer to Procedure 001-089

Install the lubricating oil pan. Refer to Procedure 007-025

Install the cylinder head. Refer to Procedure 002-004

Fill the engine with lubricating oil. Refer to Procedure 007-037

Fill the engine with coolant. Refer to Procedure 008-018

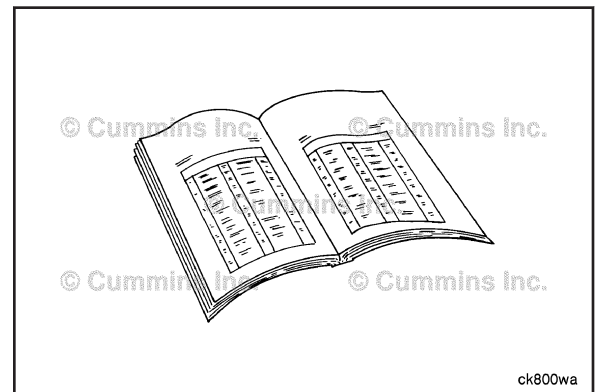

⚠ WARNING ⚠

Batteries can emit explosive gases. To reduce the possibility of personal injury, always ventilate the compartment before servicing the batteries. To reduce the possibility of arcing, remove the negative (-) battery cable first and attach the negative (-) battery cable last.

Connect the battery cables.

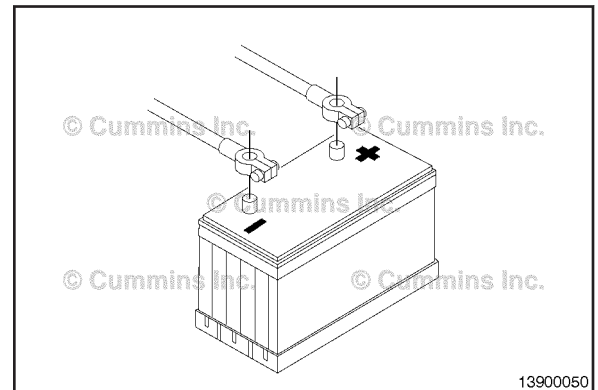

Operate the engine to normal operating temperature and check for leaks.

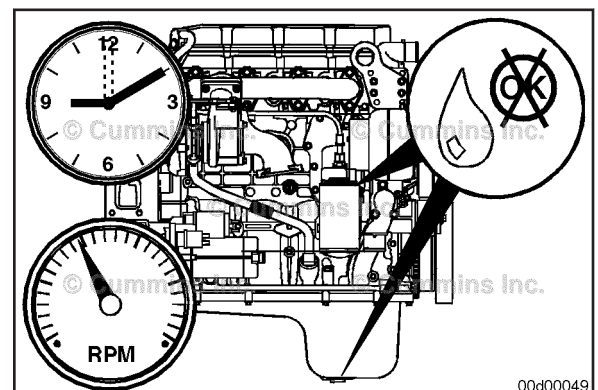

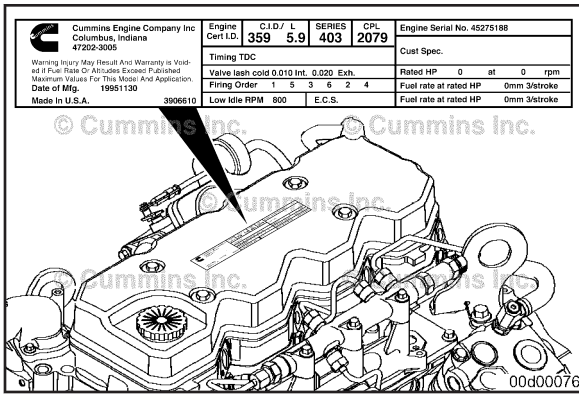

Engine Dataplate (001-057)

General Information

The engine data plate is typically located on the rocker lever cover, but may be located on the gear housing.

Two types of data plates are typically used:

- 1 Metal stamped data plate which is riveted in place
- 2 A printed plastic data plate label adhered in place.

If the data plate is damaged, missing or incorrect, contact your local Cummins Inc. Service location to obtain a new data plate.

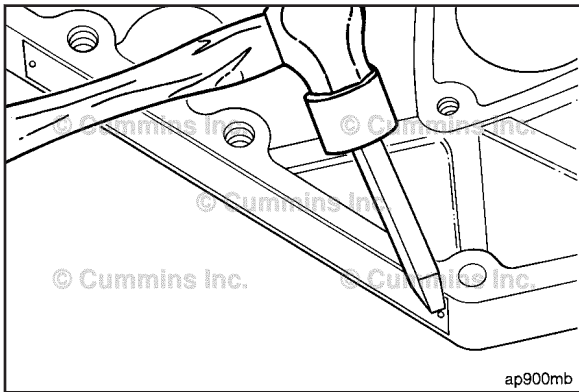

Remove

For metal stamped dataplates, remove the rivets securing the engine data plate.

NOTE: If the data plate is to be reused, care **must** be taken **not** damage the data on the plate.

Using a flat chisel and hammer, drive the chisel under the head of the rivet to pry the rivet out.

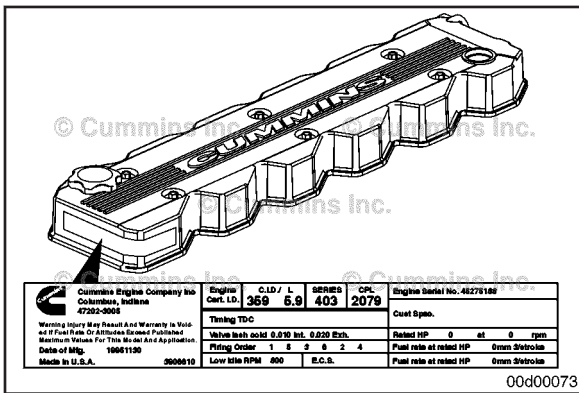

For printed plastic dataplates, using the sharp edge of a gasket scraper, peel up a corner of the data plate. Then pull on the corner to remove the data plate.

NOTE: In most instances the data plate will be damaged during removal, contact your local Cummins Inc. Service location to obtain a new data plate.

Clean and Inspect for Reuse

⚠ WARNING ⚠

When using solvents, acids, or alkaline materials for cleaning, follow the manufacturer's recommendations for use. Wear goggles and protective clothing to reduce the possibility of personal injury.

⚠ WARNING ⚠

Wear appropriate eye and face protection when using compressed air. Flying debris and dirt can cause personal injury.

Using solvent, clean the area where the data plate will be mounted.

Remove any left over adhesive from the printed plastic data plate. Use solvent with an abrasive pad, Part Number 3823258 or equivalent.

Dry with compressed air.

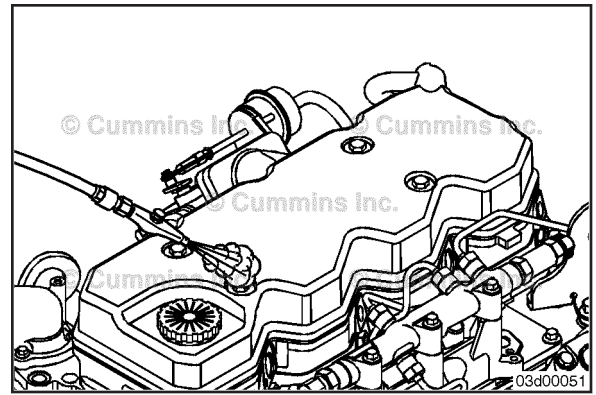

Install

⚠ CAUTION ⚠

When drilling holes for the data plate location, do not completely drill through the mounting location. Only drill deep enough to install the new blind rivets. Drill through will result in an oil leak.

For metal stamped dataplates, if attaching the data plate to a new component or if the old rivet locations are damaged, drill new holes and attach with new blind rivets.

NOTE: The data plate should be located in the same area as it was previously installed.

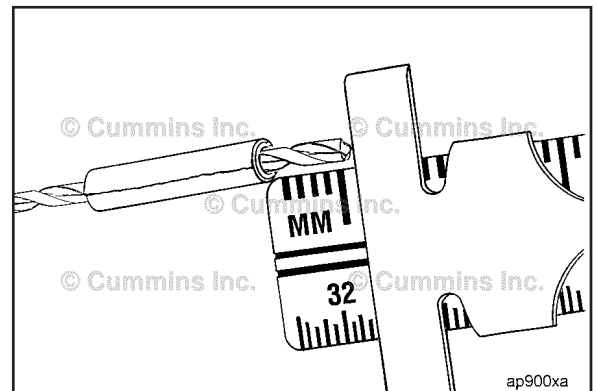

Install the data plate with new blind rivets. Drive the rivets until they contact the data plate.

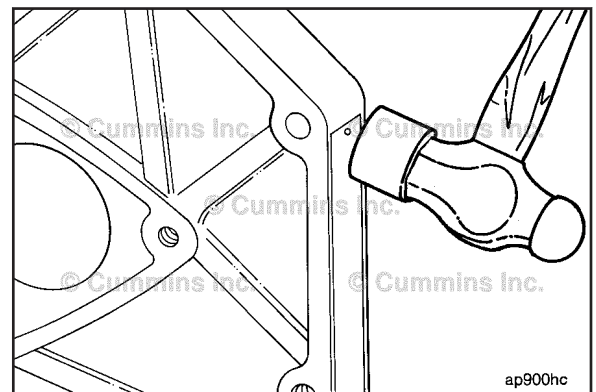

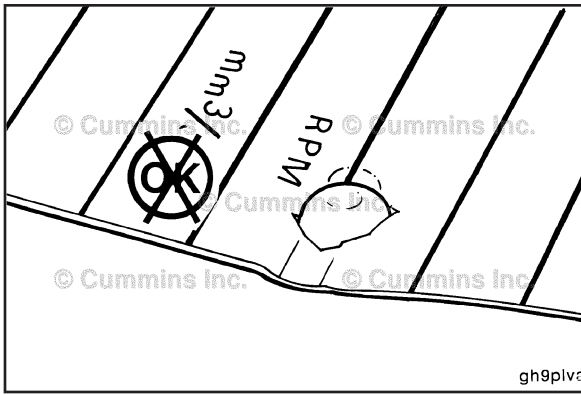

CAUTION
Do not drive the rivets too far, they will cut through and damage the data plate.

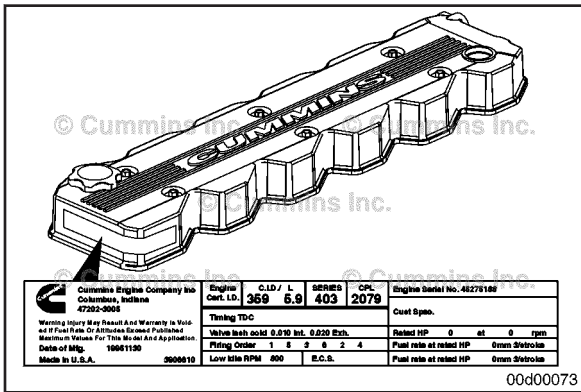

For printed plastic dataplates, peel the backing off of the new data plate. Apply the new data plate to the appropriate mounting surface. Rub the data plate with a clean rag to work out any air bubbles and to adhere the data plate to the mounting surface.

NOTE: The data plate should be located in the same area as it was previously installed.

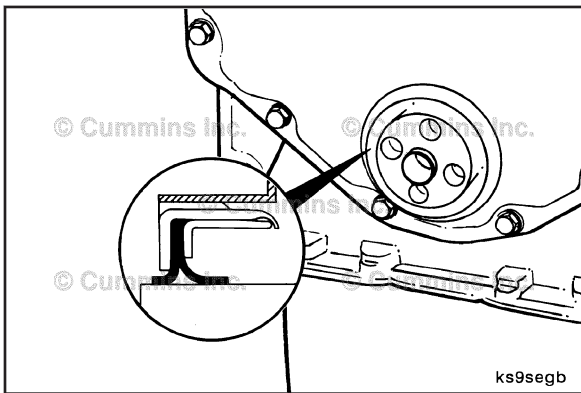

Crankshaft Wear Sleeve, Rear (001-067)

General Information

Some engines use a lip style rear crankshaft seal (shown) in which the rotating portion of the sealing occurs at the contact surface between the lip of the seal and the crankshaft.

Engines that commonly use a lip style rear crankshaft seal include:

Marine 5.9L engines.

Industrial and Automotive 4.5L and 6.7L engines.

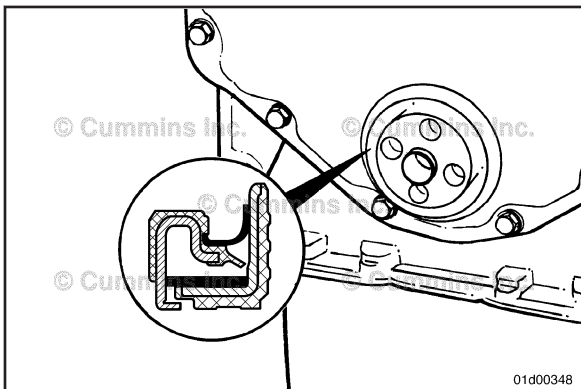

Unitized Seal

Other engines use a dual or non-lip style seal which utilize a built in wear sleeve and a concealed sealing lip. The inner and out diameter are press-fit onto the crankshaft and the flywheel housing respectively, requiring service tool, Part Number 3164660, to remove and install. The sealing point is internal to the seal.

Engines that commonly use a unitized rear crankshaft seal include:

Automotive 3.9L and 5.9L engines.

Only engines with a lip style front crankshaft seal can use a wear sleeve.

Preparatory steps

⚠ WARNING ⚠

Batteries can emit explosive gases. To reduce the possibility of personal injury, always ventilate the compartment before servicing the batteries. To reduce the possibility of arcing, remove the negative (-) battery cable first and attach the negative (-) battery cable last.

Disconnect the batteries.

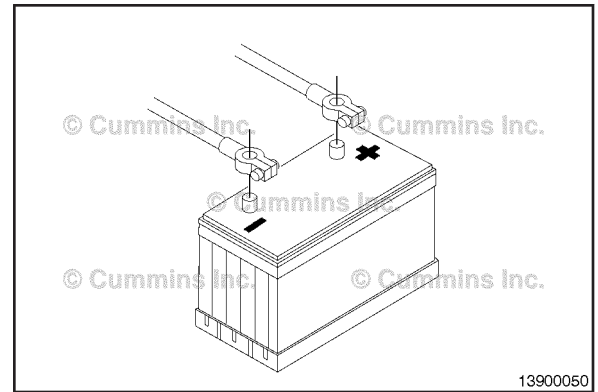

NOTE: Use a container that can hold at least 26 liters [27 US qt] of lubricating oil.

If equipped with a wet flywheel housing, drain the oil from the flywheel housing by removing the plug in the bottom of the flywheel housing.

Remove the starting motor. Refer to Procedure Procedure 013-020

Remove the transmission and all related components (if equipped). Refer to the OEM instructions.

Remove the flywheel/flexplate assembly. Refer to Procedure Procedure 016-005 or Refer to Procedure Procedure 016-004

For rear gear train engines, remove the rear crankshaft seal. Refer to Procedure Procedure 001-024

For some engines, it may be necessary to remove the crankcase breather tube. Refer to Procedure Procedure 003-018

Remove any OEM attached components (mufflers, shift mechanisms, air filters, etc.) to the flywheel housing. Refer to the OEM instructions.

For front gear train engines, remove the flywheel housing. Refer to Procedure Procedure 016-006

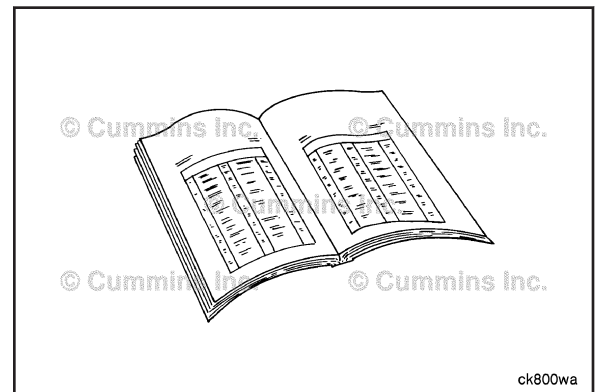

⚠ WARNING ⚠

Batteries can emit explosive gases. To reduce the possibility of personal injury, always ventilate the compartment before servicing the batteries. To reduce the possibility of arcing, remove the negative (-) battery cable first and attach the negative (-) battery cable last.

Disconnect the batteries.

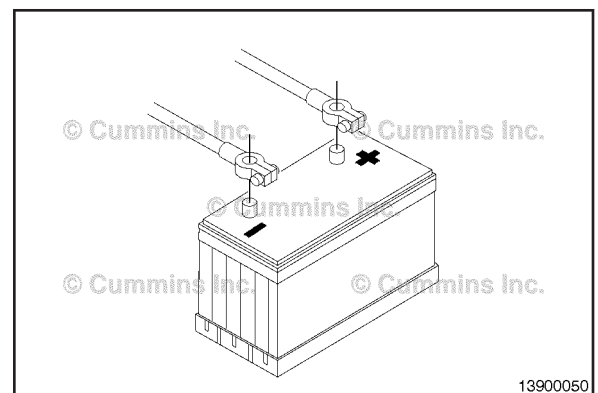

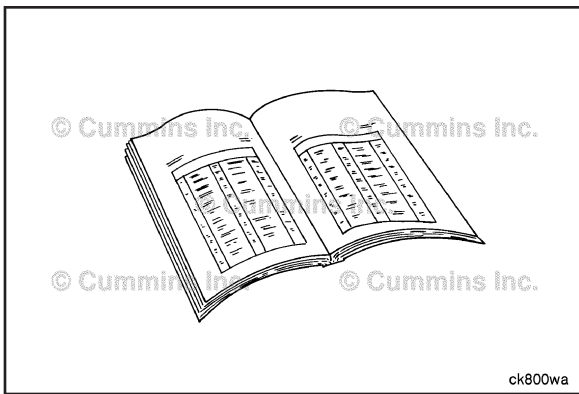

Drain the coolant. Refer to Procedure Procedure 008-018
Remove the starting motor. Refer to Procedure Procedure 013-020



Remove the turbocharger. Refer to Procedure Procedure 010-033

Remove or loosen the aftercooler mounting capscrews and remove the aftercooler air inlet tube. Refer to Procedure Procedure 010-005

Remove the gear drive unit. Refer to Procedure Procedure 016-009

Remove the flywheel/flexplate assembly. Refer to Procedure Procedure 016-005 or Refer to Procedure Procedure 016-004

Remove the flywheel housing. Refer to Procedure Procedure 016-006

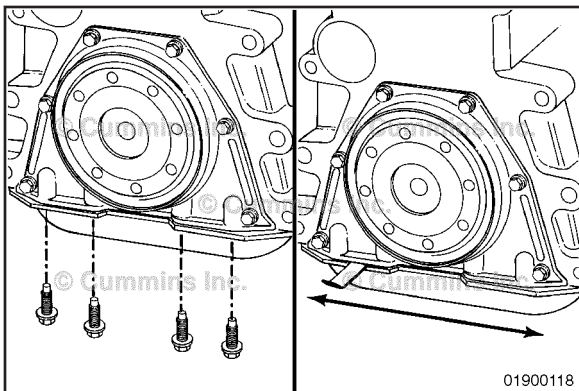

Remove

Remove the four oil pan mounting capscrews that secure the oil pan to the rear cover.



⚠CAUTION⚠

Use extreme care when releasing the oil pan gasket from the rear cover to prevent damage to the gasket. If the gasket is damaged, the oil pan must be removed and the gasket replaced. Refer to Refer to Procedure Procedure 007-025

Insert the feeler gauge or shim stock between the rear cover and the oil pan gasket. Move the feeler gauge back and forth to release the gasket from the rear cover.

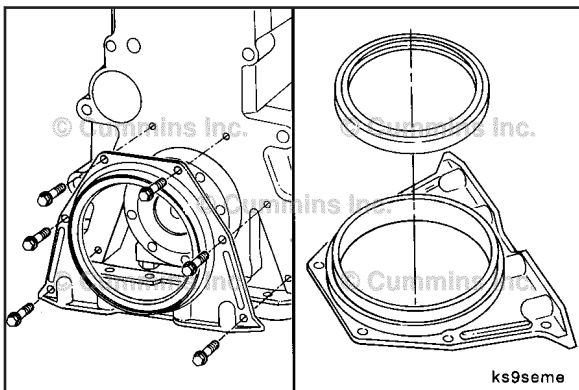

Remove the capscrews from the rear cover.

Remove the cover from the crankshaft flange.

Support the rear seal carrier on a flat work surface with wooden blocks, and using a suitable punch and hammer, drive the old seal out of the rear seal carrier.

⚠ CAUTION ⚠

Do not nick or gouge the crankshaft with the chisel. If the crankshaft is damaged, it must be replaced.

NOTE: For rear gear train engines, if a wear sleeve has previously been installed, the flywheel housing **must** be removed to remove the wear sleeve. After removing the wear sleeve, reinstall the flywheel housing. Refer to Procedure Procedure 016-006

If a wear sleeve has previously been installed, use a dull chisel that is **only** as wide as the wear sleeve.

Make one or two soft blows with a hammer to make chisel marks across the wear sleeve. This will expand the wear sleeve, allowing the sleeve to be removed.

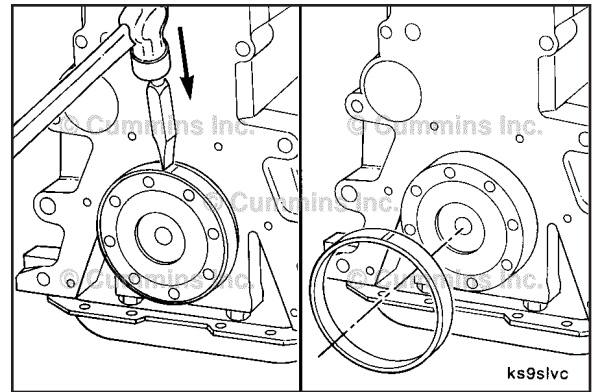

Clean and Inspect for Reuse

⚠ WARNING ⚠

When using solvents, acids, or alkaline materials for cleaning, follow the manufacturer's recommendations for use. Wear goggles and protective clothing to avoid personal injury.

⚠ WARNING ⚠

Compressed air used for cleaning should not exceed 207 kPa [30 psi]. Wear appropriate eye and face protection when using compressed air. Flying debris and dirt can cause bodily injury.

For front gear train engines, clean the gasket surface of the cylinder block and rear seal carrier.

Dry these areas with compressed air.

If equipped, inspect the rear seal carrier for cracks or other damage. Replace the rear seal carrier if any damage is found.

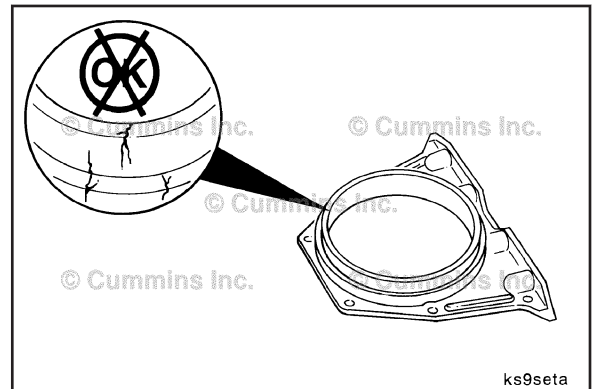
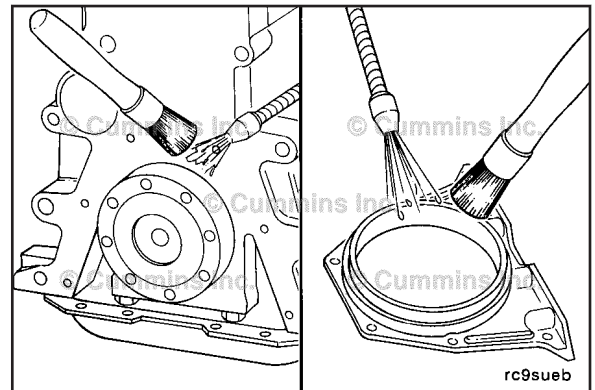

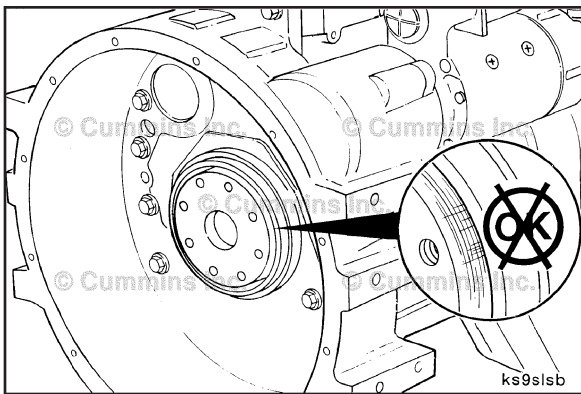

For rear gear train engines, clean the flywheel housing bore of any seal residue.



Inspect the flywheel housing bore for nicks or burrs. Use an abrasive pad, Part Number 3823258 or equivalent, to remove any minor damage.

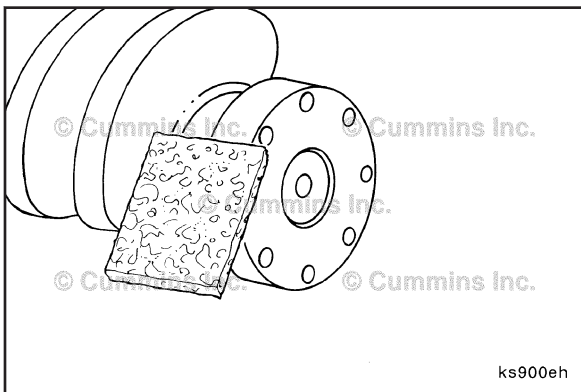

Use a fine crocus cloth to remove any rust or other deposits from the crankshaft flange.



Use a clean cloth and solvent to clean the crankshaft flange.

Inspect the crankshaft flange for nicks or burrs. Use an abrasive pad, Part Number 3823258 or equivalent, to remove any minor damage.

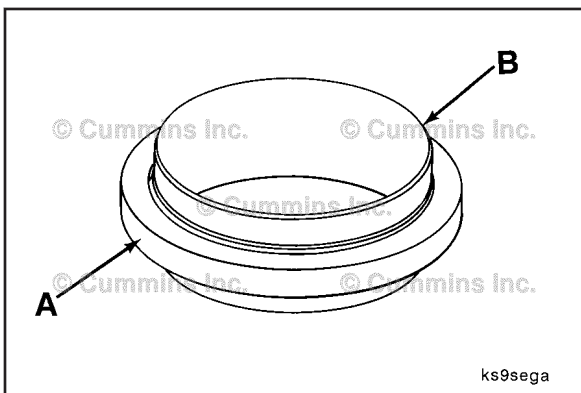

Install

NOTE: For engines equipped with a wet flywheel housing, make sure to replace the rear crankshaft seal with the correct rear seal. Rear crankshaft seals for a wet and dry flywheel housings may **not** be the same.

NOTE: The replacement oversize seal may appear different than the standard size seal.

⚠CAUTION⚠

The new rear crankshaft seal should not be removed from the crankshaft rear seal wear sleeve. Damage to the sealing lips may occur when reinstalling the seal onto the wear sleeve.

The new oversize seal and wear sleeve comes preassembled and will be installed on the crankshaft as an assembly.

- Crankshaft oil seal
- Wear sleeve.

Service Tip: If the oil pan gasket was damaged during removal of the rear seal carrier, remove the damaged gasket and:



- 1 If previously equipped with a paper oil pan gasket, use the old gasket as a pattern and cut a section of a new gasket to the same size. Use a light coat of sealant, Part Number 3164067, to hold the gasket in place
- 2 If previously equipped with a sealant only oil pan gasket, apply a bead of sealant, Part Number 3164070, to the oil pan flange
- 3 If previously equipped with a suspended oil pan, the oil pan must be removed and a new gasket installed. Refer to Procedure Procedure 007-025

NOTE: The rear seal carrier **must** be installed within 10 minutes of applying the sealant.

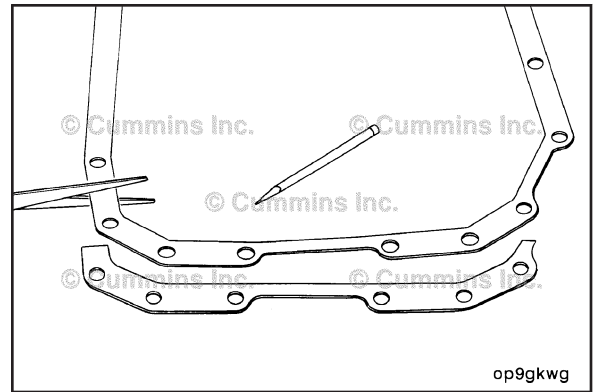

NOTE: If the oil pan is installed, it may be necessary to loosen additional oil pan capscrews to allow clearance for rear seal carrier and gasket clearance.



NOTE: It may be necessary to trim the rear seal carrier gasket so that it is even with the oil pan mounting surface. Also, apply a thin bead of sealant, part number 3164067, at this joint prior to installing the rear seal carrier. The rear seal carrier **must** be installed within 10 minutes of applying the sealant.

Install the rear seal carrier, mounting capscrews and gasket.

Loosely tighten the rear seal carrier mounting capscrews at this time.

NOTE: The seal installation will properly align the rear seal carrier.

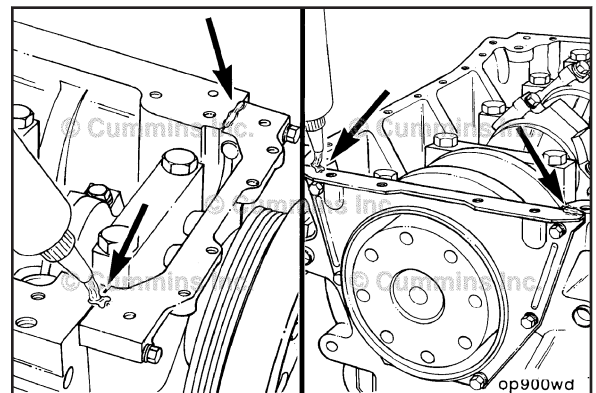

To aid in installation, the lubricating oil seal requires the application of a mild soap on the outside diameter of the seal case.

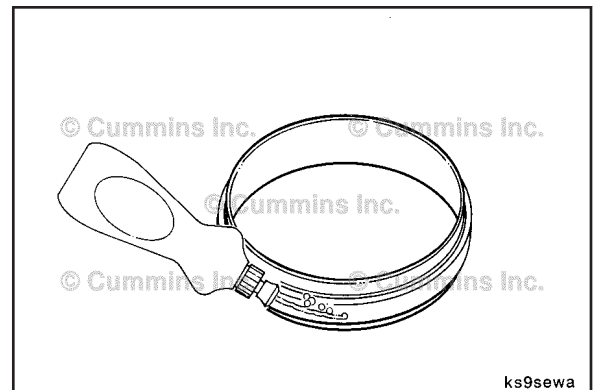

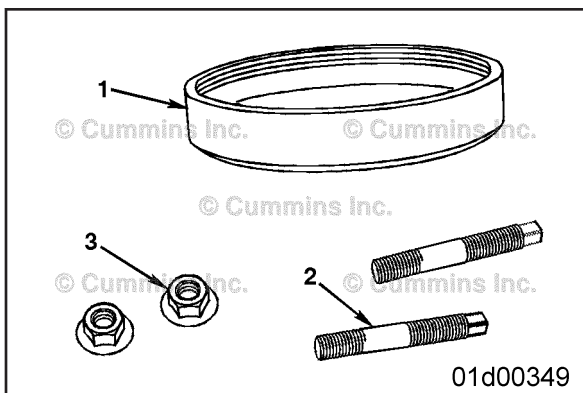

Use service tool, Part Number 3824078, to install the crankshaft seal/wear sleeve assembly.

Reference Number	Part Number	Description
1	3163734	Plate
2	3163628	Stud
3	3163741	Hex Nut

Install two (2) threaded studs into the crankshaft capscrew holes.

Apply a small amount of clean 15W-40 engine oil to the crankshaft, threaded studs, and inside of the crankshaft rear seal/wear sleeve installation tool.

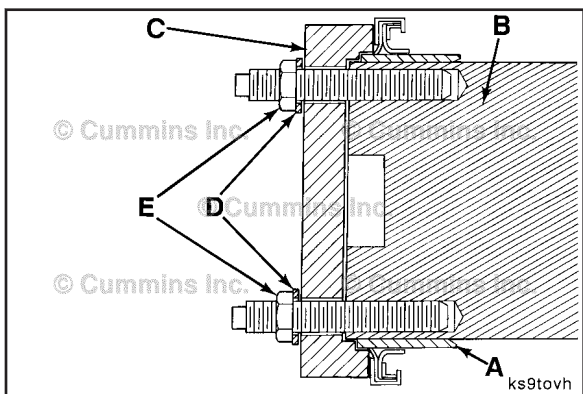

Position the chamfered end of the wear sleeve (A) onto the end of the crankshaft (B).



Position the counterbore end of installation tool (C) over threaded studs and align with wear sleeve, perpendicular to the end of the crankshaft.

Install the washers (D) and nuts (E) onto the threaded studs.

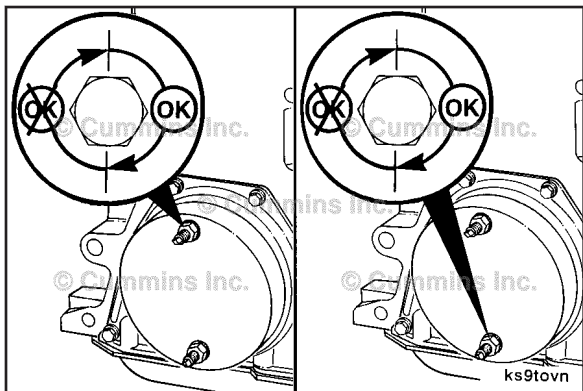

Alternately tighten the nuts 1/2 of a turn until the installation tool contacts the end of the crankshaft.



Do **not** exceed 1/2 of a turn of each nut to prevent wear sleeve binding and irregular stretch.

Torque Value: 20 N•m [15 ft-lb]

Remove the installation tool and threaded studs.

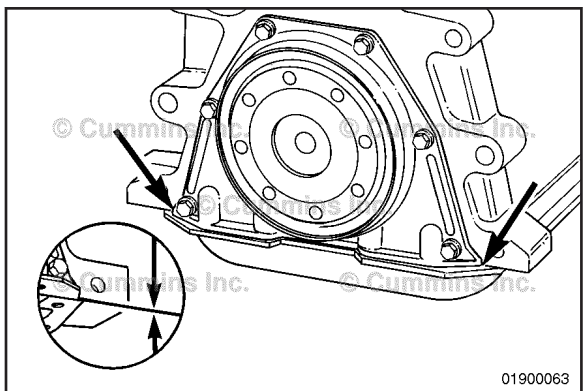

⚠ CAUTION ⚠

Do not push or force the cover in any direction. This may cause an irregular seal lip position after seal installation. An engine oil leak will result.

Align the rear cover even with both sides of the oil pan rail on the cylinder block.

Tighten the rear cover capscrews.

Torque Value: 10 N•m [89 in-lb]

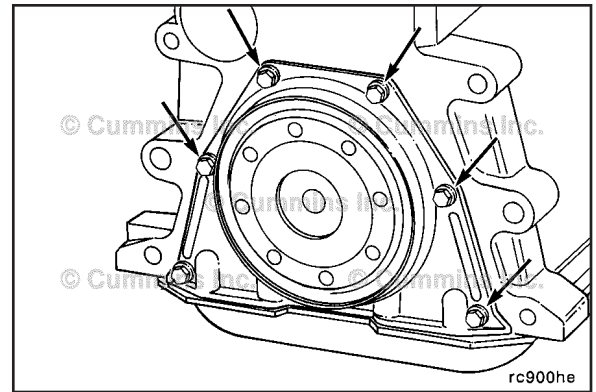

Install the four rear oil pan mounting capscrews into the pan.

Torque Value: 24 N•m [18 ft-lb]

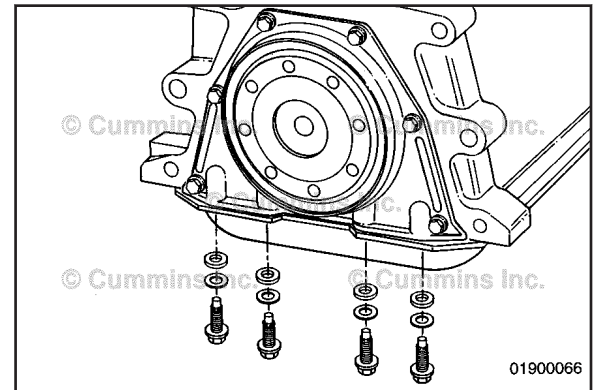

Finishing steps

If previously removed, install the crankcase breather tube. Refer to Procedure Procedure 003-018

Install the flywheel/flexplate assembly. Refer to Procedure Procedure 016-005 or Refer to Procedure Procedure 016-004

Install the starting motor. Refer to Procedure Procedure 013-020

Install the transmission and all related components (if equipped). Refer to the OEM instructions.

If equipped with a wet flywheel housing, fill the flywheel housing with oil. Refer to OEM instructions.

If previously removed, attach any OEM attached components (mufflers, shift mechanisms, air filters, etc.) to the flywheel housing. Refer to the OEM instructions.

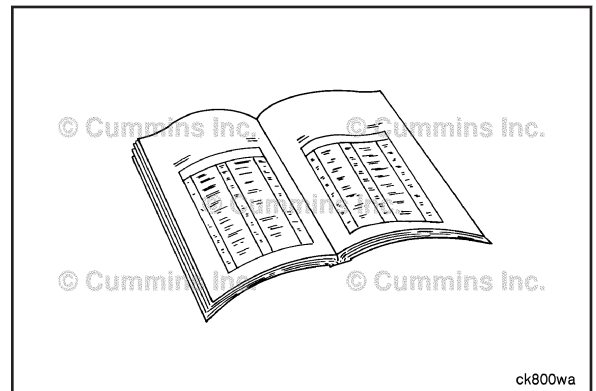

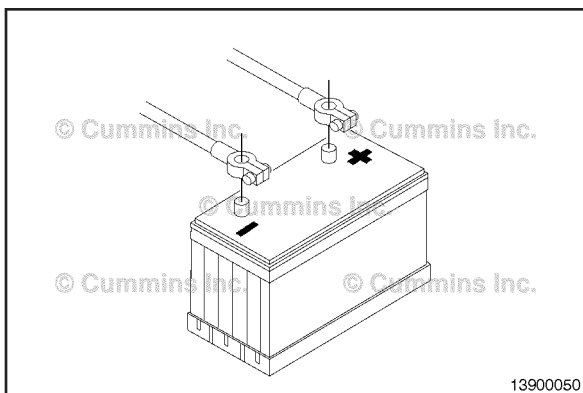

▲ WARNING ▲

Batteries can emit explosive gases. To reduce the possibility of personal injury, always ventilate the compartment before servicing the batteries. To reduce the possibility of arcing, remove the negative (-) battery cable first and attach the negative (-) battery cable last.

Connect the batteries.

Operate engine and check for leaks.

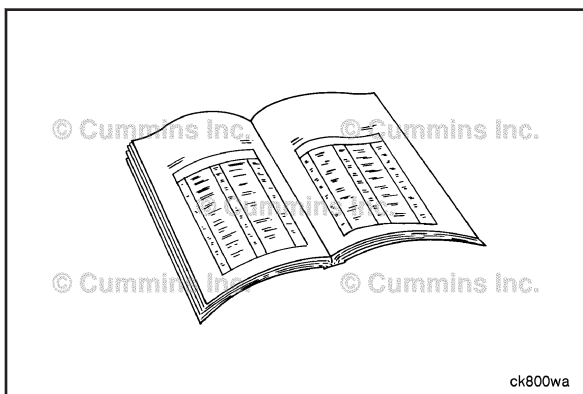

Install the flywheel housing. Refer to Procedure Procedure 016-006



Install the flywheel/flexplate assembly. Refer to Procedure Procedure 016-005 or Refer to Procedure Procedure 016-004

Install the gear drive unit. Refer to Procedure Procedure 016-009

Install the starting motor. Refer to Procedure Procedure 013-020

Install the aftercooler air inlet tube and tighten the aftercooler mounting capscrews. Refer to Procedure Procedure 010-005

Install the turbocharger. Refer to Procedure Procedure 010-033

Fill the coolant. Refer to Procedure Procedure 008-018

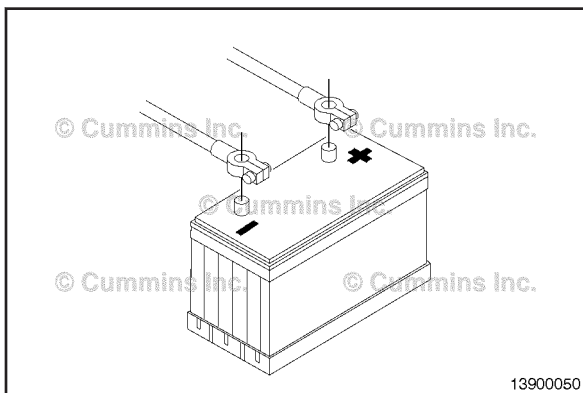

▲ WARNING ▲

Batteries can emit explosive gases. To reduce the possibility of personal injury, always ventilate the compartment before servicing the batteries. To reduce the possibility of arcing, remove the negative (-) battery cable first and attach the negative (-) battery cable last.

Connect the batteries.

Operate engine and check for leaks.

Crankshaft Speed Indicator Ring (001-071)

General Information

For 3.9 L and 5.9 L engines, the crankshaft speed indicator ring is held in place by the same capscrews as the vibration damper. For 4.5 L and 6.7 L engines, with a rear gear train, the crankshaft speed indicator ring is a part of the vibration damper assembly and should **not** be removed from the vibration damper. Also, some 4 cylinder engines do **not** use a vibration damper and only mount the crankshaft speed indicator ring to the nose of the crankshaft.

Preparatory Steps

⚠ WARNING ⚠

Batteries can emit explosive gases. To reduce the possibility of personal injury, always ventilate the compartment before servicing the batteries. To reduce the possibility of arcing, remove the negative (-) battery cable first and attach the negative (-) battery cable last.

Disconnect the batteries.

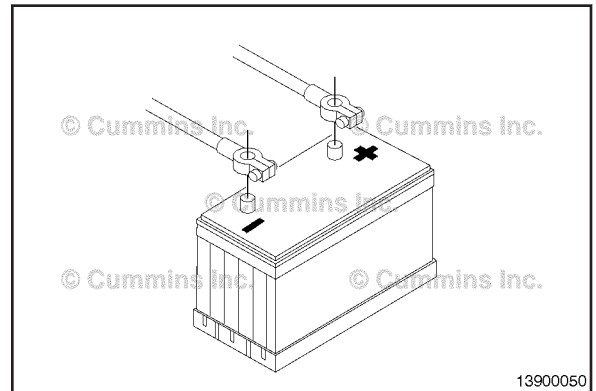

Remove the drive belt. Refer to Procedure Procedure 008-002

Remove the vibration damper and crankshaft speed indicator ring. If equipped with a viscous damper, Refer to Procedure Procedure 001-052. If equipped with a rubber damper, Refer to Procedure Procedure 001-051

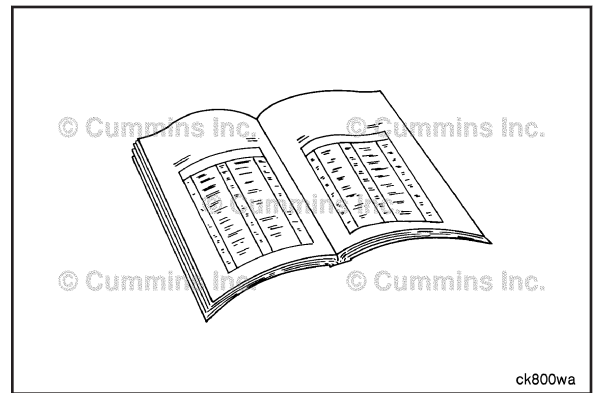

Remove

If the engine is **not** equipped with a vibration damper, remove the six capscrews that hold the crankshaft speed indicator ring/pulley to the nose of the crankshaft.

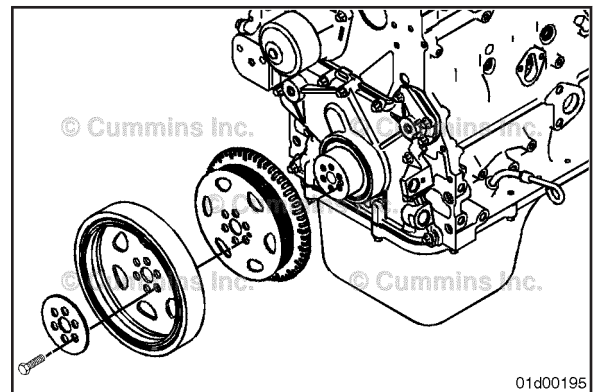

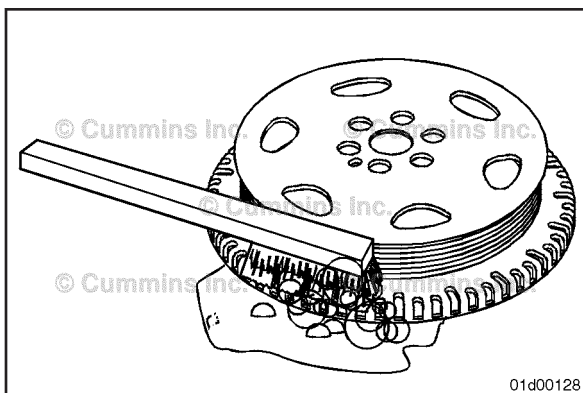

Clean and Inspect for Reuse

⚠ WARNING ⚠

Compressed air used for cleaning should not exceed 207 kPa [30 psi]. Wear protective clothing, goggles/shield, and gloves to reduce the possibility of personal injury.

Using soapy water, clean any oil from the crankshaft speed indicator ring.

Dry the speed indicator ring with compressed air.

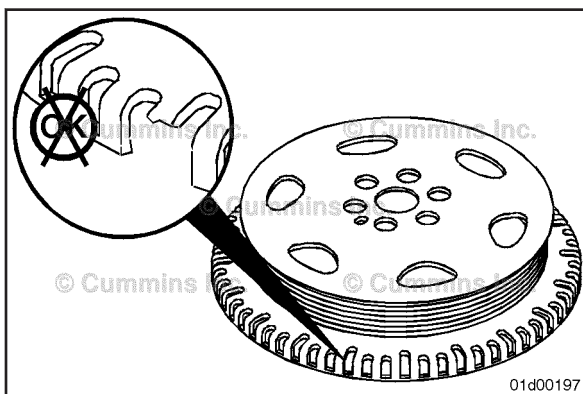

Inspect the speed indicator ring for missing teeth, cracks, or damaged surfaces.

If any damage is found, the speed indicator ring **must** be replaced.

NOTE: For 4.5 L and 6.7 L engines, with a rear gear train, if the crankshaft speed indicator ring is found damaged, the whole vibration damper assembly **must** be replaced.

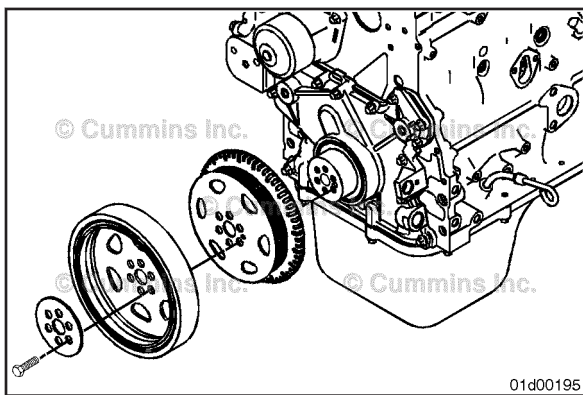

Install

If the engine is **not** equipped with a vibration damper, install the six capscrews that hold the crankshaft speed indicator ring/pulley to the nose of the crankshaft.

Tighten crankshaft speed indicator ring/pulley capscrews.

Torque Value:

Step 1 50 N•m [37 ft-lb]
Step 2 Rotate 90 degrees

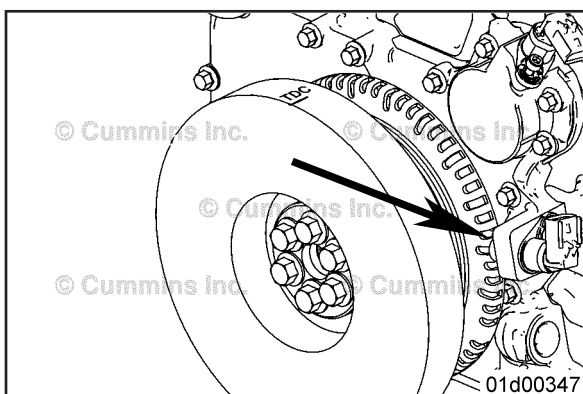

Measure

Crankshaft Speed/Position Sensor Air Gap Check.

With the vibration damper and crankshaft speed indicator ring installed, measure the crankshaft speed/position sensor air gap between the crankshaft speed/position sensor and the crankshaft speed indicator ring with feeler gauge.

Crankshaft Speed/Position Sensor Air Gap

mm		in
0.8	MIN	0.032
1.5	MAX	0.060

If the air gap is **not** within specification, remove and inspect the crankshaft speed/position sensor for damage.

Finishing Steps

Install the vibration damper and crankshaft speed indicator ring. If equipped with a viscous damper, Refer to Procedure Procedure 001-052. If equipped with a rubber damper, Refer to Procedure Procedure 001-051

Install the drive belt. Refer to Procedure Procedure 008-002

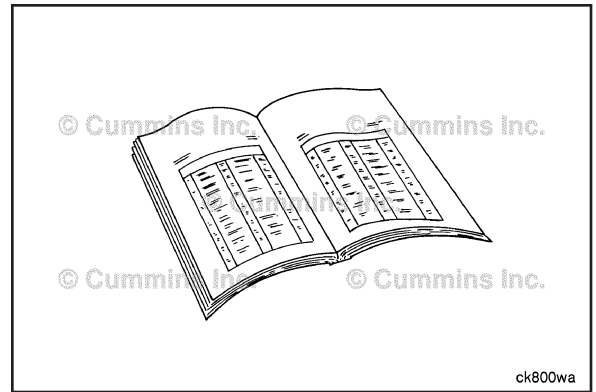

ck800wa

⚠ WARNING ⚠

Batteries can emit explosive gases. To reduce the possibility of personal injury, always ventilate the compartment before servicing the batteries. To reduce the possibility of arcing, remove the negative (-) battery cable first and attach the negative (-) battery cable last.

Connect the batteries.

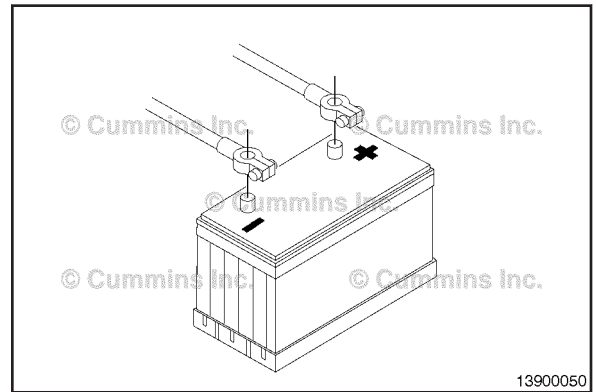

13900050

Block Stiffener Plate (001-089)

Preparatory Steps

⚠ WARNING ⚠

Batteries can emit explosive gases. To reduce the possibility of personal injury, always ventilate the compartment before servicing the batteries. To reduce the possibility of arcing, remove the negative (-) battery cable first and attach the negative (-) battery cable last.

Disconnect the batteries.

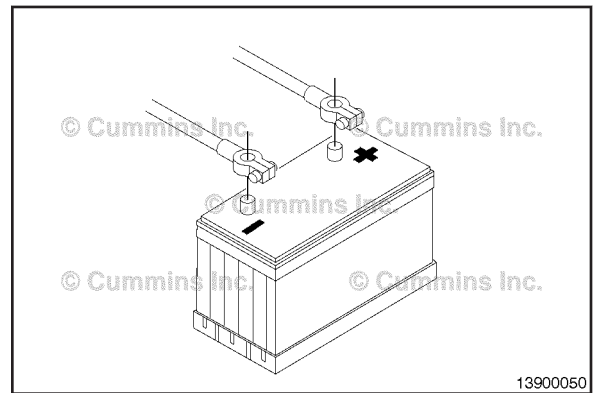

13900050

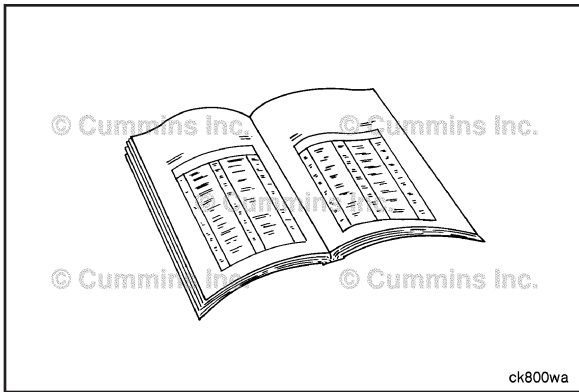

⚠ WARNING ⚠

Some state and federal agencies have determined that used engine oil can be carcinogenic and cause reproductive toxicity. Avoid inhalation of vapors, ingestion, and prolonged contact with used engine oil.



⚠ WARNING ⚠

To reduce the possibility of personal injury, avoid direct contact of hot oil with your skin.

Drain the lubricating oil. Refer to Procedure Procedure 007-037

Remove the lubricating oil pan. Refer to Procedure Procedure 007-025

Remove the lubricating oil suction tube. Refer to Procedure Procedure 007-035

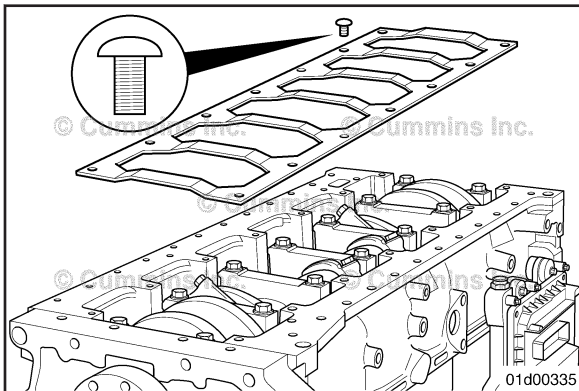

Remove

NOTE: For some oil pan/oil suction tube configurations, the block stiffener plate cap screw closest to the lubricating oil suction tube may be different than the rest. If equipped, note the cap screws location for installation. The low profile cap screw ensures in some applications that there is sufficient clearance between the oil suction tube and the block stiffener mounting cap screw.

Remove the cap screws and block stiffener plate.

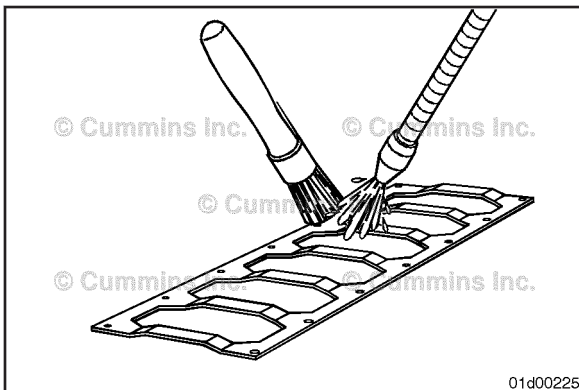

Clean and Inspect for Reuse

⚠ WARNING ⚠

When using solvents, acids, or alkaline materials for cleaning, follow the manufacturer's recommendations for use. Wear goggles and protective clothing to reduce the possibility of personal injury.

⚠ WARNING ⚠

Wear appropriate eye and face protection when using compressed air. Flying debris and dirt can cause personal injury.

Clean the block stiffener plate with solvent. Dry with compressed air.

Check the block stiffener plate for cracks. Replace if damage is present.

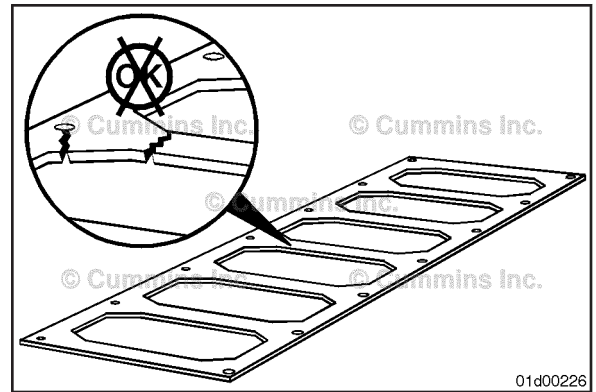

Install

NOTE: The block stiffener plate **must** be installed so that the center ribs are bent away from the block, to ensure proper clearance from the block main caps.

NOTE: Some 6 cylinder engines use a 4 cylinder block stiffener plate. When installing the block stiffener plate, make sure it is centered on the block.

NOTE: For some oil pan/oil suction tube configurations, one of the block stiffener mounting capscrews may be different than the rest. This capscrew, with a lower head profile, should be installed in the opening adjacent to the oil suction tube mounting location. The low profile capscrew ensures in some applications that there is sufficient clearance between the oil suction tube and the block stiffener mounting capscrew.

Install the block stiffener plate so that the exterior portion of the block stiffener plate with the recess is next to the oil suction tube mounting location at the front of the engine.

Install the block stiffener plate mounting capscrews.

Torque Value:

Block Stiffener Plate Capscrews
Step 1 43 N•m [32 ft-lb]

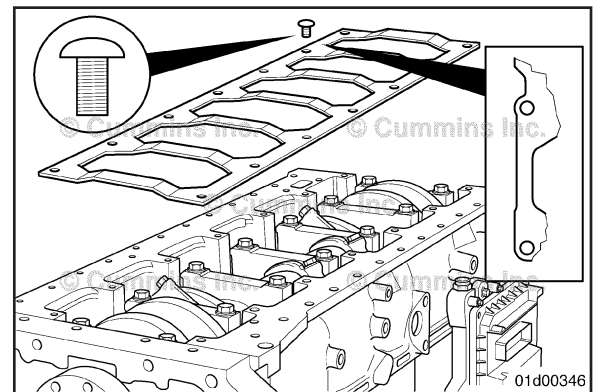

Finishing Steps

Install the lubricating oil suction tube. Refer to Procedure Procedure 007-035

Install the lubricating oil pan. Refer to Procedure Procedure 007-025

Fill the engine with clean lubricating oil. Refer to Procedure Procedure 007-037

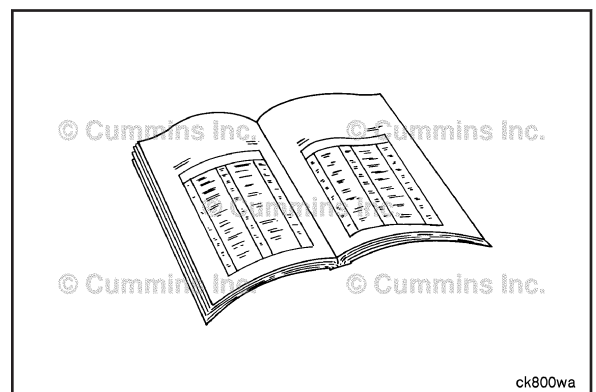

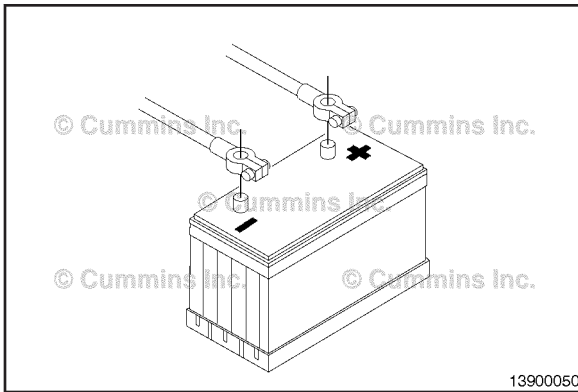

▲ WARNING ▲

Batteries can emit explosive gases. To reduce the possibility of personal injury, always ventilate the compartment before servicing the batteries. To reduce the possibility of arcing, remove the negative (-) battery cable first and attach the negative (-) battery cable last.

Connect the batteries.

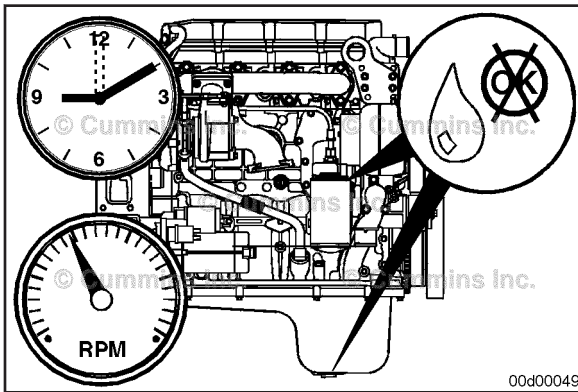

Operate the engine and check for leaks.

ECM Mounting Plate (001-103) General Information

The ECM mounting plate is located between the ECM and the cylinder block, and is made of either aluminum or nylon. An aluminum ECM mounting plate has fins on the engine side, used to cool the ECM, and a steel yolk for attaching to the cylinder block.

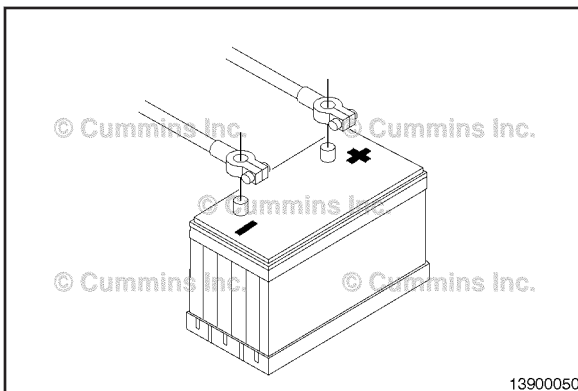

Preparatory Steps

▲ WARNING ▲

Batteries can emit explosive gases. To reduce the possibility of personal injury, always ventilate the compartment before servicing the batteries. To reduce the possibility of arcing, remove the negative (-) battery cable first and attach the negative (-) battery cable last.

Disconnect the batteries.

Remove the ECM from the ECM mounting plate. Refer to Procedure 019-031 in the corresponding electronics Troubleshooting and Repair Manual.

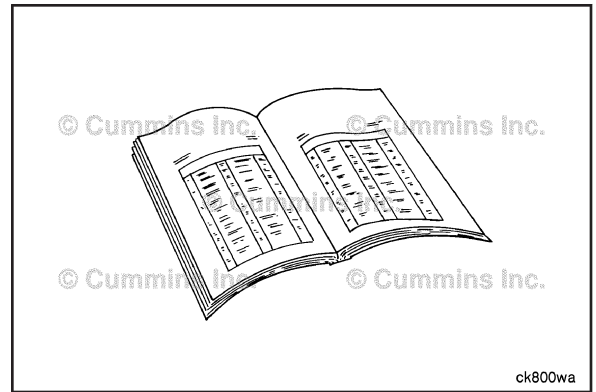

Remove

Remove the three cap screws holding the ECM mounting plate to the cylinder block.

NOTE: Do **not** lose the vibration isolators while removing the cap screws.

NOTE: On engines with an aluminum ECM mounting plate, the steel yolk and ECM mounting plate are removed as an assembly.

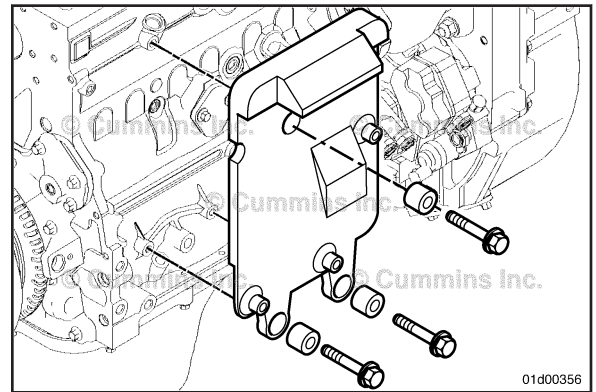

Disassemble

For an aluminum ECM mounting plate, remove the three cap screws holding the ECM mounting plate on the steel yolk.

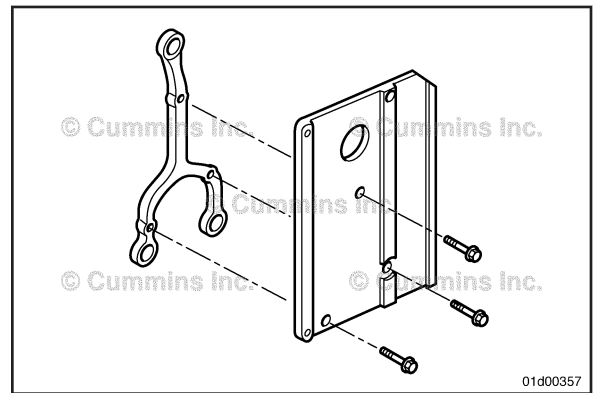

Clean and Inspect for Reuse

For an aluminum ECM mounting plate, clear debris from cooling fins and yoke for maximum efficiency.

Inspect the ECM mounting plate for cracks. Replace if any damage is found.

Remove all grease and paint from the contact surfaces of the ground strap.

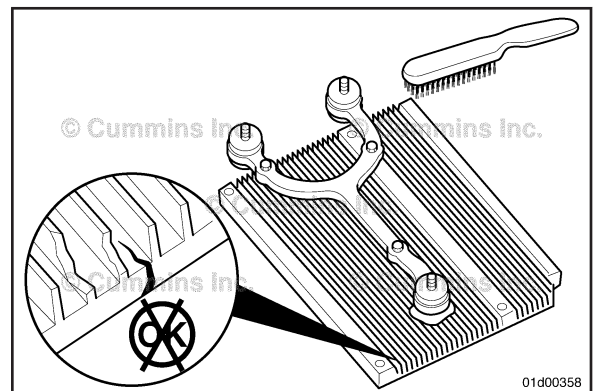

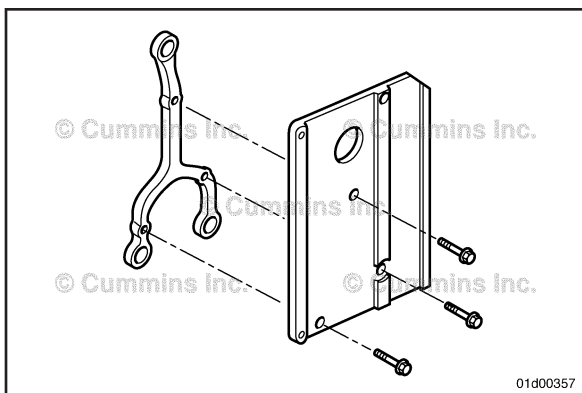

Assemble

For an aluminum ECM mounting plate, install the aluminum ECM mounting plate onto the steel yolk.



Install the three cap screws attaching the aluminum ECM mounting plate to the steel yolk.

Torque Value: 24 N•m [18 ft-lb]

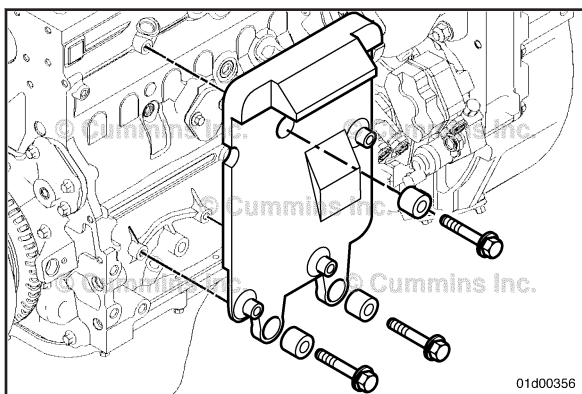

Install

NOTE: Be sure that the vibration isolators are installed in the ECM mounting plate prior to installing the capscrews.



Install the three mounting cap screws that secure the ECM mounting plate to the cylinder block.

Torque Value: 24 N•m [18 ft-lb]

NOTE: For engines with an aluminum ECM mounting plate, the ECM mounting plate and the steel yolk are installed as an assembly onto the cylinder block.

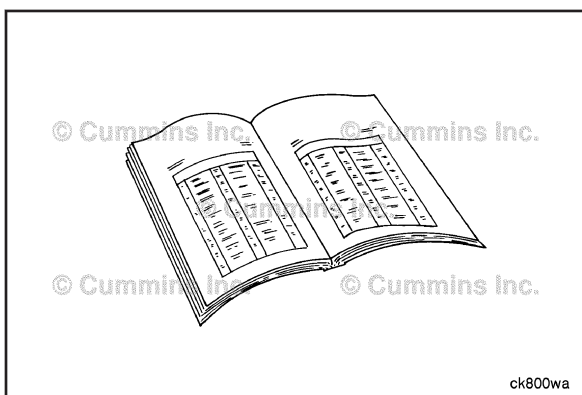

Finishing Steps

Install the ground strap between the ECM and cylinder block.



Torque Value:

For Engine Side of Ground Strap

Step 1 24 N•m [18 ft-lb]



NOTE: The ground strap **must** make contact with a clean surface on the engine and ECM for proper operation.

Install the ECM on the ECM mounting plate. Refer to Procedure 019-031 in the corresponding electronics Troubleshooting and Repair Manual.

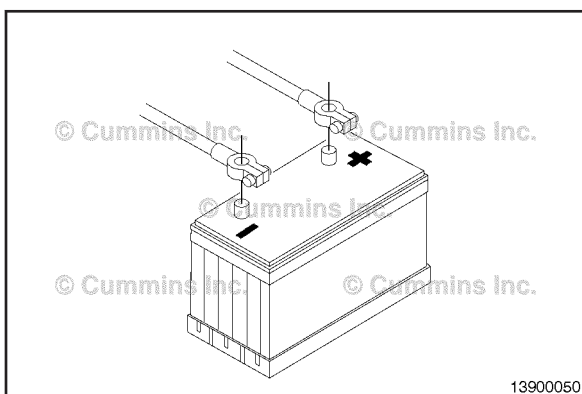

⚠ WARNING ⚠

Batteries can emit explosive gases. To reduce the possibility of personal injury, always ventilate the compartment before servicing the batteries. To reduce the possibility of arcing, remove the negative (-) battery cable first and attach the negative (-) battery cable last.

Connect the batteries.

Operate engine and check for proper operation.

Section 2 - Cylinder Head - Group 02

Section Contents



	Page
Crosshead	2-4
Clean and Inspect for Reuse.....	2-4
Finishing Steps.....	2-5
Install.....	2-5
Preparatory Steps.....	2-4
Remove.....	2-4
Cylinder Head	2-6
Assemble.....	2-26
Clean and Inspect for Reuse.....	2-16
Disassemble.....	2-13
Finishing Steps.....	2-34
Initial Check.....	2-10
Install.....	2-31
Measure.....	2-30
Preparatory Steps.....	2-6
Pressure Test.....	2-23
Remove.....	2-10
Test.....	2-6
Cylinder Head Gasket	2-45
Clean and Inspect for Reuse.....	2-46
Finishing Steps.....	2-50
General Information.....	2-45
Install.....	2-49
Measure.....	2-46
Preparatory Steps.....	2-45
Remove.....	2-46
Mounting Bracket, Lubricating Oil and Fuel Filter	2-51
Assemble.....	2-53
Disassemble.....	2-52
Finishing Steps.....	2-54
Inspect for Reuse.....	2-52
Install.....	2-53
Preparatory Steps.....	2-51
Remove.....	2-52
Service Tools	2-1
Cylinder Head.....	2-1
Valve Guide Seal, Cylinder Head	2-37
Clean and Inspect for Reuse.....	2-41
Finishing Steps.....	2-45
General Information.....	2-37
Install.....	2-42
Preparatory Steps.....	2-37
Remove.....	2-38



This Page Left Intentionally Blank

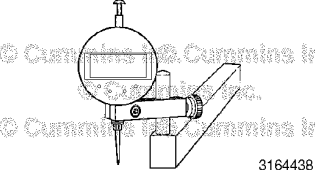
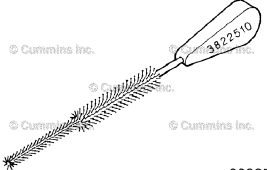
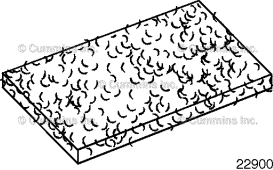

Service Tools

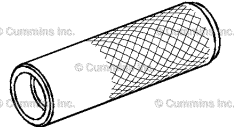
Cylinder Head

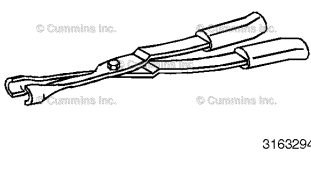
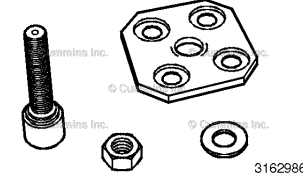
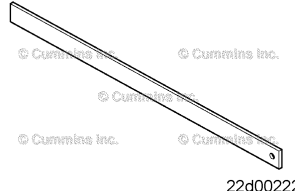
The following special tools are recommended to perform procedures in this section. The use of these tools is shown in the appropriate procedure. These tools can be purchased from a local Cummins® Authorized Repair Location.

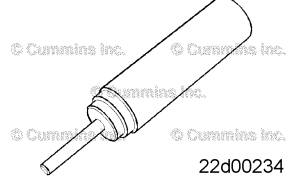
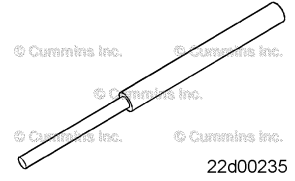
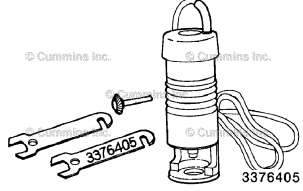
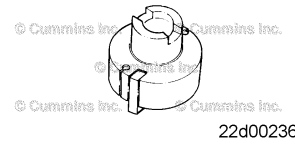
Tool No.	Tool Description	Tool Illustration
3375182	<p align="center">Valve Spring Tester</p> <p>Used to check spring tension.</p>	 <p>3375182</p>
3164438	<p align="center">Depth Gauge Assembly</p> <p>Used to measure liner protrusion, injector protrusion, cylinder block counterbore depths, and valve intrusion and/or protrusion. Equipped with electronic digital indicator.</p>	 <p>3164438</p>
3822510	<p align="center">Injector Bore Brush</p> <p>Used to clean the injector bore in the cylinder head.</p>	 <p>3822510</p>
3823258	<p align="center">Abrasive Pad</p> <p>Used to clean carbon from the upper liner bores, for removing rust and corrosion, and for scuffing surfaces.</p>	 <p>22900039</p>
3164057	<p align="center">Capscrew Length Gauge</p> <p>Used to measure the length of the cylinder head capscrews.</p>	 <p>22d00085</p>
3164055	<p align="center">Valve Stem Seal Installer</p> <p>Used to install the valve stem seal.</p>	 <p>22d00088</p>

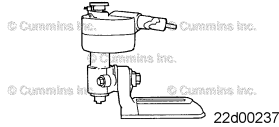
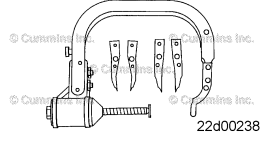
Tool No.	Tool Description	Tool Illustration
3163293	<p align="center">Boot Plier</p> <p>Used to remove the valve seal.</p>	
3164329	<p align="center">Valve Spring Compressor</p> <p>Used to compress the valve springs.</p>	
4918219	<p align="center">Precision Straightedge</p> <p>Used to check cylinder head combustion deck for flatness.</p>	
3165170	<p align="center">Valve Seat Extractor Collet</p> <p>Used with slide hammer, Part Number 3376617. Slide Hammer sold separately.</p>	
3165171	<p align="center">Valve Seat Installer</p> <p>Used for installing valve seats.</p>	
3165182	<p align="center">Valve Guide Arbor</p> <p>Use with Seat Cutter ST-257 to cut valve seat pockets for oversize seats. Can also be used with Gauge ST-685-4 to check valve seat concentricity.</p>	
3376405	<p align="center">Valve Seat Grooving Tool</p> <p>Cuts groove in valve seat. This is often required prior to use of valve seat extractor. Requires cutter bit Part Number 3376407. Cutter Bit is sold separately.</p>	
3165183	<p align="center">Valve Seat Cutters</p> <p>3165183 = .010 Oversize, 3165184 = .020 Oversize. Used with Valve Seat Cutter ST-257.</p>	

Tool No.	Tool Description	Tool Illustration
<p>ST-257</p>	<p align="center">Valve Seat Cutter</p> <p>Used to cut valve seat pockets for oversize seats. Valve Guide Arbor Part Number 3165182 and cutter bit Part Number 3165183 or Part Number 3165184 also required.</p>	 <p>© Cummins Inc. Cummins Inc. © Cummins Inc. Cummins Inc. 22d00237</p>
<p>3375960</p>	<p align="center">Valve Spring Compressor</p> <p>Used with cylinder head removed. Quickly removes springs using shop air.</p>	 <p>© Cummins Inc. Cummins Inc. © Cummins Inc. Cummins Inc. 22d00238</p>
<p>3375432</p>	<p align="center">Crack Detection Kit (dye type)</p>	 <p>© Cummins Inc. Cummins Inc. © Cummins Inc. Cummins Inc. 22d00239</p>

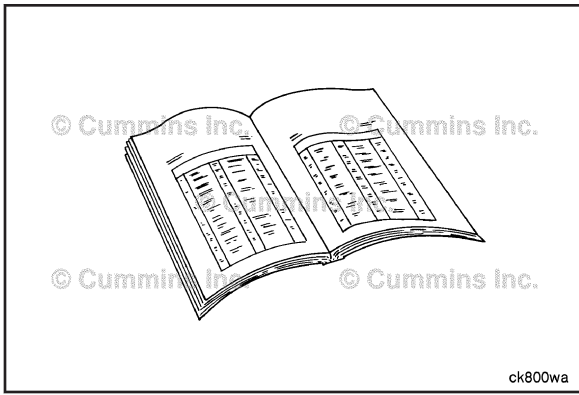

Crosshead (002-001)

Preparatory Steps



Remove rocker lever cover. Refer to Procedure Procedure 003-011

Remove rocker lever. Refer to Procedure Procedure 003-008

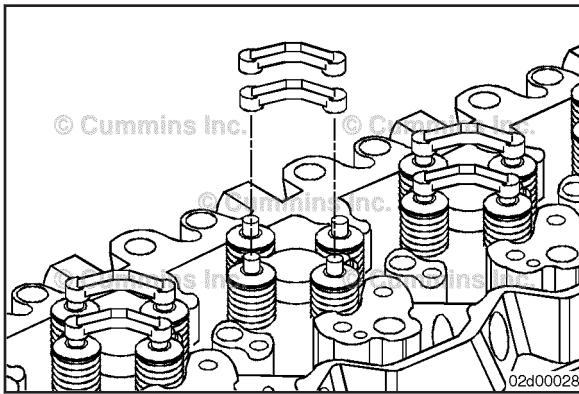

Remove

NOTE: Make note of the crosshead location and orientation. If the crossheads are reused, they **must** be installed in their original location and orientation.

Remove the crossheads.

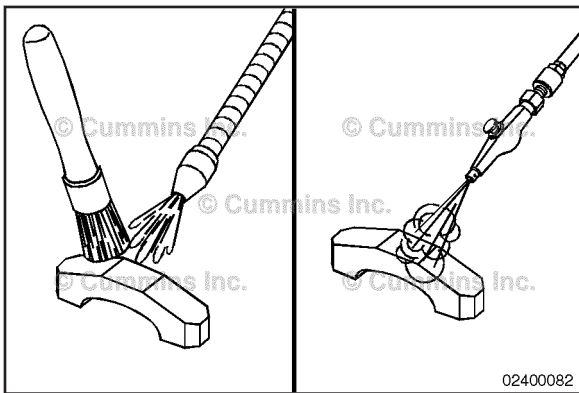

Clean and Inspect for Reuse

⚠ WARNING ⚠

When using solvents, acids, or alkaline materials for cleaning, follow the manufacturer's recommendations for use. Wear goggles and protective clothing to reduce the possibility of personal injury.

⚠ WARNING ⚠

Wear appropriate eye and face protection when using compressed air. Flying debris and dirt can cause personal injury.

Clean the crossheads with solvent. Dry with compressed air.

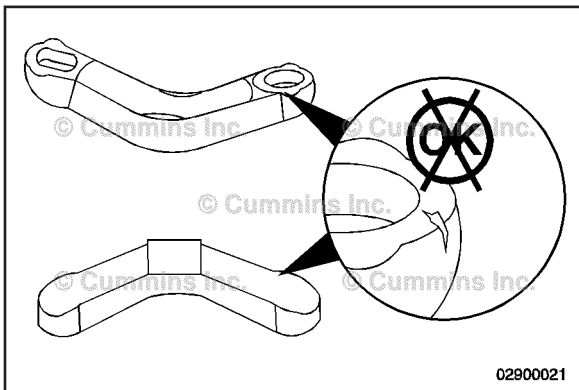

Inspect the crossheads for cracks and/or excessive wear on rocker lever and valve tip mating surfaces.

Inspect the contact pads for cracks and other damage.

Replace the crossheads if any damage is found.

Install

NOTE: The crosshead has a round and oval hole. If installing new crossheads, it is **not** required to place the holes in a particular position. If crossheads are being reused, make sure to install them in their original location and orientation.

Install the crossheads on the valve stems.

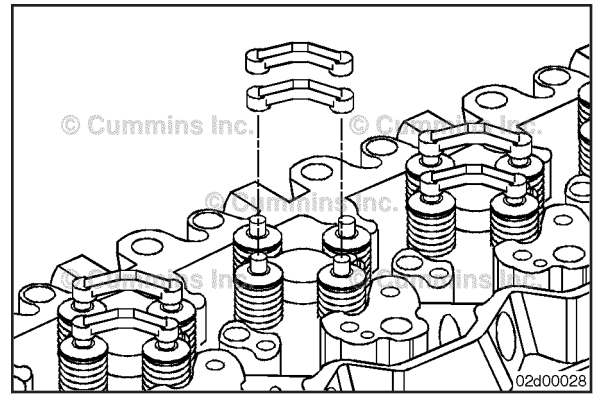

Finishing Steps

Install rocker lever. Refer to Procedure Procedure 003-008

Install rocker lever cover and gasket. Refer to Procedure Procedure 003-011

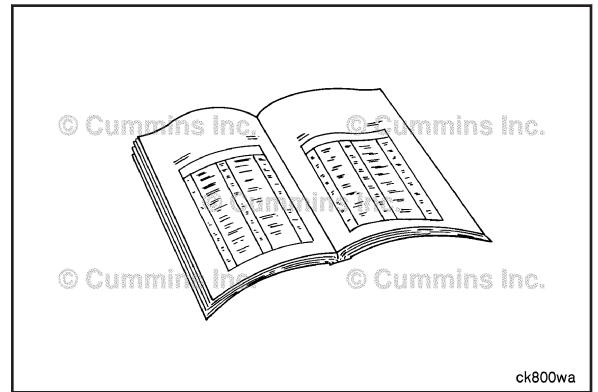

Run the engine and check for leaks.

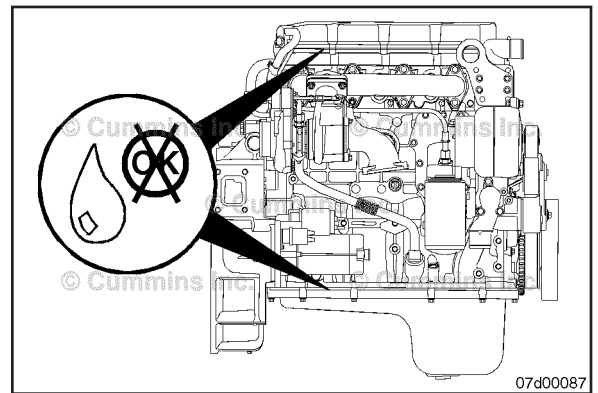

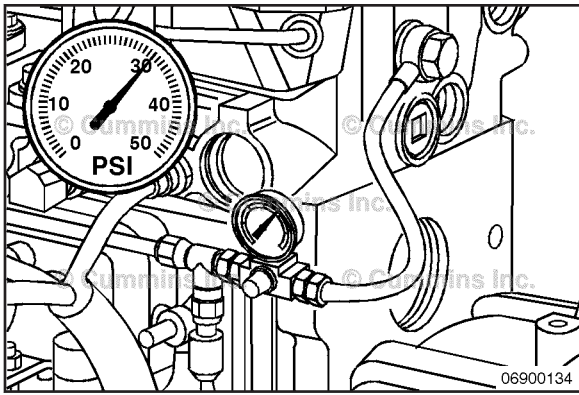

Cylinder Head (002-004)

Test

▲ WARNING ▲

Wear appropriate eye and face protection when using compressed air. Flying debris and dirt can cause personal injury.

If troubleshooting coolant in the fuel, fuel in the coolant, fuel in the oil, or oil in the fuel, pressurize the internal fuel drain line in the cylinder head and check for leaks.

Remove the fuel drain line at the back of the cylinder head. Refer to Procedure 006-013 in Section 6.

If equipped with a quick disconnect fitting at the cylinder head, remove the check valve. Refer to Procedure 006-013 in Section 6.

Connect a regulated air supply hose to the cylinder head fuel drain port with a shutoff valve on the air supply side of the pressure gauge.

Apply air pressure.

Air Pressure

kPa		psi
276	NOM	30

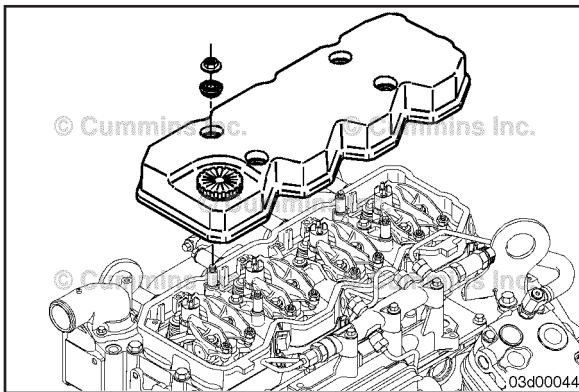

Shut off the air supply to the fuel drain port and monitor the pressure gauge reading. The pressure should hold steady. If the pressure drops rapidly, check for leaks around the:

- Test fittings
- Fuel connectors at the cylinder head

Remove the rocker lever cover and check for air bubbles around the injectors. Refer to Procedure 003-011 in Section 3.

Remove the radiator cap and check for air bubbles in the cooling system.

If the source of the leak can not be determined, remove the cylinder head and pressure test the complete cylinder head. See the Pressure Test section of this procedure. Replace the cylinder head, if necessary.

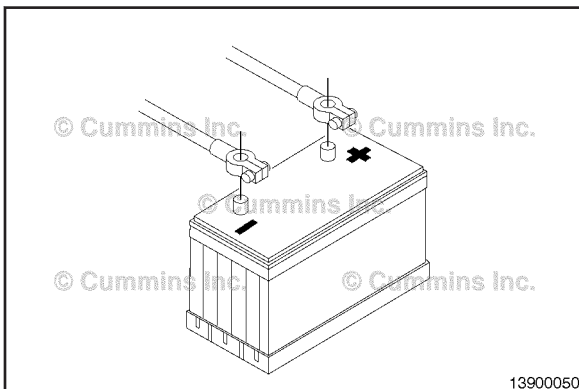

Preparatory Steps

Automotive and Industrial

▲ WARNING ▲

Batteries can emit explosive gases. To reduce the possibility of personal injury, always ventilate the compartment before servicing the batteries. To reduce the possibility of arcing, remove the negative (-) battery cable first and attach the negative (-) battery cable last.

Disconnect the batteries. Refer to the OEM service manual.



WARNING
Coolant is toxic. Keep away from pets and children. If not reused, dispose of in accordance with local environmental regulations.



WARNING
Do not remove the pressure cap from a hot engine. Wait until the coolant temperature is below 50°C [120°F] before removing the pressure cap. Heated coolant spray or steam can cause personal injury.

Drain the coolant. Refer to Procedure 008-018 in Section 8.

Remove any OEM accessories attached to the cylinder head. Refer to the OEM service manual.

Disconnect the air crossover connection. Refer to Procedure 010-019 in Section 10.

Disconnect all water and heater hoses attached to the cylinder head. Refer to Procedure 008-045 in Section 8.

NOTE: Omit the following steps if the engine is **not** equipped with exhaust gas recirculation (EGR).

If equipped, remove the exhaust pressure sensor plumbing. Refer to Procedure 011-027 in Section 11.

Remove the EGR connection tubes. Refer to Procedure 011-024 and Refer to Procedure 011-025 in Section 11.

Remove the EGR cooler and coolant lines. Refer to Procedure 011-019 and Refer to Procedure 011-031 in Section 11.

Disconnect the EGR valve and coolant lines, if equipped. Refer to Procedure 011-022 and Refer to Procedure 011-030 in Section 11.

NOTE: Omit the following steps if the engine is **not** equipped with the component or if it is **not** necessary to remove the component to remove the cylinder head. For some components, it is only necessary to remove the component if the cylinder head is being replaced or rebuilt.

Remove the fuel filter and fuel filter head. Refer to Procedure 006-017 in Section 6.

Remove the air intake connection and starting aid, if equipped. Refer to Procedure 010-080 in Section 10.

Remove the air intake manifold. Refer to Procedure 010-023 in Section 10.

Remove the drive belt. Refer to Procedure 008-002 in Section 8.

Remove the fan hub pulley. Refer to Procedure 008-039 in Section 8.

Remove the fan hub assembly. Refer to Procedure 008-036 in Section 8.

Loosen the alternator link, mounting bolt, and water inlet connection capscrews. Remove the alternator bracket mounting capscrews. Pivot the alternator away from the engine. Refer to Procedure 013-001 in Section 13.

Remove the alternator bracket from the thermostat housing. Refer to Procedure 013-003 in Section 13.

Remove the thermostat housing and thermostat from the engine. Refer to Procedure 008-013 in Section 8.

Use the following procedure to remove the coolant temperature sensor in the ISB, ISBe2, ISBe3, ISBe4, QSB4.5, QSB5.9, QSB6.7, ISC, QSC8.3, ISL, ISLe3, ISLe4, and QSL9 CM850 Electronic Control System Troubleshooting and Repair Manual, Bulletin 4021416. Refer to Procedure 019-019 in Section 19.

NOTE: The follow components are required to be removed in order to remove the cylinder head.

Remove the turbocharger. Refer to Procedure 010-033 in Section 10.

Remove the exhaust manifold. Refer to Procedure 011-007 in Section 11.

Remove the rocker lever cover and rocker lever housing. Refer to Procedure 003-011 and Refer to Procedure 003-013 in Section 3.

Remove the rocker levers and crossheads. Refer to Procedure 003-008 in Section 3 and Refer to Procedure 002-001 in Section 2.

Remove the push rods. Refer to Procedure 004-014 in Section 4.

Remove the fuel drain lines. Refer to Procedure 006-013 in Section 6.

Remove the injector supply lines (high-pressure). Refer to Procedure 006-051 in Section 6.

Disconnect the fuel rail from the cylinder head. Refer to Procedure 006-060 in Section 6.

Remove the fuel connectors (head-mounted). Refer to Procedure 006-052 in Section 6.



CAUTION
If removing the cylinder head with the injectors installed, be careful not to damage the tips of the injector. Do not set the cylinder head down on the combustion face with the injectors installed. Damage to the injector tips will result.

NOTE: Do **not** remove the injectors at this time. Remove the cylinder head with the injectors installed so that injector protrusion can be checked.

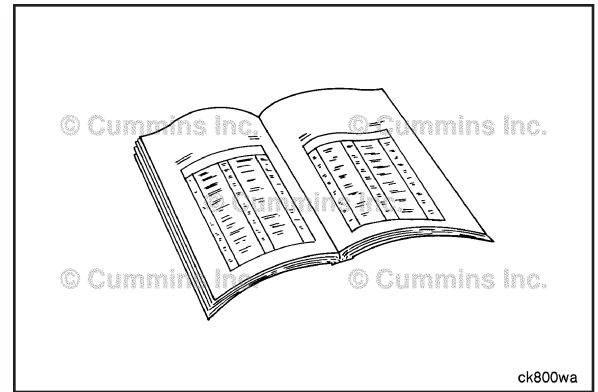

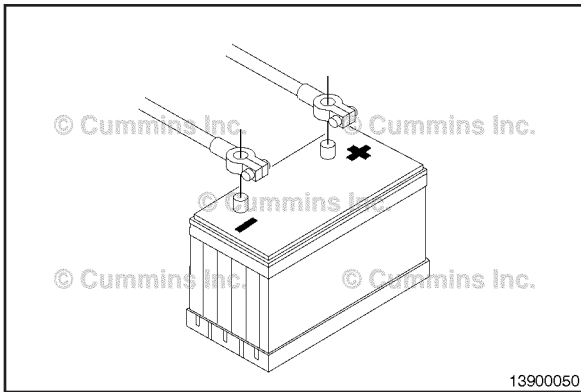

Marine Applications

⚠ WARNING ⚠

Batteries can emit explosive gases. To reduce the possibility of personal injury, always ventilate the compartment before servicing the batteries. To reduce the possibility of arcing, remove the negative (-) battery cable first and attach the negative (-) battery cable last.

Disconnect the batteries. Refer to the OEM service manual.



WARNING
Coolant is toxic. Keep away from pets and children. If not reused, dispose of in accordance with local environmental regulations.



WARNING
Do not remove the pressure cap from a hot engine. Wait until the coolant temperature is below 50°C [120°F] before removing the pressure cap. Heated coolant spray or steam can cause personal injury.



CAUTION
Before disconnecting the exhaust outlet piping, be sure to fasten the piping above the water level to prevent the vessel from taking on water and possibly sinking.

Drain the coolant. Refer to Procedure 008-018 in Section 8.

Remove the coolant expansion tank. Refer to Procedure 008-052 in Section 8.

Shut off the sea water supply valves. Refer to the OEM service manual.

Drain the sea water system. Refer to the OEM service manual.

Remove the aftercooler. Refer to Procedure 010-005 in Section 10.

Remove the belt guards. Refer to Procedure 008-001 in Section 8.

Use the following procedure to remove the engine coolant temperature sensor in the ISB, ISBe2, ISBe3, ISBe4, QSB4.5, QSB5.9, QSB6.7, ISC, QSC8.3, ISL, ISLe3, ISLe4, and QSL9 CM850 Electronic Control System Troubleshooting and Repair Manual, Bulletin 4021416. Refer to Procedure 019-019 in Section 19.

Remove the sea water pump and support. Refer to Procedure 008-058 in Section 8.

Remove the heat exchanger. Refer to Procedure 008-053

Remove the closed crankcase breather system. Refer to Procedure 003-020 in Section 3.

Remove the marine gear oil cooler bracket capscrews. Refer to Procedure 008-041 in Section 8.

Remove the turbocharger and exhaust manifold as an assembly. Refer to Procedure 011-008 in Section 11.

Remove the rocker lever cover and rocker lever housing. Refer to Procedure 003-011 and Refer to Procedure 003-013 in Section 3.

Remove the rocker levers and crossheads. Refer to Procedure 003-008 in Section 3 and Refer to Procedure 002-001 in Section 2.

Remove the push rods. Refer to Procedure 004-014 in Section 4.

Remove the injector supply lines (high-pressure). Refer to Procedure 006-051 in Section 6.

Remove the fuel drain lines. Refer to Procedure 006-013 in Section 6.

Remove the fuel and lubricating oil filter bracket. Refer to Procedure 002-033 in Section 2.

Remove the fuel rail from the cylinder head. Refer to Procedure 006-060 in Section 6.

Remove the fuel connectors (head-mounted). Refer to Procedure 006-052 in Section 6.

Remove the air intake manifold. Refer to Procedure 010-023 in Section 10.

Remove the thermostat housing assembly. Refer to Procedure 008-013 in Section 8.



CAUTION
If removing the cylinder head with the injectors installed, be careful not to damage the tips of the injector. Do not set the cylinder head down on the combustion face with the injectors installed. Damage to the injector tips will result.

NOTE: Do not remove the injectors at this time. Remove the cylinder head with the injectors installed so that injector protrusion can be checked.

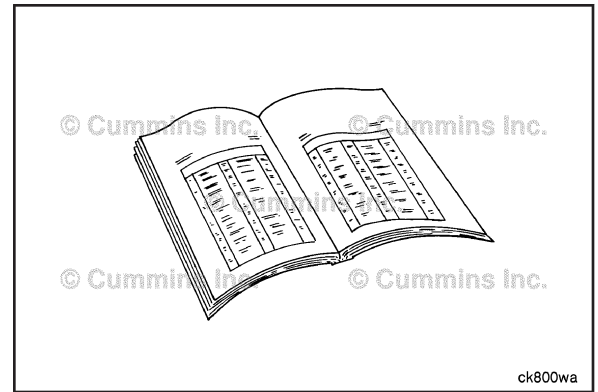

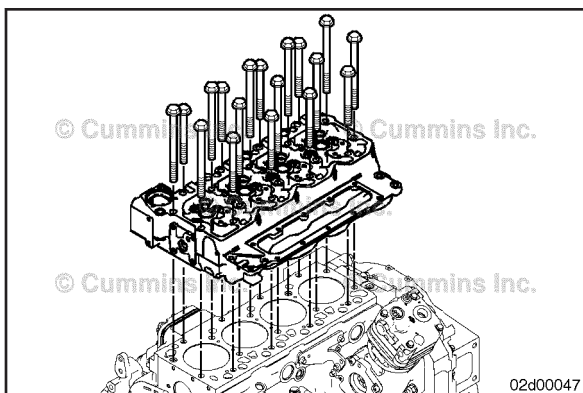

Remove

⚠ WARNING ⚠

This component weighs 23 kg [50 lb] or more. To reduce the possibility of personal injury, use a hoist or get assistance to lift this component.

⚠ CAUTION ⚠

If removing the cylinder head with the injectors installed, be careful not to damage the tips of the injector. Do not set the cylinder head down on the combustion face with the injectors installed. Damage to the injector tips will result.

Remove the cylinder head capscrews and cylinder head.

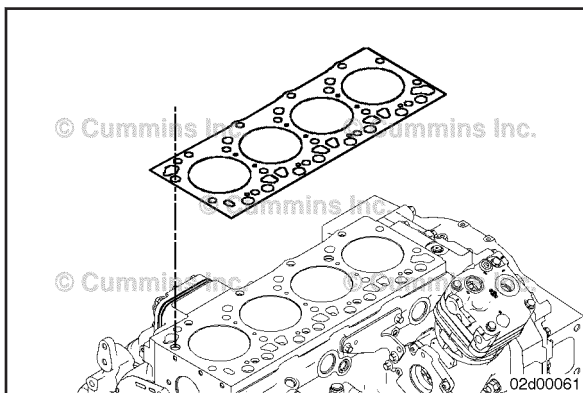

Remove the cylinder head gasket from the cylinder block.

NOTE: Do **not** discard the head gasket. For some engines that require head gasket grading, the head gasket will help to determine which replacement head gasket to use. Refer to Procedure 002-021 in Section 2.

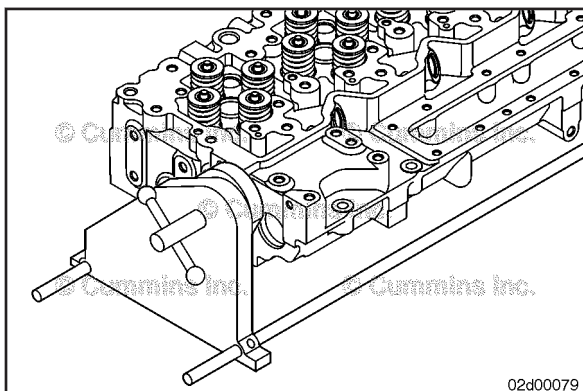

Initial Check

Install the cylinder head in the cylinder head holding fixture, Part Number ST-583.

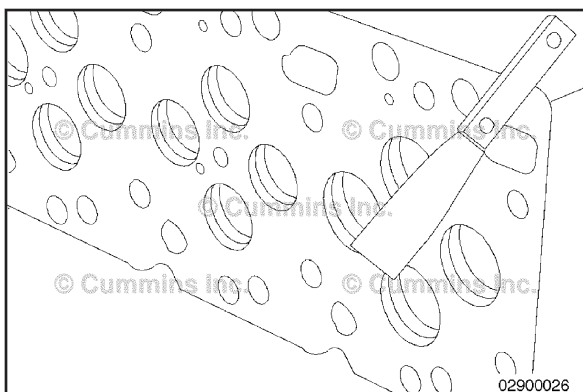

Scrape the gasket material and clean the combustion deck surfaces on the cylinder block and cylinder head.

Use a straightedge and a feeler gauge to inspect the cylinder head combustion surface for flatness.

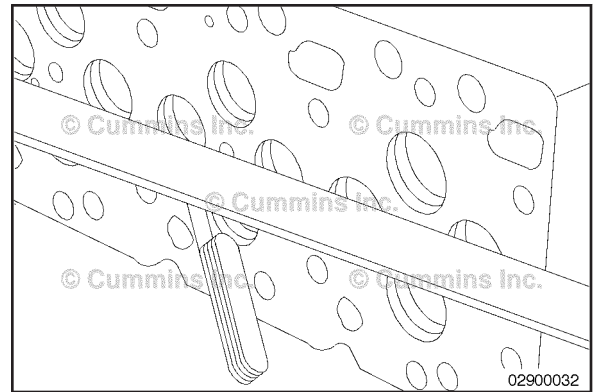

Cylinder Head Flatness

	mm		in
End-to-End	0.305	MAX	0.012
Side-to-Side	0.076	MAX	0.003

If out of specification, determine if the cylinder head can be resurfaced or if the cylinder head must be replaced by:

- 1 Measuring and recording valve depth
- 2 Measuring and recording injector protrusion.

If valve depth and injector protrusion specifications can be maintained, the cylinder head can be resurfaced. If the specifications can **not** be maintained, the cylinder head **must** be replaced.

Install depth gauge assembly, Part Number 3164438, on the cylinder head combustion deck and zero.

Rotate the depth gauge so that it is measuring the injector protrusion at the highest point on the injector.

Record the injector protrusion for each injector.

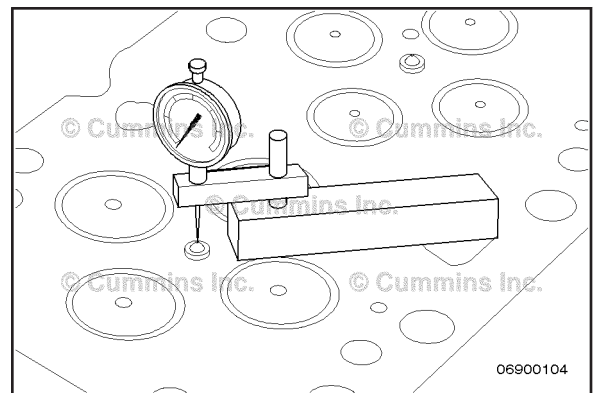

Injector Protrusion

mm		in
2.45	MIN	0.096
3.15	MAX	0.124

NOTE: Do **not** use thicker or double stacked injector sealing washers to correct injector protrusion. This will cause misalignment of the high-pressure fuel connector.



If the injector protrusion is out of specification, check the thickness of the injector sealing washer. Refer to Procedure 006-026 in Section 6.

If the sealing washer is the correct thickness, check to make sure the injector bore is clean and free of debris. Also make sure that sealing washers are **not** 'stacked' in the injector bore.

If the injector protrusion is within specification, remove the injector. Refer to Procedure 006-026 in Section 6.

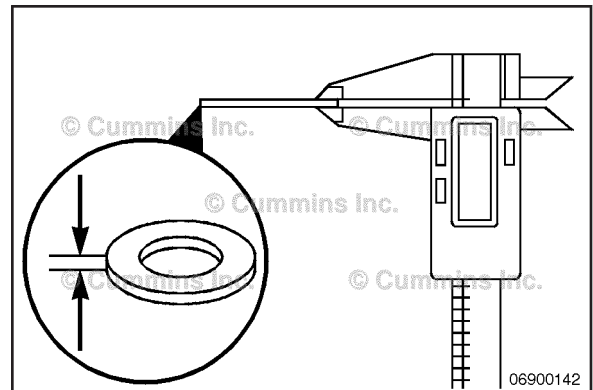

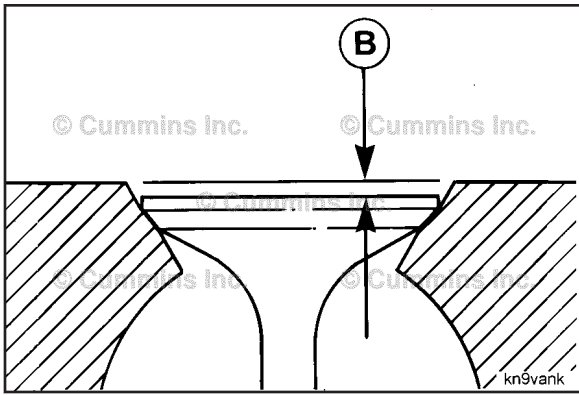

Install depth gauge assembly, Part Number 3164438, on the cylinder head combustion deck and zero.

Rotate the depth gauge so that it is measuring the valve recession into the cylinder head (A).

Record the valve depth for each valve.



Intake Valve Depth (Installed)

mm		in
0.584	MIN	0.023
1.092	MAX	0.043

Exhaust Valve Depth (Installed)

mm		in
0.965	MIN	0.038
1.473	MAX	0.058

NOTE: Valve depth can be increased slightly for resurfacing of the cylinder head by lapping the valves.

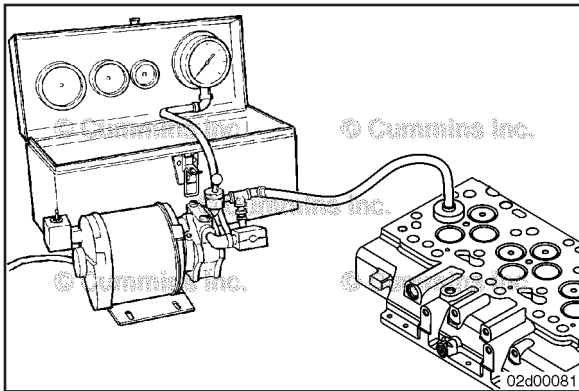

If a leaking valve is suspected or if the cylinder head was recently rebuilt, vacuum test the valves and valve seats using valve vacuum tester, Part Number 3824277, and cup, Part Number ST-1257-6. The vacuum **must not** drop more than 25.4 mm Hg [1.0 in Hg] in five (5) seconds.

NOTE: If a vacuum tester is **not** available, with the valve removed, use a lead pencil or Dykem® to mark across the valve face. Install the valve in the valve guide. Hold the valve against the valve seat, and rotate the valve backward and forward three or four times. Correct contact against the valve seat will break the marks on the valve face.

Valve to Valve Seat Vacuum

	kPa		in Hg
Used	51	NOM	15
New	69	NOM	20

If out of specification, disassemble the cylinder head and inspect for damaged valves and/or valve seats. Repair as necessary by:

- 1 Cleaning the valve/valve seat and lapping the valves
- 2 Replacing the damaged valve seat, if available
- 3 Replacing the cylinder head.

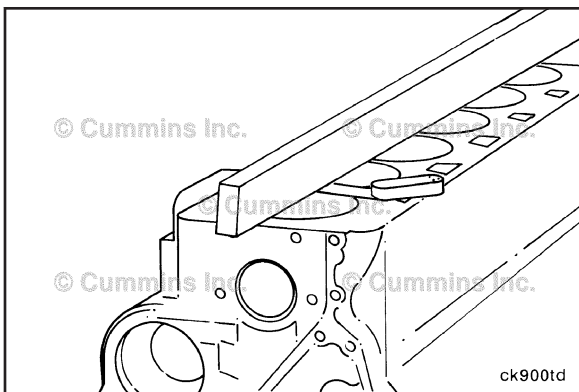

Use a straightedge and feeler gauge to measure the overall flatness of the cylinder block.

Cylinder Block Flatness

	mm		in
End-To-End	0.075	MAX	0.003
Side-To-Side	0.075	MAX	0.003



Inspect the combustion deck for any localized dips or imperfections.

If out of specification, determine if the cylinder block can be resurfaced or if the cylinder block **must** be replaced. Refer to Procedure 001-026 in Section 1.

Disassemble

Mark the valves to identify their location.

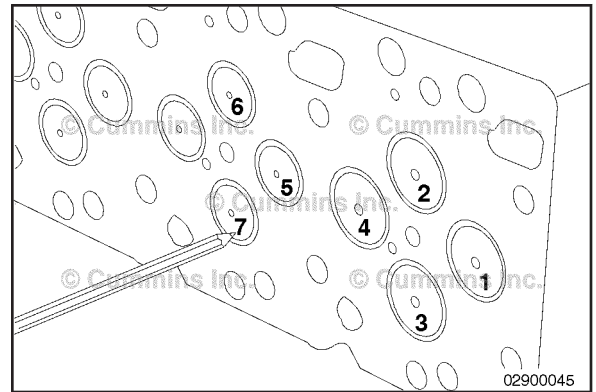

Compress the valve springs using the valve spring compressor service tool, Part Number 3164329.



Position the replacer screw (4) above the injector bore and install the two capscrews (5) in the cylinder head where the hold-down clamp screws were removed.



Tighten the capscrews (5).

Torque Value: 5 N•m [44 in-lb]

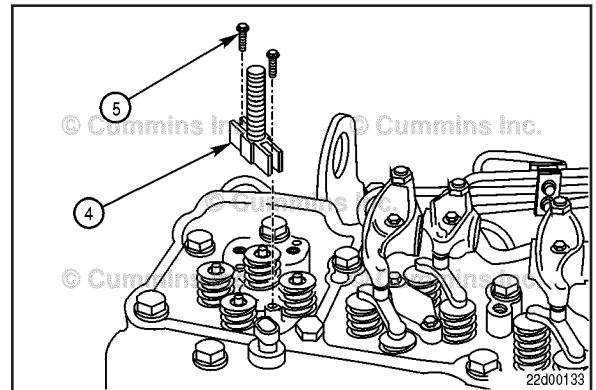

NOTE: The valves are **not** evenly spaced from the injector bore. It is important to align the slots in the valve spring compressor plate with the valve springs.



Apply anti-seize lubricant to the replacer screw (4) threads. Always read and follow label precautions.



Position the valve spring compressor plate (1) on the replacer screw (4) and align the slots in the valve spring compressor plate with the valve springs.

Install the washer (3) and nut (2) on the replacer screw (4).

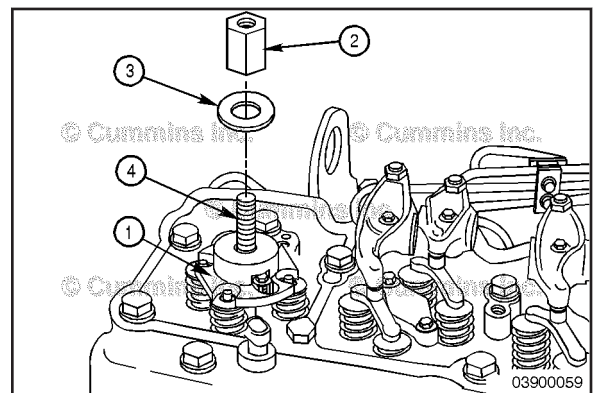

⚠ WARNING ⚠

Valve springs are under tension and can act as projectiles if released. To reduce the possibility of eye injury, wear safety glasses with side shields.



Turn the nut (2) **clockwise** to compress the valve springs.

Continue turning the nut (2) **clockwise** until the valve collets can be removed using a magnetic tool, such as the end of a magnetic screwdriver.

Remove the valve collets and the valve spring compressor service tool.

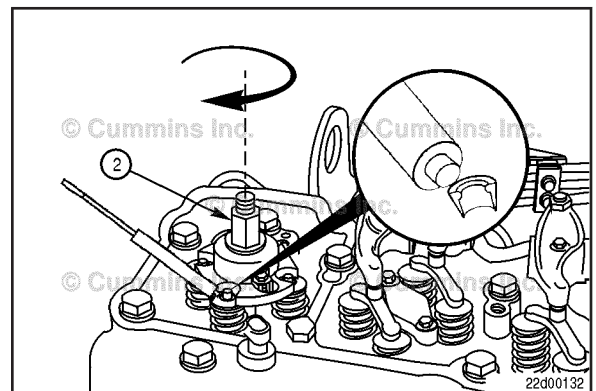

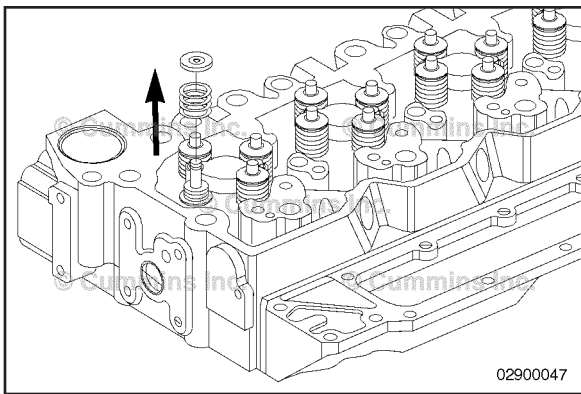

Remove the valve spring retainer and valve springs.

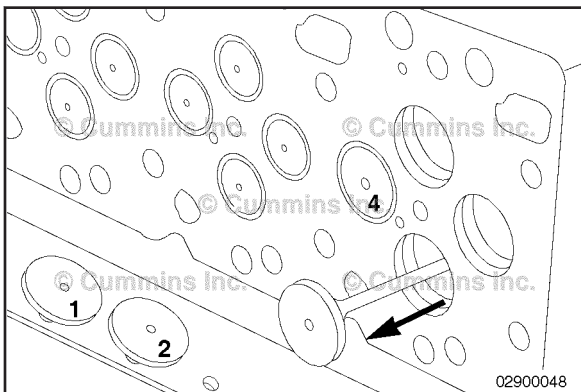

NOTE: Keep the valves in a labeled rack with the associated valve collets, spring retainers, and springs. This will aid in assembling the components as a matched set.

Remove the valves.

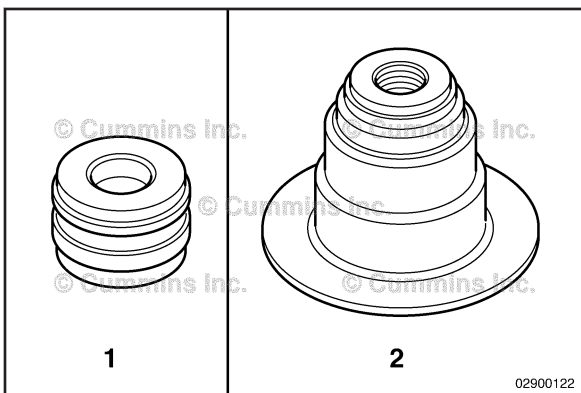

NOTE: Prior to removing the valve stems seals, note the type and color of the valve stem seal installed at each valve location. The same type and color valve stem seal **must** be installed when assembling the cylinder head.

There are two types of valve stem seals used:

1 "Drive-On" Seal

Colors Used:

- Green (used for exhaust valves)
- Yellow (used for intake valves).

1 "Top-Hat" Seal

Colors Used:

- Green (used for exhaust valves)
- Yellow (used for intake and exhaust valves).

Use boot pliers, Part Number 3163293, to remove the valve stem seals.

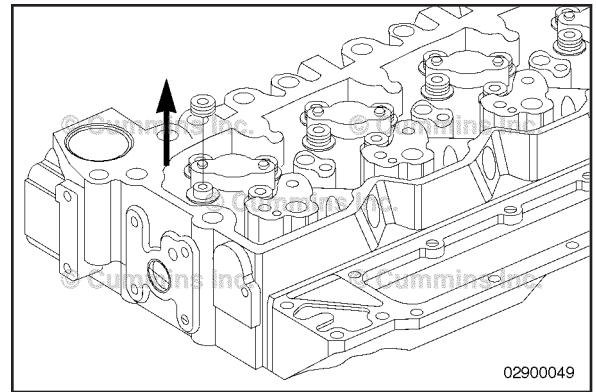

NOTE: Prior to removing the valve seat inserts, see the Initial Check and Clean and Inspect for Reuse steps in this procedure. The condition of the valve, the amount of recess, and the sealing of the valve on the seat insert all help determine whether or **not** a seat insert needs to be replaced.



- 1 If required, remove the valve seat inserts.
- 2 Inspect the valve-insert-to-cylinder-head contact area. A sufficient groove for the remover **must** exist.
- 3 If there is sufficient valve insert groove area, proceed to the next step.
- 4 If the valve insert groove area is **not** sufficient, use the valve seat insert cutting kit, Part Number 3376405, to create a sufficient groove.

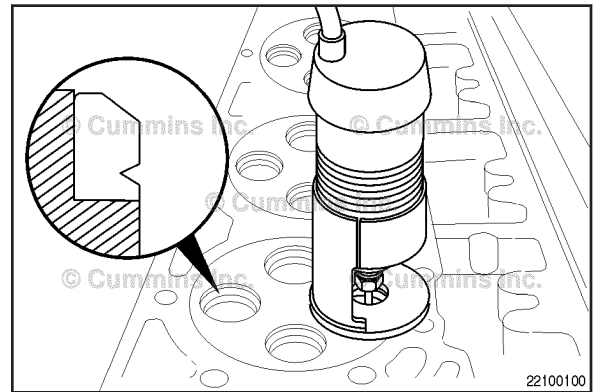

Use the slide hammer remover, Part Number 3376617, with valve insert remover, Part Number 3165170, to remove the valve seats.



NOTE: Make certain that the valve insert remover assembly is perpendicular to the cylinder head when installed.



Insert the valve insert remover assembly into the valve insert and rotate the T-handle **clockwise** until the remover loosely grips the valve insert.

Position the valve insert remover assembly into the valve insert groove area. Tighten the T-handle firmly, allowing the remover to expand under the valve insert or into the cut groove.

Strike the slide hammer remover against the top nut until the valve insert is removed. Turn the T-handle **counterclockwise** to release the valve insert from the remover.

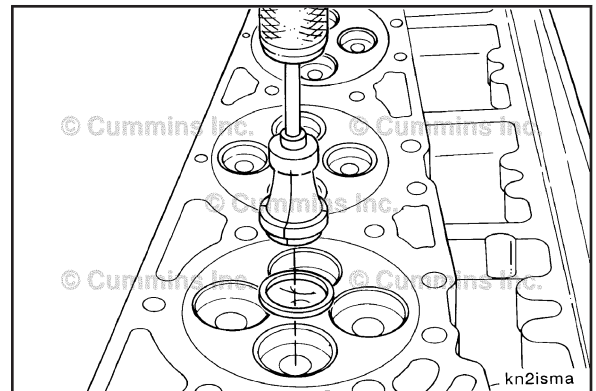

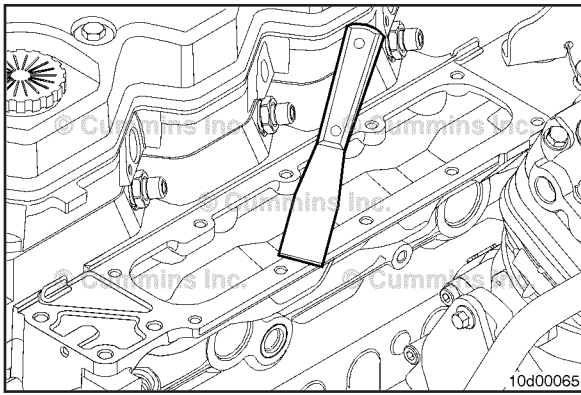

Clean and Inspect for Reuse

NOTE: Keep the gasket material and any other material out of the air intake.

If removed, clean the cylinder head sealing surfaces where the air intake manifold seals.

NOTE: On engines equipped with EGR, it is common to have soot buildup in the air intake section of the cylinder head. If the cylinder head is removed as part of another repair, it is **not** necessary to clean the soot from the intake.

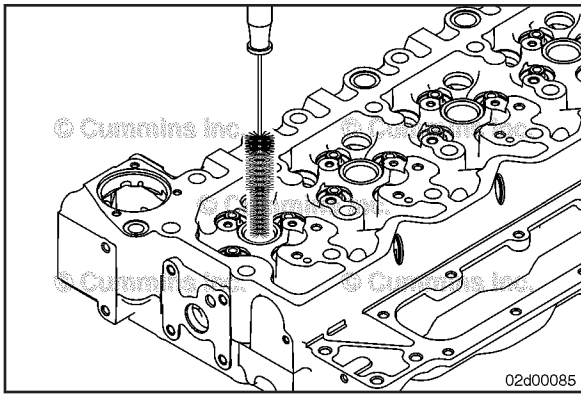

Use an injector bore brush, Part Number 3822510, or equivalent, to clean the carbon from the injector seat.

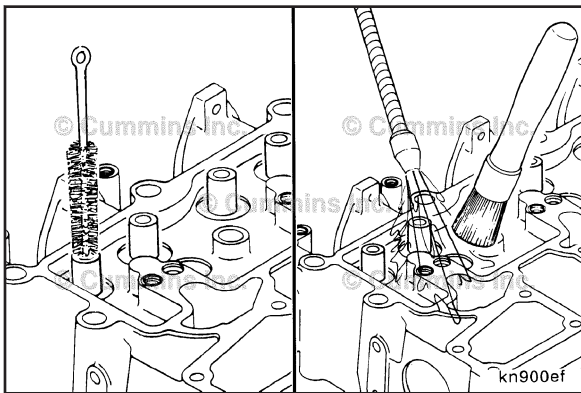

⚠ WARNING ⚠

Wear appropriate eye and face protection when using compressed air. Flying debris and dirt can cause personal injury.

Use a bristle brush to clean the inside diameter of the valve guide bore and blow out with compressed air.

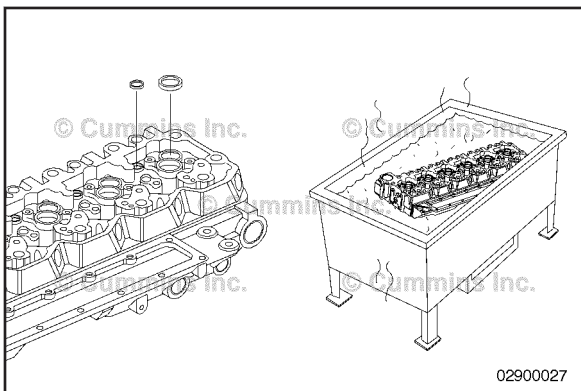

NOTE: Excessive deposits can be cleaned in an acid tank, but the expansion plugs **must** be removed first. Refer to Procedure 017-002 in Section 17.



If required, clean the buildup of deposits in the coolant passages.

⚠ WARNING ⚠

When using solvents, acids, or alkaline materials for cleaning, follow the manufacturer's recommendations for use. Wear goggles and protective clothing to reduce the possibility of personal injury.

⚠ WARNING ⚠

Some solvents are flammable and toxic. Read the manufacturer's instructions before using.

Clean the cylinder head combustion deck with an abrasive hand pad, Part Number 3823258, or equivalent, and solvent.

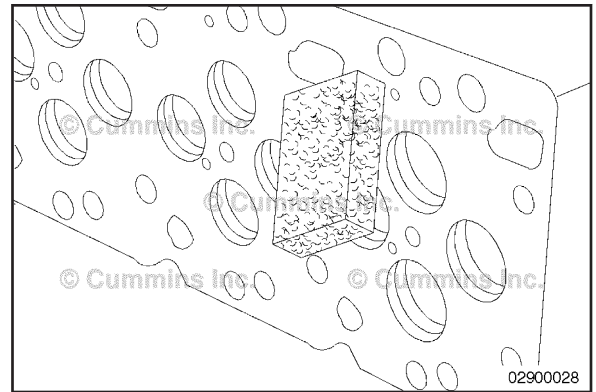

⚠ WARNING ⚠

Wear protective eye covering while cleaning carbon deposits to reduce the possibility of personal injury.

⚠ CAUTION ⚠

Contacting the valve seat with the wire wheel while it is spinning will damage the valve seat. If this occurs, new valve seats must be cut or new valve seat inserts must be installed.

Inspect the area within 1/8-inch of the firing ring diameter. Any wear that can be felt with a fingernail within the 1/8-inch area is unacceptable, making the cylinder head **not** reusable. Wear beyond this 1/8-inch area will have no effect on future combustion sealing and the usability of the cylinder head.

Clean carbon deposits from the valve pockets with a high-quality steel wire wheel installed in a drill or die grinder.

NOTE: An inferior-quality wire wheel will lose steel bristles during operation, causing additional contamination.

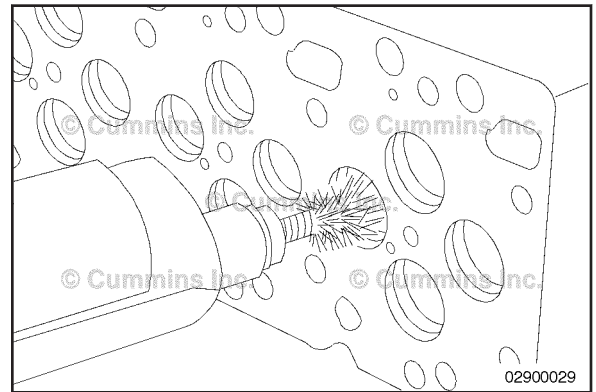

⚠ WARNING ⚠

Wear appropriate eye and face protection when using compressed air. Flying debris and dirt can cause personal injury.

Use a wire brush and solvent to clean the deposits from the valve seat insert bores if it was necessary to remove the valve seat inserts.

Dry with compressed air.

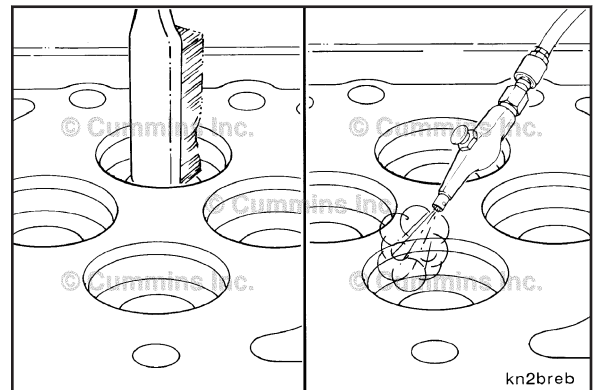

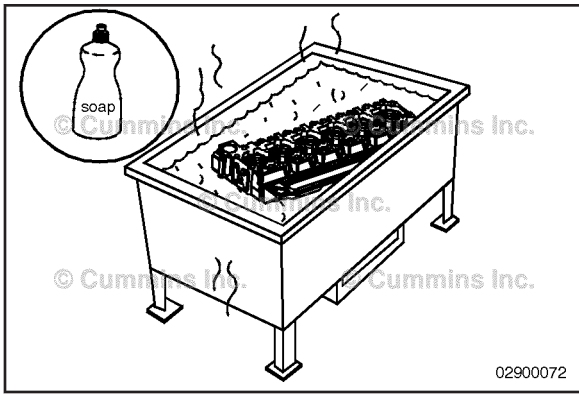

⚠ WARNING ⚠
Wear appropriate eye and face protection when using compressed air. Flying debris and dirt can cause personal injury.

Wash the cylinder head in a hot, soapy water solution.

Rinse the cylinder head with clean water.

Dry the cylinder head with compressed air.

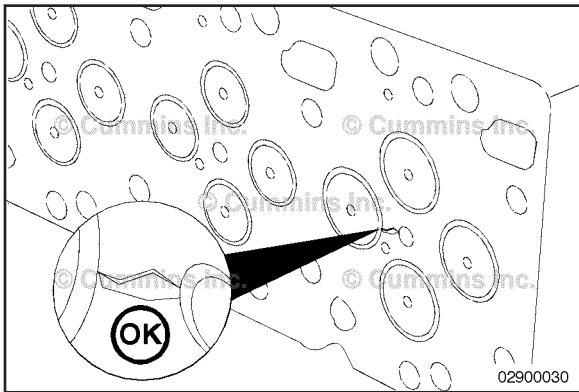

Cylinder Head Cracks - Reuse Guidelines

With the cylinder head cleaned, re-inspect the cylinder head for signs of cracks, fretting, and discoloration that would prohibit reuse.

To help identify cracks in the cylinder block, use the Crack Detection Kit, Part Number 3375432.

Pay close attention to areas of the cylinder head that include:

- Injector bore
- Combustion face
- Valve seats
- Valve guides.

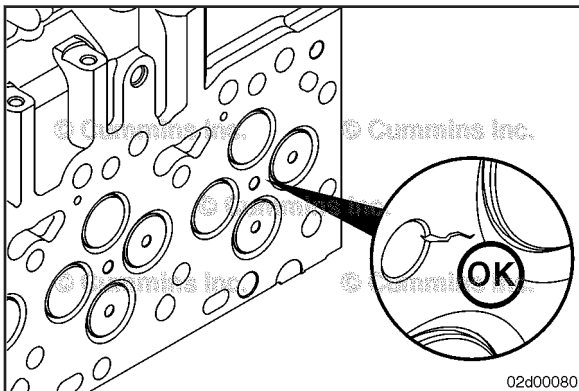

The reuse guidelines for a cylinder head with a crack extending from the injector bore to the intake valve seat are as follows:

- If the crack does **not** extend into the valve seat, the cylinder head is reusable.

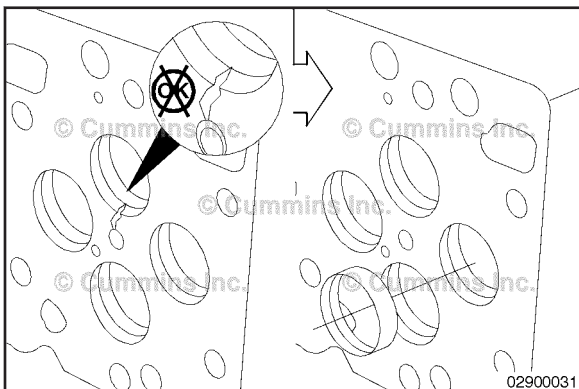

- If the crack extends into or through the valve seat, the cylinder head **must** be replaced.

⚠ CAUTION ⚠
Failure to replace the cylinder head for a crack that extends into or through the valve seat bore will result in a valve seat insert falling out. Engine damage will result.

If still installed, inspect the valve seats for cracks or burnt spots.

If the valve seat inserts are damaged, for some cylinder heads, the valve seat inserts can be replaced.

- 1 Verify replacement valve seat inserts are available.
- 2 If replacement valve seat inserts are available and require placement, see the Disassembly Step.
- 3 If replacement valve seat inserts are **not** available, the cylinder head **must** be replaced.

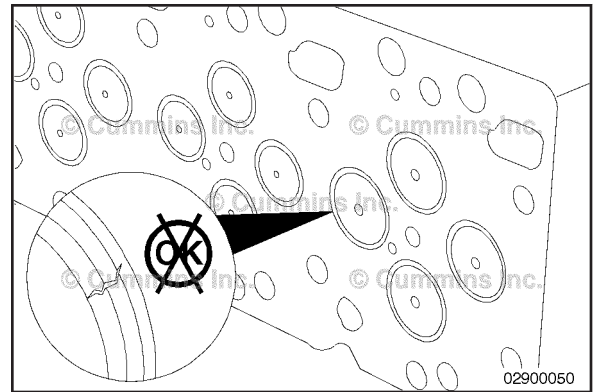

If the valve seat insert was removed in the Disassemble Step, measure the inside diameter of the valve seat insert bore in the cylinder head.

Cylinder Head Insert Bore Inside Diameter (I.D.)

mm		in
34.847	MIN	1.3719
34.863	MAX	1.3726

NOTE: Before cutting the cylinder head, verify valve seat inserts are available for the engine being serviced. If none are available, the cylinder head **must** be replaced.

If out of specification, the valve seat insert bore can be oversized .254 mm (.010 in) and/or .508 mm (.020 in).

Use ST257 Valve Seat Insert Tool Kit with Valve Guide Arbor, Part Number 3165184, to cut cylinder head to accept oversized valve seat inserts. Use valve seat cutter, Part Numbers 3165183 (.254 mm (.010 in) or 3165184 (508 mm (.020 in)).

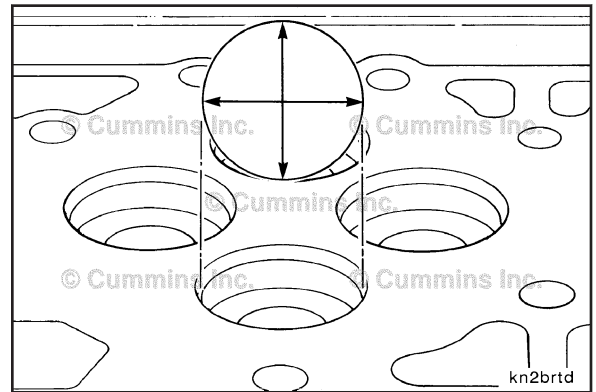

Valve Guide - Reuse Guidelines

Inspect the valve guides for scuffing or scoring.

Measure the valve guide inner diameter (I.D.)

Valve Guide Bore Diameter

mm		in
7.027	MIN	0.2767
7.077	MAX	0.2786

If the valve guide bore is worn larger than the maximum specified or if inspection reveals damaged valve guides, the cylinder head **must** to be replaced.

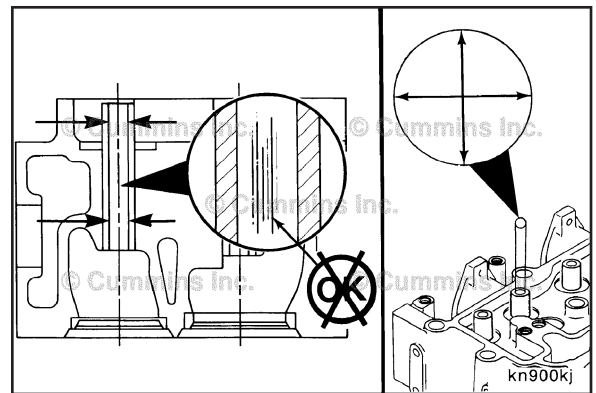

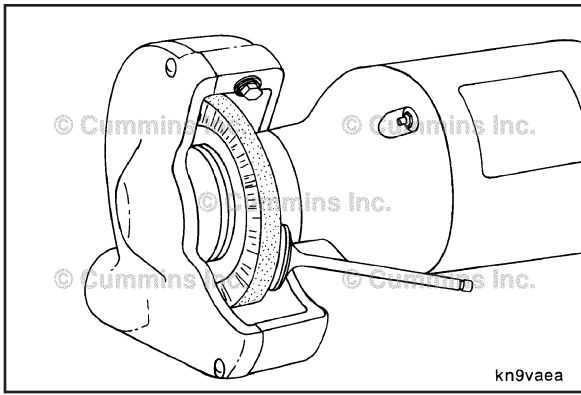

⚠ WARNING ⚠

Wear protective eye covering when cleaning the valves with a wire wheel to reduce the possibility of personal injury.



Clean the valve heads with a soft wire wheel.

NOTE: Keep the valves in a labeled rack to prevent mixing before taking measurements.

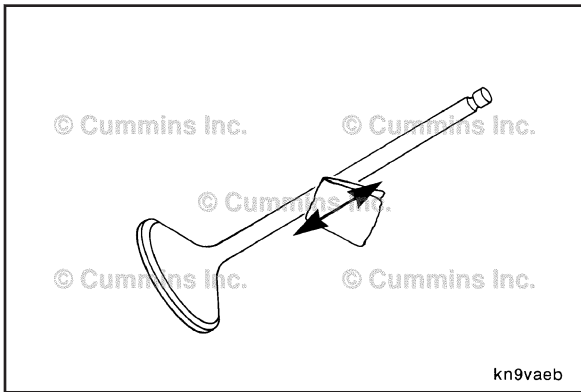

⚠ WARNING ⚠

When using solvents, acids, or alkaline materials for cleaning, follow the manufacturer's recommendations for use. Wear goggles and protective clothing to reduce the possibility of personal injury.

Polish the valve stems with an abrasive pad, Part Number 3823258, and solvent.

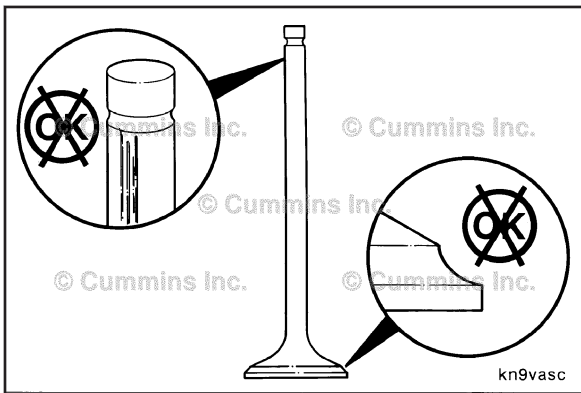

Valve - Reuse Guidelines

Inspect the valves for:

- Excessive wear on the heads and stems
- Excessive wear on the valve stem tip
- Bends and distortion.

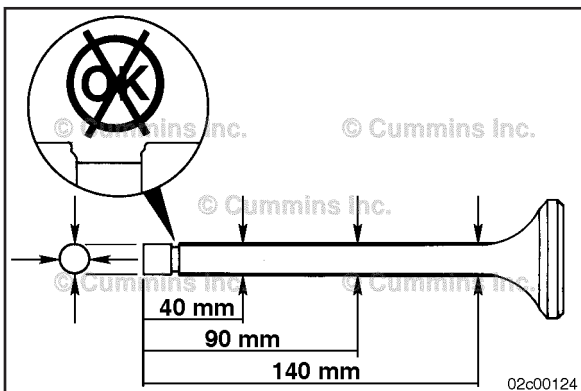

Inspect the valves for damage and the collet grooves for wear.

Measure the outside diameter of the valve stem.



Three measurements must be taken of each valve stem at 40 mm [1.57 in], 90 mm [3.54 in], and 140 mm [5.51 in] from the tip end.

Valve Stem Diameter

mm		in
6.96	MIN	0.2740
7.01	MAX	0.2760

If the valves are damaged or the stems are worn smaller than the minimum specified, the valves **must** be replaced.

Valve Spring - Reuse Guidelines

Inspect the valve springs.

Measure the valve spring. Place a square adjacent to the spring and use a feeler gauge to measure the clearance at the top spring coil.

Approximate Free Length (L): 47.75 mm [1.88 in]

Maximum Inclination: 1.5 mm [0.059 in]

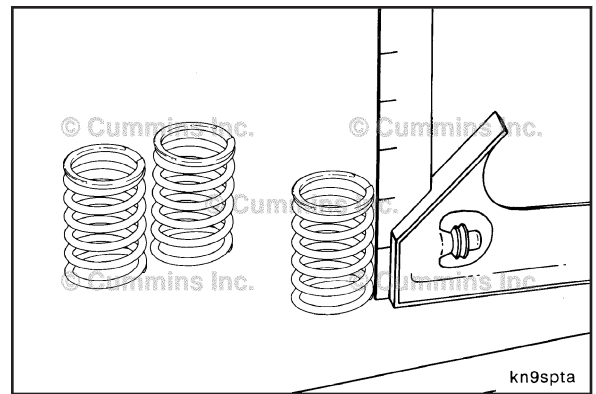
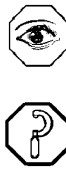

Use valve spring tester, Part Number 3375182, to compress the valve spring. A load of 320.8 to 358.8 N [72 to 80.7 lb] is required to compress a spring to a height of 35.33 mm [1.39 in].

NOTE: If the valve spring is **not** within specification, a new valve spring **must** be used.

NOTE: Valve springs **must** be replaced in pairs under the same cross head. If one spring does **not** meet the specification, replace both valve springs under the same cross head.

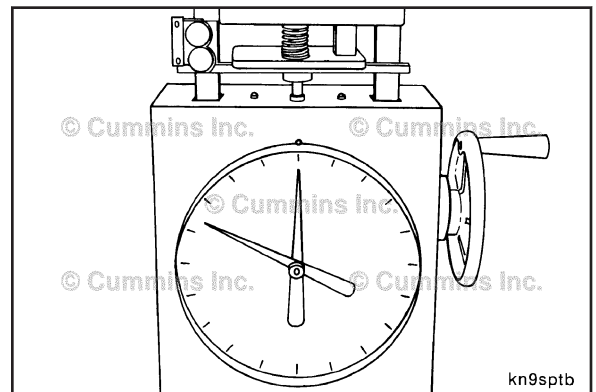

Inspect the valve spring retainers and valve collets for damage or worn areas.

Discard and replace damaged and worn parts.

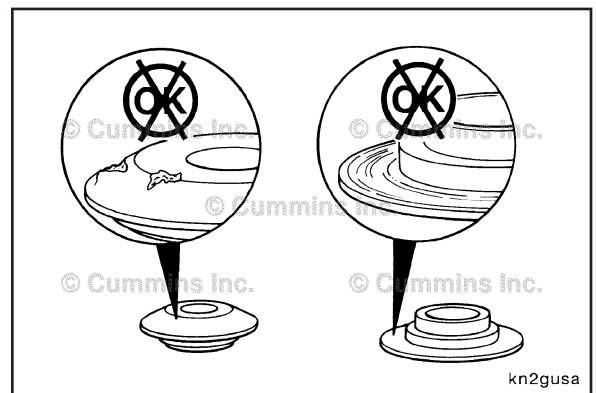

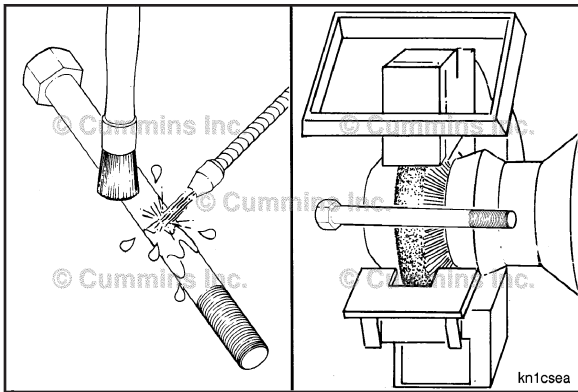

⚠ WARNING ⚠
When using solvents, acids, or alkaline materials for cleaning, follow the manufacturer's recommendations for use. Wear goggles and protective clothing to reduce the possibility of personal injury.

⚠ WARNING ⚠
Some solvents are flammable and toxic. Read the manufacturer's instructions before using.

⚠ CAUTION ⚠
Do not use caustic or acid solutions to clean the cylinder head cap screws. Component damage can occur.

Use a petroleum-based solvent to clean the cap screws.

Clean the cap screws thoroughly with a wire brush, soft wire wheel, or nonabrasive bead blast to remove deposits from the shank and threads.

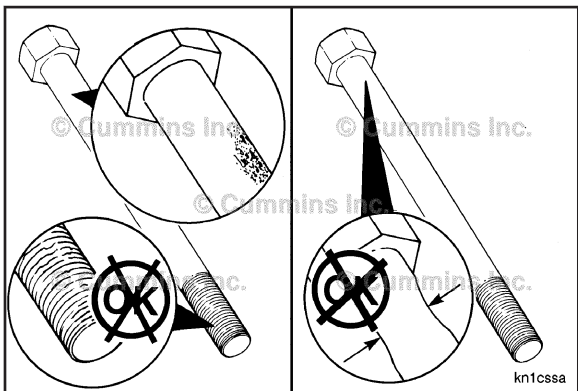

Cylinder Head Cap screw - Reuse Guidelines

Inspect the cylinder head cap screws for damaged threads, corroded surfaces, or a reduced diameter (due to cap screw stretching).

Do **not** reuse cylinder head cap screws under the following conditions:

- Visible corrosion or pitting exceeding 1 sq cm [0.155 sq in] in area.

Example:

- Acceptable is 9.525 x 9.525 mm [3/8 x 3/8 in]
- Unacceptable is 12.700 x 12.700 mm [1/2 x 1/2 in].
- Visible corrosion or pitting exceeds 0.12 mm [0.005 in] in depth.
- Visible corrosion or pitting is located within 3.2 mm [1/8 in] of the fillet or thread.
- Stretched beyond "free-length" maximum. See the measurement procedure below:

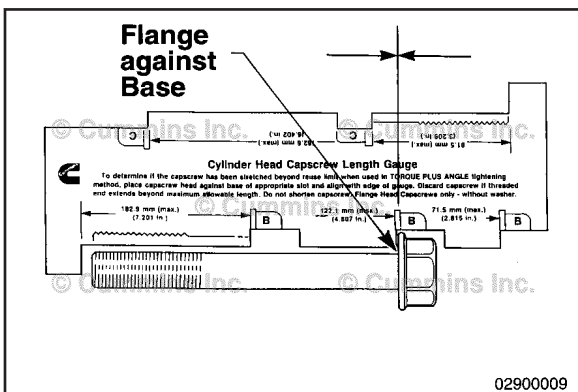

Free-Length Measurement

NOTE: If the cap screws are **not** damaged, they can be reused throughout the life of the engine unless the specified free length is exceeded.



To check the cap screw free length using cap screw length gauge, Part Number 3164057, place the head of the cap screw in the appropriate slot with the flange against the base of the slot.

NOTE: Most new cylinder head gaskets and upper engine gaskets include the cap screw length gauge, Part Number 3164057.

If the end of the capscrew touches the foot of the gauge, the capscrew is too long and **must** be discarded.



NOTE: Some 3.9L and 5.9L engines use two different length cylinder head capscrews.

Capscrew Free Length

	mm		in
Short Capscrew	132.1	MAX	5.20
Long Capscrew	152.1	MAX	5.99

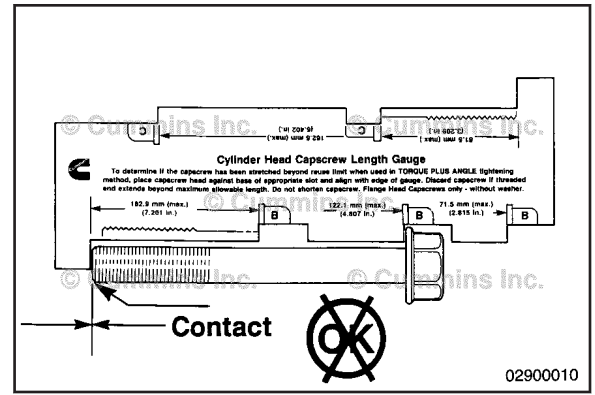

Pressure Test

If troubleshooting an internal coolant leak or coolant loss symptom, a cylinder head test fixture can be fabricated from a flat piece of steel or aluminum to pressure test the cylinder head.



See the following table for test fixture dimensions.

16 mm	Thickness	0.630 in
749 mm	Length	29.5 in
193 mm	Width	7.6 in

NOTE: Use the old cylinder head gasket as a pattern for drilling the capscrew holes.

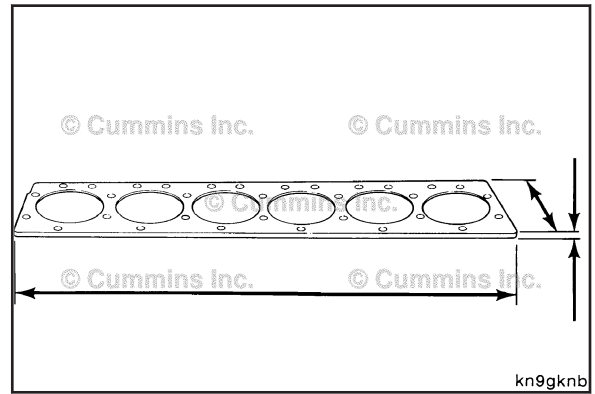

Install the thermostat, water outlet connection, and mounting capscrews.



Tighten the capscrews

Torque Value: 10 N•m [89 in-lb]

Install the engine coolant temperature sensor, located next to the water outlet connection.



Torque Value: 18 N•m [159 in-lb]

NOTE: The thermostat contains two check balls to vent air past the thermostat when closed. Install a rubber cap and hose clamp over the water outlet connection to prevent air from leaking through the check balls.

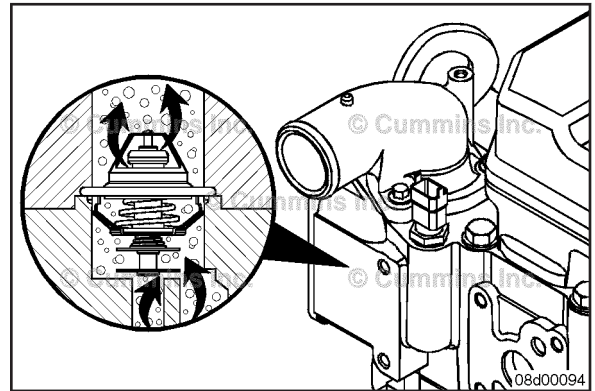

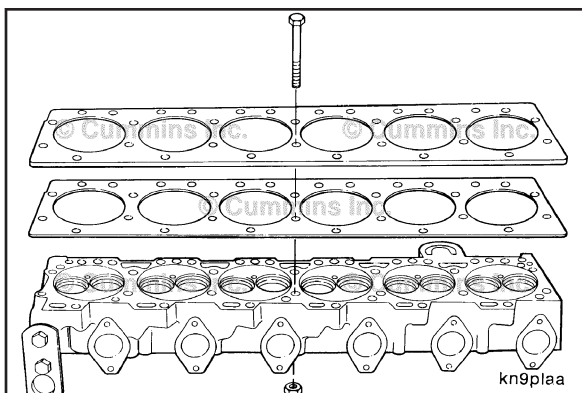

Install the cylinder head water test fixture.

- 1 Install a new head gasket.
- 2 Install the test plate.
- 3 Install the following:

For four cylinder engines:

- 18 - 180-mm-long grade 12.9 flange head capscrews
- 18 - M12 x 1.75 hex flange nuts
- 36 - 12-mm washers

For six cylinder engines:

- 26 - 180-mm-long grade 12.9 flange head capscrews
- 26 - M12 x 1.75 hex flange nuts
- 52 - 12-mm washers

NOTE: Place a washer between each capscrew and the head, and between each nut and test plate. This will prevent mutilation on the surface of the cylinder head.

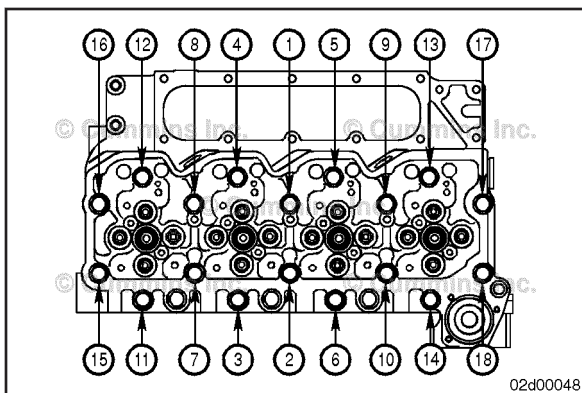

Use the illustrated sequence to tighten the four-cylinder nuts.

Torque Value: 80 N•m [59 ft-lb]

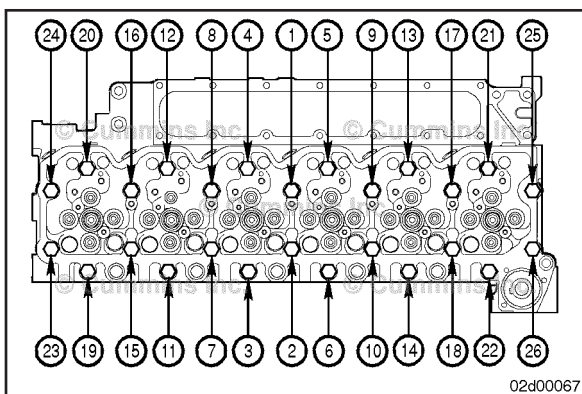

Use the illustrated sequence to tighten the six-cylinder nuts.

Torque Value: 80 N•m [59 ft-lb]



Service Tip: To apply air pressure to the cylinder head, remove one of the pipe plugs located on the exhaust side of the cylinder head. This is the same port used when the cylinder head is installed to check cylinder block coolant pressures.

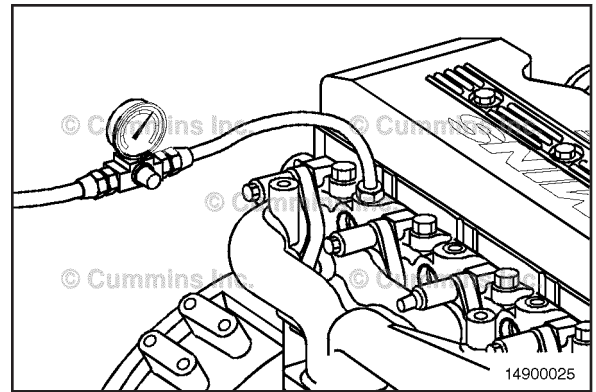

⚠ WARNING ⚠

This component weighs 23 kg [50 lb] or more. To reduce the possibility of personal injury, use a hoist or get assistance to lift this component.

NOTE: Make sure to plug or seal open coolant ports before pressure testing the cylinder head.

Connect a regulated air supply hose, Part Number 3164231, to the cylinder head.

Apply air pressure.

Air Pressure: 276 kPa [40 psi]

Use a nylon lifting strap and a hoist to place the cylinder head in a tank of heated water.

Water Temperature: 60 °C [140 °F]

NOTE: The cylinder head **must** be completely submerged in the water.

Inspect the head. Bubbles indicate an air leak.

If any bubbles exist, verify that the air leak is not coming from:

- any cup plugs or fittings installed in the cylinder head
- the test fixture or air line fittings
- water outlet connection

If the above checks out OK and bubbles are present, the cylinder head leaks and it **must** be replaced.

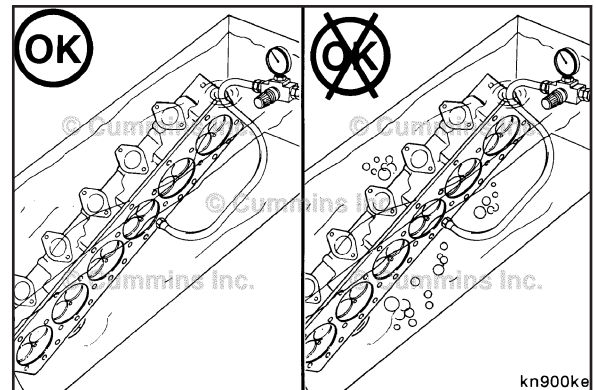
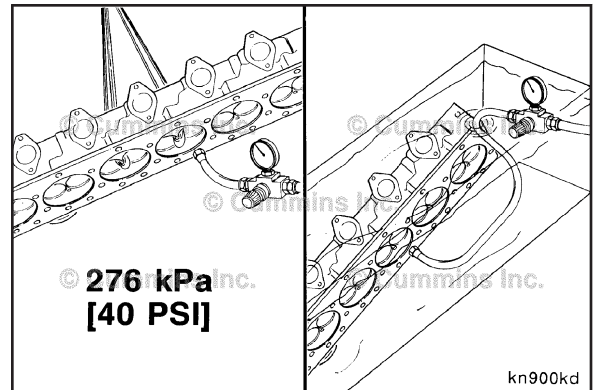

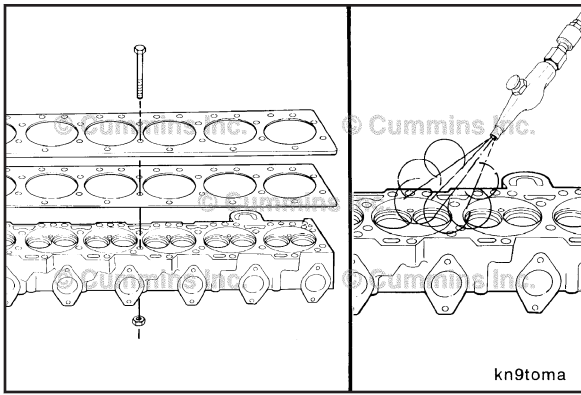

WARNING

Wear appropriate eye and face protection when using compressed air. Flying debris and dirt can cause personal injury.

Remove the test fixture.

Use compressed air to dry the cylinder head.

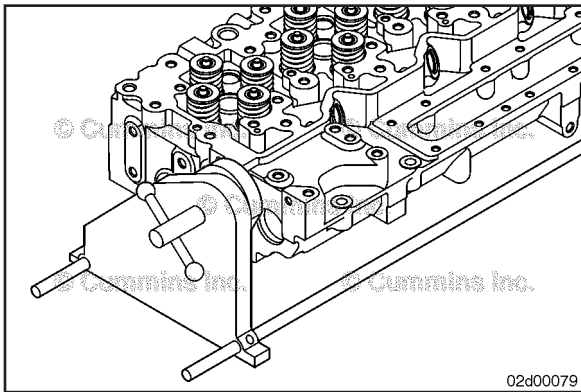

Assemble

Install the cylinder head in the cylinder head holding fixture, Part Number ST-583.

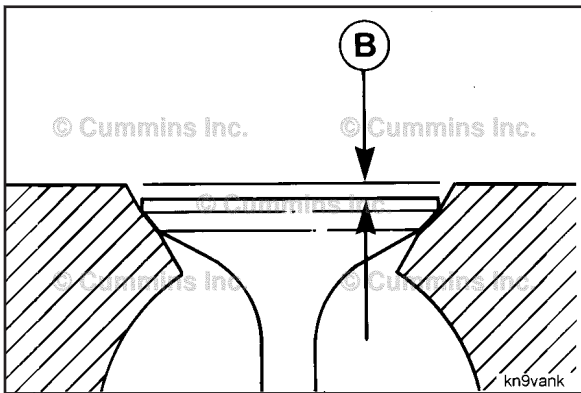

NOTE: When installing the valve seat inserts, the exhaust and intake valve seat inserts are **not** the same.

Valve seat angle:

- Intake 30-degrees
- Exhaust 45-degrees.

If new valve seat inserts are installed, check valve depth and perform a valve leak test. See the Initial Check of this procedure.

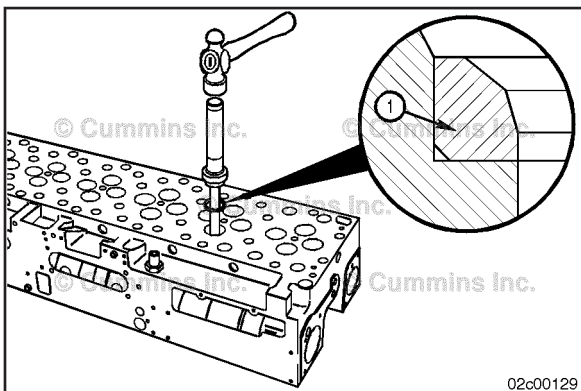

If the valve seat inserts were removed in the disassemble step, new inserts **must** be installed.

NOTE: The insert chamfer (1) **must** be installed toward the bottom of the counterbore.

Use valve seat installer, Part Number 3165171, to drive the intake and exhaust valve seat inserts into the counterbore.

Use a dead blow hammer with the seat drivers to install the new valve seat inserts.

If new valve seat inserts were installed and/or the valve leakage was above specification, the valve seat/valve can be lapped.

NOTE: Lubricate the stems with SAE 15W-40 engine oil before installing the valves.

Use a fine lapping compound, Part Number 3375805, or equivalent. Apply a thin and even coating on the valve.

Use a power or a hand suction lapping tool to provide pressure in the center of the valve.

Turn the valve backward and forward. Continue lapping until the compound shows a continuous contact pattern on both the valve seat insert and the valve.

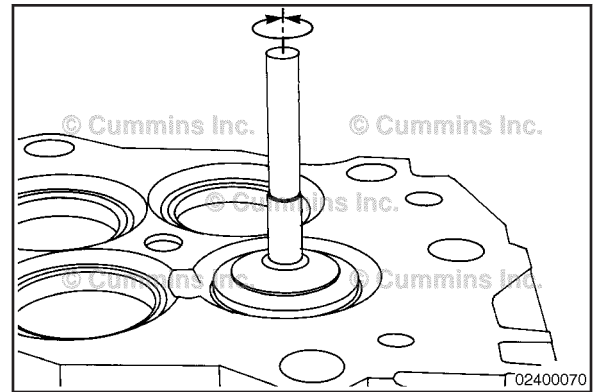

⚠CAUTION⚠

Lapping compound is an abrasive material. Failure will result if the cylinder head, the valves, and the valve seats are not cleaned thoroughly.

Clean the lapping compound from the parts.

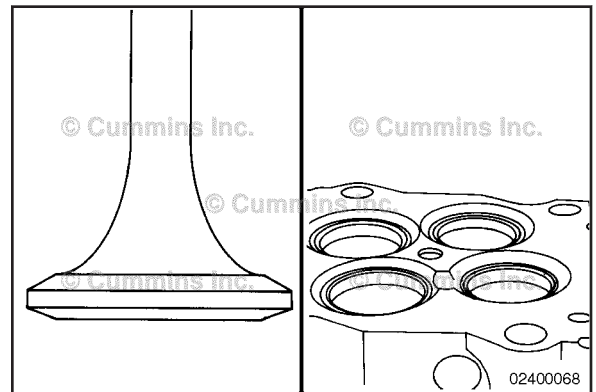

If lapping of the valves was required, measure the rim thickness to determine if there is enough rim material left.

Valve Rim Thickness Limit

mm		in
0.79	MIN	0.031

If the valve thickness is **not** within the limits, a new valve **must** be used.

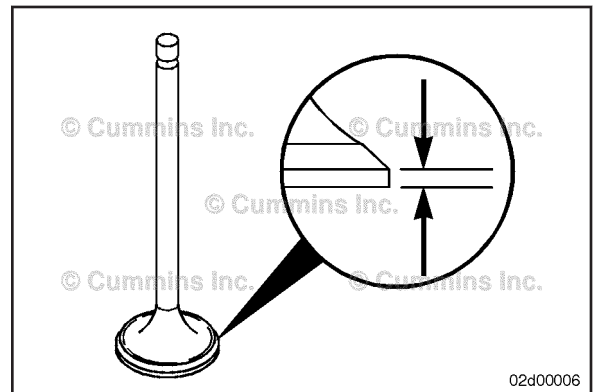

⚠CAUTION⚠

Lubricate all the valve guide bores and valve stems with SAE 15W-40 engine oil. Failure to lubricate the valve guides and valve stems can result in premature valve guide wear.

Lubricate the stems with SAE 15W-40 engine oil before installing the valves.

NOTE: If installing the same valves as previously removed, make sure to install the valves in the same locations from which the valves were removed.

NOTE: If the cylinder head will **not** be used right away, lubricate the valve stems with assembly lube, Part Number 3163087, or equivalent.

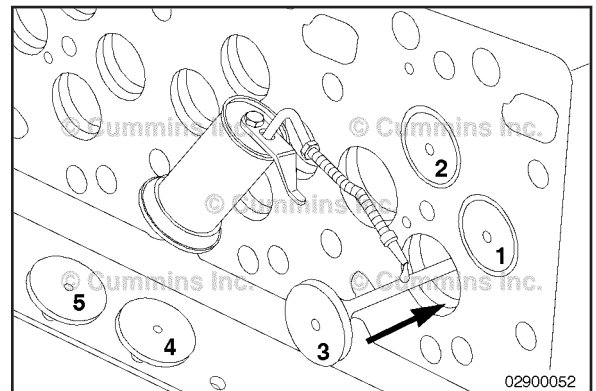

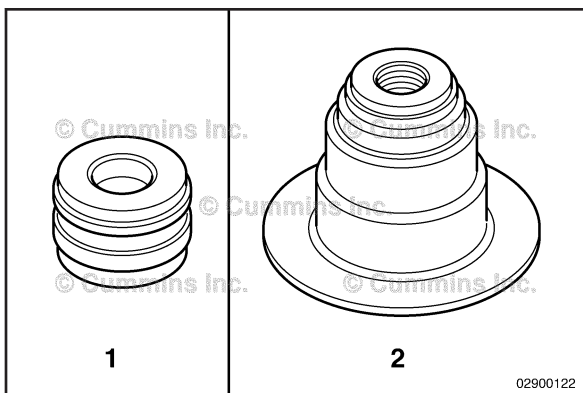

CAUTION

The same type and color valve stem seal must be installed in the same location as removed. Incorrect valve stem seals will result in excessive oil consumption and internal engine damage.

Install new valve stem seals of the same type and color as removed and in the same location.

There are two types of valve stem seals used:

1 "Drive-On" Seal

Colors Used:

- Green (used for exhaust valves)
- Yellow (used for intake valves)

1 "Top-Hat" Seal

Colors Used:

- Green (used for exhaust valves)
- Yellow (used for intake and exhaust valves)

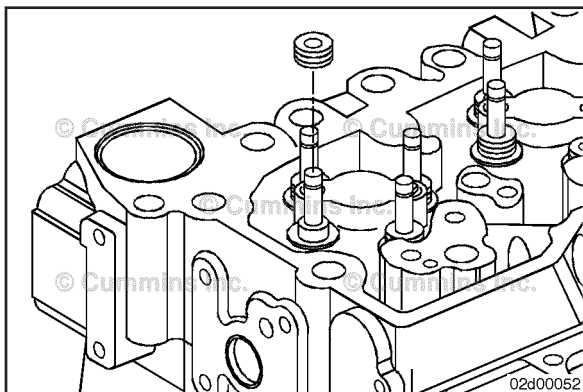

Install new valve stem seals using a valve stem installation tool, Part Number 3164055.



NOTE: The valve stem seals can be installed by hand. The installation tool will aid with installing the valve stem seals, but is **not** mandatory.



Use hand pressure to keep the valves from falling out during installation.

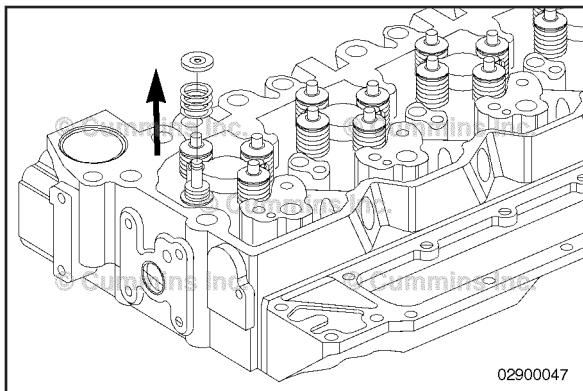

Install the valve spring retainer and valve springs.

Compress the valve springs using the valve spring compressor service tool, Part Number 3164329.

Position the replacer screw (4) above the injector bore and install the two capscrews (5) in the cylinder head where the hold-down clamp screws were removed.

Tighten the capscrews (5).

Torque Value: 5 N•m [44 in-lb]

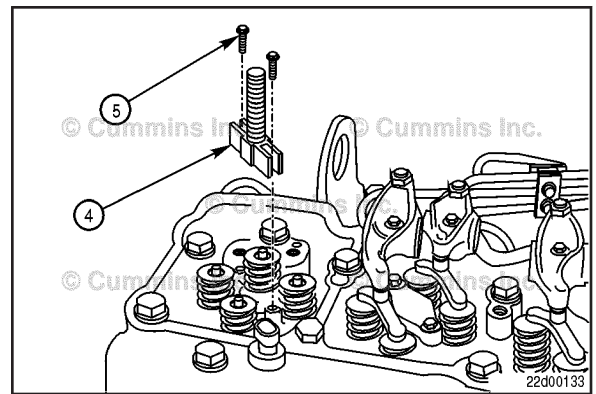

NOTE: The valves are **not** evenly spaced from the injector bore. It is important to align the slots in the valve spring compressor plate with the valve springs.

Apply anti-seize lubricant to the replacer screw (4) threads. **Always** read and follow label precautions.

Position the valve spring compressor plate (1) on the replacer screw (4) and align the slots in the valve spring compressor plate with the valve springs.

Install the washer (3) and nut (2) on the replacer screw (4).

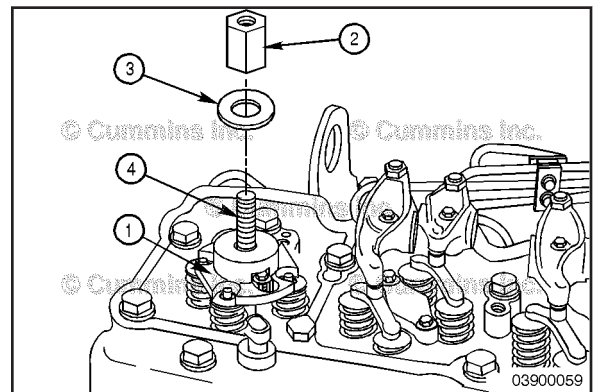

⚠ WARNING ⚠

Valve springs are under tension and can act as projectiles if released. To reduce the possibility of eye injury, wear safety glasses with side shields.

Compress the valve springs until the valve collets can be installed.

Install the valve collets.

Use assembly lube, Part Number 3163087, or equivalent, on the valve collets to help hold them in place until the valve spring compressor is released.

Remove the valve spring compressor service tool.

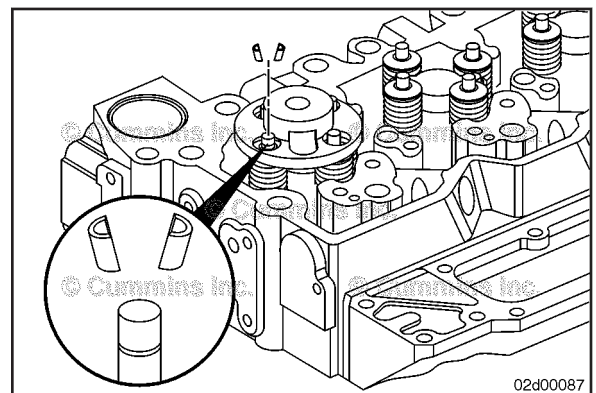

⚠ WARNING ⚠

To reduce the possibility of personal injury, wear eye protection. If the collets are not correctly installed, they can fly out when the stems are hit with a hammer.

After assembly, hit the valve stems with a plastic hammer to make sure the collets are seated.

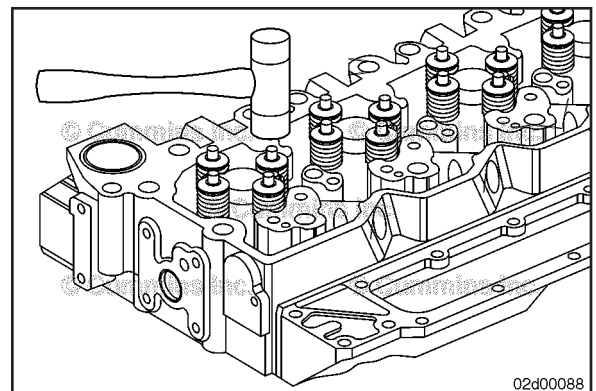

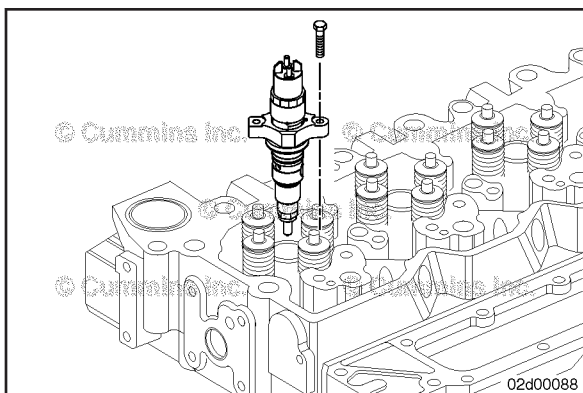

Measure

⚠ CAUTION ⚠

Improper injector protrusion can cause performance problems and high-pressure fuel leaks due to misalignment of the fuel connector.



Install the injectors with sealing washers into the cylinder head. Refer to Procedure 006-026 in Section 6.

Measure the injector protrusion.

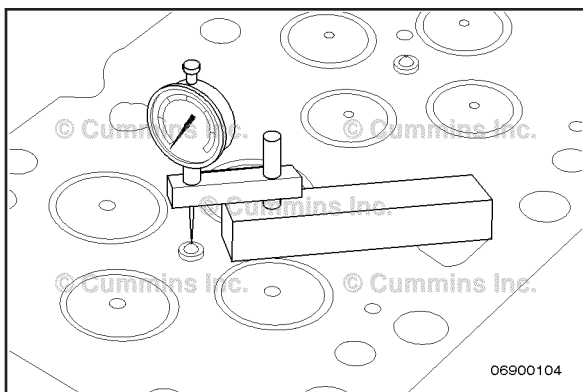

Install depth gauge assembly, Part Number 3164438, on the cylinder head combustion deck and zero.



Rotate the depth gauge so that it is measuring the injector protrusion at the highest point on the injector.

Measure the injector protrusion for each injector.

Injector Protrusion

mm		in
2.45	MIN	0.096
3.15	MAX	0.124

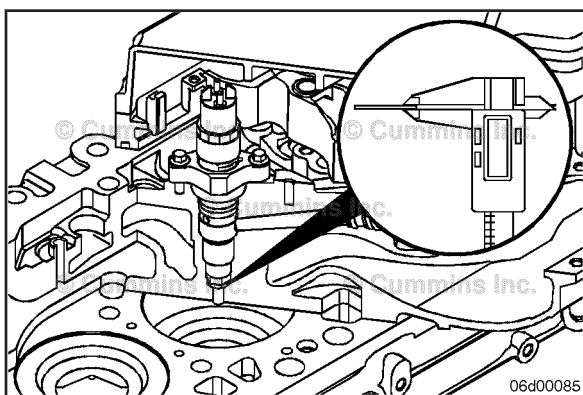

If the injector protrusion is out of specification, check the thickness of the injector sealing washer. Refer to Procedure 006-026 in Section 6.



If the sealing washer is the correct thickness, check to make sure the injector bore is clean and free of debris. Also make sure that sealing washers are **not** 'stacked' in the injector bore.

Install depth gauge assembly, Part Number 3164438, on the cylinder head combustion deck and zero.

Rotate the depth gauge so that it is measuring the valve recession into the cylinder head (A).

Measure the valve depth for each valve.

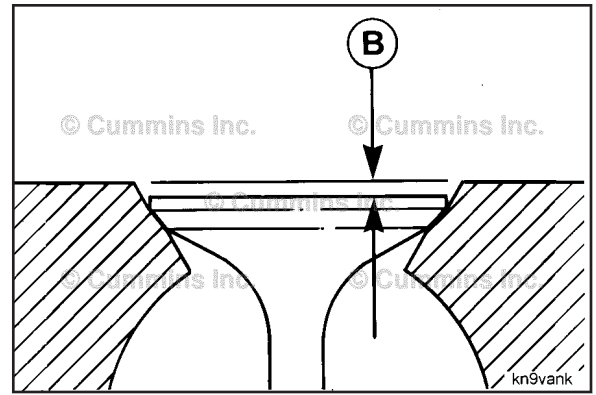

Intake Valve Depth (Installed)

mm		in
0.584	MIN	0.023
1.092	MAX	0.043

Exhaust Valve Depth (Installed)

mm		in
0.965	MIN	0.038
1.473	MAX	0.058

If the valve depth is **not** within specification, check if debris is preventing the valve from closing completely. If no debris is found, remove the valve and inspect the valve seat and valve face for damage.

Install

⚠CAUTION⚠

Make sure the gasket is correctly aligned with the holes in the cylinder block. Damage to the cylinder block can occur if the gasket is not aligned correctly.

NOTE: If a piston, crankshaft, connecting rod, or block replacement has been performed, the cylinder head gasket may require that it be graded. Refer to Procedure 002-021 in Section 2.

NOTE: Marine applications do **not** use cylinder head gasket grades. Refer to Procedure 002-021 in Section 2.

Install the cylinder head gasket. Refer to Procedure 002-021 in Section 2.

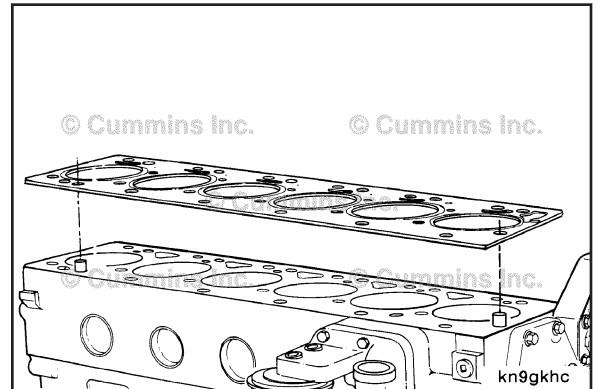

⚠WARNING⚠

This component weighs 23 kg [50 lb] or more. To reduce the possibility of personal injury, use a hoist or get assistance to lift this component.

Carefully put the cylinder head on the cylinder block and seat it onto the dowels.

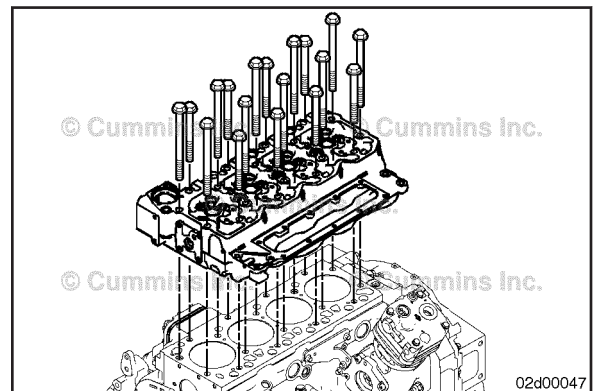

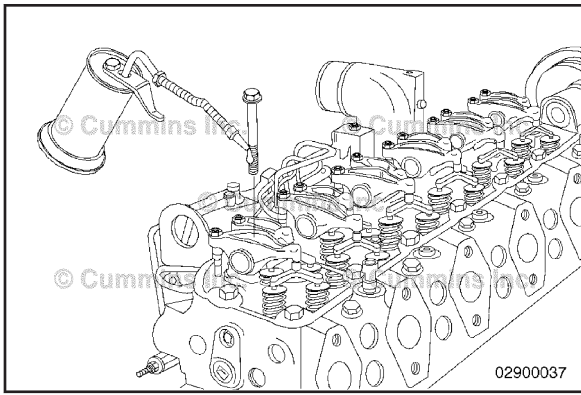

NOTE: If equipped with different length capscrews, the short bolts, 130 mm, are located in the outboard set of holes closest to the intake and exhaust ports. There are eight on the four-cylinder and twelve on the six-cylinder engines.

Lubricate the threads and under the heads on the cylinder head mounting capscrews with clean engine oil.

Install the capscrews and tighten finger-tight.

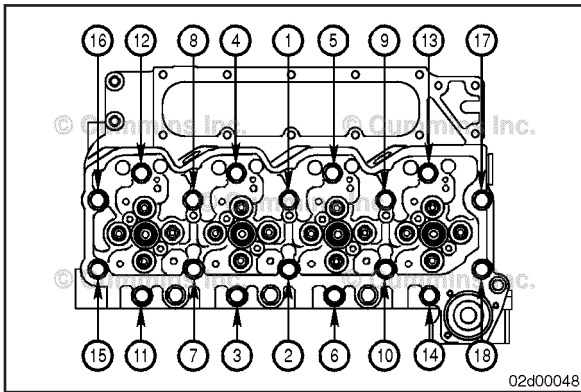

3.9L Engines

NOTE: If equipped with different length capscrews, the short bolts, 130 mm, are located in the outboard set of holes closest to the intake and exhaust ports. There are eight on the four-cylinder and twelve on the six-cylinder engines.

Use the illustrated sequence to tighten the cylinder head capscrews.

Tighten the capscrews.

3.9L Engine - Cylinder Head Torque Values			
Step	Capscrews	N•m	ft-lb
1	All capscrews	35	26
2	Inboard long capscrews only	55	41
3	All capscrews	Rotate 90-degrees clockwise	
4	All capscrews	Rotate 90-degrees clockwise	

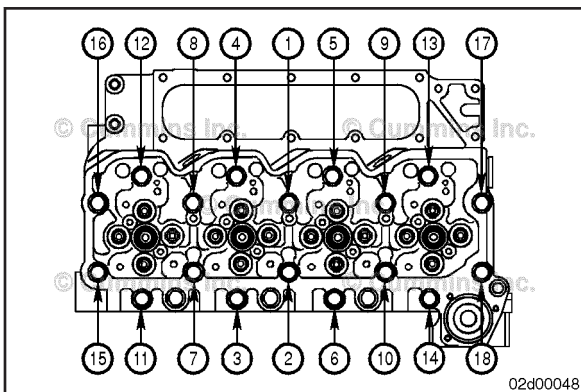

4.5L Engines

Use the illustrated sequence to tighten the cylinder head capscrews.

Tighten the capscrews.

4.5L Engine - Cylinder Head Torque Values			
Step	Capscrews	N•m	ft-lb
1	All capscrews	90	66
2	All capscrews	90	66
3	All capscrews	Rotate 90-degrees clockwise	

5.9 L Engines with Unequal Length Cylinder Head Capscrews



NOTE: If equipped with different length capscrews, the short bolts, 130 mm, are located in the outboard set of holes closest to the intake and exhaust ports. There are eight on the four-cylinder and twelve on the six-cylinder engines.

Use the illustrated sequence to tighten the cylinder head capscrews.

Tighten the capscrews.

5.9L Engines with Unequal Length Cylinder Head Capscrews - Cylinder Head Torque Values			
Step	Capscrews	N•m	ft-lb
1	All capscrews	35	26
2	Inboard long capscrews only	55	41
3	All capscrews	Rotate 90-degrees clockwise	
4	All capscrews	Rotate 90-degrees clockwise	

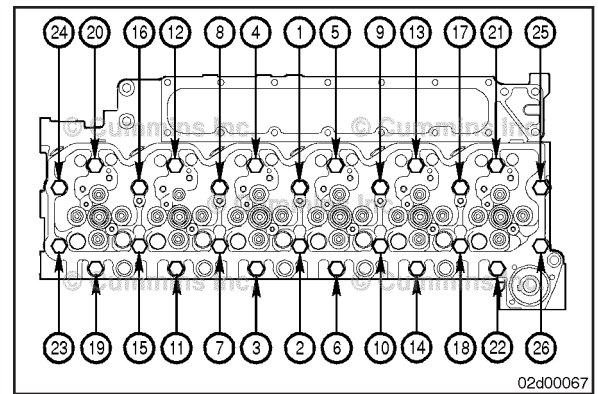

02d00067

5.9 L and 6.7 L Engines with Equal Length Cylinder Head Capscrews



Use the illustrated sequence to tighten the cylinder head capscrews.

Tighten the cylinder head capscrews.

5.9L and 6.7L Engines with Equal Length Cylinder Head Capscrews - Cylinder Head Torque Values			
Step	Capscrews	N•m	ft-lb
1	All capscrews	90	66
2	All capscrews	90	66
3	All capscrews	Rotate 90-degrees clockwise	

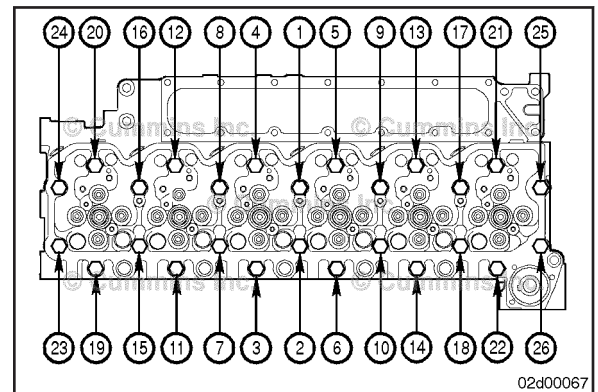

02d00067

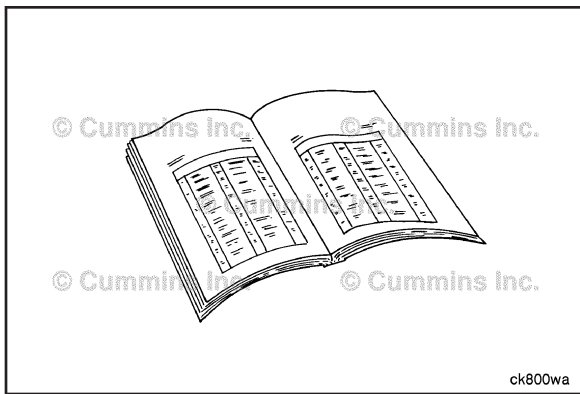

Finishing Steps

Automotive and Industrial

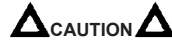

If the cylinder head was installed with the injectors installed, it may be necessary to loosen the injector to correctly install the fuel connectors. Failure to install the fuel connectors will result in excessive injector fuel leakage and poor engine performance.

Install the fuel connectors (Head Mounted). Refer to Procedure 006-052 in Section 6.

Install the fuel rail to the cylinder head. Refer to Procedure 006-060 in Section 6.

Install the injector supply lines (High Pressure). Refer to Procedure 006-051 in Section 6.

Install the fuel drain lines. Refer to Procedure 006-013 in Section 6.

Install the push rods. Refer to Procedure 004-014 in Section 4.

Install the rocker lever assemblies and crossheads. Refer to Procedure 003-008 in Section 3 and Refer to Procedure 002-001 in Section 2.

Adjust the overhead. Refer to Procedure 003-004 in Section 3.

If equipped, install the rocker lever housing. Refer to Procedure 003-013 in Section 3.

Install the rocker lever cover gasket and rocker lever cover. Refer to Procedure 003-011 in Section 3.

Install the exhaust manifold. Refer to Procedure 011-007 in Section 11.

Install the turbocharger. Refer to Procedure 010-033 in Section 10.

NOTE: Omit the following step if the engine is **not** equipped with EGR.

Connect the EGR valve and coolant lines, if equipped. Refer to Procedure 011-022 and Refer to Procedure Procedure 011-030 in Section 11.

If equipped, install the exhaust pressure sensor with the exhaust pressure sensor plumbing. Refer to Procedure 011-027 in Section 11.

Install the EGR cooler and coolant lines. Refer to Procedure 011-019 and Refer to Procedure 011-031 in Section 11.

Install the EGR connection tubes. Refer to Procedure 011-024 and Refer to Procedure 011-025 in Section 11.

NOTE: Omit the following steps if the engine is not equipped with the component or if it was **not** necessary to remove the component to remove the cylinder head.

Use the following procedure to install the coolant temperature sensor in the ISB, ISBe2, ISBe3, ISBe4, QSB4.5, QSB5.9, QSB6.7, ISC, QSC8.3, ISL, ISLe3, ISLe4, and QSL9 CM850 Electronic Control System Troubleshooting and Repair Manual, Bulletin 4021416. Refer to Procedure 019-019 in Section 19.

Install the thermostat housing and thermostat from the engine. Refer to Procedure 008-013 in Section 8.

Install the alternator bracket to the thermostat housing. Refer to Procedure 013-003 in Section 13.

Pivot the alternator towards the engine. Tighten the alternator link, mounting bolt, and water inlet connection capscrews. Refer to Procedure 013-001 in Section 13.

Install the fan hub assembly. Refer to Procedure 008-036 in Section 8.

Install the fan hub pulley. Refer to Procedure 008-039 in Section 8.

Install the drive belt. Refer to Procedure 008-002 in Section 8.

Install the air intake manifold. Refer to Procedure 010-023 in Section 10.

Install the air intake connection and starting aid, if equipped. Refer to Procedure 010-080 in Section 10.

Install the fuel filter and fuel filter head. Refer to Procedure 006-017 in Section 6.

NOTE: The follow components are required to be installed in order to complete the installation of the cylinder head.



WARNING
Coolant is toxic. Keep away from children and pets. If not reused, dispose of in accordance with local environmental regulations.



WARNING
Do not remove the pressure cap from a hot engine. Wait until the coolant temperature is below 50 C [120 F] before removing the pressure cap. Heated coolant spray or steam can cause personal injury.

Connect the air crossover connection. Refer to Procedure 010-019 in Section 10.

Connect all water and heater hoses attached to the cylinder head. Refer to Procedure 008-045 in Section 8.

Install any OEM accessories attached to the cylinder head. Refer to the OEM service manual.

Fill the engine with coolant. Refer to Procedure 008-018 in Section 8.

⚠ WARNING ⚠

Batteries can emit explosive gases. To reduce the possibility of personal injury, always ventilate the compartment before servicing the batteries. To reduce the possibility of arcing, remove the negative (-) battery cable first and attach the negative (-) battery cable last.

Connect the batteries. Refer to the OEM service manual.

Prime the fuel system. Refer to Procedure 005-016 in Section 5.

Operate the engine and check for leaks.

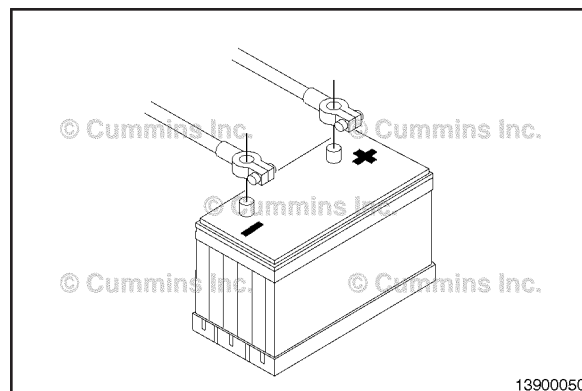

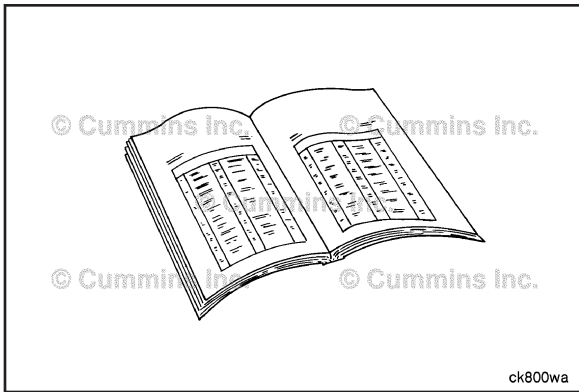

Marine Applications

⚠ WARNING ⚠

Coolant is toxic. Keep away from children and pets. If not reused, dispose of in accordance with local environmental regulations.

⚠ WARNING ⚠

Do not remove the pressure cap from a hot engine. Wait until the coolant temperature is below 50 C [120 F] before removing the pressure cap. Heated coolant spray or steam can cause personal injury.

Install the fuel connectors (head mounted). Refer to Procedure 006-052 in Section 6.

Install the air intake manifold. Refer to Procedure 010-023 in Section 10.

Connect the fuel rail from the cylinder head. Refer to Procedure 006-060 in Section 6.

Install the injector supply lines. Refer to Procedure 006-051 in Section 6.

Install the fuel drain lines. Refer to Procedure 006-013 in Section 6.

Install the push rods. Refer to Procedure 004-014 in Section 4.

Install the rocker levers. Refer to Procedure 003-008 in Section 3.

Install the crossheads. Refer to Procedure 002-001 in Section 2.

Adjust the overhead. Refer to Procedure 003-004 in Section 3.

If equipped, install the rocker lever housing. Refer to Procedure 003-013 in Section 3.

Install the rocker lever cover gasket and rocker lever cover. Refer to Procedure 003-011 in Section 3.

Install the thermostat housing assembly and bracket. Refer to Procedure 008-013 in Section 8.

Install the turbocharger and exhaust manifold as an assembly. Refer to Procedure 011-008 in Section 11.

Install the marine gear oil cooler capscrews. Refer to Procedure 008-041 in Section 8.

Install the closed crankcase breather system. Refer to Procedure 003-020 in Section 3.

Install the sea water pump support. Refer to Procedure 008-058 in Section 8.

Use the following procedure to install the engine coolant temperature sensor in the ISB, ISBe2, ISBe3, ISBe4, QSB4.5, QSB5.9, QSB6.7, ISC, QSC8.3, ISL, ISLe3, ISLe4, and QSL9 CM850 Electronic Control System Troubleshooting and Repair Manual, Bulletin 4021416. Refer to Procedure 019-019 in Section 19.

Install the belt guards. Refer to Procedure 008-001 in Section 8.

Install the aftercooler. Refer to Procedure 010-005 in Section 10.

Install the heat exchanger. Refer to Procedure 008-053 in Section 8.

Install the coolant expansion tank. Refer to Procedure 008-052 in Section 8.

Fill engine coolant. Refer to Procedure 008-018 in Section 8.

⚠ WARNING ⚠

Batteries can emit explosive gases. To reduce the possibility of personal injury, always ventilate the compartment before servicing the batteries. To reduce the possibility of arcing, remove the negative (-) battery cable first and attach the negative (-) battery cable last.

Connect the batteries. Refer to the OEM service manual.

Prime the fuel system. Refer to Procedure 005-016 in Section 5.

Open the sea water valves.

Operate the engine and check for leaks.

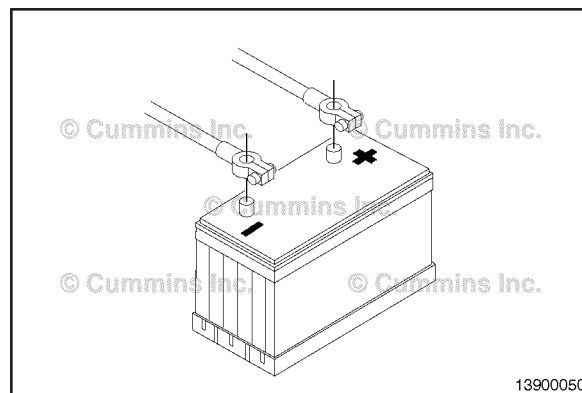

13900050

Valve Guide Seal, Cylinder Head (002-016)

General Information

The following procedure is for removing the valve stem seals with the cylinder head installed. For removing the valve stem seals with the cylinder head removed, Refer to Procedure 002-004

NOTE: This procedure can also be used for removing valve springs, valve spring retainers and valve collets with the cylinder head installed.

For the engines covered by this procedure, different types and color valve stem seals are used. When replacing the valve stem seals, always replace like parts.

There are two types and colors of valve stem seals used:

- "Drive-On Seal"

Colors Used:

- Green (Used for exhaust valves)
- Yellow (Used for intake valves).
- "Top-Hat" Seal

Colors Used:

- Green (Used for exhaust valves)
- Yellow (Used for intake and exhaust valves).

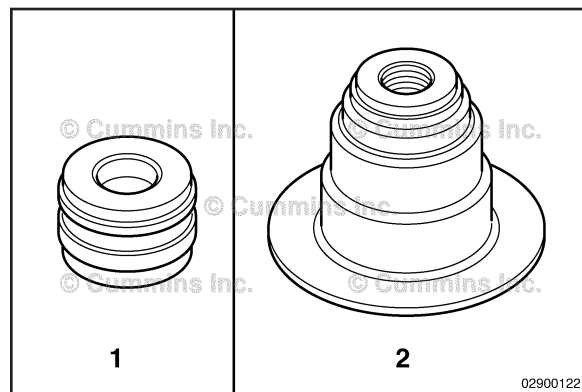

02900122

Preparatory Steps

⚠ WARNING ⚠

Batteries can emit explosive gases. To reduce the possibility of personal injury, always ventilate the compartment before servicing the batteries. To reduce the possibility of arcing, remove the negative (-) battery cable first and attach the negative (-) battery cable last.

- Disconnect the batteries. Refer to Procedure 013-009
- Remove the rocker lever cover. Refer to Procedure 003-011

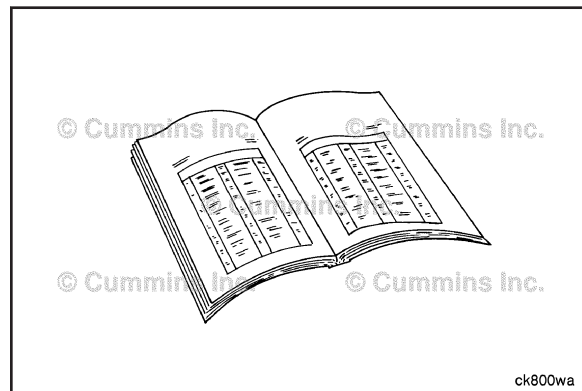

ck800wa

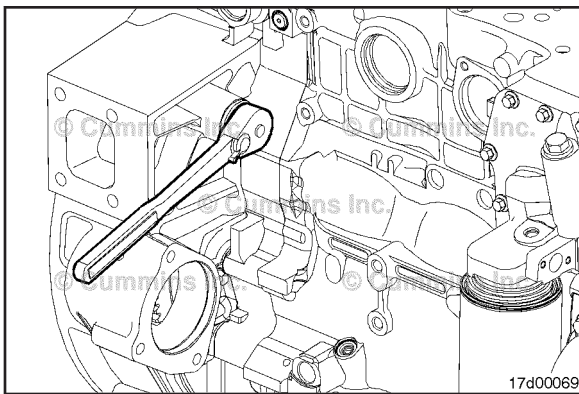

Remove

NOTE: In order to remove the valve springs with the cylinder head installed, the piston of the cylinder being worked on **must** be brought to TDC to support the valves.

Use the barring tool, Part Number 3824591, rotate the piston to the top dead center on the cylinder being worked on.

TDC can be determined by the following methods:

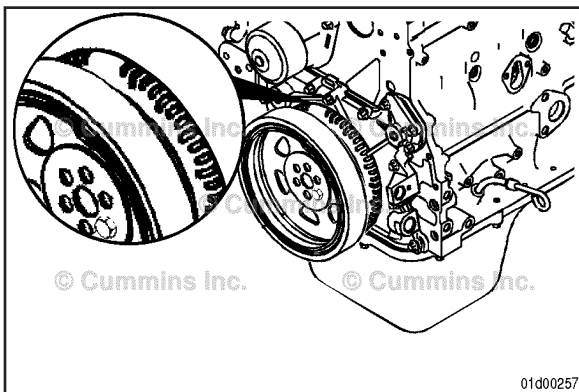

For 3.9L and 5.9L Engines without EGR (except Marine applications):

Align the crankshaft speed indicator ring on the front of the crankshaft so that the unpunched area of the crankshaft speed indicator ring is at the 12-o'clock position. If both number 1 cylinder rocker levers are loose, move to the following steps. If both number 1 cylinder rocker levers are **not** loose, rotate the crankshaft 360 degrees.

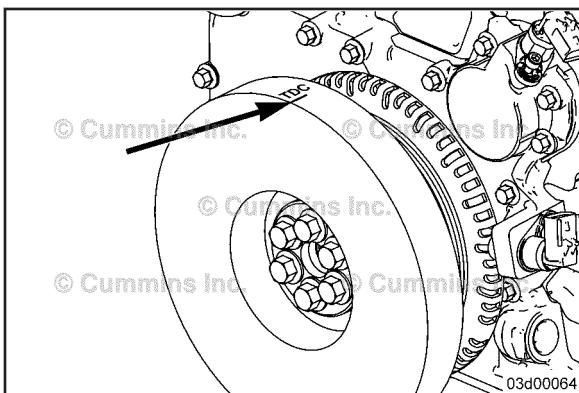

For all 4.5L, 5.9L engines with EGR, 5.9L engines used in Marine Applications, and 6.7L engines.

NOTE: The TDC mark is on the vibration damper/crankshaft speed indicator ring. Do **not** use the open window in the crankshaft speed indicator ring as TDC indication.

Align the vibration damper/crankshaft speed indicator ring so that the TDC mark is at the 12-o'clock position. If both number 1 cylinder rocker levers are loose, move to the following steps. If both number 1 cylinder rocker levers are **not** loose, rotate the crankshaft 360 degrees.

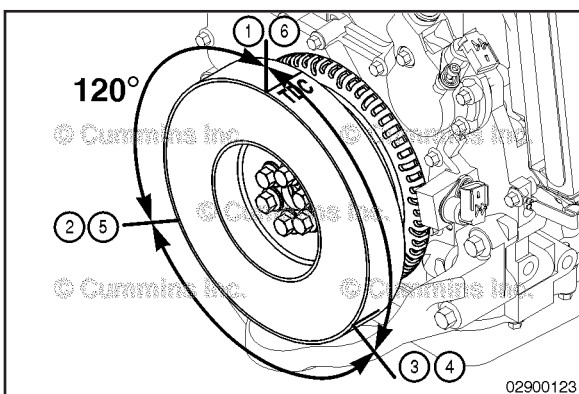

With the vibration damper/crankshaft speed indicator ring at TDC for the number 1 cylinder, mark the damper for the location of TDC for the other cylinders.

For six cylinder engines:

- Mark the vibration damper every 120 degrees with a marker directly on the damper or to a piece of masking tape applied directly around the damper.

Service Tip: A protractor, camshaft degree wheel or angle/level indicator, Part Number 3375855, can be used to locate 120 degree increments around the vibration damper/crankshaft speed indicator ring.

- Mark the damper with the TDC indicator for each cylinder as shown. Two cylinders correspond to each 120-degree line.

For four cylinder engines:

- Mark the vibration damper every 180 degrees with a marker directly on the damper or to a piece of masking tape applied directly around the damper.

Service Tip: A protractor, camshaft degree wheel or angle/level indicator, Part Number 3375855, can be used to locate 180 degree increments around the vibration damper/crankshaft speed indicator ring.

- Mark the damper with the TDC indicator for each cylinder as shown. Two cylinders correspond to each 180-degree line.

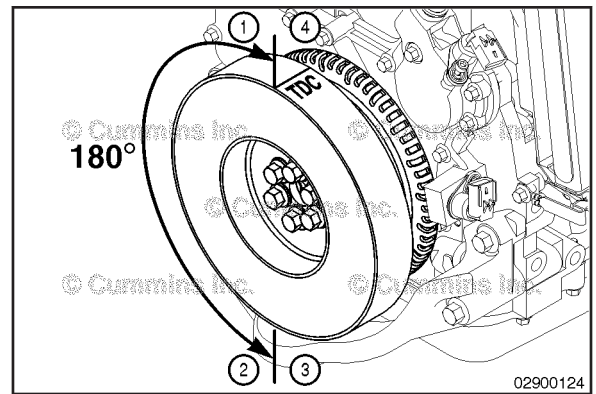

Remove all the rocker lever assemblies and crossheads. Refer to Procedure 003-008 and Procedure Refer to Procedure 002-001

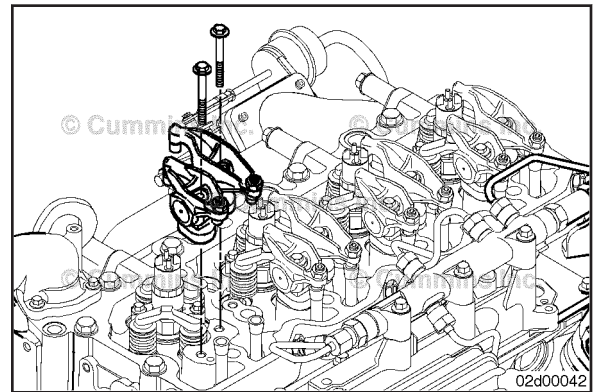

Remove all of the injectors. Refer to Procedure 006-026

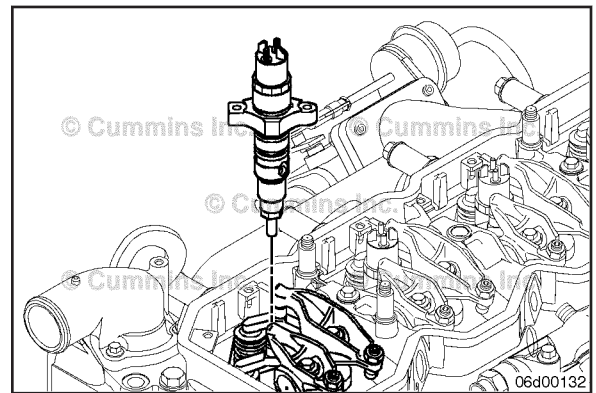

Compress the valve springs. Use the valve spring compressor, Part Number 3164329.

Position the replacer screw (4) above the injector bore and install the two capscrews (5) in the cylinder head where the hold-down clamp screws were removed.

Tighten the capscrews (5).

Torque Value: 5 N•m [44 in-lb]

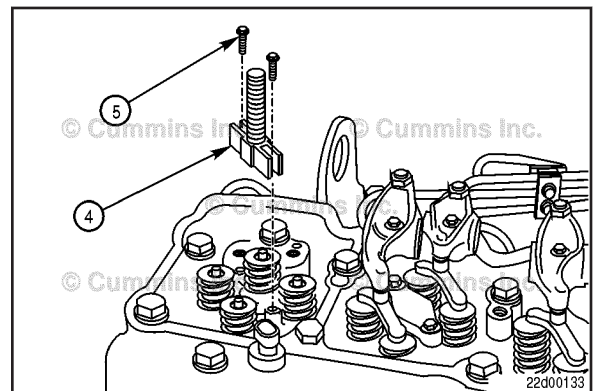

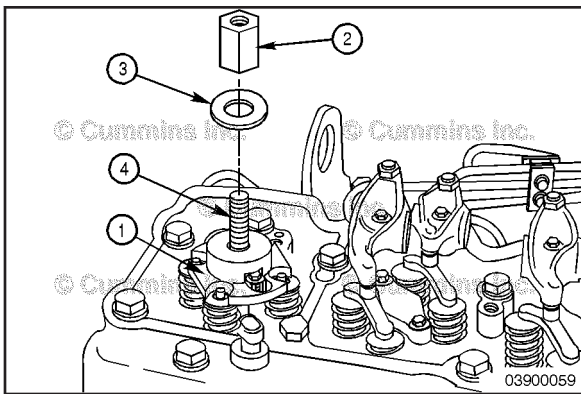

NOTE: The valves are **not** evenly spaced from the injector bore. It is important to align the slots in the valve spring compressor plate with the valve springs.

Apply anti-seize lubricant to the replacer screw (4) threads. **Always** read and follow label precautions.

Position the valve spring compressor plate (1) on the replacer screw (4) and align the slots in the valve spring compressor plate with the valve springs.

Install the washer (3) and nut (2) on the replacer screw (4).

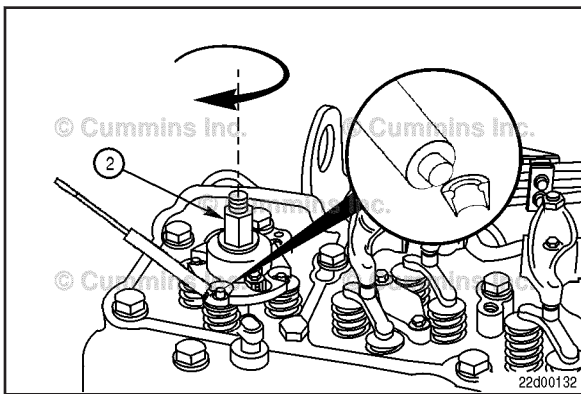

WARNING

Valve springs are under tension and can act as projectiles if released. To reduce the possibility of eye injury, wear safety glasses with side shields.

Turn the nut (2) **clockwise** to compress the valve springs.

Continue turning the nut (2) **clockwise** until the valve collets can be removed using a magnetic tool, such as the end of a magnetic screwdriver.

NOTE: Because there is a gap between the top of the piston and the valve face, it may be necessary to use a second magnet to hold the valve stem up to remove the valve collets.

Remove the valve collets and the valve spring compressor service tool.

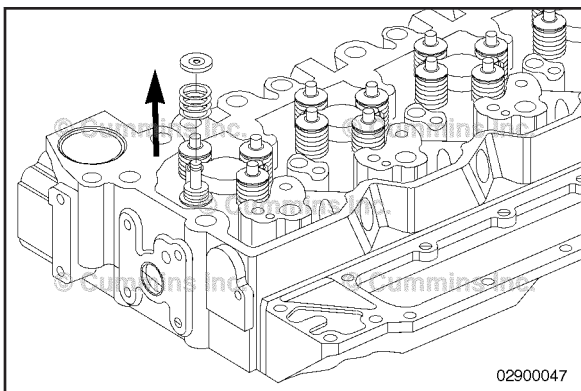

CAUTION

With the valve collets, valve springs, and valve spring retainers removed, do not rotate the engine. Rotating the engine will allow the valves to drop into the cylinder requiring the cylinder head to be removed or possible engine damage.

Remove the four valve spring retainers and valve springs.

NOTE: Prior to removing the valve stem seals, note the type and color of the valve stem seal installed at each valve location. The same type and color valve stem seal **must** be installed when assembling the cylinder head.



There are two types and colors of valve stem seals used:

- "Drive-On Seal"

Colors Used:

- Green (Used for exhaust valves)
- Yellow (Used for intake valves).
- "Top-Hat" Seal

Colors Used:

- Green (Used for exhaust valves)
- Yellow (Used for intake and exhaust valves).

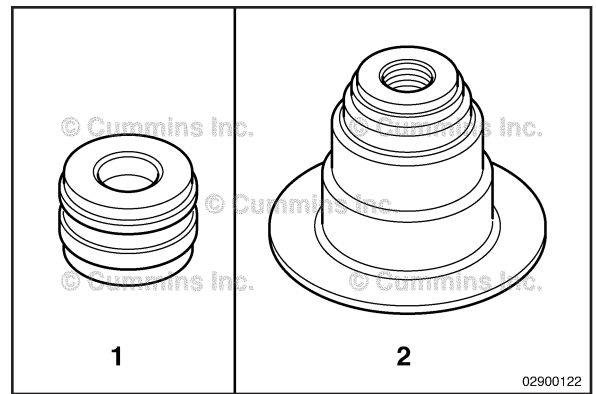

Use boot pliers, Part Number 3163293, to remove the valve stem seals.



NOTE: The valve stem seals can be installed by hand. The installation tool will aid with installing the valve stem seals, but is **not** mandatory.

Note the type, color and location of the seal, then discard the old seal.

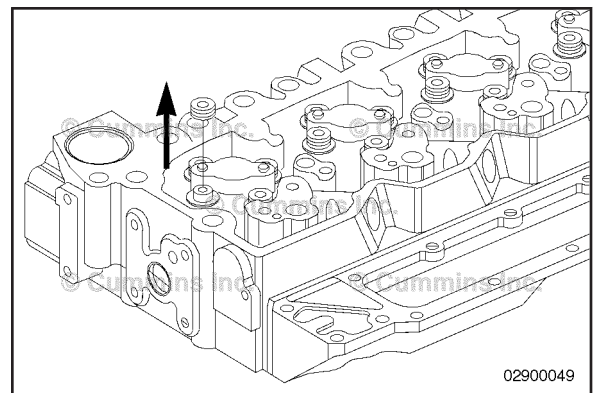

Clean and Inspect for Reuse

Clean the seal tower and valve stem with contact cleaner, Part Number 3824510.

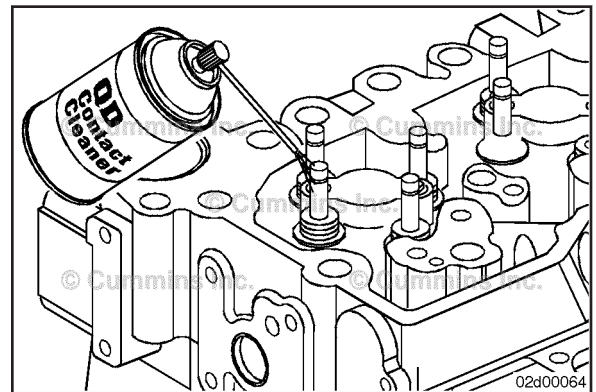

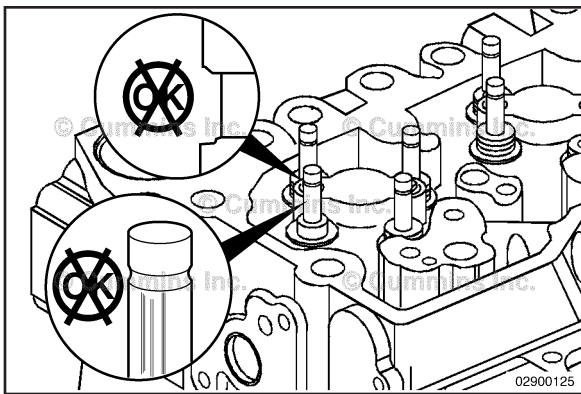

Inspect the exposed valve stem for scoring or heavy polishing. Inspect the valve collet grooves for wear.

If the valve stem is damaged, the cylinder head **must** be removed and the valve replaced. Refer to Procedure 002-004

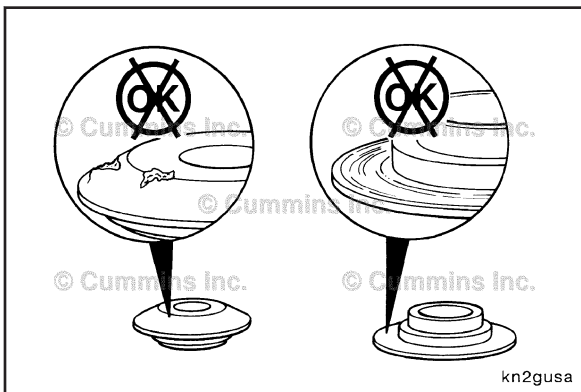

Inspect the valve spring retainers and valve collets for damage or worn areas.

Discard and replace damaged and worn parts.

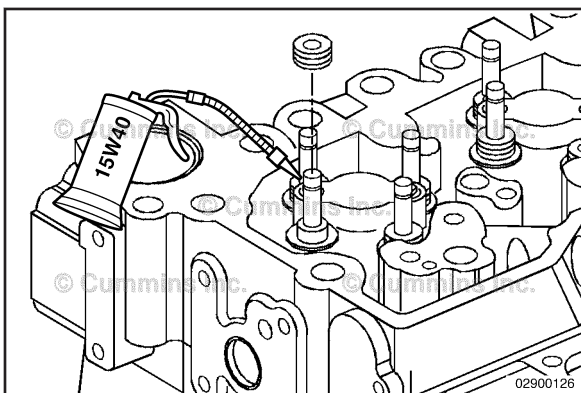

Install

⚠CAUTION⚠

The same type and color valve stem seal must be installed in the same location as removed. Incorrect valve stem seals will result in excessive oil consumption and internal engine damage.



⚠CAUTION⚠

Lubricate all the valve guide bores and valve stems with SAE 15W-40 engine oil. Failure to lubricate the valve guides and valve stems can result in premature valve guide wear.

Install new valve stem seals of the same type and color as removed and in the same location. See the General Information section of this procedure for valve stem seal identification.

Lubricate the stems with SAE 15W-40 engine oil before installing the valve stem seals.

Install new valve stem seals. Use a valve stem installation tool, Part Number 3164055.

Install the valve spring retainer and valve springs.

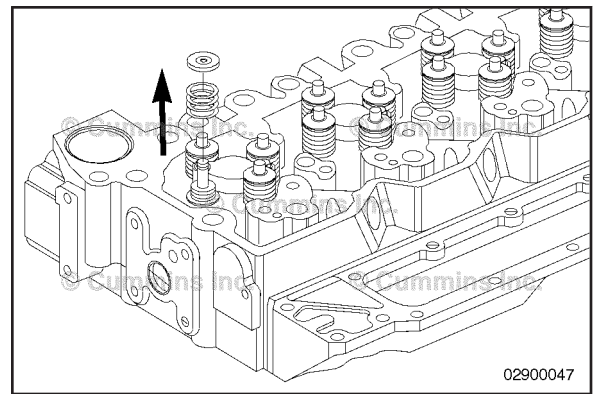

Compress the valve springs using the valve spring compressor, Part Number 3164329.

Position the replacer screw (4) above the injector bore and install the two capscrews (5) in the cylinder head where the hold-down clamp screws were removed.

Tighten the capscrews (5).

Torque Value: 5 N•m [44 in-lb]

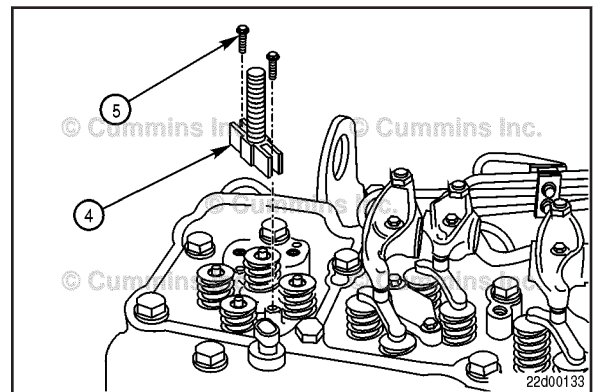

NOTE: The valves are **not** evenly spaced from the injector bore. It is important to align the slots in the valve spring compressor plate with the valve springs.

Apply anti-seize lubricant to the replacer screw (4) threads. **Always** read and follow label precautions.

Position the valve spring compressor plate (1) on the replacer screw (4) and align the slots in the valve spring compressor plate with the valve springs.

Install the washer (3) and nut (2) on the replacer screw (4).

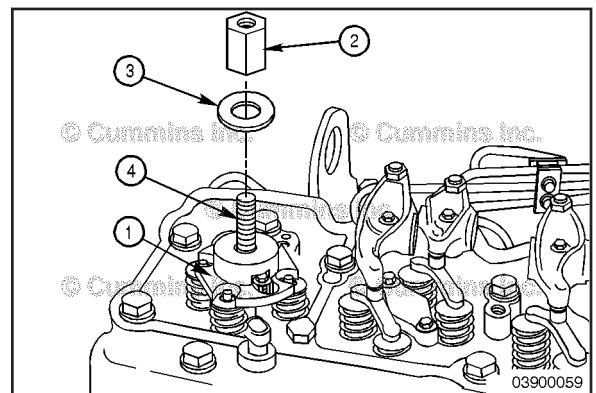

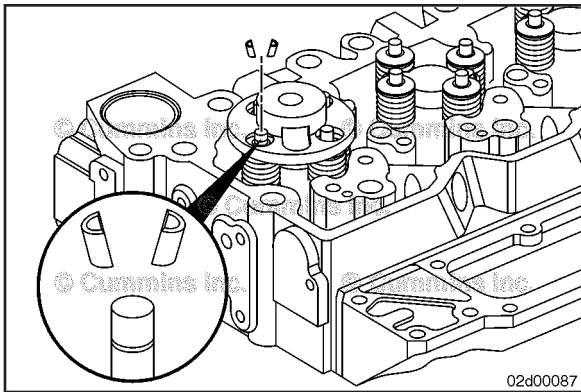

⚠ WARNING ⚠

Valve springs are under tension and can act as projectiles if released. To reduce the possibility of eye injury, wear safety glasses with side shields.

NOTE: Because there is a gap between the top of the piston and the valve face, it may be necessary to use a second magnet to pull the valve stem up to remove the valve collets.

Compress the valve springs until the valve collets can be installed.

Install the valve collets.

Service Tip: Use Assembly Lube, Part Number 3163087 or equivalent, on the valve collets to help hold them in place until the valve spring compressor is released.

Remove the valve spring compressor service tool.

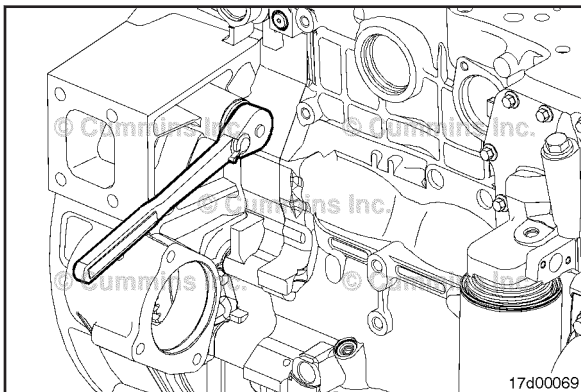

Use the marks made previously on the vibration damper/crankshaft speed indicator, rotate the engine **clockwise** to put the next group of cylinders at TDC.

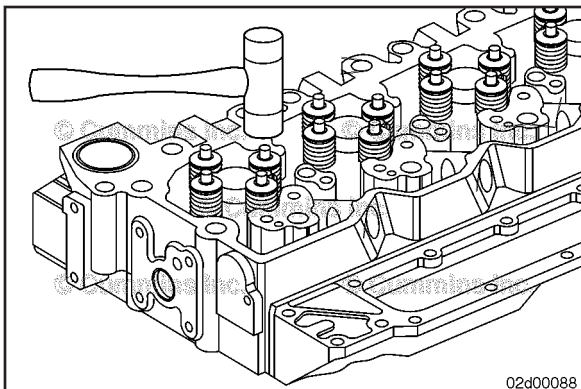

⚠ WARNING ⚠

To reduce the possibility of personal injury, wear eye protection. If the collets are not correctly installed, they can fly out when the stems are hit with a hammer.

⚠ CAUTION ⚠

Rotate the engine to the next cylinder in the firing order before hitting the valve stem of the cylinder previously worked on. This will ensure that the valve does not contact the piston, resulting in a bent valve and internal engine damage.

After rotating the engine to the next group of cylinders, hit the valve stems of the cylinders previously worked on with a plastic hammer to make sure the collets are seated.

Repeat the previous steps until all of the valve stem seals are replaced.

Finishing Steps

⚠ WARNING ⚠

Batteries can emit explosive gases. To reduce the possibility of personal injury, always ventilate the compartment before servicing the batteries. To reduce the possibility of arcing, remove the negative (-) battery cable first and attach the negative (-) battery cable last.

- Install the injectors. Refer to Procedure 006-026
- Install the rocker lever assemblies and cross heads. Refer to Procedure 003-008 and Procedure Refer to Procedure 002-001
- Adjust the overhead. Refer to Procedure 003-004
- Install the rocker lever cover. Refer to Procedure 003-011
- Connect the batteries. Refer to Procedure 013-009
- Operate the engine and check for leaks.

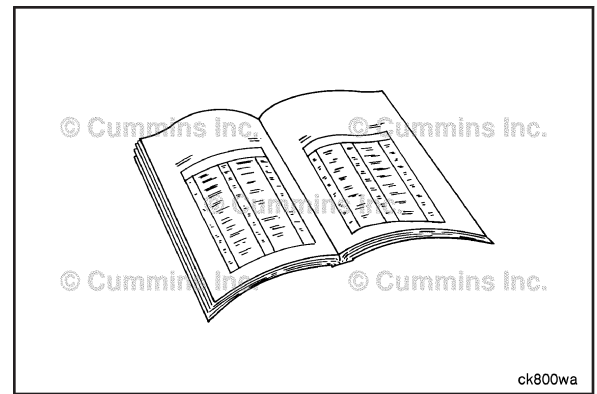

Cylinder Head Gasket (002-021)

General Information

4.5L and 6.7L engines do **not** have graded gaskets. QSB5.9 Marine engines also do **not** have graded gaskets. Use like part numbers.

3.9L and 5.9L engines have graded gaskets. There are also service gaskets available for 5.9L engines with EGR when oversize pistons or a repair sleeve is installed. Measure piston protrusion to determine which grade to use.

No specific cylinder head gasket with an increased thickness is available for combustion deck resurfacing of the cylinder block or cylinder head. If the combustion deck can **not** be resurfaced such that the correct specifications can be maintained, the block and/or cylinder head **must** be replaced.

Remove and install instructions and specifications can be found in the following procedures:

- Refer to Procedure 001-026 in Section 1.
- Refer to Procedure 002-004 in Section 2.

Preparatory Steps

⚠ WARNING ⚠

This assembly weighs greater than 23 kg [50 lb] . To prevent serious personal injury, be sure to have assistance or use the appropriate lifting equipment to lift this component or assembly.

Remove the cylinder head. Refer to Procedure 002-004 in Section 2

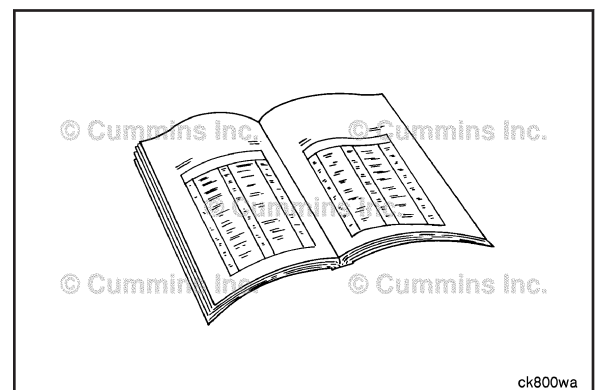

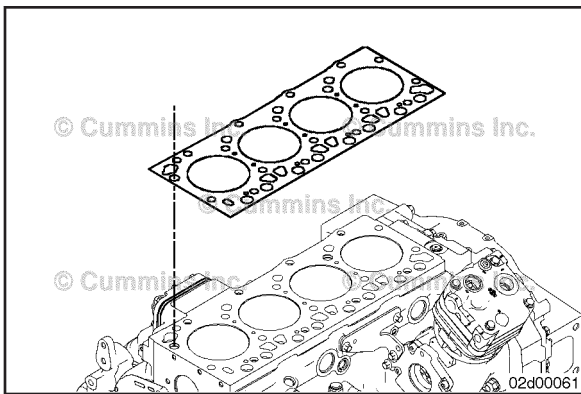

Remove

Remove the cylinder head gasket.

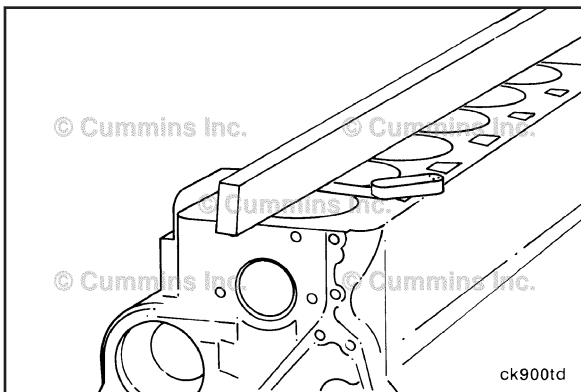

Clean and inspect for reuse

NOTE: Cylinder head gaskets can **not** be reused. A new cylinder head gasket **must** be used.



Clean the cylinder block and cylinder head combustion deck. Inspect and measure the cylinder block and cylinder head combustion deck flatness. Refer to Procedure 002-004 in Section 2

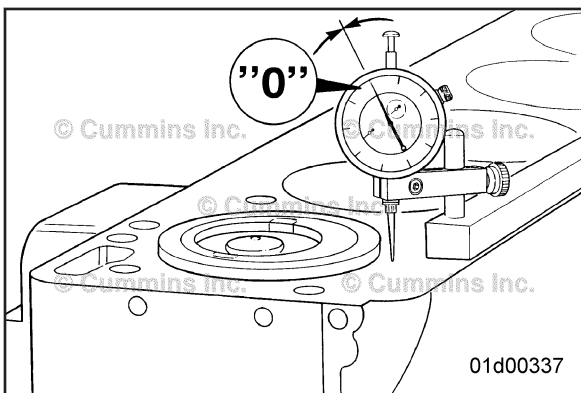

Measure

For engines requiring cylinder head gasket grading, measure piston protrusion.

NOTE: This procedure is only required after a piston, crankshaft, connecting rod, or block replacement. Otherwise, use the same grade gasket that was previously installed.

4.5L, 6.7L, and QSB5.9L Marine engines do **not** use graded gaskets.

Install depth gauge assembly, Part Number 3164438, on the block combustion deck and zero the gauge.

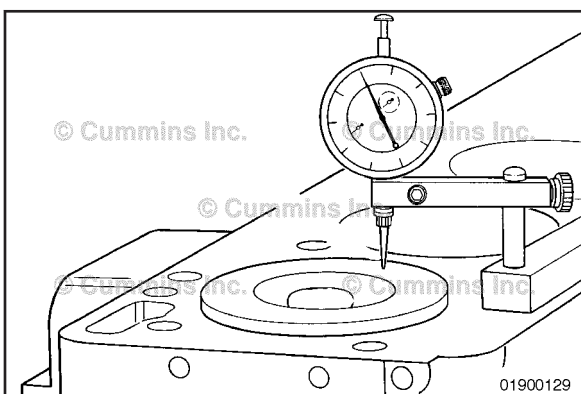

Use a barring tool, Part Number 3824591, to rotate the crankshaft to top dead center.

Move the dial indicator directly over the piston pin to eliminate any side-to-side movement.

Rotate the crankshaft **clockwise** and **counterclockwise** to find the highest dial indicator reading.

Record the reading.

Repeat on the remaining cylinders.

Calculate the average height by adding all numbers recorded and dividing by the number of cylinders.

Record the number calculated. This number will be used to determine which grade of cylinder head gasket to use.

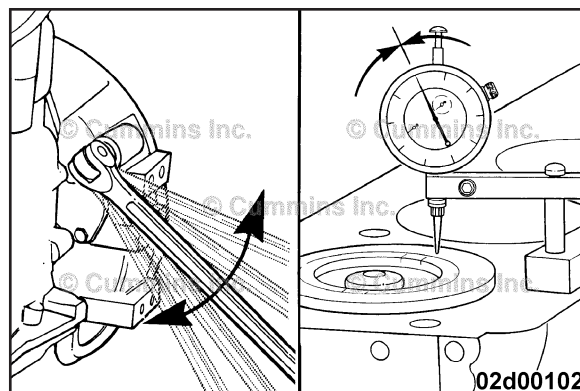

Each graded cylinder head gasket has a grade identification tab that indicates the thickness of the cylinder head gasket, thick or thin.

The location of the tab will vary according to the type of engine.

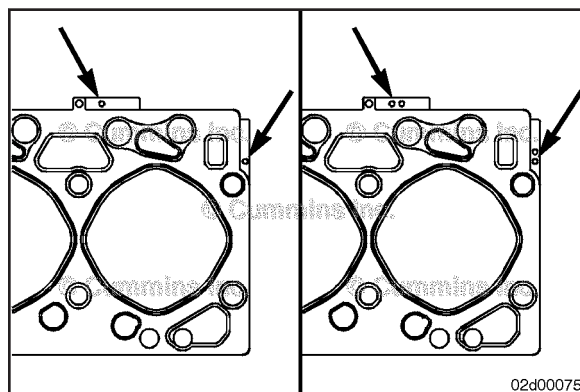

⚠ CAUTION ⚠

The cylinder head gaskets for 5.9 L engines without EGR and 5.9 L engines with EGR with oversize pistons or repair sleeve may visually appear similar, but the cylinder head gaskets can not be interchanged. Engine damage will result.

3.9L and 5.9L engines without EGR will have the grade identification tab on the exhaust side of the cylinder head gasket between cylinders 3 and 4 for 4 cylinder engines and between cylinders 5 and 6 for 6 cylinder engines.

5.9L engines with EGR, that have had oversize pistons or repair sleeves installed, will also have the identification tab on the exhaust side between cylinders 5 and 6.

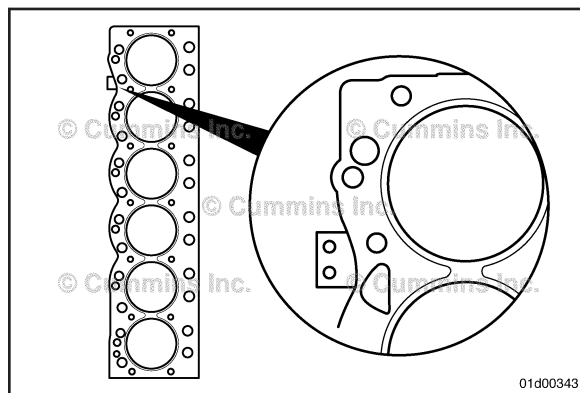

The thickness of the cylinder head gasket can be determined by the location of the holes in the cylinder head gasket grade identification tab. For thin cylinder head gaskets (A), the holes are spaced close together. For thick cylinder head gaskets (B), the holes are more widely spaced.

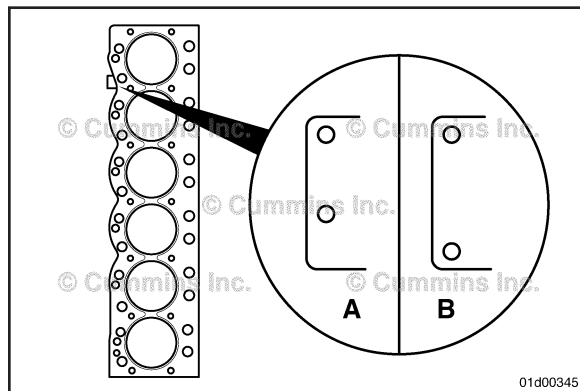

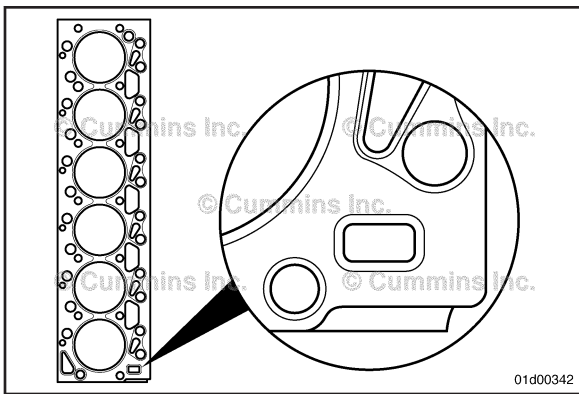

5.9 L engines with EGR have the grade identification tab located on the portion of the cylinder head gasket corresponding to the front of the engine on the intake side.

If a repair sleeve or oversize pistons have been installed, the grade identification tab will be on the exhaust side, as explained previously.

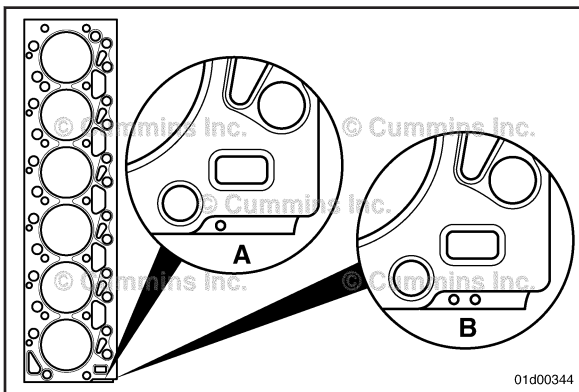

The thickness of the cylinder head gasket can be determined by the number of holes in the cylinder head gasket grade identification tab. There is 1 hole for thin cylinder head gaskets (A). There are 2 holes for thick cylinder head gaskets (B).

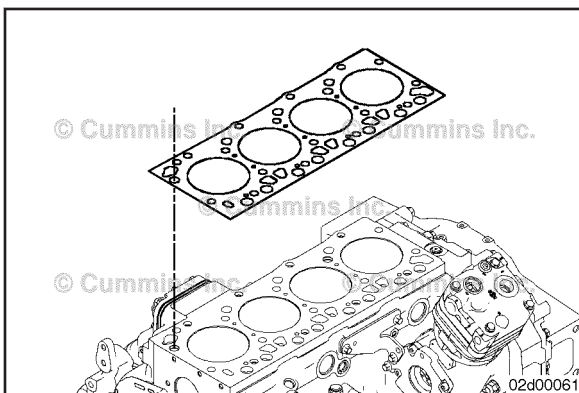

Using the average piston protrusion recorded earlier, determine which cylinder head gasket is needed from the following table:

Head Gasket Determination	
Average Piston Protrusion	Head Gasket Grade
≥ 0.30 mm [0.012 in]	Thick (B)
< 0.30 mm [0.012 in]	Thin (A)

Install

⚠CAUTION⚠

For 5.9 L engines with EGR, when using oversize pistons or repair sleeves a service specific cylinder head gasket must be used to make sure proper sealing of the combustion seal ring is acquired. Failure to use the correct cylinder head gasket can result in engine damage.

Only 5.9L engines with EGR have a service cylinder head gasket available when oversize pistons or repair sleeves are installed. The production cylinder head gasket combustion ring is **not** completely circular. The service gasket has an increased diameter combustion seal. This gasket **must** be used to make sure proper sealing of the combustion seal ring is acquired.

QSB 5.9 Marine 425 engines have a special cylinder head gasket that accommodates this engine's cylinder pressure requirements.

This gasket can be identified by:

- Witness marks at the front edge and front side of the gasket.
- Cummins Inc.'s "C's" printed on the gasket surface in dark blue ink.

QSB5.9 Marine gaskets do **not** have graded gaskets or service gaskets for oversize bores.

A new gasket **must** be installed. Do **not** reuse an old gasket.

Install the cylinder head gasket.

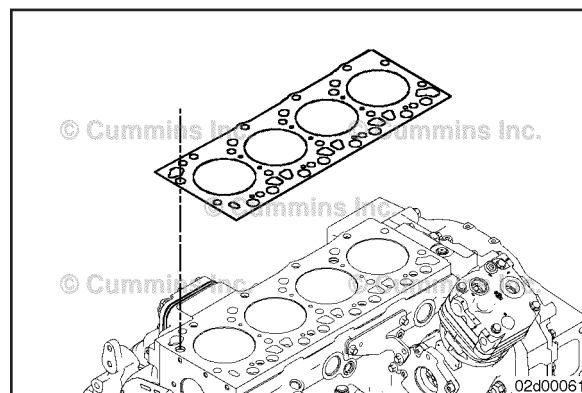
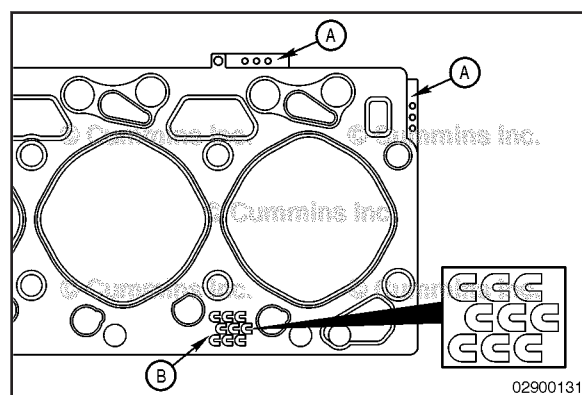
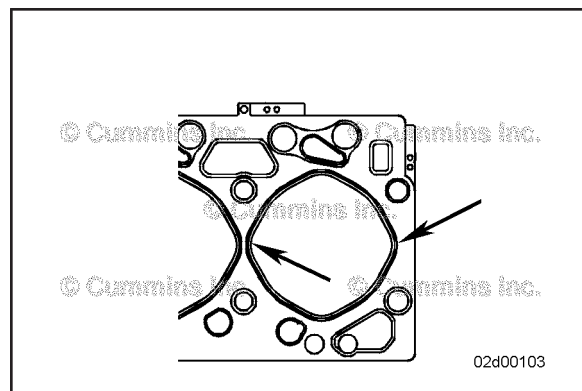

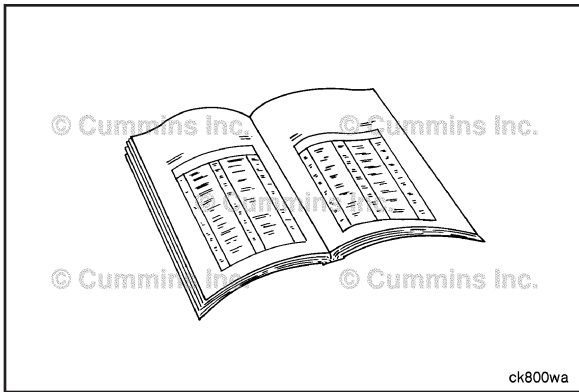

Finishing Steps

▲ WARNING ▲



This assembly weighs greater than 23 kg [50 lb] . To prevent serious personal injury, be sure to have assistance or use the appropriate lifting equipment to lift this component or assembly.

- Install the cylinder head. Refer to Procedure 002-004 in Section 2

Mounting Bracket, Lubricating Oil and Fuel Filter (002-033)

Preparatory Steps

⚠ WARNING ⚠

To reduce the possibility of personal injury, avoid direct contact of hot oil with your skin.

⚠ WARNING ⚠

Some state and federal agencies have determined that used engine oil can be carcinogenic and cause reproductive toxicity. Avoid inhalation of vapors, ingestion, and prolonged contact with used engine oil. If not reused, dispose of in accordance with local environmental regulations.

⚠ WARNING ⚠

Fuel is flammable. Keep all cigarettes, flames, pilot lights, arcing equipment, and switches out of the work area and areas sharing ventilation to reduce the possibility of severe personal injury or death when working on the fuel system.

⚠ WARNING ⚠

Drain the fuel-water separator into a container, and dispose of contents in accordance with local environmental regulations.

⚠ WARNING ⚠

Batteries can emit explosive gases. To reduce the possibility of personal injury, always ventilate the compartment before servicing the batteries. To reduce the possibility of arcing, remove the negative (-) battery cable first and attach the negative (-) battery cable last.

⚠ CAUTION ⚠

Use caution when disconnecting or removing fuel lines, replacing filters and priming the fuel system that fuel is not spilled or drained into the bilge area. Do not drop or throw filter elements into the bilge area. The fuel and fuel filters must be discarded in accordance with local environmental regulations.

- Disconnect the batteries from the engine(s). Refer to Procedure 013-009
- Shut off the fuel supply and return lines.
- Remove the fuel filter. Refer to Procedure 006-015
- Remove the lubricating oil filter. Refer to Procedure 007-037
- Disconnect the lubricating oil lines to the filter head. Refer to Procedure 007-092
- Disconnect the fuel supply and return lines at the fuel filter head. Refer to Procedure 006-024

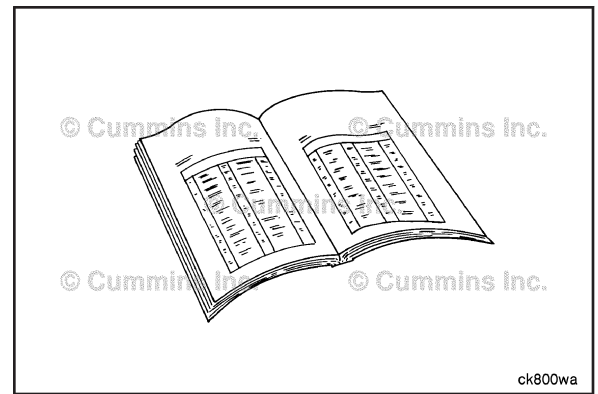

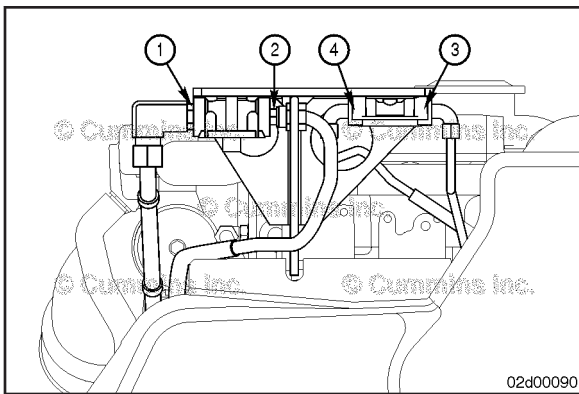

Remove

Loosen, but do **not** remove, the inlet (1) and outlet (2) lubricating oil filter head face seal connection locknuts.

Loosen, but do **not** remove, the inlet (3) and outlet (4) fuel filter head face seal connection locknuts.

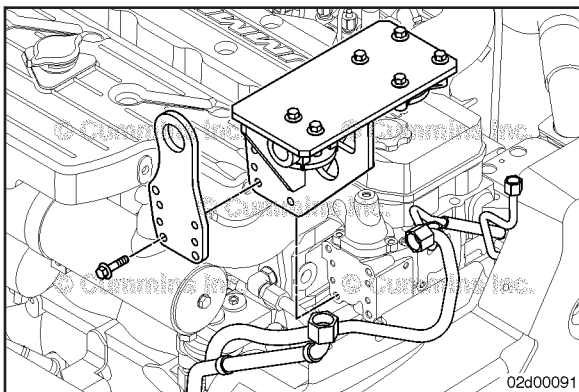

Remove the four mounting capscrews and the filter bracket from the cylinder head.

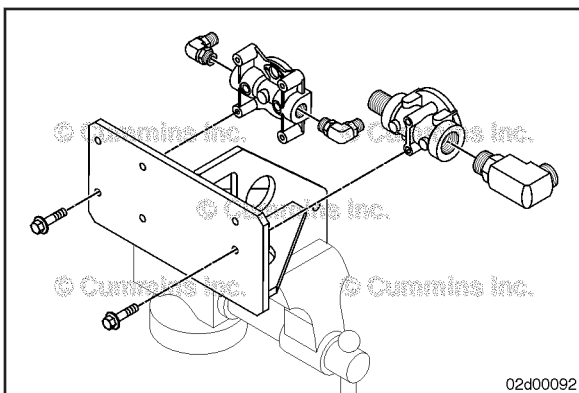

Disassemble

⚠CAUTION⚠

To prevent the possibility of high filter restriction after installation and causing filter damage, be sure to mark the lubricating oil filter head and fuel filter head inlet and outlet ports prior to removal from the bracket. Failure to do so can cause the center filter media to break up and be pumped through the engine.

Place the filter bracket in a vise.

Remove the filter head assemblies from the bracket.

Label the filter head connectors to identify the lubricating oil connections, fuel connections, and fitting orientation.

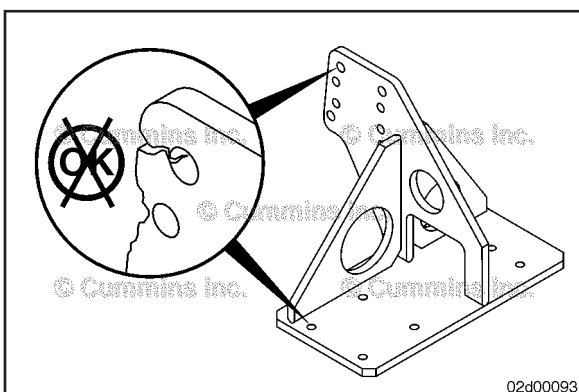

Inspect for Reuse

Inspect the bracket for cracks or damage.

Inspect the fuel head sealing surfaces and bypass, if equipped.

Assemble

Replace the compression o-ring seals and o-rings on all face sealing connections.

Install the inlet and outlet connections into the filter heads. Be sure the lubricating oil or fuel connections are orientated correctly and they are installed to their proper depth. Do **not** torque or tighten the fitting locknuts at this time.

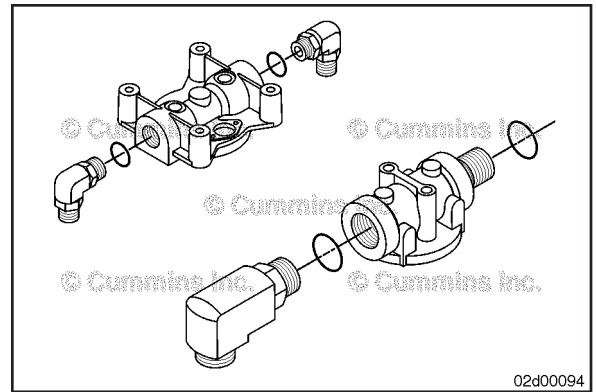

⚠ CAUTION ⚠

To prevent the possibility of high filter restriction after installation and causing filter damage, be sure the lubricating oil filter head and fuel filter head inlet and outlet ports are orientated correctly to the bracket prior to installation. Failure to do so can cause the center filter media to break up and be pumped through the engine.

Install the filter bracket into a vise.

Install the filter head assemblies to the bracket and tighten the capscrews.

Torque Value:

Fuel Filter Head
Step 1 30 N•m [25 ft-lb]

Torque Value:

Lubricating Oil Filter Head
Step 1 18 N•m [160 in-lb]

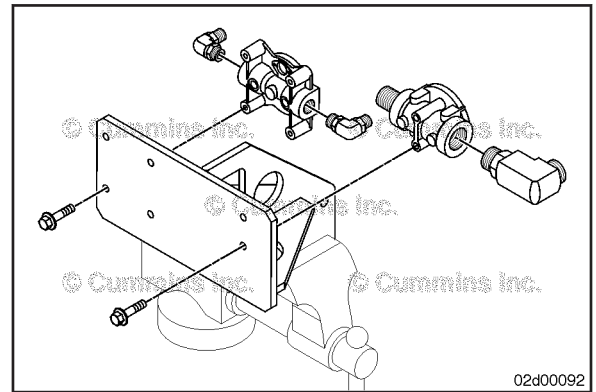

Install

Install the filter mounting bracket on the engine using the four mounting capscrews.

Torque Value: 24 N•m [18 ft-lb]

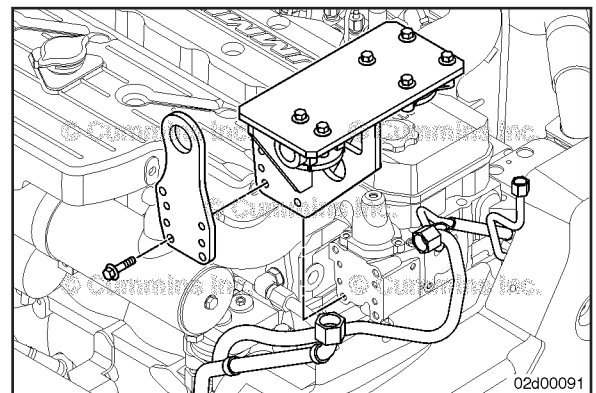

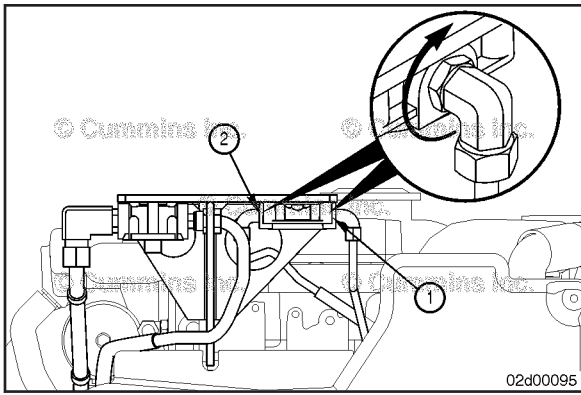

Install the fuel supply and return hoses to the face seal connections.



Tighten the face seal tube nuts finger tight. Be sure the o-rings are in place and properly located.

Tighten the inlet (1) and outlet (2) connection locking nuts against the fuel filter head.

Torque Value: 37 N•m [27 ft-lb]

Tighten the fuel filter inlet and outlet flex tubes.

Torque Value: 37 N•m [27 ft-lb]

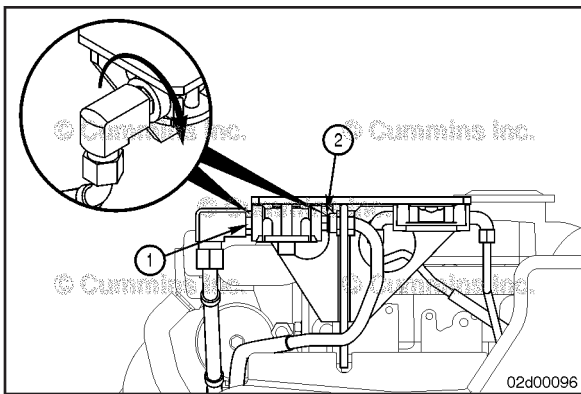

⚠ CAUTION ⚠

When installing the lubricating oil flex hoses, be sure there is proper clearance between the flex hoses and the alternator electrical connections.



Install the lubricating oil filter flex hoses to the face seal connection and tighten the tube nuts finger tight. Be sure the o-rings are in place and properly located.

Tighten the lubricating oil filter inlet (1) and outlet (2) connection locking nuts.

Torque Value: 76 N•m [56 ft-lb]

Tighten the lubricating oil filter inlet and outlet flex hoses to the face connections.

Torque Value: 76 N•m [56 ft-lb]

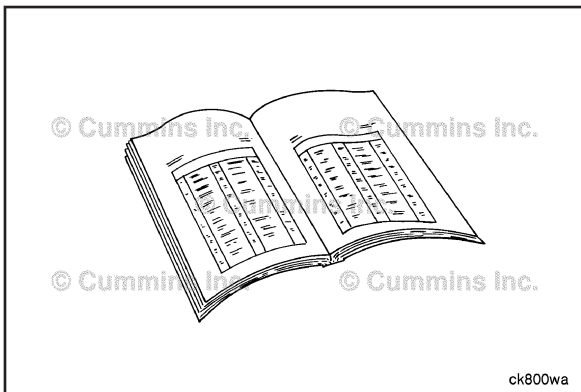

Finishing Steps

⚠ WARNING ⚠

Batteries can emit explosive gases. To reduce the possibility of personal injury, always ventilate the compartment before servicing the batteries. To reduce the possibility of arcing, remove the negative (-) battery cable first and attach the negative (-) battery cable last.

- Install a new fuel filter element. Refer to Procedure 006-015
- Install a new lubricating oil filter. Refer to Procedure 007-037
- Connect the batteries to the engine. Refer to Procedure 013-009
- Open the fuel supply and return lines.
- Prime the fuel system. Refer to Procedure 005-016

Operate the engine and check for leaks.

Section 3 - Rocker Levers - Group 03

Section Contents



	Page
Closed-Crankcase Ventilation System Filter	3-38
Clean and Inspect for Reuse.....	3-39
Finishing Steps.....	3-40
Initial Check.....	3-38
Install.....	3-40
Preparatory Steps.....	3-38
Remove.....	3-38
Crankcase Breather (External)	3-2
Clean and Inspect for Reuse.....	3-3
Finishing Steps.....	3-5
General Information.....	3-2
Install.....	3-4
Preparatory Steps.....	3-2
Remove.....	3-2
Crankcase Breather (Internal)	3-5
Clean and Inspect for Reuse.....	3-8
Finishing Steps.....	3-11
General Information.....	3-5
Install.....	3-9
Preparatory Steps.....	3-5
Remove.....	3-6
Crankcase Breather Tube	3-33
Clean and Inspect for Reuse.....	3-35
Finishing Steps.....	3-37
General Information.....	3-33
Install.....	3-36
Preparatory Steps.....	3-33
Remove.....	3-34
Overhead Set	3-12
Adjust.....	3-13
Finishing Steps.....	3-16
General Information.....	3-12
Preparatory Steps.....	3-12
Rocker Lever	3-16
Assemble.....	3-20
Clean and Inspect for Reuse.....	3-18
Disassemble.....	3-17
Finishing Steps.....	3-22
Install.....	3-21
Preparatory Steps.....	3-16
Remove.....	3-17
Rocker Lever Cover	3-23
Assemble.....	3-27
Clean and Inspect for Reuse.....	3-26
Disassemble.....	3-25
Finishing Steps.....	3-30
General Information.....	3-23
Install.....	3-28
Preparatory Steps.....	3-23
Remove.....	3-23
Rocker Lever Housing	3-31
Clean.....	3-32
Inspect for Reuse.....	3-32
Install.....	3-32
Remove.....	3-31
Service Tools	3-1
Rocker Levers.....	3-1

This Page Left Intentionally Blank

Service Tools

Rocker Levers

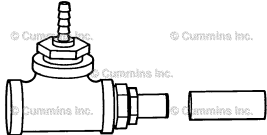
The following special tools are recommended to perform procedures in this section. The use of these tools is shown in the appropriate procedure. These tools can be purchased from a local Cummins® Authorized Repair Location.

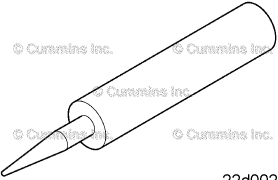
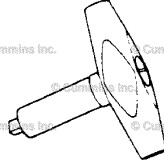
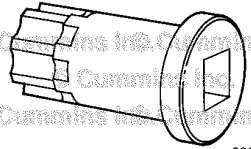
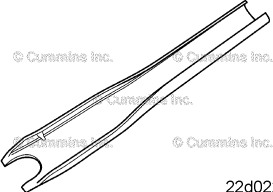
Tool No.	Tool Description	Tool Illustration
3822566	<p align="center">Blowby Tool — .302 Inch Orifice</p> <p>Used to measure the engine crankcase blowby. Use with manometer, Part Number ST 1111-3.</p>	 <p align="right">eg8toge</p>
ST 1111-3	<p align="center">Manometer</p> <p>Used to measure the engine crankcase blowby. Use with Blowby Orifice, Part Number 3822566.</p>	 <p align="right">eg100ja</p>
3164070	<p align="center">RTV Sealant</p> <p>Used to seal crankcase breather cover plate.</p>	 <p align="right">22d00220</p>
3823208	<p align="center">Torque Wrench - Inch-Pound</p> <p>Used to tighten injector terminal nuts.</p>	 <p align="right">3823208</p>
3824591	<p align="center">Barring Tool</p> <p>Used to engage the flywheel ring gear to rotate the crankshaft.</p>	 <p align="right">3824591</p>
3165175	<p align="center">Barring Plug Remover</p> <p>Quickly removes stubborn barring plugs from flywheel housing.</p>	 <p align="right">22d0223</p>

Crankcase Breather (External) (003-001)

General Information

Due to the number of crankcase breather configurations, the following procedure has been generalized to cover the majority of the engine configurations. The illustrations provided may **not** match the part that is being removed/installed.

In general, the crankcase breather consists of four main components:

- 1 A rocker lever cover mounted breather/baffle
- 2 A crankcase breather oil drain line
- 3 For rear gear train engines, a crankcase breather tube connection that connects the rocker lever cover to the rear gear housing
- 4 A crankcase breather tube. Refer to Procedure Procedure 003-018

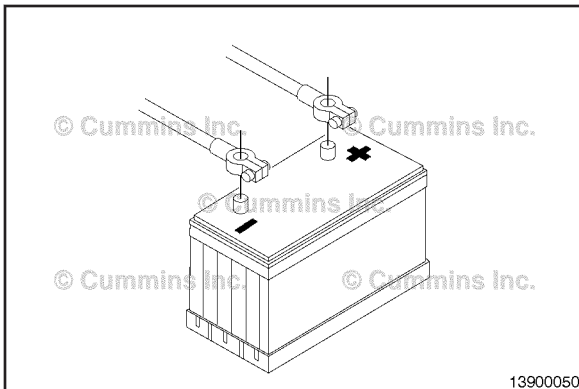

Preparatory Steps

⚠ WARNING ⚠

Batteries can emit explosive gases. To reduce the possibility of personal injury, always ventilate the compartment before servicing the batteries. To reduce the possibility of arcing, remove the negative (-) battery cable first and attach the negative (-) battery cable last.

Disconnect the batteries.

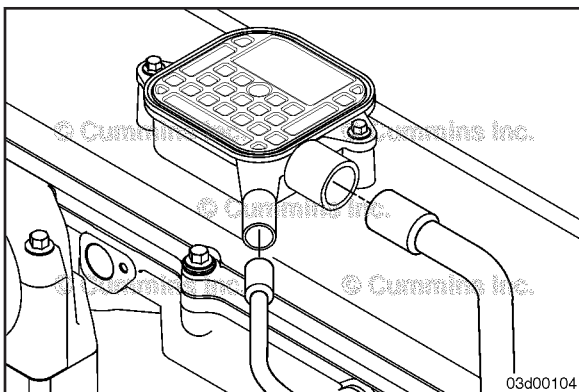

Remove

NOTE: It may be necessary to remove an engine cover to access the crankcase breather/rocker lever cover. Refer to the OEM instructions.

Disconnect the crankcase breather tube from the crankcase breather assembly.

Disconnect the crankcase breather oil drain line from the crankcase breather assembly.

Remove the two mounting capscrews.

Remove the breather from the rocker lever cover by pulling straight up on the breather assembly.

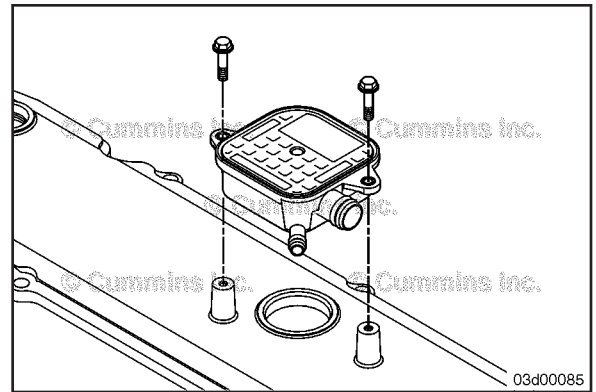

If equipped, remove and note the locations of any p-clips securing the breather oil drain line.

Disconnect the breather oil drain line from the drain fitting on the cylinder block mounted cover plate.

Remove the breather oil drain line.

Remove the capscrews, cover plate, and gasket from the cylinder block.

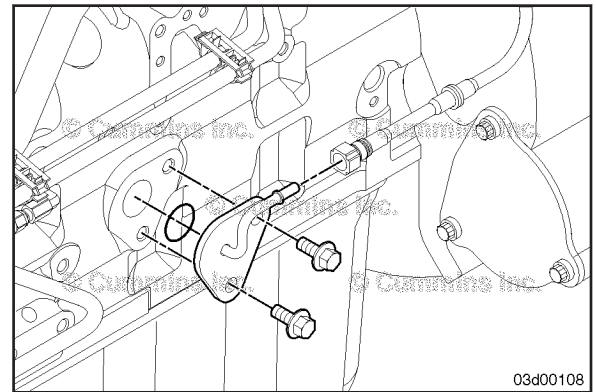

Clean and Inspect for Reuse



WARNING
Wear appropriate eye and face protection when using compressed air. Flying debris and dirt can cause personal injury.

Use hot soapy water and a soft brush to clean the crankcase breather.

Dry with compressed air.

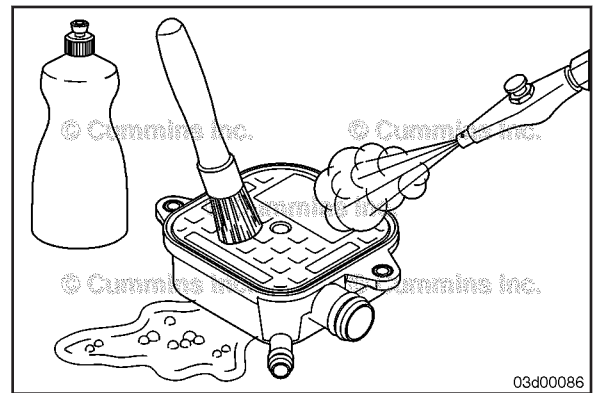

Inspect the breather for cracks or other damage. Replace if any damage is found.

Make sure to inspect the O-ring for cracks, tears, or brittleness.

Replace if any damage is found.

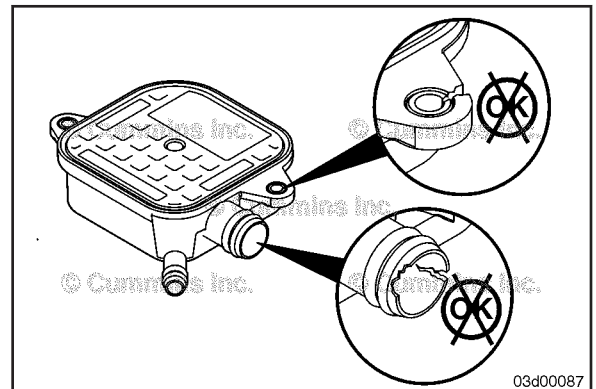

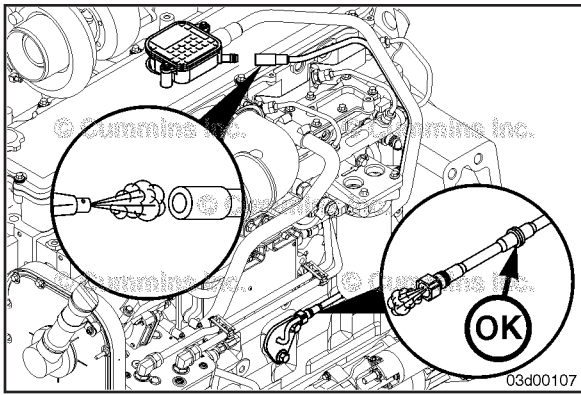

Inspect the breather drain line check valve for correct operation.

The check valve should:

- 1 Allow oil to drain from the breather to the oil pan
- 2 Should prevent crankcase gases from traveling up to the breather.

A small amount of air can be blown through the line (less than 34 kPa [5 psi]) to check the check valve operation.

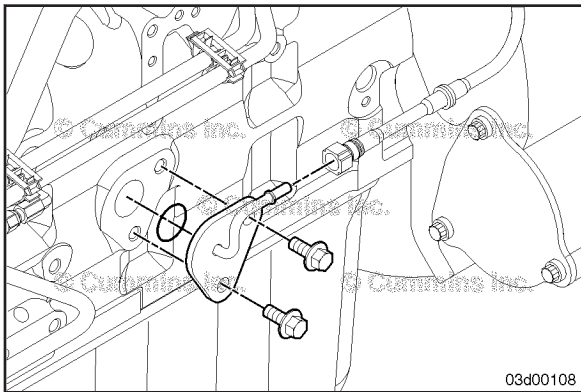

Install

Install the capscrews, cover plate and new gasket to the cylinder block.



Torque Value: 24 N•m [18 ft-lb]

Connect the breather oil drain line to the drain fitting on the cylinder block mounted cover plate.

Route the breather oil drain line to the crankcase breather mounting location.

If equipped, install any p-clips removed that secure the breather oil drain line.

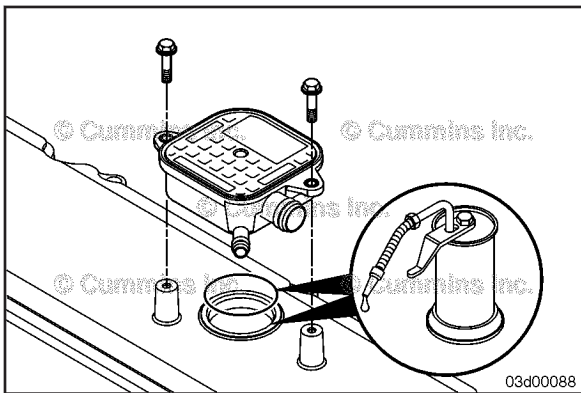

Install the breather and mounting capscrews into the rocker lever cover.



Lubricate the o-ring and the rocker lever valve cover with lubricating oil.

Tighten the capscrews.



Torque Value: 10 N•m [89 in-lb]

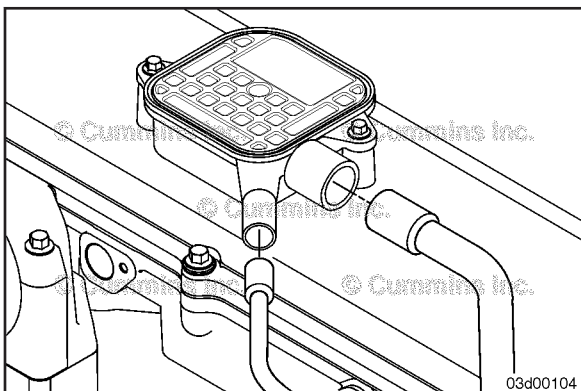

Connect the crankcase breather tube to the crankcase breather assembly.

Connect the crankcase breather oil drain line to the crankcase breather assembly.

NOTE: It may be necessary to install an engine cover previously removed. Refer to the OEM instructions.

Finishing Steps

⚠ WARNING ⚠

Batteries can emit explosive gases. To reduce the possibility of personal injury, always ventilate the compartment before servicing the batteries. To reduce the possibility of arcing, remove the negative (-) battery cable first and attach the negative (-) battery cable last.

Connect the batteries.

Operate engine and check for leaks.

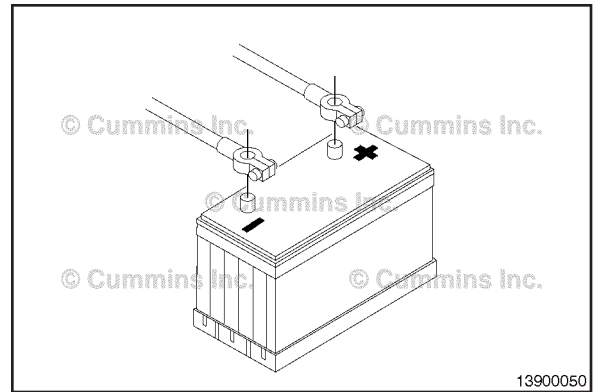

Crankcase Breather (Internal) (003-002)

General Information

Due to the number of crankcase breather configurations, the following procedure has been generalized to cover the majority of the engine configurations. The illustrations provided may **not** match the part that is being removed/installed.

In general, the crankcase breather consists of four main components:

- 1 A rocker lever cover mounted breather/baffle.
- 2 A crankcase breather oil drain line.
- 3 For rear gear train engines, a crankcase breather tube connection that connects the rocker lever cover to the rear gear housing.
- 4 A crankcase breather tube. Refer to Procedure Procedure 003-018

Preparatory Steps

⚠ WARNING ⚠

Batteries can emit explosive gases. To reduce the possibility of personal injury, always ventilate the compartment before servicing the batteries. To reduce the possibility of arcing, remove the negative (-) battery cable first and attach the negative (-) battery cable last.

Disconnect the batteries.

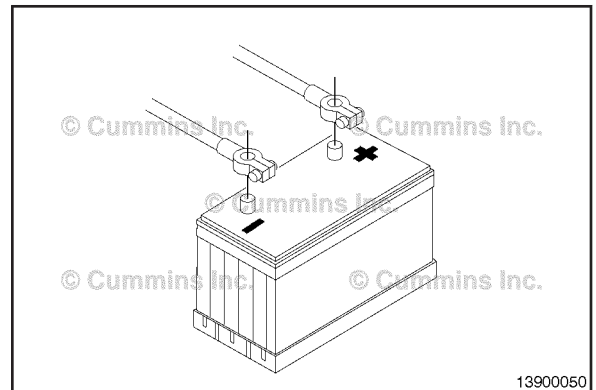

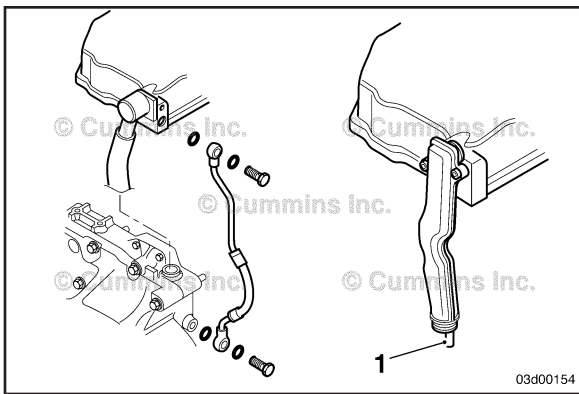

Remove

If equipped, remove the breather oil drain line which is located at the rear of the engine on the exhaust side of the engine.

Remove the breather oil drain line connections:

- 1 Remove the oil drain line banjo bolt and sealing washers from the rear of the rocker lever cover
- 2 Remove the oil drain line banjo bolt and sealing washers from the rear gear housing
- 3 Remove the breather oil drain line.

NOTE: Not all engines with an internal mounted crankcase breather are equipped with an external breather oil drain line. On some engines the breather oil drain line is internal to the breather connection tube (1).

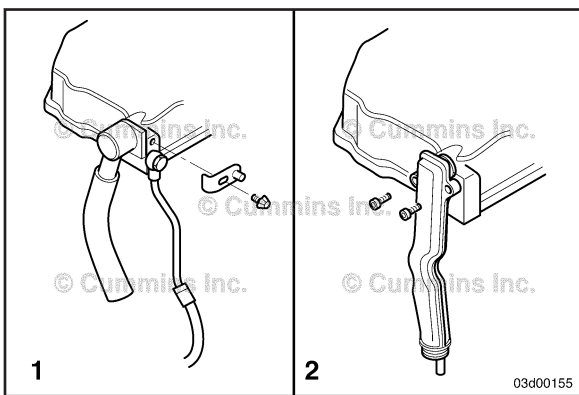

Disconnect the breather tube connection at the back of the rocker lever cover.

In general, two type of breather tube connections are used at the rocker lever cover:

- 1 A clamping plate and capscrew hold the breather tube connection to the rocker lever cover. Remove the capscrew and clamping plate to disconnect the breather tube connection from the rocker lever cover.
- 2 1 or 2 Capscrew(s) directly mount the breather tube connection to the rocker lever cover. Remove the capscrew(s) to disconnect the breather tube connection from the rocker lever cover.

NOTE: Some breather tube connections use internal torx capscrews to secure the breather tube connection to the rocker lever cover.

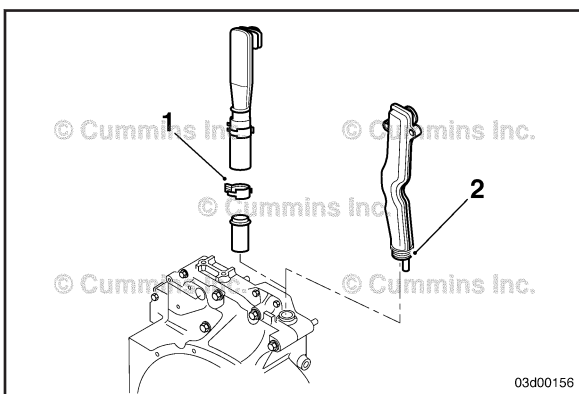

Remove the breather tube connection from the rear gear housing.

In general, two type of breather tube connections are used at the rear gear housing:

- 1 An o-ring sealed connection. Remove the breather tube connection by pulling straight up
- 2 A clamped hose. Remove/loosen the clamp and pull straight up on the hose to remove the breather tube connection.

Remove the rocker lever cover to gain access to the internal breather baffle mounted inside the rocker lever cover. Refer to Procedure Procedure 003-011

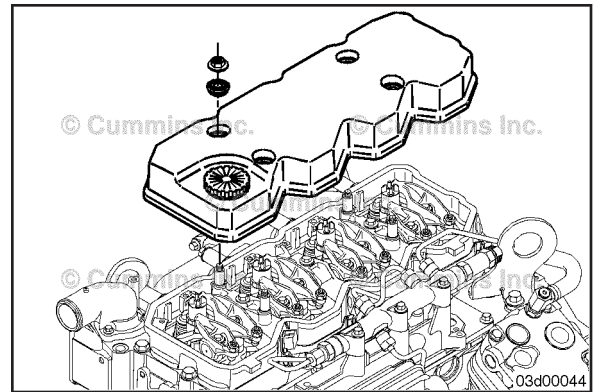

Remove the breather oil drain back tube banjo bolt from the rear of the rocker lever cover.

Loosen and remove the closed crankcase breather system hose.

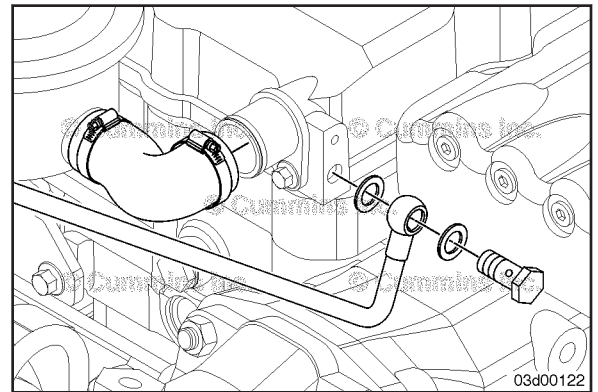

Remove the p-clamp on the oil drain back tube from the side of the engine block.

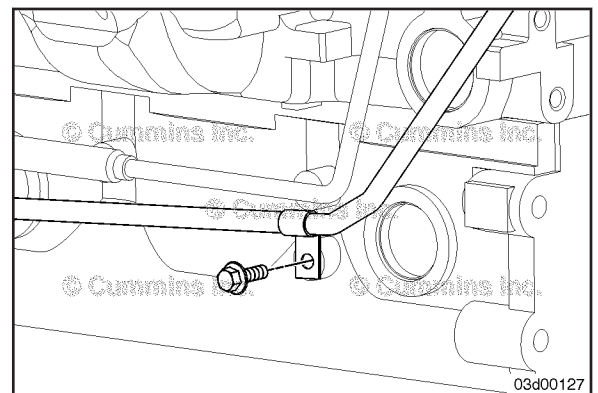

Disconnect the breather oil drain back tube fitting from the check valve on the side of the engine block.

Remove the breather oil drain back tube.

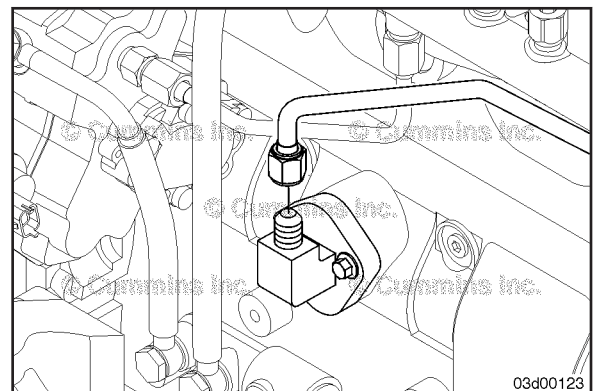

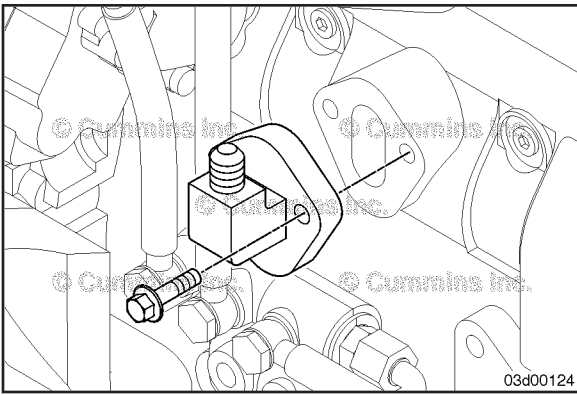

Remove the check valve from the side of the engine by removing the two capscrews and the connection block.

Remove the rocker lever cover. Refer to Procedure 003-011

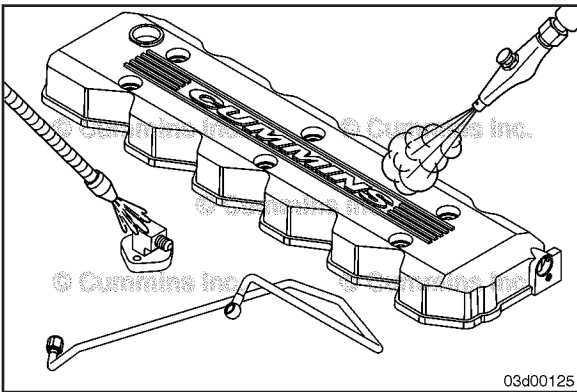

Clean and Inspect for Reuse

⚠ WARNING ⚠

When using solvents, acids, or alkaline materials for cleaning, follow the manufacturer's recommendations for use. Wear goggles and protective clothing to reduce the possibility of personal injury.

⚠ WARNING ⚠

Wear appropriate eye and face protection when using compressed air. Flying debris and dirt can cause personal injury.

Use a solvent to clean the removed components.

Dry with compressed air.

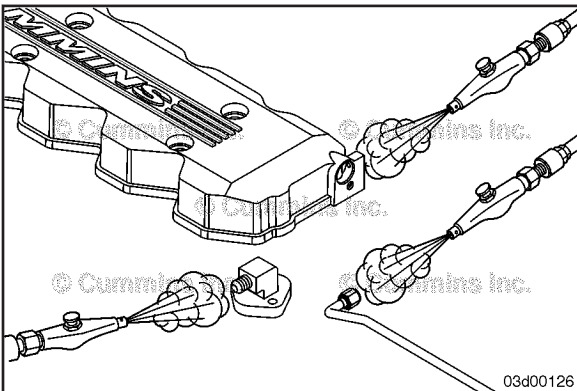

⚠ WARNING ⚠

Wear appropriate eye and face protection when using compressed air. Flying debris and dirt can cause personal injury.

Use compressed air to blow through the crankcase breather cavity in the rocker lever cover and breather oil drain line.

A small amount of air can be blown through the check valve (less than 34 kPa [5 psi]) to check the check valve operation.

If the breather cavity or check valve is clogged and the restriction can **not** be removed by cleaning, the cover or check valve **must** be replaced.

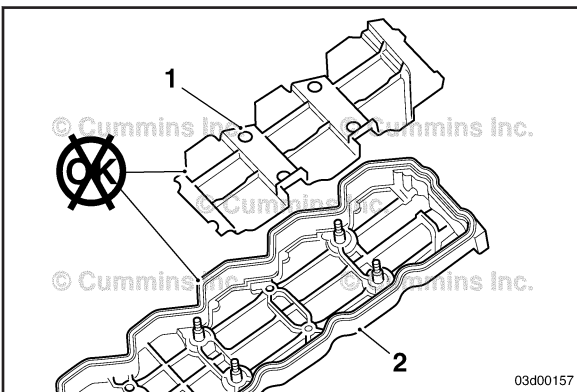

⚠ CAUTION ⚠

On engines equipped with an internal breather baffle(1), do not remove the baffle. Removal of the internal breather baffle mounting fasteners may damage the rocker lever cover (2).

It is **not** necessary to remove the baffle. There is no mesh or screening located internal to the breather baffle.

On components equipped with an o'ring seal, make sure to inspect the o'ring for cracks, tears, or brittleness. If any damage is found, replace the o'ring.

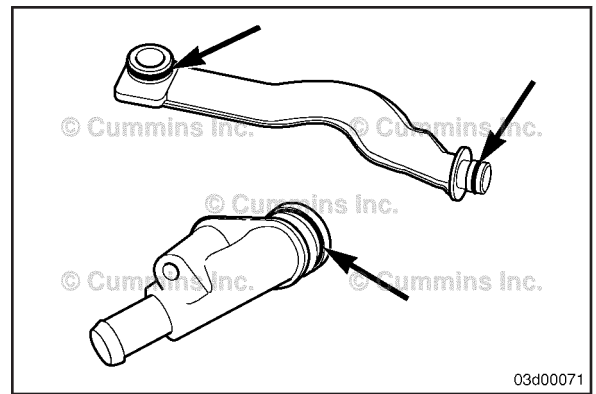

Install

Install the rocker lever cover. Refer to Procedure 003-011

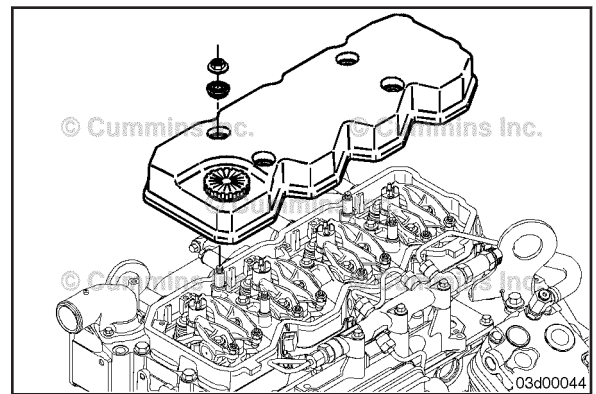

Prior to installing the breather connection tube, apply clean engine oil to the o'ring(s) located on the breather tube connection.

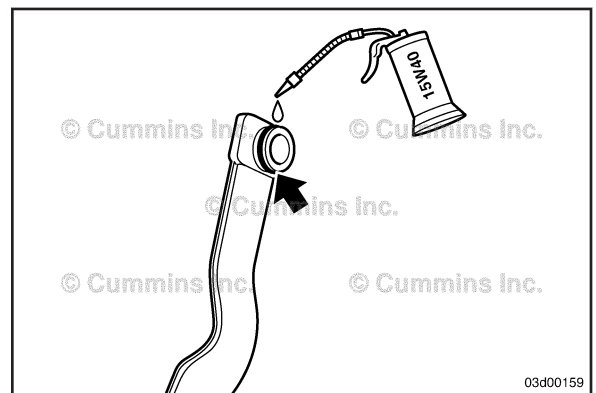

Install the breather tube connection into the rear gear housing.



In general, two type of breather tube connections are used at the rear gear housing:

- 1 An o'ring sealed connection. Install the breather tube connection by inserting the breather tube connection into the rear gear housing until fully seated
- 2 A clamped hose. Install the breather tube connection hose onto the inlet at the rear gear housing and install/tighten the clamp.

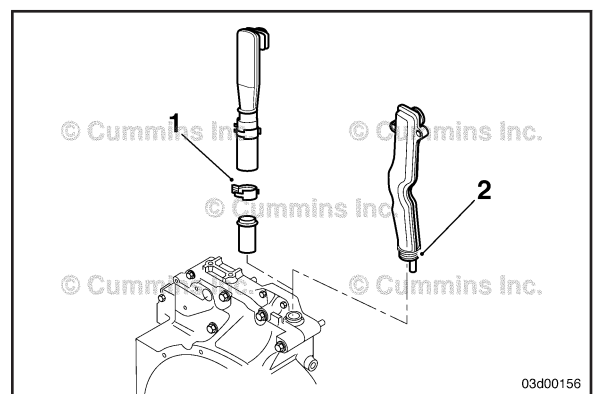

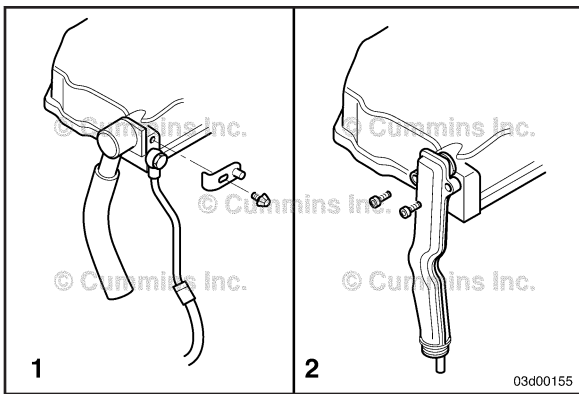

Connect the breather tube connection to the rocker lever cover.

In general, two types of breather tube connections are used at the rocker lever cover:

- 1 A clamping plate and capscrew hold the breather tube connection to the rocker lever cover. Install the capscrew and clamping plate to connect the breather tube connection to the rocker lever cover.
- 2 1 or 2 Capscrew(s) directly mount the breather tube connection to the rocker lever cover. Install the capscrew(s) to connect the breather tube connection to the rocker lever cover.

Tighten the Capscrew(s).

Torque Value: 10 N•m [89 in-lb]

NOTE: Some breather tube connections use internal torx capscrews to secure the breather tube connection to the rocker lever cover.

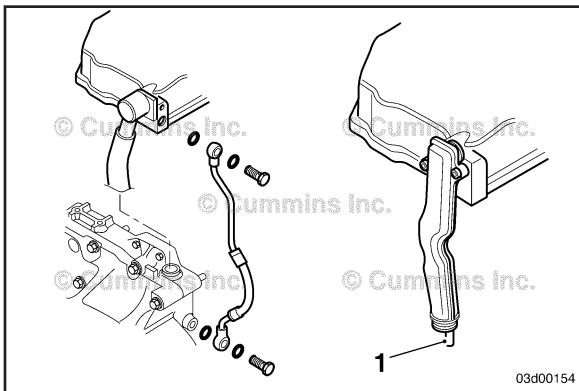

If equipped, install the breather oil drain line.

First, at the rear of the rocker lever cover, install the banjo bolt and sealing washers connecting the breather oil drain line to the rocker lever cover.

Torque Value: 12 N•m [106 in-lb]

Second, at the rear of the engine on the exhaust side, install the banjo bolt and sealing washers connecting the breather oil drain line to the rear gear housing.

Torque Value: 12 N•m [106 in-lb]

NOTE: Not all engines with an internal mounted crankcase breather are equipped with an external breather oil drain line. On some engines the breather oil drain line is internal to the breather connection tube (1).

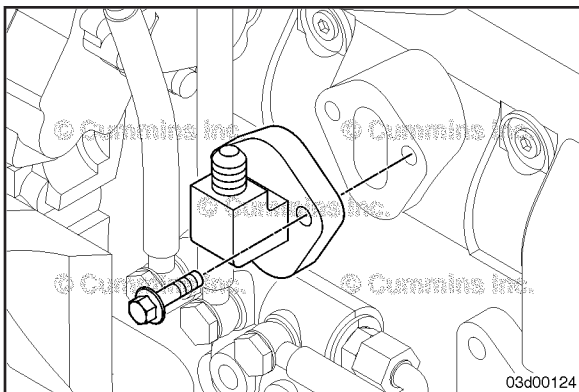

Install the rocker lever cover. Refer to Procedure 003-011

Install a new gasket and the check valve connection to the side of the engine block.



Tighten the capscrews.

Torque Value: 24 N•m [18 ft-lb]

Connect the breather oil drain back tube fitting to the check valve.

Torque Value: 30 N•m [26 ft-lb]

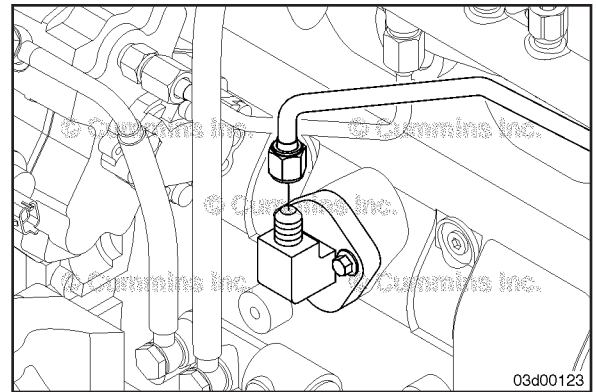

Connect the closed crankcase breather system hose to the rocker lever cover breather port.

Tighten the hose clamps.

Torque Value: 6 N•m [53 in-lb]

Install the banjo bolt and sealing washers connecting the breather oil drain line to the rocker lever cover.

Torque Value: 12 N•m [106 in-lb]

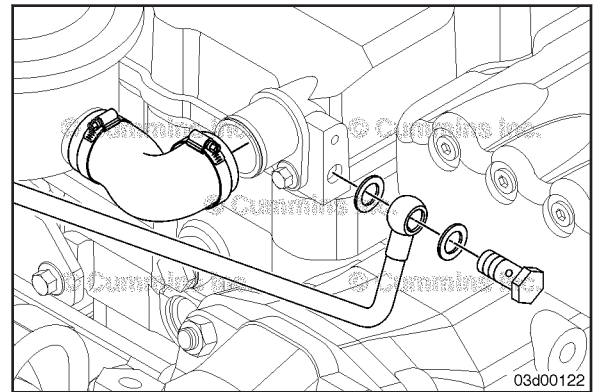

Install the p-clamp around the breather oil drain back tube to the side of the engine block.

Torque Value: 24 N•m [18 ft-lb]

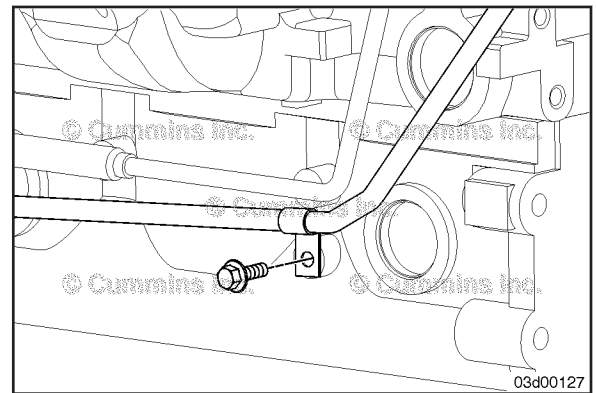

Finishing Steps

⚠ WARNING ⚠

Batteries can emit explosive gases. To reduce the possibility of personal injury, always ventilate the compartment before servicing the batteries. To reduce the possibility of arcing, remove the negative (-) battery cable first and attach the negative (-) battery cable last.

Connect the batteries.

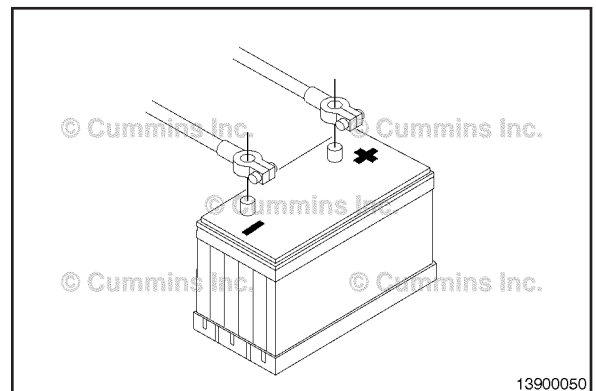

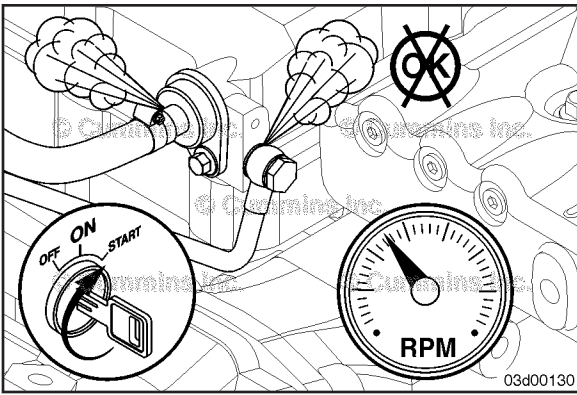

Operate the engine and check for leaks.

Overhead Set (003-004)

General Information

Overhead setting is **only** required at the interval specified in the appropriate Operation and Maintenance Manual/ Owners Manual or when engine repairs cause removal of the rocker levers and/or loosening of the adjusting screws.

Excessive valve lash prior to this can indicate an overhead set incorrectly from a previous repair, worn valve stems, crossheads, push rods, or rocker levers*.

Loose rocker levers and the need to reset the valve clearance frequently can also indicate camshaft lobe or tappet wear. If an inspection of the rocker levers, valve stems, crossheads, and push rod does **not** show wear, then tappet and/or camshaft lobe wear can be suspected.

Refer to Procedure 001-008 in Section 1. Refer to Procedure 004-015 in Section 4.

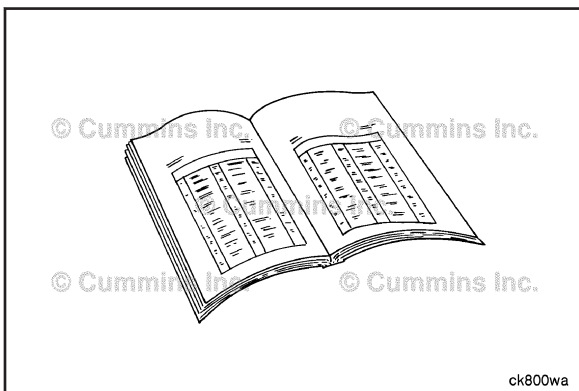

Preparatory Steps

⚠ WARNING ⚠

Batteries can emit explosive gases. To reduce the possibility of personal injury, always ventilate the compartment before servicing the batteries. To reduce the possibility of arcing, remove the negative (-) battery cable first and attach the negative (-) battery cable last.

- Disconnect the batteries. Refer to Procedure 013-009 in Section 13.
- Remove the rocker lever cover and gasket. Refer to Procedure 003-011 in Section 3.

Adjust

NOTE: Engine coolant temperature **must** be less than 60°C [140°F].

NOTE: For marine engines equipped with a TDC mark on the vibration damper, use the Adjust step for All Applications Except Marine.

NOTE: For marine engines **not** equipped with a TDC mark on the vibration damper, use the Adjust step for Marine Applications.

Use the barring tool, Part Number 3824591 to rotate the crankshaft until the number 1 cylinder is at TDC.

TDC can be determined by the following methods:

For 3.9 L and 5.9 L Engines without EGR, align the crankshaft speed indicator ring on the front of the crankshaft so that the unpunched area of the crankshaft speed indicator ring is at the 12-o'clock position. If both number 1 cylinder rocker levers are loose, move to the following steps. If both number 1 cylinder rocker levers are **not** loose, rotate the crankshaft 360 degrees.

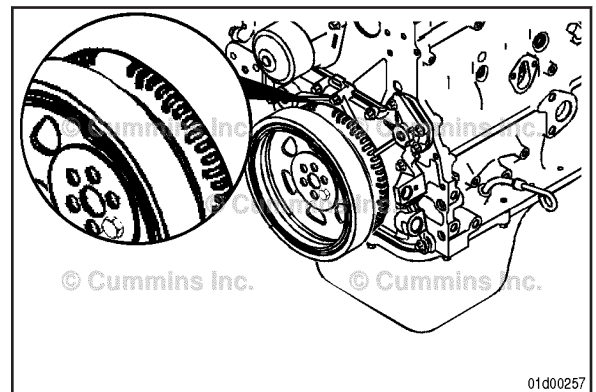
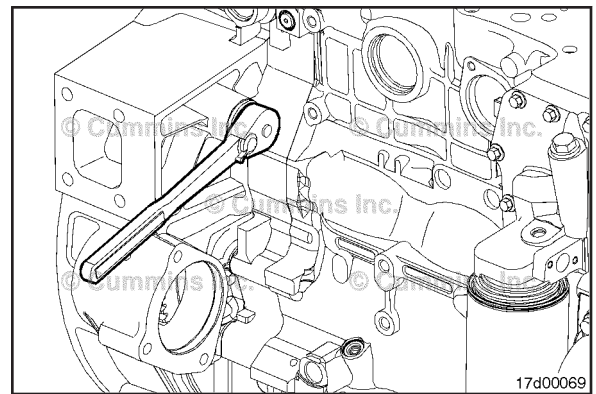

NOTE: The TDC indicator is on the vibration damper/crankshaft speed indicator ring.

For all 4.5 L, 5.9 L engines with EGR, and 6.7 L engines, align the vibration damper/crankshaft speed indicator ring so that the TDC indicator is at the 12-o'clock position. If both number 1 cylinder rocker levers are loose, move to the following steps. If both number 1 cylinder rocker levers are **not** loose, rotate the crankshaft 360 degrees.

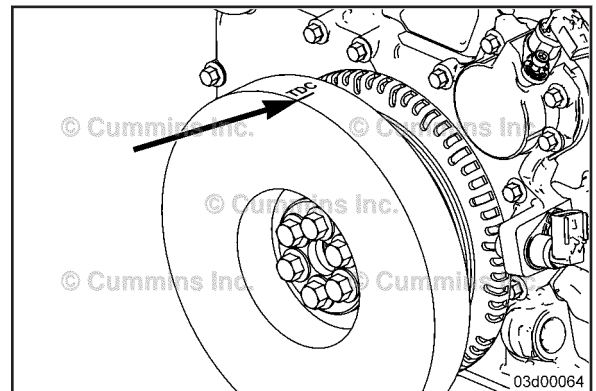

NOTE: If no TDC mark is present on either the vibration damper or the crankshaft speed indicator ring, align the large gap in the crankshaft speed indicator ring to the 5-o'clock position (2). The dowel pin could also be visible in the 9-o'clock position (1). Check that both number 1 cylinder rocker levers are loose. If they are **not** loose, rotate the crankshaft 360 degrees and recheck.

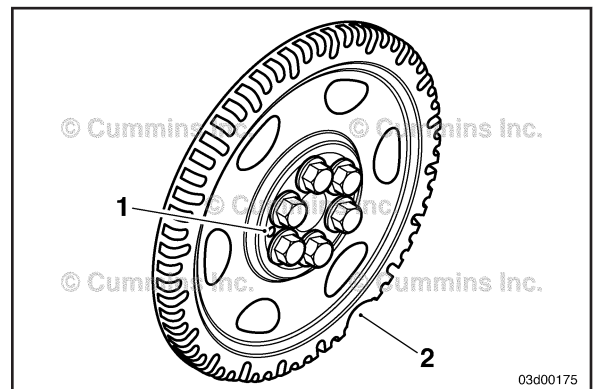

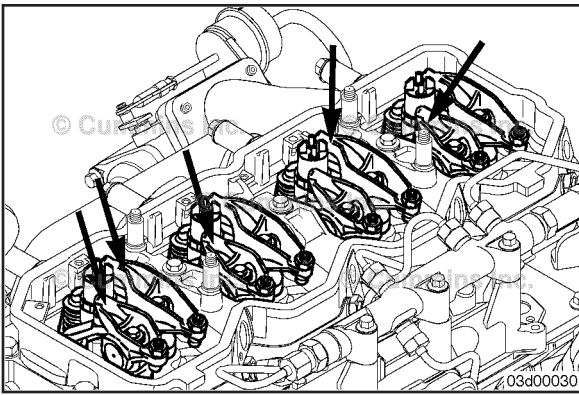

With the engine in this position, lash can be measured on the following rocker levers:

(E = exhaust, I = Intake)

Four-cylinder 1I, 1E, 2I, and 3E:

Six-cylinder 1I, 1E, 2I, 3E, 4I, and 5E.

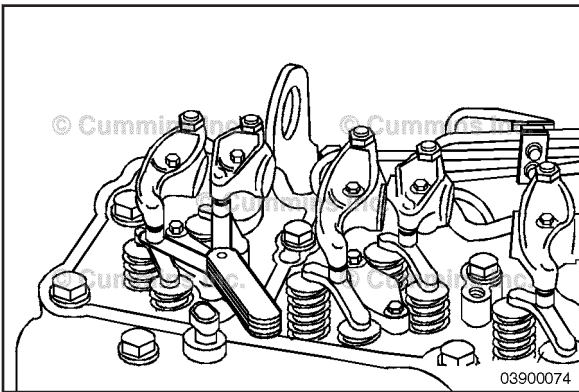

Lash Check Limits

	mm		in
Intake	0.152	MIN	0.006
	0.381	MAX	0.015
Exhaust	0.381	MIN	0.015
	0.762	MAX	0.030

NOTE: Checking the overhead setting is usually performed as part of a troubleshooting procedure, and resetting is **not** required during checks as long as the lash measurements are within the above ranges.

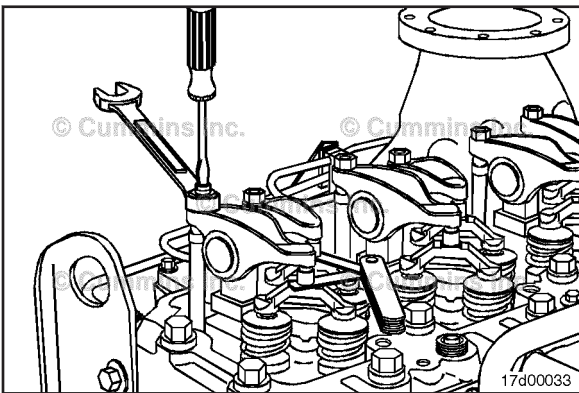

NOTE: The clearance is correct when some resistance is "felt" when the feeler gauge is slipped between the crosshead and the rocker lever socket.



Measure lash by inserting a feeler gauge between the crosshead and the rocker lever socket. If the lash measurement is out of specification, loosen the locknut, and adjust the lash to nominal specifications.

Valve Lash Specifications (Nominal)		
	mm	in
Intake	0.254	0.010
Exhaust	0.508	0.020

Tighten the locknut and measure the lash again.

Torque Value: 24 N•m [212 in-lb]

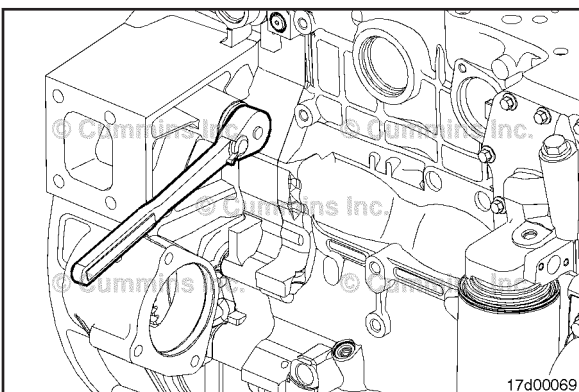

Using barring tool, Part Number 3824591, rotate the crankshaft 360 degrees.



Following the same steps and specifications as previously stated, measure lash for the following rocker levers:

(E = exhaust, I = Intake)

Four-cylinder 2E, 3I, 4E, and 4I:

Six-cylinder 2E, 3I, 4E, 5I, 6I, and 6E.

Reset if out of specification.

NOTE: The engine coolant temperature **must** be less than 60°C [140°F].

NOTE: For marine engines equipped with a TDC mark on the vibration damper, use the Adjust step for All Applications Except Marine.

NOTE: For marine engines **not** equipped with a TDC mark on the vibration damper, use the Adjust step for Marine Applications.

Use barring tool, Part Number 3824591, to rotate the crankshaft until the number 1 cylinder is at top-dead-center (TDC).

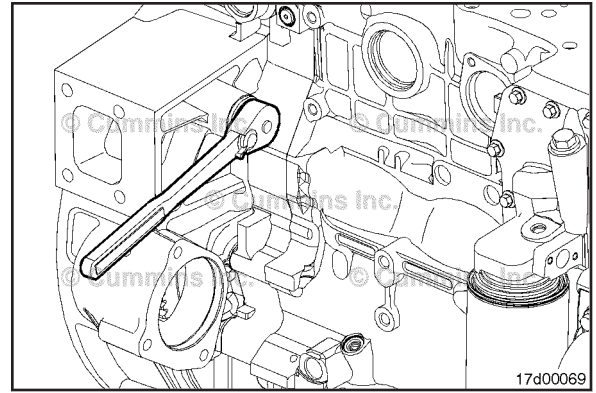

To determine TDC when setting the overhead on marine engines, rotate the crankshaft until either cylinder Number 1 or cylinder Number 6 exhaust and intake rocker levers are both loose.

NOTE: If a more precise way is needed to determine TDC, remove the injector from cylinder Number 1. Use a rod with a dial indicator to find TDC.

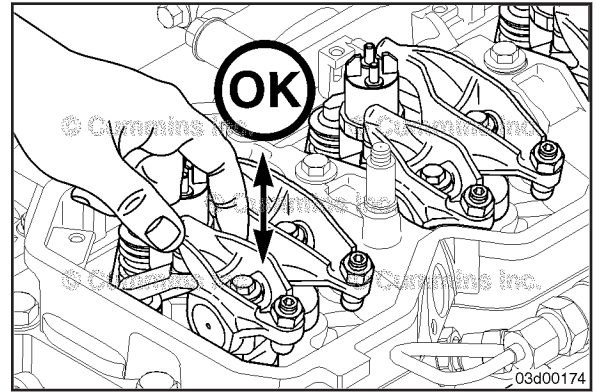

With the engine in this position, lash can be adjusted on the following rocker levers:

- (E = exhaust, I = intake)
- Four-cylinder - 1I, 1E, 2I, and 3E
- Six-cylinder - 1I, 1E, 2I, 3E, 4I, and 5E.

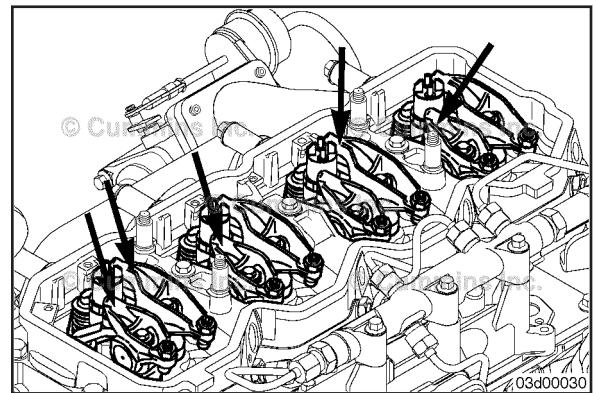

NOTE: The clearance is correct when some resistance is felt when the feeler gauge is slipped between the crosshead and the rocker lever socket.

Loosen the locknut and adjust the lash to nominal specifications.



Valve Lash Specifications (Nominal)

	mm	in
Intake	0.254	0.010
Exhaust	0.508	0.020

Tighten the locknut and measure the lash again.

Torque Value: 24 N•m [212 in-lb]

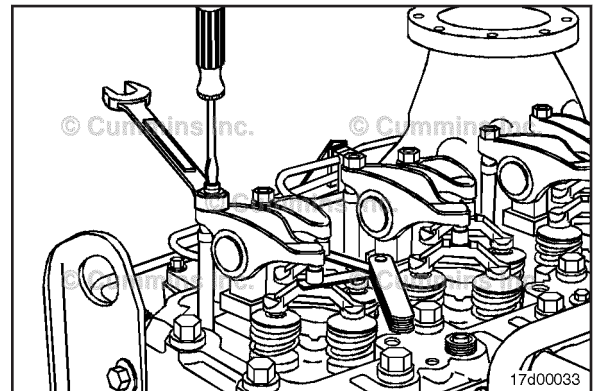

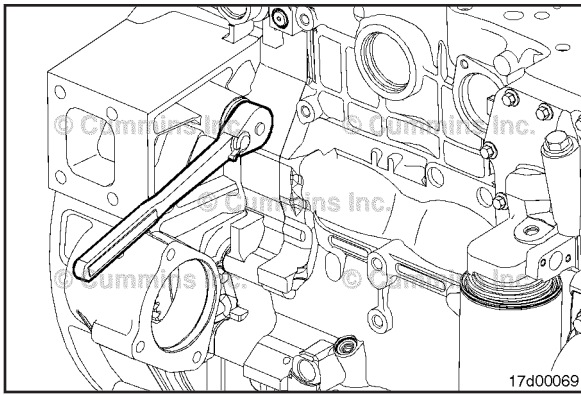

Use barring tool, Part Number 3824591, to rotate the crankshaft 360 degrees.



Follow the same steps and specifications as previously stated to continue adjusting the valve lash.

- (E = exhaust, I = intake)
- Four-cylinder - 2E, 3I, 4E, and 4I
- Six-cylinder - 2E, 3I, 4E, 5I, 6I, and 6E.

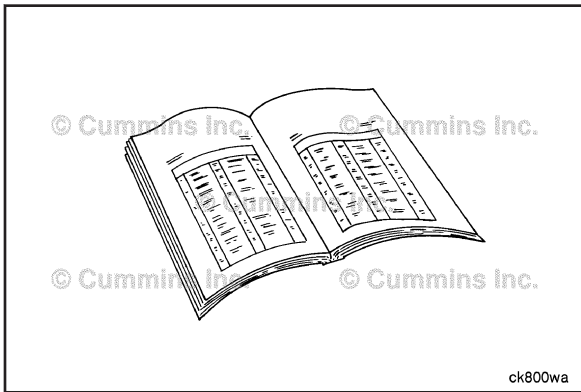

Finishing Steps

⚠ WARNING ⚠



Batteries can emit explosive gases. To reduce the possibility of personal injury, always ventilate the compartment before servicing the batteries. To reduce the possibility of arcing, remove the negative (-) battery cable first and attach the negative (-) battery cable last.

- Install the gasket and rocker lever cover. Refer to Procedure 003-011 in Section 3.
- Connect the batteries. Refer to Procedure 013-009 in Section 13.
- Operate the engine and check for leaks.

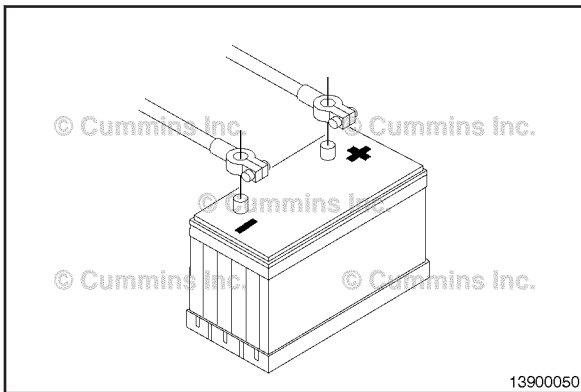

Rocker Lever (003-008)

Preparatory Steps

⚠ WARNING ⚠



Batteries can emit explosive gases. To reduce the possibility of personal injury, always ventilate the compartment before servicing the batteries. To reduce the possibility of arcing, remove the negative (-) battery cable first and attach the negative (-) battery cable last.

Disconnect the batteries.

Remove the rocker lever cover and gasket. Refer to Procedure 003-011

Remove

Loosen the adjusting screw locknuts.

Loosen the adjusting screws until they stop.

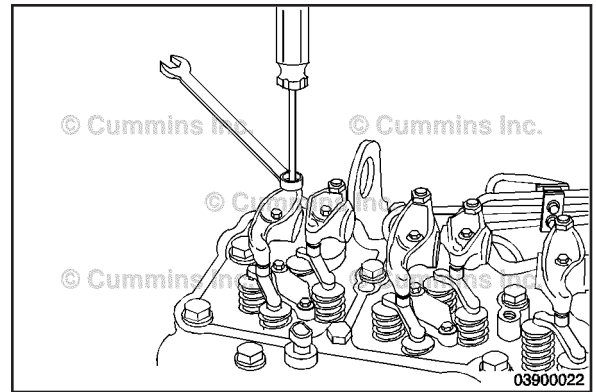

Remove the capscrews from the rocker lever pedestals.

Remove and mark the pedestals and rocker lever assemblies one at a time as to their location and position.

Remove and mark the crossheads one at a time as to their location and position. The crossheads and rocker assembly **must** be installed in their original location and position when reused.

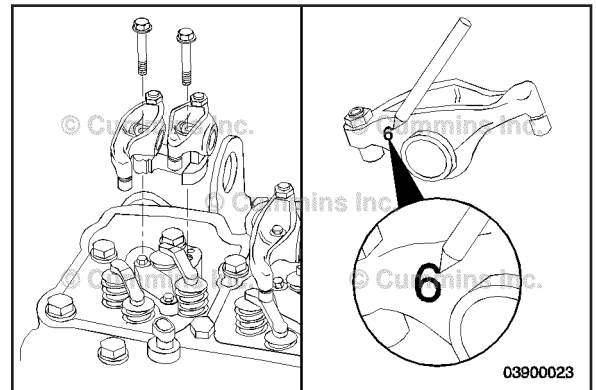

Mark the push rods to identify their location.

NOTE: The push rods **must** be installed in their original location and position.

Remove the push rods. Refer to Procedure 004-014

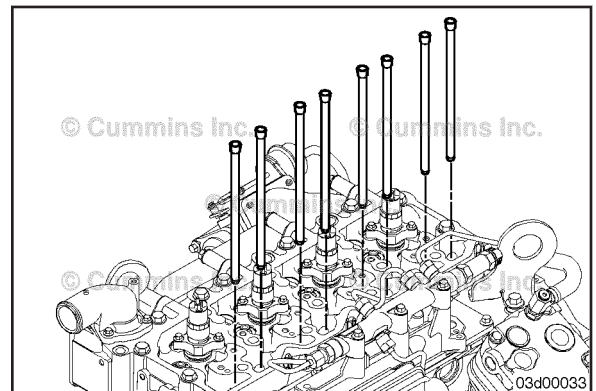

Disassemble

NOTE: All rocker lever components **must** be installed in their original location and position.

Remove the rocker levers from the pedestal.

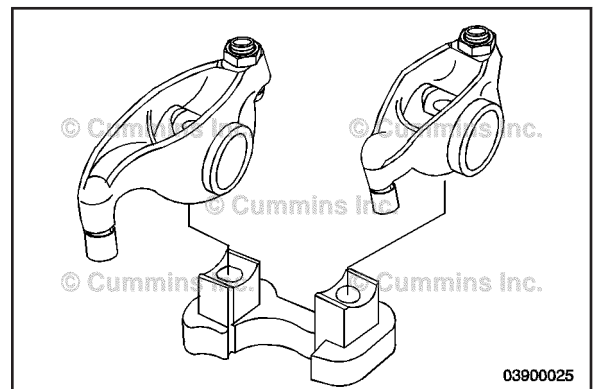

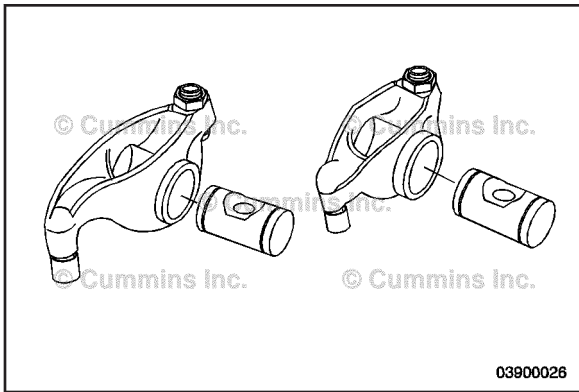

Remove the rocker lever shafts from the rocker levers.

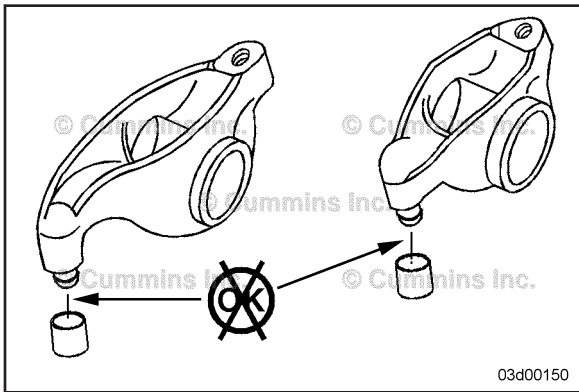

The socket at the tip of the rocker lever should **not** be removed.

This part is **not** serviceable.

If damage to the socket is found the rocker lever **must** be replaced.

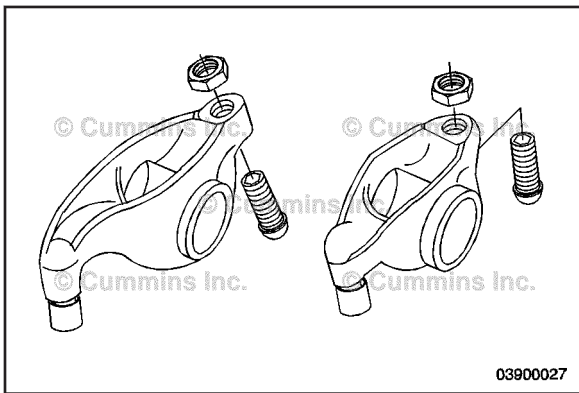

Remove the locknut and adjusting screw.

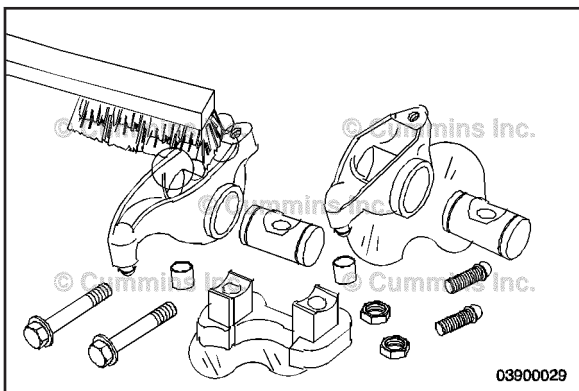

Clean and Inspect for Reuse

Clean all parts in a strong solution of laundry detergent and hot water.

⚠ WARNING ⚠

Wear appropriate eye and face protection when using compressed air. Flying debris and dirt can cause personal injury.

Use compressed air to dry the parts after rinsing in clean, hot water.

NOTE: The pedestals are made from powdered metal and will appear wet even after they have been cleaned and dried.

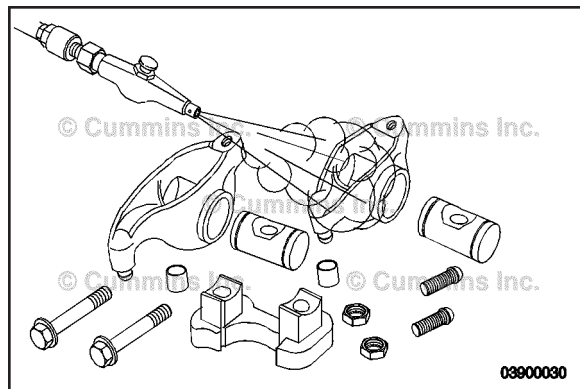

Inspect for cracks and excessive wear in the bore.

The socket should move freely on the rocker lever and the plastic socket retainer should be in place and not cracked.

Inspect for wear on the nose of the socket.

NOTE: The socket at the tip of the rocker lever should **not** be removed. This part is **not** serviceable. If damage to the socket is found the rocker lever **must** be replaced.

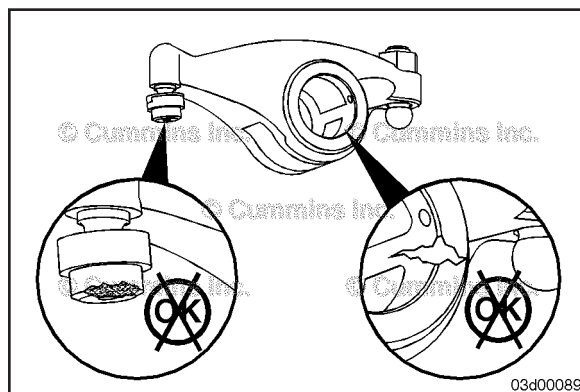

Measure the rocker lever bore.

Rocker Lever Bore

mm		in
22.027	MAX	0.867

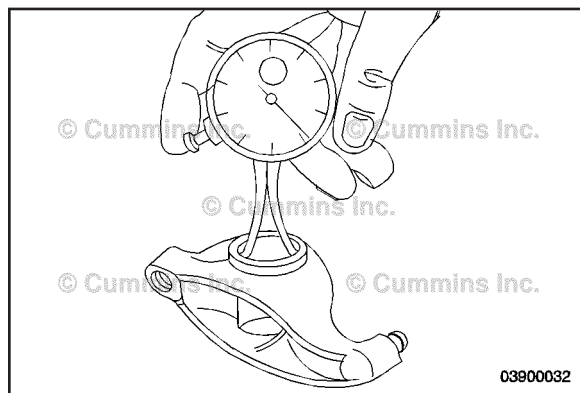

Inspect the rocker lever pedestal and rocker lever shaft.

It is **not** uncommon for the rocker lever shaft to have a polished appearance. Inspect for the following to determine rocker lever shaft reusability.

Measure the rocker lever shaft diameter.

Rocker Lever Shaft

mm		in
21.965	MIN	0.865

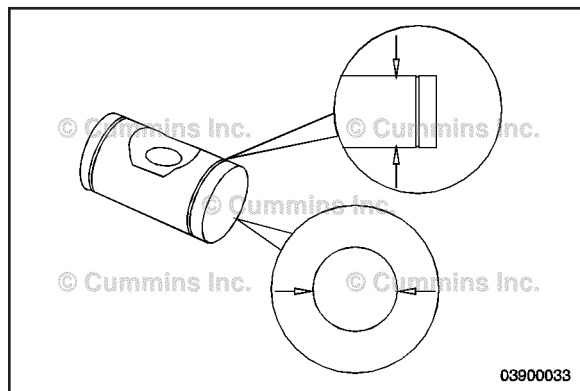

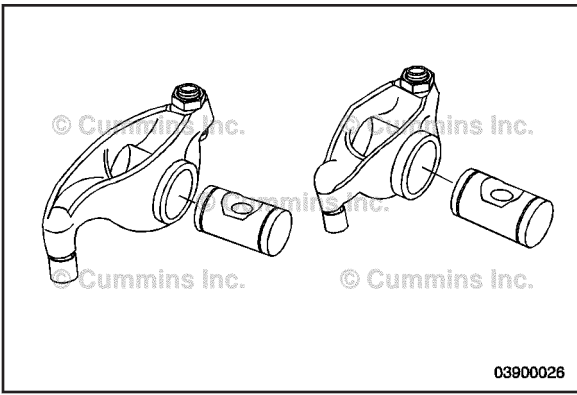

Lubricate the rocker lever shaft with clean 15W-40 engine lubricating oil.



Install the rocker lever shaft into the rocker lever and rotate the rocker lever 180 degrees about the rocker lever shaft. The rocker lever should rotate freely without any binding.

If the rocker lever does **not** rotate freely, replace the rocker lever shaft and rocker lever.

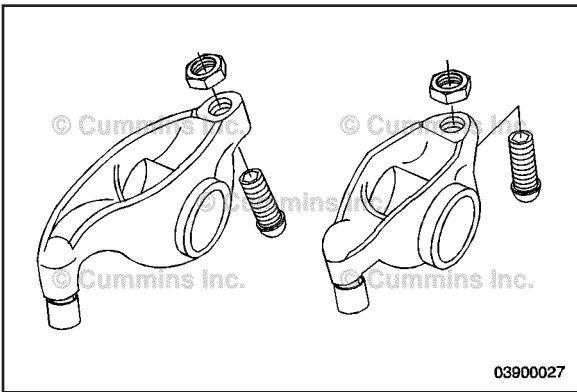

Assemble

NOTE: All rocker lever components **must** be installed in their original location and position.

Install the adjusting screw until it stops and then install the locknut.

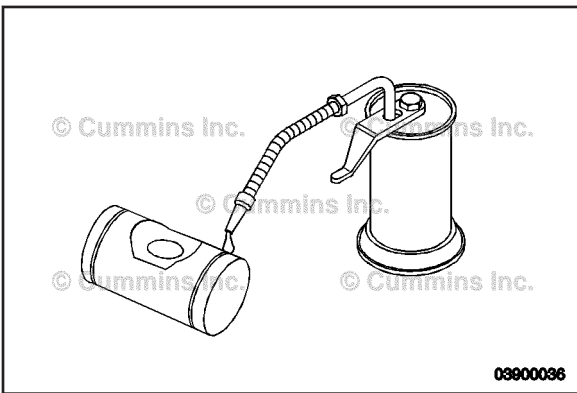

Lubricate the rocker lever shafts with clean 15W-40 engine lubricating oil.



Install the rocker lever shafts into the rocker levers.

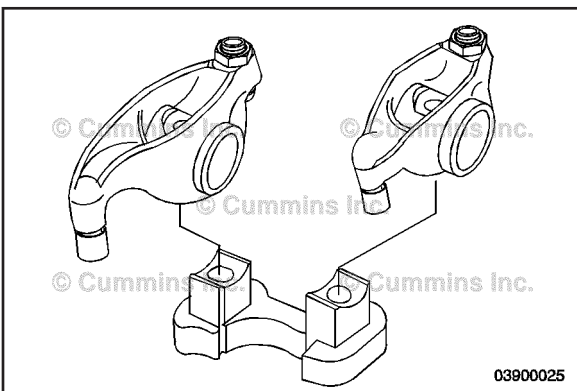

Position the rocker levers on the rocker pedestal.

⚠ CAUTION ⚠

Be sure to assemble the intake and exhaust rocker levers in the correct location. Failure to do so will result in engine damage.

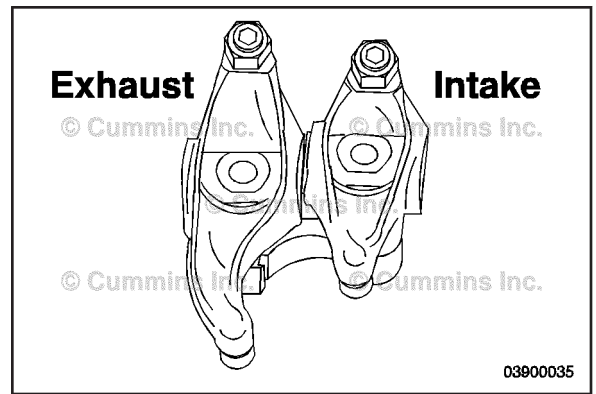

Install

Install the crossheads in their original location and position.

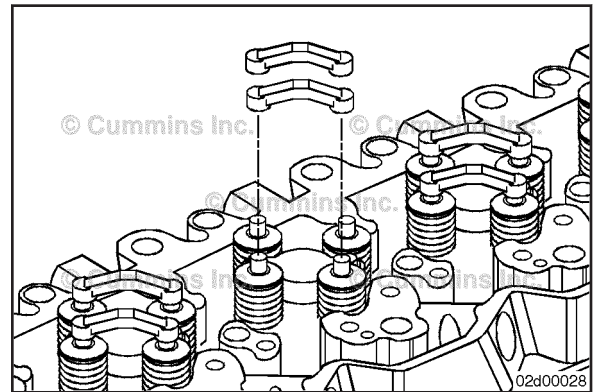

Install the push rods as marked during removal.
Install the push rods into the sockets of the valve tappets.
Lubricate the push rod sockets with clean 15W-40 lubricating engine oil.

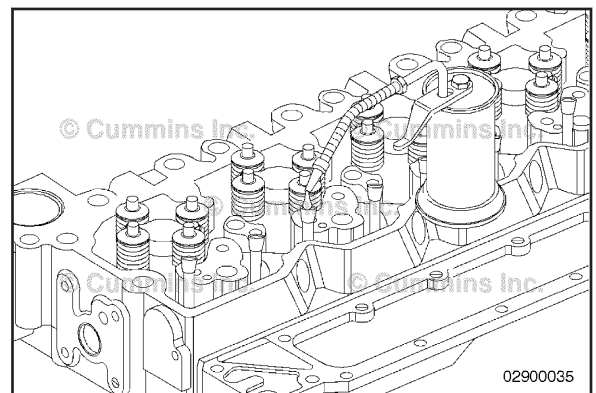

Install the rocker lever assemblies and pedestals in their original position.
Install the pedestal mounting capscrews.

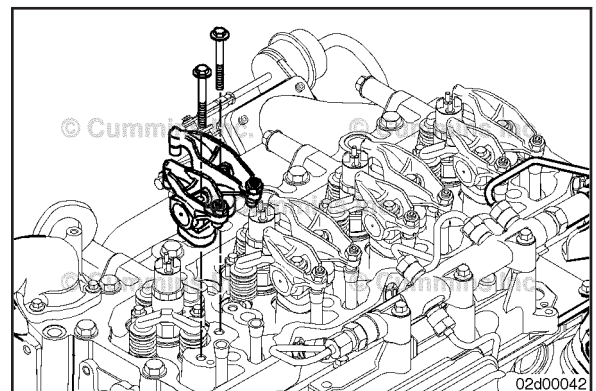

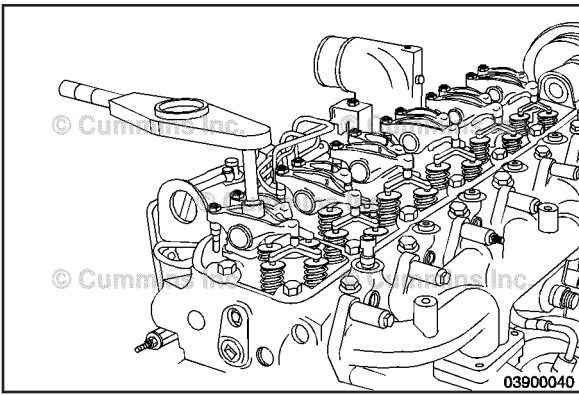

Tighten the pedestal mounting capscrews.

Torque Value: 36 N•m [27 ft-lb]

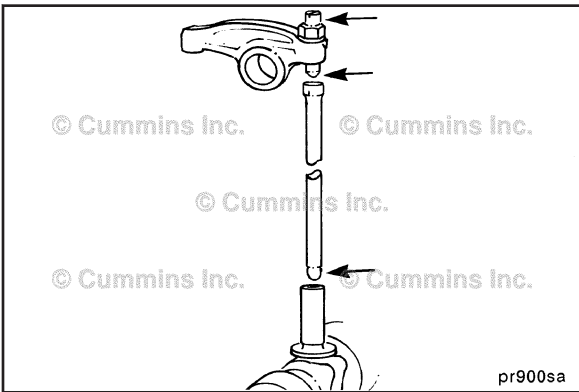

CAUTION

Rotate the adjusting screws until the adjusting screw contacts the socket of the push rod. This will ensure the push rod stays in contact with the tappet and adjusting screw when the engine is rotated to set valve lash. If not completed, the push rods may be bent or damaged.

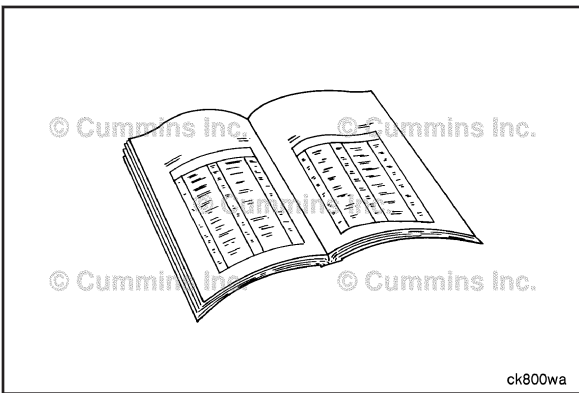

Finishing Steps

Set valve lash for intake and exhaust valves. Refer to Procedure 003-004

Install the rocker lever cover gasket and rocker lever cover. Refer to Procedure 003-011

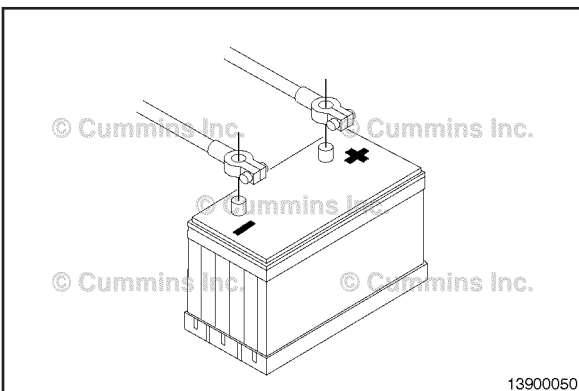

WARNING

Batteries can emit explosive gases. To reduce the possibility of personal injury, always ventilate the compartment before servicing the batteries. To reduce the possibility of arcing, remove the negative (-) battery cable first and attach the negative (-) battery cable last.

Connect the batteries.

Run the engine and check for leaks.

Rocker Lever Cover (003-011)

General Information

Due to the number of rocker lever configurations, the following procedure has been generalized to cover the majority of the engine configurations. The illustrations provided may **not** match the part that is being removed/installed.

Preparatory Steps

⚠ WARNING ⚠

Batteries can emit explosive gases. To reduce the possibility of personal injury, always ventilate the compartment before servicing the batteries. To reduce the possibility of arcing, remove the negative (-) battery cable first and attach the negative (-) battery cable last.

Disconnect the batteries. Refer to the OEM service manual.

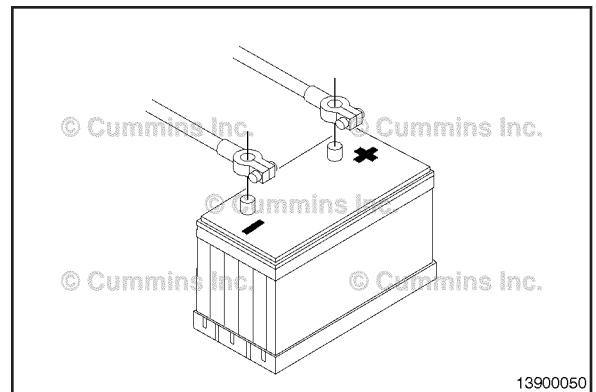

Remove

⚠ WARNING ⚠

Wear appropriate eye and face protection when using compressed air. Flying debris and dirt can cause personal injury.

Prior to removing any components, clean around the mounting fasteners and sealing joints with compressed air to remove any loose debris.

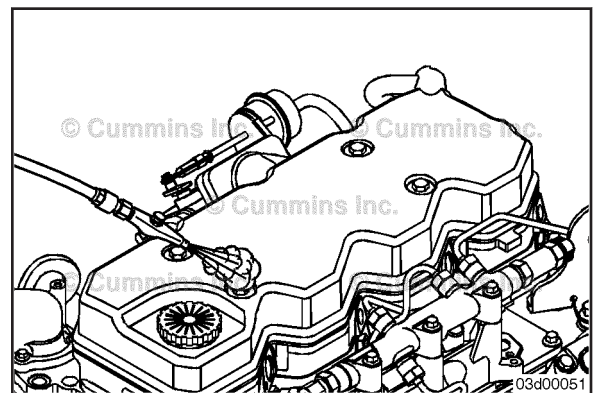

External Mounted Crankcase Breather.

NOTE: It may be necessary to remove an engine cover to access the crankcase breather/rocker lever cover. Refer to the OEM instructions.

Disconnect the crankcase breather tube from the crankcase breather assembly.

Disconnect the crankcase breather oil drain line from the crankcase breather assembly.

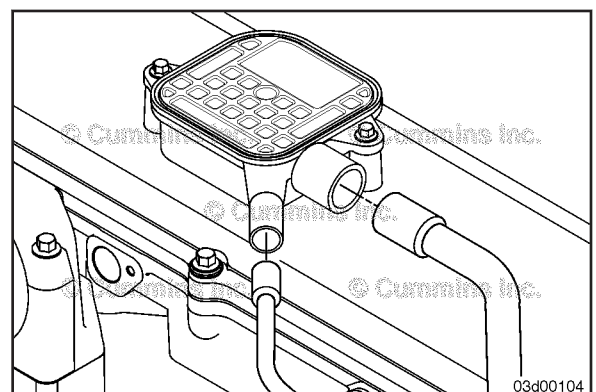

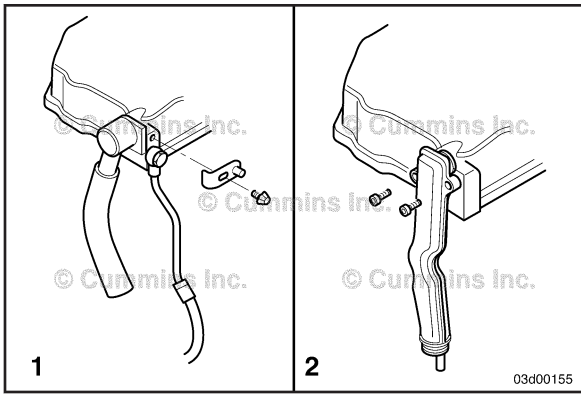

Internal Mounted Crankcase Breather

Disconnect the breather tube connection at the back of the rocker lever cover.

In general, two types of breather tube connections are used at the rocker lever cover:

- 1 A clamping plate and capscrew hold the breather tube connection to the rocker lever cover. Remove the capscrew and clamping plate to disconnect the breather tube connection from the rocker lever cover.
- 2 One or two capscrew(s) directly mount the breather tube connection to the rocker lever cover. Remove the capscrew(s) to disconnect the breather tube connection from the rocker lever cover.

NOTE: Some breather tube connections use internal torx capscrews to secure the breather tube connection to the rocker lever cover.

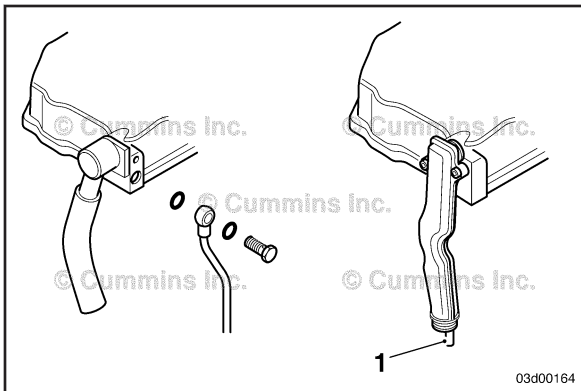

If equipped, at the rear of the rocker lever cover, remove the banjo bolt and sealing washers connecting the breather oil drain line to the rocker lever cover.

NOTE: Not all engines with an internal mounted crankcase breather are equipped with an external breather oil drain line. On some engines the breather oil drain line is internal to the breather connection tube (1).

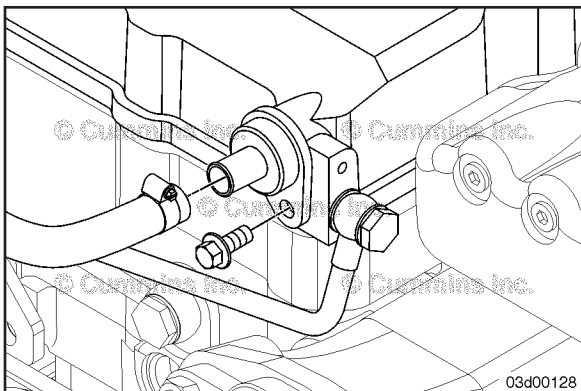

Marine Applications

Open Draft Tube Type

Remove the snap clamp and the crankcase breather tube.

Remove the capscrew and the cover plate.

Remove the banjo bolt and sealing washers connecting the breather oil drain line to the rocker lever cover.

Closed Draft Tube Type

Remove the breather oil drain back tube banjo bolt and sealing washer from the rear of the rocker lever cover.

Loosen and remove the closed crankcase breather system hose from the valve cover breather port.

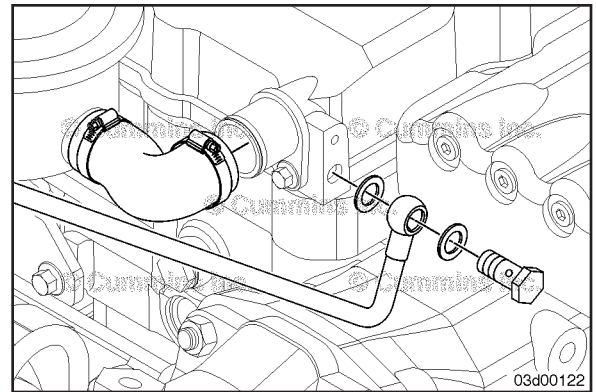

Stud Mounted Rocker Lever Cover.

NOTE: Do **not** remove the rocker lever cover gasket on engines in which the rocker lever cover gasket is fit into a groove at the base of the rocker lever cover. The gasket is reusable. Once the gasket is removed from the rocker lever cover, it **must** be replaced.

Remove the mounting nuts and isolators from the rocker lever cover.

NOTE: If equipped, it may be necessary to gently pry the breather tube connection from the back of the rocker lever cover while removing.

Remove the rocker lever cover.

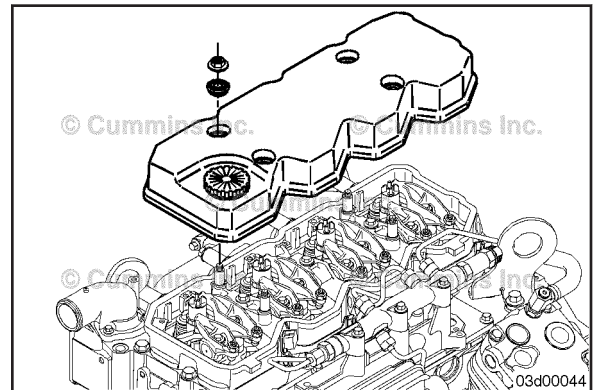

Capscrew Mounted Rocker Lever Cover

NOTE: Do **not** remove the rocker lever cover gasket on engines in which the rocker lever cover gasket is fit into a groove at the base of the rocker lever cover. The gasket is reusable. Once the gasket is removed from the rocker lever cover, it **must** be replaced.

Remove the mounting capscrews and isolators from the rocker lever cover.

NOTE: If equipped, it may be necessary to gently pry the breather tube connection from the back of the rocker lever cover while removing.

Remove the rocker lever cover.

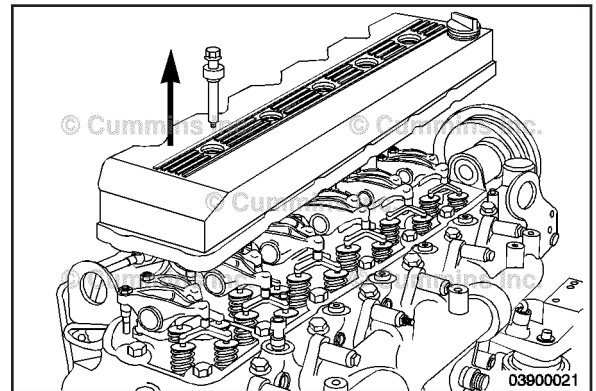

Disassemble

NOTE: The following disassemble steps are only required if replacing the rocker lever cover or disassembled component.

External Mounted Crankcase Breather.

Remove the two mounting capscrews.

Remove the breather from the rocker lever cover by pulling straight up on the breather assembly.

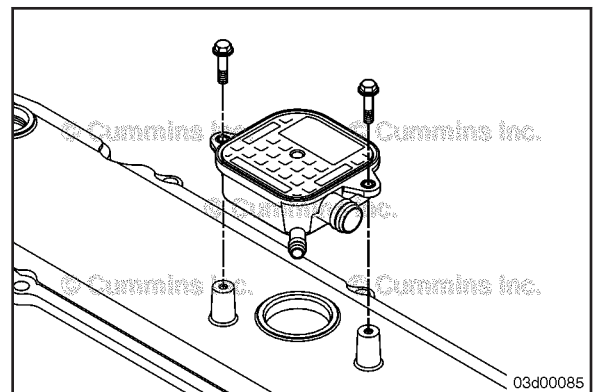

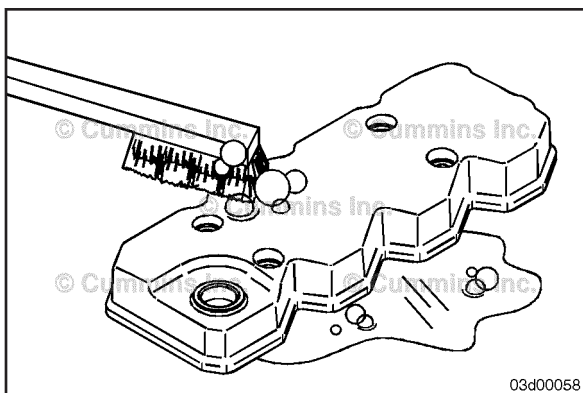

Clean and Inspect for Reuse

⚠ WARNING ⚠

When using solvents, acids, or alkaline materials for cleaning, follow the manufacturer's recommendations for use. Wear goggles and protective clothing to reduce the possibility of personal injury.

⚠ WARNING ⚠

Some solvents are flammable and toxic. Read the manufacturer's instructions before using.

⚠ WARNING ⚠

Wear appropriate eye and face protection when using compressed air. Flying debris and dirt can cause personal injury.

NOTE: When cleaning the rocker lever cover, if the rocker lever gasket is still installed in the base of the rocker lever cover, do **not** submerge the rocker lever cover in solvent. Limit the amount of exposure the gasket has to the solvent. The gasket is reusable. Once the gasket is removed from the rocker lever cover, it **must** be replaced.

Clean the rocker lever cover with solvent. Dry with compressed air.

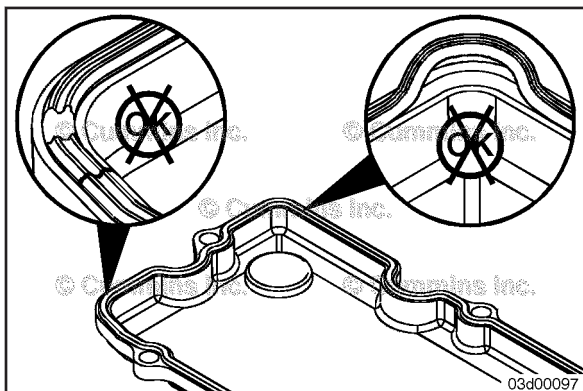

NOTE: Check the gasket while it is installed in the valve cover. Once the gasket is removed from the cover it **must** be replaced.

Check the gasket for cracks on the sealing surface.

Replace the gasket if damage is present.

Replace the gasket if it is removed from the groove in the rocker lever cover.

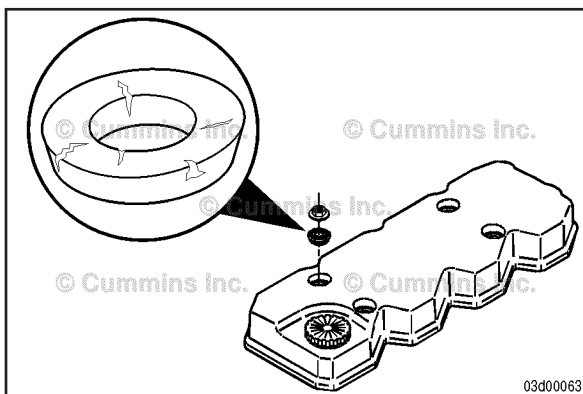

Stud Mounted Rocker Lever Cover.

Inspect the rubber isolators for cracks.

Replace if cracked or broken.

Capscrew Mounted Rocker Lever Cover.

Inspect the isolators for cracks, tears, or brittleness.

Inspect the capscrew for damage.

Replace the isolator and/or capscrew assembly if damage is found.

NOTE: It may be necessary to replace the capscrew/ isolator as an assembly.

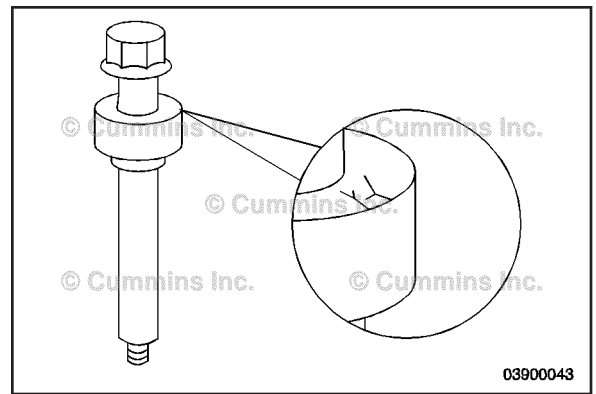

Inspect the rocker lever cover for cracks or other damage.

Replace the rocker lever cover if any damage is found.

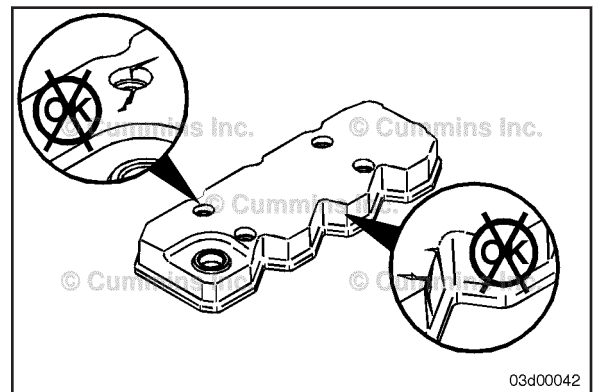

The rocker lever cover gasket is reusable. The gasket **must only** be replaced if damaged/leaking.

Inspect gasket wires. If any wire insulation is cracked or flaking off of the wires, replace the gasket.

Inspect the injector terminal posts and nuts for stripped threads. If stripped threads are present, replace the damaged injector(s).

Wipe the sealing surfaces of the rocker lever cover gasket with a clean shop towel.

Inspect the rocker lever cover gasket for tears or cracking. Replace if any damage is found.

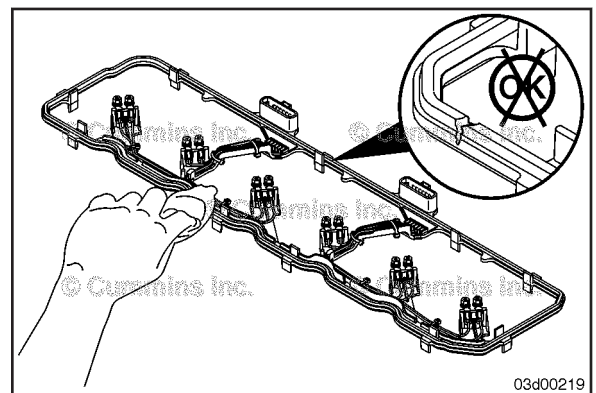

Assemble

External Mounted Crankcase Breather.

If removed, install the breather and mounting capscrews into the rocker lever cover.

Lubricate the o-ring and the rocker lever cover with lubricating oil.

Tighten the capscrews.

Torque Value: 10 N•m [89 in-lb]

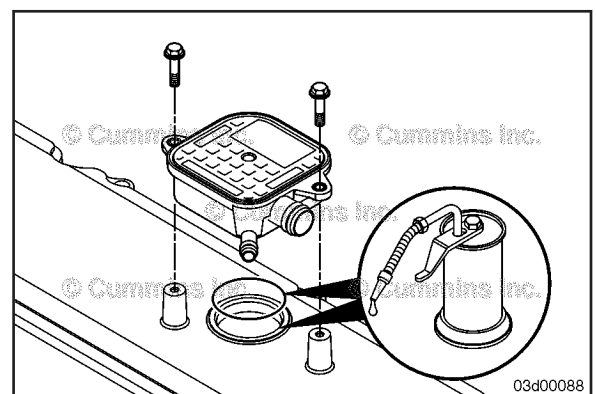

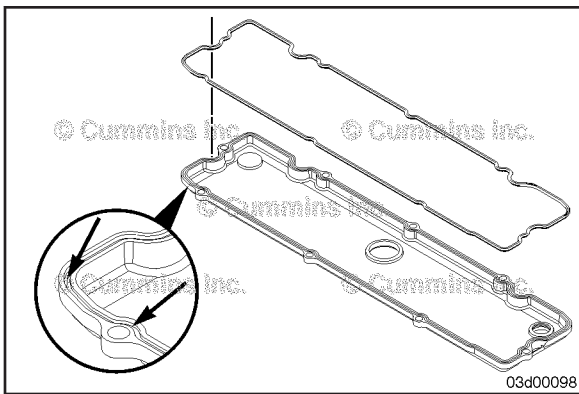

NOTE: If the gasket has been removed from the rocker lever cover, a new gasket **must** be used.

If replacing the rocker lever gasket, the following installation procedure **must** be used when installing the press-in gasket.

- 1 Press the molded gasket into the corners of the rocker lever cover
- 2 Press the remaining gasket into the rocker lever cover.

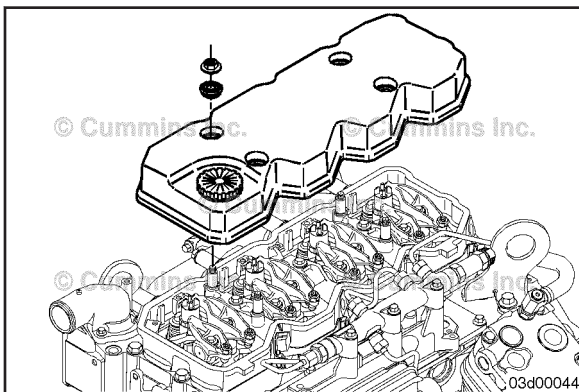

Install

Stud Mounted Rocker Lever Cover.



Install the rocker lever cover over the mounting capscrews.

Install the isolators and mounting nuts.

Tighten the mounting nuts.

Torque Value: 24 N•m [212 in-lb]

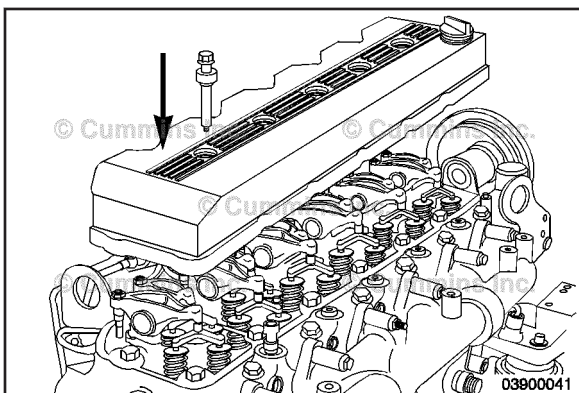

Capscrew Mounted Rocker Lever Cover.

Install the rocker lever cover.



Install the mounting capscrews and isolators.

Tighten the mounting capscrews.

Torque Value: 24 N•m [212 in-lb]

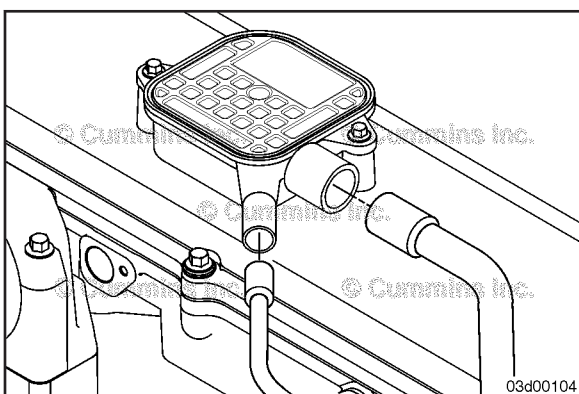

External Mounted Crankcase Breather.

Connect the crankcase breather tube to the crankcase breather assembly.

Connect the crankcase breather oil drain line to the crankcase breather assembly.

NOTE: It may be necessary to install an engine cover previously removed. Refer to the OEM instructions.

Internal Mounted Crankcase Breather.

If equipped, at the rear of the rocker lever cover install the banjo bolt and sealing washers connecting the breather oil drain line to the rocker lever cover.

Torque Value: 12 N•m [106 in-lb]

NOTE: Not all engines with an internal mounted crankcase breather are equipped with an external breather oil drain line. On some engines the breather oil drain line is internal to the breather connection tube (1).

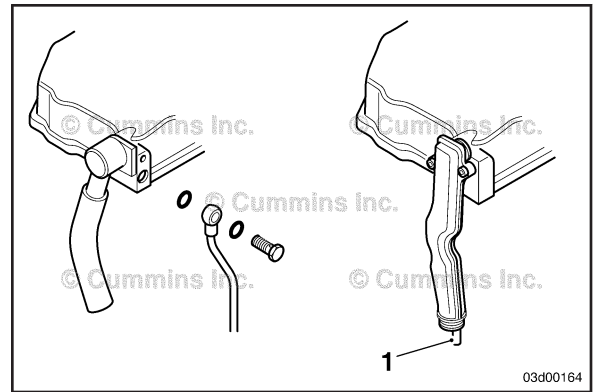

Prior to connecting the breather connection tube to the rocker lever cover, apply clean engine oil to the o-ring located on the breather tube connection.

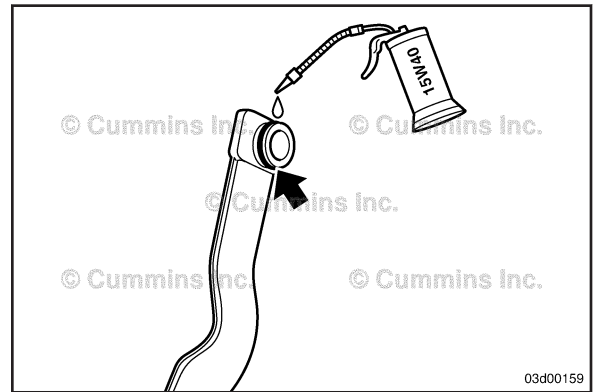

Connect the breather tube connection to the rocker lever cover.

In general, two types of breather tube connections are used at the rocker lever cover:

- 1 A clamping plate and capscrew hold the breather tube connection to the rocker lever cover. Install the capscrew and clamping plate to connect the breather tube connection to the rocker lever cover.
- 2 One or two capscrew(s) directly mount the breather tube connection to the rocker lever cover. Install the capscrew(s) to connect the breather tube connection to the rocker lever cover.

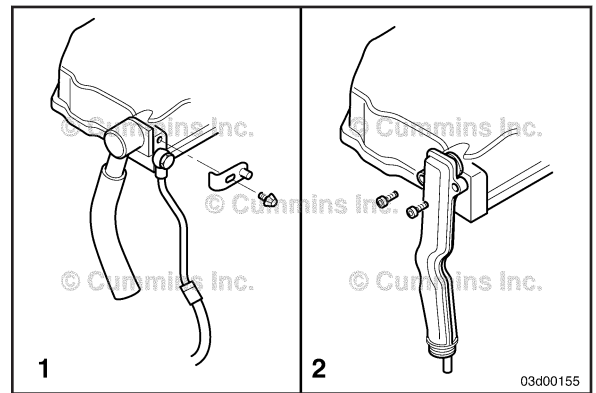

Tighten the capscrew(s).

Torque Value: 10 N•m [89 in-lb]

NOTE: Some breather tube connections use internal torx capscrews to secure the breather tube connection to the rocker lever cover.

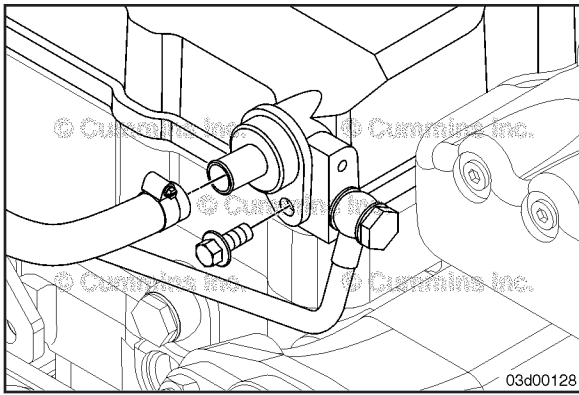

Marine Applications

Open Draft Tube Type

For the open draft tube type, install the cover plate and mounting capscrew.



Tighten the mounting capscrew.

Torque Value: 7 N•m [62 in-lb]

Install the crankcase breather tube and spring clamp.

Install the banjo bolt and sealing washers connecting the breather oil drain line to the rocker lever cover.

Tighten the banjo bolt.

Torque Value: 12 N•m [106 in-lb]

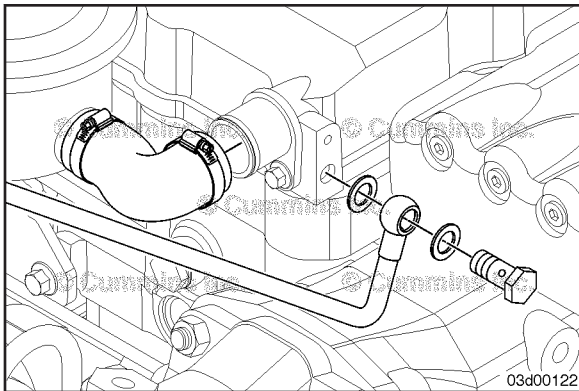

Closed Draft Tube Type

Connect the closed crankcase breather system hose to the rocker lever cover breather port.



Tighten the hose clamps.

Torque Value: 6 N•m [53 in-lb]

For the closed draft tube type, install the banjo bolt and sealing washer connecting the breather oil drain line to the rocker lever cover.

Tighten the banjo bolt.

Torque Value: 12 N•m [106 in-lb]

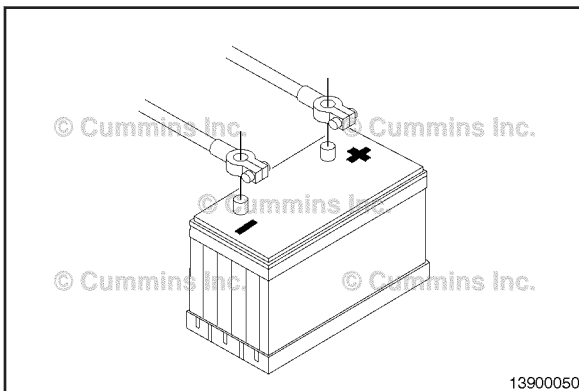

Finishing Steps

⚠ WARNING ⚠

Batteries can emit explosive gases. To reduce the possibility of personal injury, always ventilate the compartment before servicing the batteries. To reduce the possibility of arcing, remove the negative (-) battery cable first and attach the negative (-) battery cable last.

Connect the batteries. Refer to the OEM service manual.

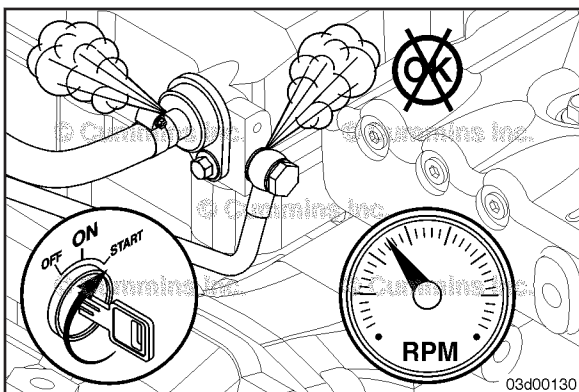

Operate the engine and check for leaks.

Rocker Lever Housing (003-013)

Remove

Disconnect the injector harness pass-through connector.

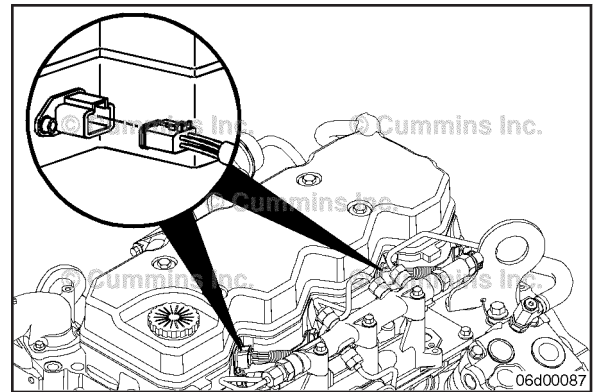

Remove the rocker lever cover. Refer to Procedure 003-011

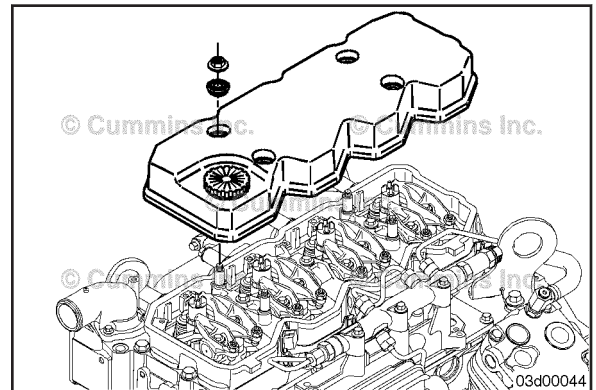

NOTE: It is **not** necessary to mark the injector solenoid wires.

Disconnect the injector wiring from the injector. Refer to Procedure 006-026

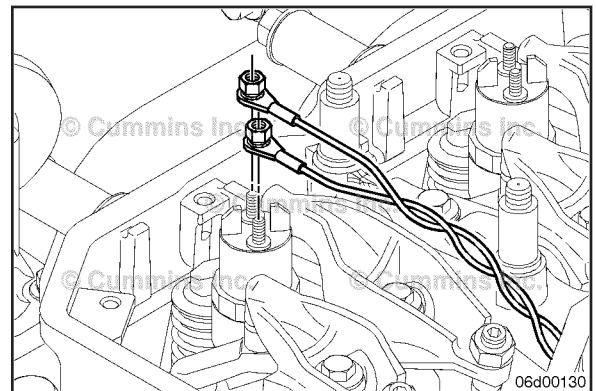

NOTE: Check the gasket while it is installed in the rocker housing. Once the gasket is removed it **must** be replaced.

NOTE: Check for cracks in the rocker housing bridge area before removing the mounting capscrews.

Remove the rocker housing, capscrews, and gasket.

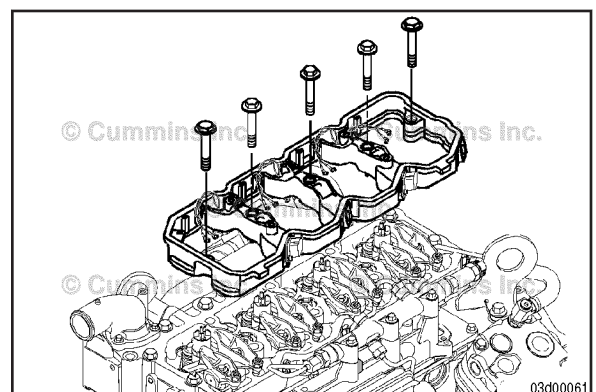

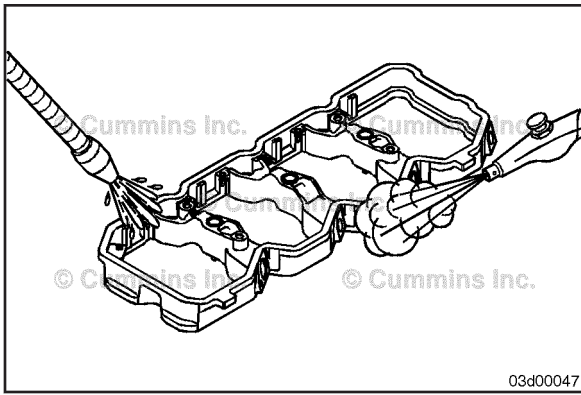

Clean

⚠ WARNING ⚠

When using solvents, acids, or alkaline materials for cleaning, follow the manufacturer's recommendations for use. Wear goggles and protective clothing to reduce the possibility of personal injury.

⚠ WARNING ⚠

Wear appropriate eye and face protection when using compressed air. Flying debris and dirt can cause personal injury.

Clean the rocker housing with solvent.

Dry the rocker housing with compressed air.

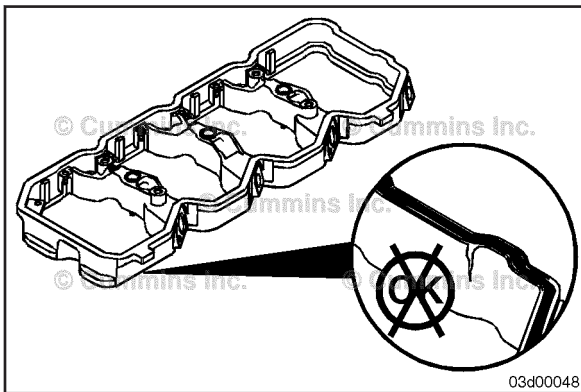

Inspect for Reuse

NOTE: Check the gasket while it is installed in the rocker housing. Once it is removed it **must** be replaced.

Inspect the rocker housing for cracks or any other damage, especially on the cylinder head mounting surface.

Check the gasket for cracks or is twisted in the groove.

Replace the gasket if it is torn, if cracks are present or it is twisted in the groove.

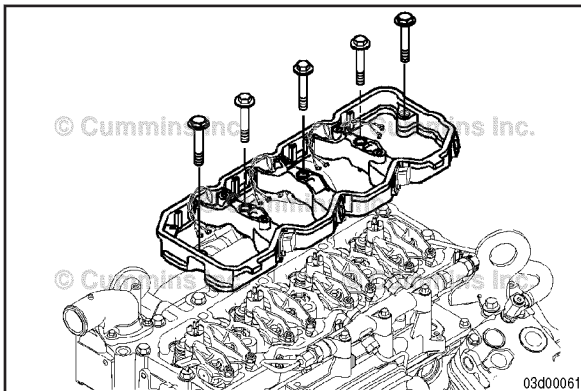

Install

⚠ CAUTION ⚠

Care must be taken when installing the gasket. Do not twist or stretch it. Failure to do so can result in an oil leak.

Install the rocker housing and a new rocker housing gasket, if removed.

Torque Value: 24 N•m [212 in-lb]

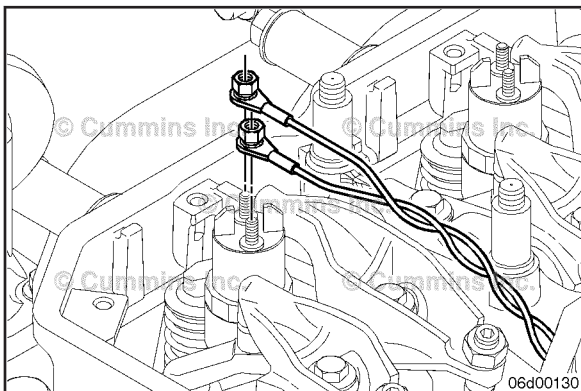

⚠ CAUTION ⚠

Overtightening of the injector wiring can cause damage to the injector.



Connect the injector wiring.

Use Cummins service tool, Part Number 3823208, or torque wrench.



Torque Value: 1.5 N•m [13 in-lb]

NOTE: If a torque wrench capable of 1.5 N•m [13 in-lb] is not available, then the following specification can be used. The alternate torque is finger-tighten with an additional 30-degree turn.

Install the rocker lever cover and gasket. Refer to Procedure 003-011

Torque Value: 24 N•m [212 in-lb]

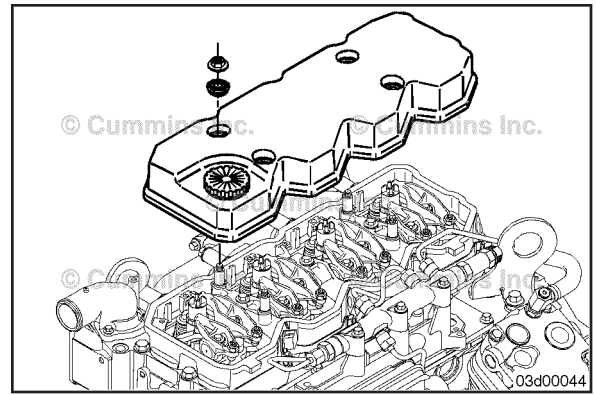

Connect the injector harness pass-through connector.

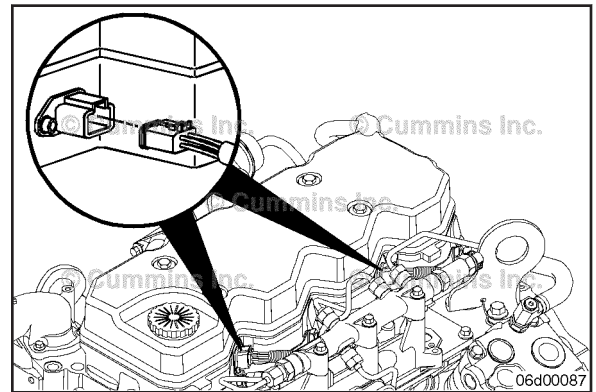

Crankcase Breather Tube (003-018)

General Information

Due to the number of crankcase breather tube configurations, the following procedure has been generalized to cover the majority of the engine configurations. The illustrations provided may **not** match the part that is being removed/installed.

Preparatory Steps

▲ WARNING ▲

Batteries can emit explosive gases. To reduce the possibility of personal injury, always ventilate the compartment before servicing the batteries. To reduce the possibility of arcing, remove the negative (-) battery cable first and attach the negative (-) battery cable last.

Disconnect the batteries.

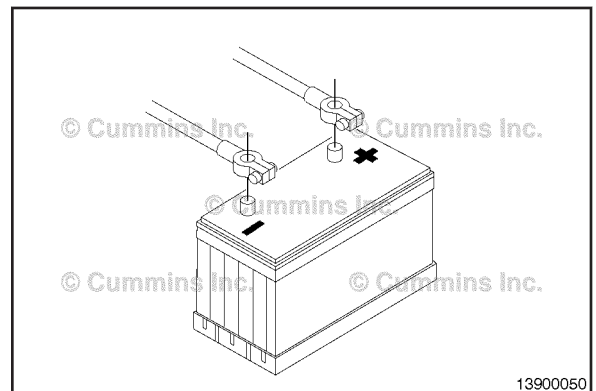

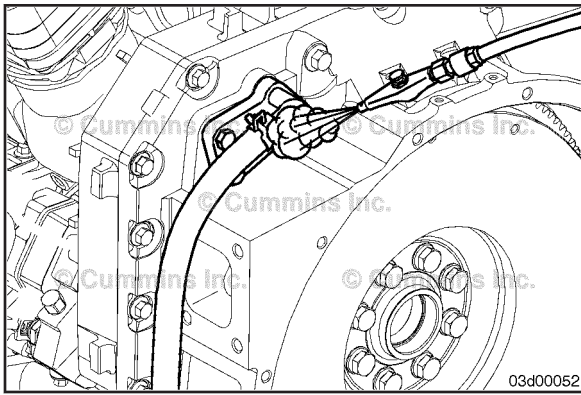

Remove

⚠ WARNING ⚠

Wear appropriate eye and face protection when using compressed air. Flying debris and dirt can cause personal injury.

Clean the area around the breather tube connection with compressed air.

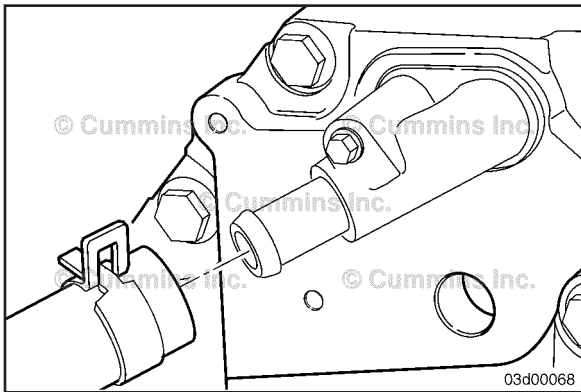

If equipped, remove and note the locations of any p-clips securing the crankcase breather tube.

Remove the hose clamp, if equipped, and disconnect the crankcase breather tube.

Remove the crankcase breather tube.

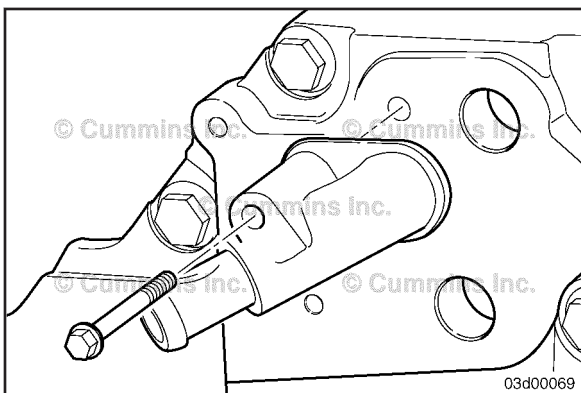

NOTE: On rear gear train engines, various adapters are used to connect the crankcase breather tube to the flywheel housing.

Breather Tube Adapter

Remove the one cap screw and the breather tube adapter located on the flywheel housing.

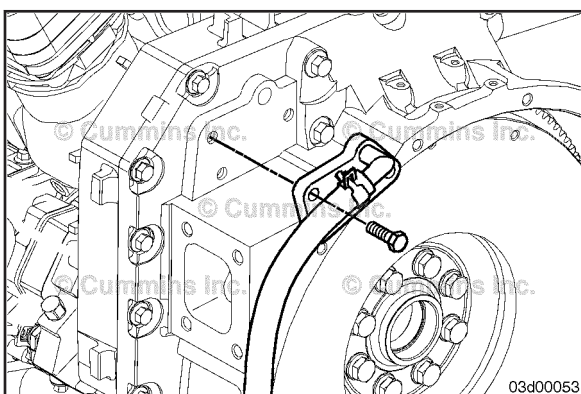

Breather Tube Mounting Plate Adapter

Remove the three cap screws and the breather tube mounting plate.

Clamp Plate Breather Tube Adapter

Remove the capscrew securing the clamp plate to the flywheel housing.

Remove the clamp plate.

Remove the breather tube adapter.

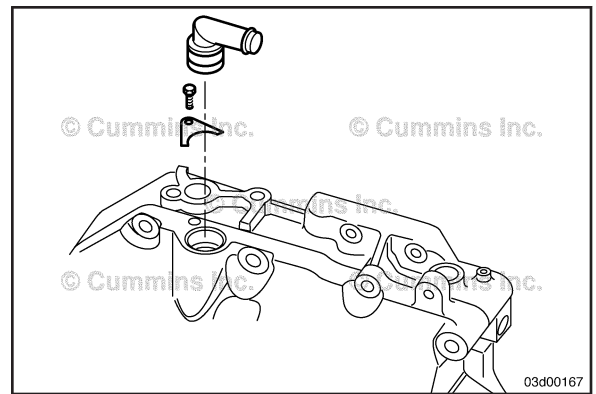

Clean and Inspect for Reuse

⚠ WARNING ⚠

Wear appropriate eye and face protection when using compressed air. Flying debris and dirt can cause personal injury.

Check the crankcase breather tube and adapter internally for obstructions or sludge buildup.

Clean with hot, soapy water and a soft brush.

Use compressed air to dry after rinsing in clean water.

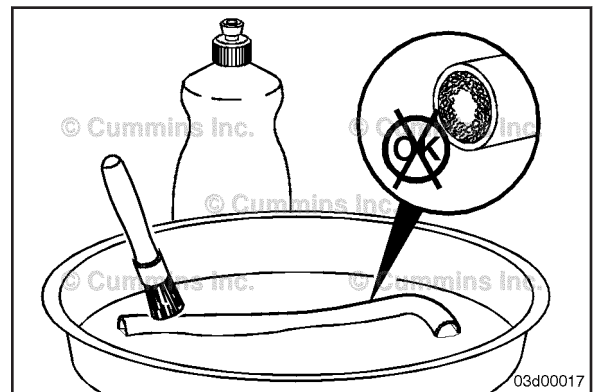

On components equipped with an o-ring seal, make sure to inspect the o-ring for cracks, tears, or brittleness.

If any damage is found, replace the o-ring.

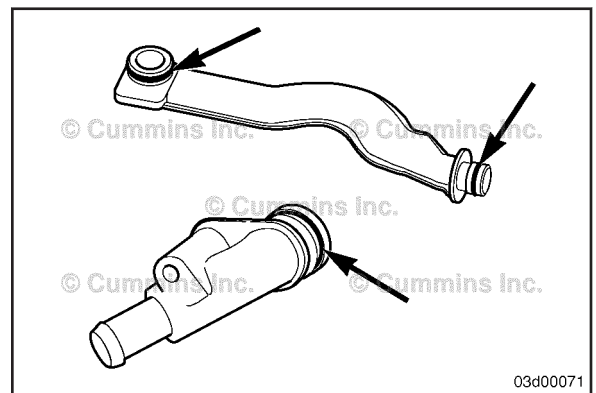

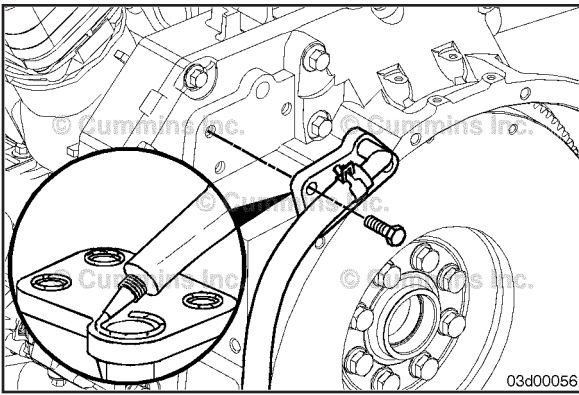

Install

Breather Tube Mounting Plate Adapter



⚠CAUTION⚠

Do not apply an excess amount of sealant. Excess sealant may block the crankcase gases and cause excess crankcase pressure buildup. Engine oil leaks will result.

If sealant was previously used on the breather tube mounting plate adapter, apply a 2-mm [0.08-in] bead of sealant, Part Number 3164067 to the cover plate.

If o-ring(s) were previously used, lubricate the o-ring(s) with clean engine oil.

Install the breather tube mounting plate, o-rings (if equipped) and capscrews.

Torque Value: 24 N•m [18 ft-lb]

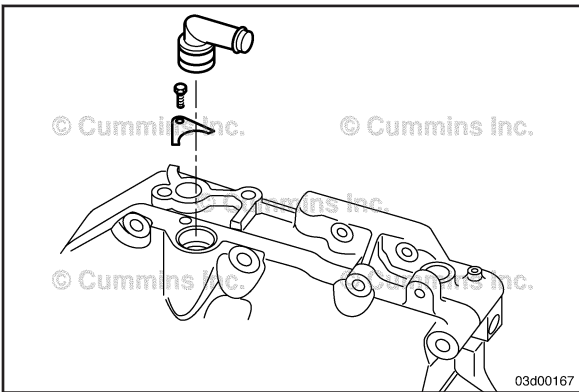

Clamp Plate Breather Tube Adapter

Lubricate the o-ring on the breather tube adapter with clean engine oil.



Install the breather tube adapter in the flywheel housing.

Install the cap screw and clamp plate to secure the breather tube adapter to the flywheel housing.

Torque Value: 24 N•m [18 ft-lb]

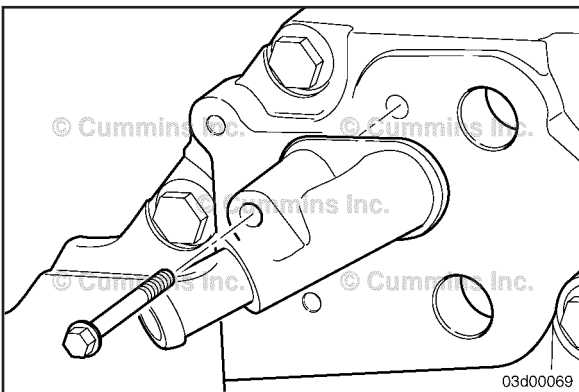

Breather Tube Adapter

Lubricate the o-ring on the breather tube adapter with clean engine oil.



Install the breather tube adapter into the flywheel housing.

Install the one cap screw and tighten.

Torque Value: 24 N•m [18 ft-lb]

Connect/install the crankcase breather tube.

If equipped, secure the crankcase breather tube with a hose clamp.

If equipped, install any p-clips previously removed, in the recorded locations, to secure the crankcase breather tube.

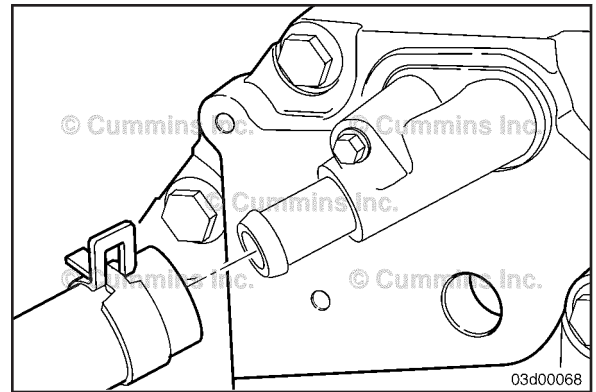

Finishing Steps



WARNING
Batteries can emit explosive gases. To reduce the possibility of personal injury, always ventilate the compartment before servicing the batteries. To reduce the possibility of arcing, remove the negative (-) battery cable first and attach the negative (-) battery cable last.

Connect the batteries.

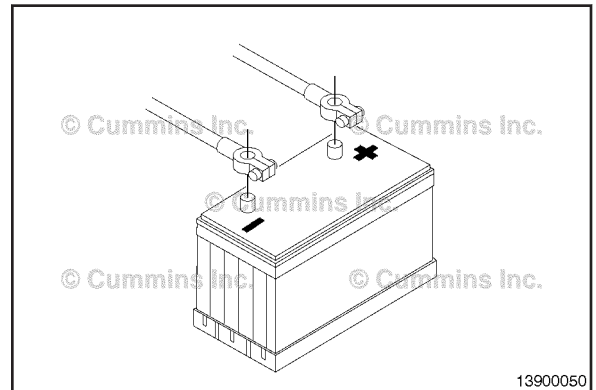

Operate the engine and check for leaks.

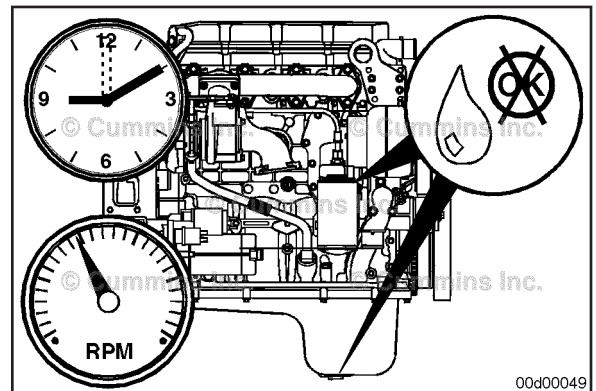

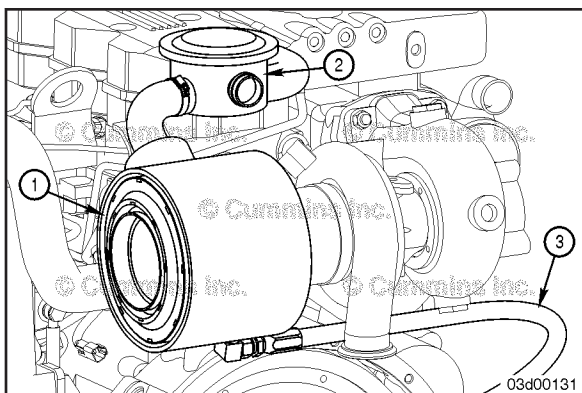

Closed-Crankcase Ventilation System Filter (003-020)

Initial Check

The closed-crankcase system has three major parts.

- 1 The air cleaner assembly (filters the incoming air) and a oil blow-by filter element called a coalescing filter.
- 2 Vacuum brake assembly; this keeps the engine from drawing oil directly into the turbocharger if the air cleaner is plugged.
- 3 Closed-crankcase drain plumbing; this includes the drain hoses and check valve. The check valve prevents crankcase pressure from flowing backwards in the air cleaner.

This procedure covers the closed-crankcase ventilation system filter **only**. Refer to Procedure 010-013 for instructions on removing, cleaning and inspecting, and installing other components of the complete assembly.

Check the restriction gauge on the air filter assembly. If the gauge is red, the air filter element **must** be cleaned or replaced. Refer to Procedure 010-013

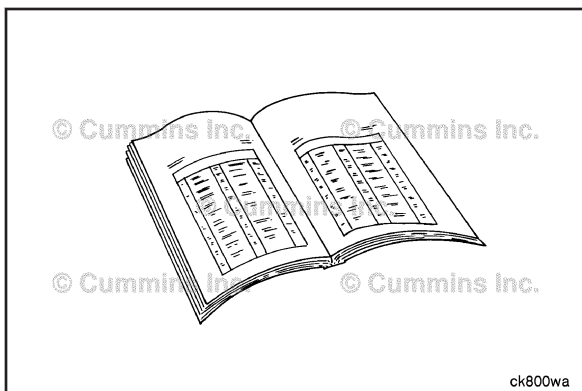

Preparatory Steps

Remove the air filter. Refer to Procedure 010-013

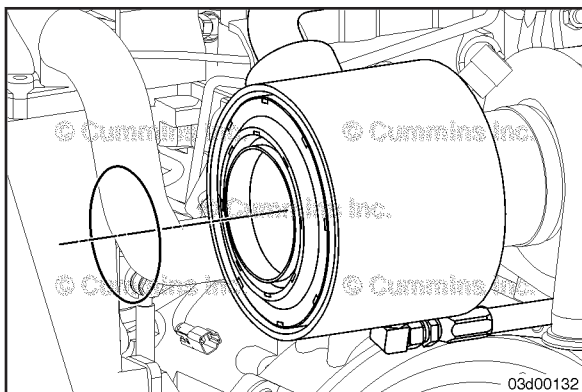

Remove

Remove the o-ring from the closed-crankcase breather element assembly.

Use a screwdriver in the notches around the element to break the seal and remove the element.

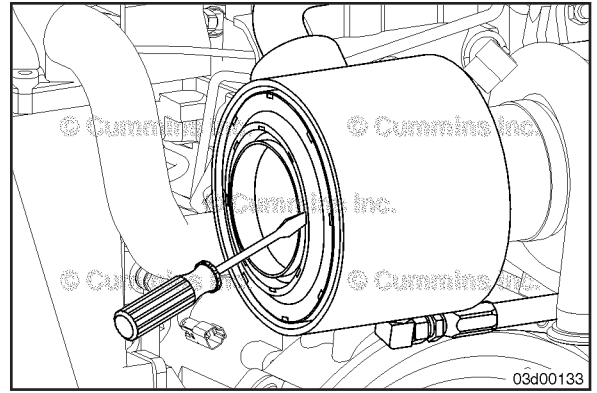

Remove the element from the canister.

NOTE: The filter will normally be oil soaked. Look for buildup of moisture condensation, sludge, or blockage of the element. Replace the element if it is dirty and oil soaked.

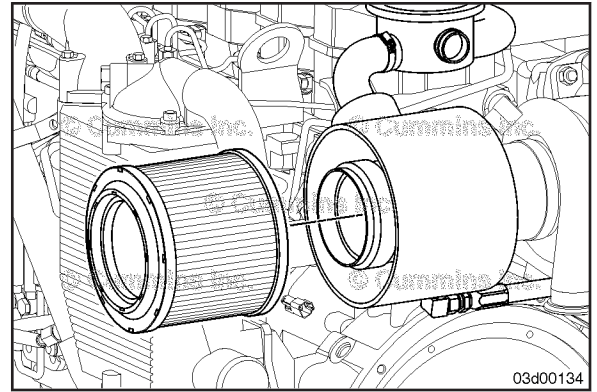

Clean and Inspect for Reuse

Use a clean rag to wipe the inside of the canister clean.

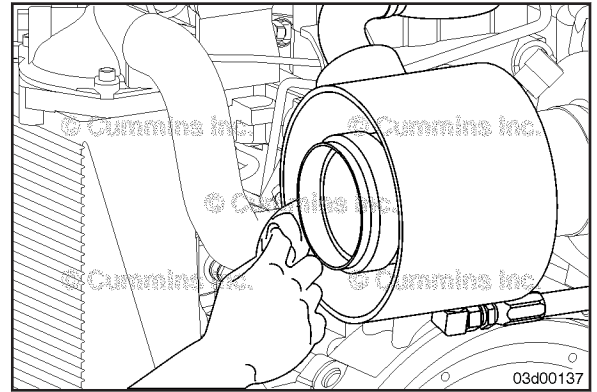

Inspect the canister for damage.

Inspect the o-rings for cuts or other damage.

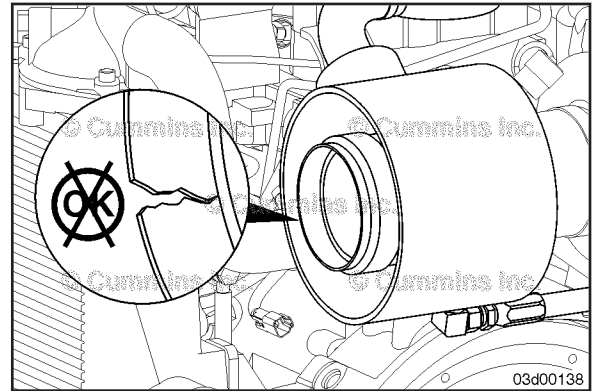

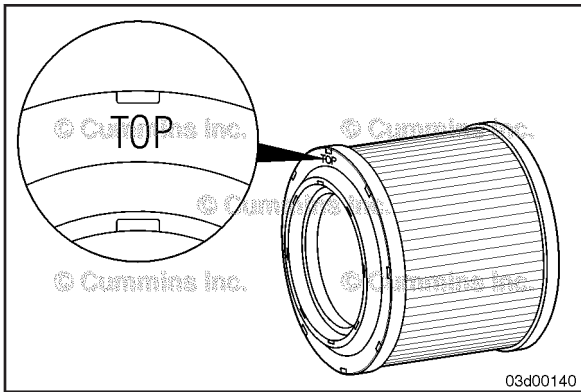

Install

The top of the filter is marked with "TOP" on the outer rim.

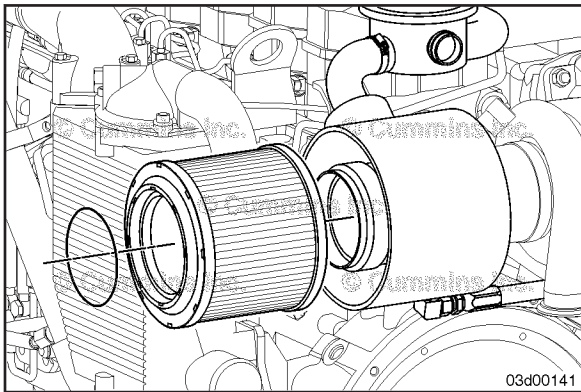

Install the clean filter into the canister.

Install the o-ring.

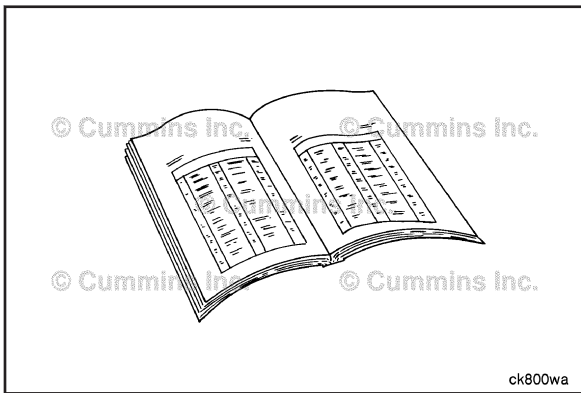

Finishing Steps

Install the air filter. Refer to Procedure 010-013

Operate the engine and check for leaks.

Section 4 - Cam Followers/Tappets - Group 04

Section Contents

	Page
Push Rods or Tubes	4-2
Clean.....	4-2
Inspect for Reuse.....	4-3
Install.....	4-3
Preparatory Steps.....	4-2
Remove.....	4-2
Service Tools	4-1
Cam Followers/Tappets.....	4-1
Tappet	4-4
Clean and Inspect for Reuse.....	4-7
Finishing Steps.....	4-10
General Information.....	4-4
Install.....	4-8
Remove.....	4-4

This Page Left Intentionally Blank

Service Tools

Cam Followers/Tappets

The following special tools are recommended to perform procedures in this section. The use of these tools is shown in the appropriate procedure. These tools can be purchased from a local Cummins® Authorized Repair Location.

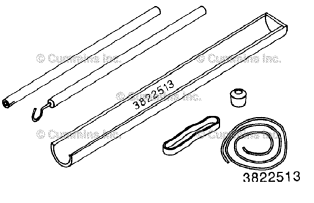
Tool No.	Tool Description	Tool Illustration
3822513	<p align="center">Tappet Replacement Kit</p> <p>Used to remove and install valve tappets.</p>	 <p>The illustration shows a collection of tools and components for a tappet replacement kit. It includes two long, thin metal rods, a shorter metal rod with a hook-like end, a small cylindrical cap, a curved metal piece, and a circular gasket or seal. The part number 3822513 is printed on the longer rods. Copyright notices for Cummins Inc. are also visible.</p>

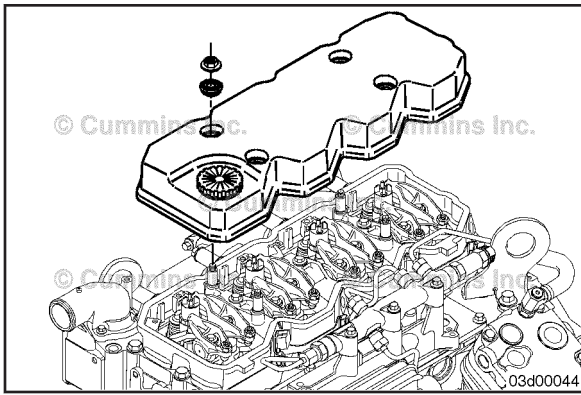

Push Rods or Tubes (004-014)

Preparatory Steps



Remove the rocker lever cover and gasket. Refer to Procedure 003-011

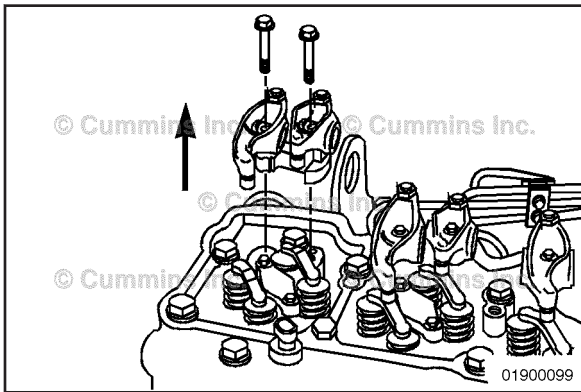

Remove the rocker levers. Refer to Procedure 003-008

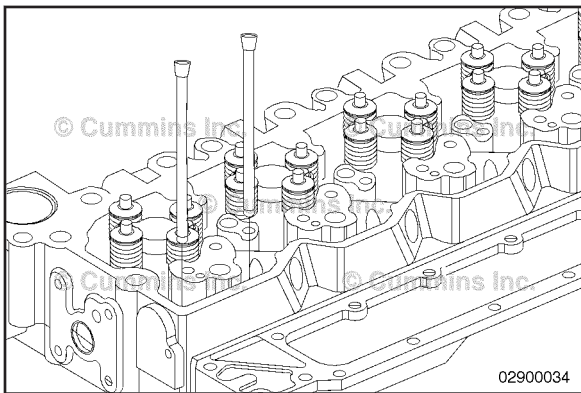

Remove

Mark the push rods to identify their location.

NOTE: The push rods **must** be installed in their original location and position.

Remove the push rods.

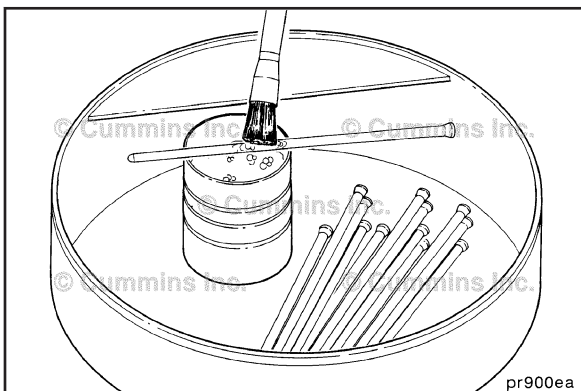

Clean

Clean the push tubes in hot, soapy water.

Inspect for Reuse

Inspect both ends of the push rods for wear, scores, or other damage.

Check for cracks where the ball and the socket are pressed into the tube.

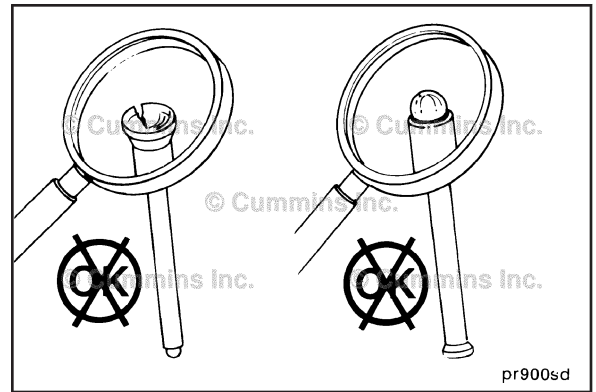

⚠ CAUTION ⚠

Do not use or try to straighten a bent push rod. Using a bent push rod can cause engine damage.

Check the straightness of the push rod by rolling it on a level surface.

Replace the push rod if it is bent.

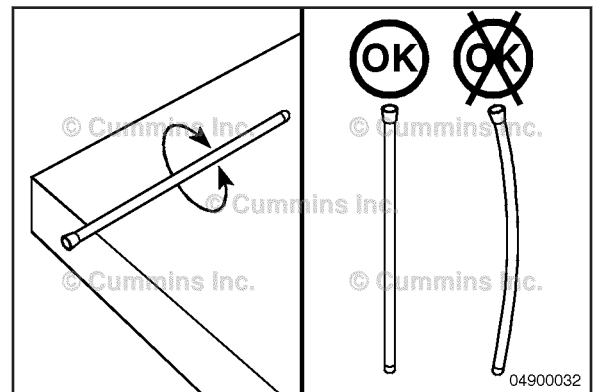

Install

Install the push rods into the sockets of the valve tappets.

Lubricate the push rod sockets with clean 15W-40 engine oil.

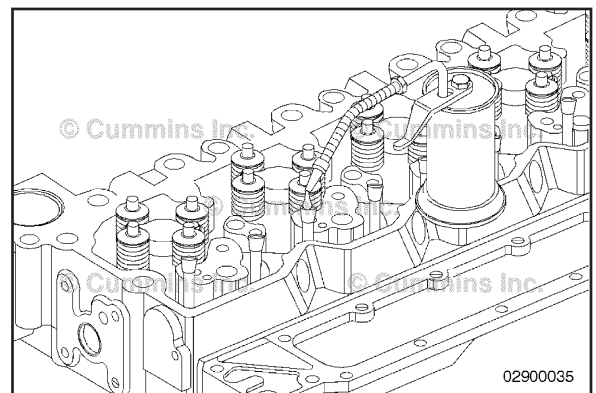

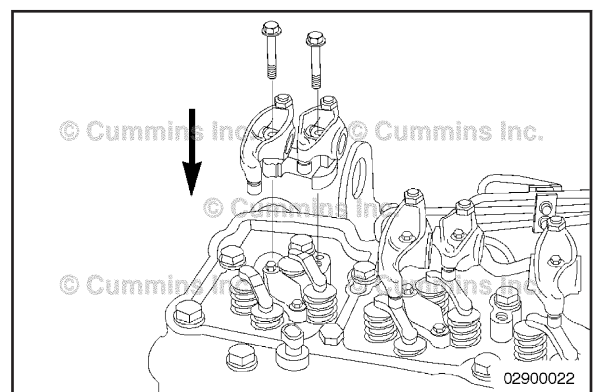

Install the crossheads and rocker levers. Refer to Procedure 003-008

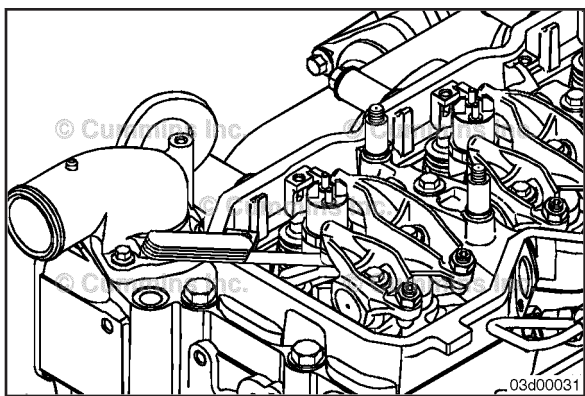

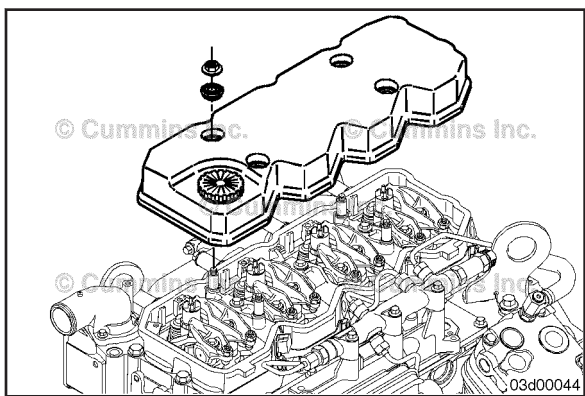

 Adjust the valves. Refer to Procedure 003-004



 Install the rocker lever cover and gasket. Refer to Procedure 003-011

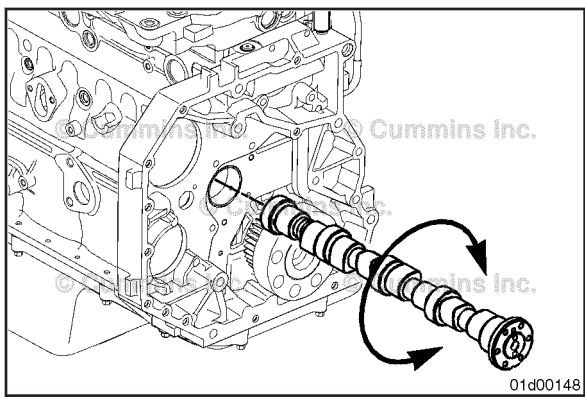

Tappet (004-015)

General Information

In order to remove the tappets from the engine, it is first necessary to start the removal process of the camshaft. Refer to Procedure 001-008, before following this procedure.

NOTE: Some of the graphics shown in this procedure are for rear gear train engines. However, the remove and install steps are the same for both rear gear train engines and front gear train engines.

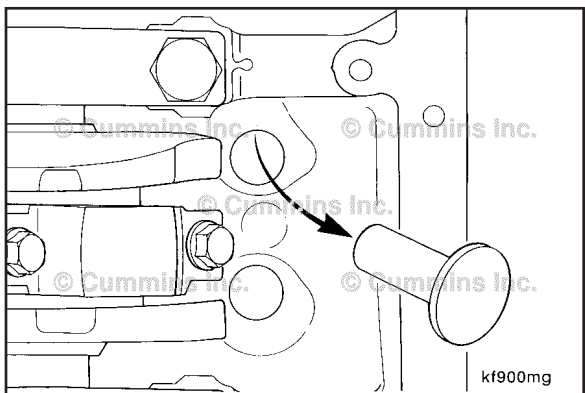

Remove

With the camshaft removed, remove the tappets through the bottom of the engine.

Mark the position of the tappets as they are removed. If reused, the tappets **must** be installed in the same position when the engine is assembled.

Use tappet removal tool kit, Part Number 3822513, to remove the tappets.

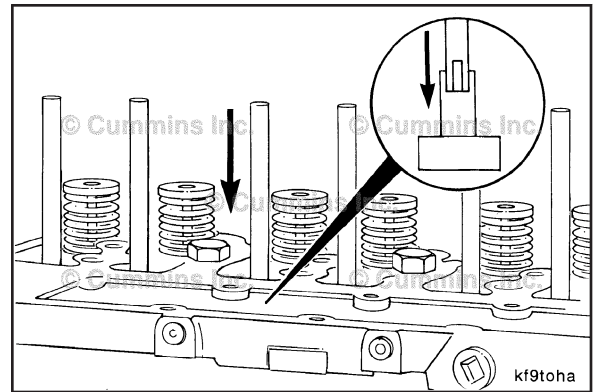

Push a wooden dowel rod into each tappet. It will probably be necessary to push the dowel into the tappet with a soft-face hammer.

NOTE: When properly installed, the dowels can be used to pull the tappets up and should require considerable effort to be pulled out.

Pull each valve tappet up until it makes contact with the cylinder block. Put a rubber band around two dowels. This will hold the tappets up off the camshaft.

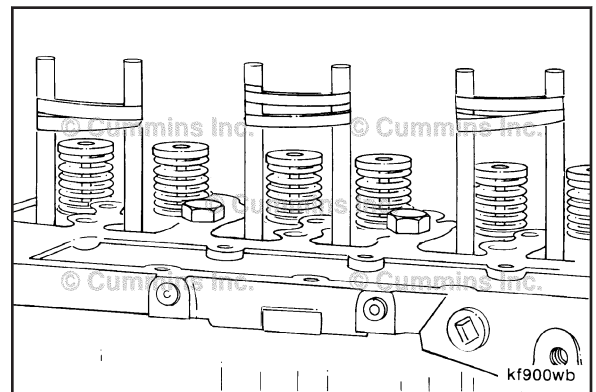

Remove the camshaft. Refer to Procedure 001-008

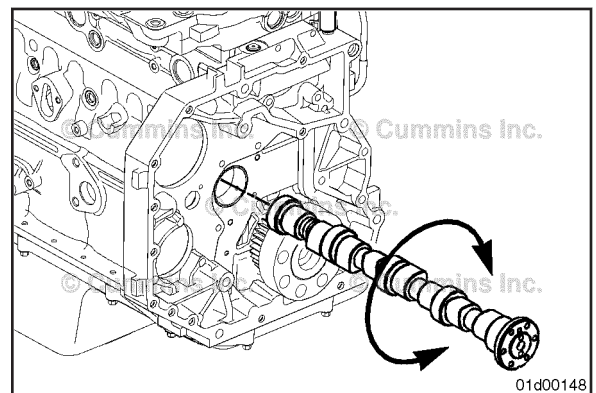

Insert the trough from the tappet replacement kit, Part Number 3822513, to the full length of the cam bore.



NOTE: Make sure the trough is positioned so that it will catch the tappet when the wooden dowel is removed.

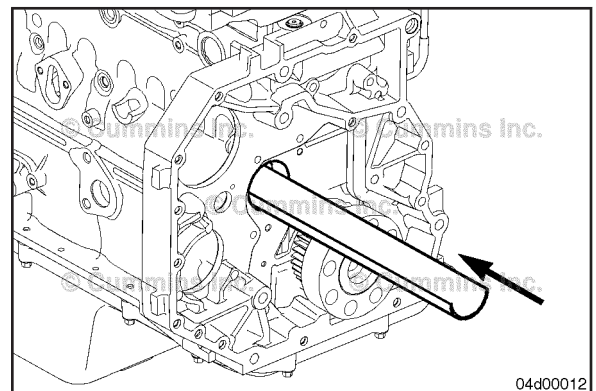

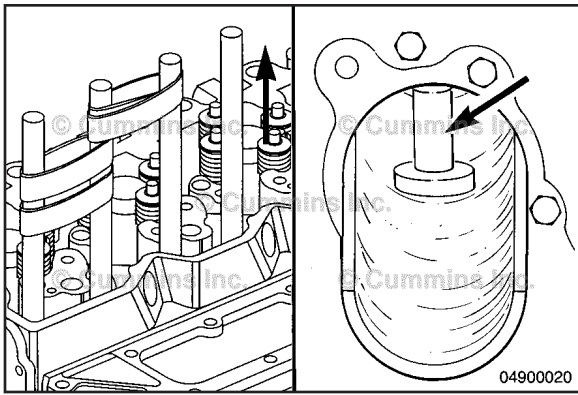

Only remove one tappet at a time.

Mark the position of the tappets as they are removed. The tappets **must** be installed in the same position when the engine is assembled.

Remove the rubber band from the two companion tappets.

Secure the tappet that is **not** to be removed with the rubber band.

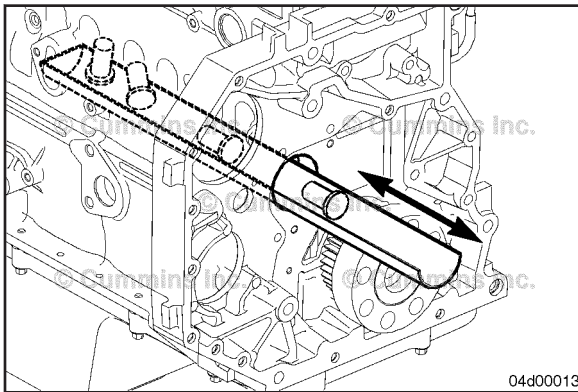

NOTE: When the tappet is dropped into the trough, most of the time it will fall over. However, if it does **not**, gently shake the trough just enough to allow the tappet to fall over before removing.

Pull the wooden dowel from the tappet bore, allowing the tappet to fall into the trough.

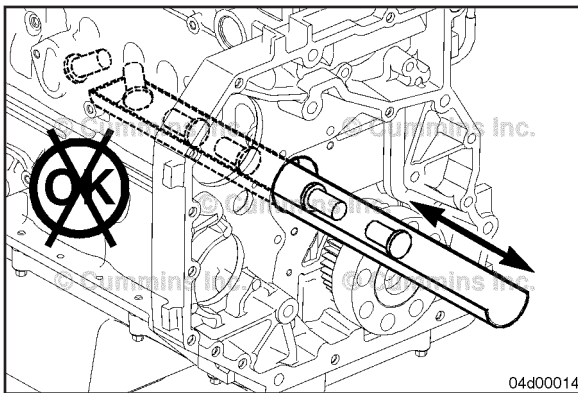

Take special care **not** to knock or shake the tappets over the end of the trough.

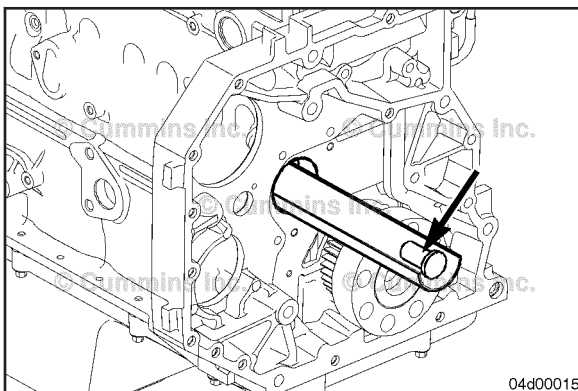

Carefully pull the trough and tappet from the cam bore, and remove the tappet. Repeat the process until all tappets are removed.

Clean and Inspect for Reuse

⚠ WARNING ⚠

When using solvents, acids, or alkaline materials for cleaning, follow the manufacturer's recommendations for use. Wear goggles and protective clothing to reduce the possibility of personal injury.

Clean the tappets with solvent.

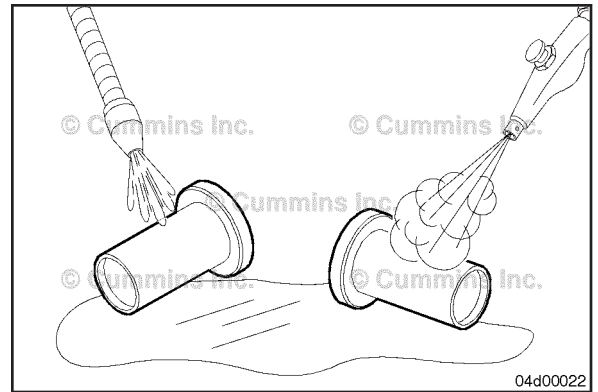

Inspect the socket, stem, and face for excessive wear, cracks, and other damage.

- Normal contact (exaggerated)
- Irregular contact - do **not** reuse
- Irregular contact - do **not** reuse.

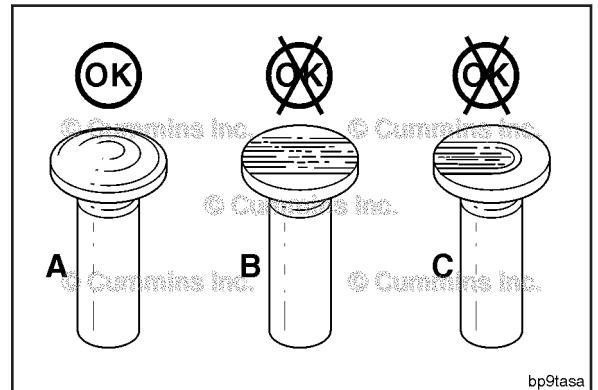

Pit marks on the tappet face are acceptable.

The following criteria define the size of the pits allowed.

- A single pit can **not** be greater than 2 mm [0.079 in].
- Interconnection of pits is **not** allowed.
- Total pits when added together should **not** exceed 6-mm [0.236-in] diameter or a total of 4 percent of the tappet face.
- No pitting is allowed on the edges of the wear face of the tappet.

For detailed illustrations and reuse guidelines, refer to Service Bulletin 3666475, Camshaft and Tappet Reuse Guidelines.

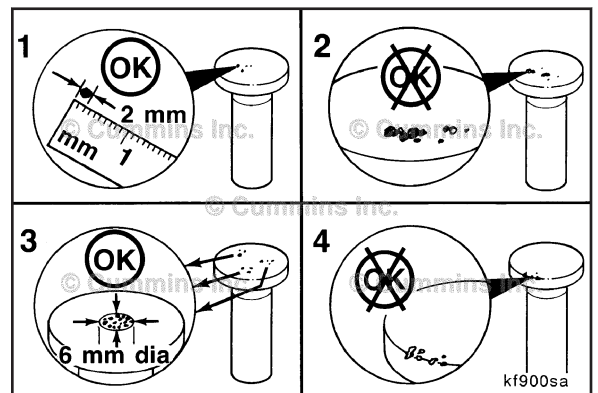

Measure the valve tappet stem.

Valve Tappet Stem Diameter

mm		in
15.936	MIN	0.627
15.977	MAX	0.629

If the tappet stem is **not** within specifications, replace the tappet. Make sure to inspect the tappet bore for wear. Refer to Procedure 001-026

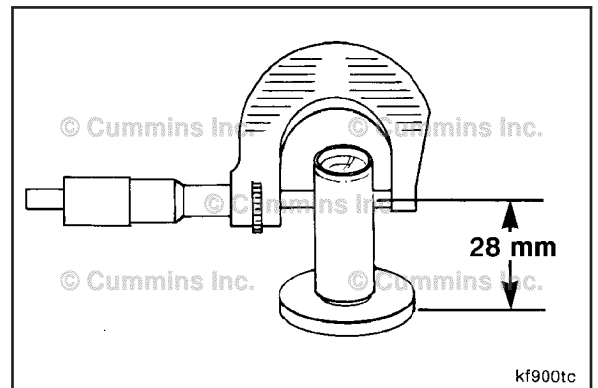

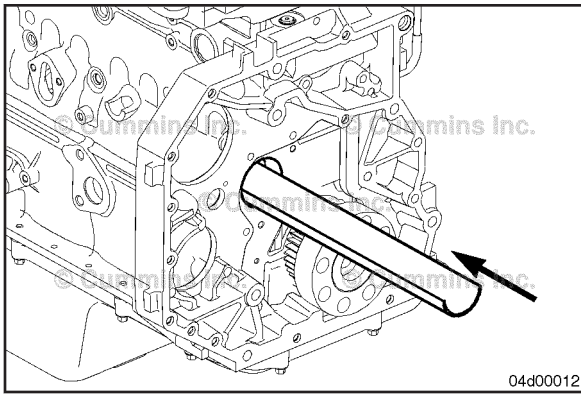

Install

Insert the trough from the tappet replacement kit, Part Number 3822513, the full length of the cam bore.

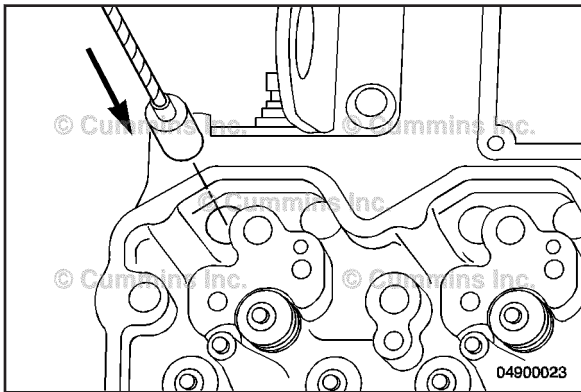

Lower the tappet installation tool down through the push tube hole, through the tappet bore, and into the trough.

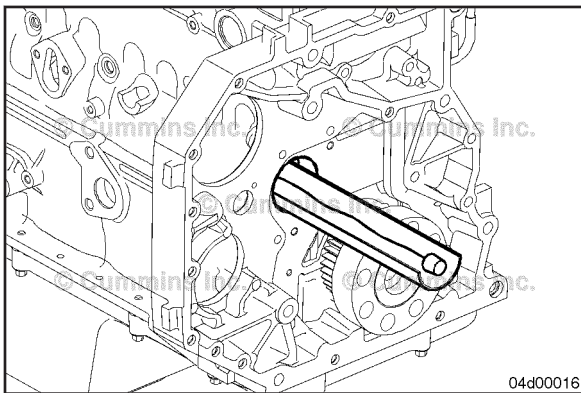

Feed the installation tool through the cam bores by carefully pulling the trough/installation tool out the front of the engine. The barrier at the rear of the trough will pull the tool out **most** of the time.

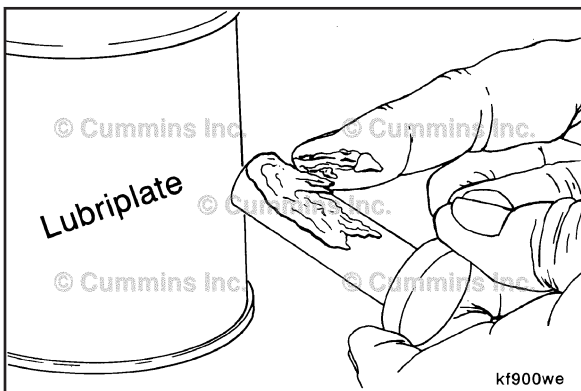

Lubricate the tappets with assembly lubricant, Part Number 3163087, or equivalent.

To aid in removing the installation tool after the tappet is installed, work the tool in and out of the tappet several times **before** installing the tappets.



Insert the installation tool into the tappet.

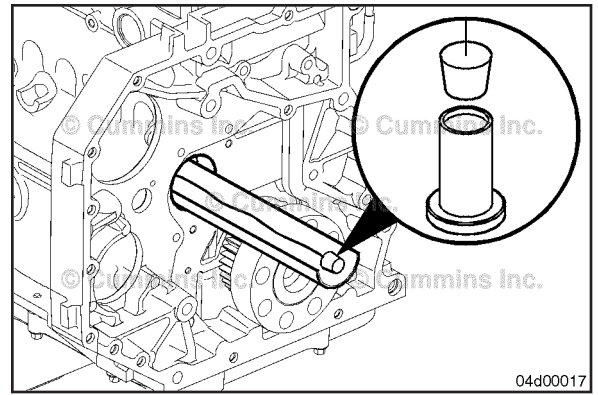

Slide the trough into the cam bore.

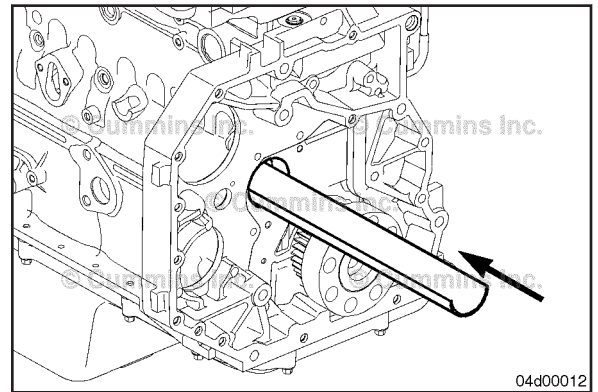

Pull the tool and tappet through the cam bore and up into the tappet bore.

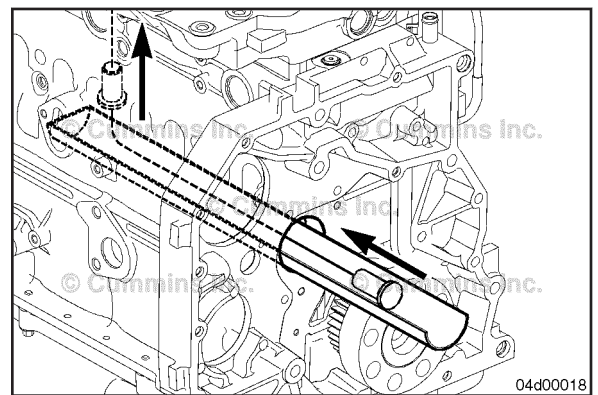

If difficulty is experienced in getting the tappet to make the bend from the trough up to the tappet bore, pull the trough out enough to allow the tappet to drop down and align itself.



Pull the tappet up into the bore.

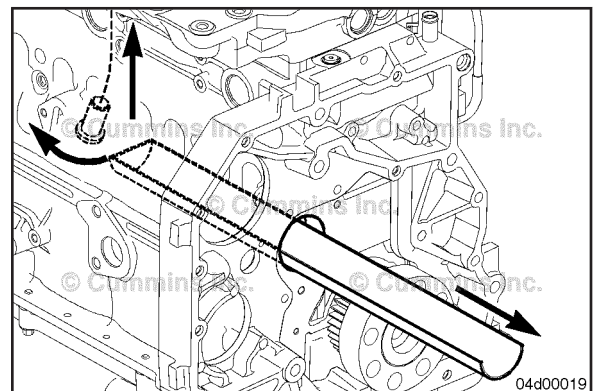

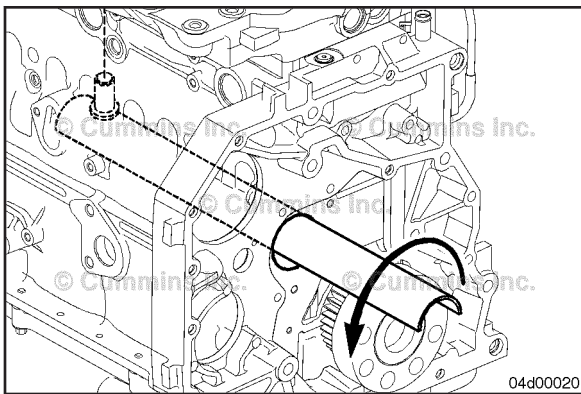

After the tappet has been pulled up into position, slide the trough back into the cam bore, and rotate it $\frac{1}{2}$ of a turn. This will position the round side of the trough up, which will hold the tappet in place.

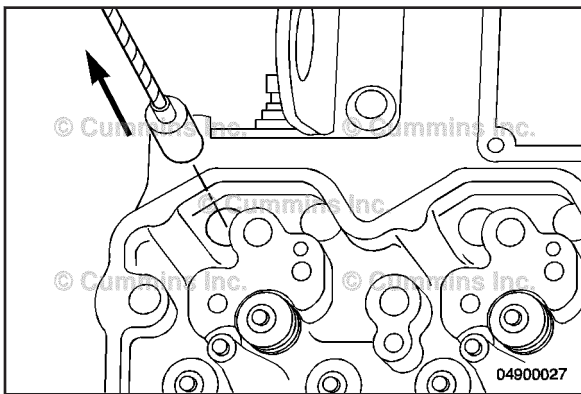

Remove the installation tool from the tappet.

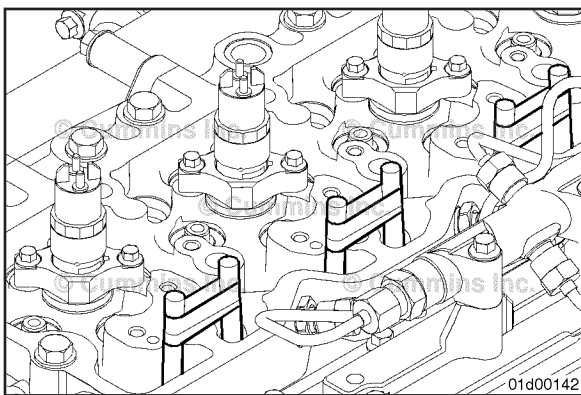

Install a wooden dowel into the top of the tappet.

Wrap rubber bands around the wooden dowels to secure the tappets.

Repeat this process until all tappets have been installed.

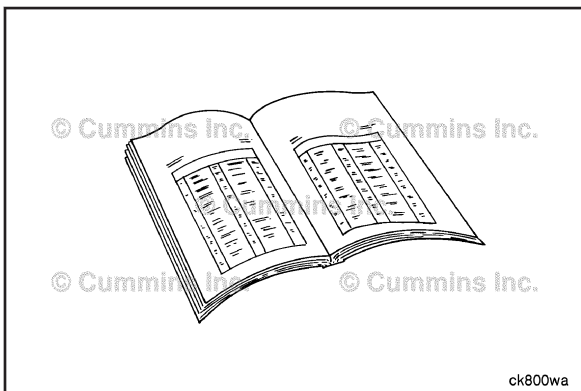

Finishing Steps

Install the camshaft. Refer to Procedure 001-008

About the Manual	i-1	Finishing Steps.....	1-199
General Information.....	i-1	Install.....	1-199
Accessory Drive	DS-18	Preparatory Steps.....	1-197
Remove.....	DS-18	Remove.....	1-198
Accessory Drive	AS-34	Camshaft	DS-53
Initial Check.....	AS-34	Remove.....	DS-53
Install.....	AS-35	Camshaft	AS-17
Acronyms and Abbreviations	i-17	Install.....	AS-17
General Information.....	i-17	Camshaft	1-25
Air Compressor	DS-19	Assemble.....	1-33
Remove.....	DS-19	Clean and Inspect for Reuse.....	1-30
Time.....	DS-19	Disassemble.....	1-30
Air Compressor	AS-32	Finishing Steps.....	1-38
Install.....	AS-33	Initial Check.....	1-25
Time.....	AS-32	Install.....	1-34
Air Compressor Air Pressure Rises Slowly	TS-14	Measure.....	1-32
Air Compressor Cycles Frequently.....	TS-15	Preparatory Steps.....	1-26
Air Compressor Noise is Excessive.....	TS-16	Remove.....	1-28
Air Compressor Pumping Excess Lubricating Oil into the Air System	TS-17	Camshaft Bushings	DS-61
Air Compressor Will Not Maintain Adequate Air Pressure (Not Pumping		Remove.....	DS-61
Continuously).....	TS-19	Camshaft Bushings	AS-1
Air Compressor Will Not Pump Air.....	TS-20	Install.....	AS-1
Air Compressor Will Not Stop Pumping.....	TS-22	Camshaft Bushings	1-40
Air Intake Connection	DS-26	Finishing Steps.....	1-43
Remove.....	DS-26	General Information.....	1-40
Air Intake Connection	AS-51	Initial Check.....	1-41
Install.....	AS-51	Inspect for Reuse.....	1-42
Air Intake Connection Adapter	DS-25	Install.....	1-42
Remove.....	DS-25	Measure.....	1-43
Air Intake Connection Adapter	AS-53	Preparatory Steps.....	1-40
Install.....	AS-53	Remove.....	1-42
Air Intake Manifold	DS-35	Camshaft Gear (Camshaft Installed)	DS-53
Remove.....	DS-35	Remove.....	DS-53
Air Intake Manifold	AS-37	Camshaft Gear (Camshaft Installed)	AS-20
Install.....	AS-37	Install.....	AS-20
Air Intake System - Overview	F-38	Camshaft Gear (Camshaft Installed)	1-44
General Information.....	F-38	Clean and Inspect for Reuse.....	1-46
Alternator	DS-4	Finishing Steps.....	1-49
Remove.....	DS-4	General Information.....	1-44
Alternator	AS-94	Install.....	1-47
Install.....	AS-94	Measure.....	1-48
Alternator Bracket	DS-6	Preparatory Steps.....	1-45
Remove.....	DS-6	Remove.....	1-45
Spool Mount.....	DS-6	Camshaft Gear (Camshaft Removed)	1-49
Pad Mount.....	DS-6	Clean and Inspect for Reuse.....	1-51
Marine Applications.....	DS-6	General Information.....	1-49
Alternator Bracket	AS-93	Install.....	1-52
Install.....	AS-93	Measure.....	1-52
Spool Mount.....	AS-93	Remove.....	1-50
Pad Mount.....	AS-93	Closed-Crankcase Ventilation System Filter	3-38
Marine Applications.....	AS-94	Clean and Inspect for Reuse.....	3-39
Alternator Not Charging or Insufficient Charging.....	TS-23	Finishing Steps.....	3-40
Alternator Overcharging.....	TS-25	Initial Check.....	3-38
Balancer	1-5	Install.....	3-40
Assemble.....	1-6	Preparatory Steps.....	3-38
Clean.....	1-6	Remove.....	3-38
Disassemble.....	1-5	Complete Engine - Overview	F-1
Finishing Steps.....	1-8	General Information.....	F-1
Inspect for Reuse.....	1-6	Compressed Air System - Overview	F-51
Install.....	1-7	General Information.....	F-51
Preparatory Steps.....	1-5	Connecting Rod	1-54
Remove.....	1-5	Clean and Inspect for Reuse.....	1-56
Bearings, Connecting Rod	1-8	Finishing Steps.....	1-60
Clean and Inspect for Reuse.....	1-11	General Information.....	1-54
Finishing Steps.....	1-14	Preparatory Steps.....	1-55
General Information.....	1-8	Coolant in the Lubricating Oil.....	TS-38
Install.....	1-13	Coolant Loss - External.....	TS-26
Preparatory Steps.....	1-9	Coolant Loss - Internal.....	TS-28
Remove.....	1-9	Coolant Temperature Above Normal - Gradual Overheat.....	TS-29
Bearings, Main	1-15	Coolant Temperature Above Normal - Sea Water Cooling System.....	TS-39
Clean and Inspect for Reuse.....	1-17	Coolant Temperature Above Normal - Sudden Overheat.....	TS-33
Finishing Steps.....	1-25	Coolant Temperature Below Normal.....	TS-36
Initial Check.....	1-15	Coolant Thermostat Housing	DS-7
Install.....	1-20	General Information.....	DS-7
Measure.....	1-19	Remove.....	DS-8
Preparatory Steps.....	1-15	Coolant Thermostat Housing	AS-91
Remove.....	1-16	General Information.....	AS-91
Belt Guard	DS-1	Install.....	AS-91
Remove.....	DS-1	Coolant Thermostat Housing Support	DS-8
Belt Guard	AS-99	General Information.....	DS-8
Install.....	AS-99	Remove.....	DS-8
Block Stiffener Plate	DS-52	Coolant Thermostat Housing Support	AS-91
Remove.....	DS-52	General Information.....	AS-91
Block Stiffener Plate	AS-21	Install.....	AS-91
Install.....	AS-21	Coolant Vent Lines	DS-7
Block Stiffener Plate	1-197	Remove.....	DS-7
Clean and Inspect for Reuse.....	1-198	Coolant Vent Lines	AS-92

Index
Page X-2

Install.....	AS-92	Clean and Inspect for Reuse.....	1-196
Cooling System - Overview	F-31	Finishing Steps.....	1-197
General Information.....	F-31	General Information.....	1-195
Crankcase Breather (External)	DS-18	Install.....	1-196
Remove.....	DS-18	Measure.....	1-196
Crankcase Breather (External)	AS-69	Preparatory Steps.....	1-195
Install.....	AS-69	Remove.....	1-195
Crankcase Breather (External)	3-2	Crankshaft Wear Sleeve, Front	1-101
Clean and Inspect for Reuse.....	3-3	Clean and Inspect for Reuse.....	1-103
Finishing Steps.....	3-5	Finishing Steps.....	1-107
General Information.....	3-2	General Information.....	1-101
Install.....	3-4	Install.....	1-104
Preparatory Steps.....	3-2	Preparatory Steps.....	1-101
Remove.....	3-2	Remove.....	1-103
Crankcase Breather (Internal)	DS-16	Crankshaft Wear Sleeve, Rear	DS-15
Remove.....	DS-16	Remove.....	DS-15
Crankcase Breather (Internal)	AS-69	Crankshaft Wear Sleeve, Rear	AS-72
Install.....	AS-69	Install.....	AS-72
Crankcase Breather (Internal)	3-5	Crankshaft Wear Sleeve, Rear	1-186
Clean and Inspect for Reuse.....	3-8	Clean and Inspect for Reuse.....	1-189
Finishing Steps.....	3-11	Finishing steps.....	1-193
General Information.....	3-5	General Information.....	1-186
Install.....	3-9	Install.....	1-190
Preparatory Steps.....	3-5	Preparatory steps.....	1-187
Remove.....	3-6	Remove.....	1-188
Crankcase Breather Tube	DS-12	Crosshead	DS-24
Remove.....	DS-12	Remove.....	DS-24
Crankcase Breather Tube	AS-77	Crosshead	AS-63
Install.....	AS-77	Install.....	AS-63
Crankcase Breather Tube	3-33	Crosshead	2-4
Clean and Inspect for Reuse.....	3-35	Clean and Inspect for Reuse.....	2-4
Finishing Steps.....	3-37	Finishing Steps.....	2-5
General Information.....	3-33	Install.....	2-5
Install.....	3-36	Preparatory Steps.....	2-4
Preparatory Steps.....	3-33	Remove.....	2-4
Remove.....	3-34	Cummins® Service Engine Model Product Identification	E-45
Crankcase Gases (Blowby) Excessive.....	TS-40	General Information.....	E-45
Cranking Fuel Pressure is Low.....	TS-42	Cylinder Block	1-108
Crankshaft	DS-60	Clean and Inspect for Reuse.....	1-109
Remove.....	DS-60	Finishing Steps.....	1-128
Crankshaft	AS-2	General Information.....	1-108
Install.....	AS-2	Initial Check.....	1-108
Crankshaft	1-60	Measure.....	1-113
Clean and Inspect for Reuse.....	1-63	Preparatory Steps.....	1-109
Finishing Steps.....	1-75	Repair.....	1-118
General Information.....	1-60	Cylinder Block - Overview	F-1
Initial Check.....	1-68	General Information.....	F-1
Install.....	1-69	Cylinder Head	DS-49
Measure.....	1-65	Remove.....	DS-49
Preparatory Steps.....	1-61	Cylinder Head	AS-28
Remove.....	1-62	Install.....	AS-28
Rotation Check.....	1-76	Cylinder Head	2-6
Crankshaft Gear, Front (Crankshaft Removed)	1-76	Assemble.....	2-26
Clean and Inspect for Reuse.....	1-77	Clean and Inspect for Reuse.....	2-16
Install.....	1-78	Disassemble.....	2-13
Remove.....	1-76	Finishing Steps.....	2-34
Crankshaft Gear, Rear (Crankshaft Removed)	1-79	Initial Check.....	2-10
General Information.....	1-79	Install.....	2-31
Crankshaft Gear, Rear (Crankshaft Removed)	1-80	Measure.....	2-30
General Information.....	1-80	Preparatory Steps.....	2-6
Crankshaft Seal, Front	DS-45	Pressure Test.....	2-23
Remove.....	DS-45	Remove.....	2-10
Crankshaft Seal, Front	AS-58	Test.....	2-6
Install.....	AS-58	Cylinder Head Gasket	DS-49
Crankshaft Seal, Front	1-80	Remove.....	DS-49
Clean and Inspect for Reuse.....	1-84	Cylinder Head Gasket	AS-24
Finishing Steps.....	1-89	Install.....	AS-27
General Information.....	1-80	Measure.....	AS-24
Install.....	1-86	Cylinder Head Gasket	2-45
Preparatory Steps.....	1-81	Clean and Inspect for Reuse.....	2-46
Remove.....	1-82	Finishing Steps.....	2-50
Crankshaft Seal, Rear	DS-10	General Information.....	2-45
Remove.....	DS-10	Install.....	2-49
Crankshaft Seal, Rear	AS-78	Measure.....	2-46
Install.....	AS-78	Preparatory Steps.....	2-45
Crankshaft Seal, Rear	1-90	Remove.....	2-46
Clean and Inspect for Reuse.....	1-94	Diesel Exhaust Fluid Usage - Abnormal.....	TS-92
Finishing Steps.....	1-100	Electrical Equipment - Overview	F-53
General Information.....	1-90	General Information.....	F-53
Install.....	1-95	ECM Cooling Plate, Fuel Cooled	DS-36
Preparatory Steps.....	1-90	Remove.....	DS-36
Remove.....	1-92	ECM Cooling Plate, Fuel Cooled	AS-36
Crankshaft Speed Indicator Ring	DS-45	Install.....	AS-36
Remove.....	DS-45	ECM Mounting Plate	DS-36
Crankshaft Speed Indicator Ring	AS-60	Remove.....	DS-36
Install.....	AS-60	ECM Mounting Plate	AS-36
Crankshaft Speed Indicator Ring	1-195	Install.....	AS-36

ECM Mounting Plate	1-200	Install.....	AS-89
Assemble.....	1-202	Flow Diagram, Air Intake System	F-45
Clean and Inspect for Reuse.....	1-201	General Information.....	F-45
Disassemble.....	1-201	Flow Diagram, Compressed Air System	F-52
Finishing Steps.....	1-202	Flow Diagram.....	F-52
General Information.....	1-200	Flow Diagram, Cooling System	F-33
Install.....	1-202	Flow Diagram.....	F-33
Preparatory Steps.....	1-200	Flow Diagram, Exhaust System	F-48
Remove.....	1-201	General Information.....	F-48
Engine Cranks Slowly — (Electric Starter).....	TS-60	Flow Diagram, Fuel System	F-11
Engine Dataplate	1-184	General Information.....	F-11
Clean and Inspect for Reuse.....	1-185	Flow Diagram, Lubricating Oil System	F-25
General Information.....	1-184	General Information.....	F-25
Install.....	1-185	Flywheel	DS-9
Remove.....	1-184	Remove.....	DS-9
Engine Decelerates Slowly.....	TS-43	Flywheel	AS-87
Engine Diagrams	E-6	Install.....	AS-87
Engine Views.....	E-6	Flywheel Housing	DS-14
Engine Identification	E-1	Remove.....	DS-14
Cummins® Engine Nomenclature.....	E-3	Flywheel Housing	AS-75
ECM Dataplate.....	E-4	Install.....	AS-75
Engine Dataplate.....	E-1	Fuel Connector (Head Mounted)	DS-28
Fuel Injection Pump Dataplate.....	E-4	Finishing Steps.....	DS-28
Engine Installation	0-9	Remove.....	DS-28
General Information.....	0-9	Fuel Connector (Head Mounted)	AS-48
Install.....	0-9	Finishing Steps.....	AS-48
Engine Mounting Bolts	0-23	Install.....	AS-48
Inspect for Reuse.....	0-23	Fuel Consumption Excessive.....	TS-65
Engine Noise Excessive.....	TS-44	Fuel Drain Lines	DS-29
Engine Noise Excessive — Combustion Knocks.....	TS-47	Remove.....	DS-29
Engine Noise Excessive — Connecting Rod.....	TS-48	Fuel Drain Lines	AS-43
Engine Noise Excessive - Drive Belt.....	TS-93	Install.....	AS-43
Engine Noise Excessive — Main Bearing.....	TS-50	Fuel Filter (Spin-On Type)	DS-33
Engine Noise Excessive — Piston.....	TS-51	Remove.....	DS-33
Engine Noise Excessive - Turbocharger.....	TS-52	Fuel Filter (Spin-On Type)	AS-40
Engine Painting	0-22	Install.....	AS-40
Preparatory Steps.....	0-22	Fuel Filter Head	DS-34
Engine Performance Troubleshooting Tree - ISB Engines Equipped with EGR (CM850 Electronic Control System)	TT-82	Remove.....	DS-34
Engine Performance Troubleshooting Tree - ISB, ISBe, and QSB engines without EGR (CM800 and CM850 Electronic Control System)	TT-1	Low Mount Fuel Filter.....	DS-34
Engine Performance Troubleshooting Tree for QSB5.9 Marine Engines with CM850 Electronic Control System	TT-49	High Mount Fuel Filter.....	DS-34
Engine Removal	0-2	Marine Applications.....	DS-35
General Information.....	0-2	Fuel Filter Head	AS-38
Remove.....	0-2	Install.....	AS-38
Engine Speed Surges in PTO or Cruise Control.....	TS-53	Low Mount Fuel Filter.....	AS-38
Engine Steam Cleaning	0-23	High Mount Fuel Filter.....	AS-39
Clean.....	0-23	Marine Applications.....	AS-39
Engine Storage - Long Term	0-19	Fuel in Coolant.....	TS-69
General Information.....	0-19	Fuel in the Lubricating Oil.....	TS-70
Engine Support Bracket, Front	DS-3	Fuel Lift Pump	DS-37
Remove.....	DS-3	Remove.....	DS-37
Engine Support Bracket, Front	AS-97	Fuel Lift Pump	AS-35
Install.....	AS-97	Install.....	AS-35
Engine Support Bracket, Rear	DS-3	Fuel Pump	DS-38
Remove.....	DS-3	Remove.....	DS-38
Engine Support Bracket, Rear	AS-97	Fuel Pump	AS-30
Install.....	AS-97	Install.....	AS-30
Engine Testing - Overview	F-54	Fuel Rail	DS-27
General Information.....	F-54	Remove.....	DS-27
Engine Will Not Crank — (Electric Starter).....	TS-58	Fuel Rail	AS-49
Engine Will Not Crank or Cranks Slowly (Air Starter).....	TS-62	Install.....	AS-49
Engine Will Not Shut Off.....	TS-64	Fuel Supply Lines	DS-31
Exhaust Manifold, Dry	DS-43	Remove.....	DS-31
Remove.....	DS-43	Fuel Supply Lines	AS-40
Exhaust Manifold, Dry	AS-84	Install.....	AS-40
Install.....	AS-84	Fuel System - Overview	F-6
Fan Hub, Belt Driven	DS-4	General Information.....	F-6
Remove.....	DS-4	Gear Cover, Front	DS-48
Fan Hub, Belt Driven	AS-96	Remove.....	DS-48
Install.....	AS-96	Gear Cover, Front	AS-55
Fan Spacer and Pulley	DS-4	Install.....	AS-55
Remove.....	DS-4	Gear Cover, Front	1-128
Fan Spacer and Pulley	AS-96	Clean and Inspect for Reuse.....	1-131
Install.....	AS-96	Finishing Steps.....	1-137
Mounting Bracket, Lubricating Oil and Fuel Filter	2-51	Install.....	1-133
Assemble.....	2-53	Preparatory Steps.....	1-128
Disassemble.....	2-52	Remove.....	1-130
Finishing Steps.....	2-54	Gear Housing, Front	DS-55
Inspect for Reuse.....	2-52	Remove.....	DS-55
Install.....	2-53	Gear Housing, Front	AS-14
Preparatory Steps.....	2-51	Install.....	AS-14
Remove.....	2-52	Gear Housing, Front	1-139
Flexplate	DS-9	Clean and Inspect for Reuse.....	1-142
Remove.....	DS-9	Finishing Steps.....	1-146
Flexplate	AS-89	Install.....	1-143
		Preparatory Steps.....	1-139
		Remove.....	1-141
		Gear Housing, Rear	DS-56

Index
Page X-4

Remove.....	DS-56	Piston and Connecting Rod Assembly	DS-57
Gear Housing, Rear	AS-13	Remove.....	DS-57
Install.....	AS-13	Piston and Connecting Rod Assembly	AS-7
Gear Housing, Rear	1-147	Install.....	AS-7
Clean and Inspect for Reuse.....	1-149	Piston and Connecting Rod Assembly	1-169
Finishing Steps.....	1-152	Assemble.....	1-175
Install.....	1-149	Clean and Inspect for Reuse.....	1-174
Preparatory Steps.....	1-147	Disassemble.....	1-173
Remove.....	1-148	Finishing Steps.....	1-183
General Cleaning Instructions	i-12	General Information.....	1-169
Abrasive Pads and Abrasive Paper.....	i-12	Install.....	1-178
Definition of Clean.....	i-12	Preparatory Steps.....	1-170
Fuel System.....	i-15	Remove.....	1-171
Gasket Surfaces.....	i-13	Piston Cooling Nozzle	DS-56
Plastic Bead Cleaning.....	i-14	Remove.....	DS-56
Solvent and Acid Cleaning.....	i-13	Piston Cooling Nozzle	AS-12
Steam Cleaning.....	i-14	Install.....	AS-12
General Repair Instructions	i-10	Piston Cooling Nozzle	1-156
General Information.....	i-10	Clean and Inspect for Reuse.....	1-158
Welding on a Vehicle with an Electronic Controlled Fuel System.....	i-11	Finishing Steps.....	1-159
General Safety Instructions	i-8	General Information.....	1-156
Important Safety Notice.....	i-8	Install.....	1-159
How to Use the Manual	i-2	Preparatory Steps.....	1-157
General Information.....	i-2	Remove.....	1-157
Illustrations	i-7	Piston Rings	1-160
General Information.....	i-7	Failure Analysis Inspection.....	1-160
Injector	DS-50	Push Rods or Tubes	DS-24
Finishing Steps.....	DS-50	Remove.....	DS-24
Preparatory Steps.....	DS-50	Push Rods or Tubes	AS-64
Remove.....	DS-50	Install.....	AS-64
Injector	AS-45	Push Rods or Tubes	4-2
Finishing Steps.....	AS-48	Clean.....	4-2
Install.....	AS-45	Inspect for Reuse.....	4-3
Remove.....	AS-45	Install.....	4-3
Injector Supply Lines (High Pressure)	DS-27	Preparatory Steps.....	4-2
Remove.....	DS-27	Remove.....	4-2
Injector Supply Lines (High Pressure)	AS-50	Rocker Lever	DS-24
Install.....	AS-50	Remove.....	DS-24
Injectors and Fuel Lines - Overview	F-14	Rocker Lever	AS-65
General Information.....	F-14	Install.....	AS-65
Intake Manifold Air Temperature Above Specification.....	TS-72	Rocker Lever	3-16
Intake Manifold Pressure (Boost) is Below Normal.....	TS-75	Assemble.....	3-20
Lubricating Oil Consumption Excessive.....	TS-77	Clean and Inspect for Reuse.....	3-18
Lubricating Oil Contaminated.....	TS-80	Disassemble.....	3-17
Lubricating Oil Cooler	DS-42	Finishing Steps.....	3-22
Remove.....	DS-42	Install.....	3-21
Lubricating Oil Cooler	AS-82	Preparatory Steps.....	3-16
Install.....	AS-82	Remove.....	3-17
Lubricating Oil Dipstick Tube	DS-4	Rocker Lever Cover	DS-20
Remove.....	DS-4	Remove.....	DS-20
Lubricating Oil Dipstick Tube	AS-96	Rocker Lever Cover	AS-66
Install.....	AS-96	Install.....	AS-66
Lubricating Oil Filter (Spin-On)	DS-41	Rocker Lever Cover	3-23
Remove.....	DS-41	Assemble.....	3-27
Lubricating Oil Filter (Spin-On)	AS-83	Clean and Inspect for Reuse.....	3-26
Install.....	AS-83	Disassemble.....	3-25
Lubricating Oil Lines	DS-2	Finishing Steps.....	3-30
Remove.....	DS-2	General Information.....	3-23
Lubricating Oil Lines	AS-99	Install.....	3-28
Install.....	AS-99	Preparatory Steps.....	3-23
Lubricating Oil Pan	DS-51	Remove.....	3-23
Remove.....	DS-51	Rocker Lever Housing	DS-23
Lubricating Oil Pan	AS-22	Remove.....	DS-23
Install.....	AS-22	Rocker Lever Housing	AS-65
Lubricating Oil Pressure High.....	TS-81	Install.....	AS-65
Lubricating Oil Pressure Low.....	TS-83	Rocker Lever Housing	3-31
Lubricating Oil Pump	DS-49	Clean.....	3-32
Remove.....	DS-49	Inspect for Reuse.....	3-32
Lubricating Oil Pump	AS-54	Install.....	3-32
Install.....	AS-54	Remove.....	3-31
Lubricating Oil Sludge in the Crankcase Excessive.....	TS-86	Sea Water Pump Pulley	DS-2
Lubricating Oil Suction Tube (Block-Mounted)	DS-52	Remove.....	DS-2
Remove.....	DS-52	Sea Water Pump Pulley	AS-98
Lubricating Oil Suction Tube (Block-Mounted)	AS-21	Install.....	AS-98
Install.....	AS-21	Service Tools	0-1
Lubricating Oil System - Overview	F-16	Engine Removal and Installation.....	0-1
General Information.....	F-16	Service Tools	1-1
Lubricating Oil Temperature Above Specification.....	TS-88	Cylinder Block.....	1-1
Lubricating or Transmission Oil in the Coolant.....	TS-89	Service Tools	2-1
Overhead Set	3-12	Cylinder Head.....	2-1
Adjust.....	3-13	Service Tools	3-1
Finishing Steps.....	3-16	Rocker Levers.....	3-1
General Information.....	3-12	Service Tools	4-1
Preparatory Steps.....	3-12	Cam Followers/Tappets.....	4-1
Piston	1-153	Starting Motor	DS-8
Clean and Inspect for Reuse.....	1-153	Remove.....	DS-8
Failure Analysis Inspection.....	1-154	Starting Motor	AS-89

Install.....	AS-89
Symbols	i-3
General Information.....	i-3
Tappet	DS-55
Remove.....	DS-55
Tappet	AS-16
Install.....	AS-16
Tappet	4-4
Clean and Inspect for Reuse.....	4-7
Finishing Steps.....	4-10
General Information.....	4-4
Install.....	4-8
Remove.....	4-4
Troubleshooting Overview	TS-3
Connecting Rod Bearing Noise.....	TS-3
Driveability - General Information.....	TS-3
Driveability/Low Power - Customer Complaint Form.....	TS-5
Driveability/Low Power/Excessive Fuel Consumption - Checklist.....	TS-8
Engine Noise Diagnostic Procedures - General Information.....	TS-3
Fuel Consumption - Customer Complaint Form.....	TS-10
Fuel Consumption - General Information.....	TS-9
Main Bearing Noise.....	TS-3
Oil Consumption.....	TS-11
Piston Noise.....	TS-3
Troubleshooting Procedures and Techniques	TS-1
General Information.....	TS-1
Troubleshooting Symptoms Charts	TS-2
General Information.....	TS-2
Turbocharger	DS-42
Remove.....	DS-42
Turbocharger	AS-85
Install.....	AS-85
Turbocharger Leaks Engine Oil or Fuel.....	TS-90
Turbocharger Oil Drain Line	DS-42
Remove.....	DS-42
Turbocharger Oil Drain Line	AS-86
Install.....	AS-86
Turbocharger Oil Supply Line	DS-41
Remove.....	DS-41
Turbocharger Oil Supply Line	AS-87
Install.....	AS-87
Valve Guide Seal, Cylinder Head	2-37
Clean and Inspect for Reuse.....	2-41
Finishing Steps.....	2-45
General Information.....	2-37
Install.....	2-42
Preparatory Steps.....	2-37
Remove.....	2-38
Vibration Damper, Rubber	DS-44
Remove.....	DS-44
Vibration Damper, Rubber	AS-61
Install.....	AS-61
Vibration Damper, Rubber	1-163
Clean and Inspect for Reuse.....	1-163
Finishing Steps.....	1-165
Install.....	1-165
Preparatory Steps.....	1-163
Remove.....	1-163
Vibration Damper, Viscous	DS-45
Remove.....	DS-45
Vibration Damper, Viscous	AS-61
Install.....	AS-61
Vibration Damper, Viscous	1-166
Clean and Inspect for Reuse.....	1-166
Finishing Steps.....	1-168
Install.....	1-168
Preparatory Steps.....	1-166
Remove.....	1-166
Vibration Excessive	TT-141
Water Inlet Connection	DS-44
Remove.....	DS-44
Water Inlet Connection	AS-62
Install.....	AS-62
Water Pump	DS-44
Remove.....	DS-44
Water Pump	AS-63
Install.....	AS-63

Cummins Inc.

Box 3005
Columbus, Indiana, U.S.A., 47202

Registered Office

Cummins Ltd.

49 - 51 Gresham Road,
Staines,
Middlesex TW18 2BD,
England
Registration 573951 England

Copyright® 2014
Cummins Inc.