

GROUP 2 SPECIFICATION

1. MAJOR COMPONENT

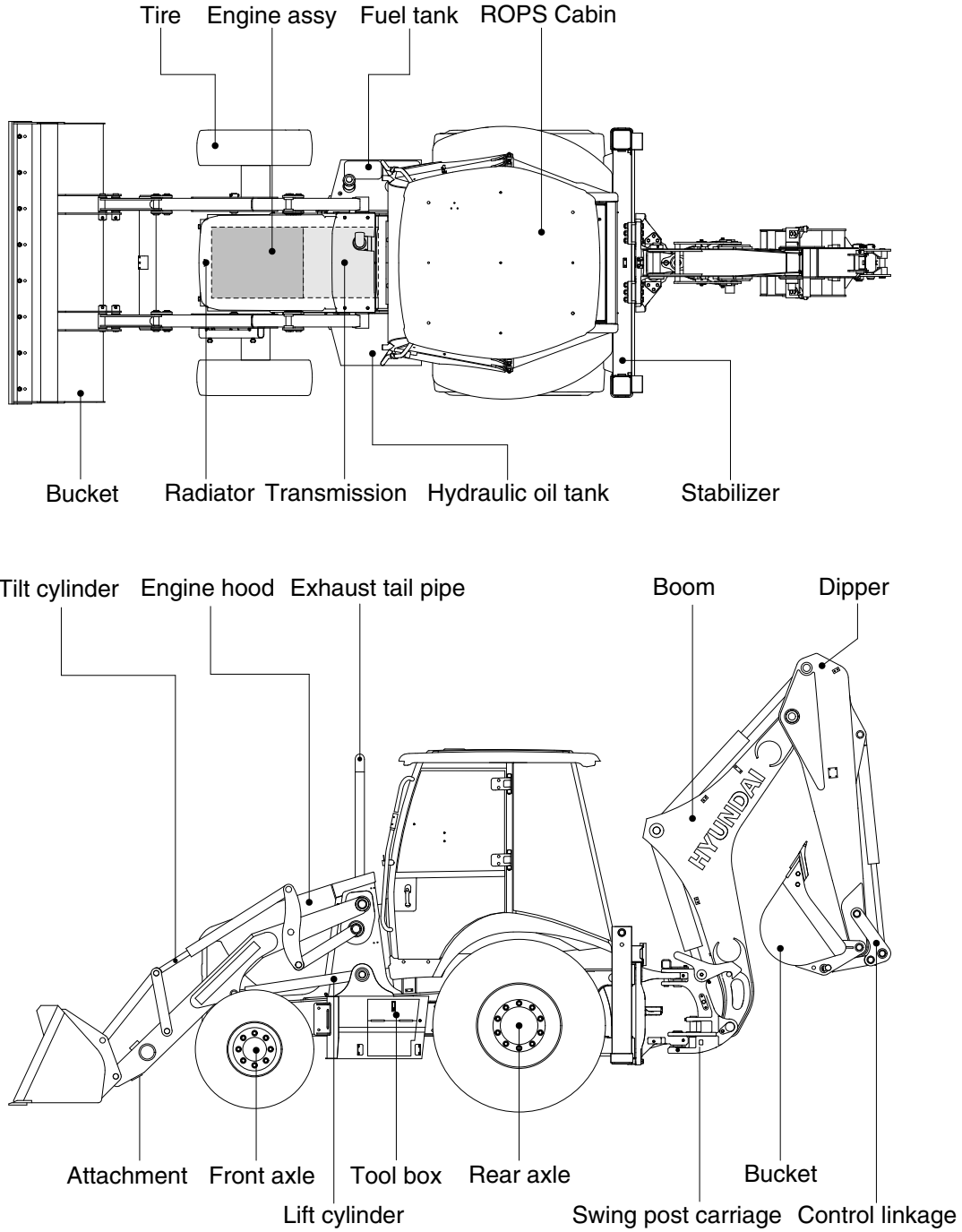

H930ST2SP01

2. SPECIFICATIONS

1) H930ST/H940ST

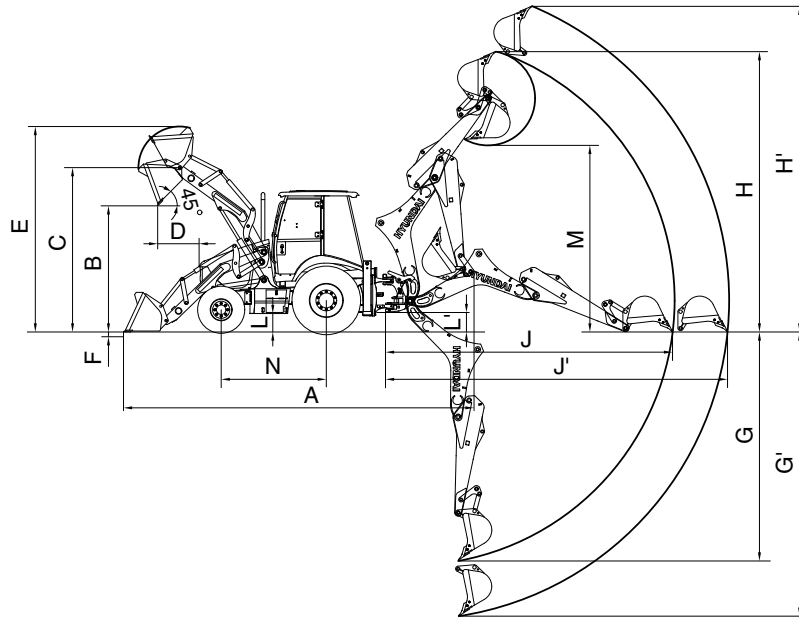

H940S2SP02

Description		Unit	Specification	
			H940ST	H930ST
Operating weight	Standard dipper and GP bucket	kg (lb)	8250 (18190)	8200 (18080)
	Extendible dipper and MP bucket	kg (lb)	8750 (19290)	8700 (19180)
Transport length	GP bucket		5860 (19' 3")	5860 (19' 3")
	MP bucket		5910 (19' 5")	5910 (19' 5")
Transport height	Standard dipper		4010 (13' 2")	3835 (12' 7")
	Extendible dipper		4010 (13' 2")	3835 (12' 7")
Transport width	GP bucket		2450 (8' 1")	2450 (8' 1")
	MP bucket		2450 (8' 1")	2450 (8' 1")
Loader data	Overall length	A	7310 (24' 0")	7310 (24' 0")
	Dump clearance	B	2690 (8' 10")	2690 (8' 10")
	Hinge pin height	C	3485 (11' 5")	3485 (11' 5")
	Dump reach	D	785 (2' 7")	785 (2' 7")
	Max loading height	E	4345 (14' 3")	4345 (14' 3")
	Depth of bucket down	F	61 (2.4")	61 (2.4")
	Wheel base	N	2200 (7' 3")	2200 (7' 3")
Backhoe data	Max digging depth (STD)	G	4525 (14' 10")	4255 (13' 11")
	Max digging depth (EXT)	G'	5650 (18' 6")	5380 (17' 8")
	Max digging height (STD)	H	5865 (19' 3")	5700 (18' 8")
	Max digging height (EXT)	H'	6535 (21' 5")	6370 (20' 11")
	Max digging reach (STD)	J	5980 (19' 7")	5820 (19' 1")
	Max digging reach (EXT)	J'	6990 (22' 11")	6830 (22' 5")
	Minimum ground clearance	L	515 (1' 5")	515 (1' 5")
	Height of outrigger	L'	340 (1' 1")	340 (1' 1")
	Max dumping height (STD)	M	3935 (12' 11")	3775 (12' 5")
	Max dumping height (EXT)	M'	4610 (15' 1")	4450 (14' 7")

3. SPECIFICATION FOR MAJOR COMPONENTS

1) ENGINE

Item	Specification	
	H940ST	H930ST
Manufacture	PERKINS	
Model	1104C-44T	
Type	4-stroke, turbocharged	4-stroke, turbocharged
Non-road emission standards	Certified to EPA Tier 3 / EU stage III-A & UN R96	
Piston displacement	4.4 l (1.2 U.S.gal)	
Fuel	Diesel	
Rated horse power (Gross)	100 hp (74.5 kW) at 2200 rpm	94 hp (70.1 kW) at 2200 rpm
Maximum torque at 1350 rpm	42 kgf · m (301 lbf · ft)	40 kgf · m (291 lbf · ft)
Alternator	100 amp	
Battery	12V	

2) MAIN PUMP

Item		Specification	
		H940ST	H930ST
Type		Fixed displacement double gear pump	
Capacity	Steering	31.4 cc/rev	31.4 cc/rev
	Attachment	35.4 cc/rev	31.4 cc/rev
Maximum operating pressure		250 kgf/cm ² (3560 psi)	
Rated oil quantity	Steering	68 l /min (18.0 U.S.gpm)	68 l /min (18.0 U.S.gpm)
	Attachment	77 l /min (20.3 U.S.gpm)	68 l /min (20.3 U.S.gpm)
Rated speed		2230 rpm	

3) MAIN CONTROL VALVE FOR LOADER

Item		Specification
Type		2 spool (option : 3 spool)
Operating method		Hydraulic pilot control
Main relief valve pressure		250 kgf/cm ² (3560 psi)
Unloading relief valve pressure		220 kgf/cm ² (3130 psi)
Overload relief valve pressure	Bucket out	175 kgf/cm ² (2490 psi)
	Bucket in	300 kgf/cm ² (4270 psi)

4) MAIN CONTROL VALVE FOR BACKHOE

Item	Unit	Specification	
Type	-	6 spool (option : 7 spool)	
Operating method	-	Hydraulic pilot control	
Main relief valve pressure	kgf/cm ² (psi)	250 (3560)	
Overload relief valve pressure	Boom up	kgf/cm ² (psi)	280 (3980)
	Boom down	kgf/cm ² (psi)	280 (3980)
	Swing LH, RH	kgf/cm ² (psi)	250 (3560)
	Bucket in	kgf/cm ² (psi)	280 (3980)
	Bucket out	kgf/cm ² (psi)	280 (3980)
	Dipper in	kgf/cm ² (psi)	280 (3980)
	Dipper out	kgf/cm ² (psi)	280 (3980)

5) STEERING UNIT

Item	Unit	Specification	
Type	-	Dynamic load sensing, non load reaction	
		Emergency 4WD	4WD
Displacement	cc/rev	160 + 60	160
Relief valve pressure	kgf/cm ² (psi)	248 (3530)	210 (2990)
Overload relief valve pressure	kgf/cm ² (psi)	303 (4310)	265 (3770)

6) PILOT SUPPLY UNIT

Item	Unit	Specification
Reducing & relief valve pressure	kgf/cm ² (psi)	30 (430)
Safety solenoid valve	Voltage	DC 12V
	Ampere	1.8 A

7) ACCUMULATOR

Item	Unit	Specification	
		Ride control	Pilot supply
Type	-	Nitrogen	
Capacity	ℓ	1.5	0.35
Precharge pressure	kgf/cm ² (psi)	30 (430)	15 (215)
Max working pressure	kgf/cm ² (psi)	350 (4980)	170 (2420)

8) REMOTE CONTROL VALVE

Item		Unit	Specification		
			For backhoe	For stabilizer	For loader
Type		-	Pressure reducing type		
Operating	Minimum	kgf/cm ² (psi)	4 (57)	5.5 (78)	5 (70)
	Maximum	kgf/cm ² (psi)	26 (370)	26 (370)	16.5 (235)
Single operation angle		degree	19	23.5	16.5

9) LINE FILTER

Item	Unit	Specification
Filtration rating	μm	10
Max working pressure	kgf/cm ² (psi)	280 (3980)
Bypass cracking pressure	kgf/cm ² (psi)	7 (100)

10) DOUBLE PILOT CHECK VALVE FOR STABILIZER

Item	Unit	Specification
Max working pressure	kgf/cm ² (psi)	350 (4980)
Cracking pressure	kgf/cm ² (psi)	4.5 (64)
Pilot ratio	-	1 : 5.5

11) TIRES

Item		Unit	H940ST	H930ST
Front	standard	-	16/70-20	16/70-20
	option	-	12.5/80-20	12.5/80-20
Rear	standard	-	16.9-28	18.4-26
	option	-	18.4-26	16.9-28

12) POWER TRAIN

Item		Specification			
Transmission		4-Speed helical-cut gears, full powershift with hydraulic control standard, electric clutch cutoff on loader lever			
Maximum travel speed with standard tire					
H930ST	Gear	1st	2nd	3rd	4th
	Forward (km/hr)	5.7	10.4	20.8	36.0
	Reverse (km/hr)	7.2	13.0	20.5 (opt)	N/A
H940ST	Gear	1st	2nd	3rd	4th
	Forward (km/hr)	5.6	10.2	20.4	35.5
	Reverse (km/hr)	7.1	12.8	20.1 (opt)	N/A
Torque converter (ratio)		1 : 2.53			
Differential lock		Front : Conventional Rear : Hydraulic lock (push-button activation)			
Steering		Hydrostatic power and emergency steering			
Brake	Service	Hydraulic wet disc, mounted inboard, self-adjusting and self-equalizing			
	Parking	Spring applied, hydraulically releases, wet, multi disc independent of service brakes with electric switch control			

13) BUCKET

Item		Capacity (liters)	Width (mm)	Weight (kg)
Loader	GP	1100	2450	435
	MP	1100	2450	755
Backhoe	H930ST	170	630	131
	H940ST	200	610	156

14) RECOMMENDED LUBRICANTS

Use only oils listed below or equivalent.

Do not mix different brand oil.

Service point	Kind of fluid	Capacity ℓ (U.S. gal)	Ambient temperature °C (°F)									
			-50 (-58)	-30 (-22)	-20 (-4)	-10 (14)	0 (32)	10 (50)	20 (68)	30 (86)	40 (104)	
Engine oil pan	Engine oil	8 (2.1)	★ ¹ SAE 5W-40					SAE 30				
			SAE 10W				SAE 10W-30					
			SAE 15W-40									
			SAE 10W-30									
			SAE 15W-40									
Transmission	Engine oil	18 (4.6)	SAE 10W-30									
			SAE 15W-40									
Axle	UTTO	Front (4WD): 8 (2.1)	★Refer to below list									
		Rear : 16 (4.2)										
Hydraulic tank	Hydraulic oil	Tank: 60 (15.9)	★ ¹ ISO VG 15									
		System: 93 (24.6)	ISO VG 46				ISO VG 68					
Fuel tank	Diesel fuel	127 (33.5)	★ ¹ ASTM D975 NO.1					ASTM D975 NO.2				
Fitting (grease nipple)	Grease	As required	★ ¹ NLGI NO.1					NLGI NO.2				
Radiator (reservoir tank)	Mixture of antifreeze and soft water★ ²	20 (5.3)	Ethylene glycol base permanent type (50 : 50)									
			★ ¹ Ethylene glycol base permanent type (60 : 40)									

· SAE : Society of Automotive Engineers

· API : American Petroleum Institute

· ISO : International Organization for Standardization

· NLGI : National Lubricating Grease Institute

· ASTM : American Society of Testing and Material

· UTTO : Universal Tractor Transmission Oil

★ Recommended oil list

- BP TERRAC SUPER TRANSMISSION 10W-30

- CASTROL AGRI TRANS PLUS 10W-30

- MOBILFLUID 426

- SHELL DONAX TD 10W-30

- TOTAL DYNATRANS MPV

★¹ Cold region : Russia, CIS, Mongolia

★² Soft water

City water or distilled water