

GROUP 2 ELECTRICAL CIRCUIT

1. ELECTRICAL CIRCUIT (1/3, MECHANICAL)

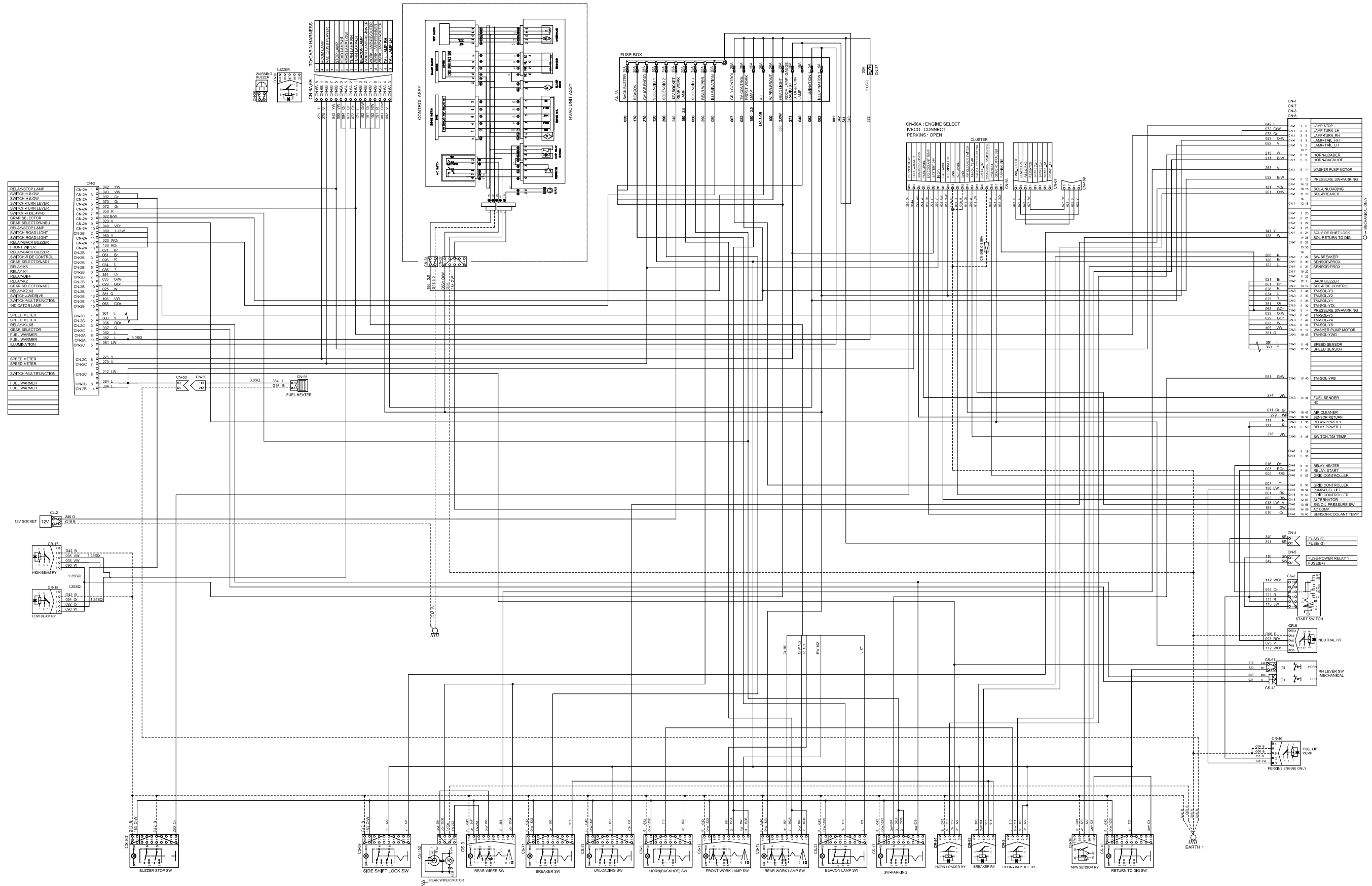

2. ELECTRICAL CIRCUIT (2/3, MECHANICAL & PILOT)

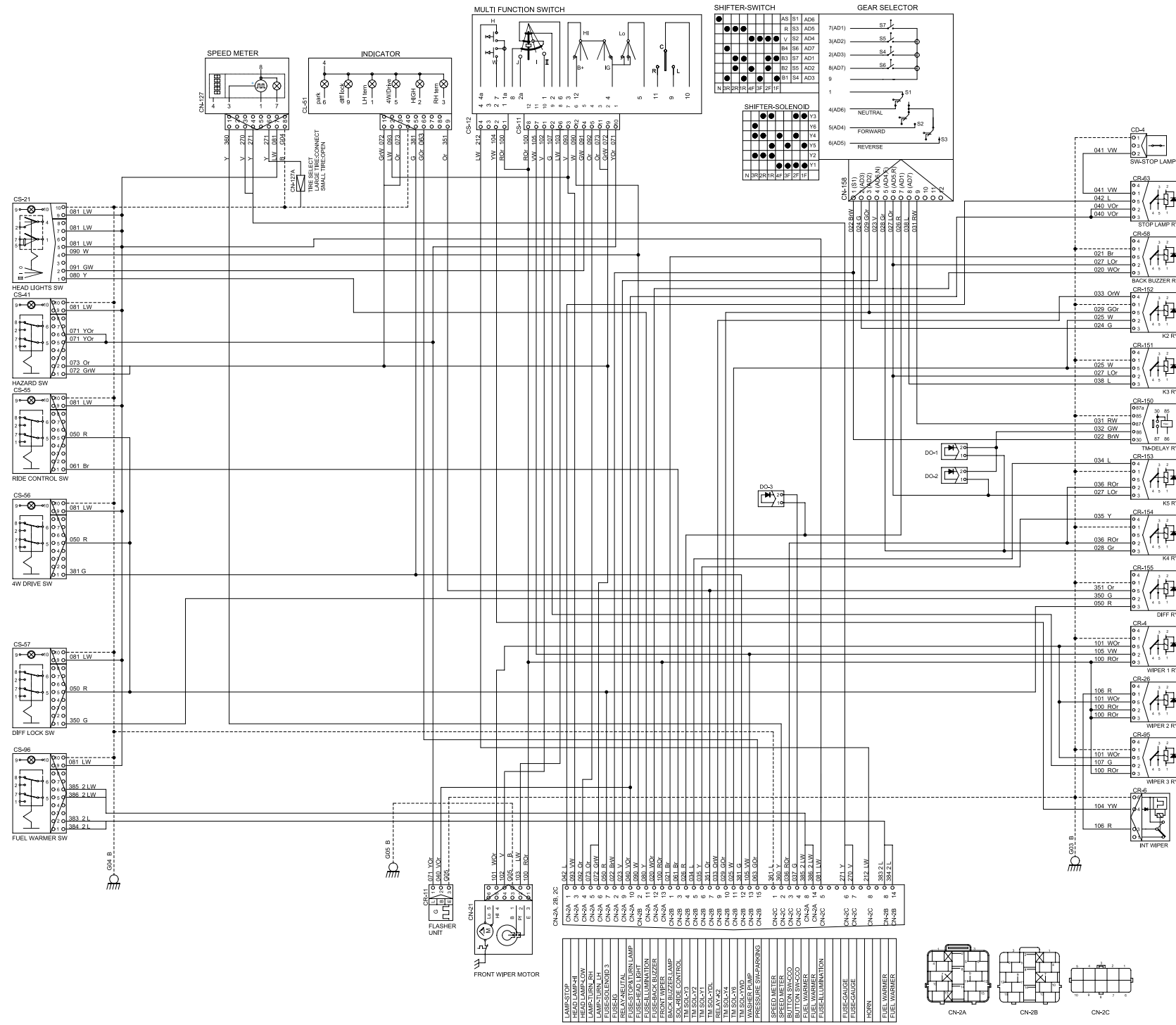

CAB TYPE

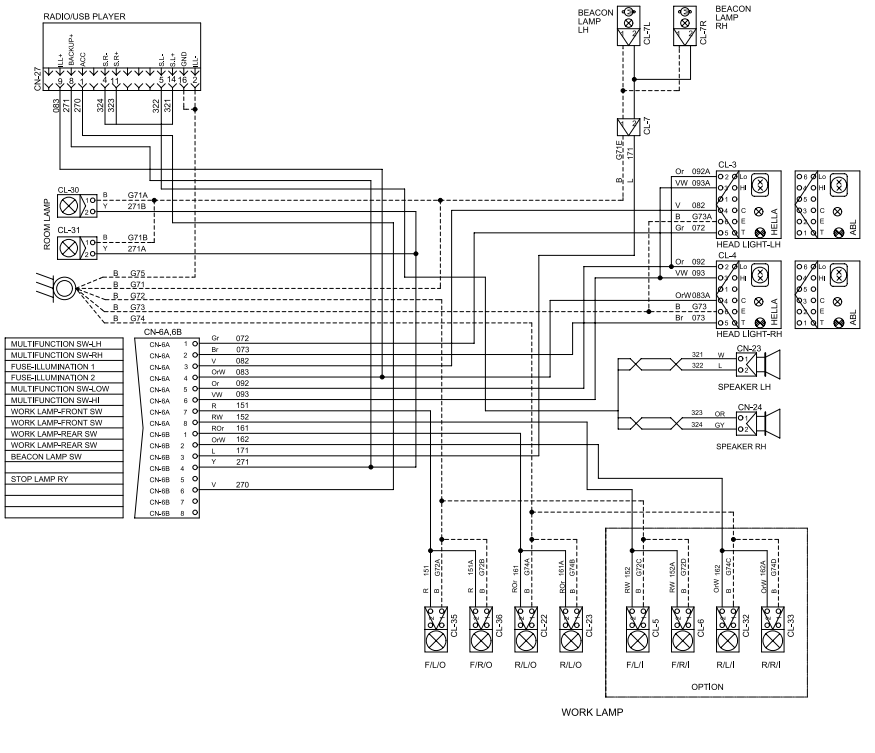

CANOPY TYPE

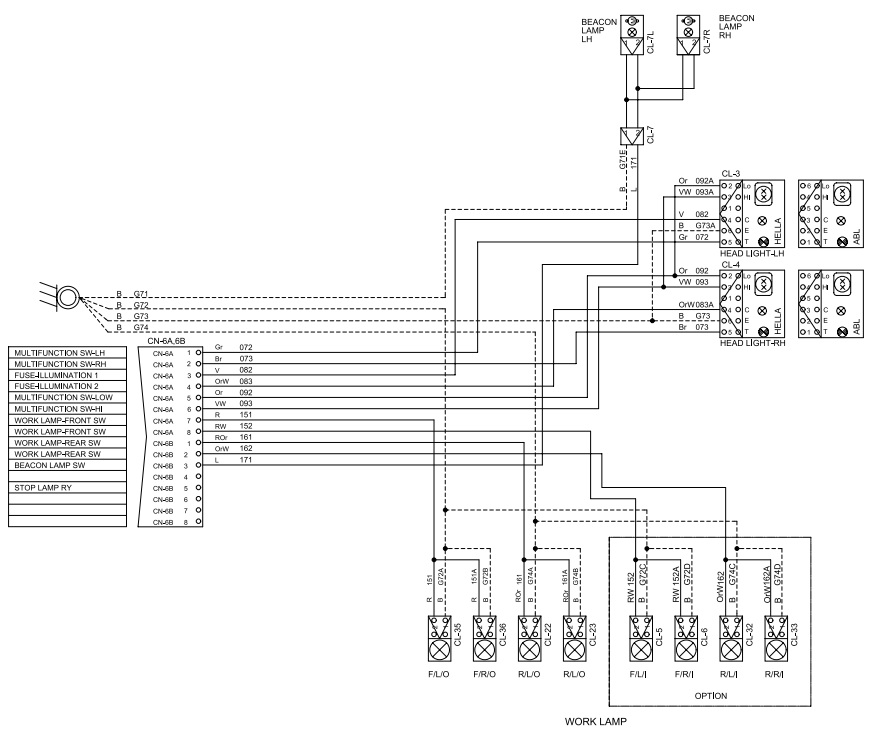

3. ELECTRICAL CIRCUIT (3/3, MECHANICAL)

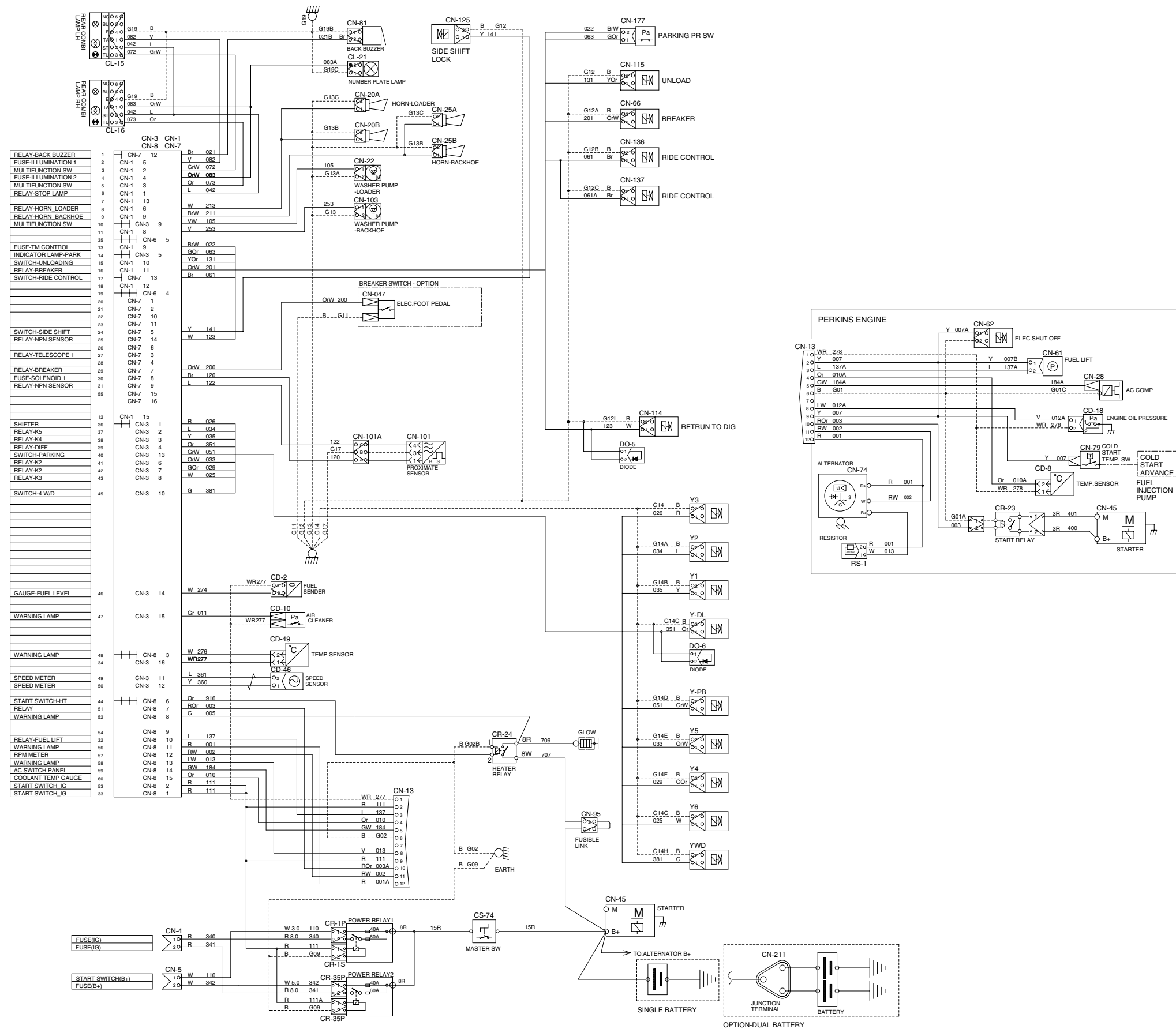

ELECTRICAL CIRCUIT (3/3, PILOT)

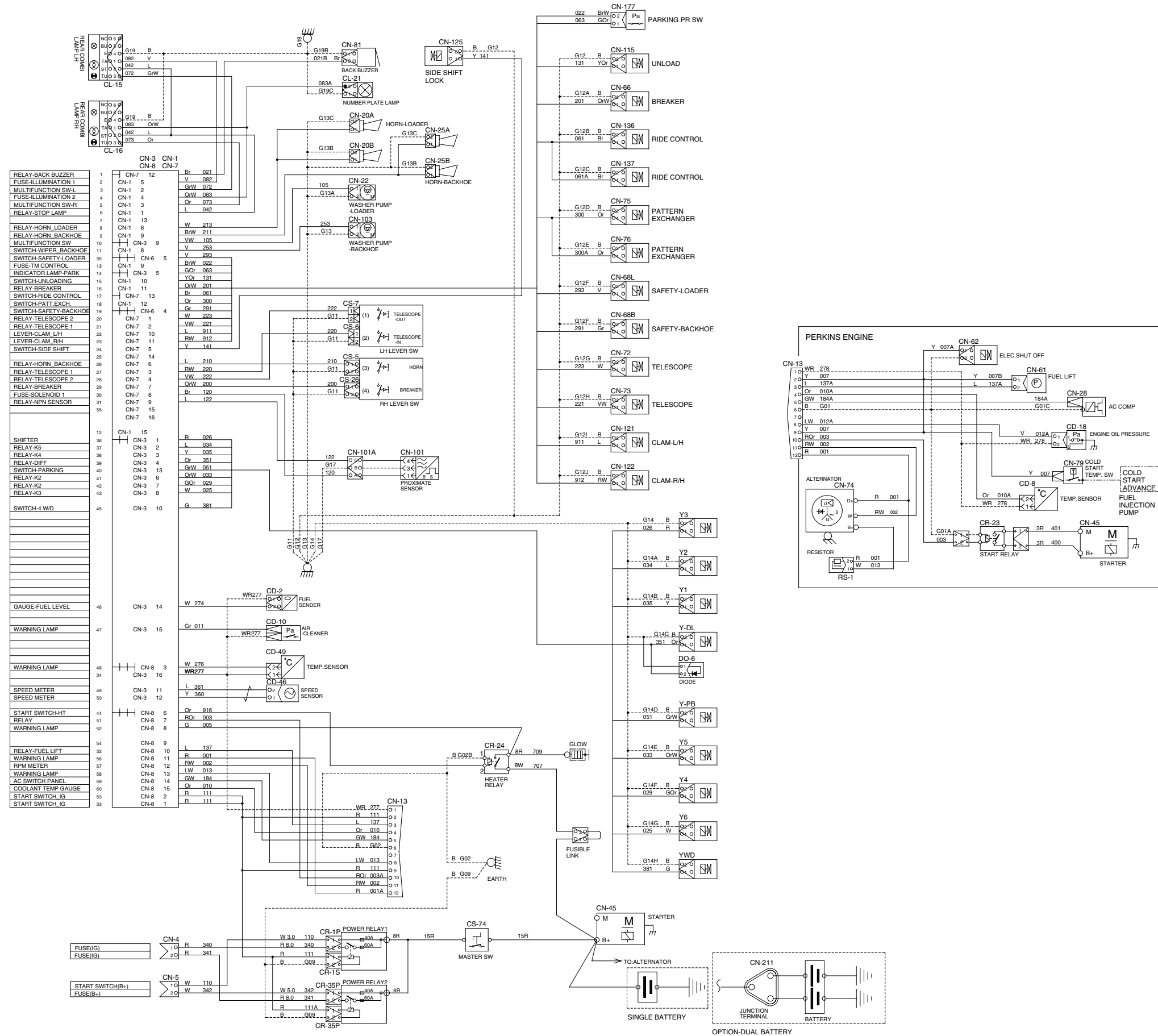



1. ILLUMINATION CIRCUIT

1) OPERATING FLOW

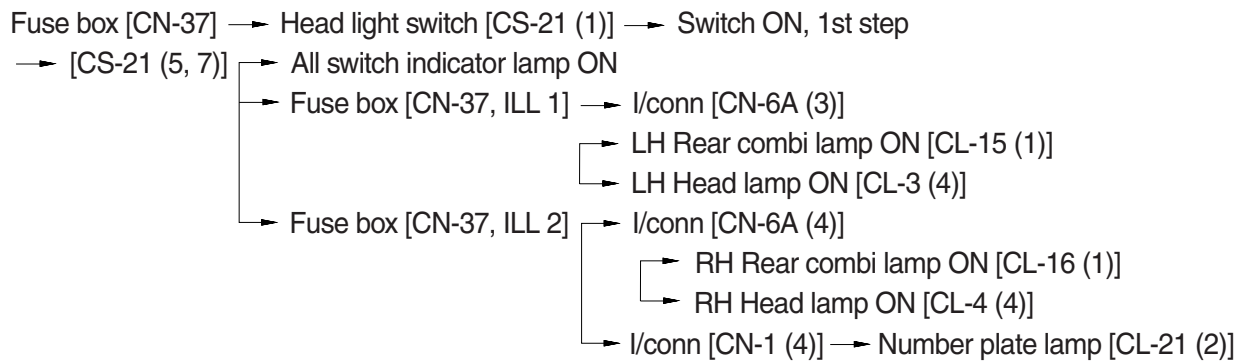

2) CHECK POINT

Engine	Key switch	Check point	Voltage
OFF	ON	① - GND (switch input) ② - GND (switch output) ③ - GND (to light)	12V

※ GND : Ground

ILLUMINATION CIRCUIT

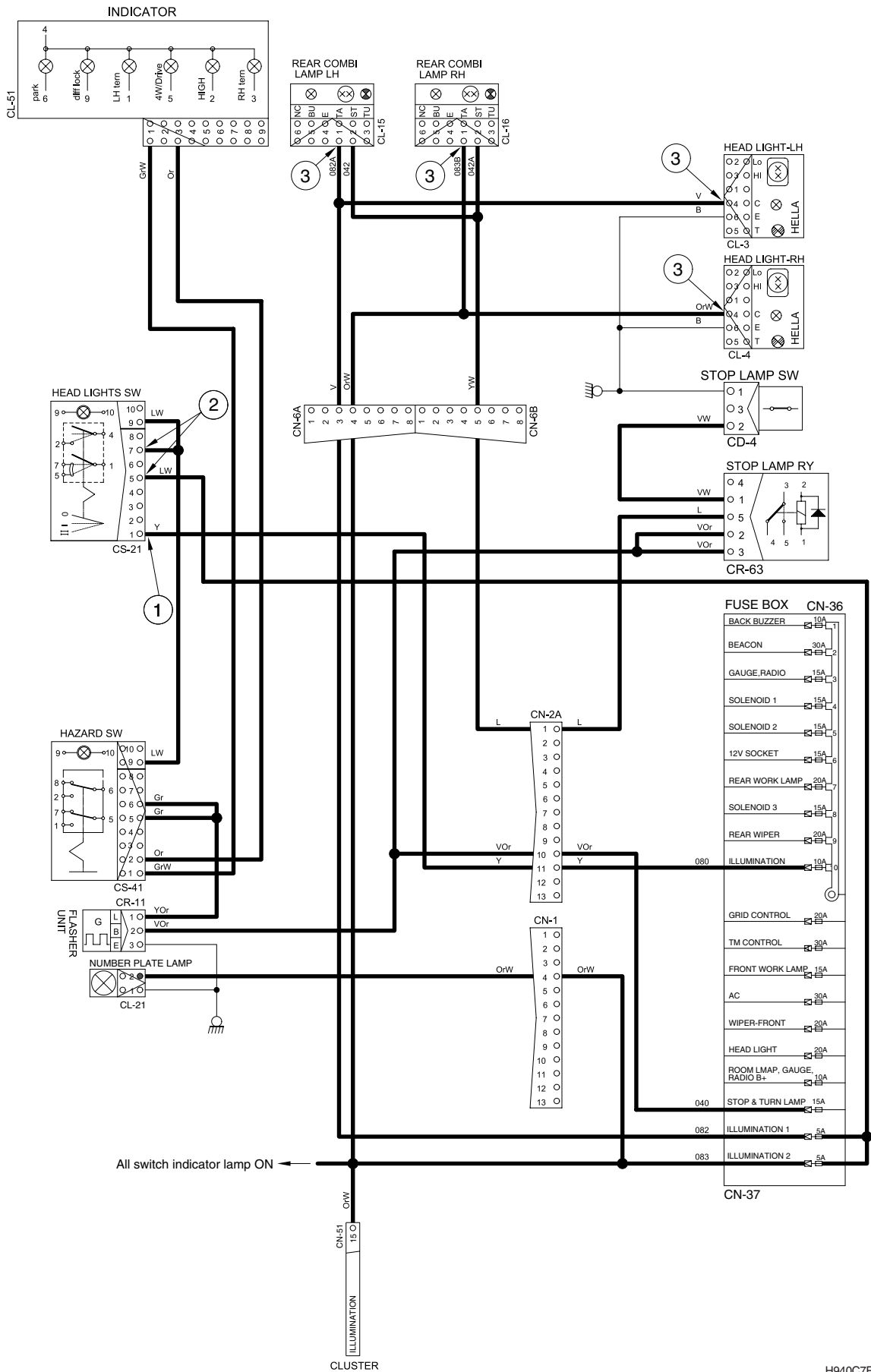

H940C7EL04

2. HEAD LIGHT CIRCUIT

1) OPERATING FLOW

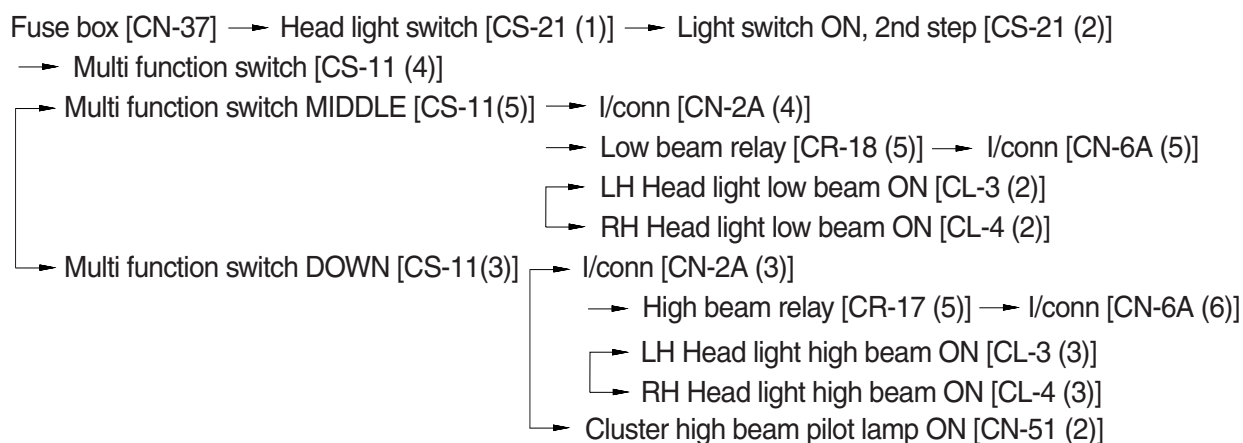

2) CHECK POINT

Engine	Key switch	Check point	Voltage
OFF	ON	① - GND (switch input) ② - GND (switch output) ③ - GND (multi function input) ④ - GND (multi function output, low beam) ⑤ - GND (multi function output, high beam)	12V

※ GND : Ground

HEAD LIGHT CIRCUIT

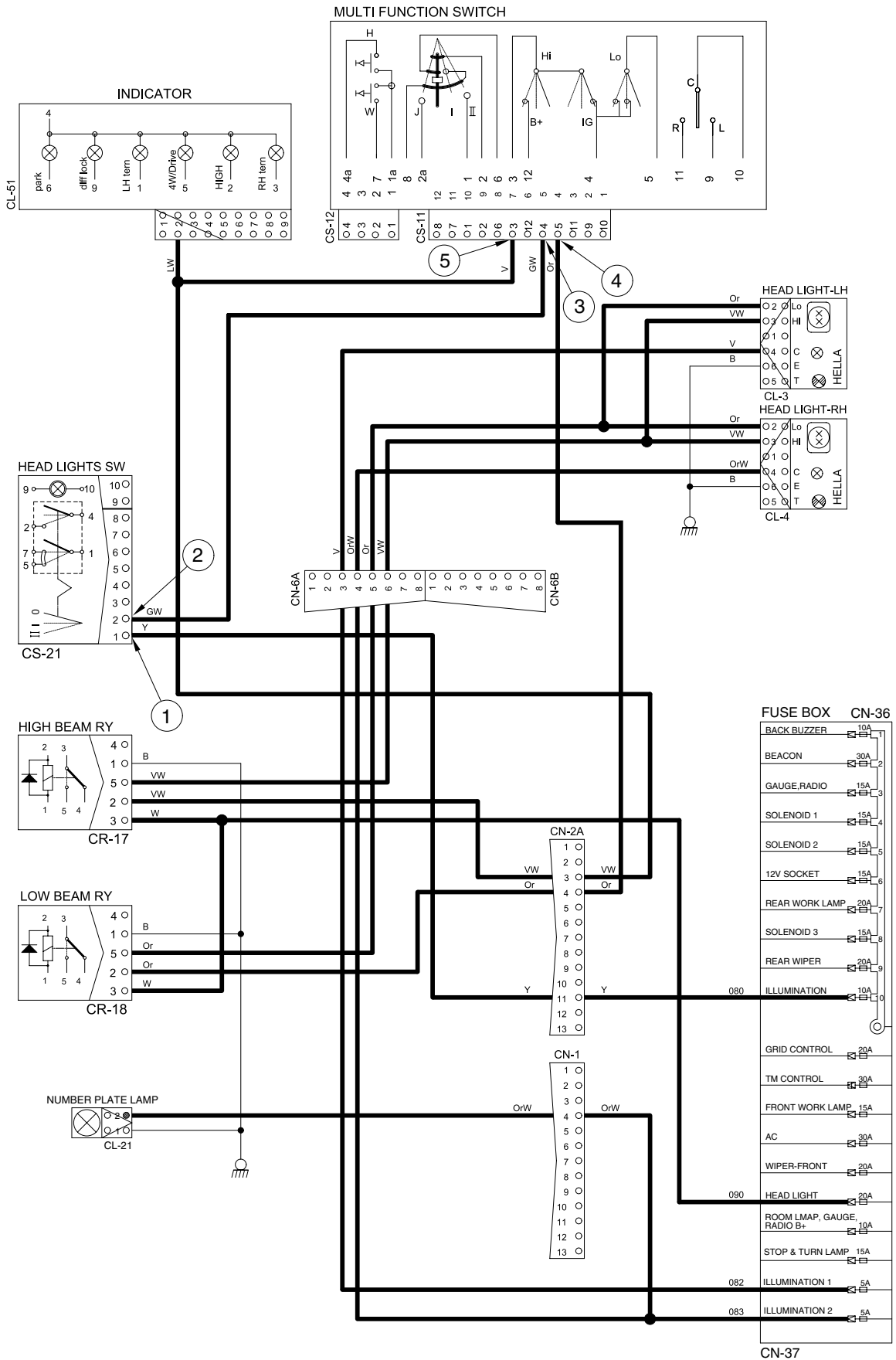

H940C7EL05

3. WORK LIGHT SWITCH

1) OPERATING FLOW

(1) Work lamp switch ON (1st step)

- Front work lamp switch [CS-12 (1) → (5)] → I/conn [CN-6A (7)]
- LH Front work lamp, outside [CL-35 (2)]
 - RH Front work lamp, outside [CL-36 (2)]
- Rear work lamp switch [CS-13 (1) → (5)] → I/conn [CN-6B (1)]
- LH Rear work lamp, outside [CL-22 (2)]
 - RH Rear work lamp, outside [CL-23 (2)]

(2) Work lamp switch ON (2nd step)

- Front work lamp switch [CS-12 (4) → (2)] → I/conn [CN-6A (8)]
- LH Front work lamp, inside [CL-5 (2)]
 - RH Front work lamp, inside [CL-6 (2)]
- Rear work lamp switch [CS-13 (4) → (2)] → I/conn [CN-6B (2)]
- LH Rear work lamp, inside [CL-32 (2)]
 - RH Rear work lamp, inside [CL-33 (2)]

2) CHECK POINT

Engine	Key switch	Check point	Voltage
OFF	ON	① - GND (work lamp power input) ② - GND (work lamp power output) ③ - GND (front work lamp) ④ - GND (rear work lamp)	12V

※ GND : Ground

WORK LIGHT SWITCH

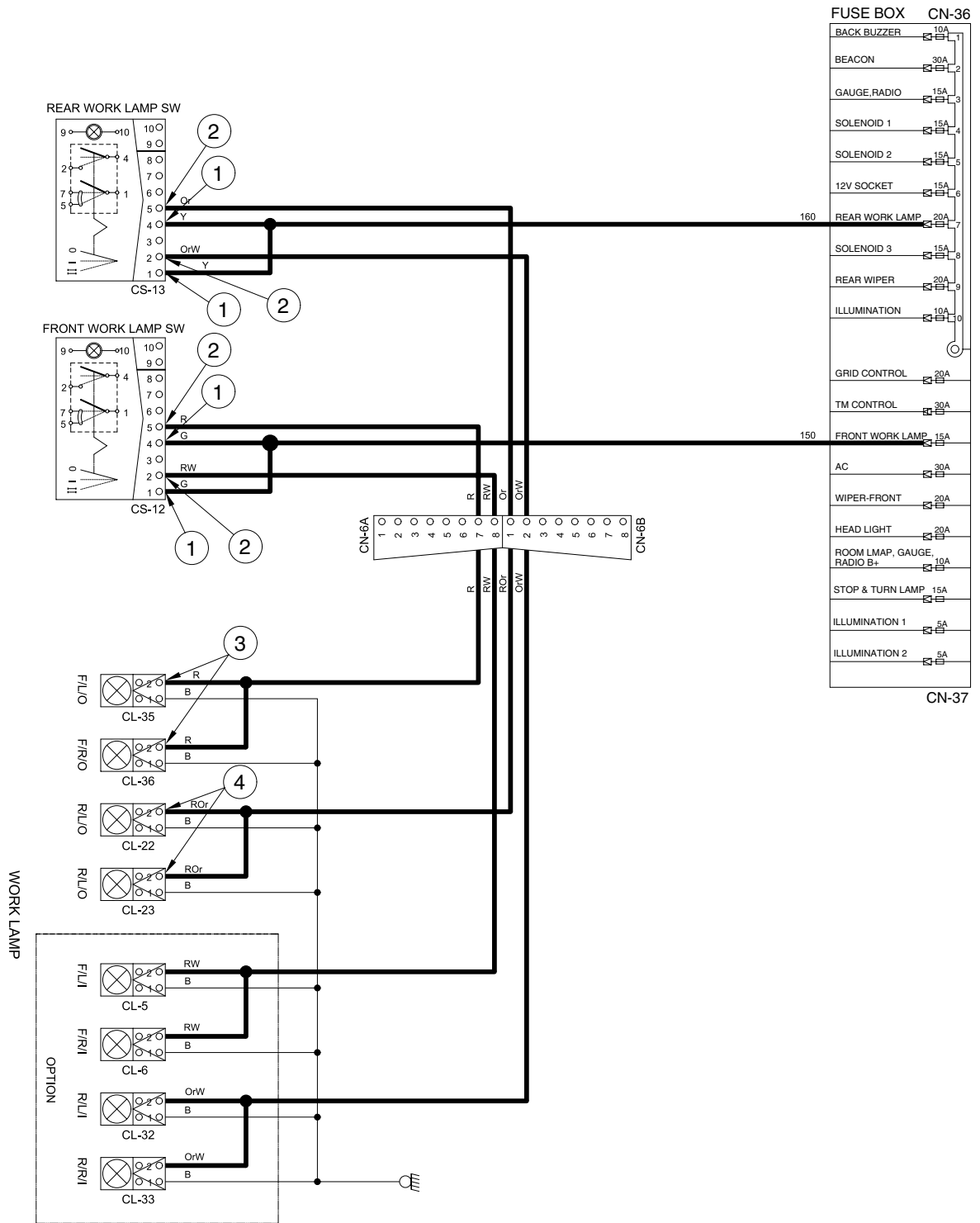

H940C7EL06

4. STARTING CIRCUIT

1) OPERATING FLOW

Battery(+) terminal → Master switch [(CS-74)]

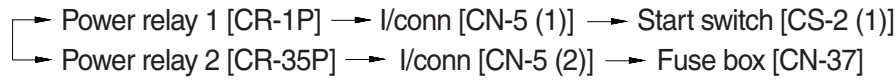

※ The gear selector lever is neutral position. It is necessary condition before the starting.

The gear selector has an output signal which is activated whenever the shift lever is in the neutral position. This signal can be used to control a relay and prevent engine from starting whenever the shift lever is not in the neutral position.

(1) When start key switch is in ON position

Start switch ON → Start switch [CS-2 (2, 3)] → I/conn [CN-8 (1, 2)]

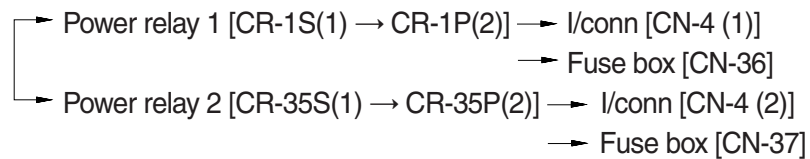

(2) When start key switch is in START position

Start switch START [CS-2 (6)] → Start safety relay [CR-5 (87a)→(87)] → I/conn [CN-8 (7)] →
 I/conn [CN-13 (10)] → Start relay [CR-23] →
 Starter (terminal B⁺ and M connector of start motor)

2) CHECK POINT

Engine	Key switch	Check point	Voltage
Running	ON	① - GND (battery B ⁺) ② - GND (Power relay) ③ - GND (start key B terminal) ④ - GND (start key BR, ACC terminal) ⑤ - GND (start key C terminal) ⑥ - GND (start safety relay output)	12 V

※ GND : Ground

STARTING SWITCH

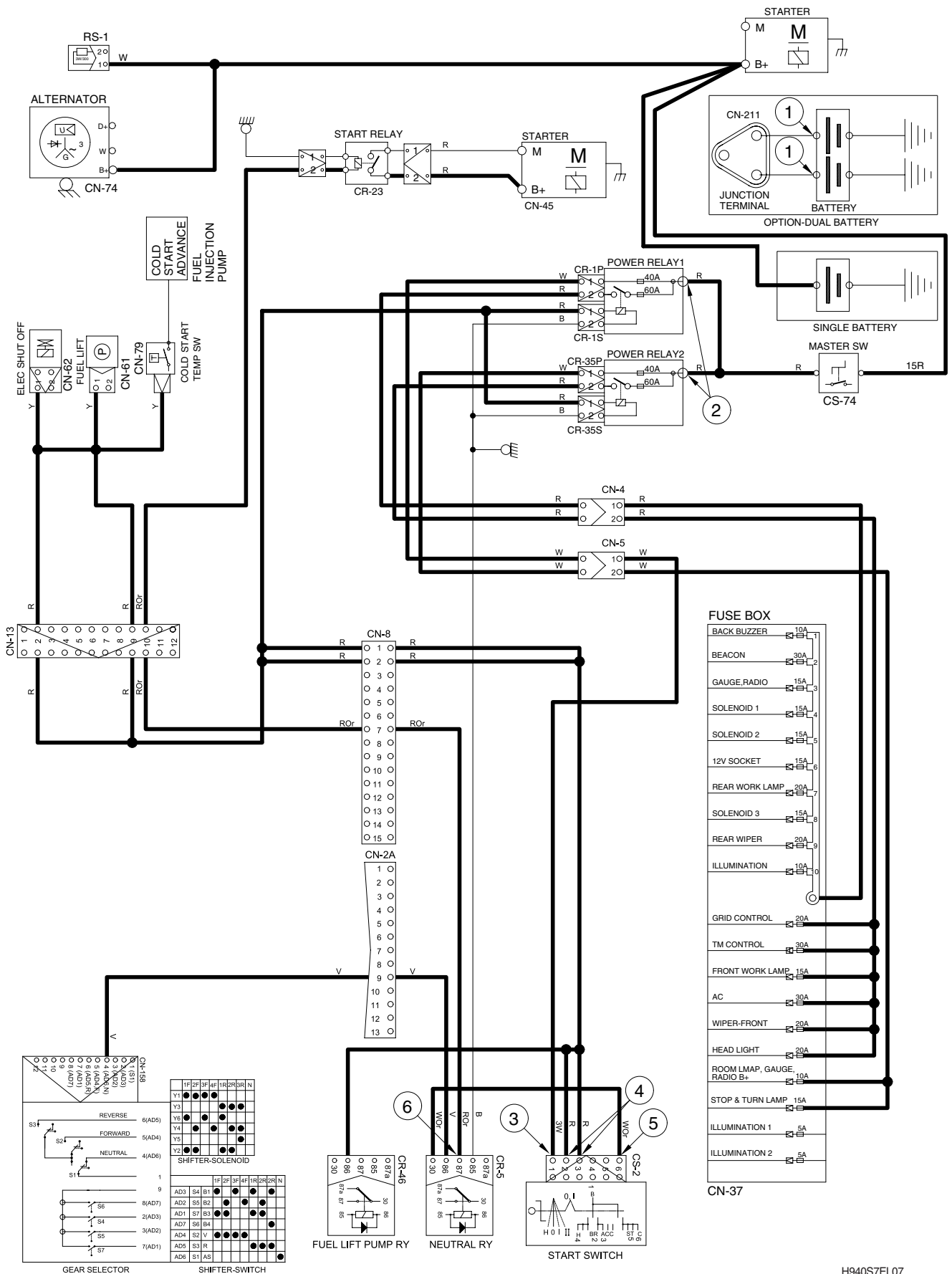

H940S7EL07

5. CHARGING CIRCUIT

When the starter is activated and the engine is started, the operator releases the key switch to the ON position.

Charging current generated by operating alternator flows into the battery.

The current also flows from alternator to each electrical component and controller through the fuse box.

1) OPERATING FLOW

(1) Warning flow

Alternator [CN-74 (D⁺)] → I/conn [CN-13 (12)] → I/conn [CN-8 (11)] →
Charge warning lamp ON [CL-56 (6)]

(2) Charging flow

Alternator → Starter (B⁺) → Battery(+) terminal → Charging

2) CHECK POINT

Engine	Key switch	Check point	Voltage
OFF	ON	① - GND (battery) ② - GND (alternator B ⁺) ③ - GND (alternator D ⁺)	12V

※ GND : Ground

※ MCU : Machine control unit

CHARGING CIRCUIT

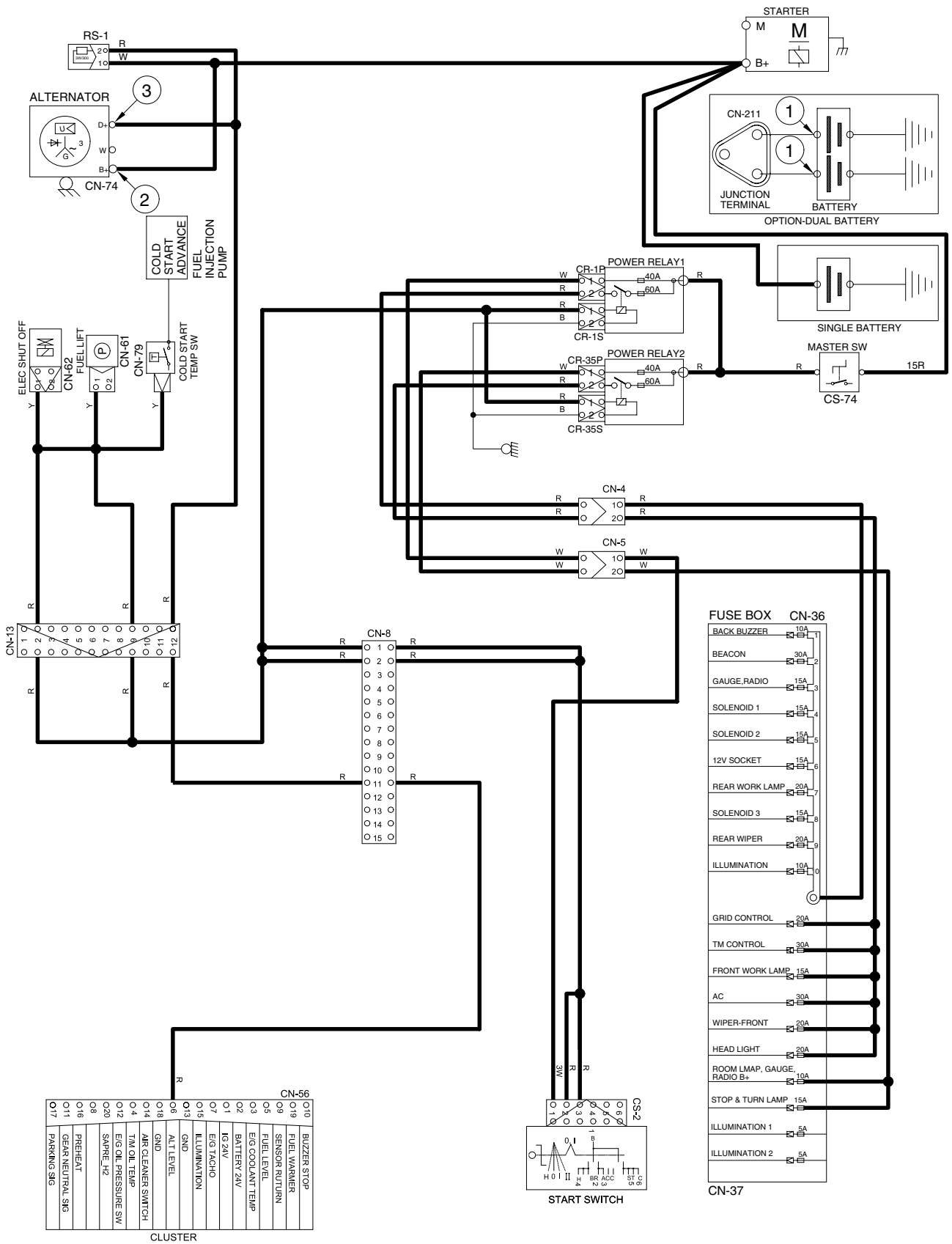

H940SEL08

6. PREHEATING CIRCUIT

Combustion chamber glow plugs are used in order to give satisfactory starting of low ambient temperatures.

1) OPERATING FLOW

Start switch ON → Start switch [CS-2 (4)] → I/conn [CN-8 (9)]

→ Heater relay [CR-24 (2)] → Pre-heater ON

→ Heater relay [CR-24 (1)] → I/conn [CN-8 (8)] → Warning lamp ON [CN-56 (16)]

2) CHECK POINT

Engine	Key switch	Check point	Voltage
STOP	HEAT	① - GND (battery B ⁺) ② - GND (fuse box) ③ - GND (heater relay)	12V

※ GND : Ground

PREHEATING CIRCUIT

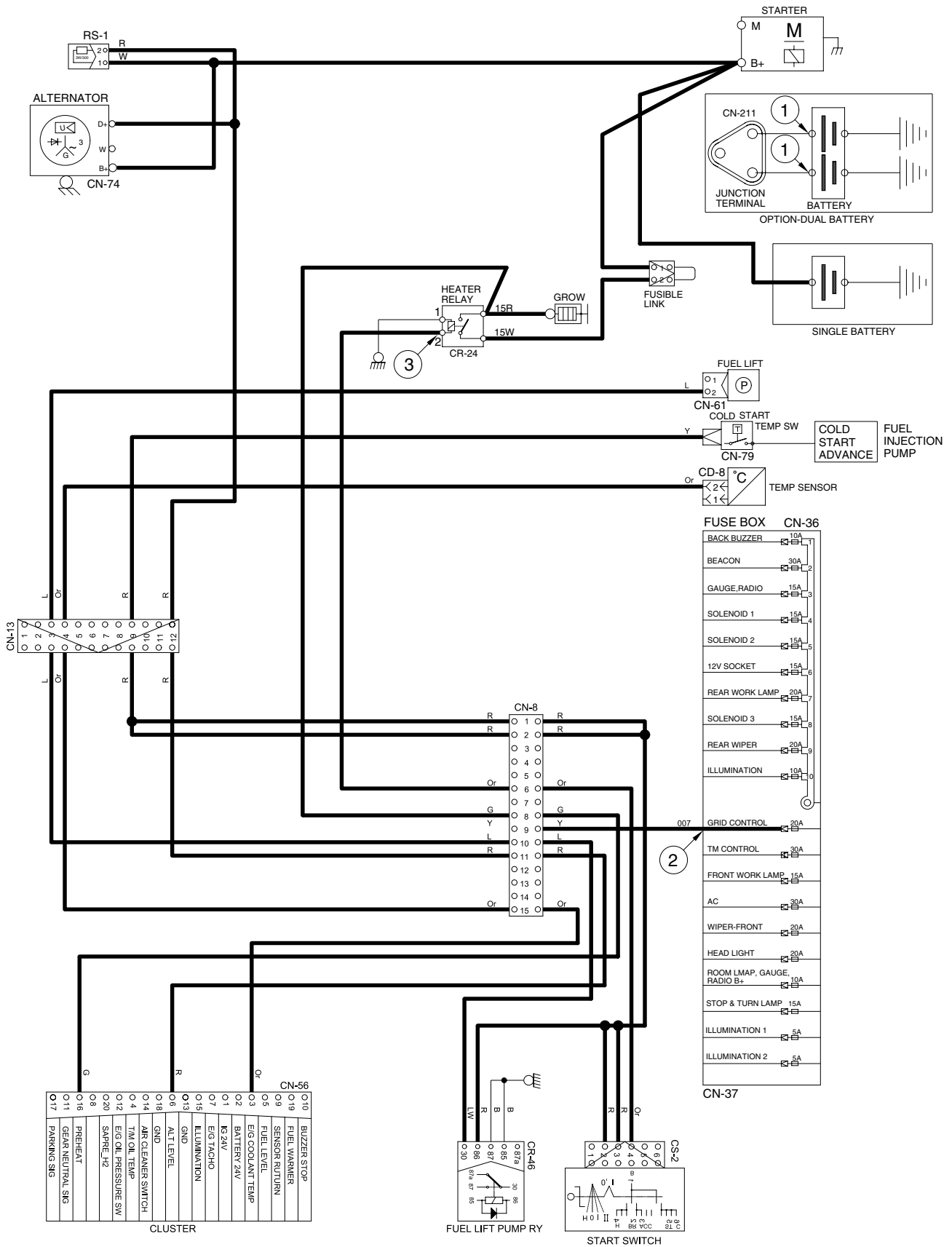

H940SEL09

7. ELECTRIC PARKING, DECLUTCH CIRCUIT

1) OPERATING FLOW

(1) Parking OFF

Fuse box [No.8] → Parking switch OFF [CS-17 (7)] → I/conn [CN-8 (13)]

→ T/M solenoid valve ON (activated) [Y-PB(1)] → Parking brake released (by hydraulic pressure)

(2) Parking ON

Fuse box [No.8] → Parking switch ON → [CS-17 (2)] → I/conn [CN-2C (3)]

→ Relay-K4 [CR-154 (3)→(5)]

→ Relay-K5 [CR-153 (3)→(5)]

→ Parking brake applied (by spring force)

(3) Declutch ON

Clutch cut-off switch ON [CS-61 (4)] → I/conn [CN-2C (4)] → DIODE 3 [(2)→(1)]

→ I/conn [CN-3 (1)] → Gear selector lever [CN-158 (7)]

2) CHECK POINT

Engine	Key switch	Check point	Voltage
Running	ON	① - GND (parking switch input) ② - GND (parking switch output) ③ - GND (parking solenoid) ④ - GND (clutch cut-off switch input)	12V

※ GND : Ground

ELECTRIC PARKING, PILOT CUT OFF CIRCUIT

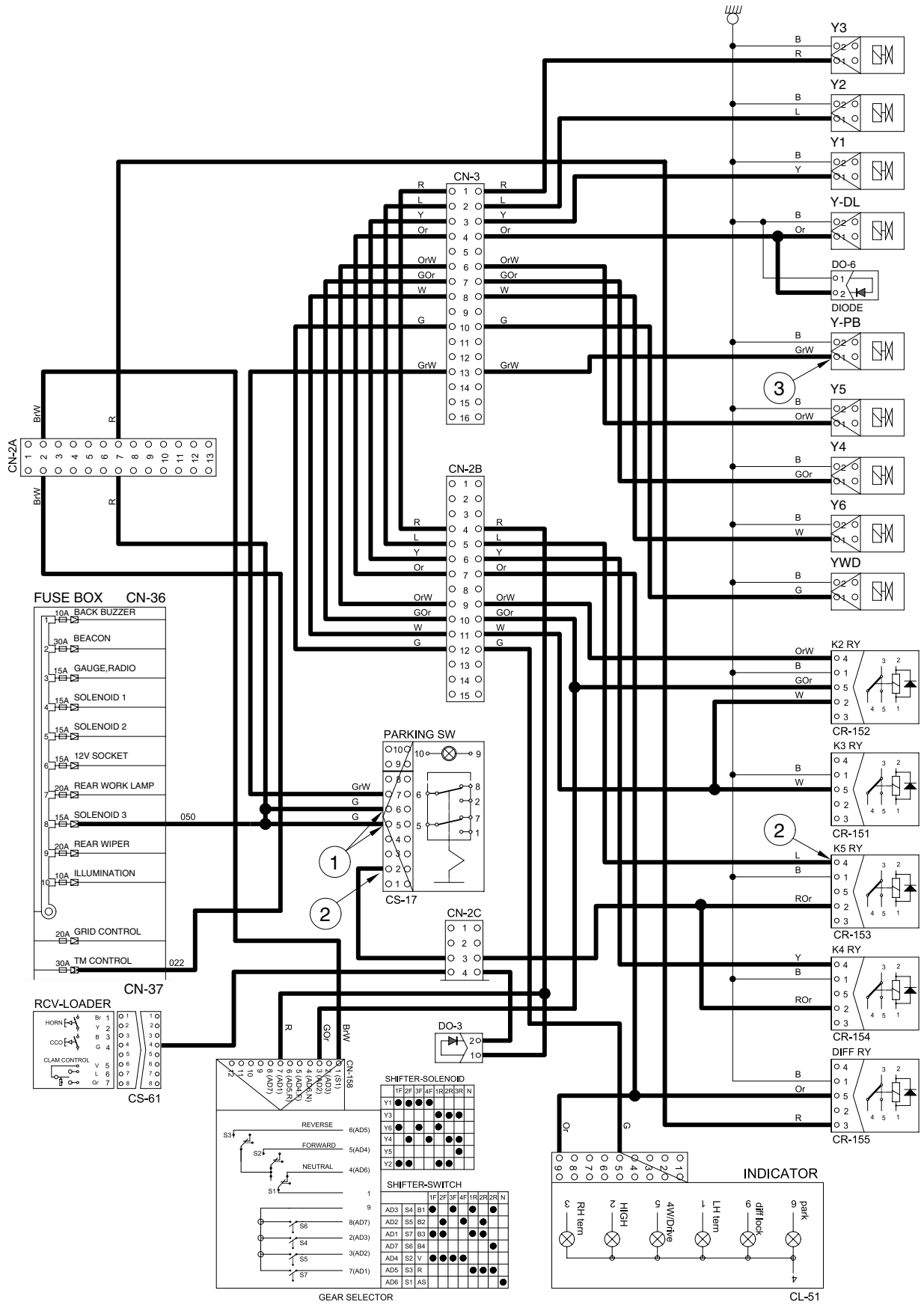

8. WIPER AND WASHER CIRCUIT

1) OPERATING FLOW

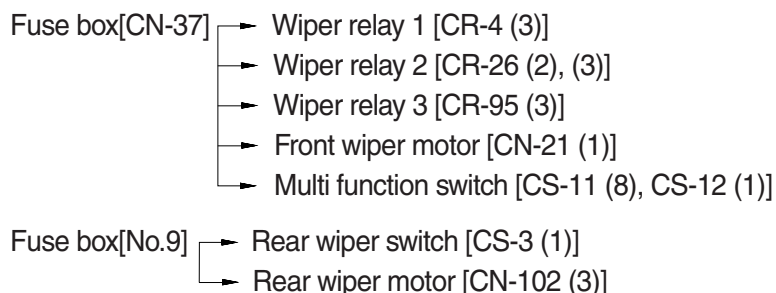

(1) Front washer switch ON

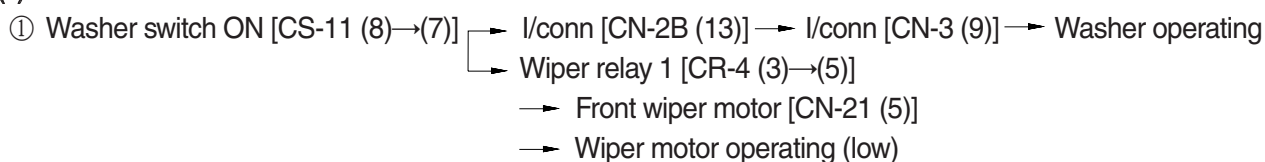

(2) Front wiper switch ON

① INT position

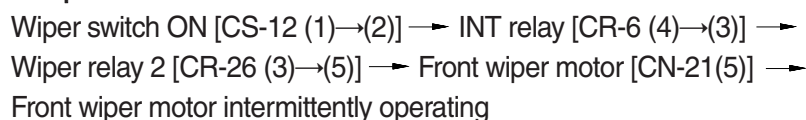

② Lo position

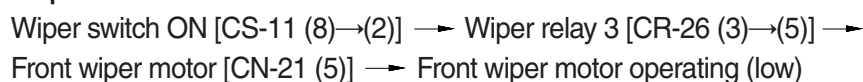

③ Hi position

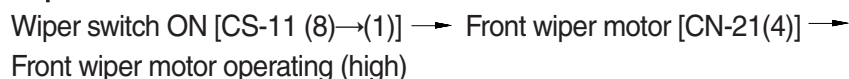

(3) Auto-parking (when switch OFF)

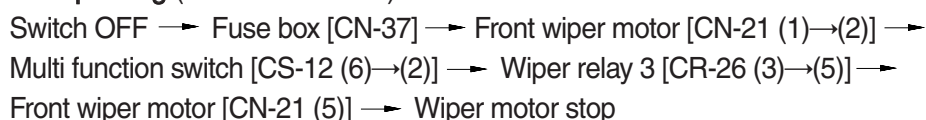

(4) Rear wiper and washer switch

① Wiper switch ON (1st step)

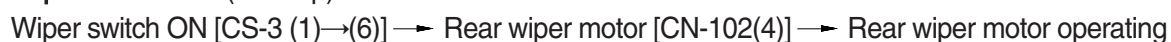

② Washer switch ON (2nd step)

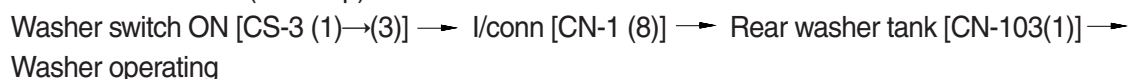

2) CHECK POINT

Condition	Check point	
Engine : Stop Key switch : ON Voltage : 12V	① - GND (front wiper switch power input)	⑥ - GND (front washer power output)
	② - GND (rear wiper switch power input)	⑦ - GND (rear washer power output)
	③ - GND (wiper relay power input)	⑧ - GND (front wiper motor power output)
	④ - GND (front wiper motor Lo power input)	⑨ - GND (rear wiper motor power output)
	⑤ - GND (front wiper motor High power input)	

※ GND : Ground

WIPER AND WASHER CIRCUIT

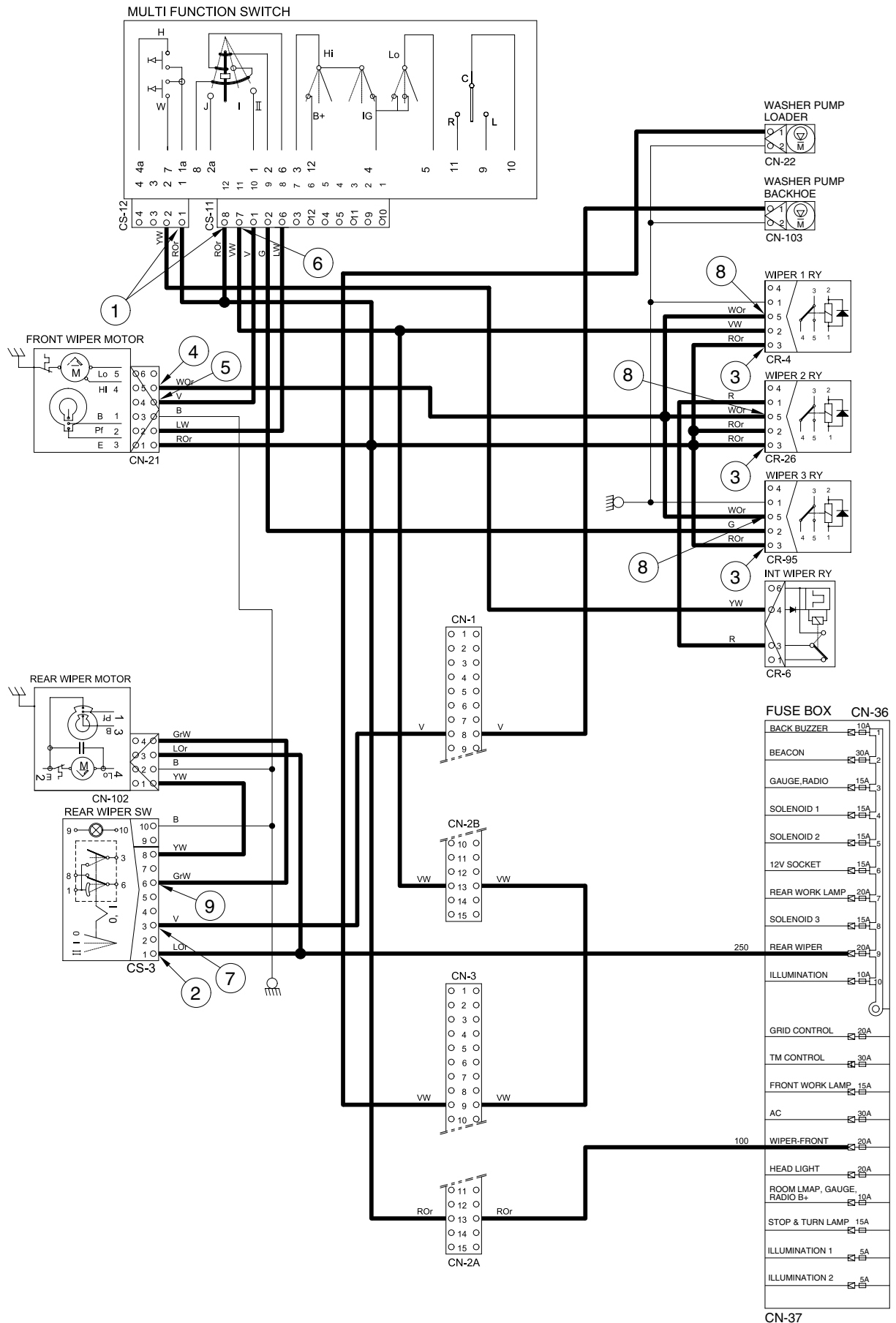

H940C7EL11

HAZARD, TURN AND ROTARY CIRCUIT

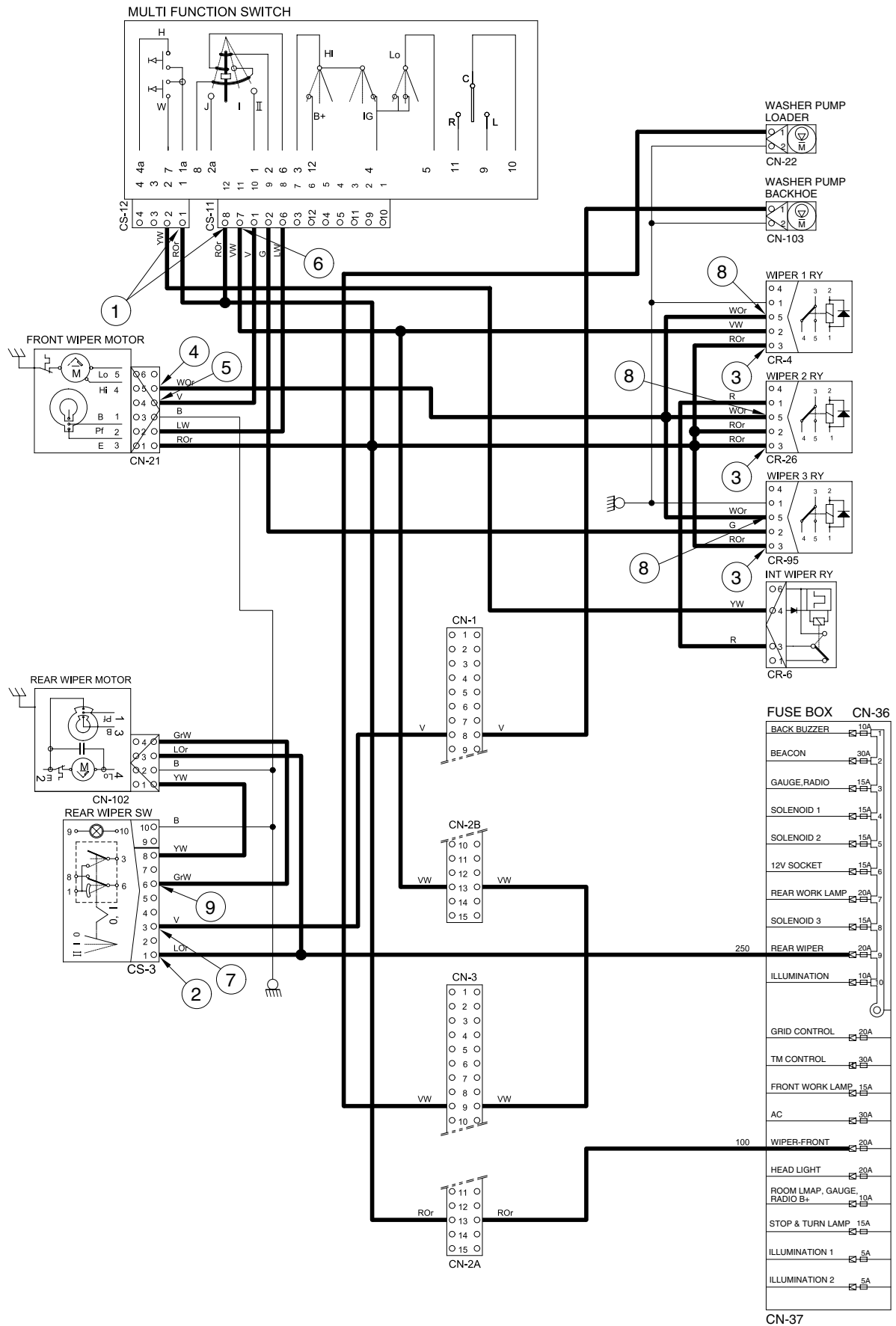

H940C7EL12