

GROUP 4 DISASSEMBLY AND ASSEMBLY

1. MAIN PUMP

1) STRUCTURE

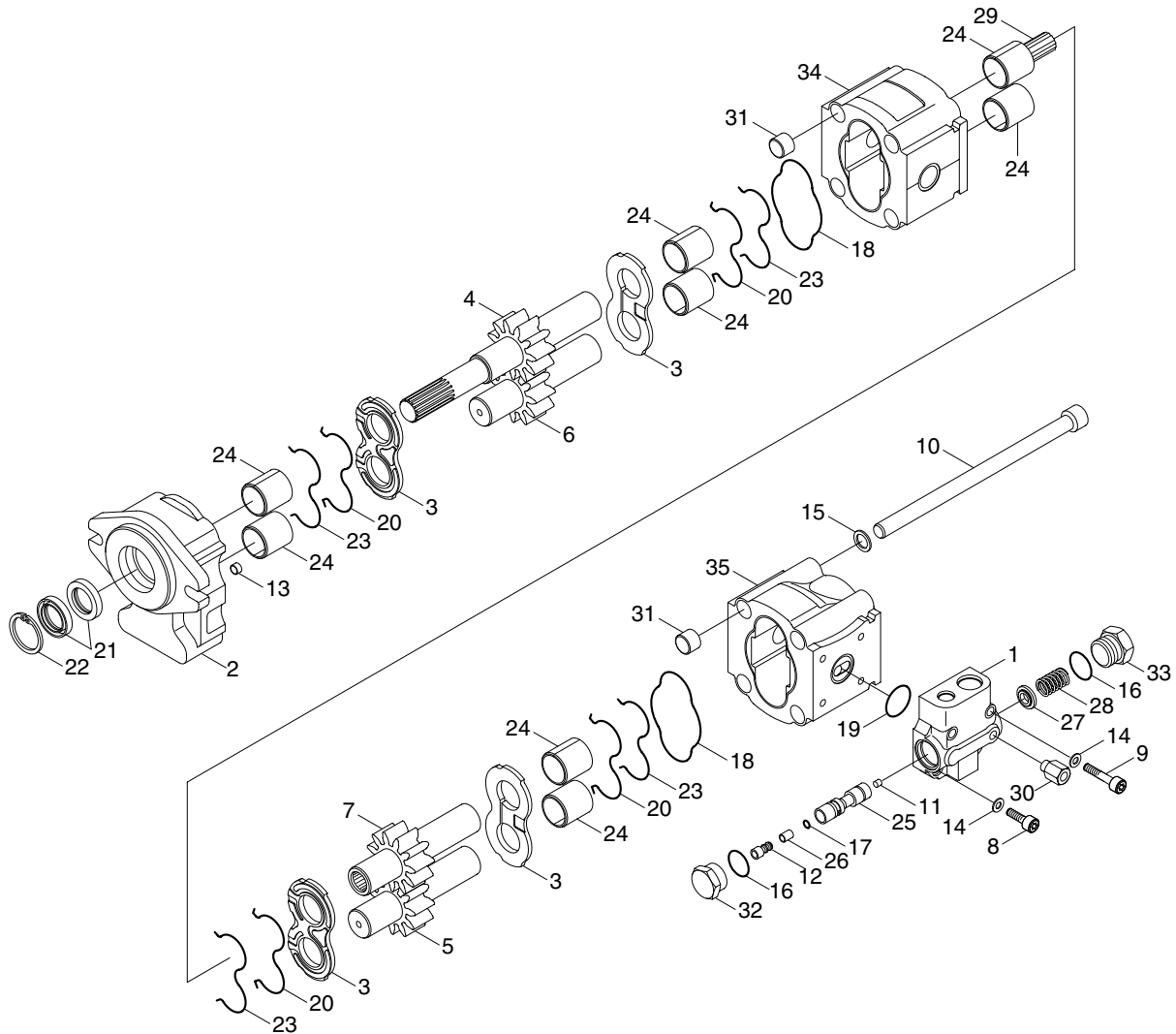

HB100WE21

1	Rear end cover	13	Screw	25	Spool
2	Front cover	14	Washer	26	Filter
3	Thrust plate	15	Washer	27	Spring seat
4	Drive shaft	16	O-ring seal	28	Spring
5	Driven gear	17	O-ring seal	29	Hub
6	Driven gear	18	Ring	30	Connector
7	Drive shaft	19	O-ring seal	31	Steel bushing
8	Screw	20	Seal	32	Plug
9	Screw	21	Shaft seal	33	Plug spring
10	Screw	22	Ring	34	Body
11	Screw	23	Ring	35	Body
12	Screw	24	Sleeve bearing		

2) GENERAL INSTRUCTIONS

- (1) Check immediately that any spare parts you receive have not been damaged in shipment.
- (2) Always work in a clean environment.
- (3) Wash all components in solvent and blow dry with compressed air before refitting.
- (4) Take care not to damage rubber seals.
- (5) Avoid damaging precision machined surfaces.
- (6) Components should fit into their housings without excessive force. If force is necessary, this normally means that the component does not have the correct dimensional tolerances or is aligned incorrectly.
- (7) When hand pressure is insufficient, only use presses or rubber hammer to fit components.
- (8) Never strike components with steel hammers.
- (9) Steel bushing must be fitted only with a suitable press.
- (10) Do not use hammers to fit bearings.
- (11) Always respect the direction of rotation when assembling components.

3) DISASSEMBLY

(1) LS priority valve

- ① Loosen and remove the assembling bolts and washers from the valve.



H940C6MP01

- ② Loosen and remove plug and take out spring & spool. (Only when it is needed to replace components inside).

- ※ Pay attention not to give any damage on the surface of the spool and contamination to the orifices prearranged at the spool.



H940C6MP02

(2) Mounting flange

- ① Loosen and remove the assembling bolts and washers from the pump.



H940C6MP03

- ② Remove mounting flange taking care to keep it as straight as possible during removal.

Tap around the edge with rubber mallet in order to break away from the body.

- ※ Ensure that while removing it, the drive shaft and other components remain position.

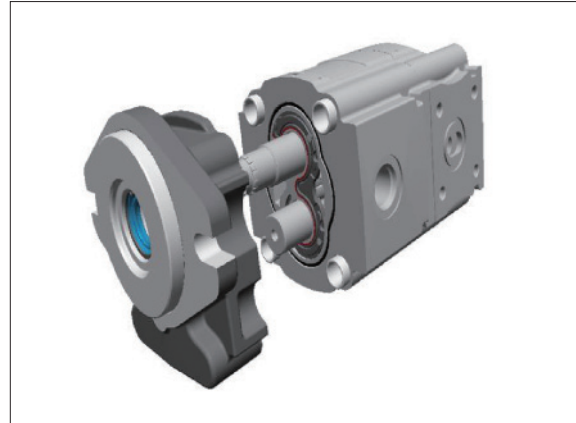

H940C6MP04

- ③ Remove shaft seal with (-) screwdriver and take out snap ring with proper tool and shaft seal again.

- ※ Take out the shaft seals only needed. Shaft seals disassembled from the mounting flange is not reusable.



H940C6MP05

(3) 1st working section

- ① Remove the pressure plate with prearranged parts, O-ring & back up ring from the working section and examine it carefully.



H940C6MP06

- ② Pull out driving gear & driven gear keeping gears as straight as possible.
- ③ Remove other pressure plate on rear side with same way for front side.

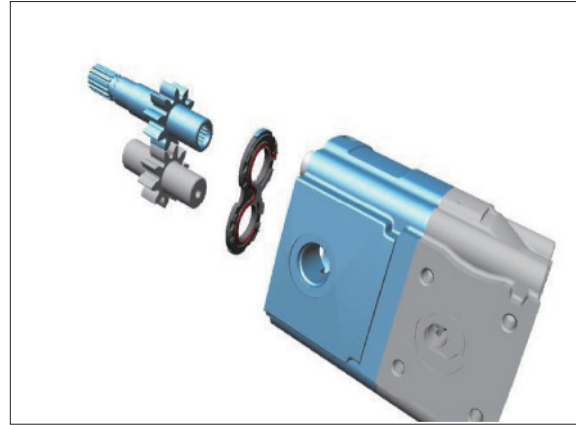

H940C6MP07

- ④ Remove square O-ring on the groove of body.
- ⑤ Remove through shaft and front body.
- ※ Tap around marked points with rubber mallet all around to break away first body from second.
Do not wedge between the bodies, it may give serious damage on the surface.

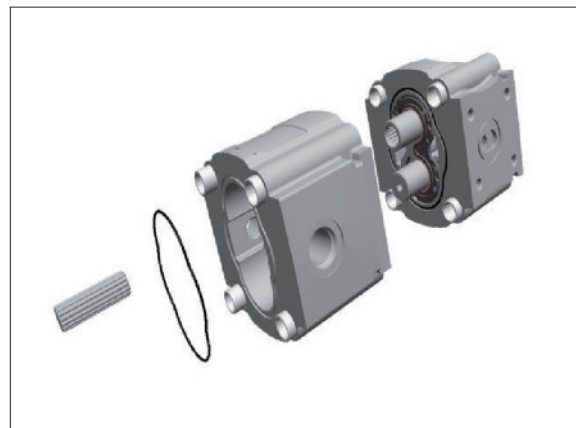

H940C6MP08

(4) 2nd working section

- ① Remove all components inside of second body with same way for 1st section.
- ② Remove the square O-ring if necessary.



H940C6MP09

4) ASSEMBLY

(1) Preassembly

Pressure plates

- ① Locate O-ring into the groove on the aluminum pressure plate.
- ② Locate back-up ring upon the O-ring.
- ③ Smear clean grease on the O-ring & back-up ring to fix their position while moving.



H940C6MP10

Working body

- ① Insert square rings into grooves.
Shape of square ring is different depend on type of bodies.

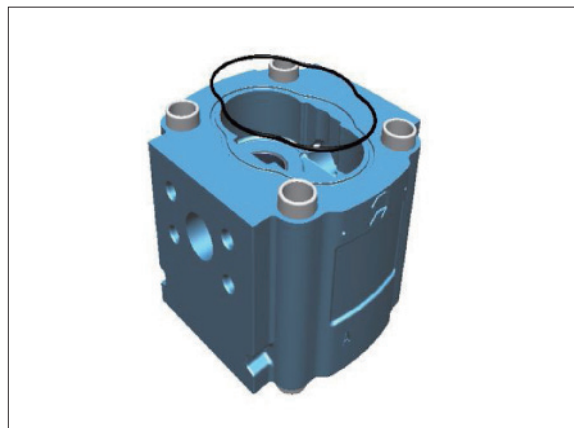

H940C6MP11

Mounting flange

- ① Locate shaft seal inside shaft hole to the end.
- ② Insert snap ring and locate it into the groove prearranged on the mounting flange.
- ③ Locate shaft seal again but different direction.



H940C6MP12

LS - priority valve

① Insert the spool prearranged all orifice first, and spring, plugs.

- Torque value of both sides plugs :
10.2 kgf · m (73.8 lbf · ft)
- Torque value of LS plug :
1.53 kgf · m (11.1 lbf · ft)

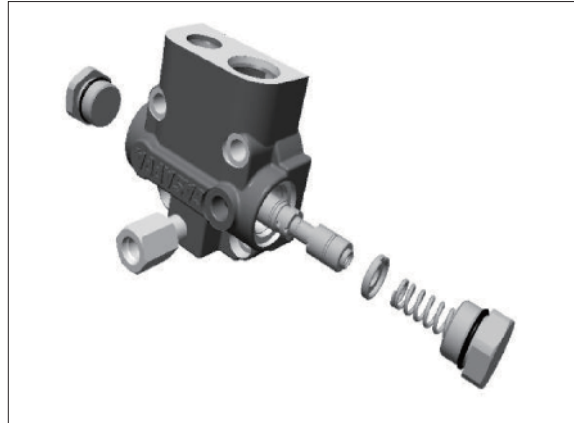

H940C6MP13

(2) Assembling

① Prepare cleaned 2nd body prearranged guard pins and square O-ring.

② Insert a pressure plate prearranged O-ring & back-up ring inside of body.

※ Opened area of O-ring should face to suction side. And O-ring side should face to the body.



H940C6MP14

③ Locate driving gear and driven gear keeping as straight as possible during assembling.

④ Locate one of pressure plates prepared.

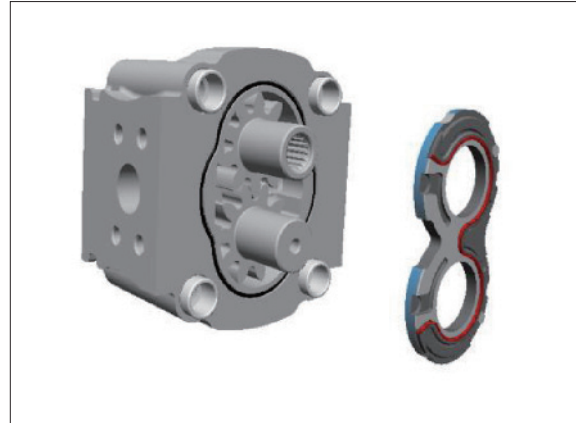

H940C6MP15

⑤ Locate 1st body on the 2nd body tapping around the body with rubber mallet to fit it completely.

⑥ Locate through shaft on the driving gear.

⑦ Locate pressure plate with same way for 2nd body.

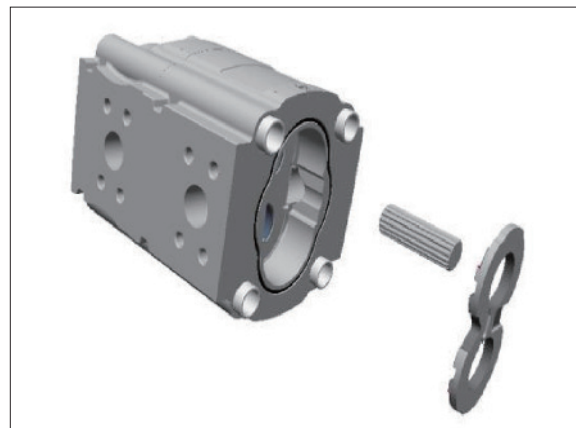

H940C6MP16

⑧ Locate driving gear and driven gear and last pressure plate also.

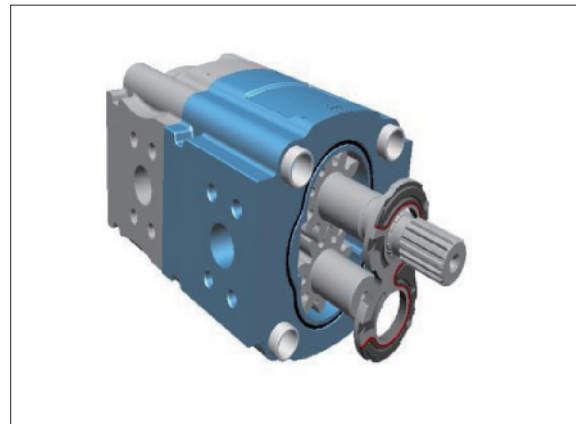

H940C6MP17

- ⑨ Assemble mounting flange to the body, taking care not to give any damage on the shaft seals by sharp edge of shaft.

※ Smear clean grease on the lips of shaft seals before assembling.



H940C6MP18

- ⑩ Assemble the bolts and tighten the bolts with in a crisscross pattern to a torque value of 14.3 kgf · m (103 lbf · ft).

- ⑪ Check that the pump rotates freely when the drive shaft is turned by hand, if not a possible, plate seal may be pinched.

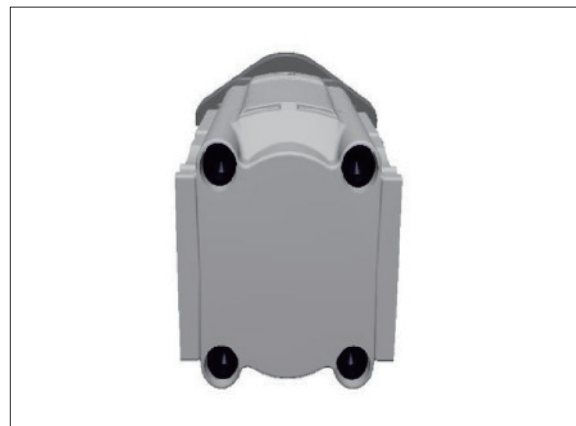

H940C6MP19

- ⑫ Locate an O-ring into the groove on the body.

- ⑬ Locate preassembled LS - priority valve on the 1st working section and tighten the bolts with in a crisscross pattern to a torque value of 7.14 kgf · m (51.6 lbf · ft).



H940C6MP20

2. LOADER MAIN CONTROL VALVE

1) STRUCTURE

(1) Mechanical control

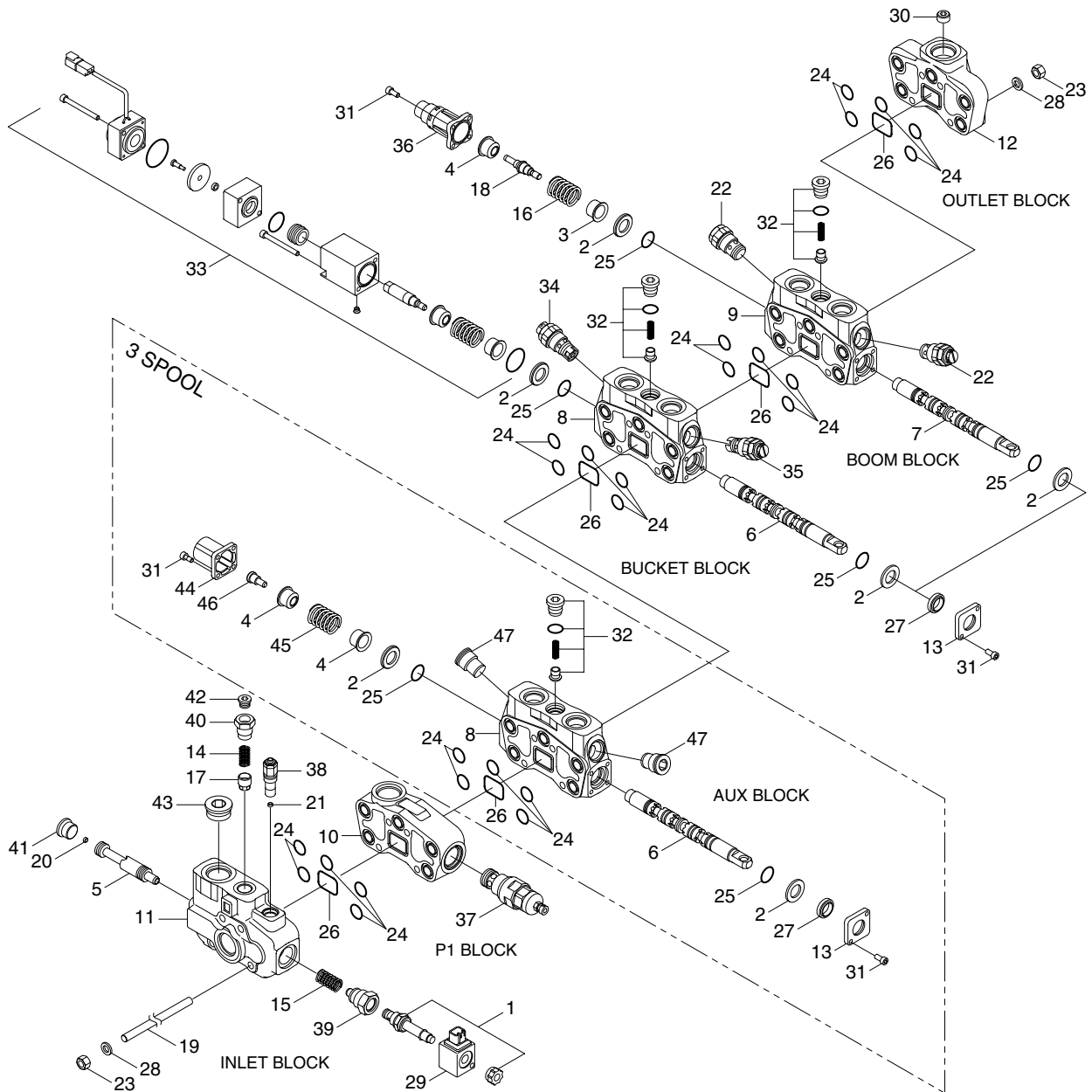

H940C6WE36

1 Solenoid valve	14 Spring	25 Seal	37 Valve
2 Spacer	15 Spring	26 O-ring	38 Cartridge
3 Bushing	16 Spring (B type)	27 Seal	39 Inlet cover joint
4 Bushing control kit	17 Poppet	28 Spring washer	40 Adapter
5 Unloader spool	18 Detent kit	29 Body	41 Plug
6 Spool	19 Tie rod	30 Conical plug	42 Plug
8 Element	20 Screw	31 Screw	43 Plug
9 Element	21 Screw	32 Check valve	44 End cap
10 Element	22 Cartridge	34 Valve	45 Spring
11 Inlet cover	23 Nut	35 Valve	46 Screw
12 Outlet cover	24 O-ring	36 Cover kit	47 Plug
13 Flange			

(2) Pilot control

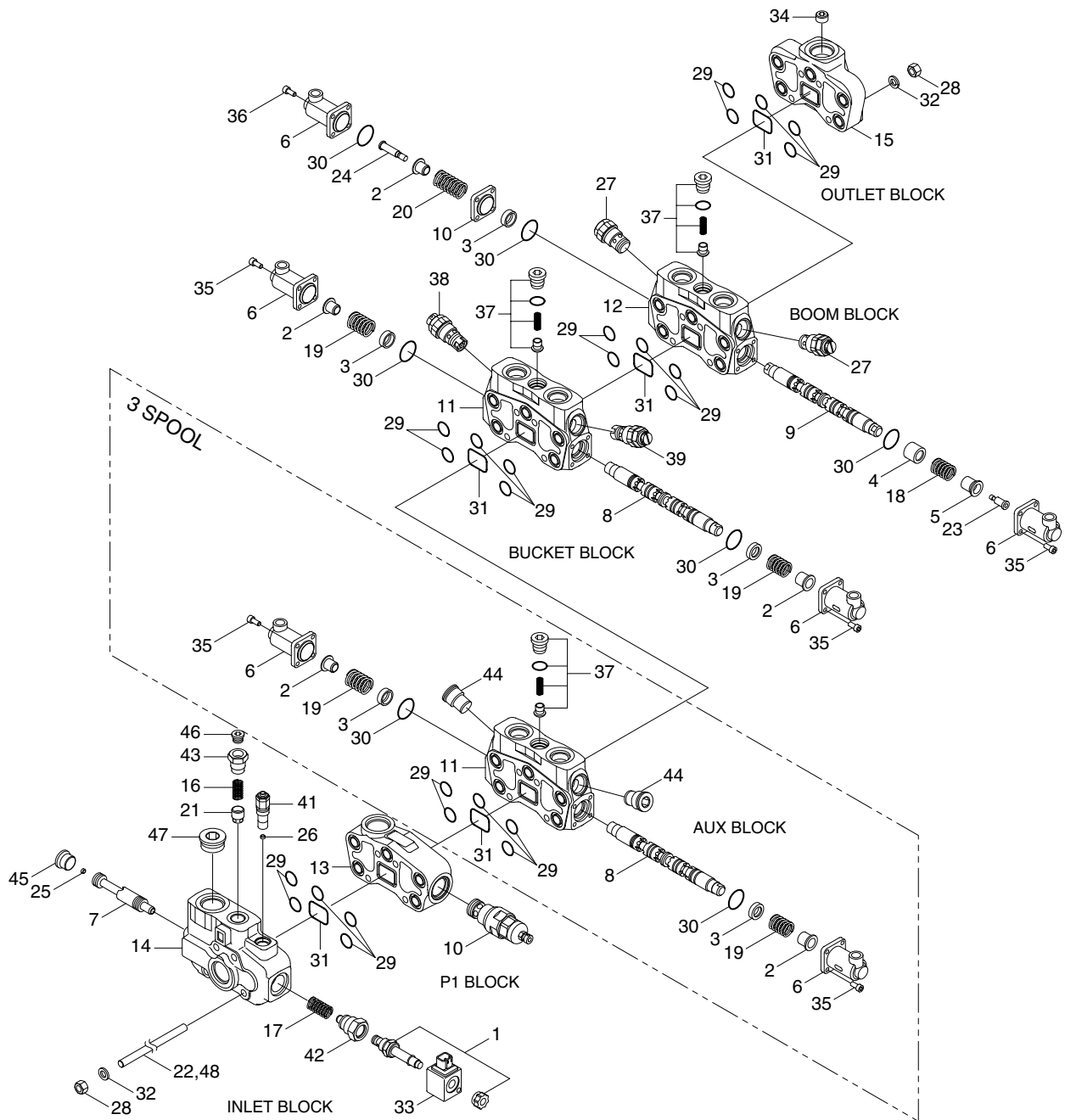

H940C6WE37

1	Solenoid valve	13	Element	25	Screw	37	Check valve
2	Spring cap	14	Inlet cover	26	Screw	38	Valve
3	Bushing	15	Outlet cover	27	Cartridge	39	Valve
4	Bushing	16	Spring	28	Nut	40	Valve
5	Bushing	17	Spring	29	O-ring	41	Cartridge
6	Cap	18	Spring	30	O-ring	42	Inlet cover joint
7	Spool	19	Spring	31	O-ring	43	Adapter
8	Spool	20	Spring control kit	32	Spring washer	44	Plug
9	Spool	21	Poppet	33	Coil	45	Plug
10	Spacer	22	Tie rod	34	Conical plug	46	Plug
11	Element	23	Screw	35	Bolt	47	Plug
12	Element	24	Screw	36	Screw		

2) INITIAL SETUP OF THE VALVE ON ASSEMBLY BENCH

- (1) Clean the table.
- (2) Wear safety goggles.
- (3) Place the stacked valve with inlet to the left side as shown in the picture.
- (4) Clean the valve using compressed air so that valve is free from any dust or dirt.



3) CHECK VALVE ASSEMBLY

- (1) Assemble the check valve into the check valve cavity.
- (2) Make sure that O-ring is present in the check valve.



- (3) Tighten in to 4.28 kgf · m (31 lbf · ft) torque (wrench 08) using pneumatic torque gun.



4) P PORT PLUG ASSEMBLY

- (1) Close the top inlet port with SAE 16 plug and tighten it to 4.28 kgf · m (31 lbf · ft) torque (wrench 12) using pneumatic torque gun. (Make sure that O-ring is present in the plug.)





5) MANOMETER PLUG ASSEMBLY

- (1) Insert the poppet in the manometer cavity.
- (2) Then insert the spring on to the poppet.



- (3) Insert the spacer on top of the spring.

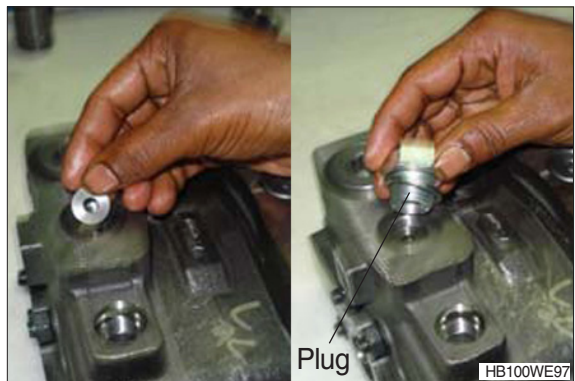

- (4) Assemble the BSP 1/2" plug and tighten it to 4.28 kgf · m (31 lbf · ft) torque (wrench 27) using pneumatic torque gun. (Make sure that washer is present in the plug.)



6) PRIORITY INLET SPOOL ASSEMBLY

- (1) Insert orifice of (\varnothing 0.75 mm) in the spool as shown in picture.
- (2) Lubricate the spool cavity with hypsin VG46.



- (3) Insert the spool into the spool cavity with orifice face should go inside.



- (4) Insert the spring on to the spool seat.



- (5) Assemble the adapter and tighten it to 4.28 kgf · m (31 lbf · ft) torque (wrench 32) using pneumatic torque gun. (Make sure that washer & O-rings are present in the adapter.)

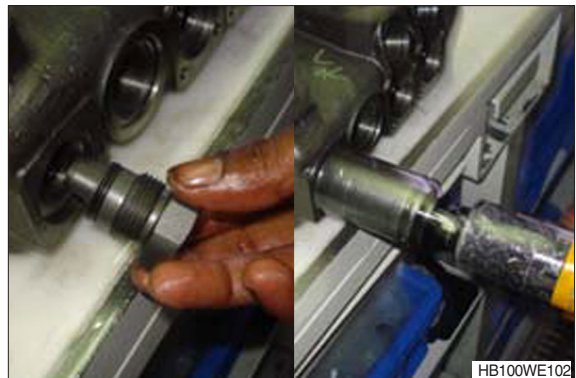

- (6) Plug the other side of the spool cavity with M22×1.5 mm plug and tighten it to 4.28 kgf · m (31 lbf · ft) torque (wrench 12) using pneumatic torque gun. (Make sure that O-ring is present in the adapter.)

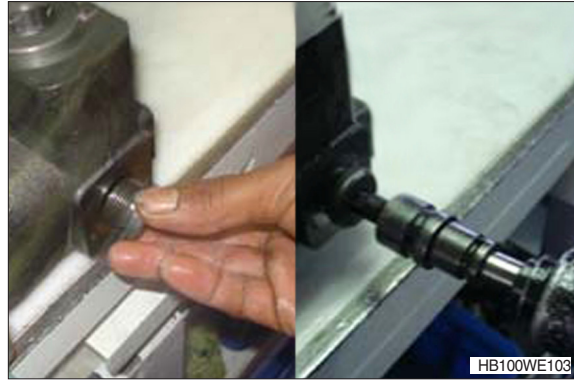

7) UNLOADING SOLENOID VALVE ASSEMBLY

- (1) Assemble the solenoid as shown in the picture and tighten it to 5.10 kgf · m (36.9 lbf · ft) torque (wrench 24) using pneumatic torque gun.

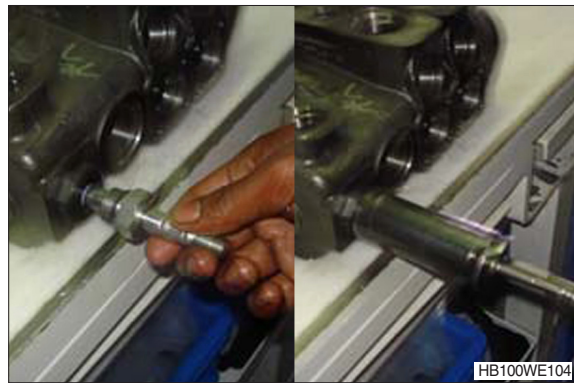

- (2) Insert the coil into the solenoid.
(3) Assemble the insulator.

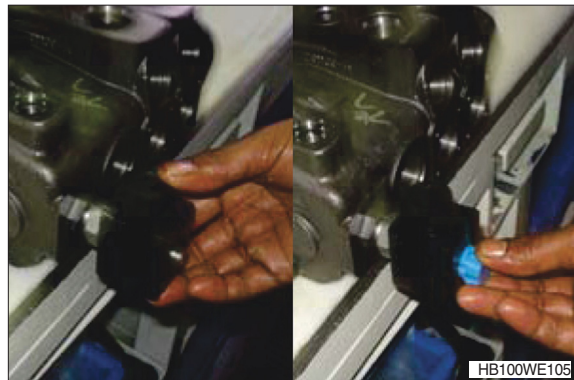

8) LS VALVE ASSEMBLY

- (1) Insert orifice of (∅ 1.25 mm) in the LS cavity as shown in picture.



- (2) Assemble the LS valve into LS cavity and tighten it to 2.45 kgf · m (17.7 lbf · ft) torque (wrench 19) using pneumatic torque gun.

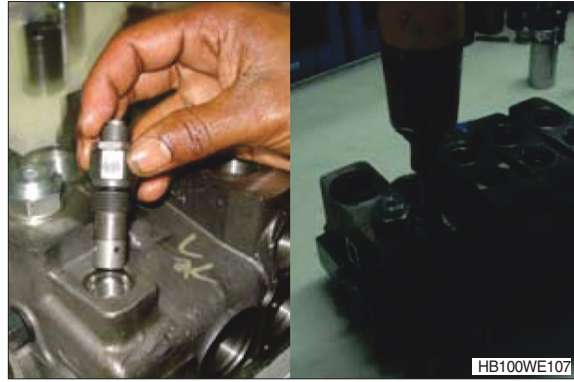

9) MAIN RELIEF VALVE ASSEMBLY

- (1) Assemble main relief valve into the main relief valve cavity as shown in picture and tighten it to 4.28 kgf · m (31 lbf · ft) torque (wrench 36) using pneumatic torque gun.

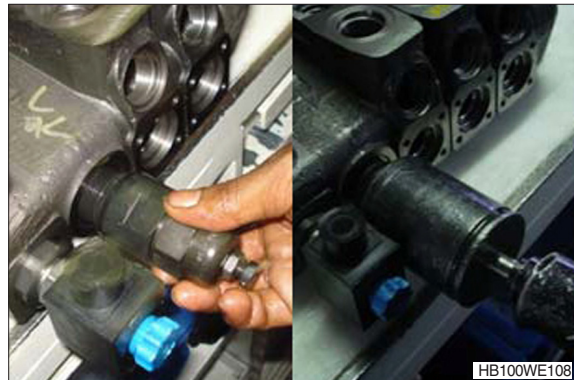

10) PORT RELIEF VALVE ASSEMBLY

- (1) Assemble the port relief valve into the port relief valve cavity as describe below and tighten it to 2.45 kgf · m (17.7 lbf · ft) torque (wrench 19) using pneumatic torque gun.

- 1st section (from inlet) : ZTAL-00195
- 2nd section (bucket) : ZTAL-00305/00306
- 3rd section (boom) : ZTAL-00148



11) PORT RELIEF VALVE CAVITY PLUG ASSEMBLY

- (1) Plug remaining port relief cavities with P3T plugs (i.e. on B1 & B2 port) and tighten it to 4.28 kgf · m (31 lbf · ft) torque (wrench 12) using pneumatic torque gun.



12) SPOOL ASSEMBLY

- (1) Lubricate all the spool cavities with hypsin VG46.
- (2) Insert spool as describe below with eye end of the spool is on the lever side.
 - 1st section (Aux) :
ZTAL-00167 (mechanical)
ZTAL-00293 (pilot)
 - 2nd section (bucket) :
ZTAL-00167 (mechanical)
ZTAL-00293 (pilot)
 - 3rd section (boom) :
ZTAL-00168(mechanical)
ZTAL-00308 (pilot)
- (3) Move the spools in and out two to three times for free movement.

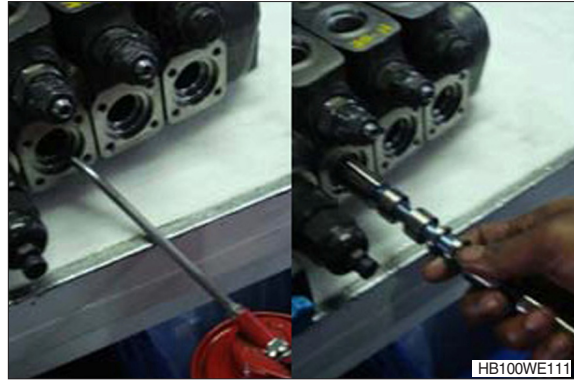

13) O-RING AND SPACER ASSEMBLY ON CONTROL KIT SIDE

- (1) Assemble the O-ring in the O-ring groove as shown in the picture.
- (2) Assemble the spacer into the spacer groove provided in spool cavity (chamfered face should go inside the cavity).



14) CONTROL KIT ASSEMBLY ON BOTH SIDE OF THE VALVE

- (1) Apply a drop of loctite #270 thread locker on control kit screw threads.
- (2) Place control kit spring in between two bushes as shown, and then assemble these into the spool with control kit screw.



- (3) Tighten the control kit to $0.99 \text{ kgf} \cdot \text{m}$ ($7.16 \text{ lbf} \cdot \text{ft}$) torque (wrench 04) using pneumatic torque gun.
- (4) Lubricate the proper quantity of grease to all control kits.

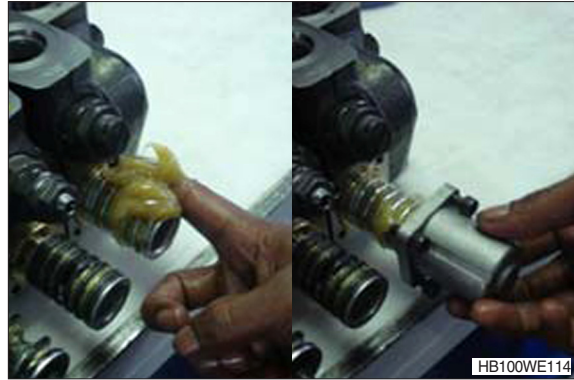

- (5) Assemble the end cap with M6 screws and tighten to $0.67 \text{ kgf} \cdot \text{m}$ ($4.85 \text{ lbf} \cdot \text{ft}$) torque using pneumatic torque gun.

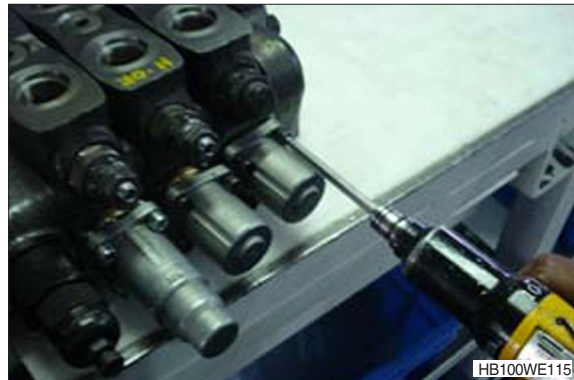

15) LEVER KIT ASSEMBLY

- (1) Assemble the O-ring in the O-ring groove as shown in the picture.
- (2) Assemble the spacer into the spacer groove provided in spool cavity (chamfered face should go inside the cavity)



- (3) Assemble lever cap and tighten it with M6 screws to $0.99 \text{ kgf} \cdot \text{m}$ ($7.16 \text{ lbf} \cdot \text{ft}$) torque using pneumatic torque gun.



16) RE PLUG ASSEMBLY

- (1) Assemble the RE plug (M18 × 1.5 mm) in tank port as shown in the picture and tighten it with allen key.



17) COMPLETE VALVE ASSEMBLY



3. BACKHOE MAIN CONTROL VALVE

1) STRUCTURE

(1) Mechanical control (1/3)

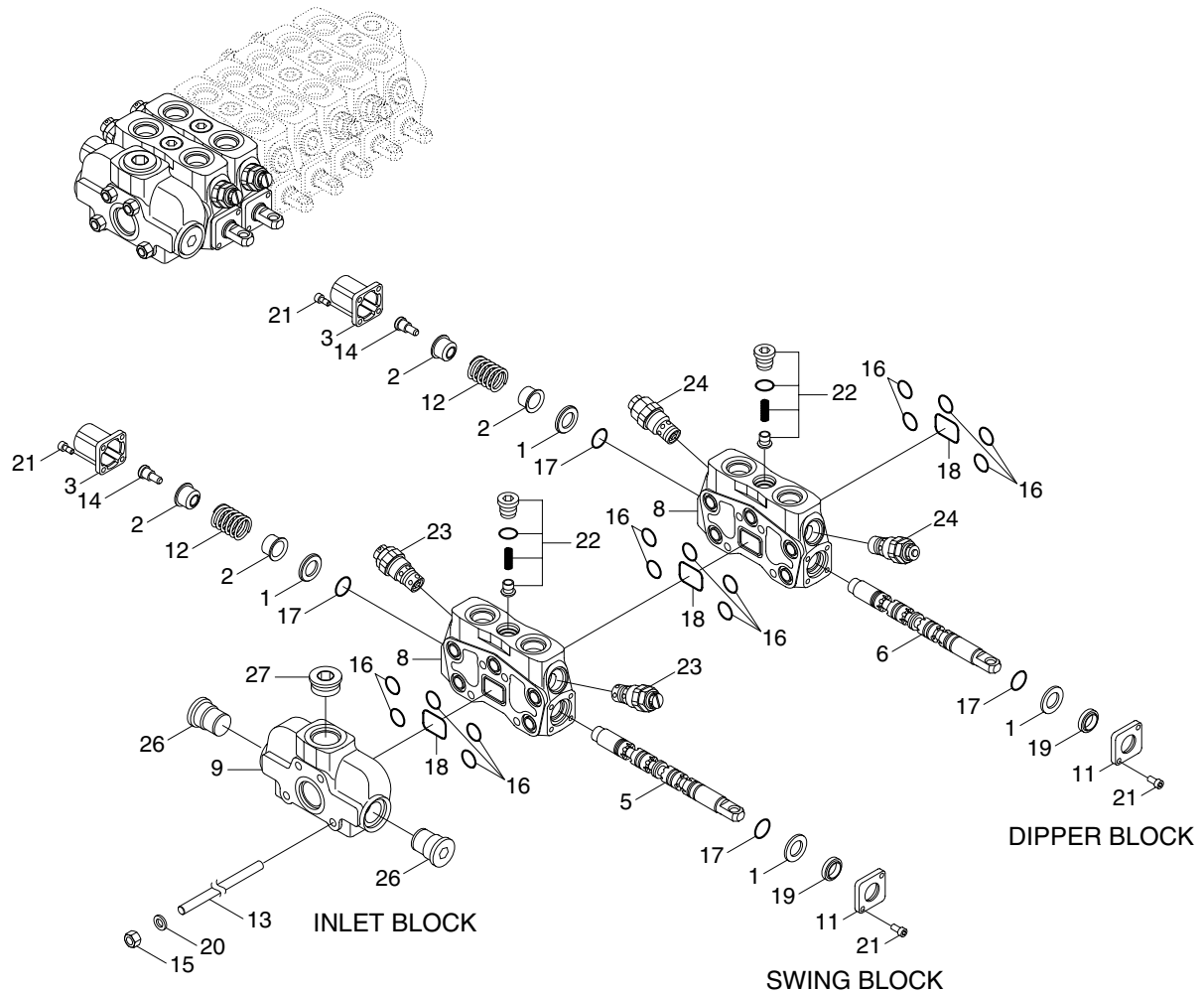

- | | | | | | |
|----|---------------------|----|-------------|----|---------------|
| 1 | Spacer | 12 | Control kit | 20 | Spring washer |
| 2 | Bushing control kit | 13 | Tie rod | 21 | Screw |
| 3 | End cap | 14 | Screw | 22 | Check valve |
| 5 | Spool | 15 | Nut | 23 | Relief valve |
| 6 | Spool | 16 | O-ring | 24 | Relief valve |
| 8 | Block | 17 | Seal | 26 | Plug assembly |
| 9 | Inlet cover | 18 | O-ring | 27 | Plug |
| 11 | Flange | 19 | Seal | | |

H940C6WE33

Mechanical control (2/3)

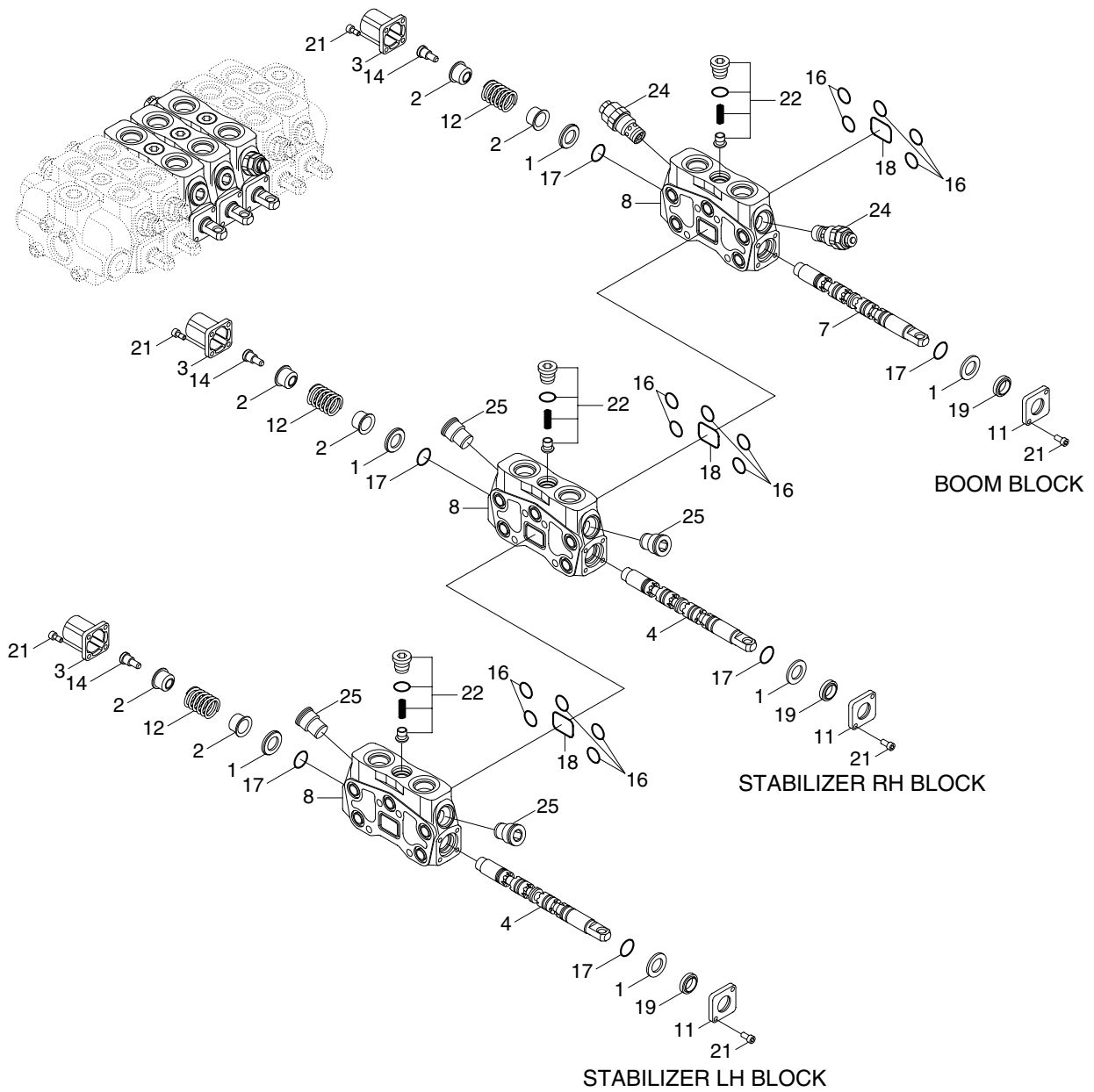

- 1 Spacer
- 2 Bushing control kit
- 3 End cap
- 4 Spool
- 7 Spool
- 8 Block

- 11 Flange
- 12 Control kit
- 14 Screw
- 16 O-ring
- 17 Seal
- 18 O-ring

- 19 Seal
- 21 Screw
- 22 Check valve
- 24 Relief valve
- 25 Plug

H940C6WE34

Mechanical control (3/3)

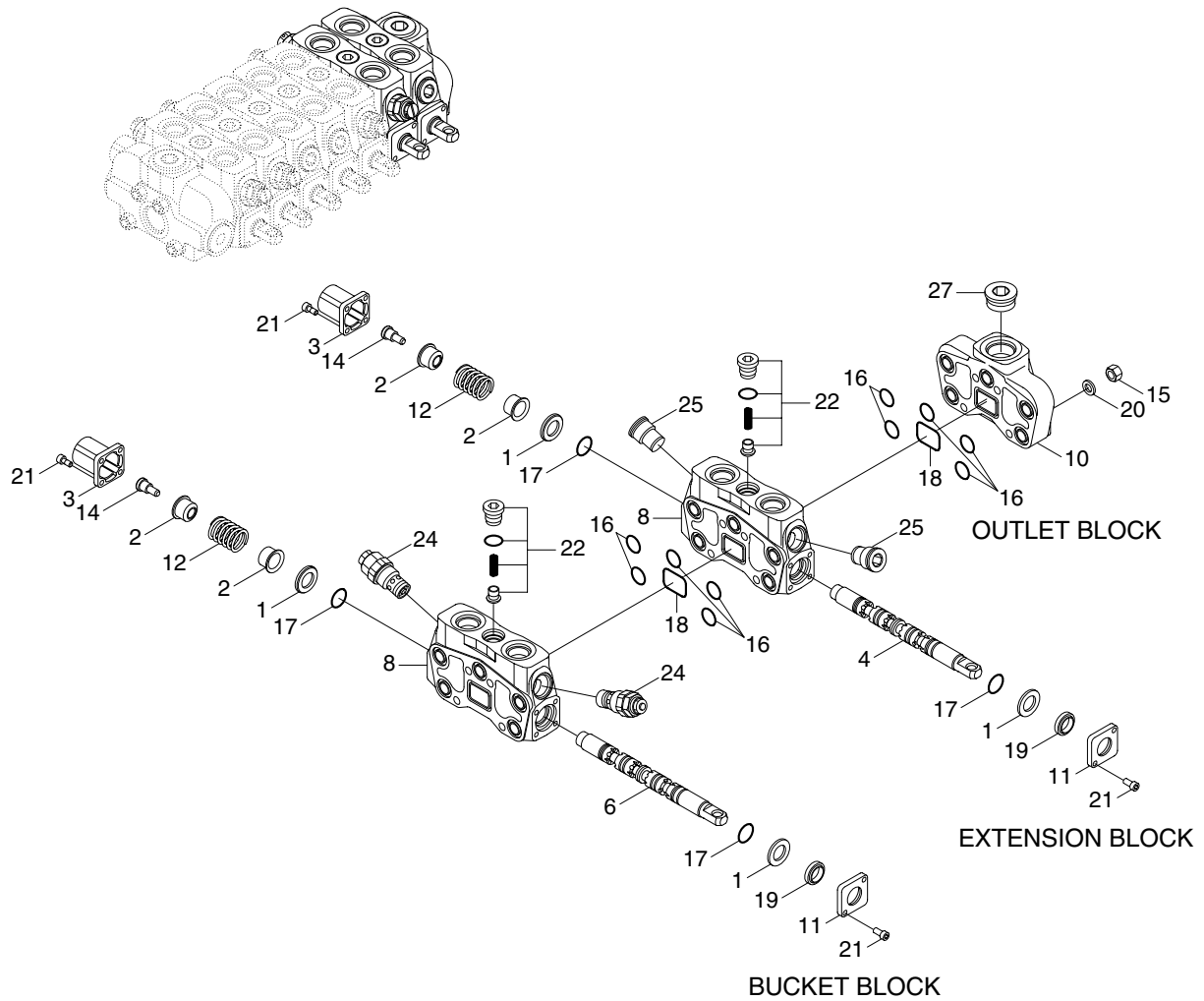

- | | | | | | |
|----|---------------------|----|-------------|----|---------------|
| 1 | Spacer | 11 | Flange | 19 | Seal |
| 2 | Bushing control kit | 12 | Control kit | 20 | Spring washer |
| 3 | End cap | 14 | Screw | 21 | Screw |
| 4 | Spool | 15 | Nut | 22 | Check valve |
| 6 | Spool | 16 | O-ring | 24 | Relief valve |
| 8 | Block | 17 | Seal | 25 | Plug |
| 10 | Outlet cover | 18 | O-ring | 27 | Plug |

H940C6WE35

(2) Pilot control (1/3)

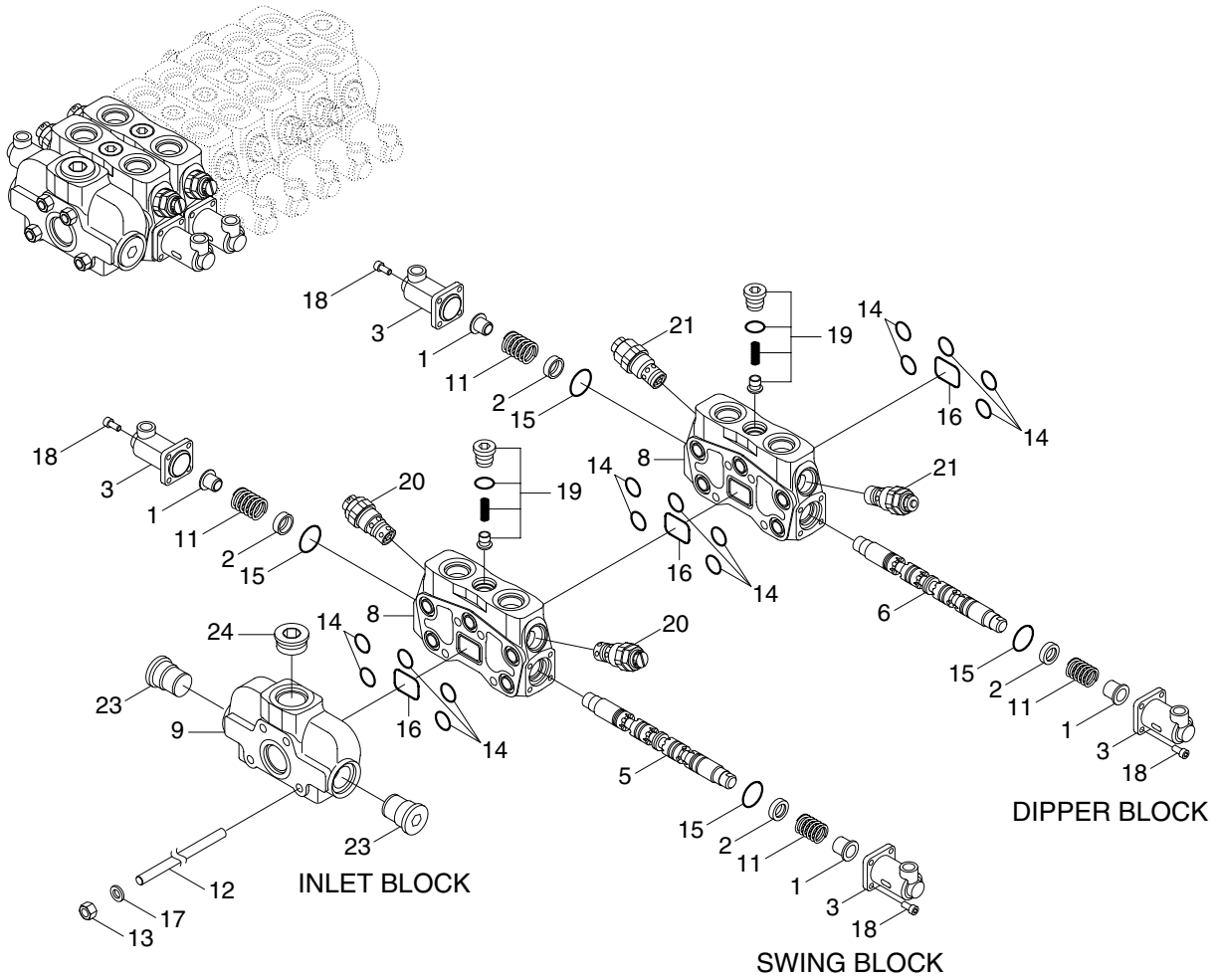

- | | | | | | |
|---|-------------|----|---------|----|---------------|
| 1 | Spring cap | 11 | Spring | 17 | Spring washer |
| 2 | Bushing | 12 | Tie rod | 18 | Bolt |
| 3 | End cap | 13 | Nut | 19 | Check valve |
| 5 | Spool | 14 | O-ring | 20 | Relief valve |
| 6 | Spool | 15 | O-ring | 21 | Relief valve |
| 8 | Block | 16 | O-ring | 23 | Plug assembly |
| 9 | Inlet cover | | | | |

H940C6WE40

Pilot control (2/3)

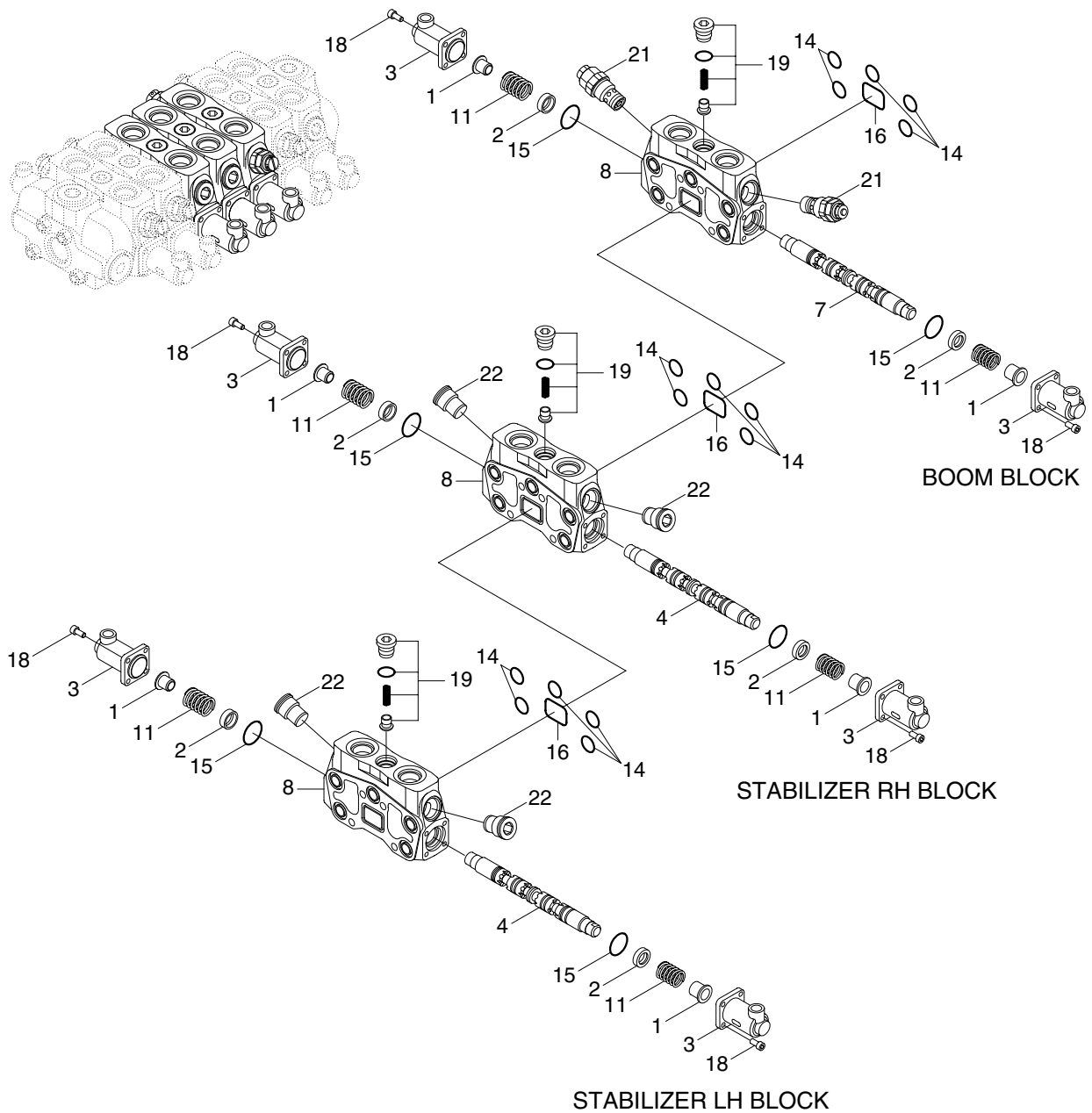

- 1 Spring cap
- 2 Bushing
- 3 End cap
- 4 Spool
- 7 Spool

- 8 Block
- 11 Spring
- 14 O-ring
- 15 O-ring
- 16 O-ring

- 18 Bolt
- 19 Check valve
- 21 Relief valve
- 22 Plug

H940C6WE41

Pilot control (3/3)

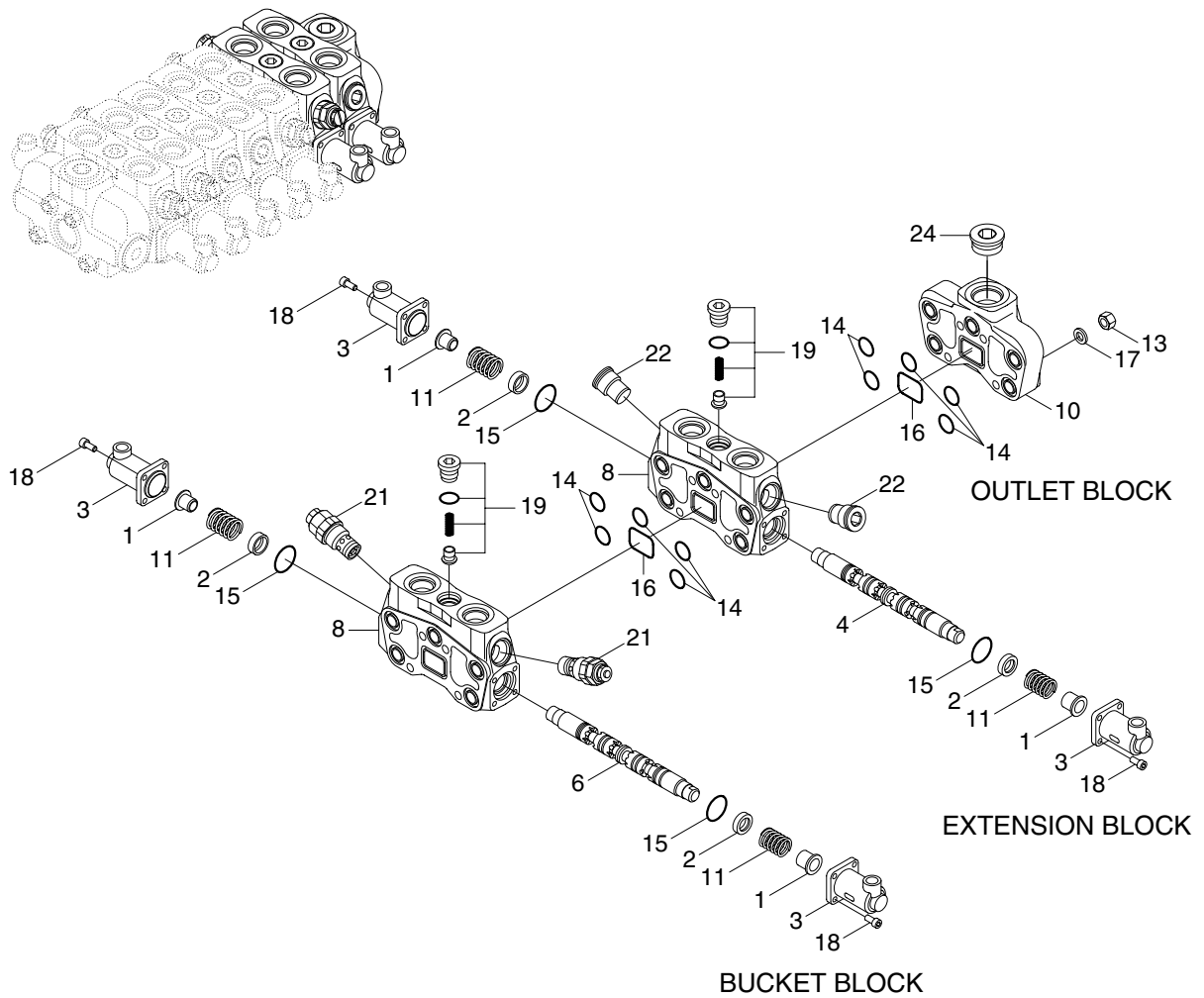

- | | | | | | |
|---|------------|----|--------------|----|---------------|
| 1 | Spring cap | 10 | Outlet cover | 17 | Spring washer |
| 2 | Bushing | 11 | Spring | 18 | Bolt |
| 3 | End cap | 13 | Nut | 19 | Check valve |
| 4 | Spool | 14 | O-ring | 21 | Relief valve |
| 6 | Spool | 15 | O-ring | 22 | Plug |
| 8 | Block | 16 | O-ring | 24 | Plug |

H940C6WE42

2) INITIAL SETUP OF THE VALVE ON ASSEMBLY BENCH

- (1) Clean the table.
- (2) Wear safety goggles.
- (3) Place the stacked valve with inlet to the left side as shown in the picture.
- (4) Clean the valve using compressed air so that valve is free from any dust or dirt.



3) LOAD DROP CHECK VALVE ASSEMBLY

- (1) Assemble the check valve into the check valve cavity.
- (2) Make sure that O-ring is present in the check valve.



- (3) Tighten in to 4.28 kgf · m (31 lbf · ft) torque (wrench 08) using pneumatic torque gun.



4) P AND T PORT PLUG ASSEMBLY

- (1) Close the top inlet port and top outlet port with SAE 16 plug and tighten it to 4.28 kgf · m (31 lbf · ft) torque (wrench 17) using pneumatic torque gun. (Make sure that O-ring is present in the plug.)





5) F KIT ASSEMBLY

(1) Insert the F kit in the F kit cavity.



(2) Assemble the F plug and tighten it to 4.28 kgf · m (31 lbf · ft) torque (wrench 32) using pneumatic torque gun. (Make sure that washer is present in the plug.)

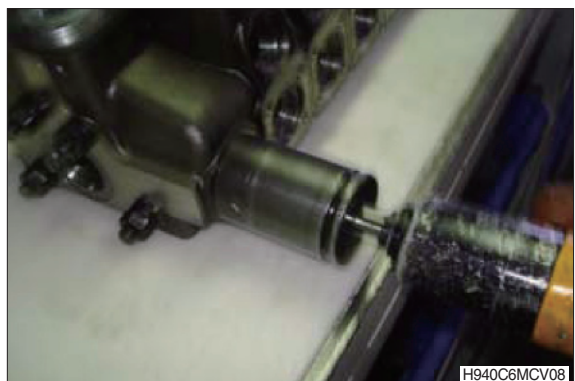

6) CHECK VALVE ASSEMBLY

- (1) Assemble the check valve kit into the check valve kit cavity and tighten it to 2.45 kgf · m (17.7 lbf · ft) torque (wrench 24) using pneumatic torque gun.



7) ER2 VALVE ASSEMBLY

- (1) Assemble the electrical R2 kit into the ER2 kit cavity and tighten it to 2.45 kgf · m (17.7 lbf · ft) torque (Wrench 24) using pneumatic torque gun (make sure that O-ring is present in the kit).



- (2) Insert the coil into the solenoid.
- (3) Assemble the lock nut and tighten with allen key.

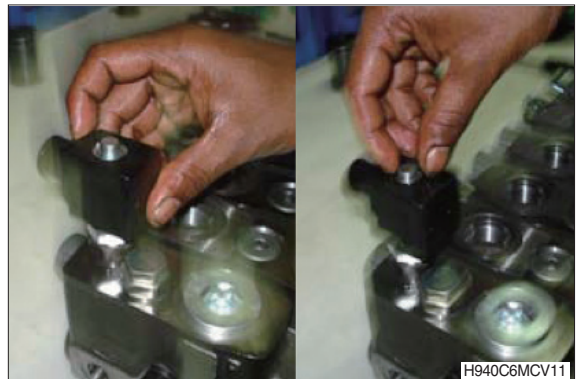

8) PORT RELIEF VALVE ASSEMBLY

(1) Assemble the port relief valve into the port relief valve cavity as describe below and tighten it to 2.45 kgf · m (17.7 lbf · ft) torque (wrench 19) using pneumatic torque gun.

- 1st section (from inlet) : ZTAL-00275
- 2nd section (dipper) : ZTAL-00276
- 5th section (boom) : ZTAL-00276
- 6th section (bucket) : ZTAL-00276

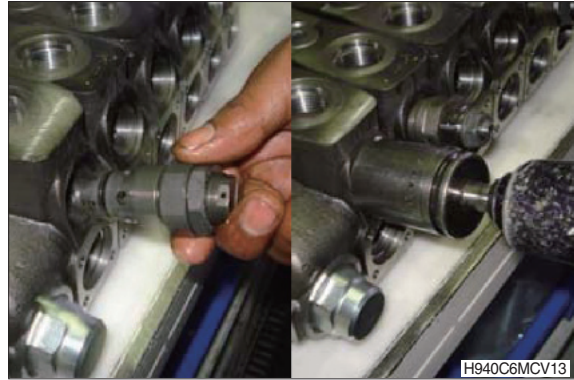

9) PORT RELIEF VALVE CAVITY PLUG ASSEMBLY

(1) Plug remaining port relief cavities with P3T plugs (i.e. on A3, B3, A4 & B4 port) and tighten it to 4.28 kgf · m (31 lbf · ft) torque (wrench 12) using pneumatic torque gun.

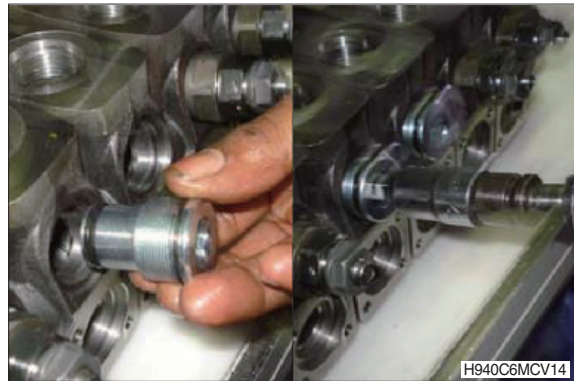

10) SPOOL ASSEMBLY

(1) Lubricate all the spool cavities with hyspin VG46.

(2) Insert spool as describe below with eye end of the spool is on the F kit side.

- 1st section : ZTAL-00265 (1TX spool)
- 2nd section to 6th section :
ZTAL-00266/00264 (normal spool)

(3) Move the spools in and out two to three times for free movement.

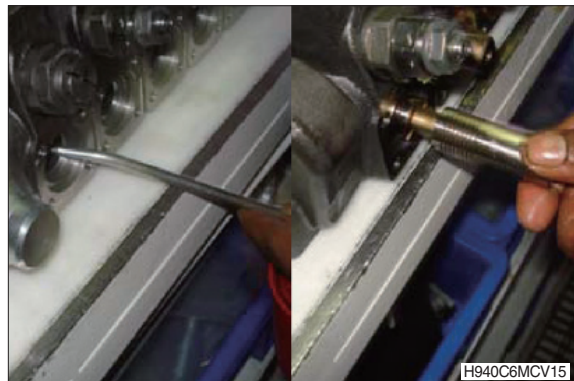

11) O-RING AND SPACER ASSEMBLY ON CONTROL KIT SIDE

- (1) Assemble the O-ring in the O-ring groove as shown in the picture.
- (2) Assemble the spacer into the spacer groove provided in spool cavity (chamfered face should go inside the cavity).

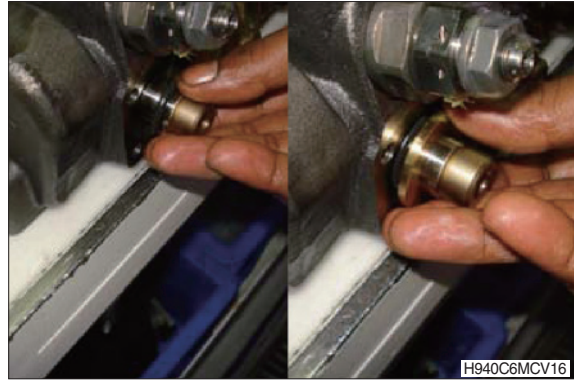

12) CONTROL KIT ASSEMBLY ON BOTH SIDE OF THE VALVE

- (1) Apply a drop of loctite #270 thread locker on control kit screw threads.
- (2) Place control kit spring in between two bushes as shown, and then assemble these into the spool with control kit screw.



- (3) Tighten the control kit to 0.99 kgf · m (7.16 lbf · ft) torque (wrench 05) using pneumatic torque gun.
- (4) Lubricate the proper quantity of grease to all control kits.



- (5) Assemble the end cap with M6 screws and tighten to 0.67 kgf · m (4.85 lbf · ft) torque using pneumatic torque gun.



13) LEVER KIT ASSEMBLY

- (1) Assemble the O-ring in the O-ring groove as shown in the picture.
- (2) Assemble the spacer into the spacer groove provided in spool cavity (chamfered face should go inside the cavity)

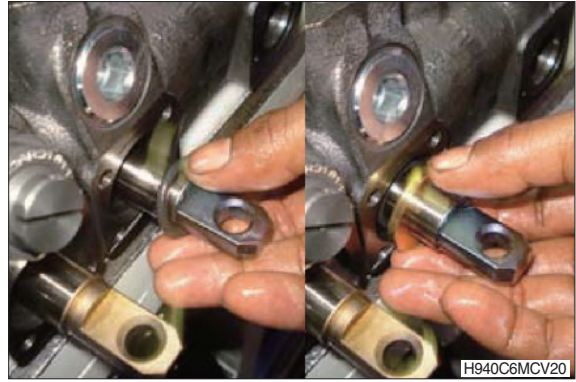

- (3) Assemble lever cap and tighten it with M5 screws to 0.99 kgf · m (7.16 lbf · ft) torque using pneumatic torque gun.



14) COMPLETE VALVE ASSEMBLY



4. RCV LEVER

1) STRUCTURE

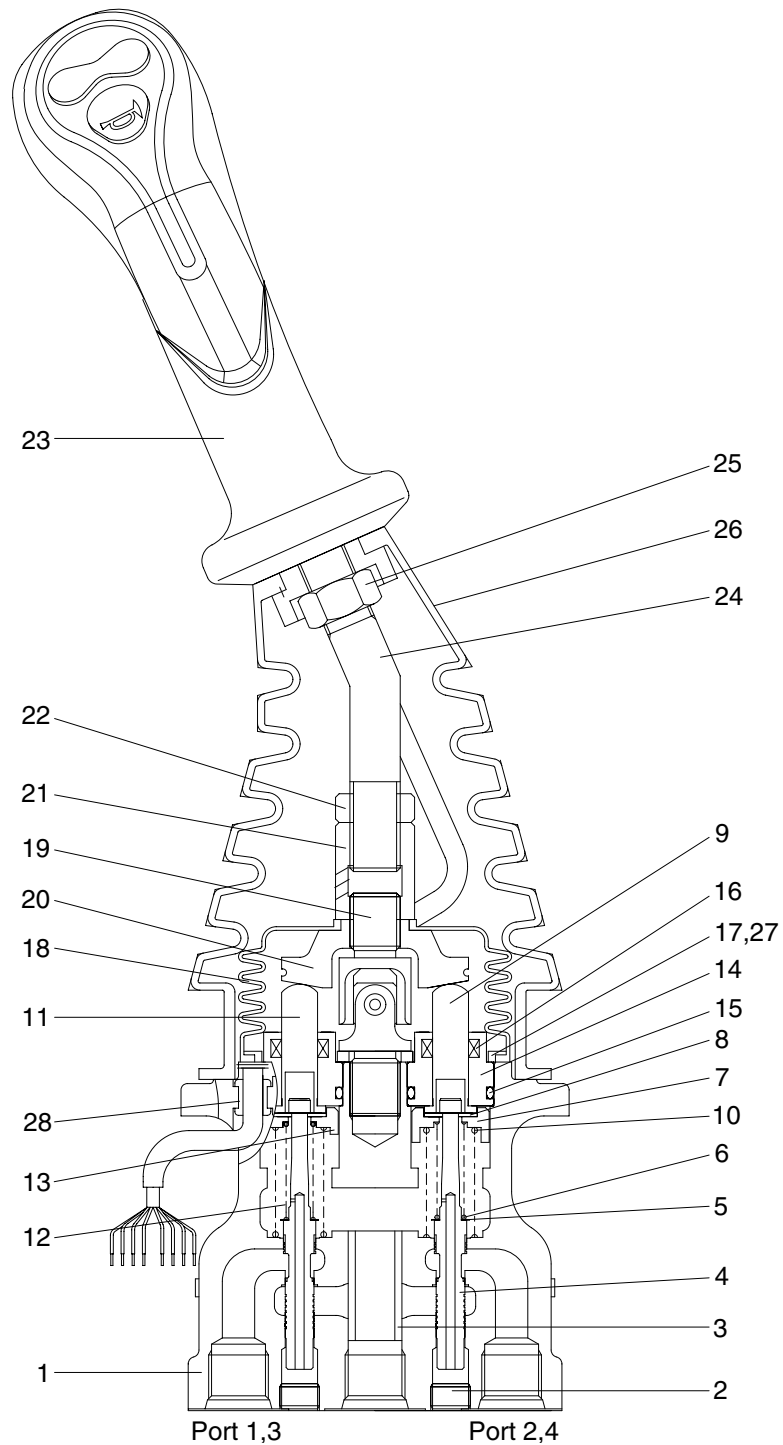

H940C6WE71

1	Case	8	Stopper	15	O-ring	22	Lock nut
2	Plug	9	Push rod	16	Rod seal	23	Handle assembly
3	Bushing	10	Spring	17	Plate	24	Handle bar
4	Spool	11	Push rod	18	Boot	25	Nut
5	Shim	12	Spring	19	Joint assembly	26	Boot
6	Spring seat	13	Spring seat	20	Swash plate	27	Spring pin
7	Spring seat	14	Plug	21	Adjusting nut	28	Bushing

2) TOOLS AND TIGHTENING TORQUE

(1) Tools

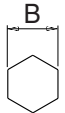
Tool name	Remark	
Allen wrench	6	
Spanner	22	
	27	
(+) Driver	Length 150	
(-) Driver	Width 4~5	
Torque wrench	Capable of tightening with the specified torques	

(2) Tightening torque

Part name	Item	Size	Torque	
			kgf · m	lbf · ft
Plug	2	PT 1/8	3.0	21.7
Joint	19	M14	3.5	25.3
Swash plate	20	M14	5.0±0.35	36.2±2.5
Adjusting nut	21	M14	5.0±0.35	36.2±2.5
Lock nut	22	M14	5.0±0.35	36.2±2.5

3) DISASSEMBLY

- (1) Clean pilot valve with kerosene.
 - ※ Put blind plugs into all ports
- (2) Fix pilot valve in a vise with copper (or lead) sheets.
- (3) Remove end of boot (26) from case (1) and take it out upwards.

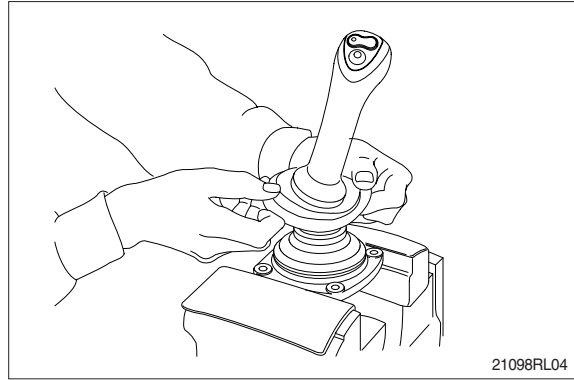

- ※ For valve with switch, remove cord also through hole of casing.

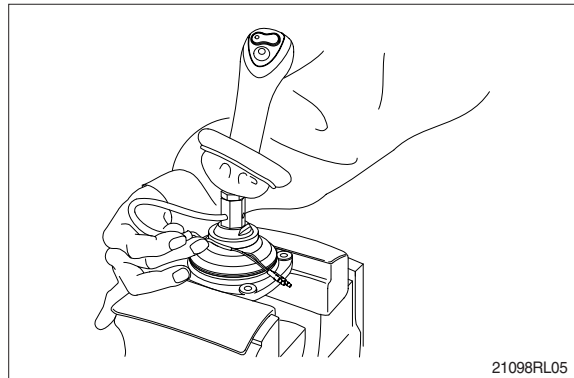

- (4) Loosen lock nut (22) and adjusting nut (21) with spanners on them respectively, and take out handle section as one body.

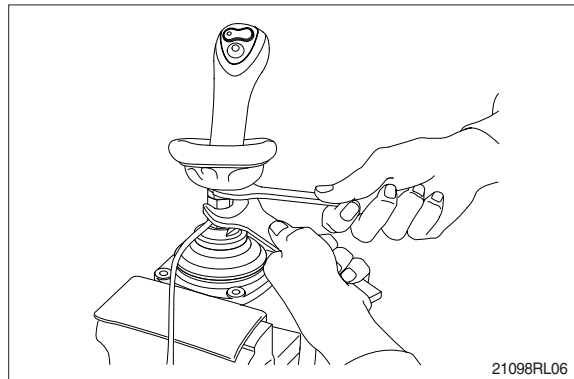

- (5) Remove the boot (18).

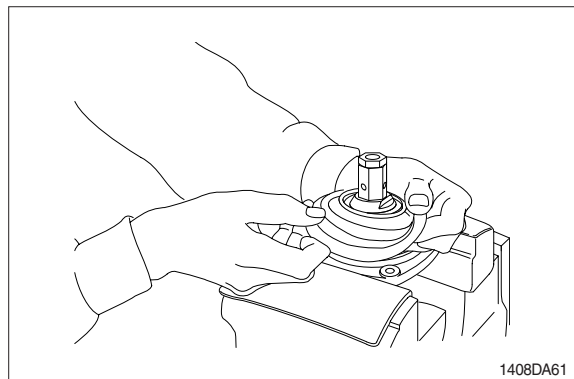

- (6) Loosen adjusting nut (21) and swash plate (20) with spanners on them respectively, and remove them.

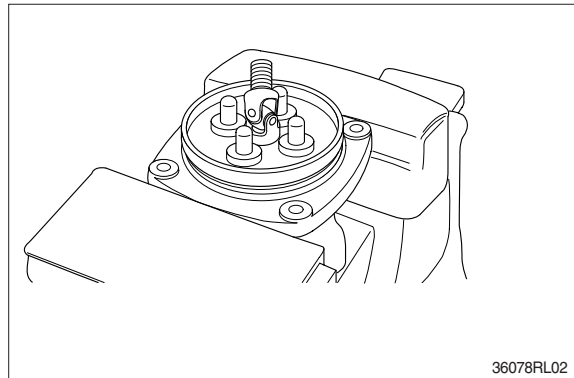
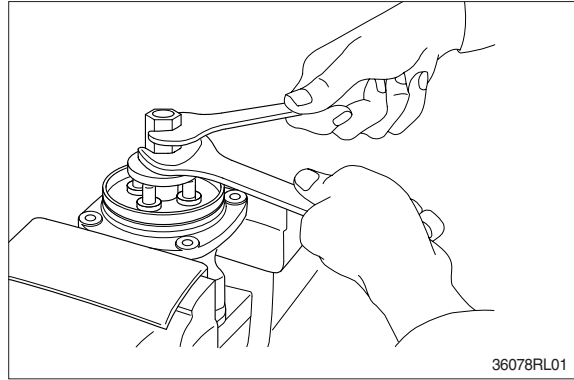

- (7) Turn joint anticlockwise to loosen it, utilizing jig (Special tool).

※ When return spring (10) is strong in force, plate (17), plug (14) and push rod (11) will come up on loosening joint. Pay attention to this.

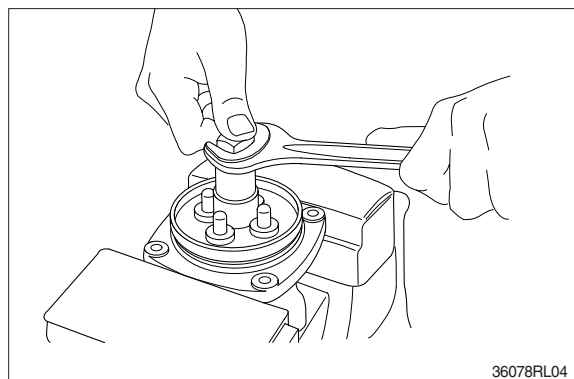
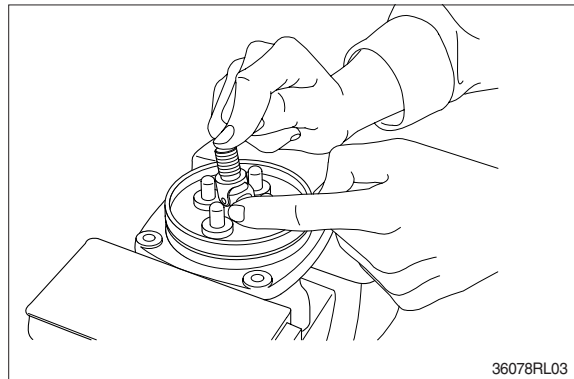

(8) Remove plate (17).

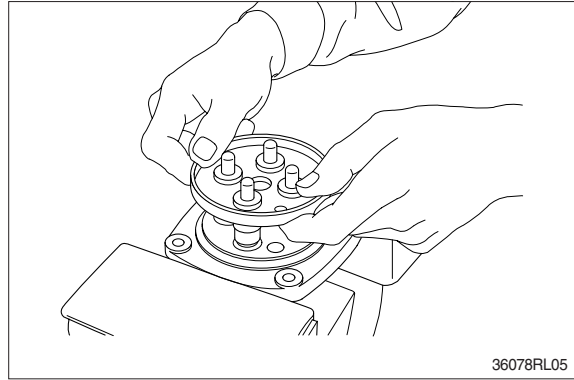

(9) When return spring (10) is weak in force, plug (14) stays in casing because of sliding resistance of O-ring.

- ※ Take it out with minus screwdriver. Take it out, utilizing external periphery groove of plug and paying attention not to damage it by partial loading.
- ※ During taking out, plug may jump up due to return spring (10) force. Pay attention to this.

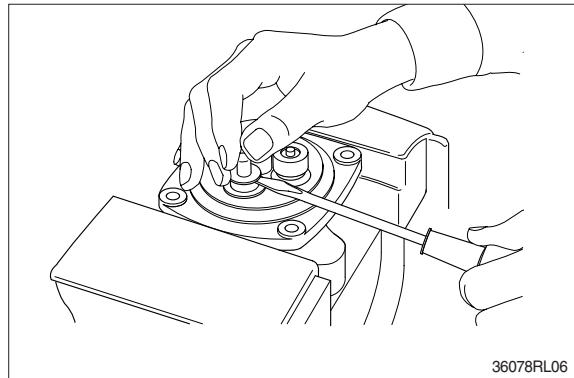

(10) Remove reducing valve subassembly and return spring (10) out of casing.

- ※ Record relative position of reducing valve subassembly and return springs.

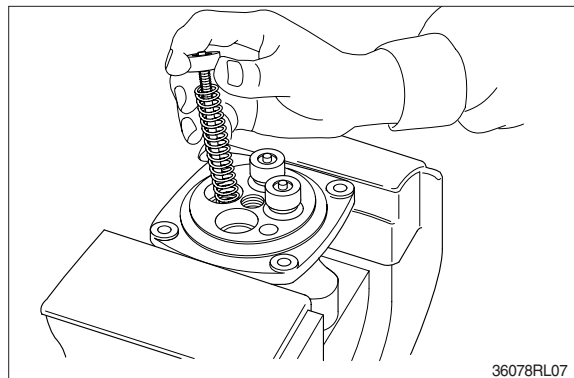

(11) Loosen hexagon socket head plug(2) with hexagon socket screw key.

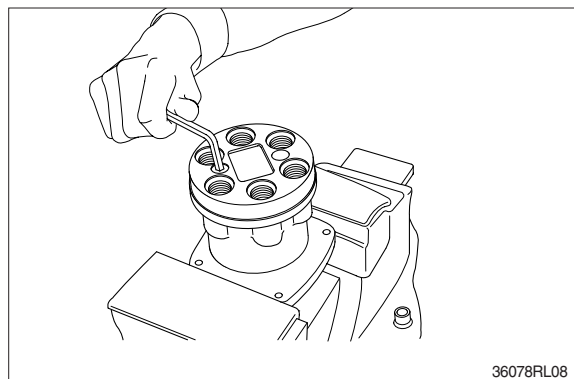

(12) For disassembling reducing valve section, stand it vertically with spool (4) bottom placed on flat workbench. Push down spring seat (7) and remove two pieces of semicircular stopper (8) with tip of small minus screwdriver.

- ※ Pay attention not to damage spool surface.
- ※ Record original position of spring seat (7).
- ※ Do not push down spring seat more than 6mm.

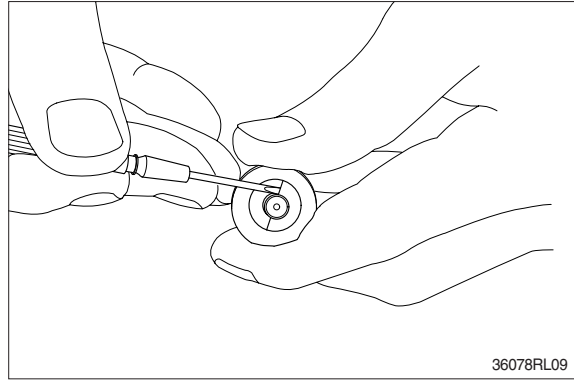

(13) Separate spool (4), spring seat (7), spring (6) and shim (5) individually.

- ※ Until being assembled, they should be handled as one subassembly group.

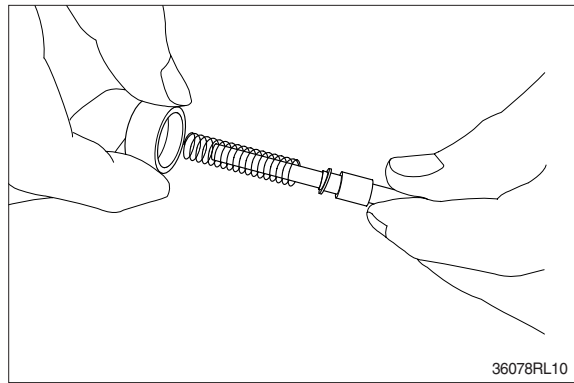

(14) Take push rod (11) out of plug (14).

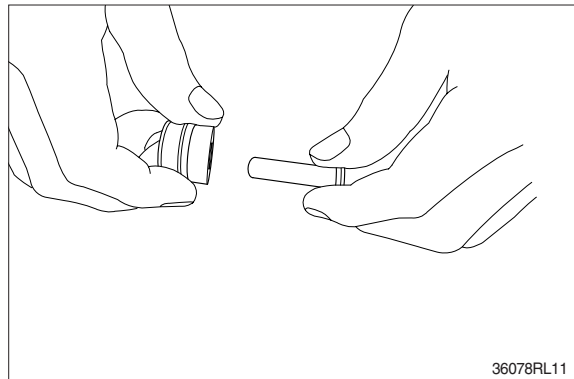

(15) Remove O-ring (15) and seal (16) from plug (14).

Use small minus screwdriver or so on to remove this seal.

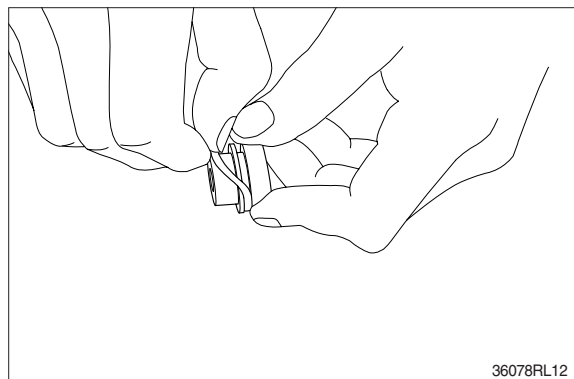

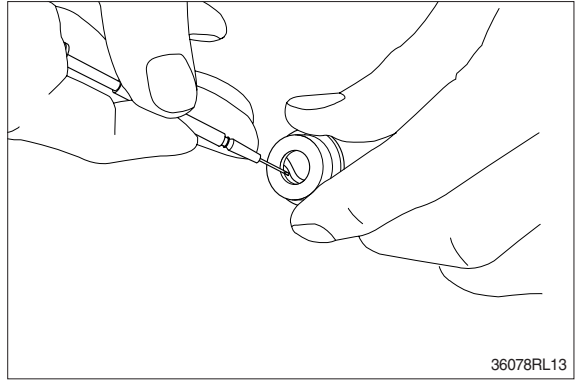

(16) Remove lock nut (22) and then boot (26).

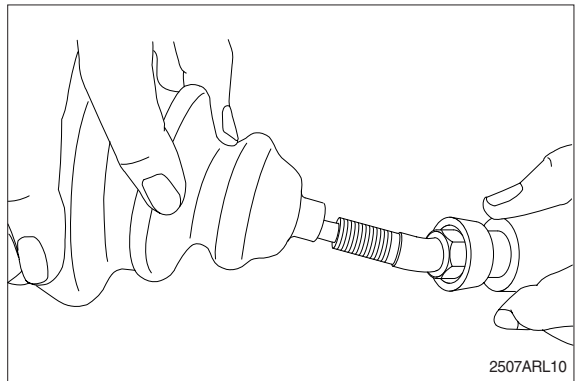
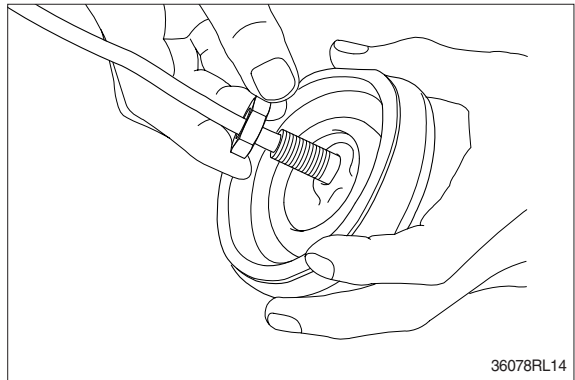

(16) Cleaning of parts

- ① Put all parts in rough cleaning vessel filled with kerosene and clean them (rough cleaning).
 - ※ If dirty part is cleaned with kerosene just after putting it in vessel, it may be damaged. Leave it in kerosene for a while to loosen dust and dirty oil.
 - ※ If this kerosene is polluted, parts will be damaged and functions of reassembled valve will be degraded.
Therefore, control cleanliness of kerosene fully.
- ② Put parts in final cleaning vessel filled with kerosene, turning it slowly to clean them even to their insides (finish cleaning).
 - ※ Do not dry parts with compressed air, since they will be damaged and/or rusted by dust and moisture in air.

(17) Rust prevention of parts

- Apply rust-preventives to all parts.
- ※ If left as they are after being cleaned, they will be rusted and will not display their functions fully after being reassembled.

4) ASSEMBLY

(1) Tighten hexagon socket head plug (2) to the specified torque.

※ Tighten two bolts alternately and slowly.

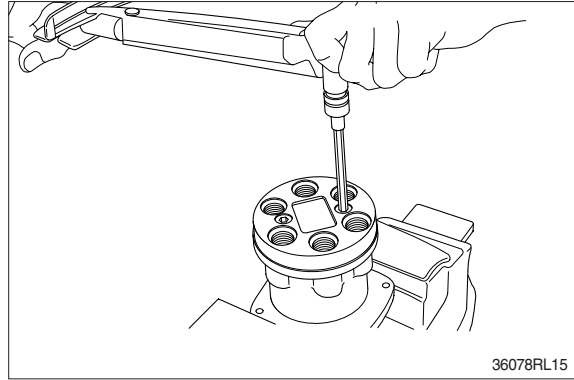

(2) Put shim (5), springs (6) and spring seat (7) onto spool (4) in this order.

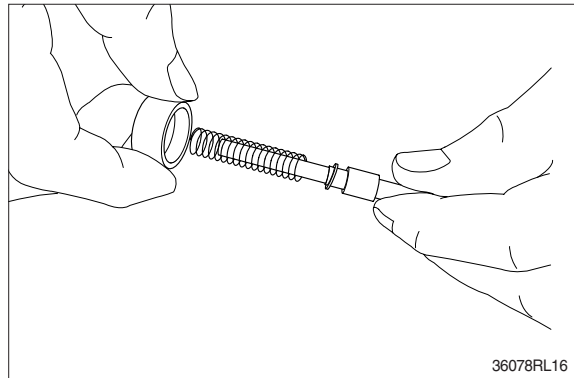

(3) Stand spool vertically with its bottom placed on flat workbench, and with spring seat pushed down, put two pieces of semicircular stopper (8) on spring seat without piling them on.

※ Assemble stopper (8) so that its sharp edge side will be caught by head of spool. Do not push down spring seat more than 6mm.

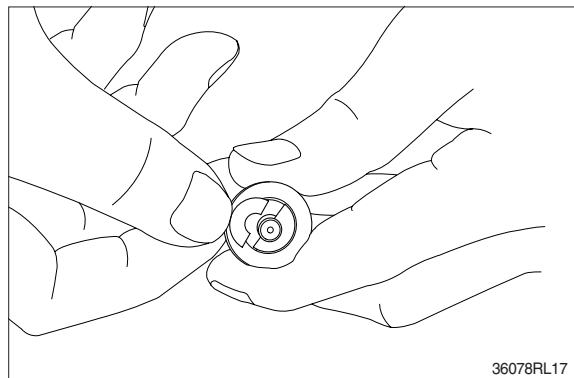

(4) Assemble spring (10) into casing (1). Assemble reducing valve subassembly into casing.

※ Assemble them to their original positions.

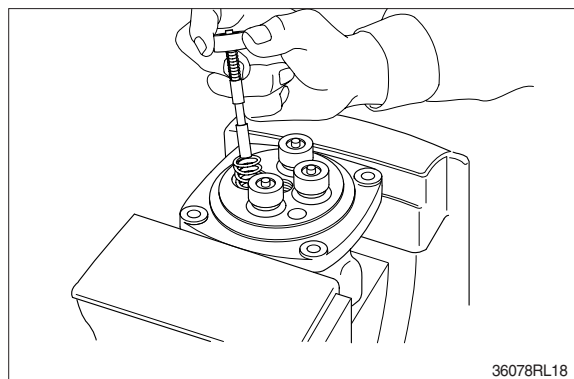

(5) Assemble O-ring (15) onto plug (14).

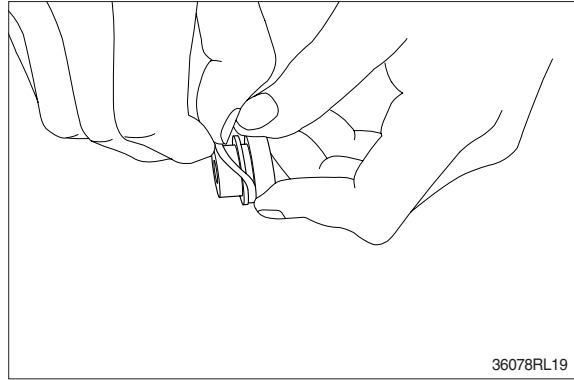

(6) Assemble seal (16) to plug (14).

※ Assemble seal in such lip direction as shown below.

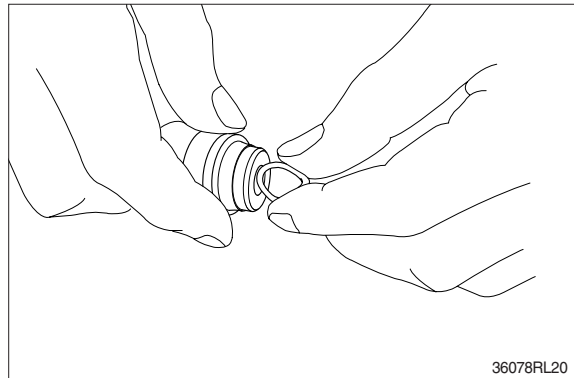

(7) Assemble push rod (11) to plug (14).

※ Apply working oil on push-rod surface.

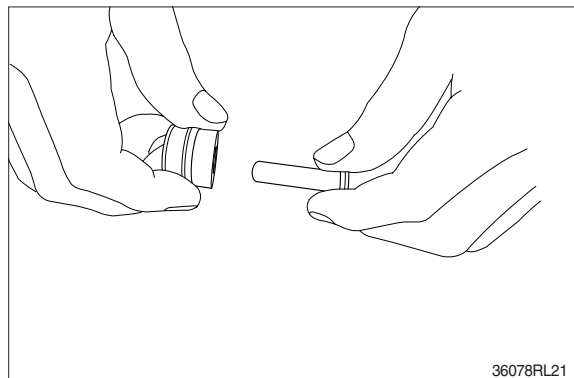

(8) Assemble plug subassembly to casing.

※ When return spring is weak in force, subassembly stops due to resistance of O-ring.

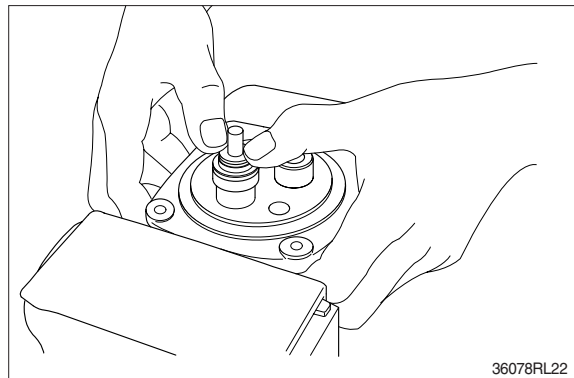

- (9) When return spring is strong in force, assemble 4 sets at the same time, utilizing plate (17), and tighten joint (19) temporarily.

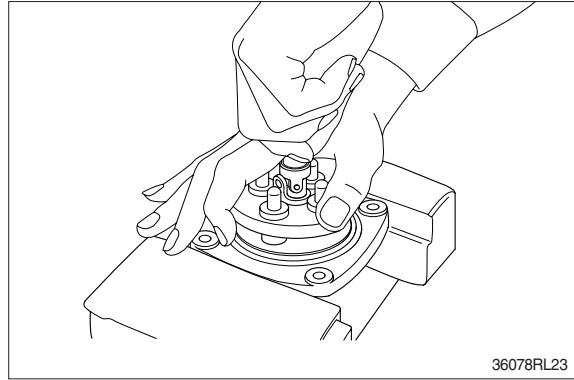

- (10) Fit plate (17).

- (11) Tighten joint (19) with the specified torque to casing, utilizing jig.

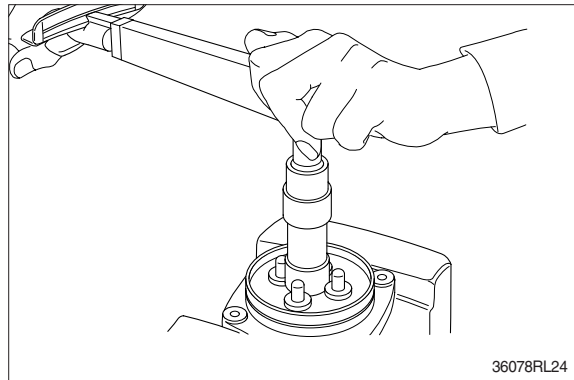

- (12) Assemble swash plate (20) to joint (19).
- ※ Screw it to position that it contacts with 4 push rods evenly.
 - ※ Do not screw it over.

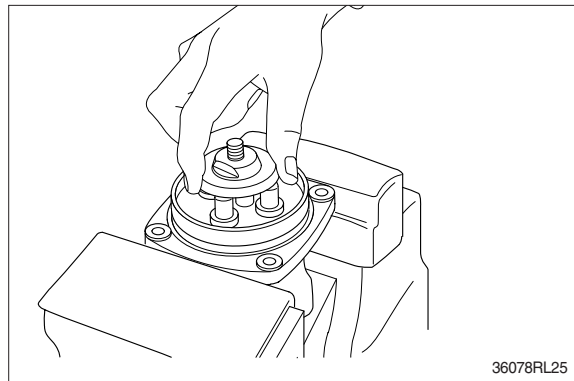

- (13) Assemble adjusting nut (21), apply spanner to width across flat of plate (20) to fix it, and tighten adjusting nut to the specified torque.
- ※ During tightening, do not change position of disk.

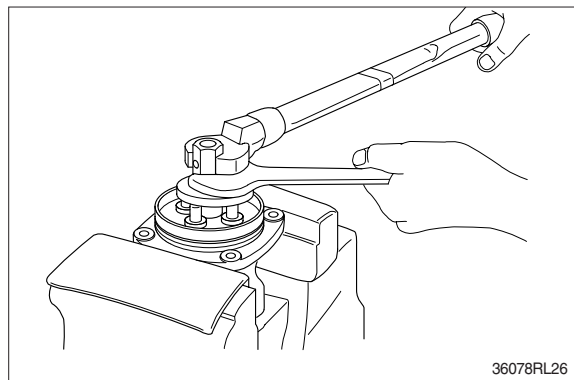

(14) Fit boot (18) to plate.

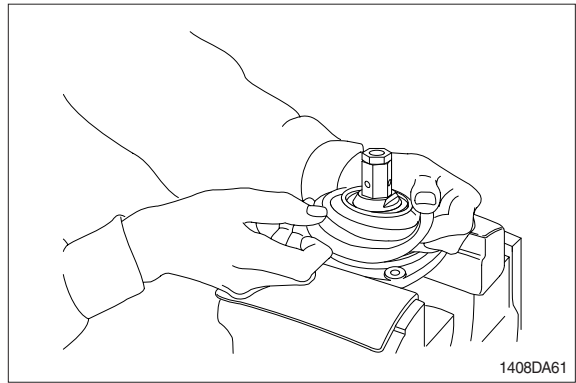

(15) Fit boot (26) and lock nut (22), and handle subassembly is assembled completely.

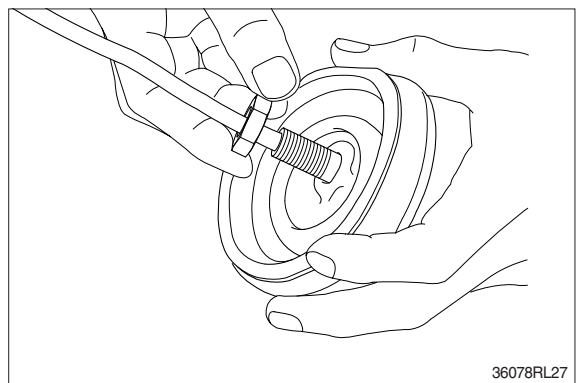
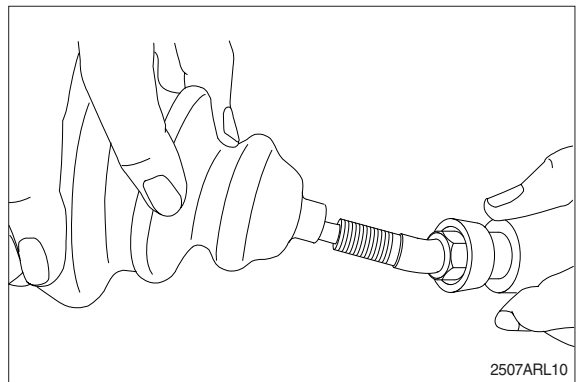

(16) Pull out cord and tube through adjusting nut hole provided in direction 60° to 120° from casing hole.

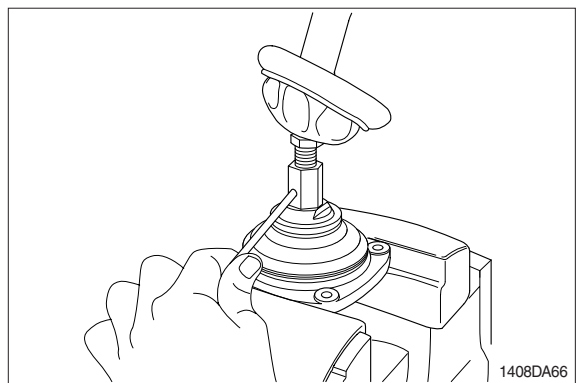

- (17) Assemble bushing (27) to plate and pass cord and tube through it.
※ Provide margin necessary to operation.

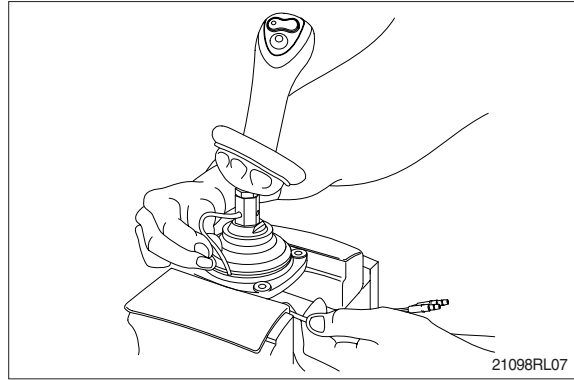

- (18) Determine handle direction, tighten lock nut (22) to specified torque to fix handle.

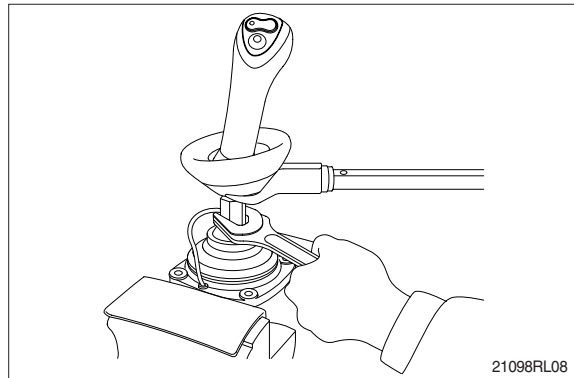

- (19) Apply grease to rotating section of joint and contacting faces of disk and push rod.

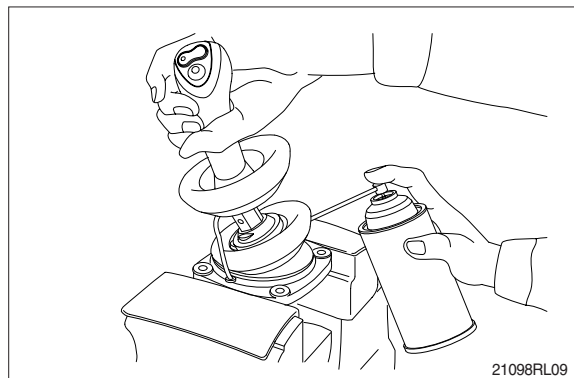

- (20) Assemble lower end of bellows to casing.
(21) Inject volatile rust-preventives through all ports and then put blind plugs in ports.

