

GROUP 2 SPECIFICATION

1. MAJOR COMPONENT

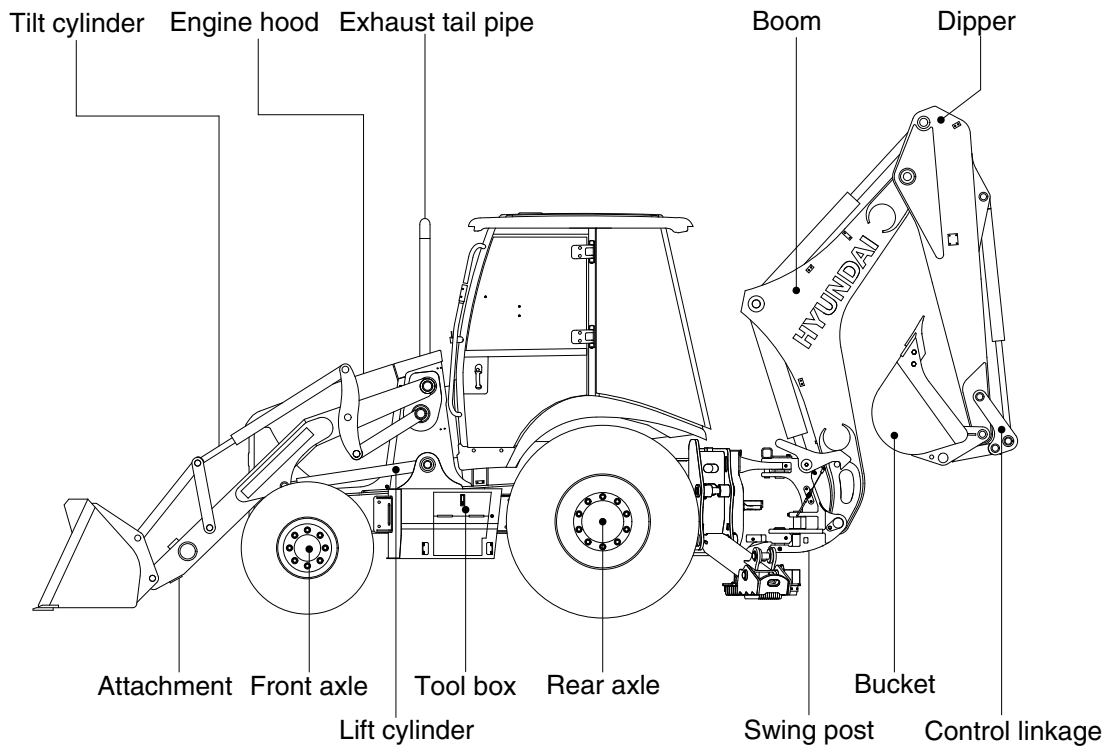
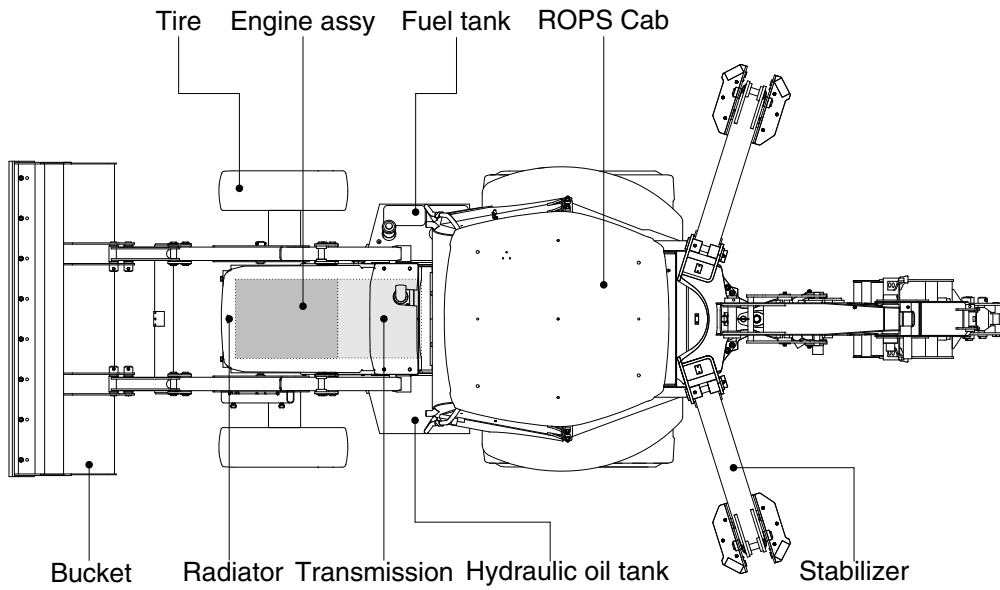

H930CB2SP01

2. SPECIFICATIONS

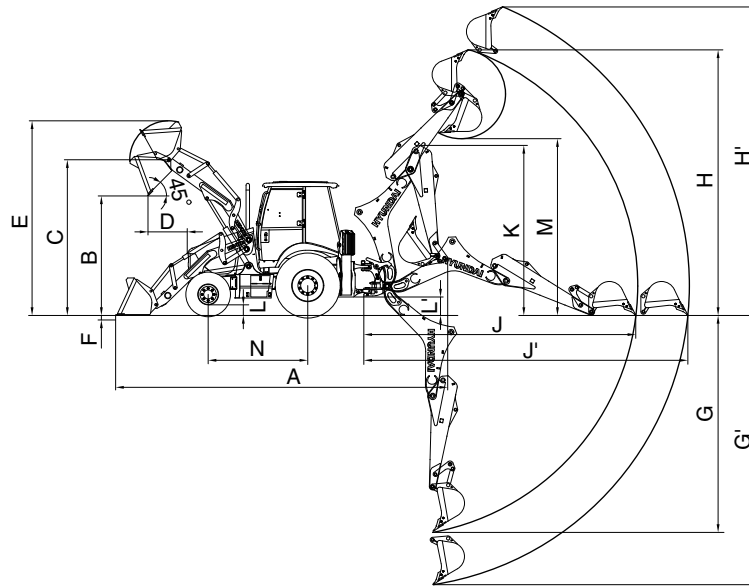

H940C2SP02

Description		Unit	Specification	
			H940CB	H930CB
Operating weight	Standard dipper and GP bucket	kg (lb)	7900 (17420)	7830 (17260)
	Extendible dipper and MP bucket	kg (lb)	8500 (18740)	8440 (18610)
Transport length	GP bucket		5800 (19' 0")	←
	MP bucket		5850 (19' 2")	←
Transport height	Standard dipper		3720 (12' 2")	←
	Extendible dipper		3720 (12' 2")	←
Transport width	GP bucket		2250 (7' 5")	←
	MP bucket		2350 (7' 9")	←
Loader data	Overall length	A	7240 (23' 9")	←
	Dump clearance	B	2710 (8' 11")	←
	Hinge pin height	C	3450 (11' 4")	←
	Dump reach	D	780 (2' 7")	←
	Max loading height	E	4230 (13' 11")	←
	Depth of bucket down	F	96 (3.8")	←
	Wheel base	N	2200 (7' 3")	←
Backhoe data	Max digging depth (STD)	G	4335 (14' 3")	4315 (14' 2")
	Max digging depth (EXT)	G'	5465 (17' 11")	5445 (17' 10")
	Max digging height (STD)	H	5520 (18' 1")	5565 (18' 3")
	Max digging height (EXT)	H'	6190 (20' 4")	6235 (20' 5")
	Max digging reach (STD)	J	5790 (19' 0")	5840 (19' 2")
	Max digging reach (EXT)	J'	6815 (22' 4")	6865 (22' 6")
	Max loading height	K	3695 (12' 1")	←
	Minimum ground clearance	L	350 (1' 2")	←
	Height of outrigger	L'	265 (10.4")	←
	Dumping height	M	3735 (12' 3")	3690 (12' 1")

3. SPECIFICATION FOR MAJOR COMPONENTS

1) ENGINE

Item	Specification	
	H940CB	H930CB
Manufacture	PERKINS	
Model	1104C-44T	
Type	4-stroke, turbocharged	
Non-road emission standards	Certified to EPA Tier 2 / EU stage II	
Piston displacement	4.4 l (1.2 U.S.gal)	
Fuel	Diesel	
Rated horse power (Gross)	100 hp (74.5 kW) at 2200 rpm	92 hp (68.5 kW) at 2200 rpm
Maximum torque at 1350 rpm	42 kgf · m (301 lbf · ft)	40 kgf · m (291 lbf · ft)
Alternator	100 amp	
Battery	12V	

2) MAIN PUMP

Item		Specification	
		H940CB	H930CB
Type		Fixed displacement double gear pump	
Capacity	Steering	31 cc/rev	31 cc/rev
	Attachment	35 cc/rev	31 cc/rev
Maximum operating pressure		250 kgf/cm ² (3560 psi)	
Rated oil quantity	Steering	68 l /min (18.0 U.S.gpm)	68 l /min (18.0 U.S.gpm)
	Attachment	77 l /min (20.3 U.S.gpm)	68 l /min (18.0 U.S.gpm)
Rated speed		2200 rpm	

3) MAIN CONTROL VALVE FOR LOADER

Item		Specification
Type		2 spool (option : 3 spool)
Operating method		Manual control
Main relief valve pressure		250 kgf/cm ² (3560 psi)
Unloading relief valve pressure		220 kgf/cm ² (3130 psi)
Overload relief valve pressure	Bucket out	175 kgf/cm ² (2490 psi)
	Bucket in	300 kgf/cm ² (4270 psi)

4) MAIN CONTROL VALVE FOR BACKHOE

Item	Unit	Specification
Type	-	6 spool (option : 7 spool)
Operating method	-	Hydraulic pilot control & Manual control
Main relief valve pressure	kgf/cm ² (psi)	250 (3560)
Overload relief valve pressure	Boom up	kgf/cm ² (psi) 280 (3980)
	Boom down	kgf/cm ² (psi) 280 (3980)
	Swing LH, RH	kgf/cm ² (psi) 250 (3560)
	Bucket in	kgf/cm ² (psi) 280 (3980)
	Bucket out	kgf/cm ² (psi) 280 (3980)
	Dipper in	kgf/cm ² (psi) 280 (3980)
	Dipper out	kgf/cm ² (psi) 280 (3980)

5) STEERING UNIT

Item	Unit	Specification		
Type	-	Dynamic load sensing, non load reaction		
		Emergency 4WD	2WD	4WD
Displacement	cc/rev	156 + 59	160	160
Relief valve pressure	kgf/cm ² (psi)	248 (3530)	175 (2490)	210 (2990)
Overload relief valve pressure	kgf/cm ² (psi)	303 (4310)	235 (3340)	265 (3770)

6) PILOT SUPPLY UNIT (option)

Item	Unit	Specification
Reducing & relief valve pressure	kgf/cm ² (psi)	30 (430)
Safety solenoid valve	Voltage	DC 12V
	Ampere	1.8 A

7) ACCUMULATOR (option)

Item	Unit	Specification	
		Ride control	Pilot supply
Type	-	Nitrogen	
Capacity	ℓ	1.5	0.35
Precharge pressure	kgf/cm ² (psi)	30 (430)	15 (215)
Max working pressure	kgf/cm ² (psi)	350 (4980)	170 (2420)

8) REMOTE CONTROL VALVE (option)

Item	Unit	Specification			
		For backhoe	For stabilizer	For loader	
Type	-	Pressure reducing type			
Operating	Minimum	kgf/cm ² (psi)	4 (57)	5.5 (78)	5 (70)
	Maximum	kgf/cm ² (psi)	26 (370)	16.5 (235)	16.5 (235)
Single operation angle	degree	19	23.5	16.5	

9) LINE FILTER (option)

Item	Unit	Specification
Filtration rating	μ m	10
Max working pressure	kgf/cm ² (psi)	280 (3980)
Bypass cracking pressure	kgf/cm ² (psi)	7 (100)

10) DOUBLE PILOT CHECK VALVE FOR STABILIZER

Item	Unit	Specification
Max working pressure	kgf/cm ² (psi)	350 (4980)
Cracking pressure	kgf/cm ² (psi)	3 (43)
Pilot ratio	-	1 : 4.5

11) TIRES

Item	Unit	Specification
Front	2WD	11L-16 (standard)
	4WD	12.5/80-18 (option)
Rear	-	19.5L-24 (standard)
	-	16.9-28 (option)
	-	21L-24 (option)

12) POWERTRAIN

Item		Specification			
Transmission		4-Speed helical-cut gears, full powershift with hydraulic control standard, electric clutch cutoff on loader lever			
Maximum travel speed with standard (19.5L-24 tire)		() : option			
H930CB	Gear	1st	2nd	3rd	4th
	Forward (km/hr)	5.3	9.7	19.6	34.5
	Reverse (km/hr)	6.7	12.2	(19.3)	N/A
H940CB	Gear	1st	2nd	3rd	4th
	Forward (km/hr)	5.2	9.6	19.4	34.0
	Reverse (km/hr)	6.6	12.0	(19.1)	N/A
Torque converter (ratio)		1 : 2.53			
Differential lock		Front : Conventional Rear : Hydraulic lock (push-button activation)			
Steering		Hydrostatic power and emergency steering			
Brake	Service	Hydraulic wet disc, mounted inboard, self-adjusting and self-equalizing			
	Parking	Spring applied, hydraulically releases, wet, multi disc independent of service brakes with electric switch control			

13) BUCKET

Item		Capacity (liters)	Width (mm)	Weight (kg)
Loader	GP	800	2250	385
	MP	1000	2350	730
Backhoe	H930CB	170	630	131
	H940CB	200	610	156

14) RECOMMENDED LUBRICANTS

Use only oils listed below or equivalent.

Do not mix different brand oil.

Service point	Kind of fluid	Capacity ℓ (U.S. gal)	Ambient temperature °C (°F)									
			-50 (-58)	-30 (-22)	-20 (-4)	-10 (14)	0 (32)	10 (50)	20 (68)	30 (86)	40 (104)	
Engine oil pan	Engine oil	8 (2.1)	★ ¹ SAE 5W-40					SAE 30				
			SAE 10W				SAE 10W-30					
			SAE 15W-40									
			SAE 10W-30									
			SAE 15W-40									
Transmission	Engine oil	18 (4.6)	SAE 10W-30									
			SAE 15W-40									
Axle	UTTO	Front (4WD): 8 (2.1)	★Refer to below list									
		Rear : 16 (4.2)										
Hydraulic tank	Hydraulic oil	Tank: 60 (15.9)	★ ¹ ISO VG 15									
		System: 93 (24.6)	ISO VG 46			ISO VG 68						
Fuel tank	Diesel fuel	127 (33.5)	★ ¹ ASTM D975 NO.1				ASTM D975 NO.2					
Fitting (grease nipple)	Grease	As required	★ ¹ NLGI NO.1					NLGI NO.2				
Radiator (reservoir tank)	Mixture of antifreeze and soft water★ ²	20 (5.3)	Ethylene glycol base permanent type (50 : 50)									
			★ ¹ Ethylene glycol base permanent type (60 : 40)									

· SAE : Society of Automotive Engineers

· API : American Petroleum Institute

· ISO : International Organization for Standardization

· NLGI : National Lubricating Grease Institute

· ASTM : American Society of Testing and Material

· UTTO : Universal Tractor Transmission Oil

★ Recommended oil list

- BP TERRAC SUPER TRANSMISSION 10W-30

- CASTROL AGRI TRANS PLUS 10W-30

- MOBILFLUID 426

- SHELL DONAX TD 10W-30

- TOTAL DYNATRANS MPV

★¹ Cold region

★² Soft water

City water or distilled water