

## SECTION 7 ELECTRICAL SYSTEM

Group 1 Component Location .....	7-1
Group 2 Electrical Circuit .....	7-3
Group 3 Monitoring System .....	7-26
Group 4 Switches .....	7-31
Group 5 Electrical Component Specification .....	7-40
Group 6 Connectors .....	7-46

# SECTION 7 ELECTRICAL SYSTEM

## GROUP 1 COMPONENT LOCATION

### 1. LOCATION 1

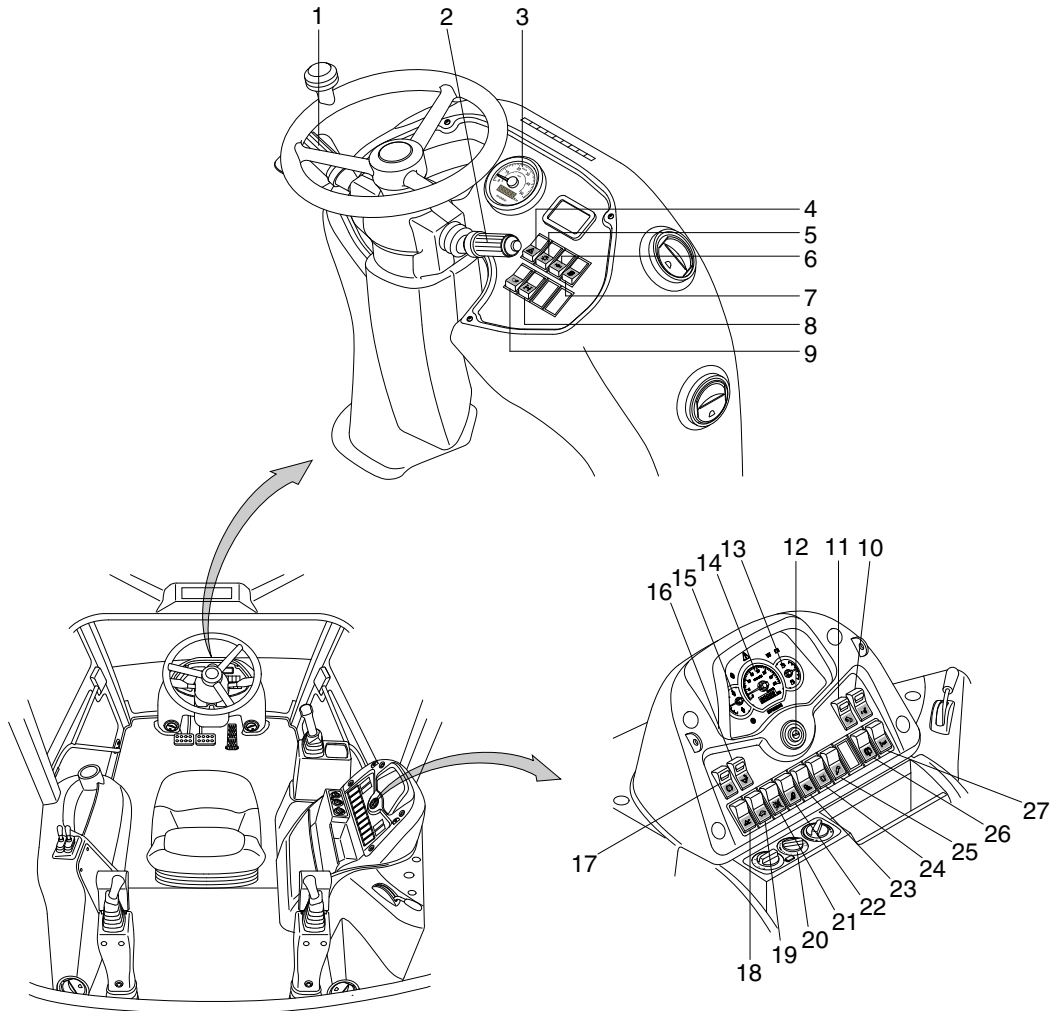

H930CB7EL80

- |                               |  |                                    |
|-------------------------------|--|------------------------------------|
| 1 Gear selector               | 10 Control pattern change switch (opt) | 19 Low speed control switch        |
| 2 Multi-function switch       | 11 Safety switch (backhoe)             | 20 Air conditioner & heater switch |
| 3 Speed meter                 | 12 Starting switch                     | 21 Buzzer stop switch              |
| 4 Hazard warning switch       | 13 Fuel level gauge                    | 22 Front work lights switch        |
| 5 Side and head light switch  | 14 RPM gauge                           | 23 Rear work lights switch         |
| 6 Differential lock switch    | 15 Coolant temp gauge                  | 24 Beacon switch                   |
| 7 Fuel warmer switch          | 16 Safety switch (loader)              | 25 Breaker switch                  |
| 8 4 Wheel drive select switch | 17 Parking brake switch                | 26 Rear window wiper switch        |
| 9 Ride control switch         | 18 Return to dig switch                | 27 Boom lock switch                |

## 2. LOCATION 2

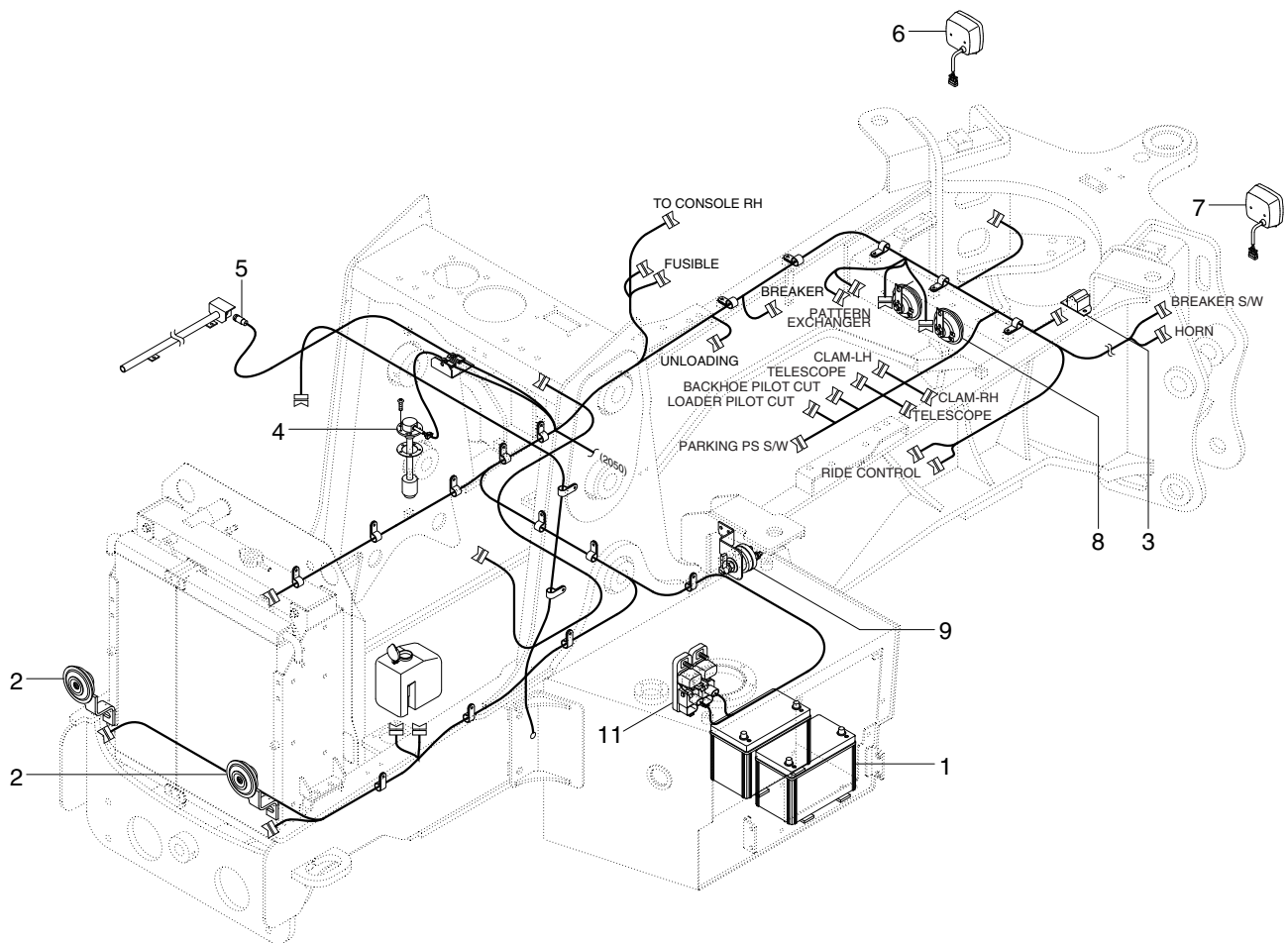

H930CB7EL81

- |   |             |   |                       |    |               |
|---|-------------|---|-----------------------|----|---------------|
| 1 | Battery     | 5 | Proximity switch      | 9  | Master switch |
| 2 | Horn        | 6 | Combination lamp - LH | 11 | Power relay   |
| 3 | Back buzzer | 7 | Combination lamp - RH |    |               |
| 4 | Fuel sender | 8 | Hone                  |    |               |