

## SECTION 5 TROUBLESHOOTING

Group 1 Before Troubleshooting .....	5-1
Group 2 Hydraulic and Mechanical System .....	5-4
Group 3 Electrical System .....	5-24
Group 4 Air conditioner and Heater System .....	5-39

## GROUP 1 BEFORE TROUBLESHOOTING

### 1. INTRODUCTION

When a trouble is occurred in the machine, this section will help an operator to maintain the machine with easy.

The trouble of machine is parted Hydraulic & Mechanical system, and Air conditioner and heater system.

At each system part, an operator can check the machine according to the troubleshooting process diagram.

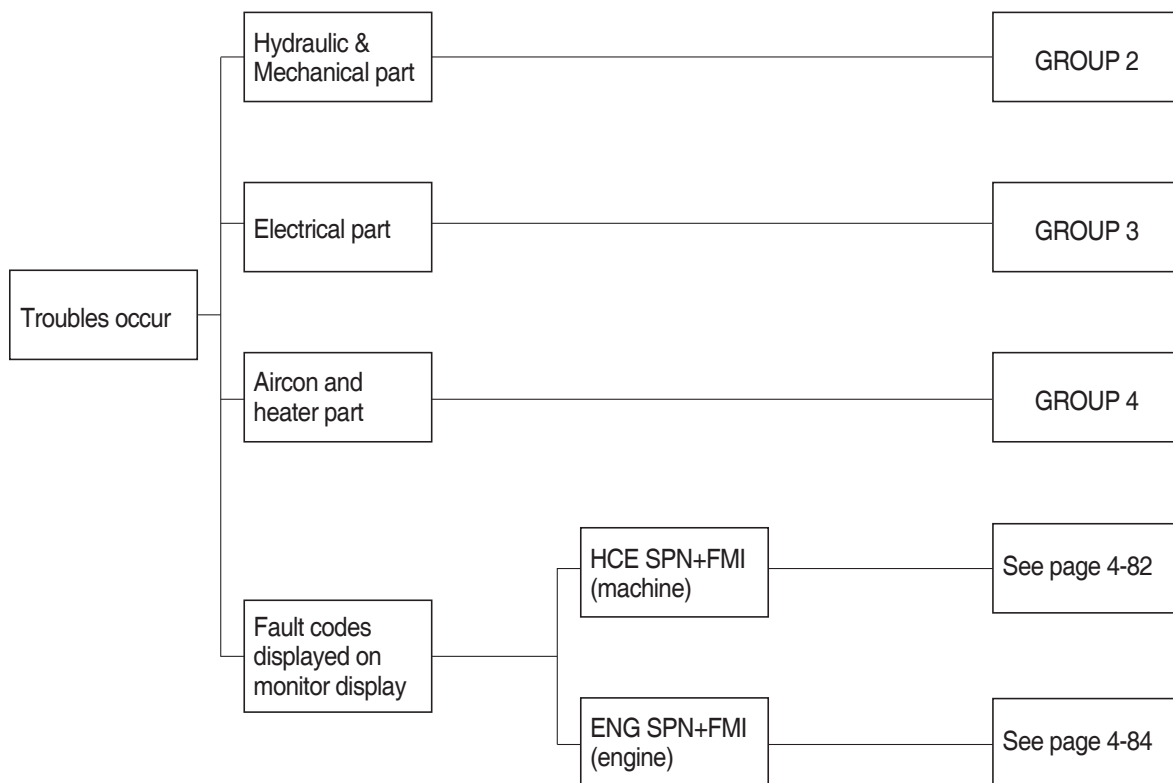

## 2. DIAGNOSING PROCEDURE

To carry out troubleshooting efficiently, the following steps must be observed.

### STEP 1. Study the machine system

Study and know how the machine is operating, how the system is composing, what kinds of function are installed in the machine and what are specifications of the system components by the machine service manual.

Especially, deepen the knowledge for the related parts of the trouble.

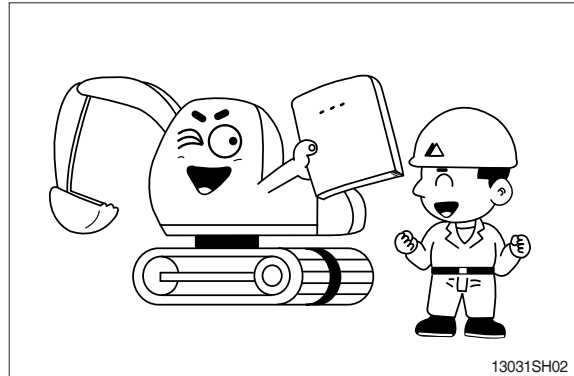

### STEP 2. Ask the operator

Before inspecting, get the full story of malfunctions from a witness --- the operator.

- 1) How the machine is used and when it is serviced?
- 2) When the trouble was noticed and what work the machine was doing at that time?
- 3) What is the phenomenon of the trouble?  
Was the trouble getting worse, or did it come out suddenly for the first time?
- 4) Did the machine have any troubles previously? If so, which parts were repaired before.

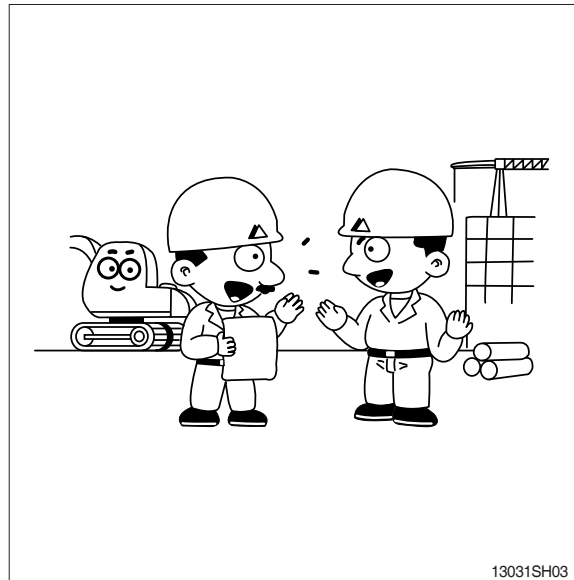

### STEP 3. Inspect the machine

Before starting troubleshooting, check the machine for the daily maintenance points as shown in the operator's manual.

And also check the electrical system including batteries, as the troubles in the electrical system such as low battery voltage, loose connections and blown out fuses will result in malfunction of the controllers causing total operational failures of the machine.

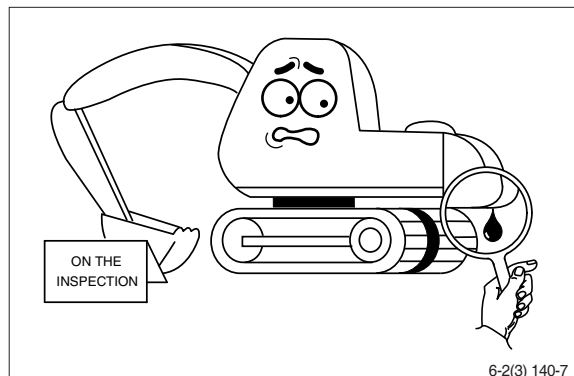

#### STEP 4. Inspect the trouble actually on the machine

In case that some trouble cannot be confirmed, obtain the details of the malfunction from the operator.

Also, check if there are any incomplete connections of the wire harnesses or not.

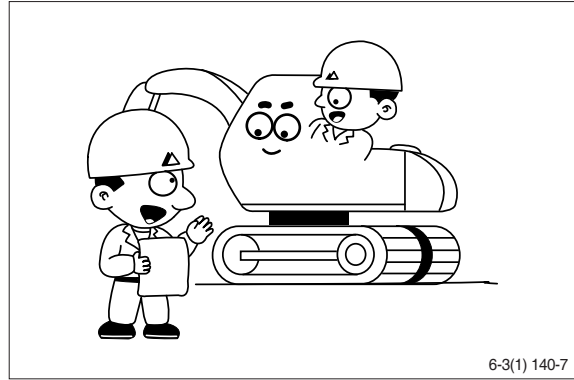

#### STEP 5. Perform troubleshooting

According to where the trouble parts are located, hydraulic & mechanical system part or electrical system part or mechatronics system part, perform troubleshooting the machine refer to the each system part's troubleshooting process diagram.

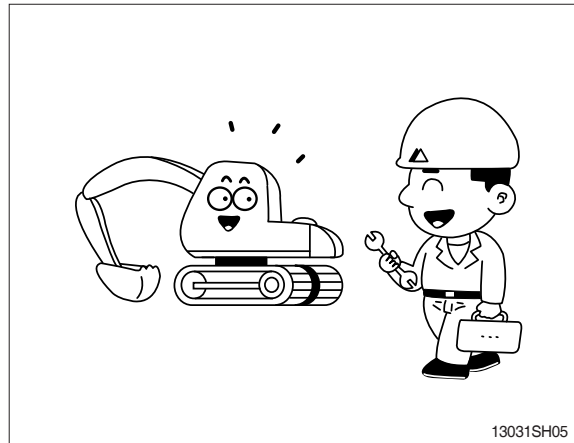

#### STEP 6. Trace a cause

Before reaching a conclusion, check the most susceptible causes again. Try to trace what the real cause of the trouble is.

Make a plan of the appropriate repairing procedure to avoid consequential malfunctions.

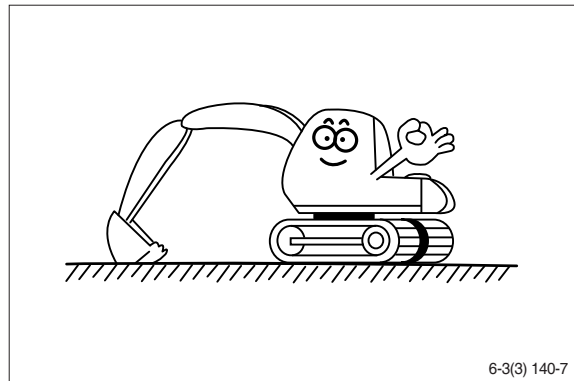

## GROUP 2 HYDRAULIC AND MECHANICAL SYSTEM

### 1. INTRODUCTION

#### 1) MACHINE IN GENERAL

- (1) If even a minor fault is left intact and operation is continued, a fatal failure may be caused, entailing a large sum of expenses and long hours of restoration.  
Therefore when even a small trouble occurs, do not rely on your intuition and experience, but look for the cause based on the troubleshooting principle and perform maintenance and adjustment to prevent major failure from occurring. Keep in mind that a fault results from a combination of different causes.
- (2) The following lists up commonly occurring faults and possible causes with this machine. For the troubleshooting of the engine, refer to the coming troubleshooting and repair.
- (3) When carrying out troubleshooting, do not hurry to disassemble the components.  
It will become impossible to find the cause of the problem.
- (4) Ask user or operator the following.
  - ① Was there any strange thing about machine before failure occurred?
  - ② Under what conditions did the failure occur?
  - ③ Have any repairs been carried out before the failure?
- (5) Check before troubleshooting.
  - ① Check oil and fuel level.
  - ② Check for any external leakage of oil from components.
  - ③ Check for loose or damage of wiring and connections.

## 2. DRIVE SYSTEM

### 1) UNUSUAL NOISE COMES OUT OF PUMP CONNECTION

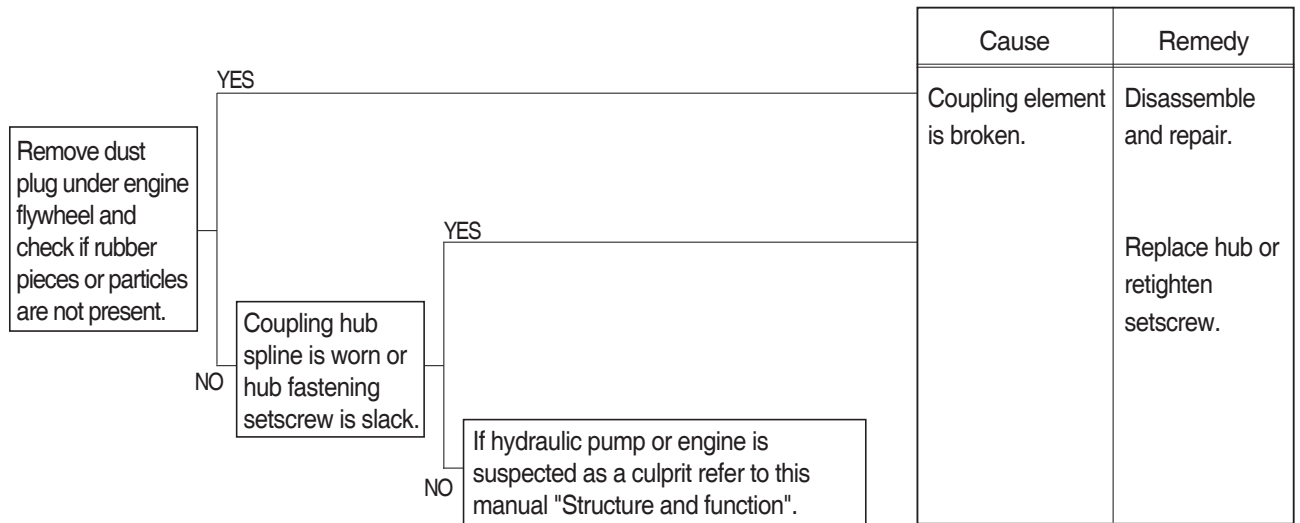

## 2) ENGINE STARTS BUT MACHINE DOES NOT OPERATE AT ALL

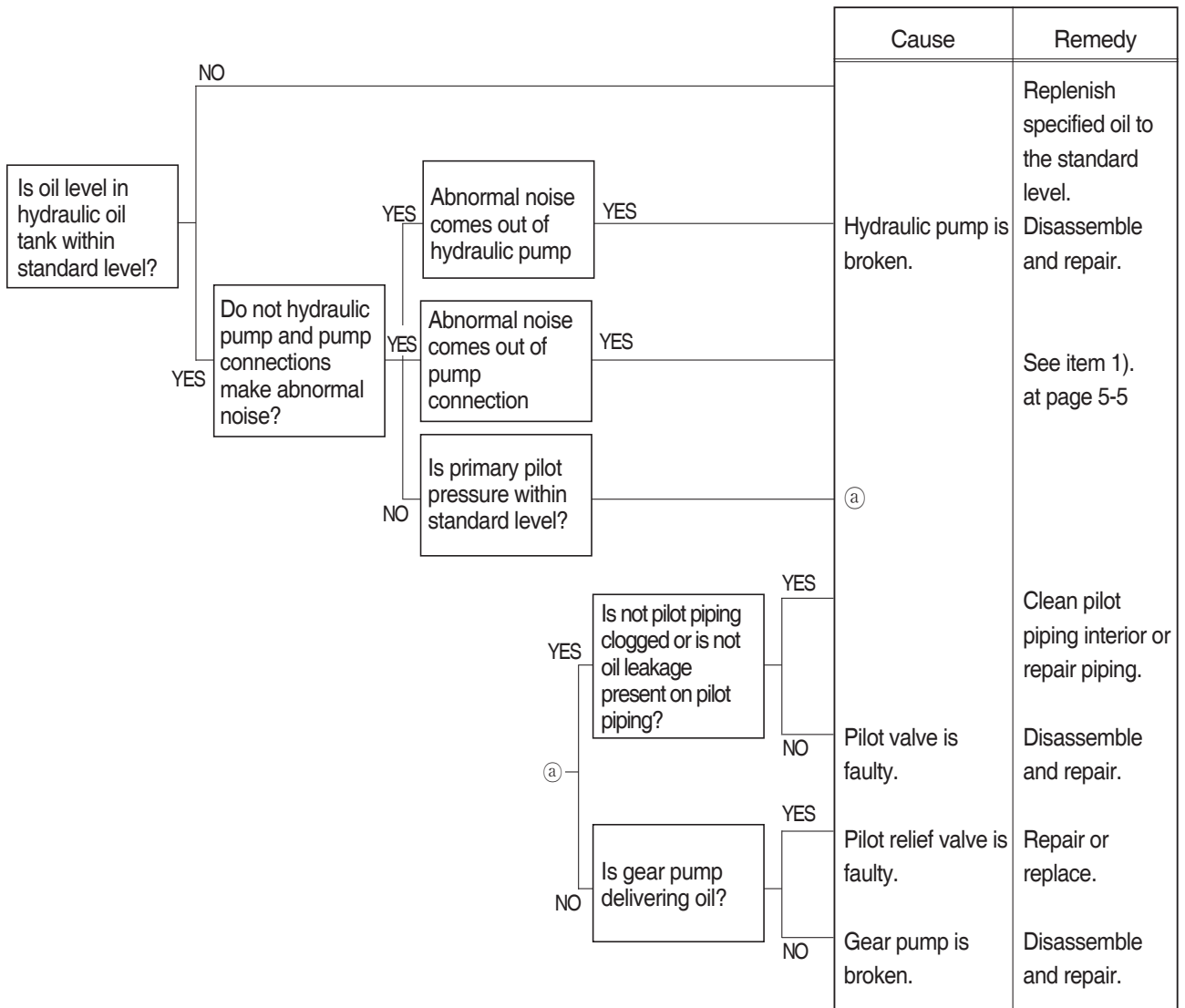

### 3. HYDRAULIC SYSTEM

#### 1) HYDRAULIC OIL IS CLOUDY

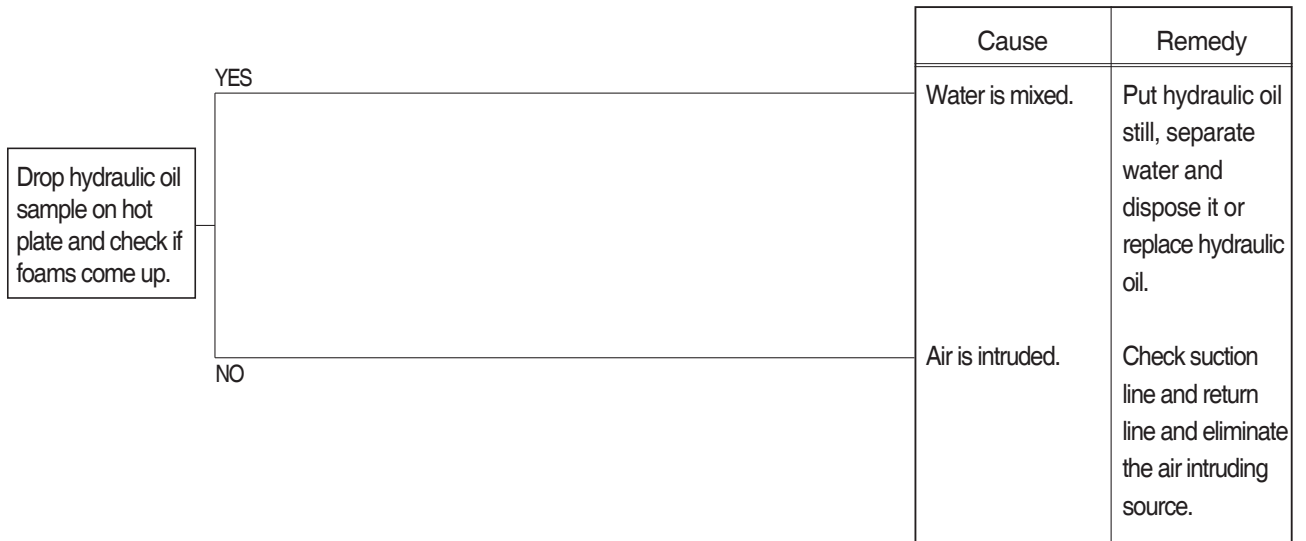

#### 2) HYDRAULIC OIL TEMPERATURE HAS RISEN ABNORMALLY

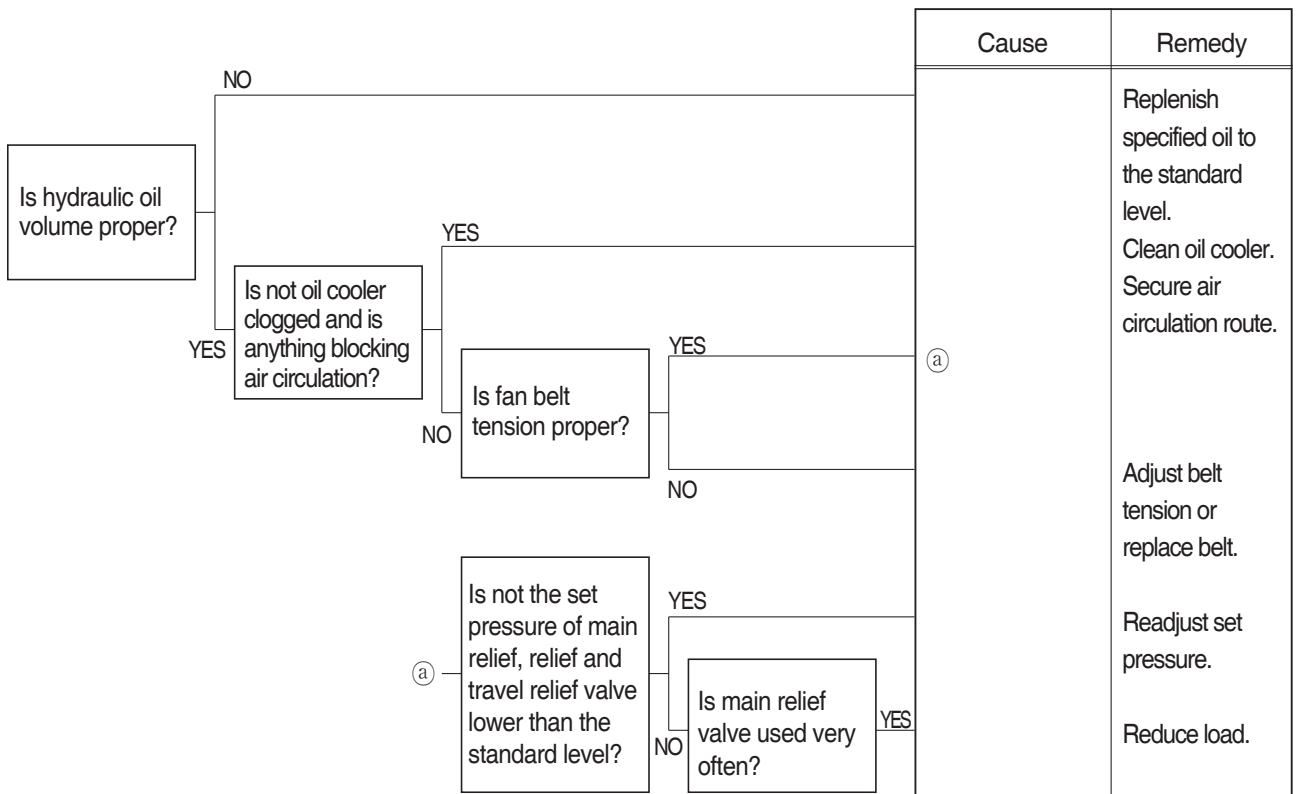



### 3) CAVITATION OCCURS WITH PUMP

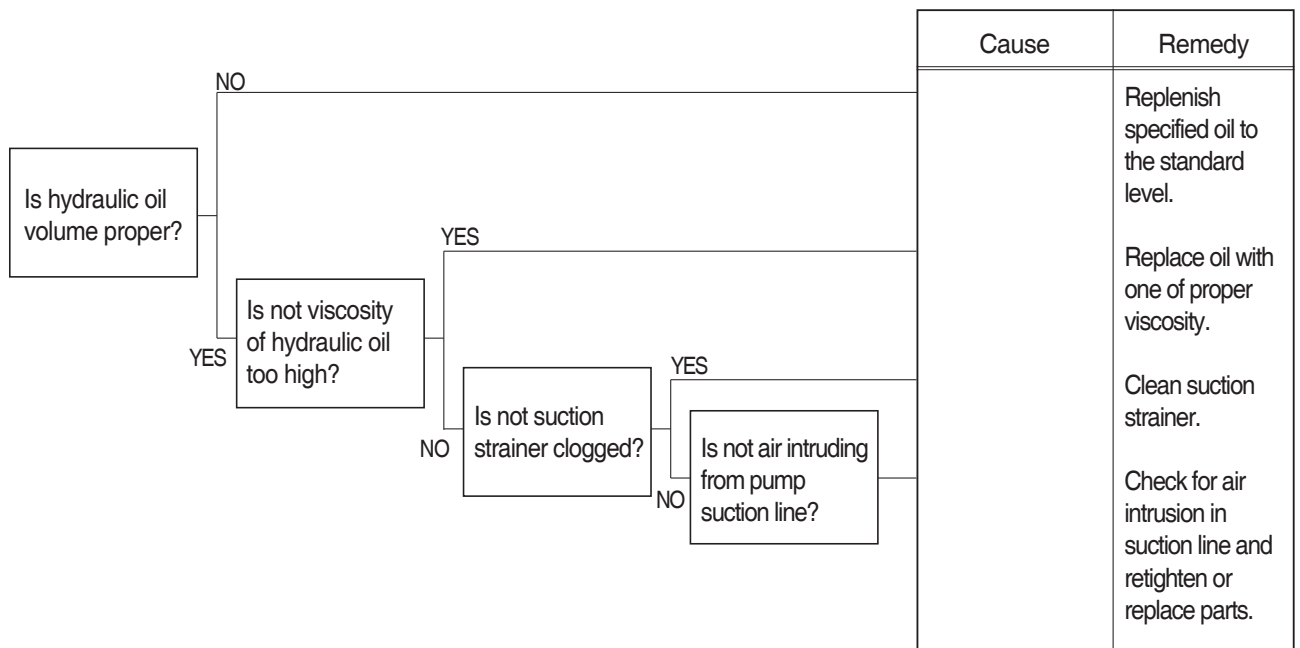

### 4) HYDRAULIC OIL IS CONTAMINATED

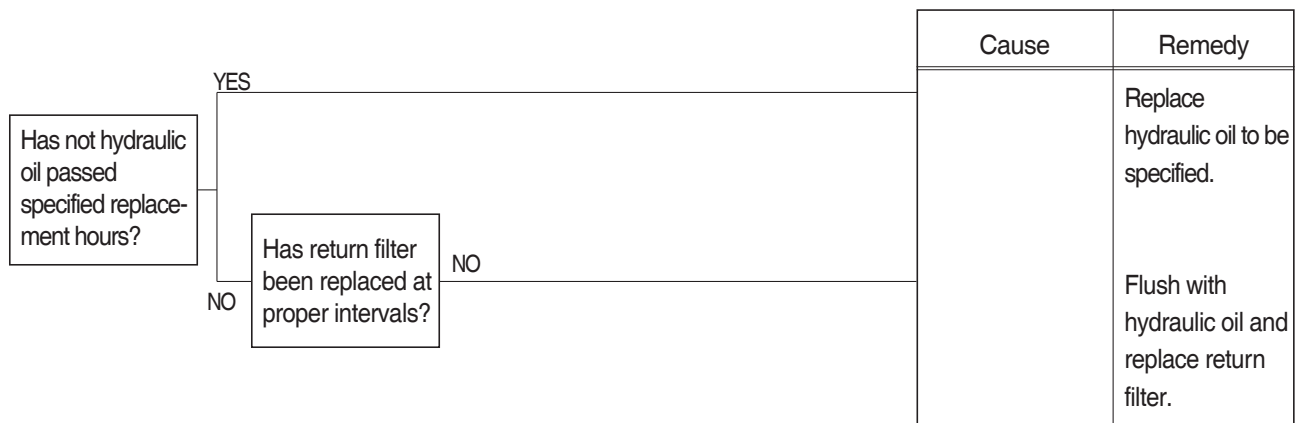

## 4. SWING SYSTEM

### 1) BOTH LH AND RH SWING ACTIONS ARE IMPOSSIBLE

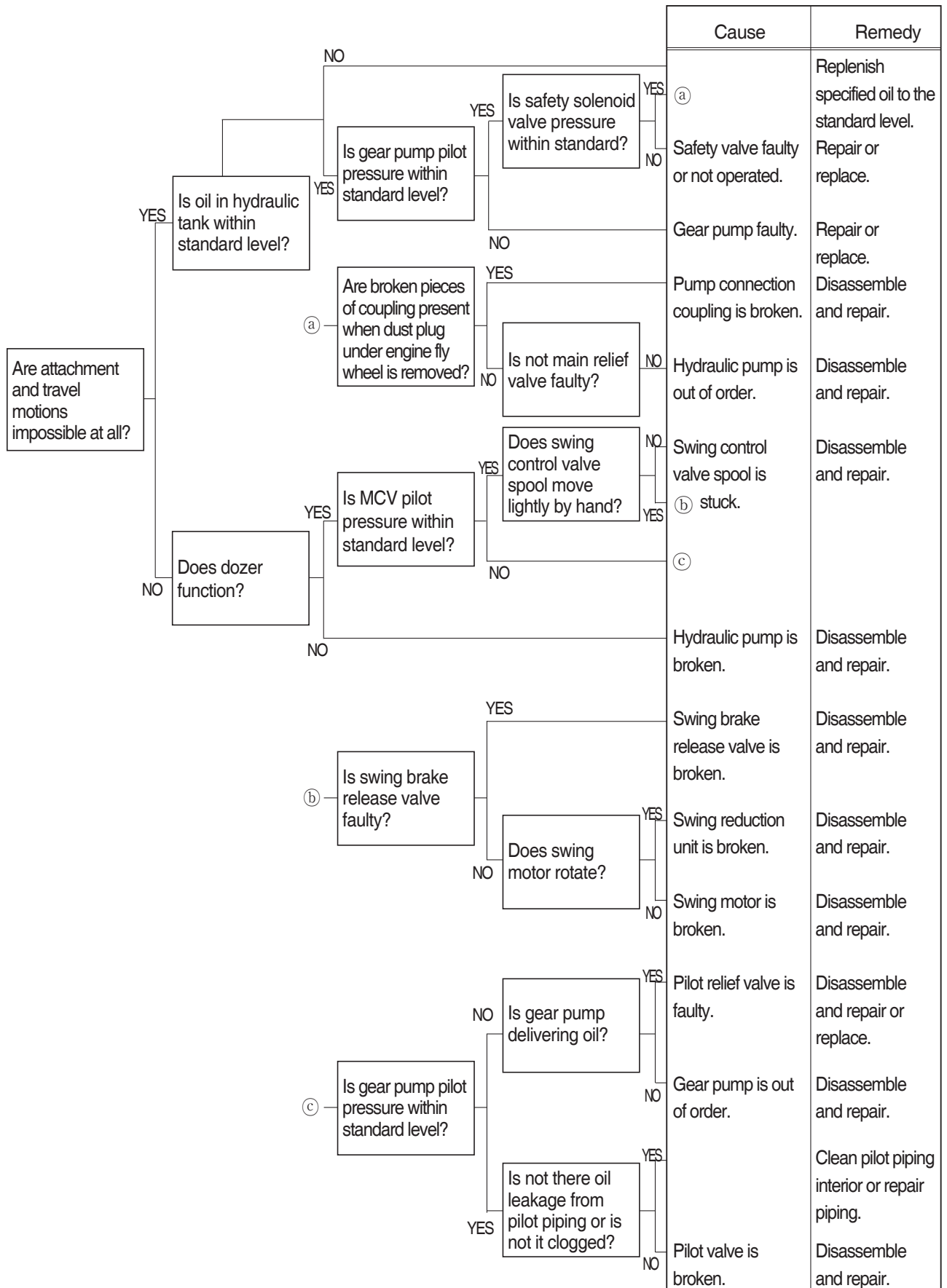

## 2) SWING SPEED IS LOW

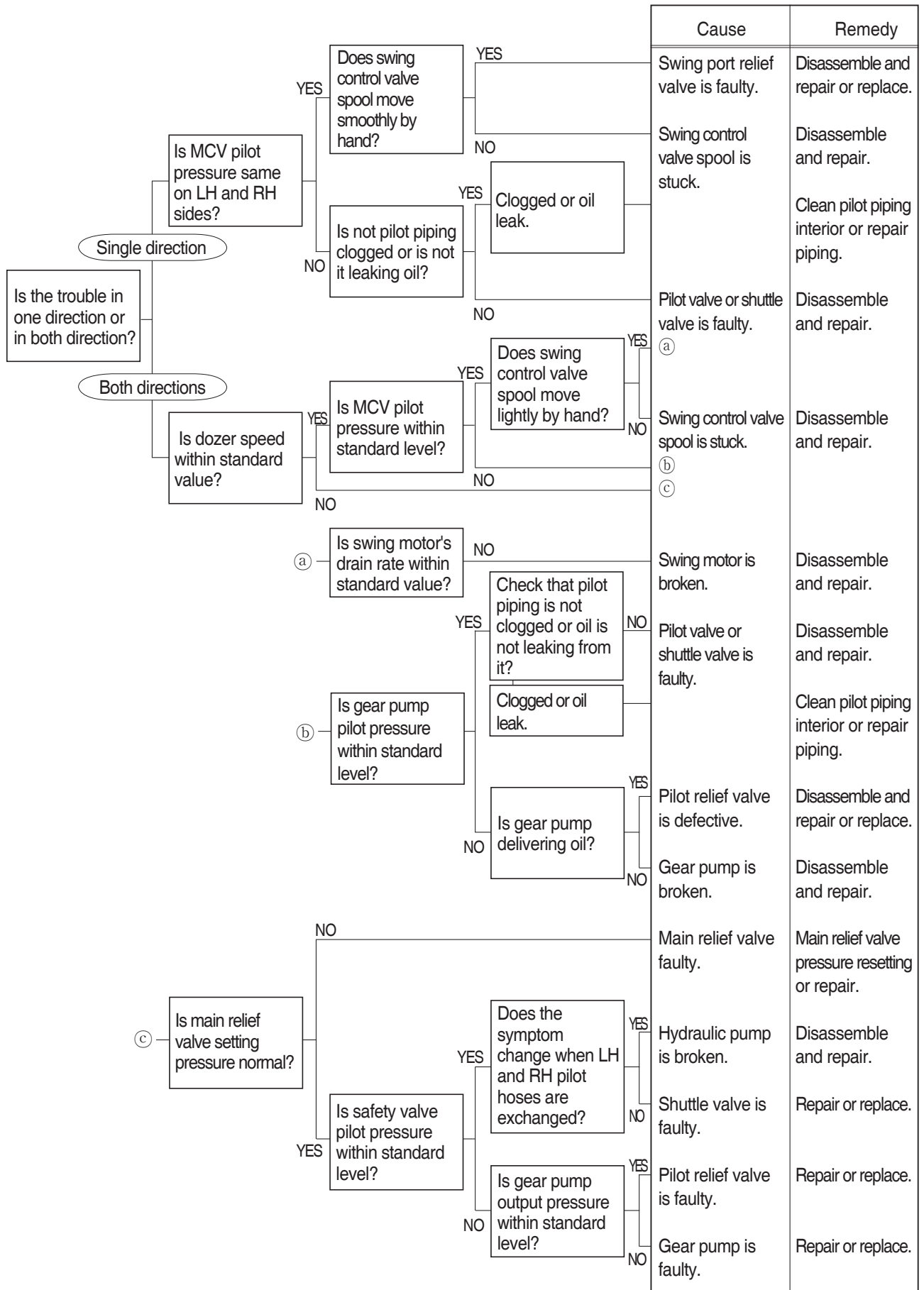

### 3) SWING MOTION IS IMPOSSIBLE IN ONE DIRECTION

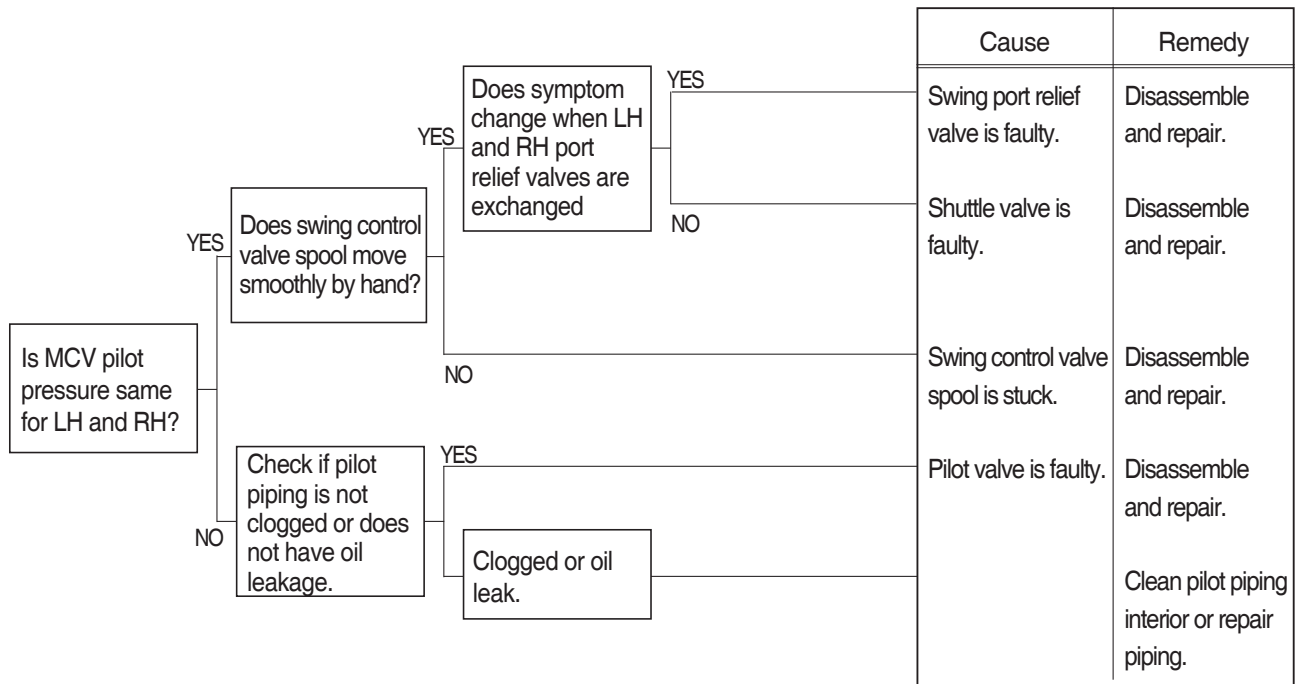

### 4) MACHINE SWINGS BUT DOES NOT STOP

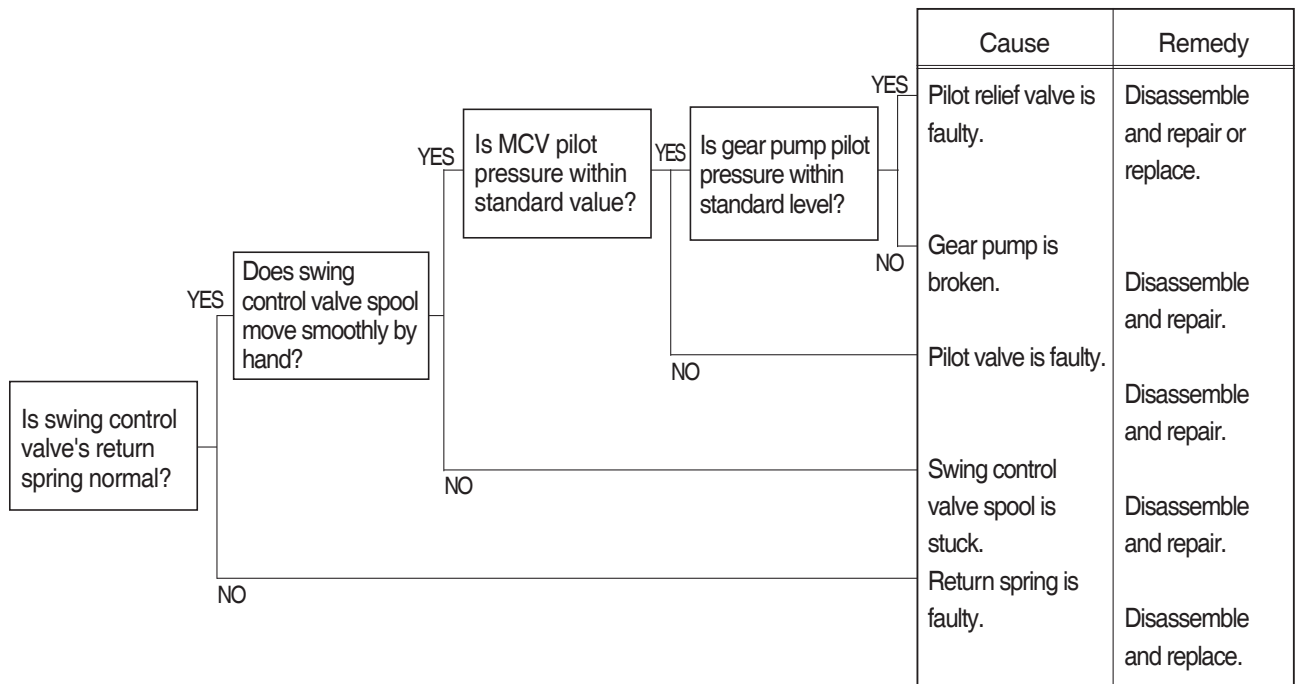

### 5) THE SWING UNIT DRIFTS WHEN THE MACHINE IS AT REST ON A SLOPE

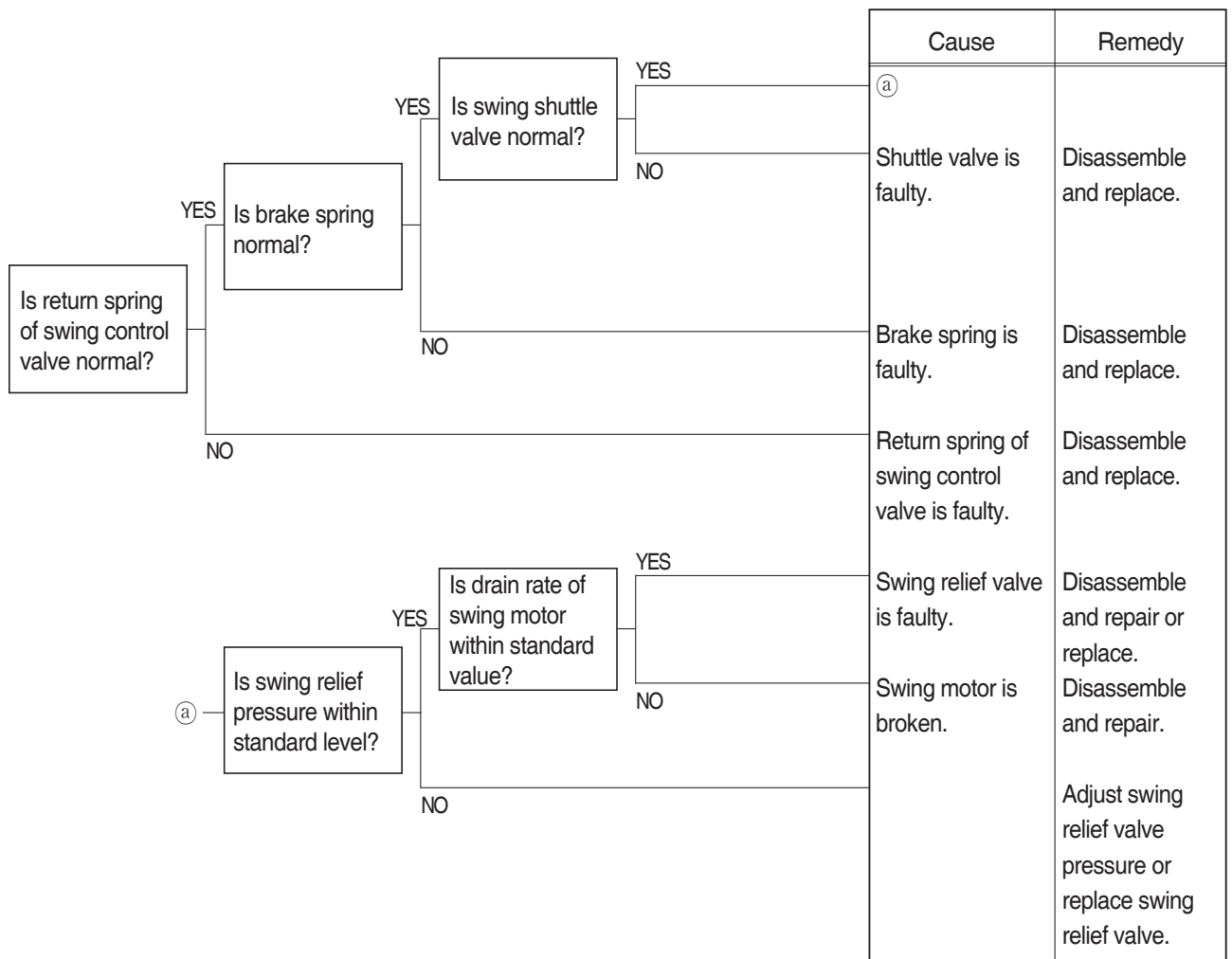

## 5. TRAVEL SYSTEM

### 1) TRAVEL DOES NOT FUNCTION AT ALL ON ONE SIDE

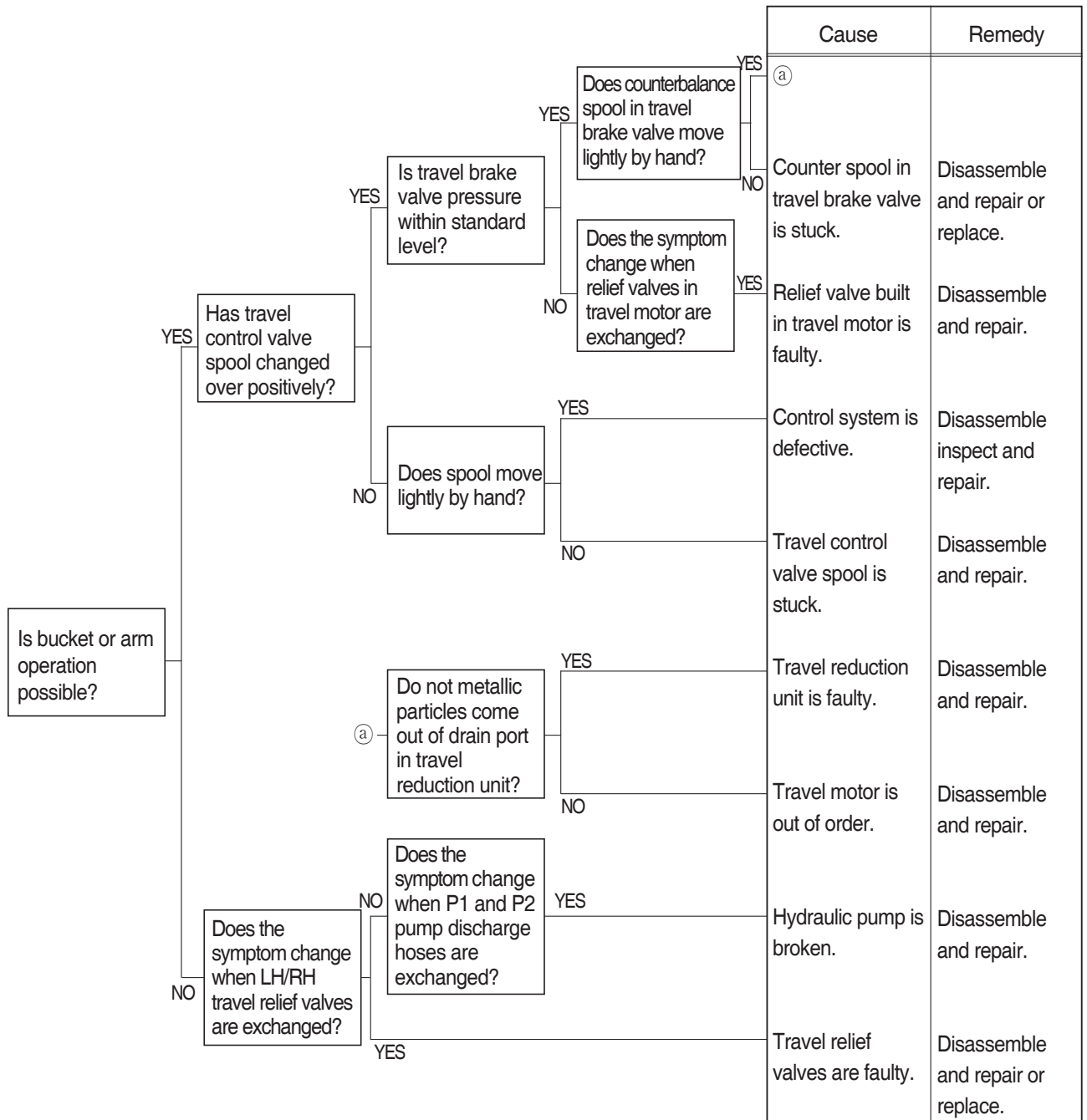

## 2) SPEED ON ONE SIDE FALLS AND THE MACHINE CURVES

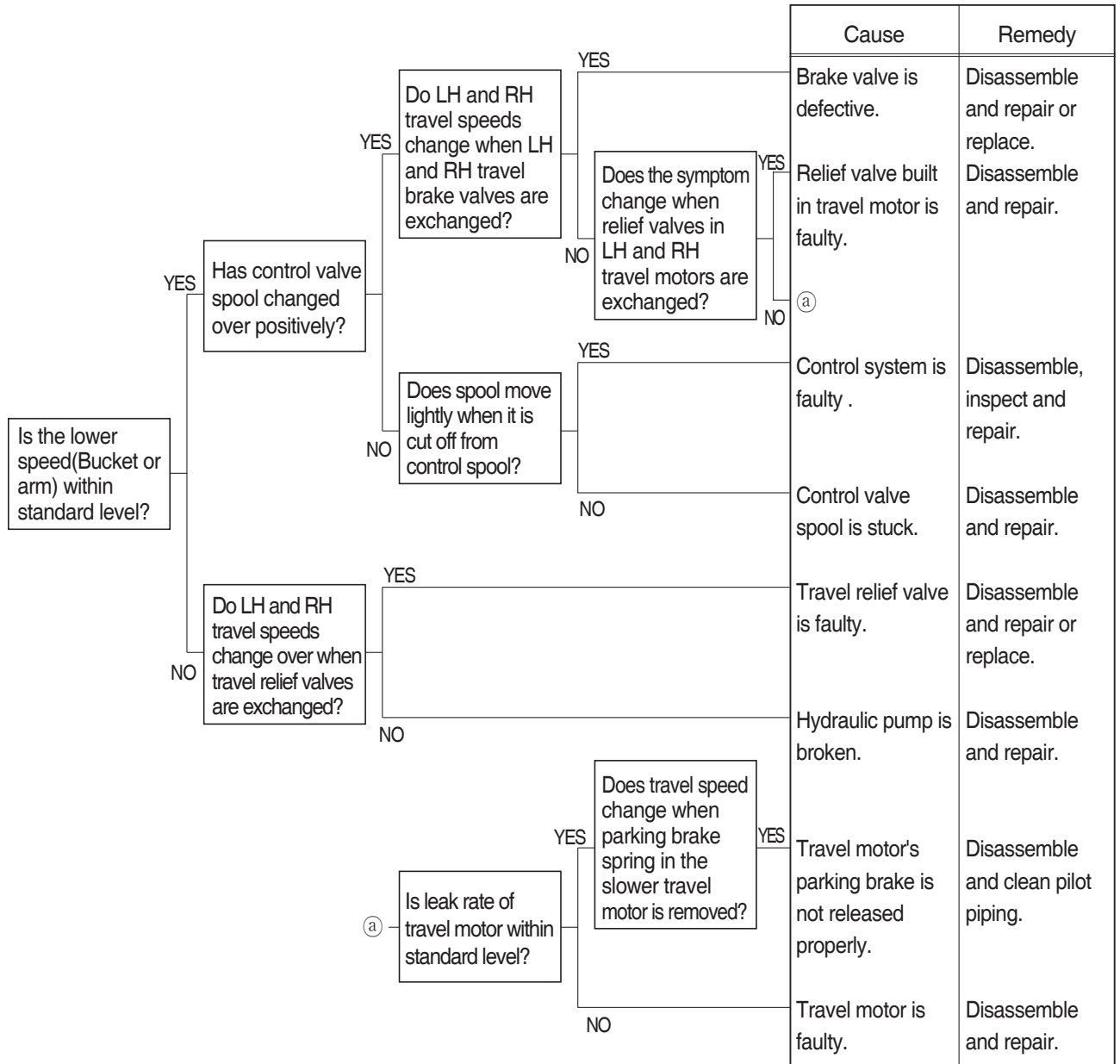

### 3) MACHINE DOES NOT STOP ON A SLOPE

Machine is pulled forward as sprocket rotates during digging operation.

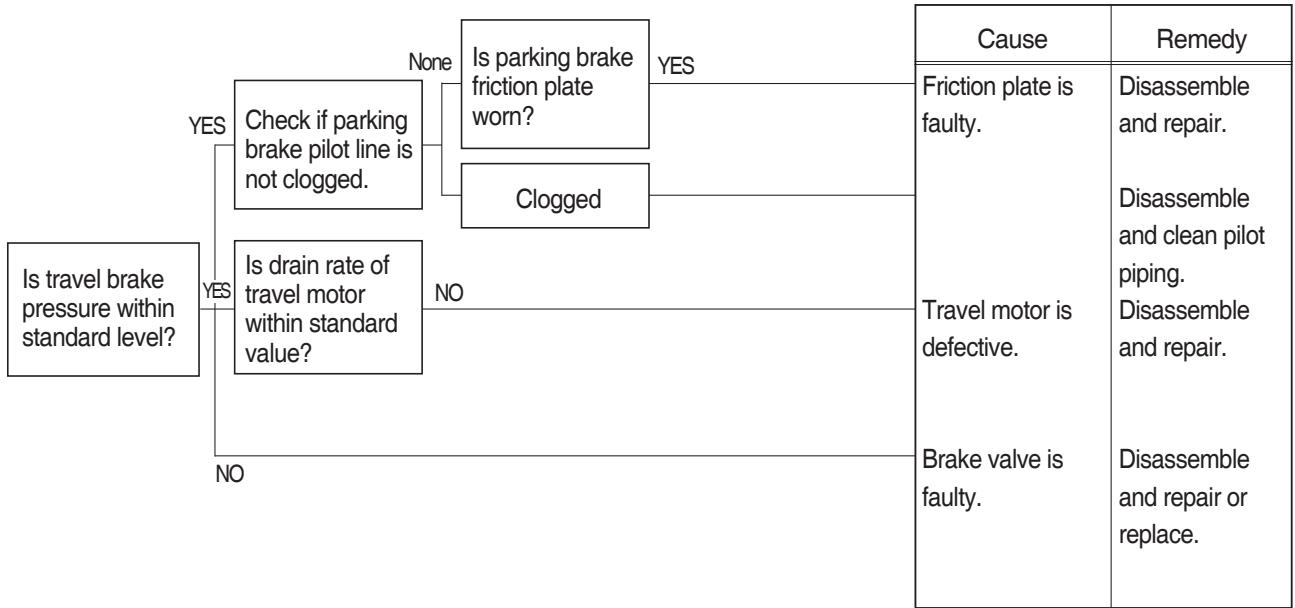

### 4) LH AND RH TRAVEL MOTIONS ARE IMPOSSIBLE

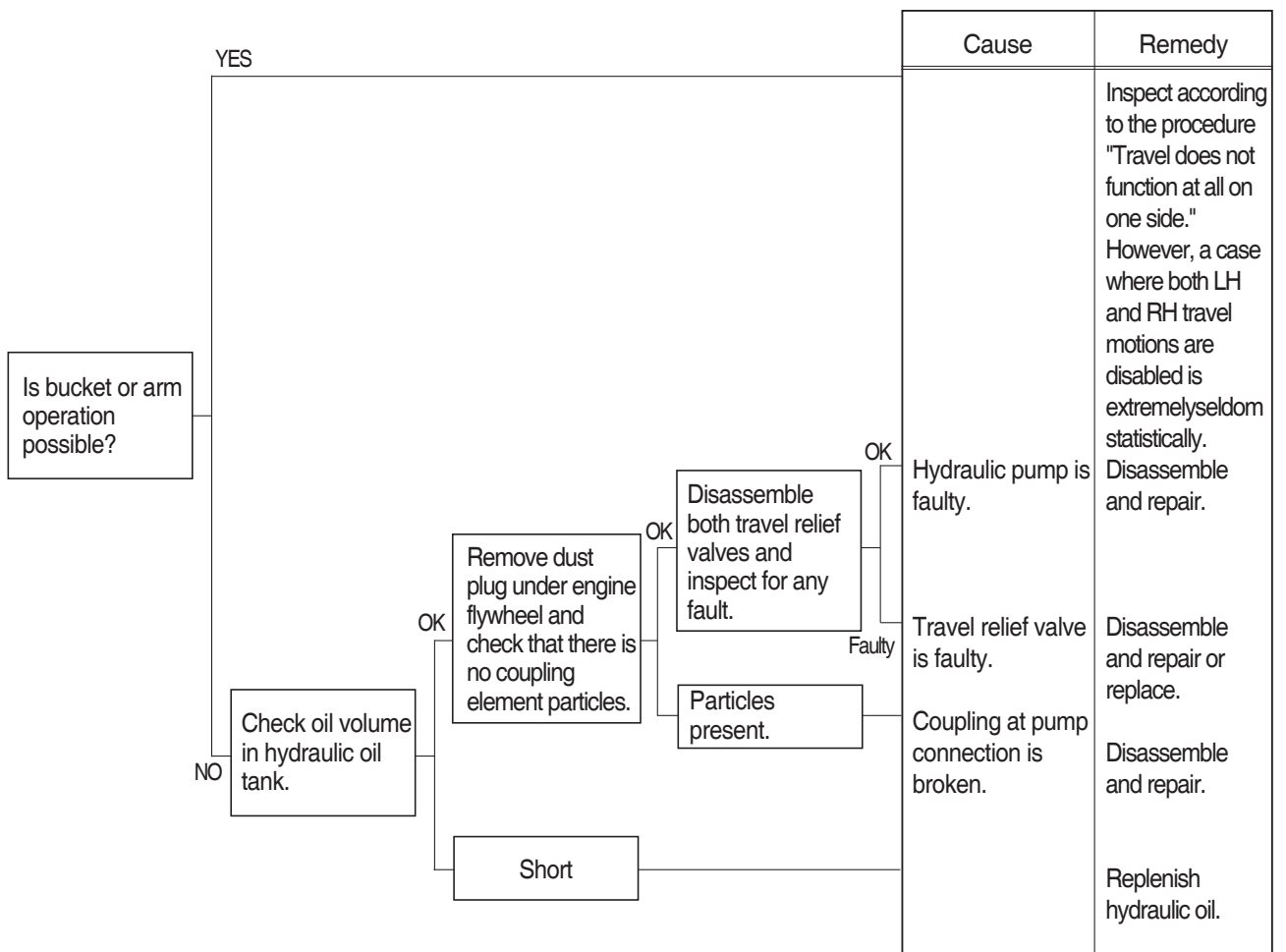



**5) TRAVEL ACTION IS POWERLESS (travel only)**

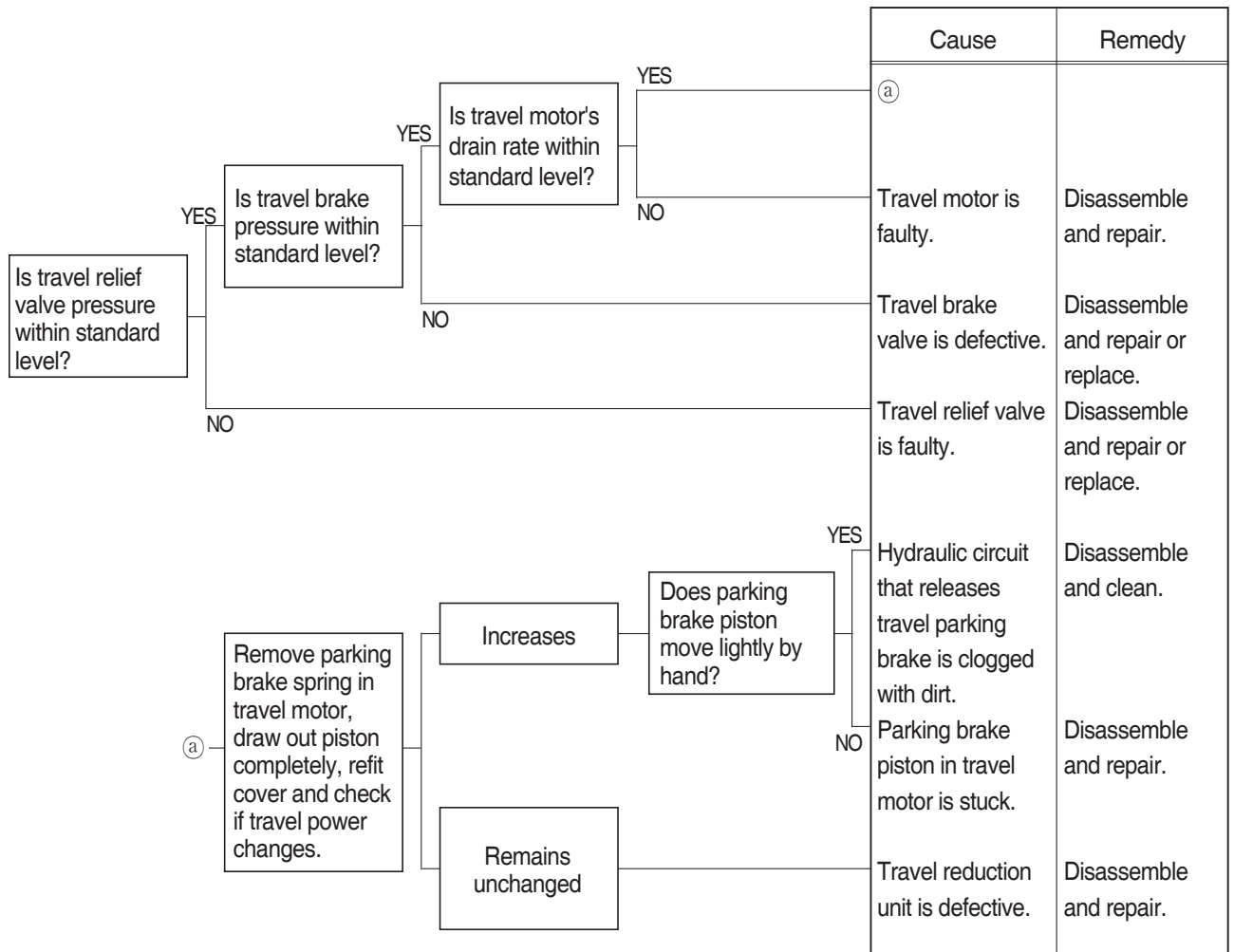

**6) MACHINE RUNS RECKLESSLY ON A SLOPE**



**7) MACHINE MAKES A CURVED TRAVEL OR DOES NOT TRAVEL AT ALL WHEN TRAVEL AND ATTACHMENT OPERATIONS ARE EXECUTED AT THE SAME TIME**

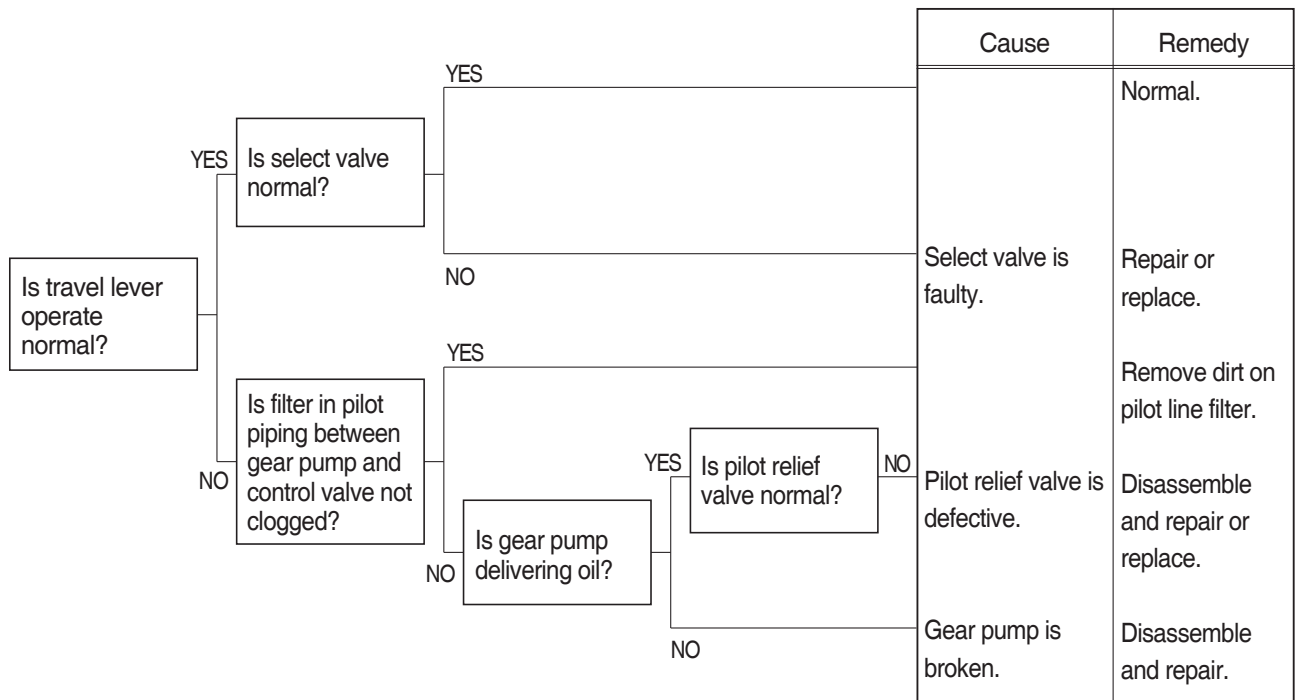

## 6. ATTACHMENT SYSTEM

### 1) BOOM OR ARM ACTION IS IMPOSSIBLE AT ALL

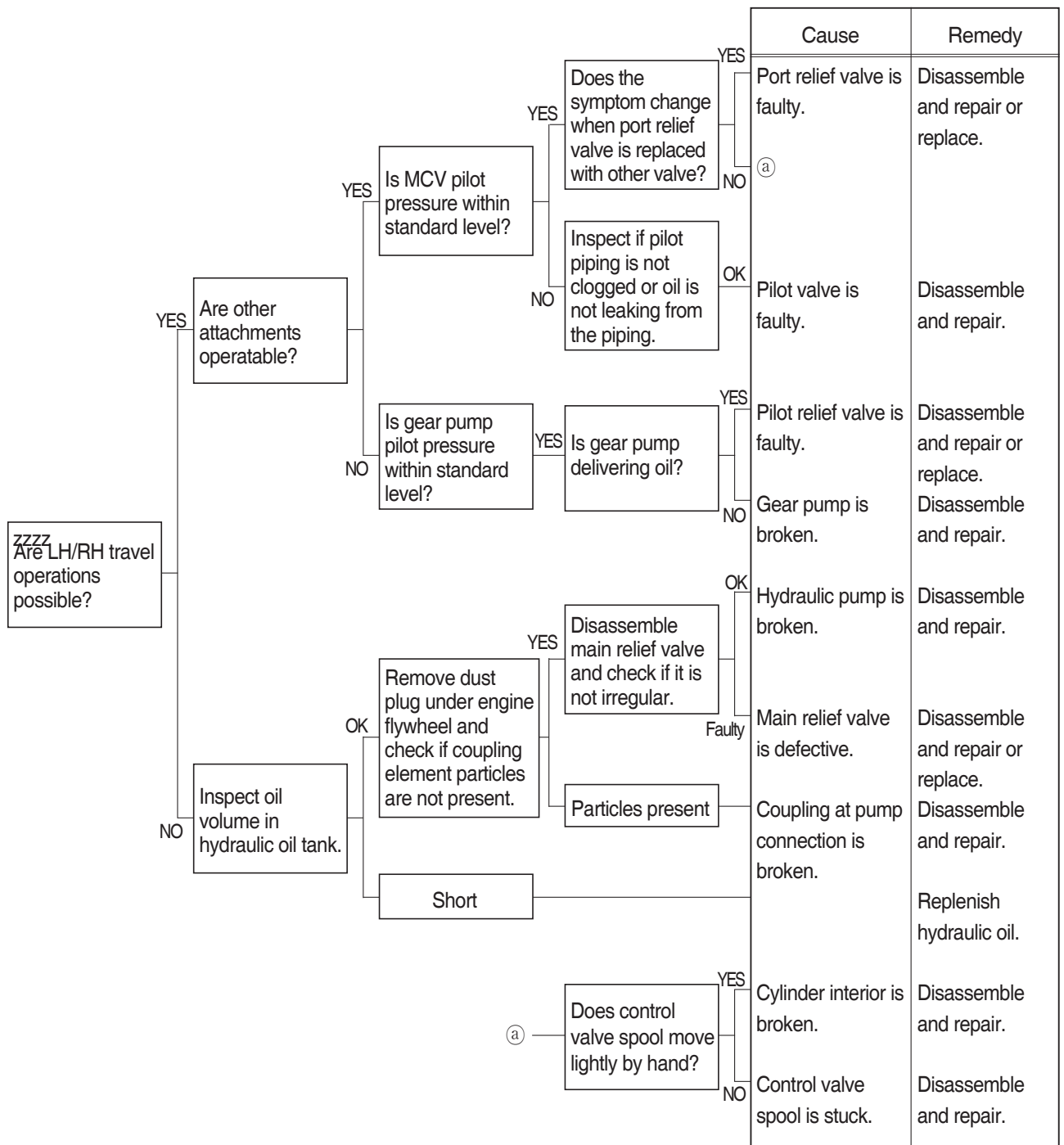

## 2) BOOM, ARM OR BUCKET SPEED IS LOW

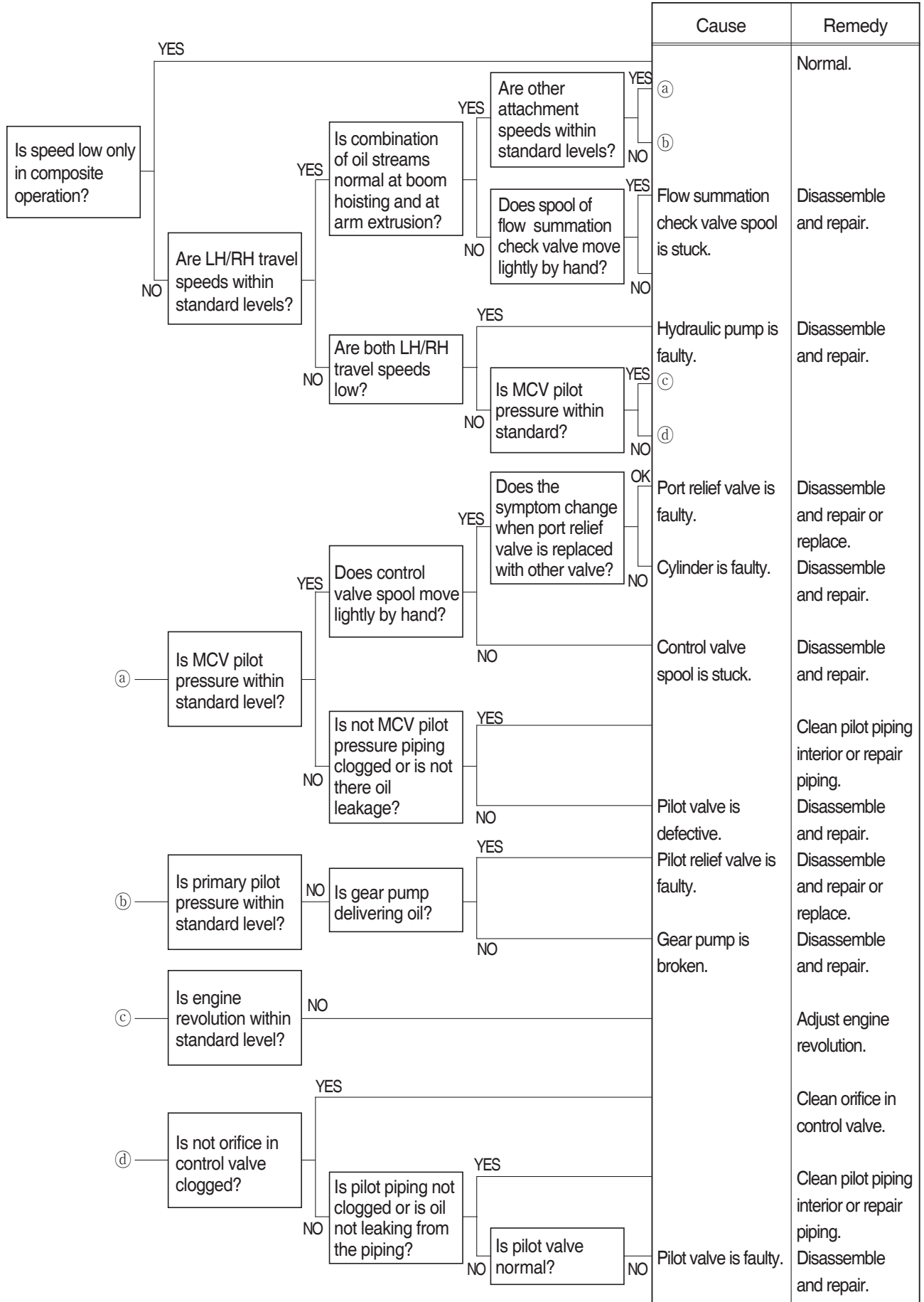

### 3) BOOM, ARM OR BUCKET CYLINDER EXTENDS OR CONTRACTS ITSELF AND ATTACHMENT FALLS

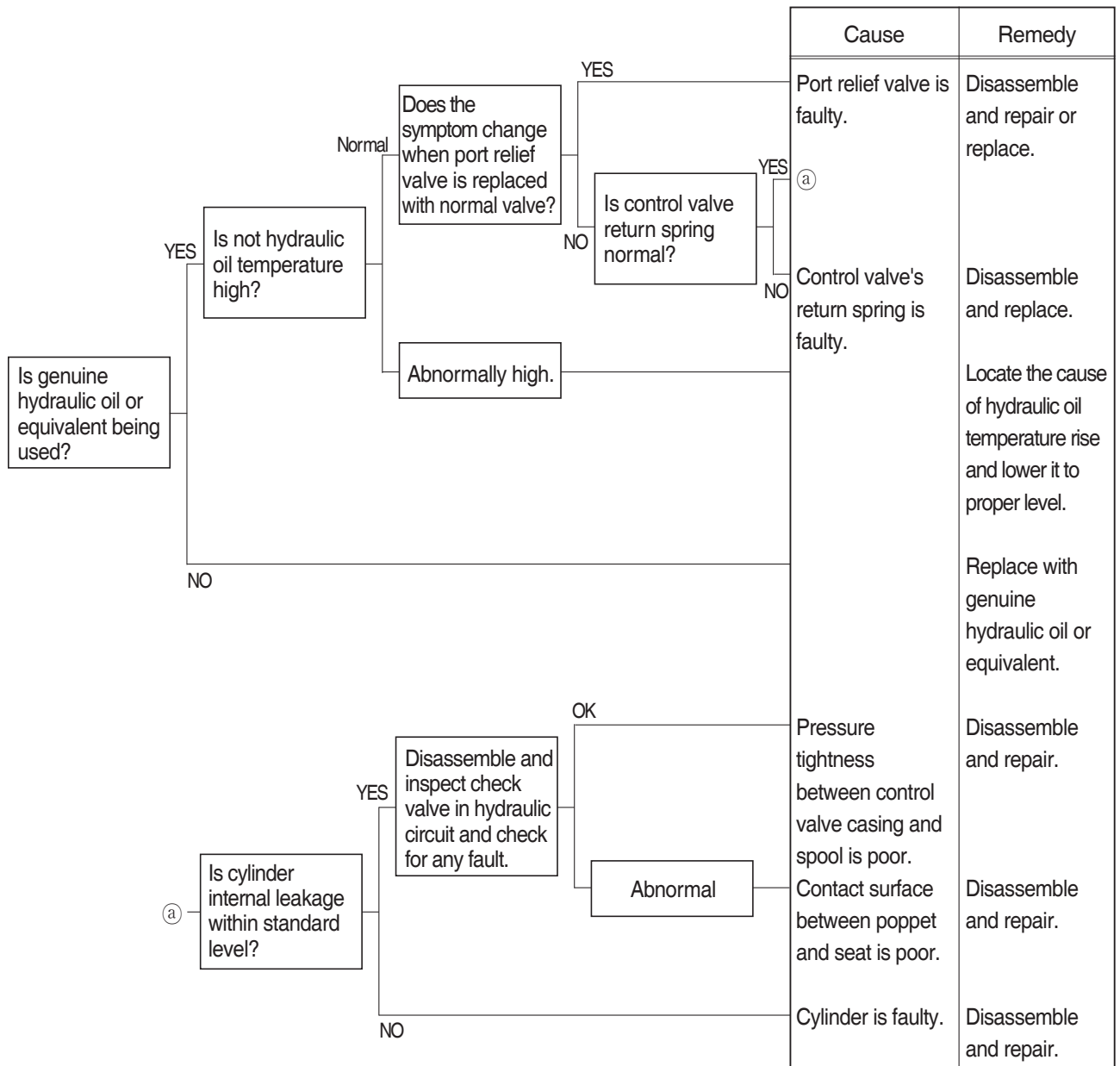

#### 4) BOOM, ARM OR BUCKET POWER IS WEAK

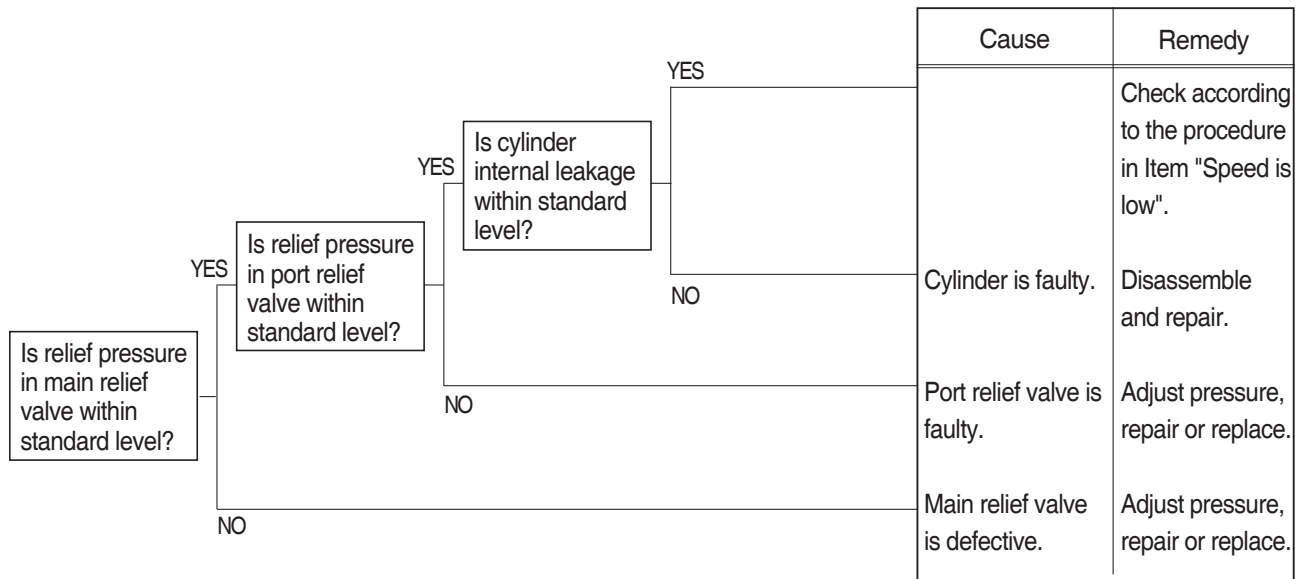

#### 5) ONLY BUCKET OPERATION IS TOTALLY IMPOSSIBLE

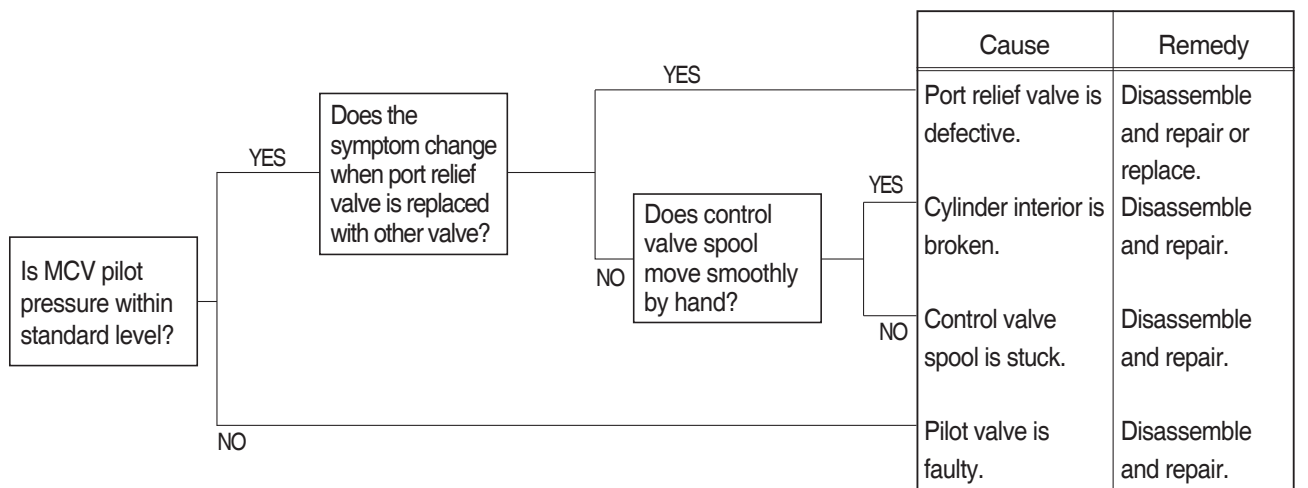

6) BOOM MAKES A SQUEAKING NOISE WHEN BOOM IS OPERATED

		Cause	Remedy
<p>Is boom foot pin greased sufficiently?</p>	<p>YES</p>		<p>Frictional noise occurs between the sliding faces of boom cylinder's oil seal and boom proper.</p> <p>※ Frictional noise will disappear if they are kept used.</p>
	<p>NO</p>	<p>Boom foot pin has run out of grease.</p>	<p>Supply grease to it.</p> <p>※ If seizure is in an initial stage, supply sufficient grease. If seizure is in a grown state, correct it by paper lapping or with an oil stone.</p>

## ※ HOW TO CHECK INTERNAL BOOM CYLINDER LEAKAGE

1. Lower the bucket teeth to the ground with bucket cylinder fully retracted and arm cylinder rod retracted almost in full.

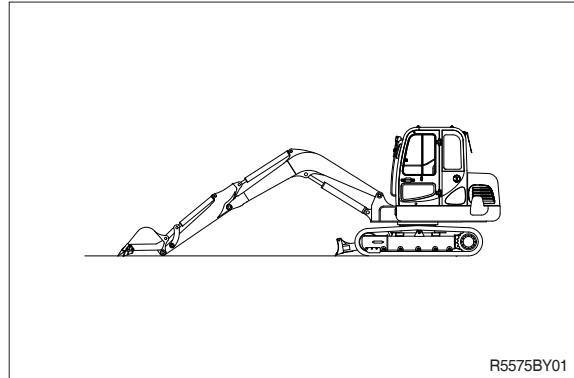

2. Disconnect hose(A) from rod side of boom cylinder and drain oil from cylinders and hose.(Put cups on piping and hose ends)

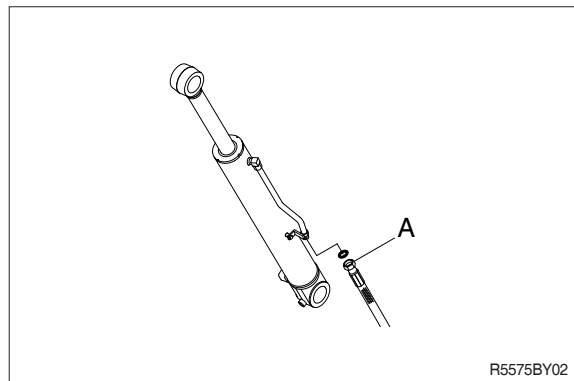

3. Raise bucket OFF the ground by retracting the arm cylinder rod.

If oil leaks from piping side and boom cylinder rod is retracted there is an internal leak in the cylinder.

If no oil leaks from piping side and boom cylinder rod is retracted, there is an internal leak in the control valve.

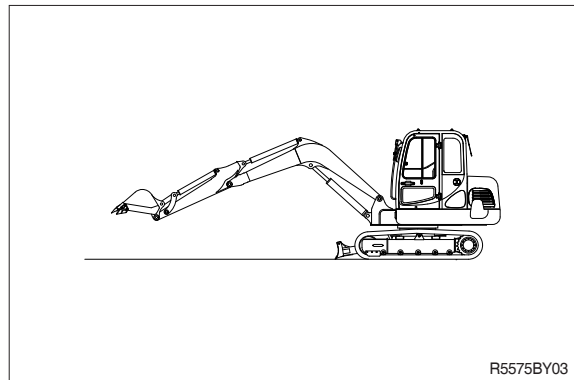



## GROUP 3 ELECTRICAL SYSTEM

### 1. WHEN STARTING SWITCH IS TURNED ON, MONITOR PANEL DISPLAY DOES NOT APPEAR

- Before disconnecting the connector, always turn the starting switch OFF.
- Before carrying out below procedure, check all the related connectors are properly inserted and short of fuse No.3 and No.8.
- After checking, insert the disconnected connectors again immediately unless otherwise specified.

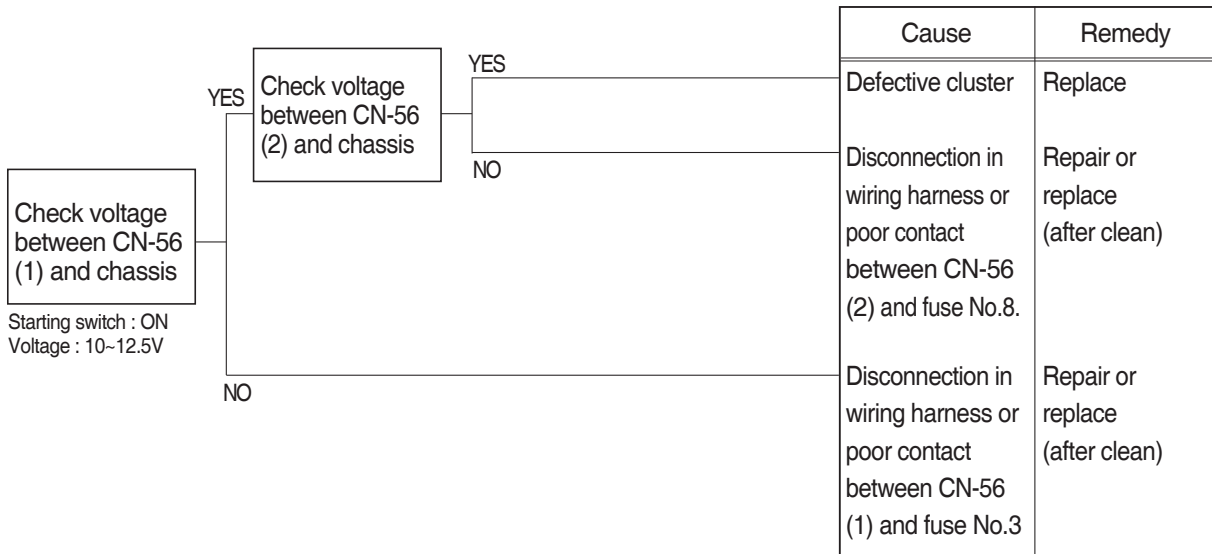

Check voltage

YES	10 ~ 12.5V
NO	0V

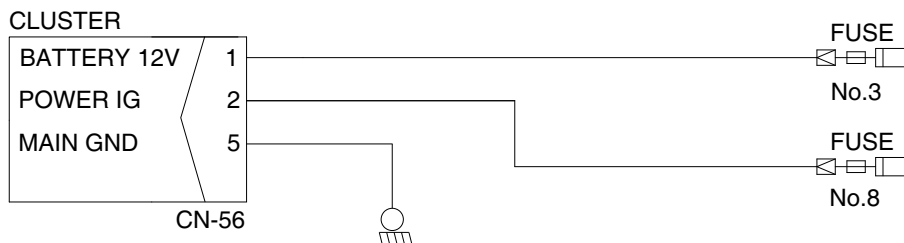

65A5TS10

## 2. BATTERY CHARGING WARNING LAMP LIGHTS UP (starting switch : ON)

- Before disconnecting the connector, always turn the starting switch OFF.
- Before carrying out below procedure, check all the related connectors are properly inserted.
- After checking, insert the disconnected connectors again immediately unless otherwise specified.

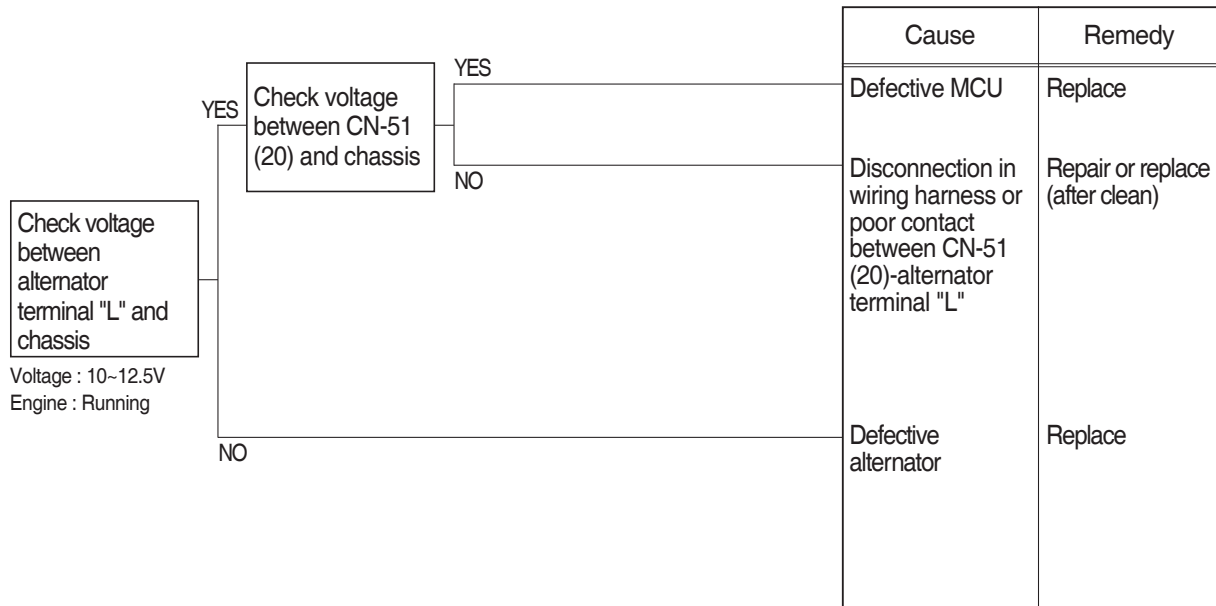

Check voltage

YES	10~12.5V
NO	0V

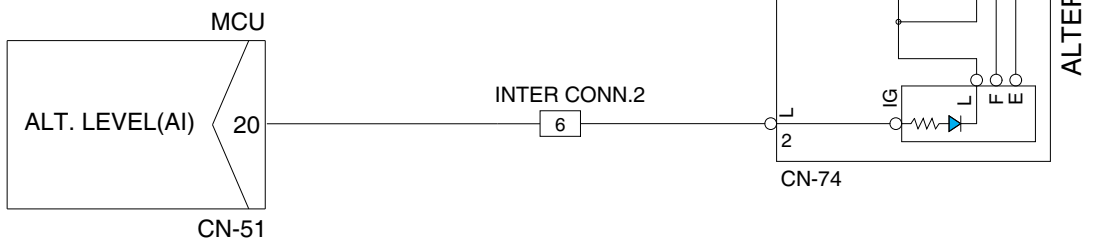

65A5TS11

### 3. WHEN COOLANT OVERHEAT WARNING LAMP LIGHTS UP (engine is started)

- Before disconnecting the connector, always turn the starting switch OFF.
- Before carrying out below procedure, check all the related connectors are properly inserted.
- After checking, insert the disconnected connectors again immediately unless otherwise specified.

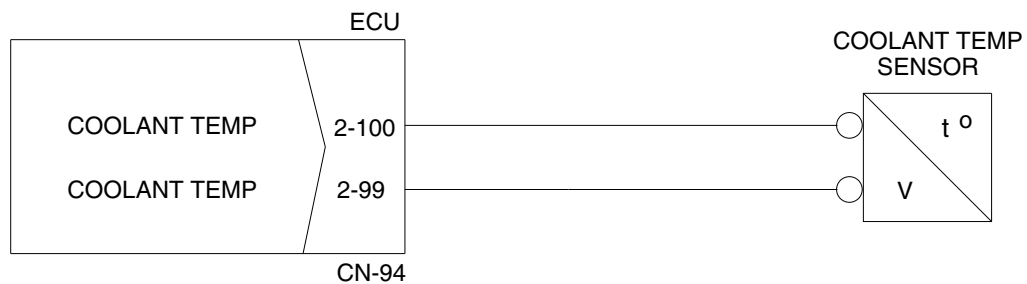
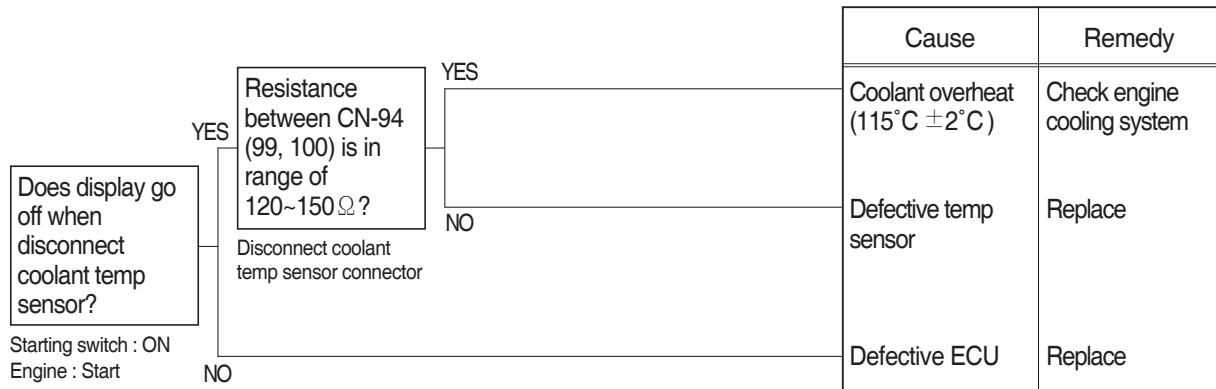

65A5TS12

#### 4. WHEN AIR CLEANER WARNING LAMP LIGHTS UP (engine is started)

- Before disconnecting the connector, always turn the starting switch OFF.
- Before carrying out below procedure, check all the related connectors are properly inserted.
- After checking, insert the disconnected connectors again immediately unless otherwise specified.

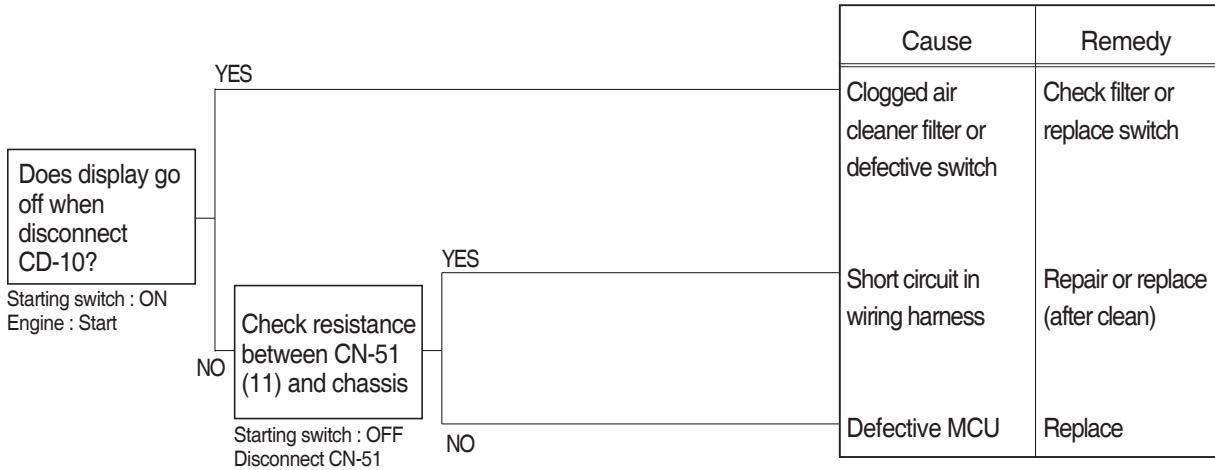

#### Check resistance

YES	MAX 1Ω
NO	MIN 1MΩ

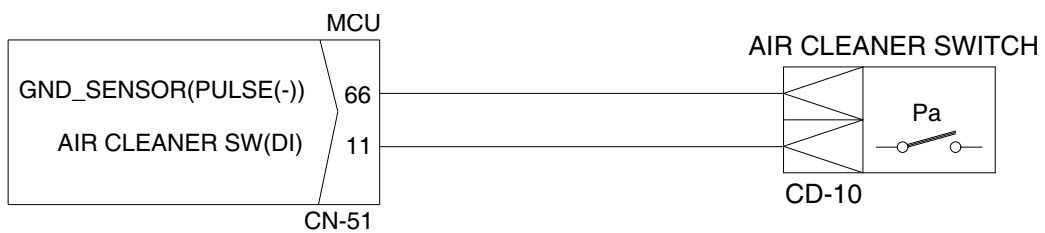

65A5TS13

## 5. WHEN ENGINE OIL PRESSURE WARNING LAMP LIGHTS UP (engine is started)

- Before disconnecting the connector, always turn the starting switch OFF.
- Before carrying out below procedure, check all the related connectors are properly inserted.
- After checking, insert the disconnected connectors again immediately unless otherwise specified.

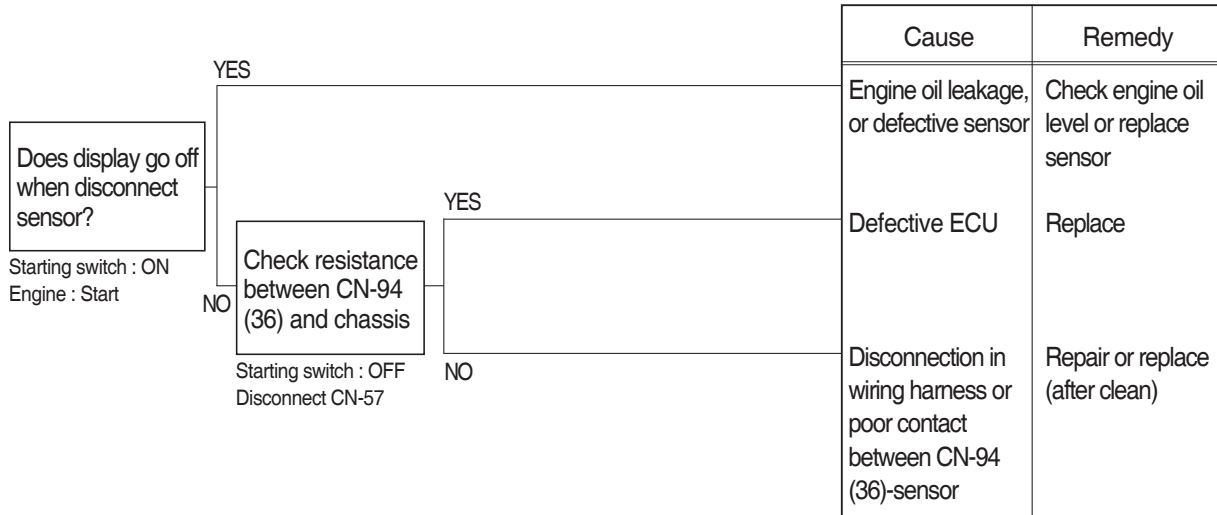

### Check resistance

YES	MAX 1Ω
NO	MIN 1MΩ

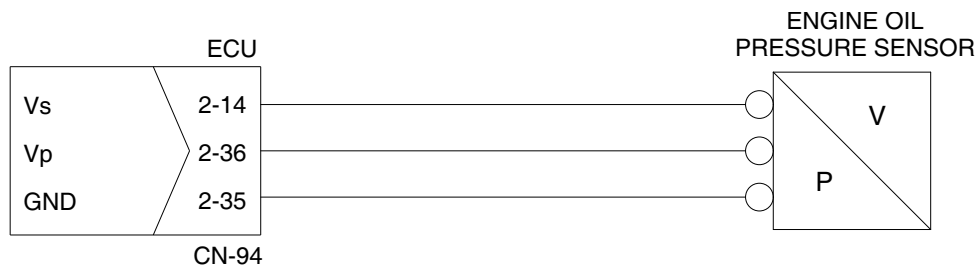

## 6. WHEN HYDRAULIC OIL TEMPERATURE WARNING LAMP LIGHTS UP (engine is started)

- Before disconnecting the connector, always turn the starting switch OFF.
- Before carrying out below procedure, check all the related connectors are properly inserted.
- After checking, insert the disconnected connectors again immediately unless otherwise specified.

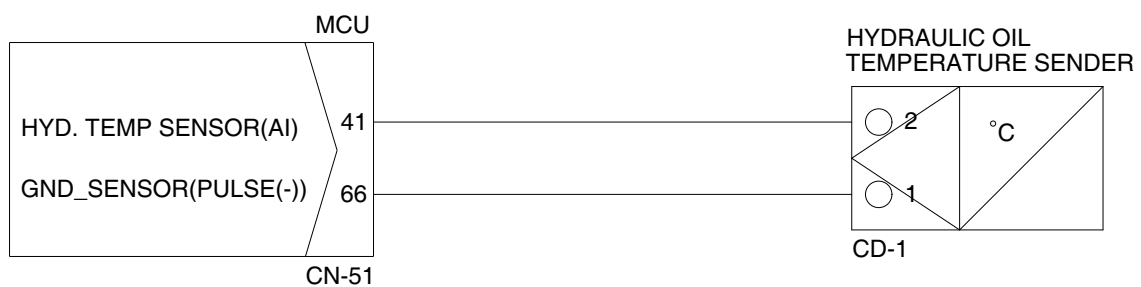
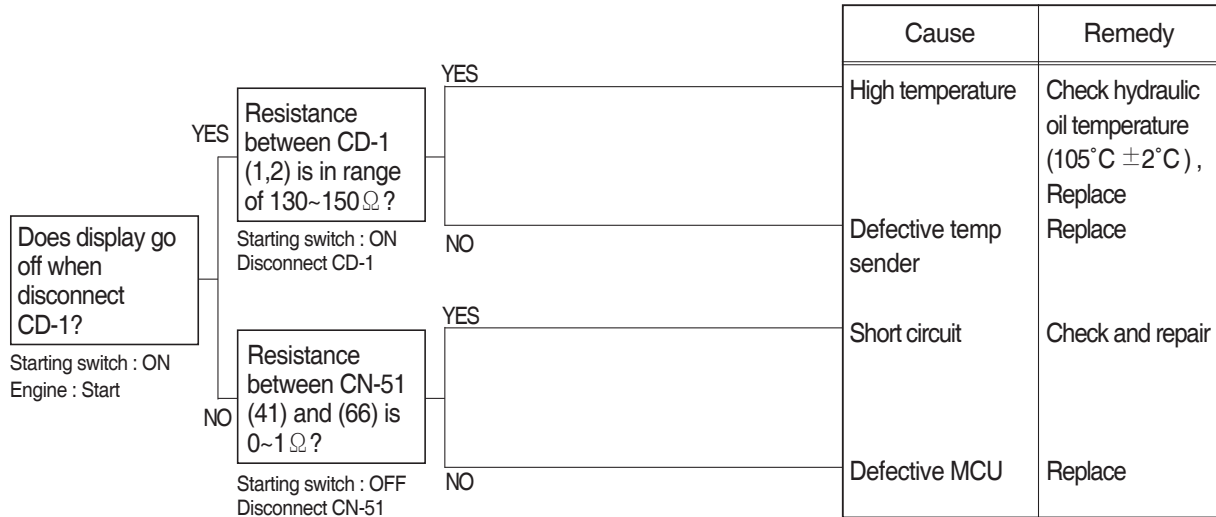

65A5TS15

## 7. WHEN COOLANT TEMPERATURE GAUGE DOES NOT OPERATE

- Before disconnecting the connector, always turn the starting switch OFF.
- Before carrying out below procedure, check all the related connectors are properly inserted.
- After checking, insert the disconnected connectors again immediately unless otherwise specified.

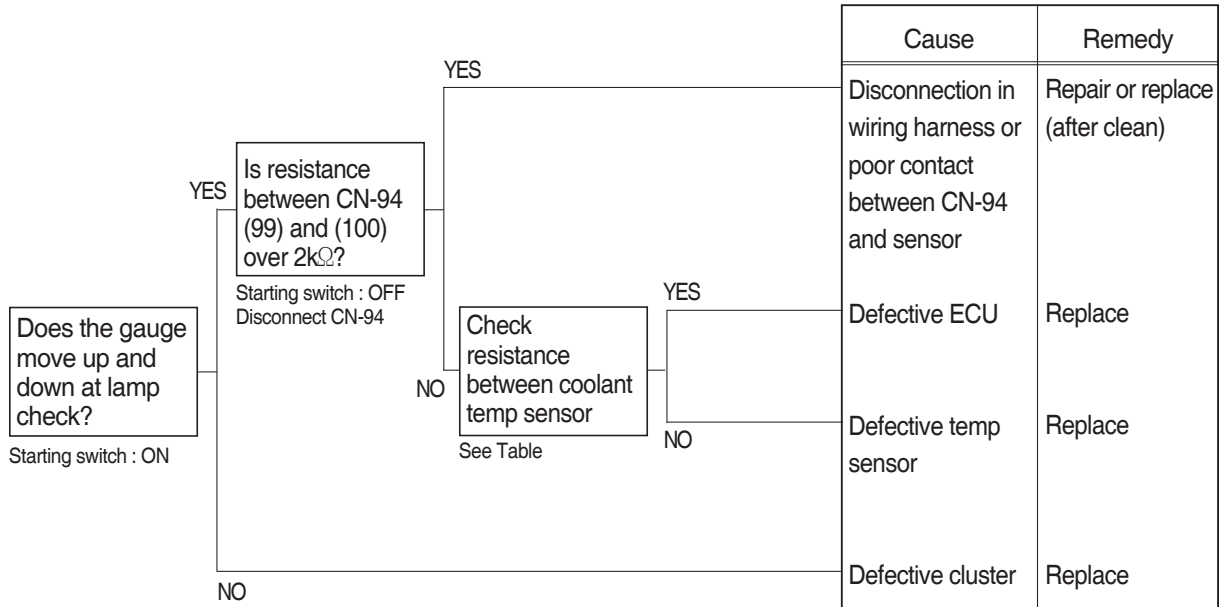

Check Table

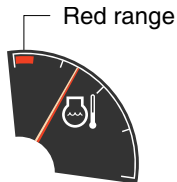

Temperature \ Item	40°C	85~110°C	115°C (red range)
Unit Resistance( $\Omega$ )	1170~	270~130	~124
Tolerance(%)	$\pm 5$	-8~0	$\pm 5$

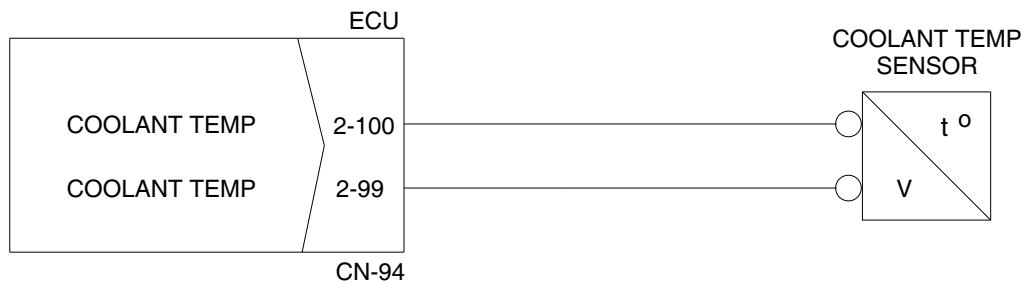

## 8. WHEN FUEL GAUGE DOES NOT OPERATE (check warning lamp ON/OFF)

- Before disconnecting the connector, always turn the starting switch OFF.
- Before carrying out below procedure, check all the related connectors are properly inserted.
- After checking, insert the disconnected connectors again immediately unless otherwise specified.

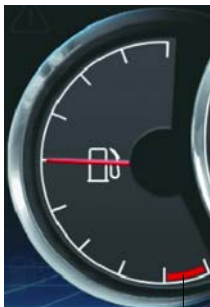
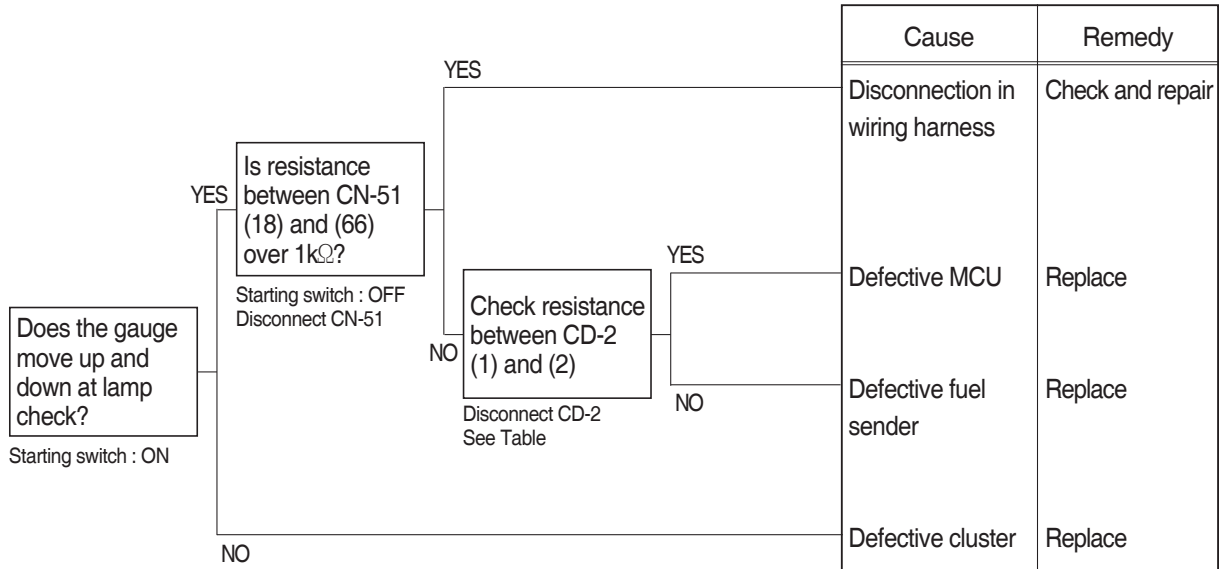

Empty

Check Table

Item \ Level	Empty	1/2	Full
Unit Resistance ( $\Omega$ )	700	300	~100
Tolerance (%)	$\pm 5$	$\pm 8$	$\pm 5$

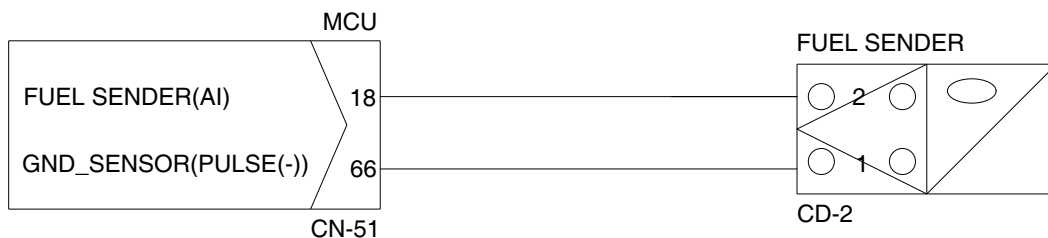

65A5TS17



## 9. WHEN SAFETY SOLENOID DOES NOT OPERATE

- Before disconnecting the connector, always turn the starting switch OFF.
- Before carrying out below procedure, check all the related connectors are properly inserted and short of fuse No.20.
- After checking, insert the disconnected connectors again immediately unless otherwise specified.

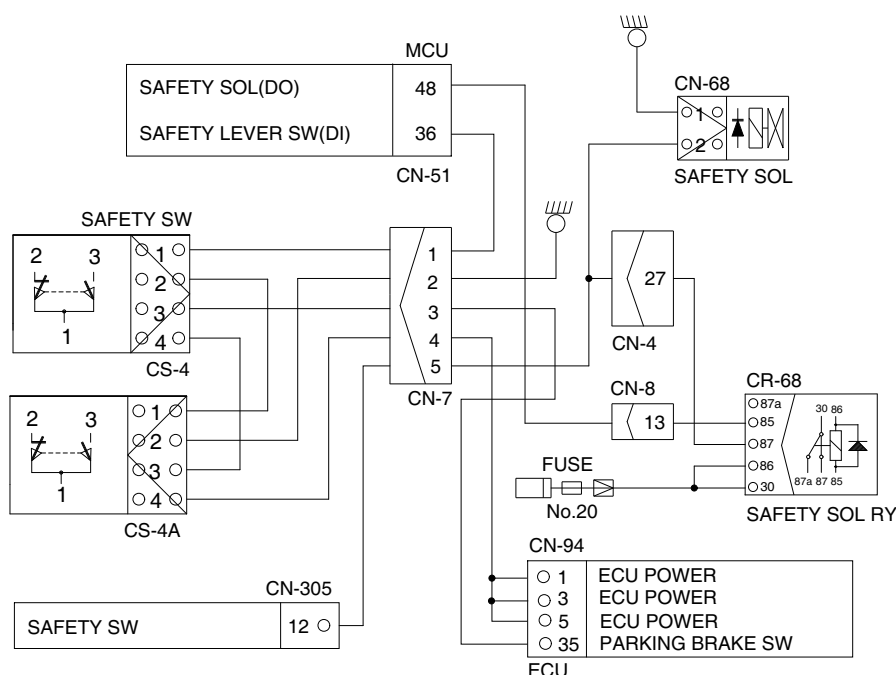
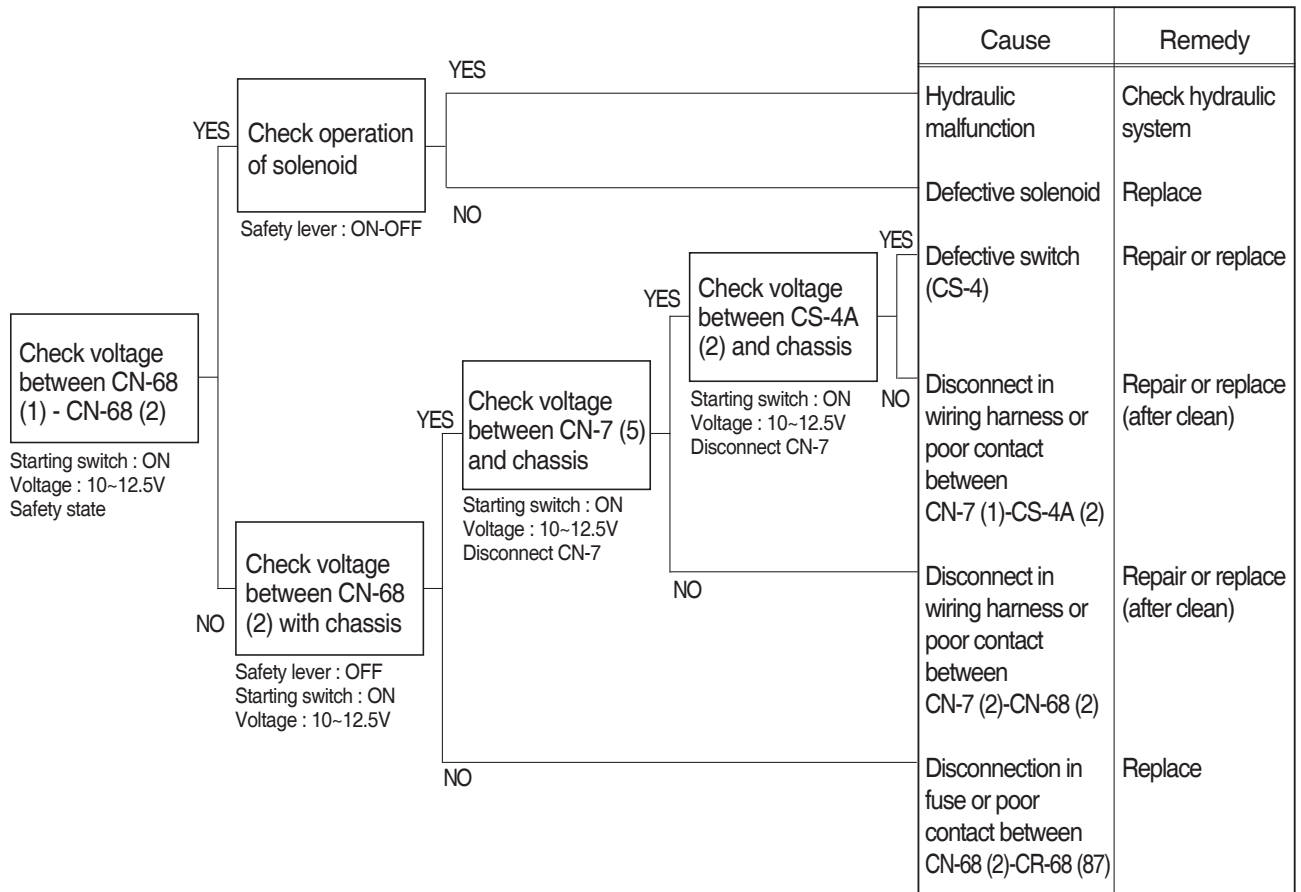

65A5TS19

## 10. WHEN TRAVEL SPEED 1, 2 DOES NOT OPERATE

- Before disconnecting the connector, always turn the starting switch OFF.
- Before carrying out below procedure, check all the related connectors are properly inserted and short of fuse No.16.
- After checking, insert the disconnected connectors again immediately unless otherwise specified.

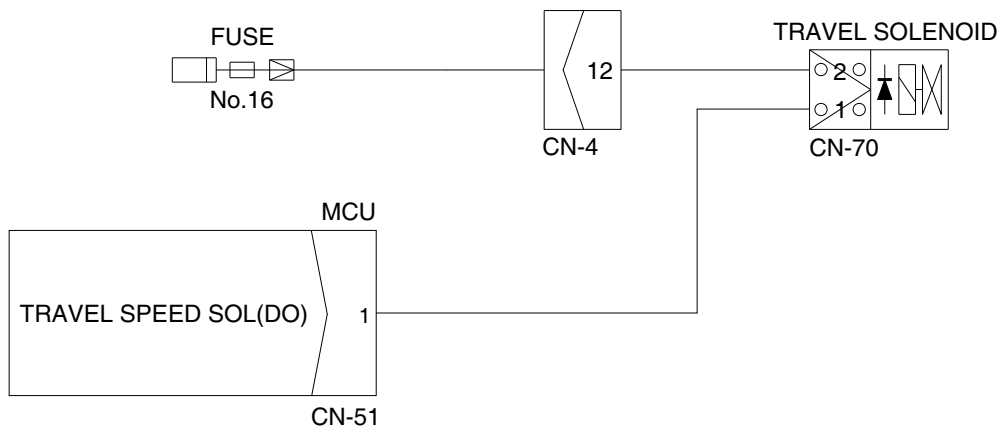
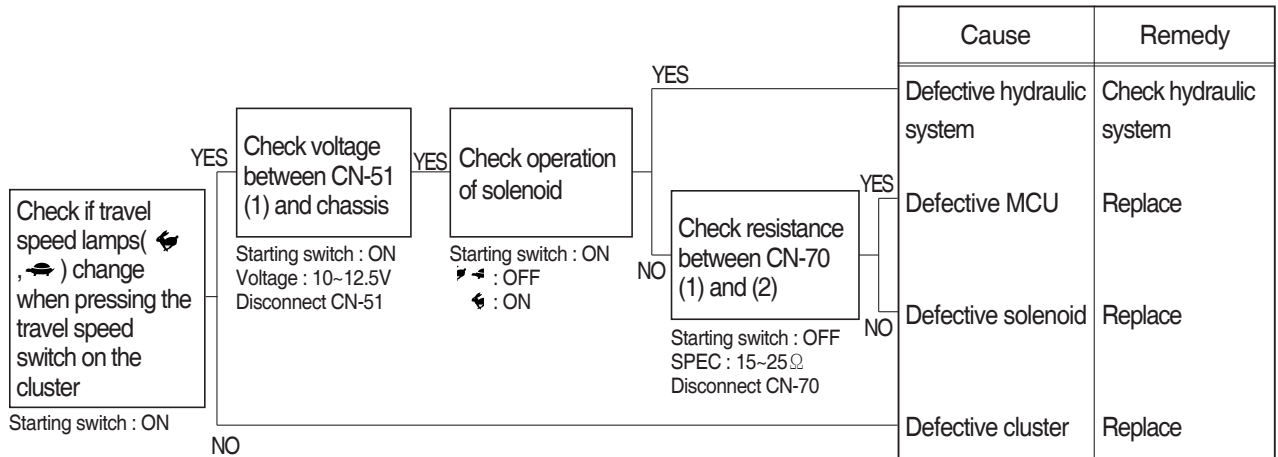

65A5TS20

## 11. WHEN STARTING SWITCH IS TURNED ON, WIPER MOTOR DOES NOT OPERATE

- Before disconnecting the connector, always turn the starting switch OFF.
- Before carrying out below procedure, check all the related connectors are properly inserted and the fuse No.14 is not blown out.
- After checking, insert the disconnected connectors again immediately unless otherwise specified.

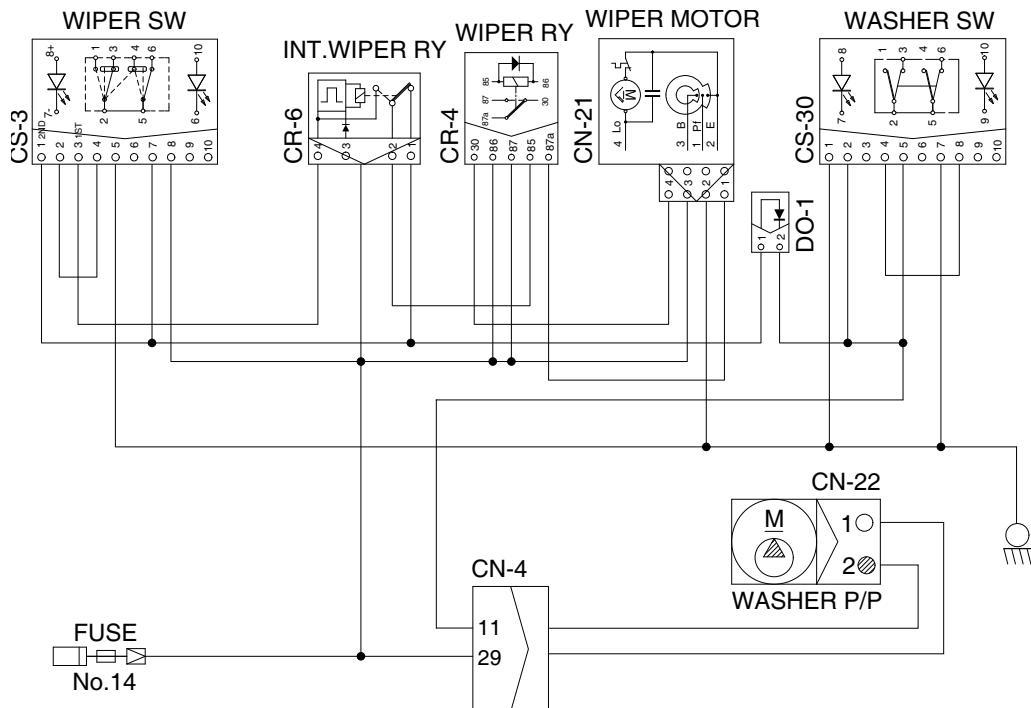
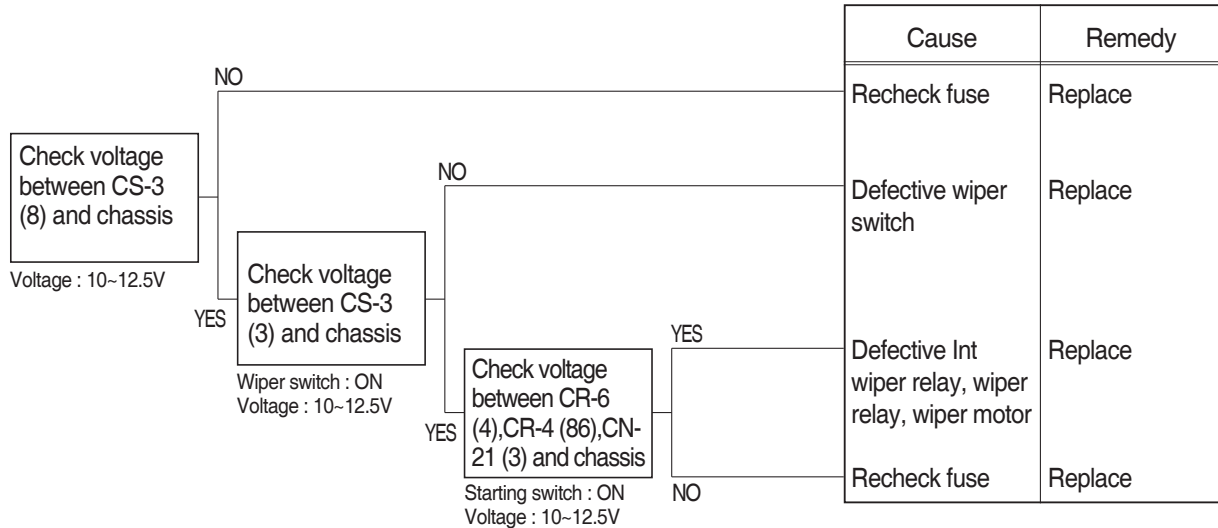

65A5TS21

## 12. WHEN STARTING SWITCH IS TURNED ON, HEAD LAMP DOES NOT LIGHTS UP

- Before disconnecting the connector, always turn the starting switch OFF.
- Before carrying out below procedure, check all the related connectors are properly inserted and short of fuse No.7, 11.
- After checking, insert the disconnected connectors again immediately unless otherwise specified.

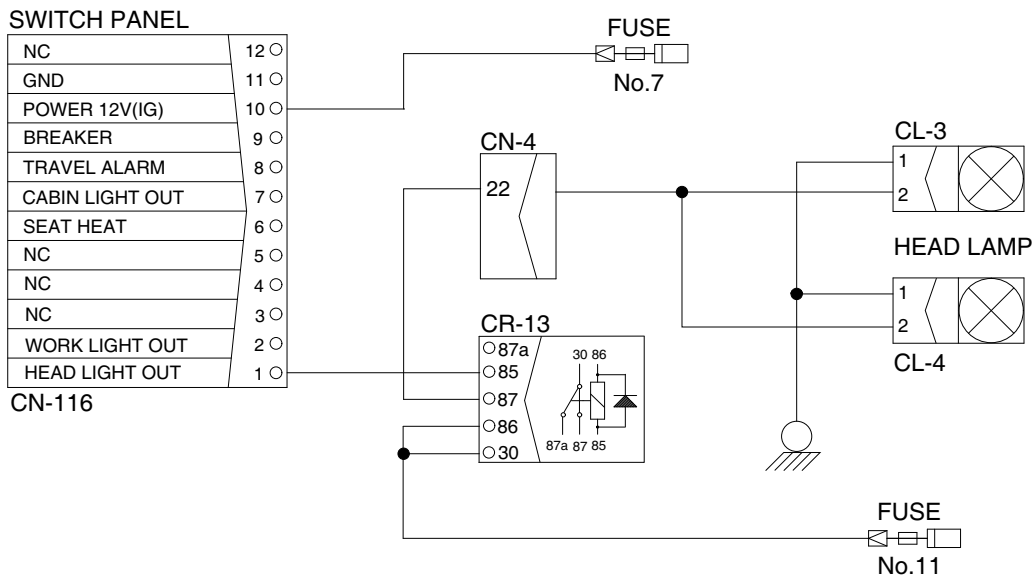
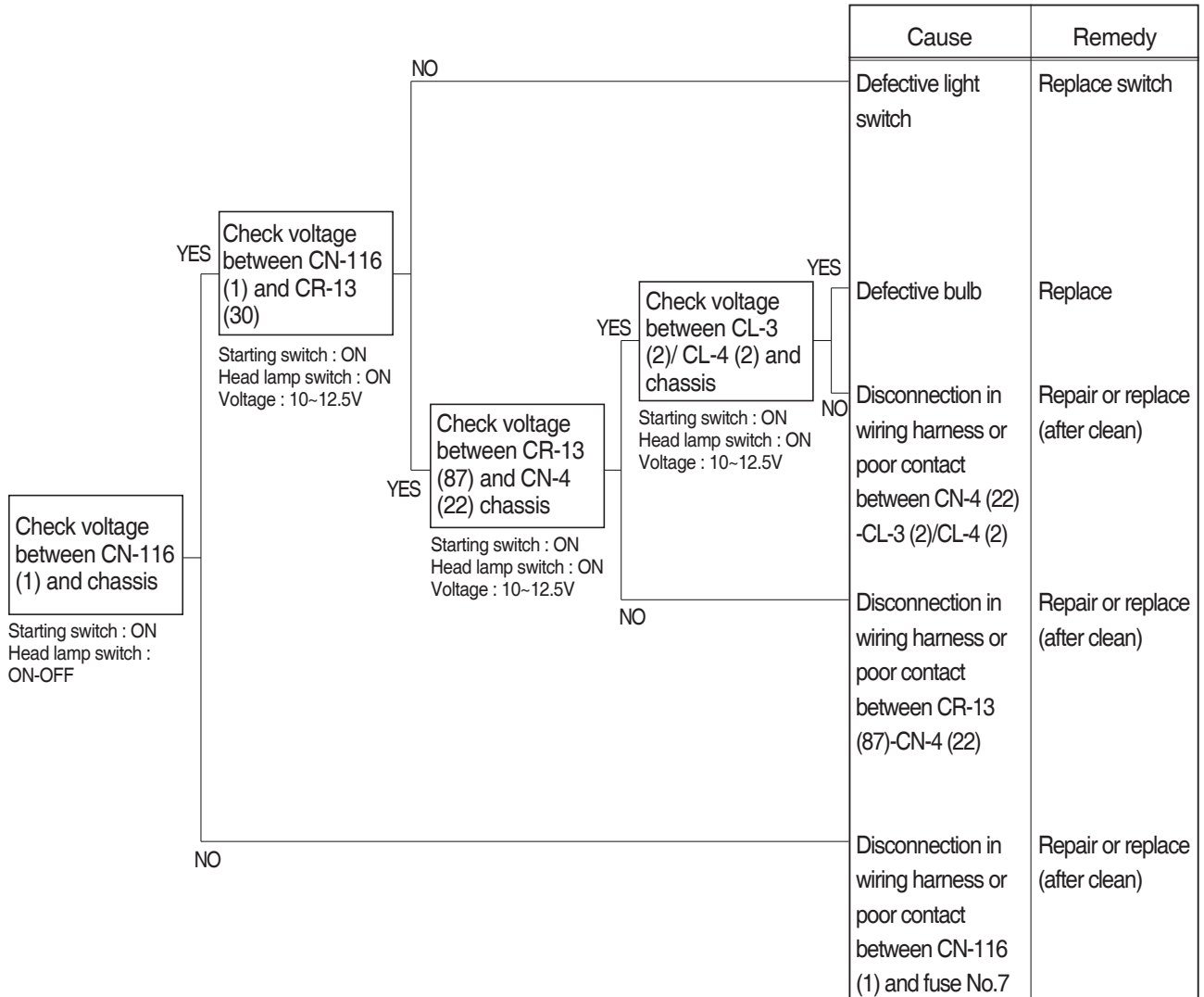

65A5TS22

### 13. WHEN STARTING SWITCH IS TURNED ON, WORK LAMP DOES NOT LIGHTS UP

- Before disconnecting the connector, always turn the starting switch OFF.
- Before carrying out below procedure, check all the related connectors are properly inserted and short of fuse No. 7, 12.
- After checking, insert the disconnected connectors again immediately unless otherwise specified.

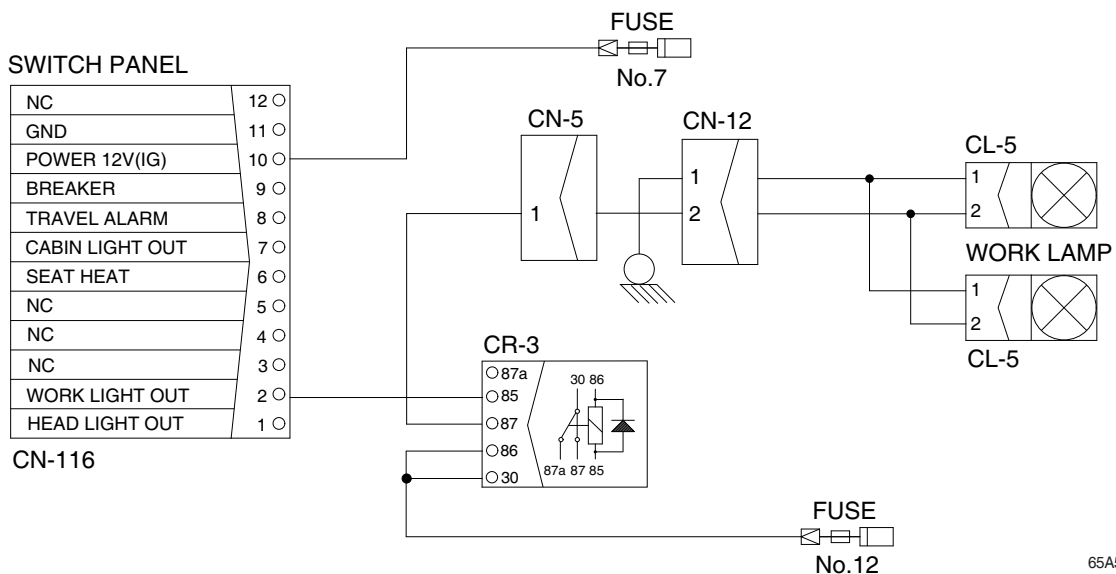
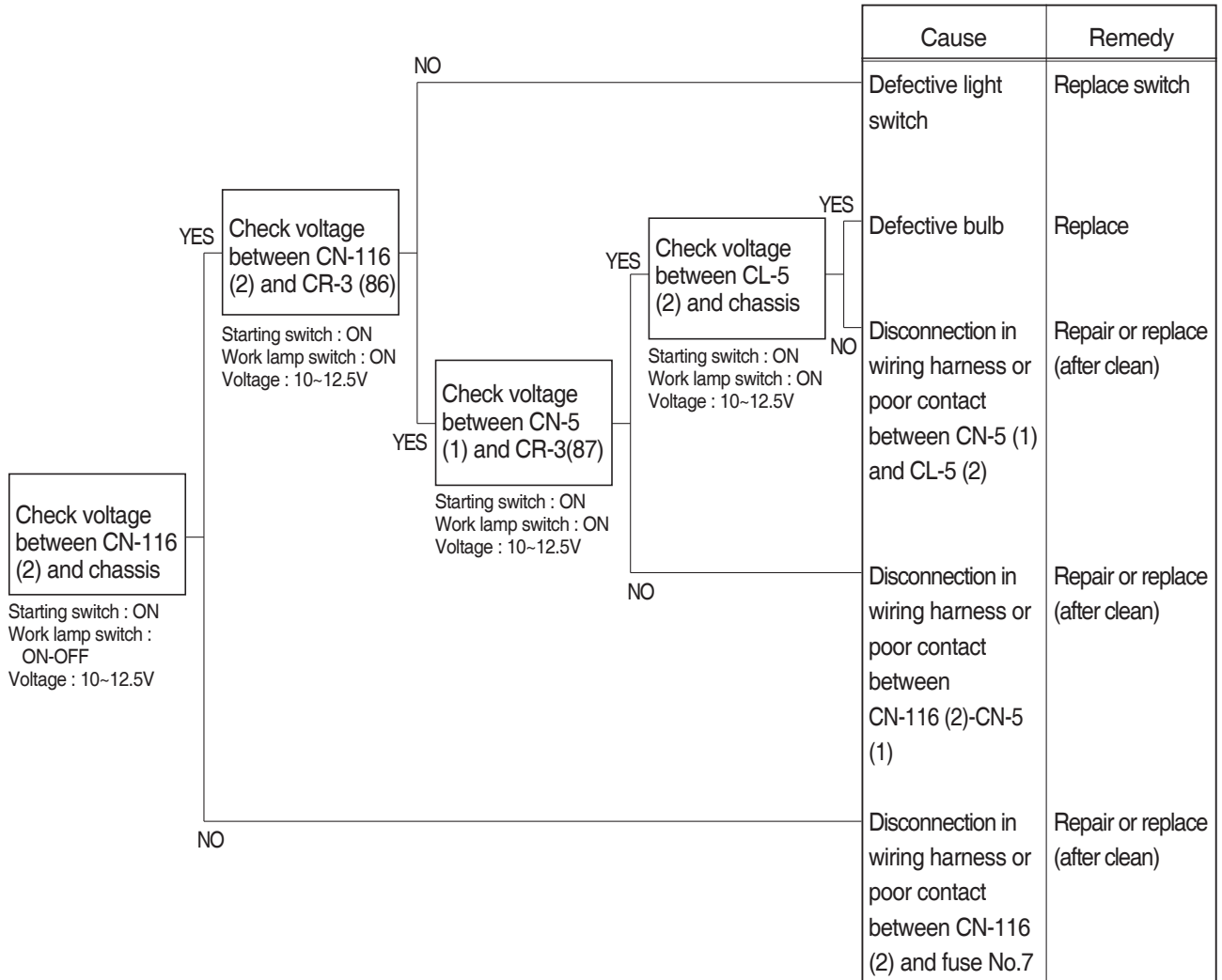

65A5TS23

## 14. WHEN ENGINE DOES NOT START

- Check supply of the power at engine stop solenoid while starting switch is ON.
- Before disconnecting the connector, always turn the starting switch OFF.
- Before carrying out below procedure, check all the related connectors are properly inserted.
- After checking, insert the disconnected connectors again immediately unless otherwise specified.

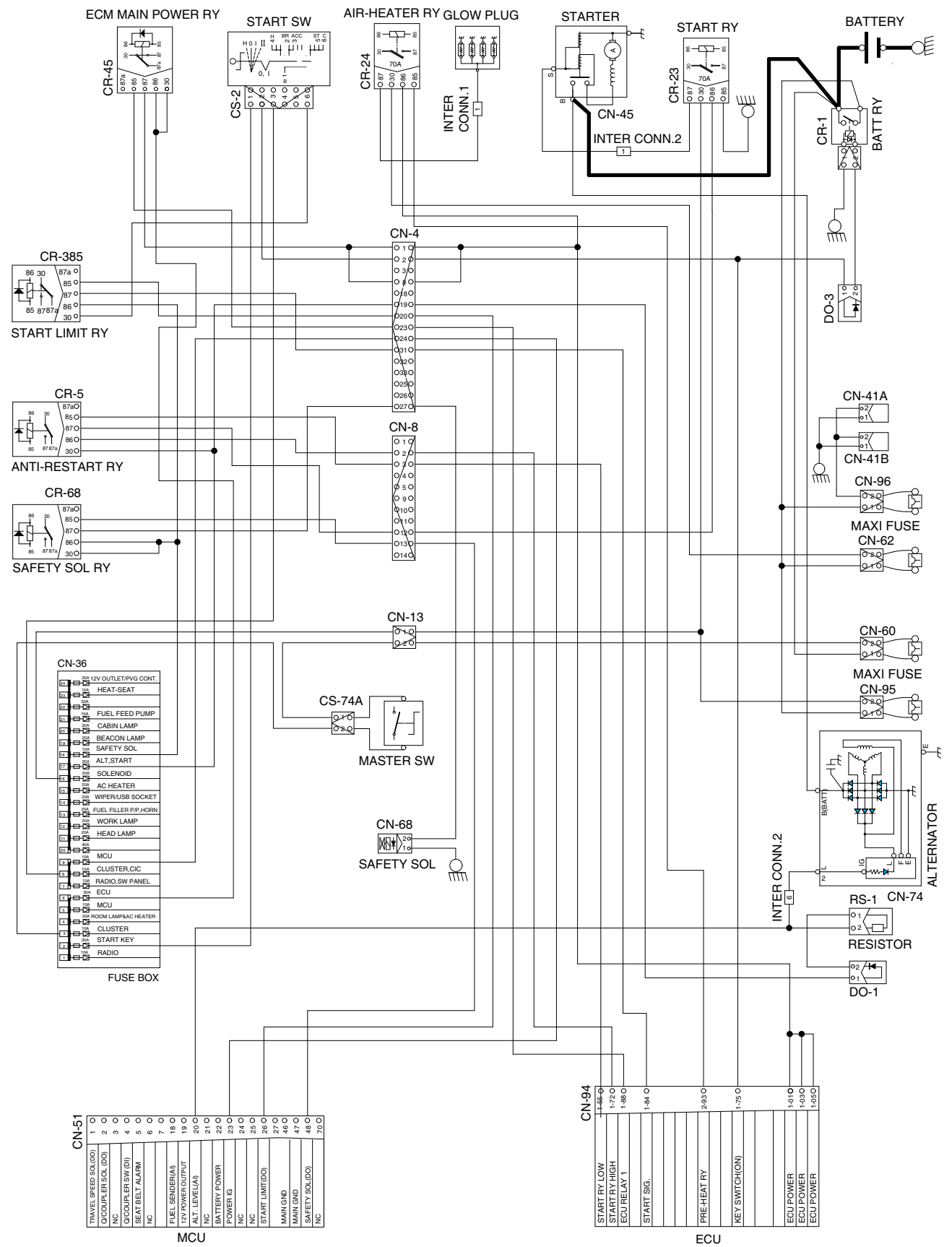
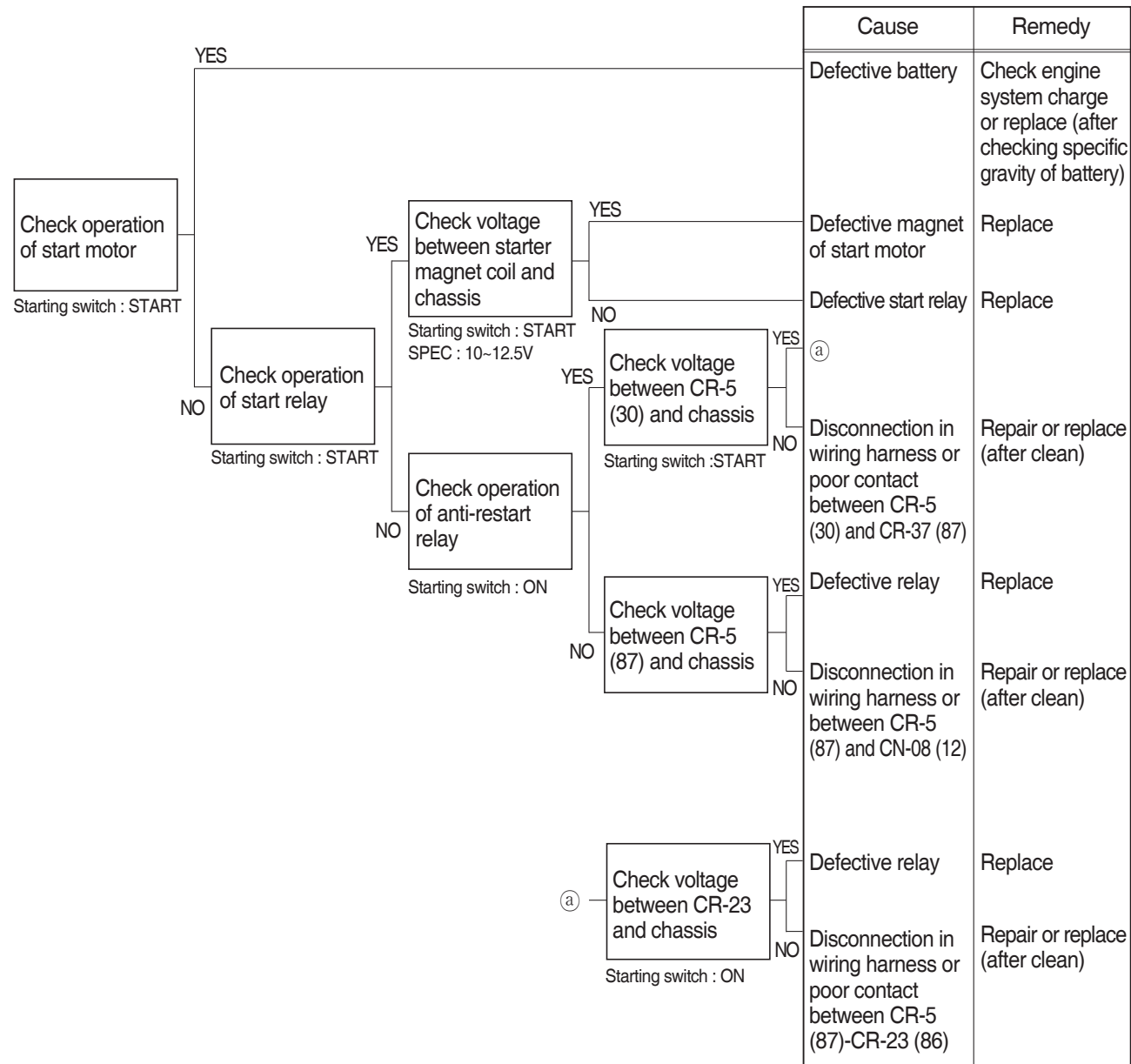

## 15. WHEN STARTING SWITCH ON DOES NOT OPERATE

- Before disconnecting the connector, always turn the starting switch OFF.
- Before carrying out below procedure, check all the related connectors are properly inserted and master switch ON.
- After checking, insert the disconnected connectors again immediately unless otherwise specified.

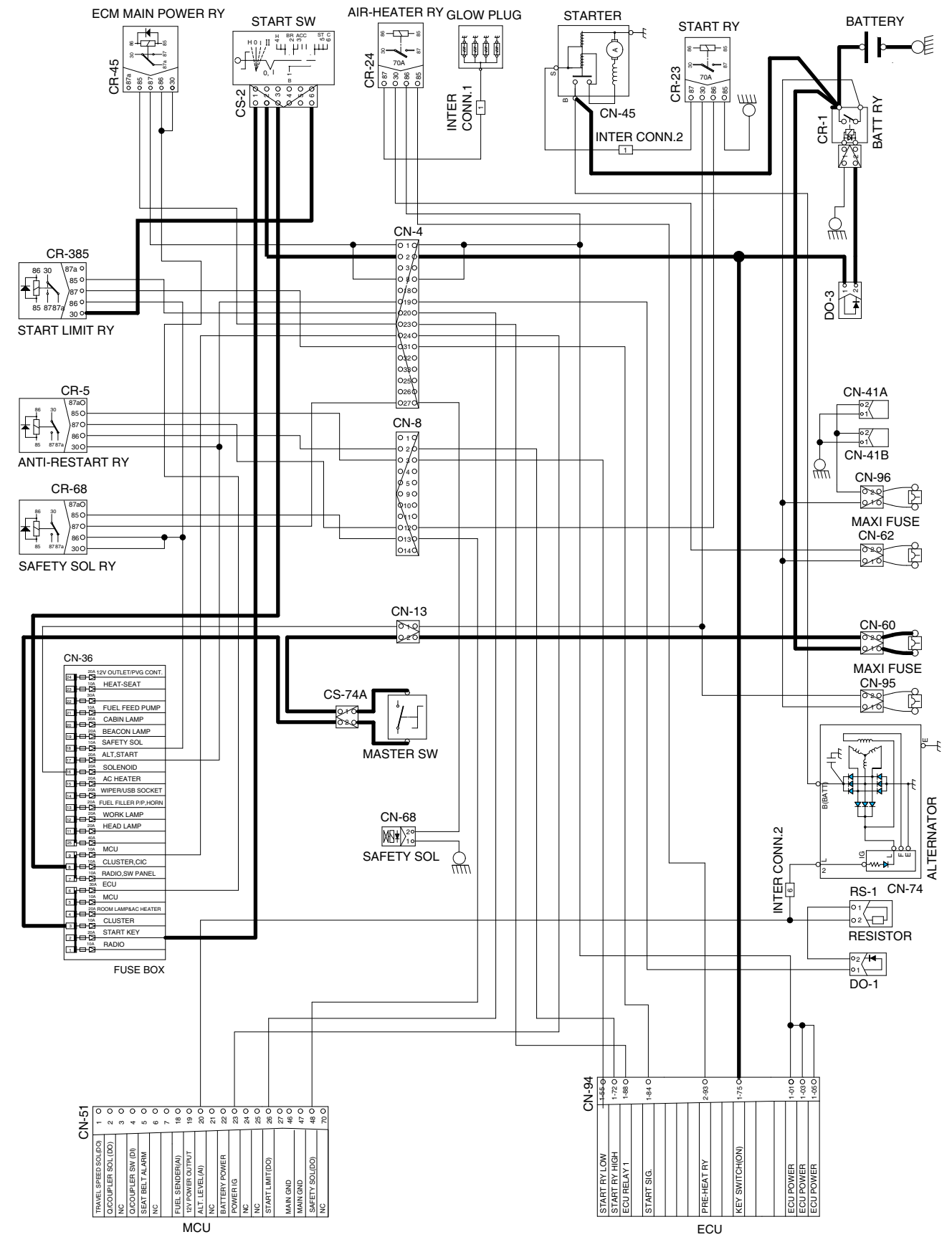
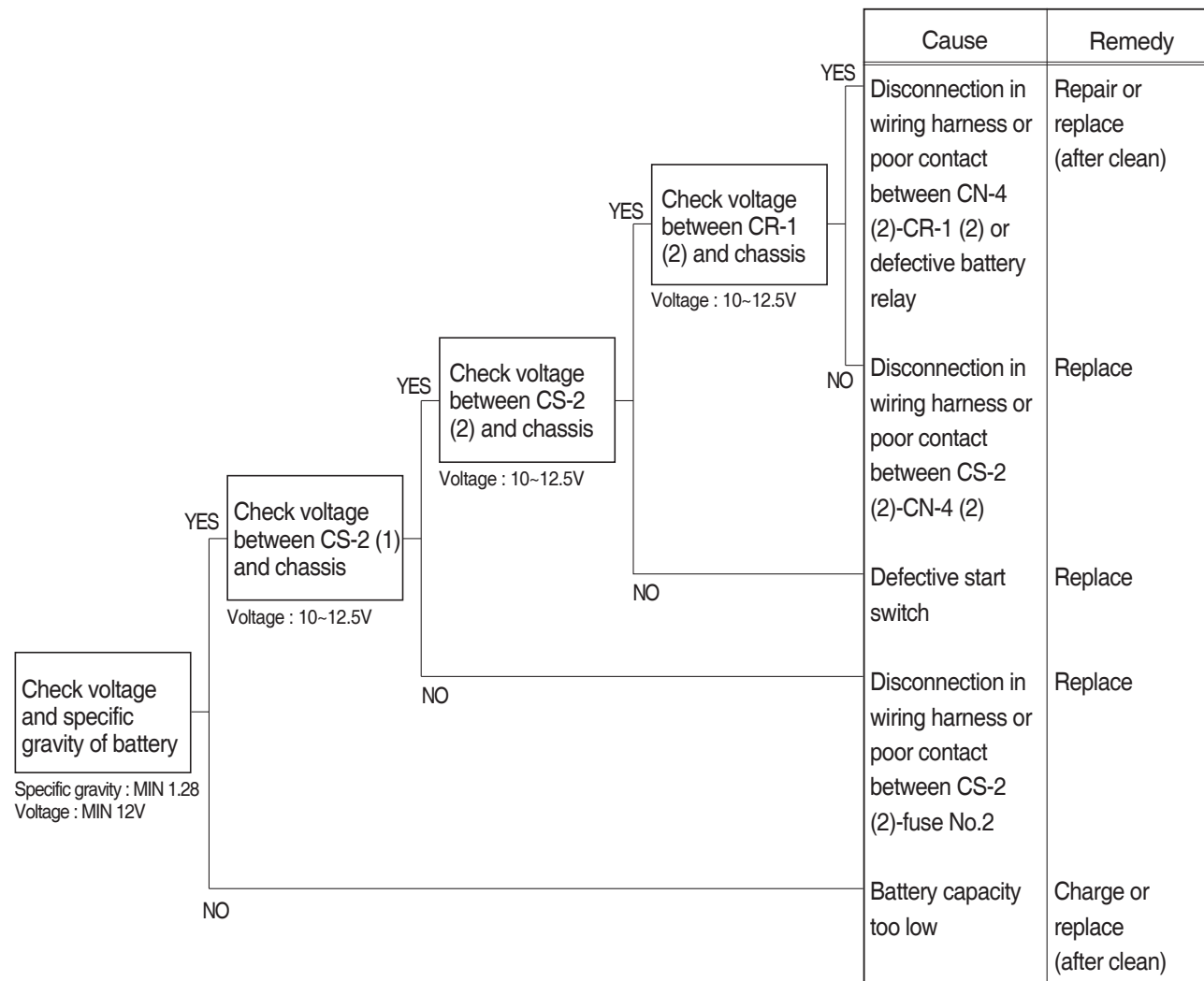

## GROUP 4 AIR CONDITIONER AND HEATER SYSTEM

### 1. AIR CONDITIONER DOES NOT OPERATE

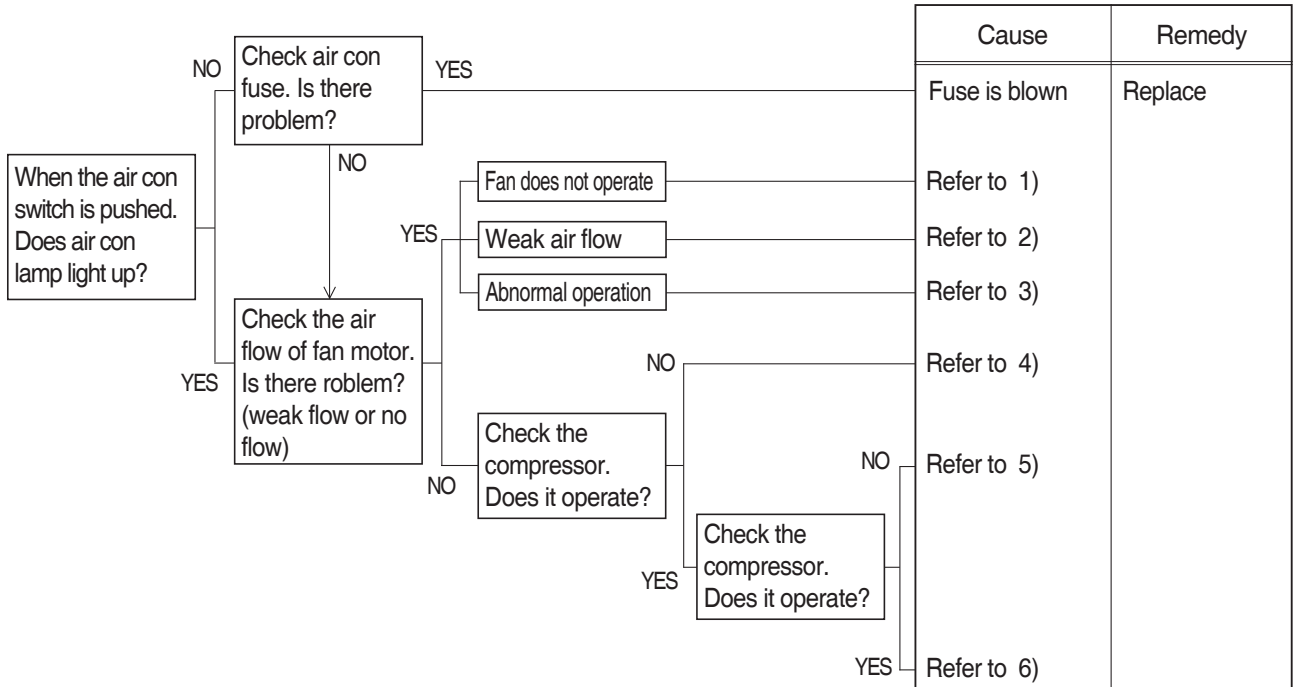

#### 1) FAN DOES NOT OPERATE

Cause	Check	Remedy
Fuse is blown or abnormal relay operation	* Fuse * Does relay normally operate?	Replace
Harness short or poor contact	Check any harness short or abnormal contact of connector	Repair shortage
Fan motor failure	Supply 24V to 2 lead wire from motor and check the operation	Replace
Resistor is broken	Check current flow of resistor with tester	Replace
Fan switch failure	Push fan switch by turn and check the operation	Replace



## 2) WEAK AIR FLOW FROM FAN MOTOR

Cause	Check	Remedy
Clogged evaporator or obstacles around air inlet	Check if evaporator is contaminated	Clean
Leakage of air flow	Check HVAC case assembly	Adjust
Duct sensor failure	Check if evaporator is frozen	Replace

## 3) ABNORMAL OPERATION OF FAN MOTOR

Cause	Check	Remedy
Abnormal operation of each step of control	4 step only operate	Replace resistor
	1 or 2 step does not operate	Replace control
	3 or 4 step does not operate	Replace relay

## 4) COMPRESSOR DOES NOT ROTATE OR HARDLY ROTATE

Cause	Check	Remedy
Loose belt	Belt shaking is severe	Adjust tension
Failure of compressor itself	Belt slip	Repair or Replace
Low voltage of battery	Slip when rotate	Charge battery
Fieldcoil short	Slip when rotate	Replace magnetic clutch
Oily clutch face	Contamination around clutch	Replace magnetic clutch, clean
Fieldcoil is broken	Magnetic clutch does not operate or " $\infty$ " resistance	Replace compressor
Leakage of refrigerant or oil inside	Check if wet with oil	Replace compressor Charge refrigerant

**5) COMPRESSOR OPERATE NORMALLY AND AIR FLOW IS NORMAL**

Cause	Check	Remedy
Shortage of refrigerant	When air con operate during 5~10 min small temperature difference between high and low pressure pipes.	Repair leakage joint Charge refrigerant
Overcharge of refrigerant	*Magnetic clutch on/off rapidly *High pressure over specification *Lukewarm air from nozzle	Recharge refrigerant following specification
Lower pressure than normal condition at low side	Shortage of refrigerant	Make up refrigerant
	Clogged receive dryer	Replace receive dryer
	Clogged expansion valve	Replace expansion valve
	Clogged or crushed pipe	Replace pipe or clean
	Failure of duct sensor	Replace duct sensor

**6) COMPRESSOR OPERATE NORMALLY AND AIR FLOW IS NORMAL**

Cause	Check	Remedy
Lower pressure than normal condition at low side	Failure of duct sensor Magnetic clutch off before air temperature sufficiently down	Replace duct sensor or adjust location
	Defective compressor gasket When compressor off, high and low pressure balance immediatly	Repair compressor or Replace
Higher pressure than normal condition at high side	Failure of condensing Contamination on condenser or insufficient air flow from fan	Clean the condenser Repair fan
	Overcharge of refrigerant	Adjust refrigerant
	Entrained air	Vacuum and recharge
Lower pressure than normal condition at high side	Shortage of refrigerant	Make up refrigerant