

SECTION 4 ELECTRICAL SYSTEM

Group 1 Component Location	4-1
Group 2 Monitoring system	4-3
Group 3 Electrical Circuit	4-38
Group 4 Electrical Component Specification	4-56
Group 5 Connectors	4-64
Group 6 Fault codes	4-82

GROUP 1 COMPONENT LOCATION

1. LOCATION 1

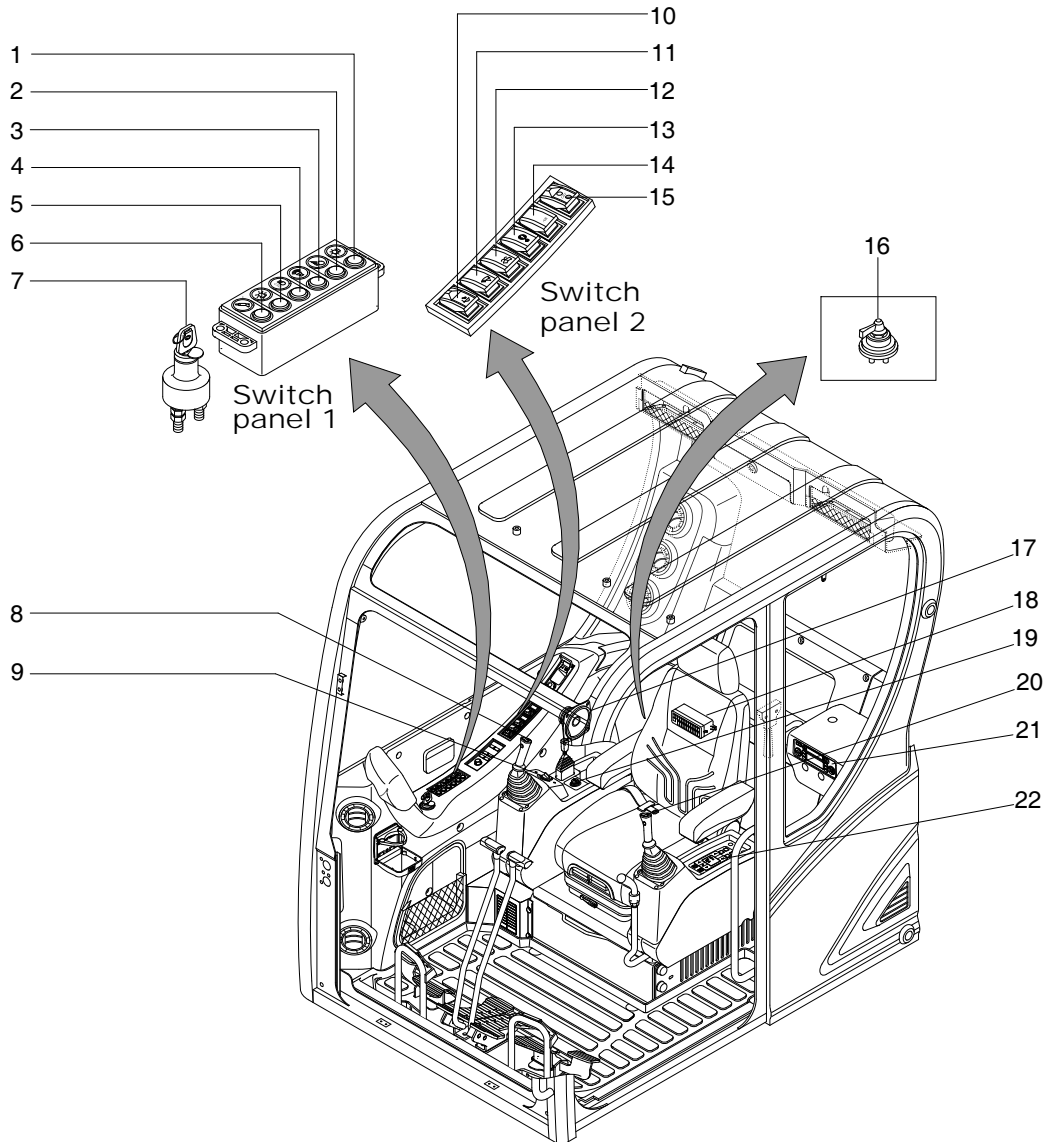

HX65A4EL01

- | | | |
|----------------------------------|----------------------------------|-------------------------------|
| 1 Head light switch | 8 Breaker operation switch (opt) | 15 Master switch |
| 2 Work light switch | 9 Accel dial switch | 16 Travel straight switch |
| 3 Travel alarm switch | 10 Quick clamp switch | 17 Horn switch |
| 4 Cab light switch | 11 DPF switch | 18 Aircon & heater controller |
| 5 Beacon switch (opt) | 12 Wiper switch | 19 Radio & USB player |
| 6 Breaker selection switch (opt) | 13 Washer switch | 20 Fuse box |
| 7 Start switch | 14 Overload switch (opt) | 21 Service meter |

2. LOCATION 2

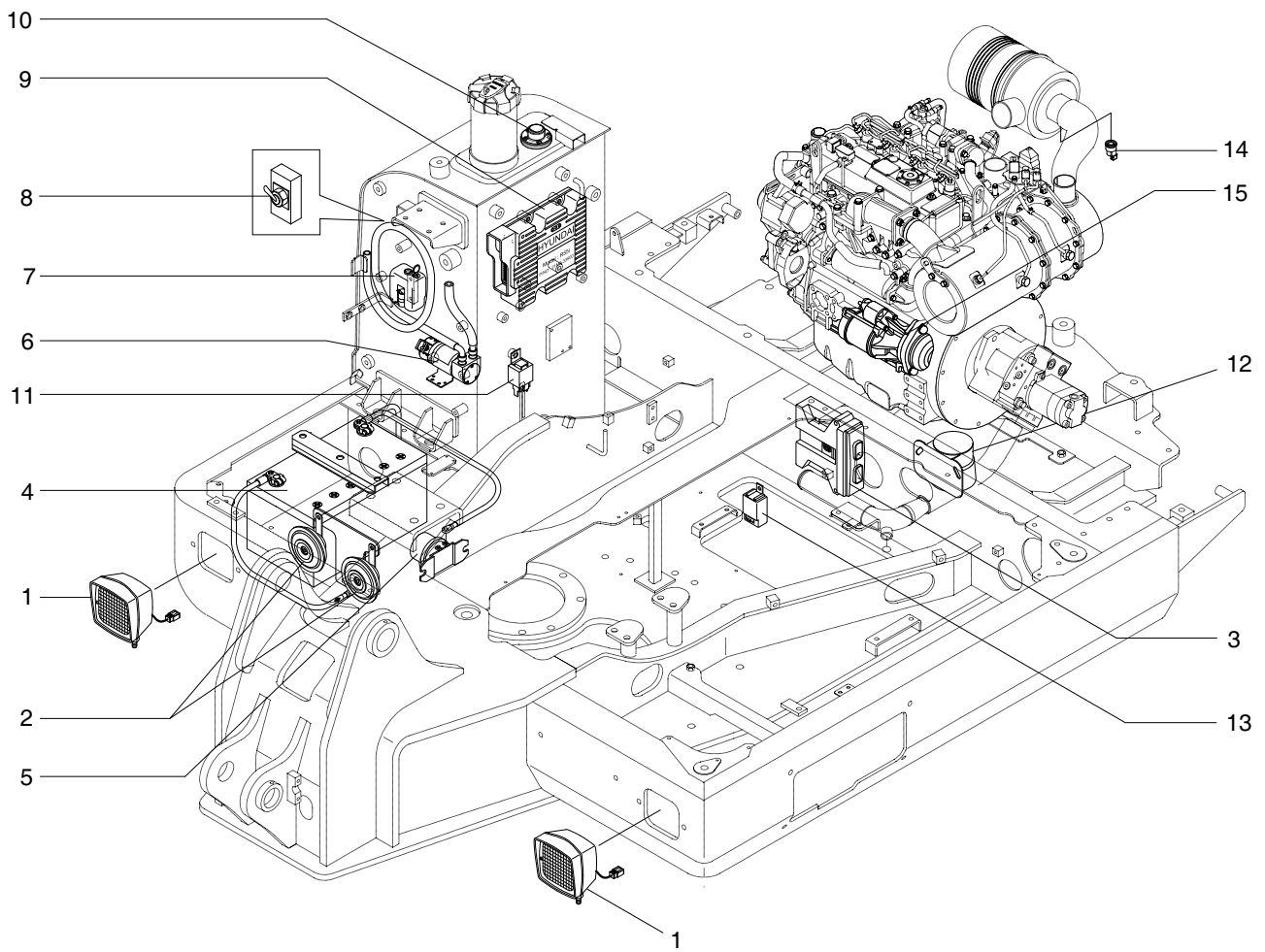

HX65A4EL02

- | | | | | | |
|---|----------------|----|---------------------------|----|---------------------|
| 1 | Work lamp | 6 | Fuel filler pump | 11 | Power relay |
| 2 | Horn | 7 | Washer tank assy | 12 | Travel alarm buzzer |
| 3 | PVG controller | 8 | Filler pump toggle switch | 13 | Warning buzzer |
| 4 | Battery | 9 | MCU | 14 | Air cleaner switch |
| 5 | Battery relay | 10 | Fuel sender | 15 | Alternator |

GROUP 2 MONITORING SYSTEM

1) STRUCTURE

The cluster consists of LCD and switches as shown below. The LCD is to warn the operator in case of abnormal machine operation or conditions for the appropriate operation and inspection.

Also, The LCD is to set and display for modes, monitoring and utilities with the switches.

The switches or touch screen are to set the machine operation modes.

- ※ The cluster installed on this machine does not entirely guarantee the condition of the machine. Daily inspection should be performed according to chapter 6, Maintenance.
- ※ When the cluster provides a warning immediately check the problem, and perform the required action.

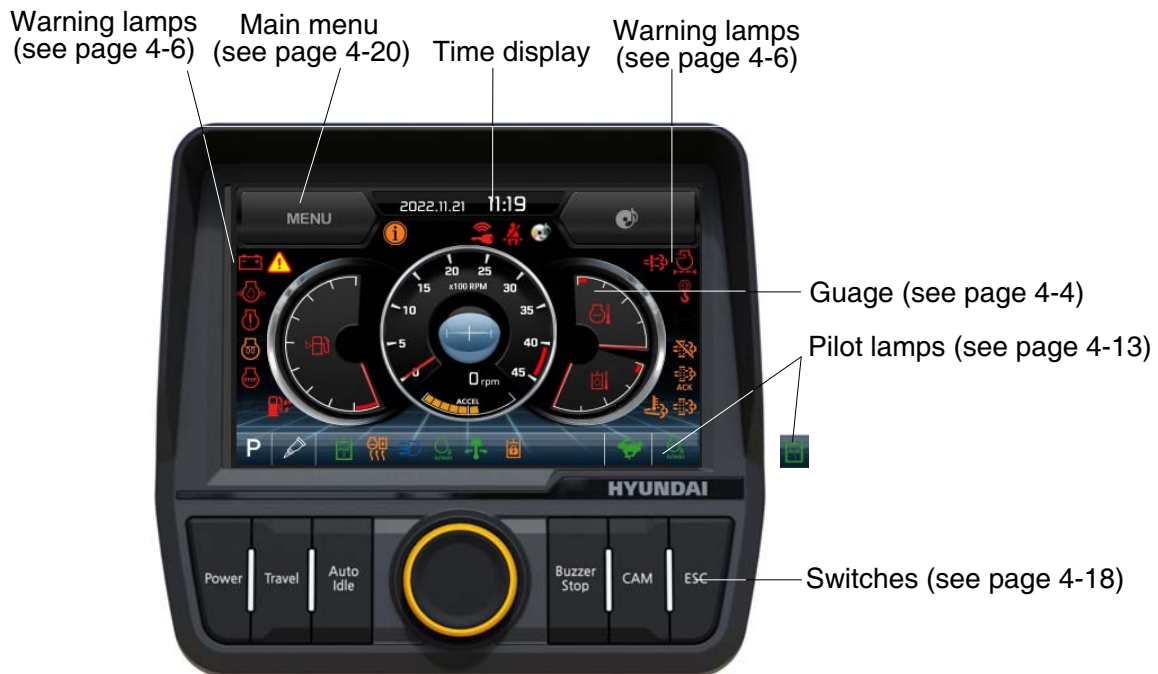

HX65A4CD01

- ※ The warning lamp pops up, lights ON (on the left-top side) and the buzzer sounds when the machine has a problem.

The warning lamp lights ON until the problem is cleared. Refer to page 4-6 for details.

2) GAUGE

(1) Operation screen

When you first turn starting switch ON, the operation screen will appear.





HX60A3CD101A

- | | | |
|-----------------------------|--------------------|--------------|
| 1 Engine coolant temp gauge | 3 Fuel level gauge | 5 Accel dial |
| 2 Hydraulic oil temp gauge | 4 Engine rpm gauge | 6 Clinometer |

(2) Engine coolant temperature gauge





290F3CD53

- ① This gauge indicates the temperature of coolant.
 - Black range : General state
 - Red range : Engine overheated state
 - ② If the indicator is in the red range or  lamp lights ON in red, turn OFF the engine and check the engine cooling system.
- ※ If the gauge indicates the red range or  lamp lights ON even though the machine is in the normal condition range, check the electric device as this can be caused by poor connection of sensor or connector, and poor grounding of the instrument, etc.

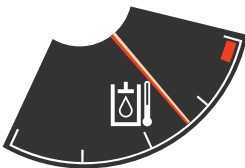
(3) Hydraulic oil temperature gauge





290F3CD54

- ① This gauge indicates the temperature of hydraulic oil.
 - Black range : 40-105°C (104-221°F)
 - Red range : Above 105°C (221°F)
 - ② If the indicator is in the red range or  lamp lights ON in red, reduce the load on the system. If the gauge stays in the red range, stop the machine and check the cause of the problem.
- ※ If the gauge indicates the red range or  lamp lights ON in red even though the machine is in the normal condition range, check the electric device as this can be caused by poor connection of sensor.

(4) Fuel level gauge



HX60A3CD55A

- ① This gauge indicates the amount of fuel in the fuel tank.
 - Black range : 9% or more
 - Red range : below 9%
 - ② Fill the fuel when in the red range, or  lamp lights ON in red.
- ※ If the gauge indicates the red range or  lamp lights ON in red even though the machine is in the normal condition range, check the electric device as this can be caused by poor connection of sensor.

(5) Engine rpm gauge and clinometer

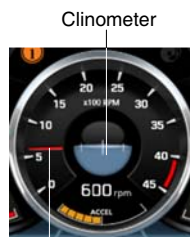

Engine rpm

HX60A3CD105K

- ① This displays the engine speed.
- ② This displays the tilt of machine.

(6) Accel dial gauge



290F3CD59

- ① This gauge indicates the level of accel dial from 0 to 10 step.

3) COMMUNICATION ERROR AND LOW VOLTAGE WARNING POP-UP

(1) Communication error pop-up



HX60A3CD107A

- ① Cluster displays this communication error pop-up when it has communication error with MCU.
- ② Communication error pop-up displays at operation screen only. Just buzzer alarm at the other screen.
- ③ If communication with MCU become normal state, it will disappear automatically.

(2) Low voltage warning pop-up



HX60A3CD108

- ① Cluster displays this low voltage warning pop-up when the battery voltage is low.
- ② Low voltage warning pop-up displays at operation screen only. Just buzzer alarm at the other screen.
- ③ This pop-up will disappear with using touch screen or buzzer stop switch. While the battery voltage is low, buzzer sounds every minute.
- ④ When the battery voltage is higher than 11.5 V, the pop-up off.

4) WARNING LAMPS



65A3CD109A

※ Each warning lamp on the left-top of the LCD pops up on the center of LCD and the buzzer sounds when the each warning is happened. The pop-up warning lamp moves to the original position and lights up when the buzzer stop switch is pushed or the pop-up is touched. And the buzzer stops. Refer to page 3-17 for the switch.

(1) Engine coolant temperature warning lamp



290F3CD61

- ① The warning light is turned ON and buzzer is sounded when the engine coolant temperature is overheated.
- ② The engine speed is also decreased unless the coolant temperature is reduced again. Here, do not turn OFF the engine. When the engine is turned OFF, the coolant temperature is overheated even more to cause engine rattle due to the surge.

※ Check the temperature gauge of the engine coolant. The coolant is overheated when the gauge in the red range. Here, the coolant temperature warning lamp is turned ON, and the engine speed is decreased automatically.

The engine performs ‘low-speed idle’ run until the gauge is returned to the black range. Even when the gauge returns to the black range, do not turn OFF the engine, and perform idle run additionally for 3~5 min. Ignoring this may cause surge from the heat to result in damage to the engine.



The reason for idle run of the engine is to disperse the overheated heat slowly to reduce the temperature.

After proper measures are finished check the coolant level again, and inspect whether the fan belt is loose, and whether there are any foreign substances around the radiator. When the coolant temperature returns to normal temperature, the engine speed is restored to normal speed again.

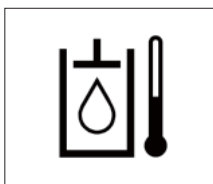
(2) Hydraulic oil temperature warning lamp



290F3CD62

- ① This warning lamp pops up on the center of LCD and the buzzer sounds when the hydraulic oil temperature is over 105°C.
- ② The pop-up  lamp moves to the original position and lights ON when the buzzer stop switch is pushed or pop-up is touched. Also, the buzzer stops and  lamp keeps ON.
- ③ Check the hydraulic oil level and hydraulic oil cooling system.

(3) Fuel level warning lamp

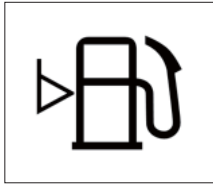

290F3CD63

- ① This warning lamp lights up and the buzzer sounds when the level of fuel is below 9%.
- ② Fill the fuel immediately when the lamp is ON.

(4) Emergency warning lamp



290F3CD64

- ① This warning lamp pops up and the buzzer sounds when each of the below warnings occurs.
 - MCU input voltage abnormal
 - Accel dial circuit abnormal or open
- ※ **The pop-up warning lamp moves to the original position and lights ON when the buzzer stop switch is pushed or pop-up is touched. Also the buzzer will stop. This is same as following warning lamps.**
- ② When this warning lamp lights up, machine must be checked and serviced immediately.

(5) Engine oil pressure warning lamp



290F3CD65

- ① This warning lamp lights up when the engine oil pressure is low.
- ② If the lamp lights up, shut off the engine immediately. Check oil level.
- ※ **Serious damage can be caused to the engine when the engine is operated continuously while the warning lamp is turned ON.**

(6) Check engine warning lamp

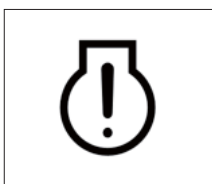

290F3CD66

- ① Warning lamp is turned ON when the engine must be checked.
- ※ **When the warning lamp is turned ON, stop the machine and find the cause for repair.**

(7) Battery charging warning lamp

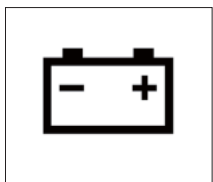

290F3CD67

- ① This warning lamp lights up when the battery charging voltage is low.
- ② Check the battery charging circuit when this lamp lights up.

(8) Air cleaner warning lamp

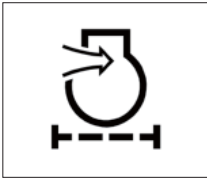

290F3CD68

- ① This warning lamp lights up when the air cleaner is clogged.
- ② Check, clean or replace the filter.

(9) Overload warning lamp (opt)

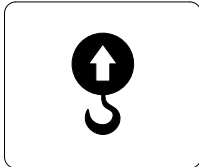

21093CD36

- ① When the machine is overloaded, the overload warning lamp lights up when the overload switch is ON. (if equipped)
- ② Reduce the machine load.
Initiate a manual regeneration

(10) DPF (Diesel Particulate Filter) Warning Lamp

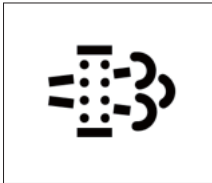

290F3CD70

- ① This lamp is turned ON or OFF to inform that regeneration is required.
- ② For details, please refer to the after-treatment system below.

※ After-treatment System

The after-treatment system uses DOG and DPF to satisfy the exhaust regulations.

The oxidation catalyst of DOG reduces the emission of hydrocarbon and carbon monoxide through the catalyst, and the particle materials (PM) discharged from the engine are collected.

DPF regeneration is composed of “forced regeneration” during driving and “manual regeneration” performed by the driver.

When the regeneration is not performed successfully according to the procedure, warning lamp relevant to the each operating condition is turned ON.

When the warning lamp is turned ON, park the machine on a safe place, and perform the regeneration process manually according to the following procedure.



The warning lamp is turned OFF when the regeneration process is performed successfully.

DPF regeneration mode is classified into the following stages according to the soot accumulation level on the DPF.

- Soot level of 80% or less : Normal operating condition
- Soot level of 80~100% : AUTO regeneration during driving
- Soot level of 100~120% : Regeneration initiated by the driver (Manual Regeneration)
- Soot level of 120% or more : Inquiry to the Service Center or agent required
(DPF warning lamp turned OFF, check engine warning lamp turned ON, engine power reduced)

▲ Engine power can be reduced when the regeneration process is not performed manually after the warning lamp is turned ON.

※ DPF Regeneration Procedure

Procedure	Soot Amount	DPF Warning Lamp 	Check engine warning lamp 	Decrease in Torque	Remark
1	Less than 99%	-	-	-	No action (Manual regeneration according to the equipment)
2	100~105%	-	-	-	Regeneration is started. Performed in high temperature (560~640°C)
3	106~110%	Blinking slowly	-	-	Forced regeneration induced (Alarm)
4	111~120%	Blinking slowly	Turned ON	Torque reduced weakly	Forced regeneration induced (Decrease in Torque)
5	121% or more	Blinking quickly	Blinking	Torque reduced severely	Regeneration is inactivated. Inquire to the service center or to the agent to start the service regeneration to solve the decrease in torque

- DPF warning lamp is turned ON when the DPF soot exceeds 100%.
- DPF warning lamp is blinked when the DPF soot level exceeds 105%.
- When the DPF soot level exceeds 111%, the DPF warning lamp blinks slowly, and the check engine warning lamp is turned ON to reduce the engine power.
- When the DPF soot level exceeds 121%, the DPF warning lamp blinks slowly, and the check engine warning lamp is turned ON to reduce the engine power.
- DPF regeneration is composed of the active regeneration occurred during driving and forced regeneration activated manually by the driver.
- When the DPF soot level is less than 105%, active regeneration is activated automatically during driving.
However, the system informs the driver to perform forced regeneration manually when the level is 105% or more.
The check engine warning lamp is turned ON when the level is 120% or more, and engine power is reduced to 50%. The driver must inquire to the service center or to the agent.
- DPF soot level of 105% or less : Active regeneration
- DPF soot level of 105~120% : Forced regeneration + Engine power reduced
- DPF soot level of 105~120% : Driver is informed that forced regeneration is required.
- DPF soot level of 120% or more : Regeneration not possible, and inquiry required to the service center or to the agent

※ Manual (Forced) DPF regeneration method

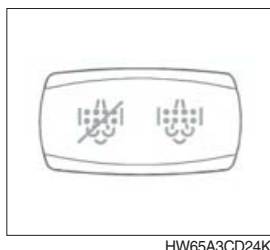

DPF regeneration procedure is activated manually by the driver when the driver selects to initiate the regeneration procedure.

Because the operating condition is inappropriate for the hot engine exhaust temperature (Ex.: Work near the inflammable materials), manual regeneration may be required if the driver prohibited the active regeneration procedure for long period.

① Manual regeneration condition

- Coolant (Engine oil) temperature : 40 °C or more
- Engine RPM: Low-speed idle run
- Parking brake must be applied (Only relevant to the wheel-type machine)
- When the soot concentration is accumulated to 20% or more

② Manual (Forced) regeneration procedure

Park the machine on a well-ventilated area, and keep away from inflammable materials to set the machine as shown below.

- Operate the machine until the engine coolant and oil temperature becomes 40°C or more.
- Engine speed is set to low speed.
- Put the gear lever on neutral, and apply the parking brake. (Only relevant to wheel-type machine)
- Safety lever is placed on the locking position.
- When the regeneration mode is in "Prohibit", DPF switch is pressed to the manual regeneration position.

③ Regeneration switch is activated to initiate the regeneration procedure.

※ DPF warning lamp is lighted on the monitor.

While the engine speed is in low speed, the speed is increased gradually to 2000 RPM, and the regeneration procedure is initiated.

Manual regeneration can be continued for maximum of 30 min. or more according to the soot accumulation amount.

HEST lamp is lighted during the regeneration, and HEST lamp is turned OFF when regeneration is stopped.

※ The driver can stop the manual regeneration by lifting the safety lever to the "Release Lock" position, or by pressing the DPF switch to the "Prohibit" position.

(11) Stop engine warning lamp

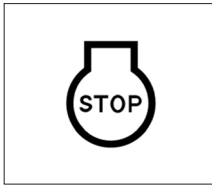

290F3CD252

- ① If this warning lamp lights up, stop the engine immediately and check the engine.
 - ② Check the fault codes on the monitor.
- ※ **Please contact your HD Hyundai Construction Equipment service center or local dealer.**

(12) Water in fuel warning lamp



HX60A3CD110

- ① This warning lamp lights up when the water separator is full of water or malfunctioning.
- ② When this lamp lights up, stop the machine and drain water from the water separator.

(13) Seat belt reminder warning lamp



300A3CD25

- ① When operator does not fasten the operator's seat belt, the seat belt reminder warning lamp pops up and the buzzer sounds.
- ② Fasten the seat belt.

(14) Exhaust System Failure Warning Lamp

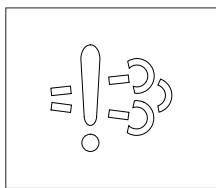

HW60A3CD53A

- ① This warning lamp is turned ON in 3 cases such as when the quantitative distribution is stopped, poor reagent quality and monitoring malfunction, etc.
- ② Please refer to the exhaust gas control system below.

※ Exhaust Gas Control System

This machine is equipped with the engine exhaust gas emission control system that satisfies the exhaust gas emission regulations. The owner/driver has the responsibility of proper operation and maintenance on the exhaust control system provided in the guaranteed provisions related to emission.

The engine exhaust system is mounted on the DPF. DPF is a emission reduction device that reduces the diesel particulate matter or soot from the exhaust gas of the diesel engine. DPF is stored until the particulate matter is combusted. The process of combustion and elimination of the stored particulate matter is referred to as "Regeneration". After the regeneration process is completed, residue is remaining, and it must be removed from the DPF regularly.

▲ The temperature of the exhaust gas and components of the exhaust system are in very high temperature during regeneration. There are risks of fire or burn, and it can also result in death, severe injury or property loss. Inflammable materials and explosive gas must be kept far away from the exhaust system during regeneration.





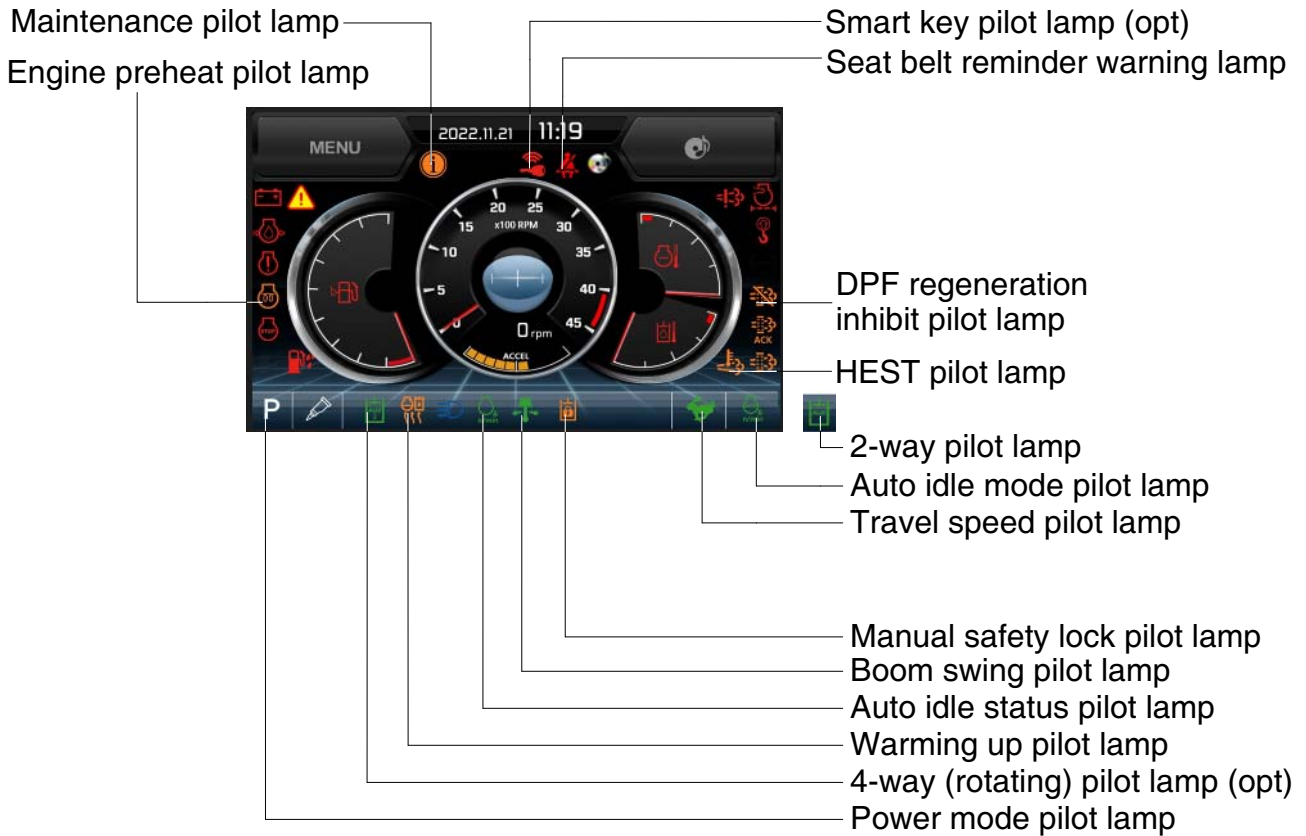

Item	Stage	Reducing Agent Level/Time	Notification Method	Decrease in Torque	Symbol
EGR Valve Problem	Warning	Immediately	Always	-	
	Level 1	+36 hours	Blinking slowly	Torque Limit : ~25%	
	Serious	+64 hours (100 hours)	Blinking quickly + Buzzer	Torque Limit : ~50% Speed Limit : 60%	

5) PILOT LAMPS



65A3CD112

(1) Mode pilot lamps

No	Mode	Pilot lamp	Selected mode
1	Power mode		Heavy duty power work mode
			Standard power mode
2	Travel mode		Low speed traveling
			High speed traveling
3	Auto idle mode		Auto idle mode
			Auto idle status

(2) Preheat pilot lamp

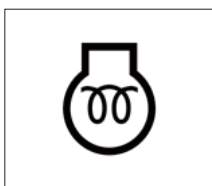

290F3CD79

- ① Turning the start key switch to the ON position starts preheating in cold weather.
 - ② Start the engine after this lamp goes OFF.
- ※ Refer to the operator's manual page 4-4.

(3) Warming up pilot lamp

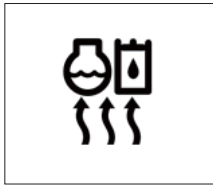

290F3CD80

- ① This lamp lights up when the coolant temperature is below 30°C (86°F).
- ② The automatic warming up is cancelled when the engine coolant temperature is above 30°C (86°F), or when 10 minutes have passed since starting the engine.

(4) Auto idle status/ mode pilot lamp

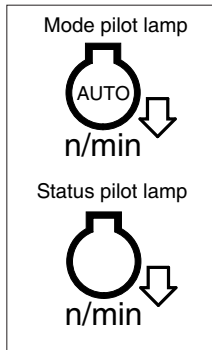

85A3CD106

- ① The auto idle mode pilot lamp will light up when the idle mode is selected.
- ② The auto idle status pilot lamp will be ON when all levers and pedals are in the neutral position, and the auto idle mode is selected.
- ③ One of the lever or pedal is operated, the status lamp will go OFF and the engine speed returns to the previous conditions.

(5) Maintenance pilot lamp



HX60A3CD116

- ① This lamp lights up when consumable parts are in need of replacement. It means that the change or replacement interval of parts is 30 hours from the required change interval.
- ② Check the message in maintenance information of main menu. Also, this lamp lights up for 3 minutes when the start switch is switched to the ON position.

※ Refer to page 4-20.

(6) Boom swing pilot lamp

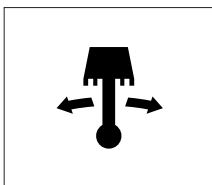

HX603CD82

- ① This lamp lights up when the boom offset switch is pressed.

※ Refer to the operator's manual page 3-44.

(7) DPF regeneration inhibit warning lamp

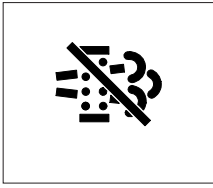

85A3CD107

- ① This warning lamp indicates, the DPF switch is pushed to the inhibit position, therefore automatic and manual regeneration can not occur.

※ Refer to the operator's manual page 3-40 for the DPF switch.

(8) HEST (High exhaust system temperature) warning lamp

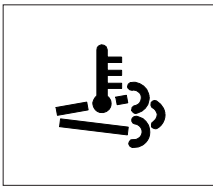

85A3CD109

- ① This warning lamp indicates, when illuminated, that exhaust temperatures are high due to regeneration of the DPF.
- ② The lamp will also illuminate during a manual regeneration.
- ③ When this lamp is illuminated, be sure the exhaust pipe outlet is not directed at any surface or material that can melt, burn, or explode.

▲ When this lamp is illuminated, the exhaust gas temperature could reach 600°C [1112°F], which is hot enough to ignite or melt common materials, and to burn people.

※ The lamp does not signify the need for any kind of equipment or engine service; It merely alerts the equipment operator to high exhaust temperatures. It is common for the lamp to illuminate on and off during normal equipment operation as the engine completes regeneration cycles.

(9) 4-way (rotating) pilot lamp (opt)

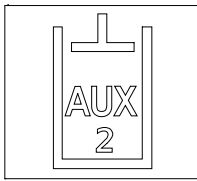

HW60A3CD48A

- ① This lamp lights up when the boom swing selection switch is set to the rotator (not used boom swing) and the 4-way operation switch on the LH control lever is pressed.

※ Refer to the operator's manual page 3-42.

(10) 2-way pilot lamp

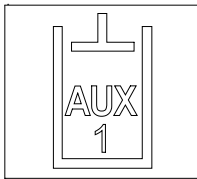

HW65A3CD49

- ① This lamp lights up when the option flow control function is activated in the cluster.

※ Refer to the page 4-24.

(11) Manual safety lock pilot lamp



140WA3CD37

① This lamp lights up when the safety knob is set to the LOCK position.

※ Refer to the operator's manual page 3-45 for the safety knob.

(12) Smart key pilot lamp (opt)



300A3CD36A

① This lamp lights up when the engine is started by the start button.

② This lamp is red when the authentication fails, it will be green when authentication is successful.

※ Refer to the page 4-28.

6) SWITCHES



65A3CD117A

※ When the switches are selected, the pilot lamps are displayed on the LCD. Refer to the page 4-13 for details.

(1) Power mode switch

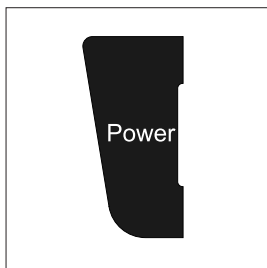

HX60A3CD118

- ① This switch is to select the machine power mode and when pressed, the power mode pilot lamp will be displayed on the section of the monitor.
 - P : Heavy duty power work.
 - S : Standard power work.
- ② The pilot lamp changes S → P → S in this order.

(2) Select switch

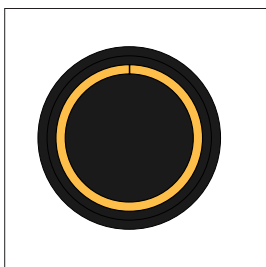

HX60A3CD119

- ① This switch is used to select or change the menu or input value.
- ② Knob push
 - Short (below 0.5 sec) : Select menu
- ③ Knob rotation

This knob changes menu and input value.

 - Right turning : Down direction / Increase input value
 - Left turning : Up direction / Decreased input value

(3) Auto idle switch

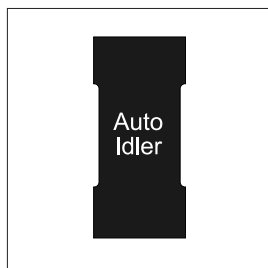

HX60A3CD120

- ① This switch is used to activate or cancel the auto idle function.
- ※ Refer to the page 4-13 for details.

(4) Buzzer stop switch

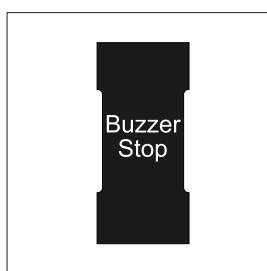

HX60A3CD121

- ① The buzzer sounds when the machine has a problem. In this case, push this switch and buzzer stops, but the warning lamp lights up until the problem is cleared.

(5) Camera switch

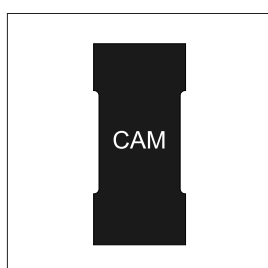

HX60A3CD122

- ① In the operation screen, pushing this switch will display the view of the camera on the machine (if equipped).
- ※ Please refer to page 4-35 for the camera.

(6) Escape switch

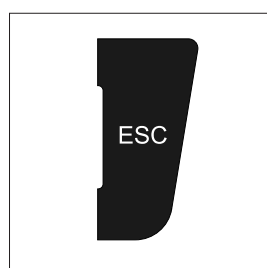



HX60A3CD123

- ① This switch is used to return to the previous menu or parent menu.

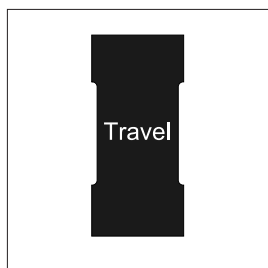
(7) Travel speed control switch



HX60A3CD104

- ① This switch is used to select the travel speed alternatively.
 -  : Low speed
 -  : High speed
- ※ Do not change the setting of the travel speed switch while machine is moving. Machine stability may be adversely affected.
- ⚠ Serious injury or death can result from sudden changes in machine stability.

7) MAIN MENU

Main menu screen



HX60A3CD124A



Sub menu screen



HW60AH3CD125A

- ※ Please refer to the select switch, page 4-18 for selection and change of menus and input values.
- ※ In the operation screen, tap MENU or press the select switch to access the sub-menu screen.

(1) Structure

No	Main menu	Sub menu	Description
1	 Monitoring	Active fault - Machine Active fault - Engine Logged fault - Machine/engine Delete logged fault Monitoring - Machine Monitoring - Switch Monitoring - Output	MCU ECU MCU, ECU MCU, ECU Engine rpm, oil temp, voltage and pressure etc. Digital switch status Digital output status
2	 Management	Maintenance information Option flow control ESL mode setting Change password Machine information A/S phone number Cluster update CAN update Service menu	Elapsed time, Change interval, Replacement etc. Opt atch set, Proportional flow control set, Confirmation ESL mode setting Password change Cluster, MCU, Engine, Machine A/S phone number, A/S phone number change Application, System Program download, Update Power shift, Operating hour, Gauge type, Rpm, AVCU set, Language update etc
3	 Display	Clock Brightness Unit Language	Current time set Manual, Auto Temperature, Pressure, Flow, Distance, Volumn 22 kinds
4	 Utilities	Entertainment Camera setting Clinometer setting Manual Emergency mode Quick cooling mode	Video/music file playing Setup of number of active cameras, display sequences, and camera numbers Initializing slope sensor Display cluster manual Back-up switch for failed cluster switch and accel dial To maximize engine cooling performance

(2) Monitoring

① Active fault - Machine

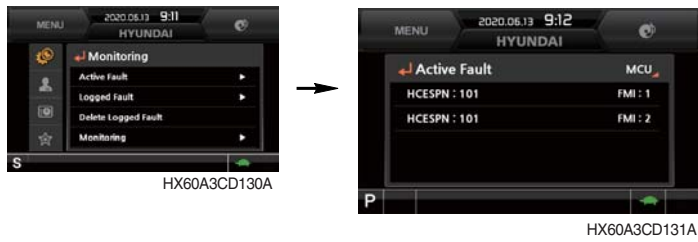

- The active faults of the machine MCU can be checked by this menu.

② Active fault - Engine

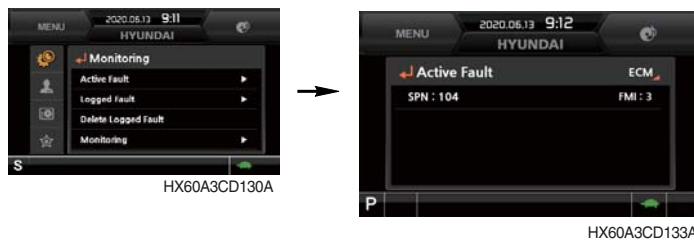

- The active faults of the engine ECU can be checked by this menu.

③ Logged fault - Machine/ Engine



- The logged faults of the machine MCU or engine ECU can be checked by this menu.
- This menu can be used only HCE service man.

④ Delete logged fault

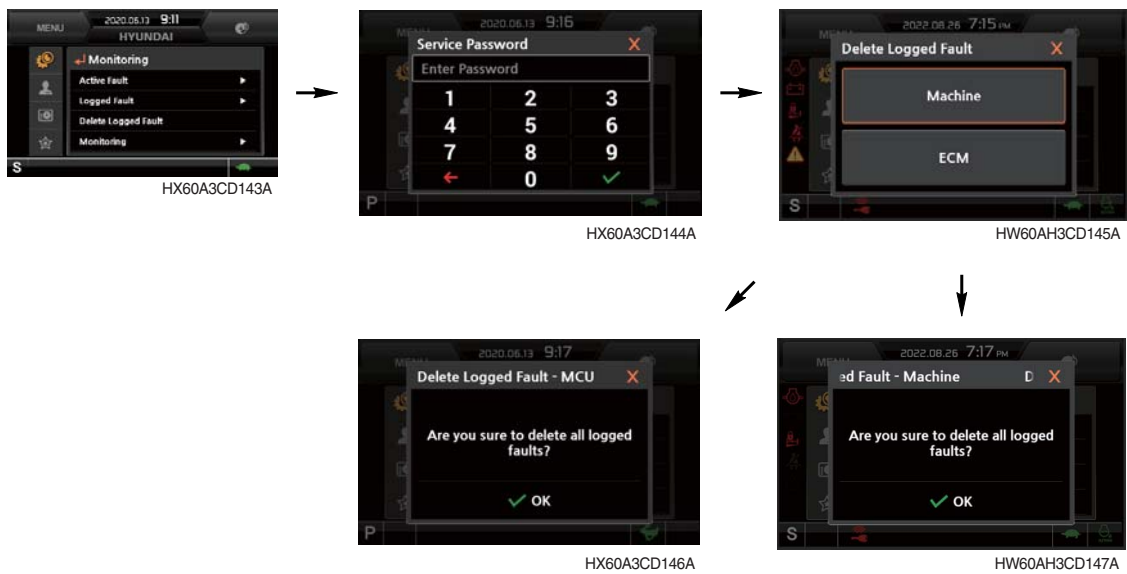

- The logged faults of the MCU, engine ECU can be deleted by this menu. (It is possible under the engine stop conditions)

⑤ Monitoring (machine status)

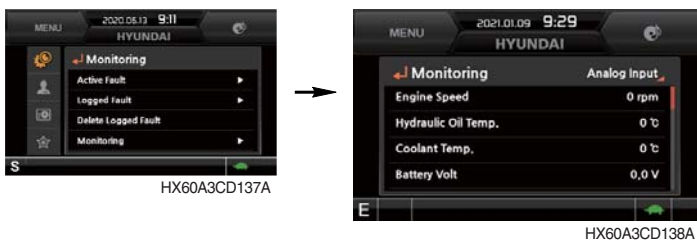

- The machine status such as the engine rpm, oil temperature, voltage and pressure etc. can be checked by this menu.

⑥ Monitoring (switch status)

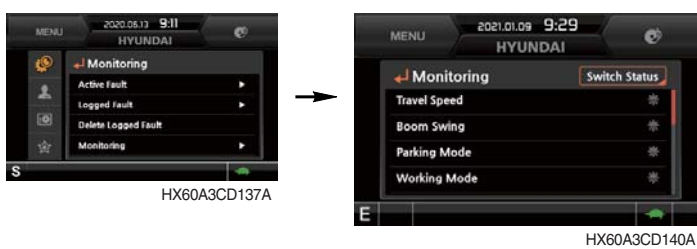

- The digital switch status of the machine can be checked by this menu.
- The activated switch will display in blue color.

⑦ Monitoring (output status)

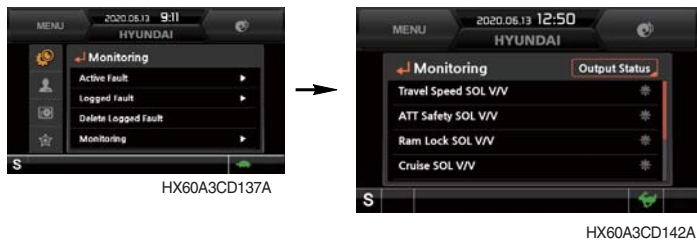

- The digital output status of the machine can be checked by this menu.
- The digital output status will display in blue color.

(3) Management

① Maintenance information

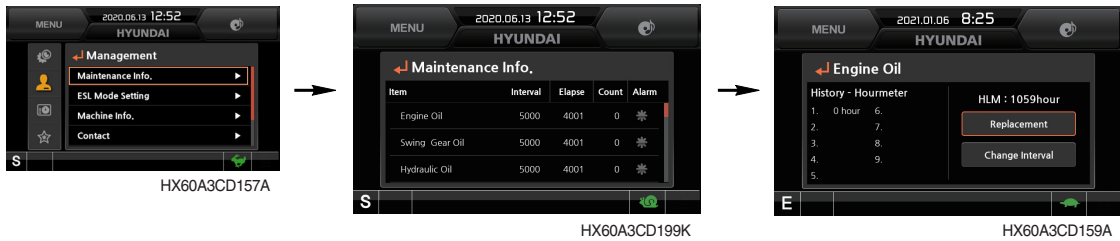

- Elapsed time : Display the elapsed time after the maintenance.
- Change interval : The change intervals can be changed in hour increments of 50.
- Change history : Display the change history for the maintenance.
- Replacement : The elapsed time will be reset to zero (0).
- Change or replace interval

※ Refer to the operator's manual page 6-16.

② Option flow control

a. Option attach selection



- Three kinds of option attachment can be selected by this menu.

- Rotary grapple (4-way)
- Grapple (2-way)
- Auger (2-way)

※ There are two user modes (type A or B) in each option attachment.

b. Proportional flow control setting

The preferable value of each option attachment can be set by this menu.

a) Rotary setting

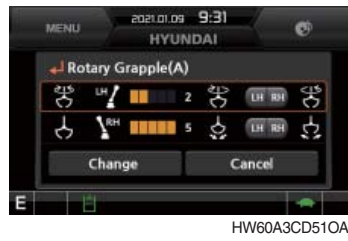

- Select rotary RCV, button and flow can be set by this menu

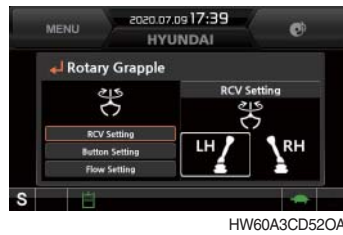

- RCV setting
 - Enable set LH or RH RCV for rotary operation.
 - Select LH for rotary → RH set for grapple automatically



- Button setting (CW rotation)
 - Select LH for CW rotation → RH set for CCW rotation automatically



- Flux setting
 - Enable set from level 1 to level 5.

b) Grapple setting



- Select grapple
RCV, button and flow can be set by this menu



- RCV setting
 - Enable set LH or RH RCV for grapple operation.
 - Select LH for grapple → RH set for rotary automatically



- Button setting (Close)
 - Select RH for Close → LH set for open automatically

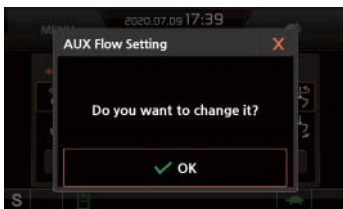

- Flow setting
 - Enable set from level 1 to level 5.



- Flow setting value can be saved by pressing change button.

- ※ Setting value saved once, it memorized in each icon and the last setting value is activated.
- ※ Saved setting can be used by pressing Icon button only.
- ※ There are two kinds (A and B) in each option attach setting and six kinds of option attach setting can be saved totally (2 of 4-way, 4 of 2-way).

c) Confirmation

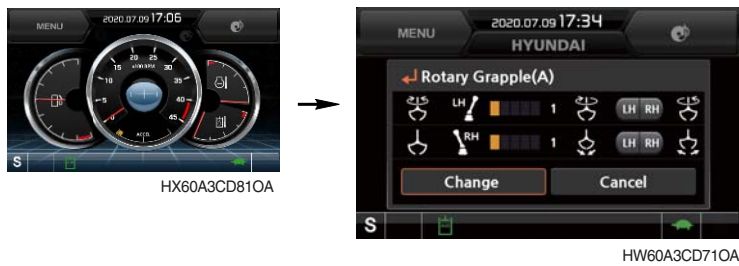

※ Symbol () is activated on the low side of main screen when option attach function is used.

※ Previous setting value can be checked by following procedure.

– Menu > Management > option attach

a) Rotary setting

- Rotary RCV : LH
- Rotary flow level : 3
- CW rotation : LH
- CCW rotation : RH

b) Grapple setting

- Grapple RCV : RH
- Grapple flow level : 3
- Open : LH
- Close : RH

③ ESL mode setting



– ESL : Engine Starting Limit

– ESL mode is designed to be a theft deterrent or will prevent the unauthorized operation of the machine.

– When you Enable the ESL mode, the password will be required when the starting switch is turned to the on position.

– Disable : ESL function is disabled and password is not required to start engine.

Enable (always) : The password is required whenever the operator starts engine.

Interval : The password is required when the operator starts engine first. But the operator can restart the engine within the interval time without inputting the password.

※ The interval time can be set to a maximum 4 hours.

※ Default password : 00000

Password length : 5~10 digits

Start Limit - Smart Key Setting (When smart key is installed)

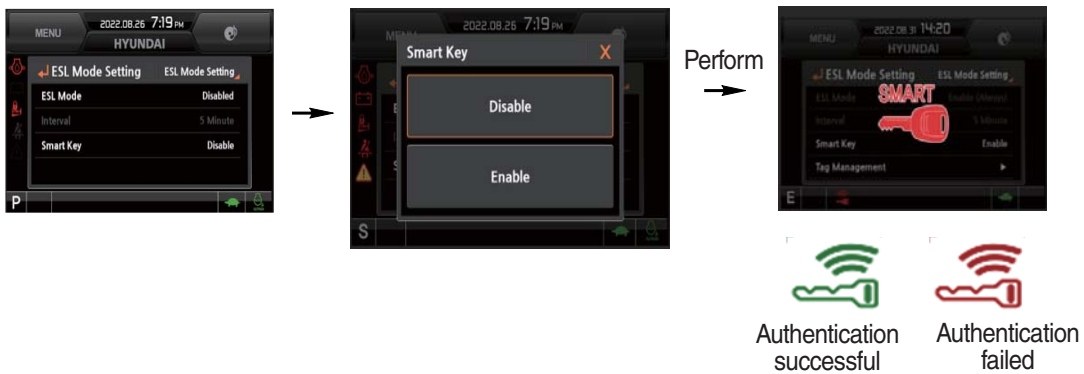

- Smart Key Exclusive

When the Smart key option (optional) is installed, Smart key menu is shown, and performance or non-performance of Smart key authentication can be set through the Smart key menu.

When the Smart key is not in the cabin, the approval procedure is rejected, and password must be entered.

Start Limit - Tag Management



- The tag management menu is activated only when the Smart key menu is set through performance. Tag can be registered or deleted.
 - When registering the tag : Locate only the tag preferred for registration inside the cabin.
 - When deleting the tag : All registered tags are deleted.

④ Password change

– The password is 5~10 digits.



Enter the current password



Select the password change

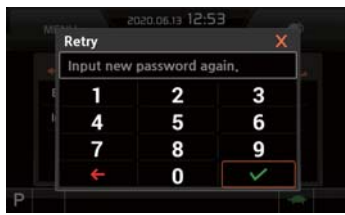

Saved the new password in the MCU



Enter the new password again



Enter the new password

⑤ Machine information



· The information of the cluster, machine MCU and engine and machine checked by this menu.

⑥ A/S phone number

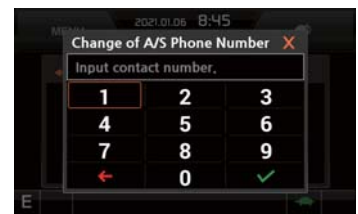

· The A/S phone number can be checked and changed.

⑦ Cluster update



HX60A3CD169A



HX60A3CD149A

Enter the user password



HX60A3CD170A

Select the cluster update

· The cluster and CAN device can be updated by this menu.

※ Do not turn power off while updating.

a. Application update



HX60A3CD172A

Select application item



HX60A3CD173A

Select file to update



HX60A3CD174A

Select OK



HX60A3CD176

Completed



HX60A3CD175A

In process

b. System update



HX60A3CD177A

Select system item



HX60A3CD173A

Select file to update



HX60A3CD174A

Select OK



HX60A3CD176

Completed



HX60A3CD175A

In process

⑧ CAN update

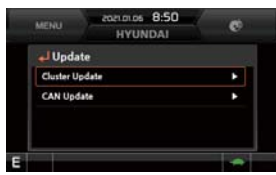

HX60A3CD169A

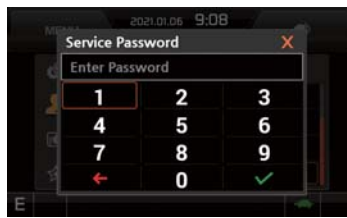

HX60A3CD149A

Enter the user password



HX60A3CD179A

Select the CAN update

· The application program can be downloaded and updated by this menu.

※ Do not turn power off while updating.

a. Download



HX60A3CD180A

Select update device



HX60A3CD181A

Select download



HX60A3CD182A

Select download after choose update file



HX60A3CD185A

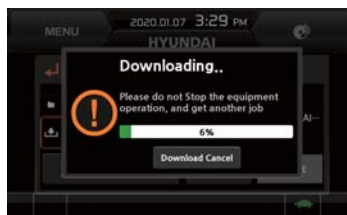

HX60A3CD184A

Stop download when select the cancel

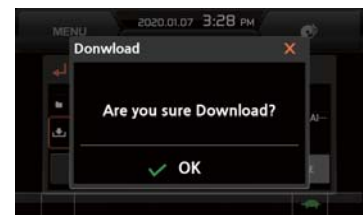

HX60A3CD183A

Confirm download

b. Update



HX60A3CD186A

Select update after the download.

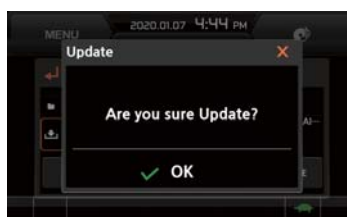

HX60A3CD187A

Confirm the update

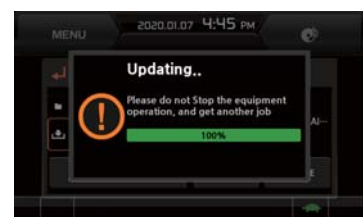

HX60A3CD188A

In process update

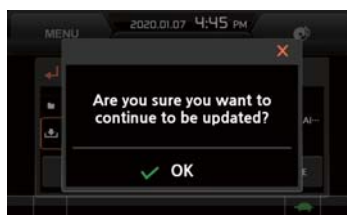

HX60A3CD190A

Select the OK to update another application program



HX60A3CD175A

Completed update

⑨ Service menu



Enter the manager password

- Power shift : Power shift mode (default/option can be set by this menu.
- Operating hours : Operating hours in individual modes since the machine line out can be checked by this menu.
- Main gauge type : The engine rpm or fuel level gauge can be display on the main gauge of the main screen by this menu.
- Display RPM : Display the numeric value of engine rpm on the main gauge of the main screen can be set by this menu.
- AVCU setting : Standard, 2-Way or 4-Way dependent upon the machine options can be selected by this menu.
- Adding language : The language displayed on the cluster can be update by this menu when it is required to correct language.

※ This menu can be used only HCE service man. Do not attempt unauthorized adjustment.

(4) Display

① Clock adjust



HX60A3CD191A



HX60A3CD192A

- The first row of boxes indicate Year/Month/Day.
- The second row shows the current time. (AM, PM/0:00~12:59)

② Brightness



HX60A3CD193A



HX60A3CD194A

Manual (1st~10th step)



HX60A3CD195A

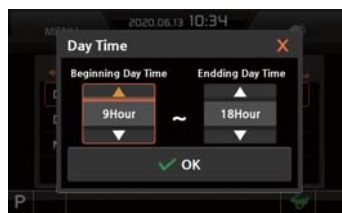

Auto (day/night)

HX60A3CD197A



Auto (day time)

HX60A3CD196A

- If "Auto" is chosen, brightness for day and night can be set accordingly. Also, users can define which day time interval. (Set day starting time and ending time)

③ Unit set

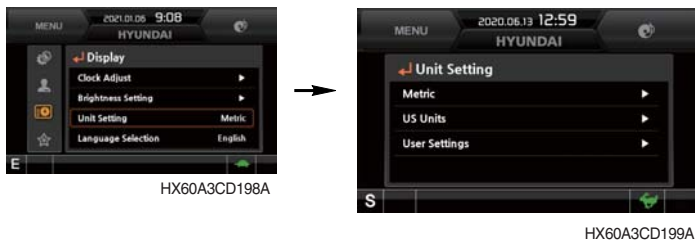

- Metric units : Units change to metric units.
- US units : Units change to U.S. units
- User setting : Units change to user setting units

Item	Metric units	U.S. units	User setting
Temperature	°C	°F	°C, °F
Distance	km	mile	km, mile
Pressure	bar	Mpa	bar, Mpa, kgf/cm ² , psi
Flow	lpm	gpm	lpm, gpm
Volume	l	gal	l, gal

④ Language selection



- User can select preferable language (22 languages) and all displays are changed the selected language.

(5) Utilities

① Entertainment

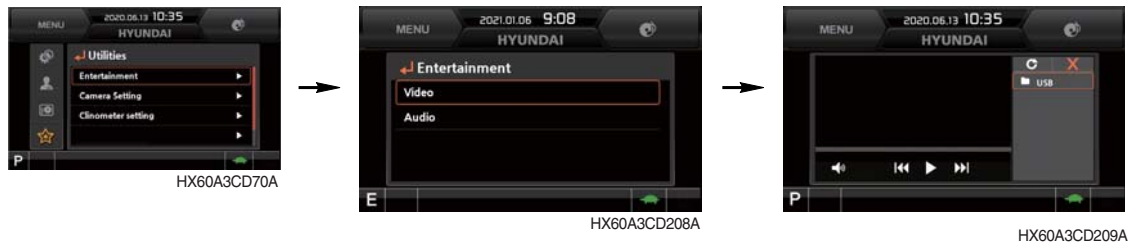

- Play MP4 or codec file of external hard disk through USB port.
- The USB port is located left side of the cluster.
- Over 1100 engine rpm, the screen turns into the operation screen with MP4 or codec file playing for the safety. The video is played again when the engine revolution is 1100 rpm or less.

▲ The video play is prohibited for the safety reason when the machine is operated.

② Camera setting



- Three cameras can be installed on the machine and display order can be set by this menu.
- If the camera is not equipped, this menu is not useful.
- Turning the select switch in clockwise direction, the next ordered will be shown and in counter-clockwise direction, the previously ordered will be shown. Also, the camera channel can be changed by touching the screen.
- Display change to reduction size or display is not visible by pushing the select switch or touch the screen.

(display reduction size → hiding → display)

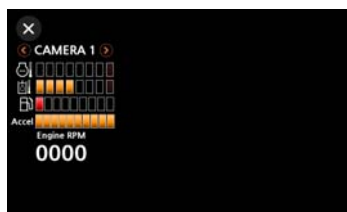

HX60A3CD204

- The camera display is terminated by pressing the ESC switch or touch the X icon on the screen.

■ Rear / RH view camera UI setting (Option)

1) Camera control switch

- Select the CAM switch to activate Rear / RH view camera from the beginning screen.
- While in that mode, select the ESC switch to return to the home screen.



2) Cam image control (CIC) mode

- Touch ① (Rear), ② (RH) button on screen to set single-view camera mode.
- Touch ③ (2CH-split-view) button to set split-view camera mode.

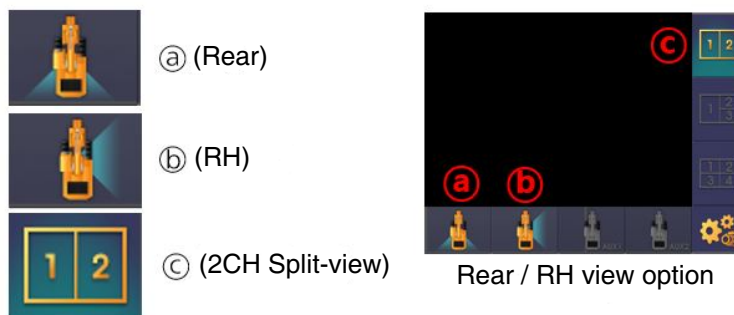

3) Split-view Camera order setting

- Touch ④ (camera setting) button to set split-view camera order.

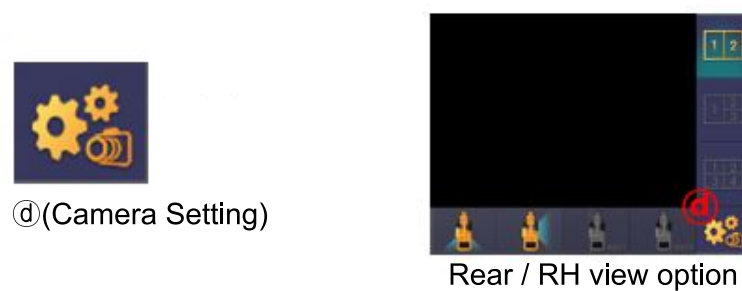

- You can change split-view camera order on display order menu.



③ Clinometer setting

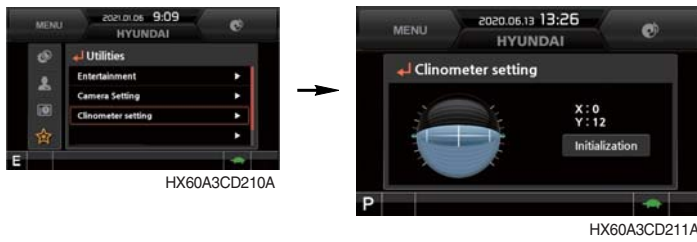

- When the machine is on the flatland, if you touch "initialization" on cluster, the values of X, Y will reset to "0".
- You can confirm tilt of machine in cluster's operating screen.

④ Manual



- Manual of the cluster can be read on the monitor.

⑤ Emergency mode

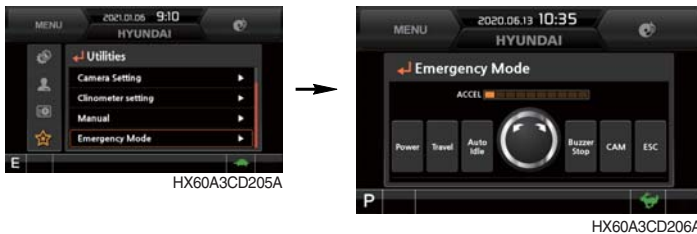

- When switches of the monitor and the accel dial fails, switches are displayed on LCD, and you are allowed to perform operation by touching the screen.
- Such operation is allowed only on this mode screen.

⑥ Quick Cooling Mode



- While the machine is stopped and discontinued with operation, engine can be operated in maximum RPM for maximum rotation of the radiator fan. (Max. for 5 minutes)
 - Setting : When the machine is stopped, the safety lever is lowered to set the quick cooling mode in the locked state
 - Release : Released when the operating time exceeds 5 minutes, when the safety lever is cleared, and when the quick cooling mode release button is pressed

GROUP 3 ELECTRICAL CIRCUIT

ELECTRICAL CIRCUIT (1/2)

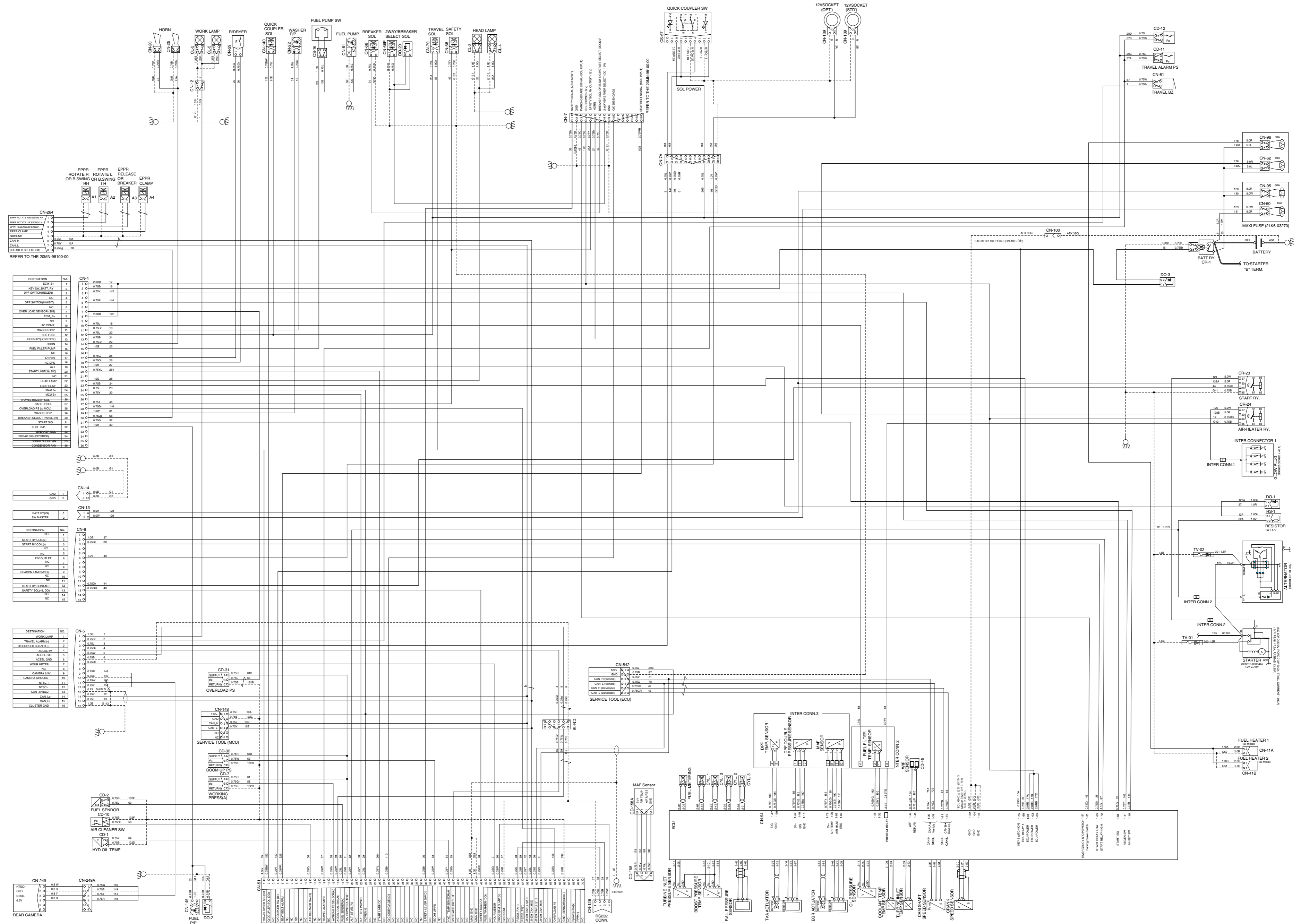

ELECTRICAL CIRCUIT (2/2)

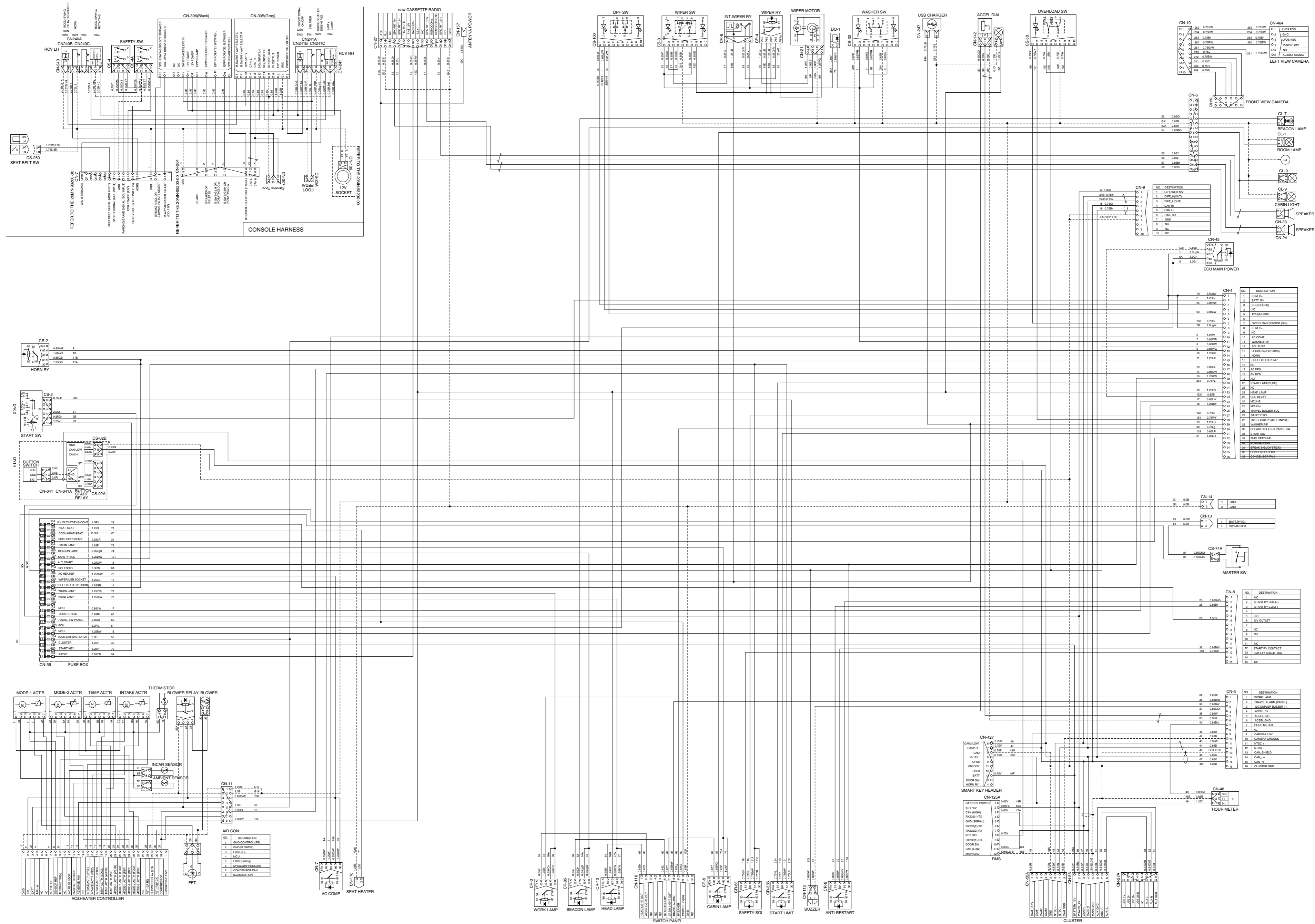

MEMORANDUM

1. POWER CIRCUIT

The negative terminal of battery is grounded to the machine chassis.

When the start switch is in the OFF position, the current flows from the positive battery terminal as shown below.

1) OPERATING FLOW

Battery (B⁺) → Battery relay (CR-1) → Maxi fuse (CN-60) → I/conn [CN-13 (2)] → Master switch [CS-74A]

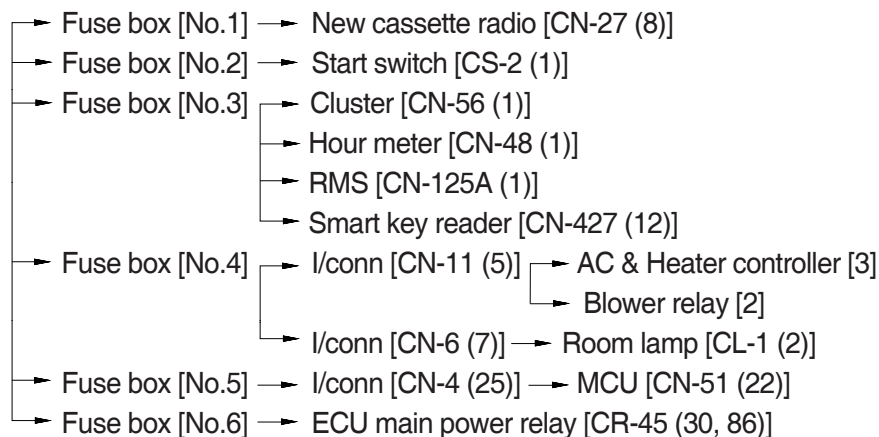

※ I/conn : Intermediate connector

2) CHECK POINT

Engine	Start switch	Check point	Voltage
STOP	OFF	① - GND (battery B ⁺) ② - GND (battery relay) ③ - GND (fusible link)	10~12.5V

※ GND : Ground

POWER CIRCUIT

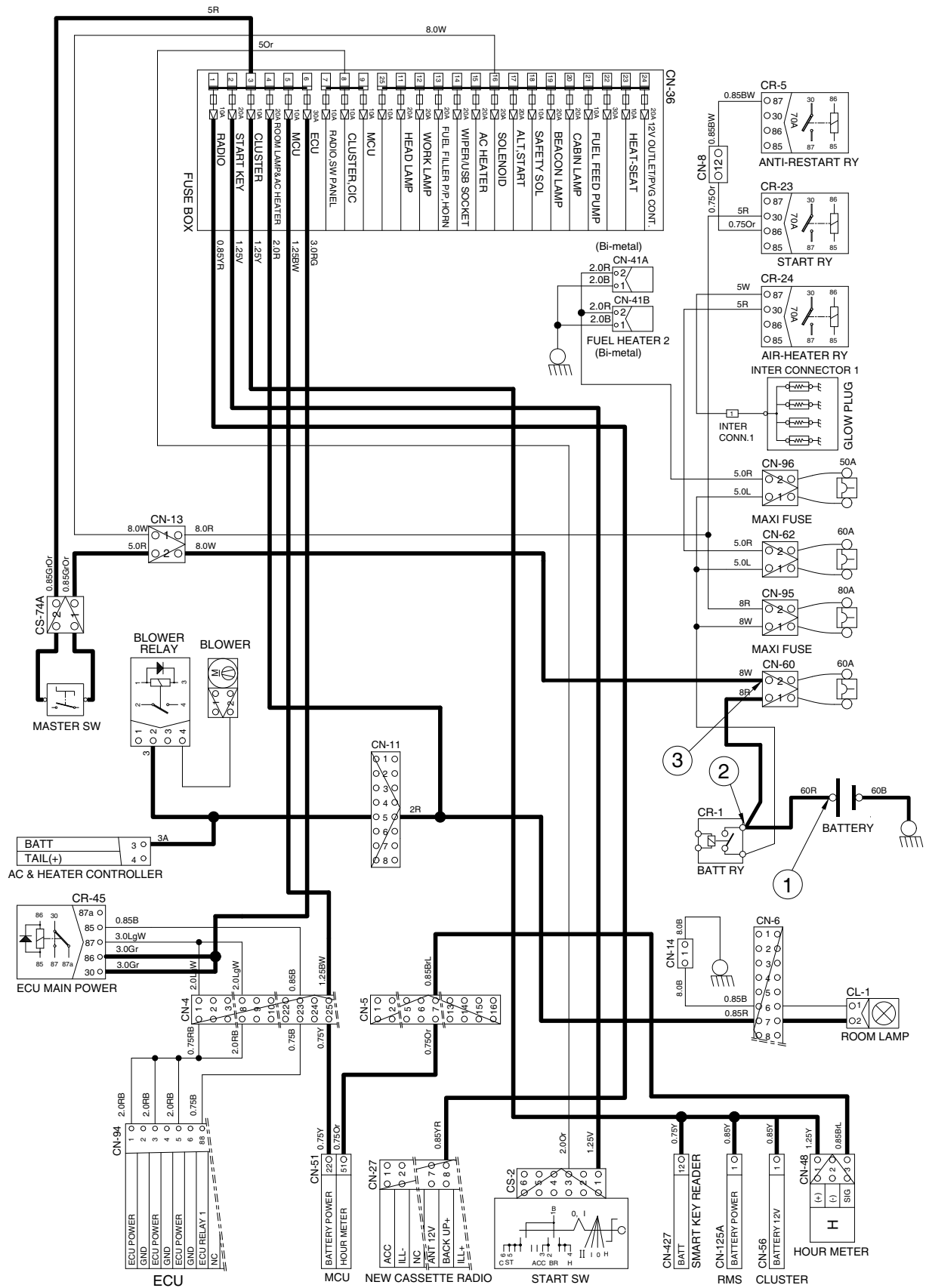

HX65A4EL05

2. STARTING CIRCUIT

1) OPERATING FLOW

Battery (+) terminal → Battery relay [CR-1] → Maxi fuse [CN-60]
 → I/conn [CN-13 (2)] → Master switch [CS-74A] → Fuse box No.2 → Start key [CS-2 (1)]

※ Start switch : ON

→ Start switch ON [CS-2 (2)] → I/conn [CN-4 (2)] → ECU [CN-94 (1-75)]
 → Battery relay [CR-1]
 Battery relay [CR-1] : Battery relay operating (all power is supplied with the electric component)
 → Start switch ON [CS-2 (3)] → Fuse box (No. 7, 8, 9)] → I/conn [CN-4 (24)] →
 MCU [CN-51 (23)]

※ Start switch : START

Start switch START [CS-2 (6)] → Start limit relay [CR-385 (30) → (87)] → I/conn [CN-4 (31)]
 → ECU [CN-94A (1-84) → (1-72)]
 → I/conn [CN-8 (3) → Anti-restart relay [CR-5 (85) → (87)] → I/conn [CN-8 (12)]
 → Start relay [CR-23 (86) → (87)] → Starter operating

2) CHECK POINT

Engine	Start switch	Check point	Voltage
Operating	START	① - GND (battery B ⁺) ② - GND (start key) ③ - GND (battery relay M4) ④ - GND (starter B) ⑤ - GND (starter S) ⑥ - GND (start relay) ⑦ - GND (battery relay M8)	10~12.5V

※ GND : Ground

STARTING CIRCUIT

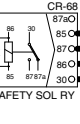
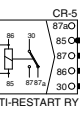
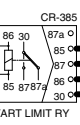
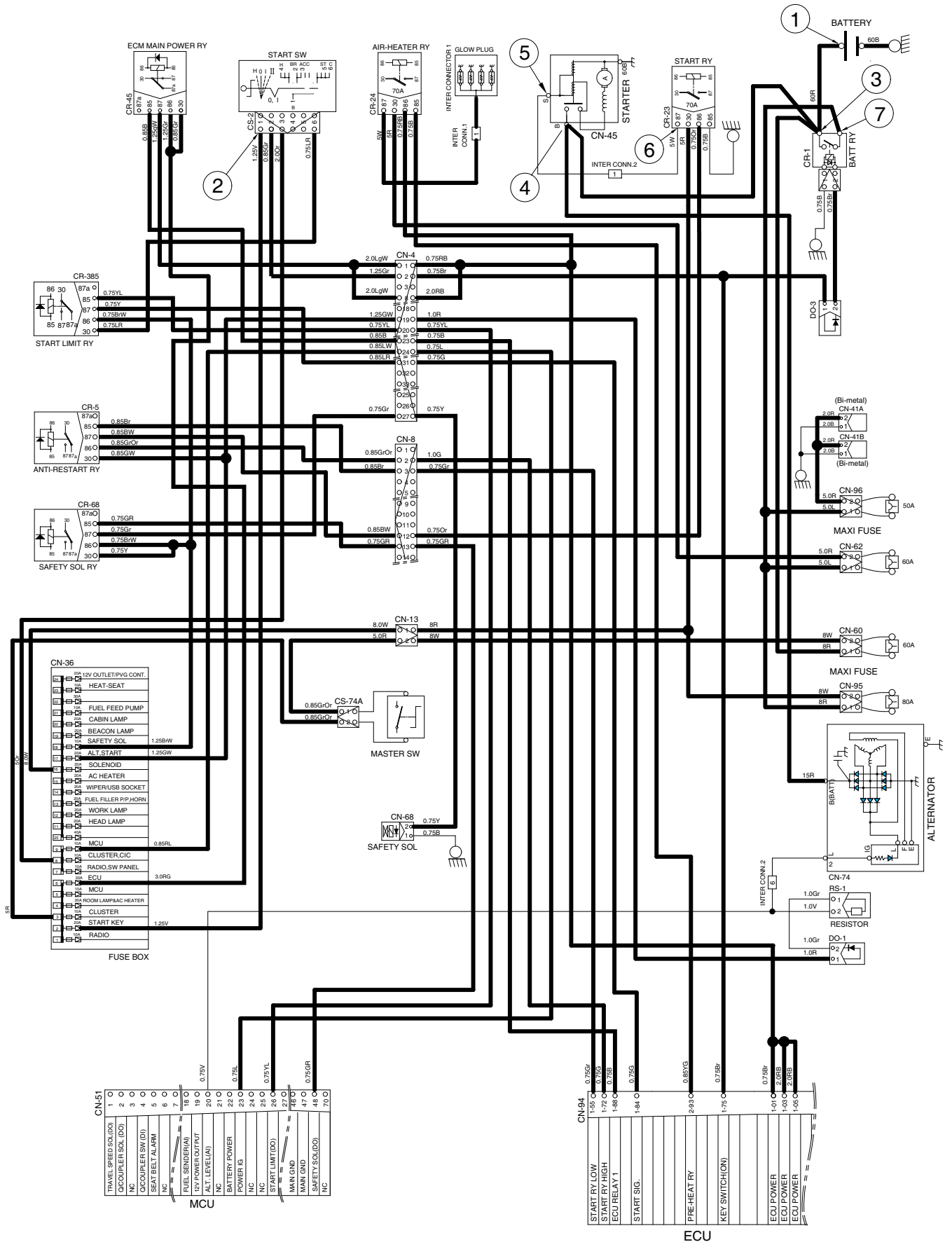

CN-36

12V OUTLET/PIV G. CONT.
HEAT-SEAT
FUEL FEED PUMP
CABIN LAMP
BEACON LAMP
SAFETY SOL 1.25BW
ALT.START 1.25GW
SOLENOID
AC HEATER
WIPER/USB SOCKET
FUEL FILLER PIP/HORN
WORK LAMP
HEAD LAMP
MCU 0.85RL
CLUSTER/CIC
RADIO/SW PANEL
ECU 3.0RG
MCU
ROOM LAMP/AC HEATER
CLUSTER
START KEY 1.25V
RADIO

CN-51

1	TRAVEL SPEED SOL(DO)
2	COUPLER SOL (DO)
3	NC
4	COUPLER SW (DI)
5	SEAT BELT ALARM
6	NC
7	NC
18	FUEL SENDER(N)
19	12V POWER OUT/PT
20	ACT.LEVEL(L)
21	NC
22	BATTERY POWER
23	BATTERY G
24	NC
25	NC
26	START LIMIT(DO)
27	NC
28	NC
29	NC
30	MAN GND
47	MAN GND
48	SAFETY SOL(DO)
70	NC

CN-94

1.35	START RY LOW
1.72	START RY HIGH
1.88	ECU RELAY 1
1.84	START SIG.
2.83	PRE-HEAT RY
1.75	KEY SWITCH(ON)
0.75R	ECU POWER
2.0RB	ECU POWER
1.55C	ECU POWER

HX65A4EL06

3. CHARGING CIRCUIT

When the starter is activated and the engine is started, the operator releases the start switch to the ON position.

Charging current generated by operating the alternator flows into the battery through the battery relay (CR-1).

The current also flows from the alternator to each electrical component and controller through the fuse box.

1) OPERATING FLOW

(1) Warning flow

Alternator [CN-74 (L)] → I/conn 2 [6] → MCU [CN-51 (20)] → Cluster warning lamp

(2) Charging flow

Alternator [CN-74 (B)] → Starter [CN-45 (B)] → Battery relay [CR-1]

→ Battery (+) terminal

→ Maxi fuse [CN-60] → I/conn [CN-13 (2)] → Master switch [CN-74A]

→ Fuse box [CN-36 No.1~6]

→ Maxi fuse [CN-95] → I/conn [CN-13 (1)] → Fuse box [CN-36 No.11~25]

2) CHECK POINT

Engine	Start switch	Check point	Voltage
Operating	ON	① - GND (battery B ⁺) ② - GND (battery relay) ③ - GND (alternator B terminal) ④ - GND (alternator L terminal) ⑤ - GND (MCU)	10~12.5V

※ GND : Ground

CHARGING CIRCUIT

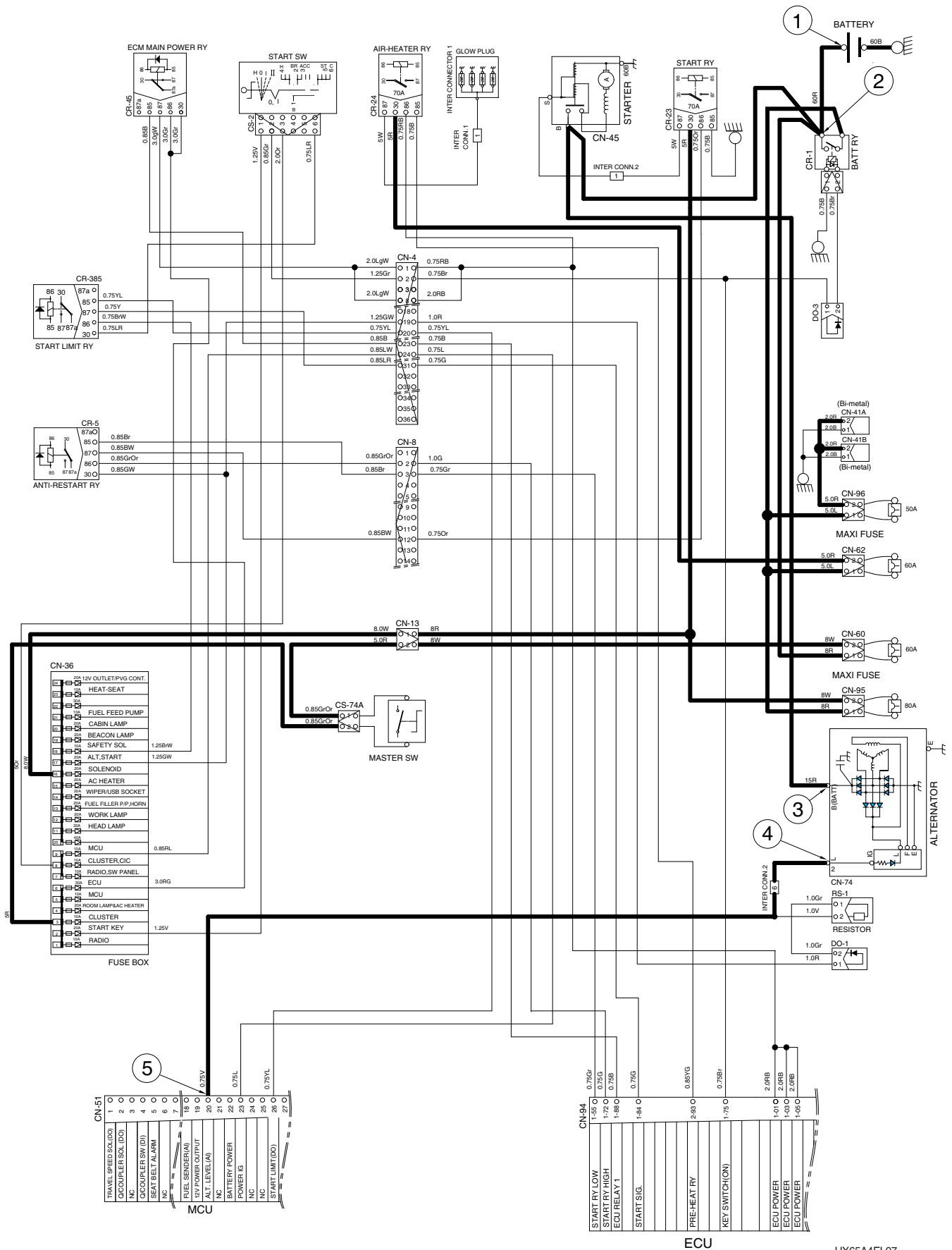

HX65A4EL07

4. HEAD AND WORK LAMP CIRCUIT

1) OPERATING FLOW

Fuse box (No.11) → Head lamp relay [CR-13 (30, 86)]

Fuse box (No.12) → Work lamp relay [CR-3 (30, 86)]

Fuse box (No.7) → Switch panel [CR-116 (10)]

(1) Head lamp switch ON

Head lamp switch ON [CN-116 (1)] → Head lamp relay [CR-13 (85) → (87)]

→ I/conn [CN-4 (22)] → Head lamp ON [CL-3, 4 (2)]

→ New cassette radio illumination ON [CN-27 (9)]

→ Accel dial illumination ON [CN-142 (2)]

→ I/conn [CN-11 (8)] → AC/Heater controller illumination ON

(2) Work lamp switch ON

Work light switch ON [CN-116 (2)] → Work lamp [CR-3 (85) → (87)] → I/conn [CN-5 (1)]

I/conn [CN-12 (2)] → Work lamp ON [CL-5 (2)]

2) CHECK POINT

Engine	Start switch	Check point	Voltage
STOP	ON	① - GND (fuse box) ② - GND (switch power output) ③ - GND (switch relay input) ④ - GND (head light) ⑤ - GND (fuse box) ⑥ - GND (switch power output) ⑦ - GND (switch relay input) ⑧ - GND (work light)	10~12.5V

※ GND : Ground

HEAD AND WORK LAMP CIRCUIT

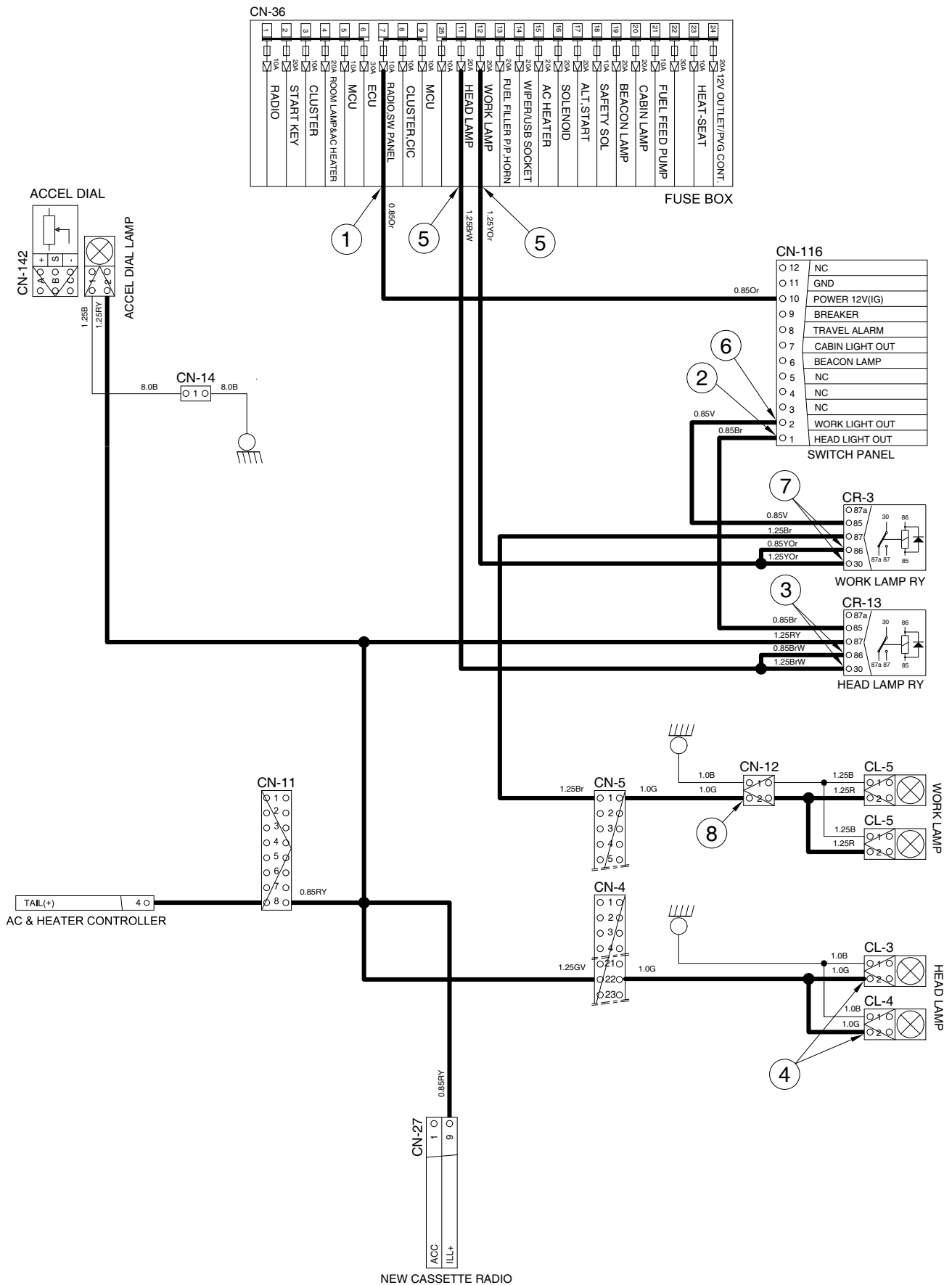

HX65A4EL08

5. BEACON LAMP AND CAB LAMP CIRCUIT

1) OPERATING FLOW

Fuse box (No.18) → Beacon lamp relay [CR-85 (30, 86)]

Fuse box (No.20) → Cab lamp relay [CR-9 (30, 86)]

Fuse box (No.7) → Switch panel [CN-116 (10)]

(1) Beacon lamp switch ON

Beacon lamp switch ON [CN-116 (6)] → Beacon lamp relay [CR-85 (85) → (87)]

→ I/conn [CN-6 (5)] → Beacon lamp ON [CL-7 (2)]

(2) Cab lamp switch ON

Cab lamp switch ON [CN-116 (7)] → Cab lamp relay [CR-9 (85) → (87)] → I/conn [CN-6 (8)]

→ Cab lamp ON [CL-9 (2)]

2) CHECK POINT

Engine	Start switch	Check point	Voltage
STOP	ON	① - GND (fuse box) ② - GND (switch power output) ③ - GND (relay power input) ④ - GND (beacon lamp) ⑤ - GND (cab lamp)	10~12.5V

※ GND : Ground

BEACON AND CAB LAMP CIRCUIT

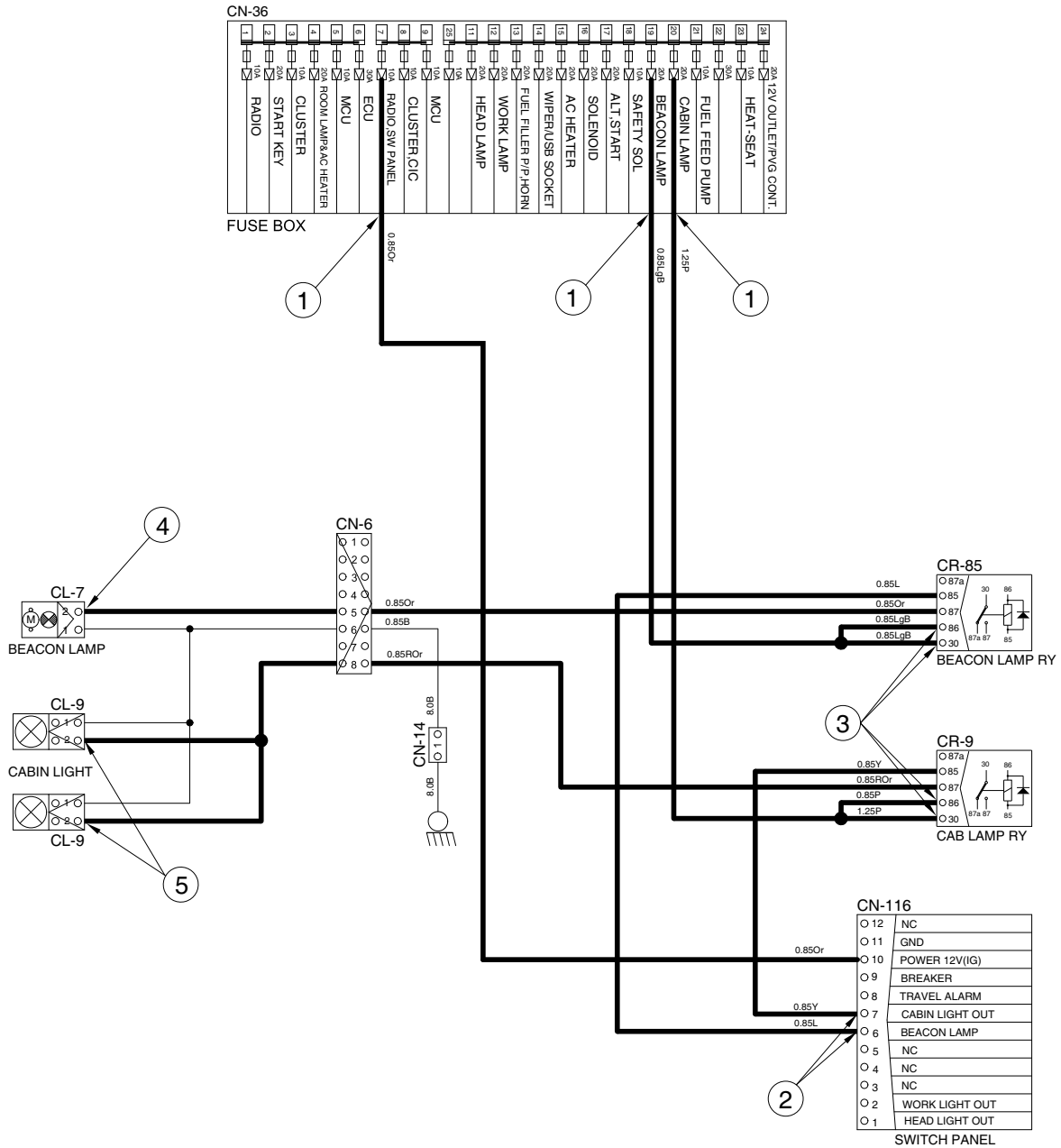

HX65A4EL09

6. WIPER AND WASHER CIRCUIT

1) OPERATING FLOW

(1) Key switch ON

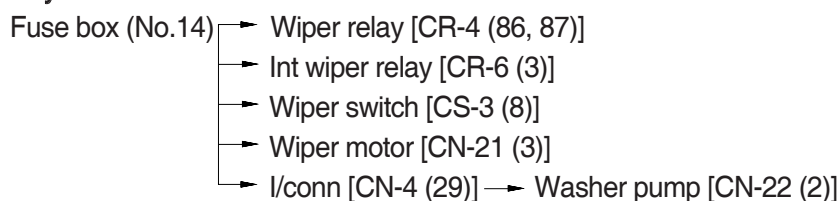

(2) Wipe switch ON : 1st step (intermittent speed)



(3) Wiper switch ON : 2nd step (continual)



(4) Washer switch ON

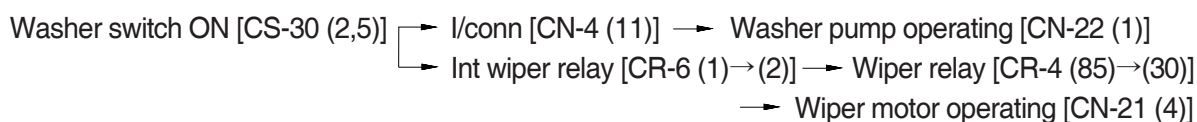

(5) Auto parking (when switch OFF)

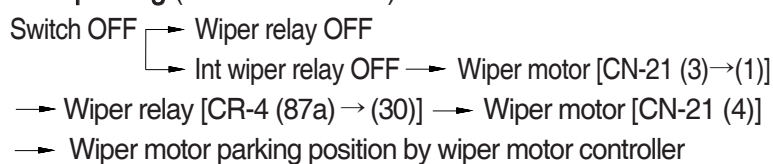

2) CHECK POINT

Engine	Start switch	Check point	Voltage
STOP	ON	① - GND (fuse box) ② - GND (switch power input) ③ - GND (switch power output) ④ - GND (wiper motor)	10~12.5V

※ GND : Ground

WIPER AND WASHER CIRCUIT

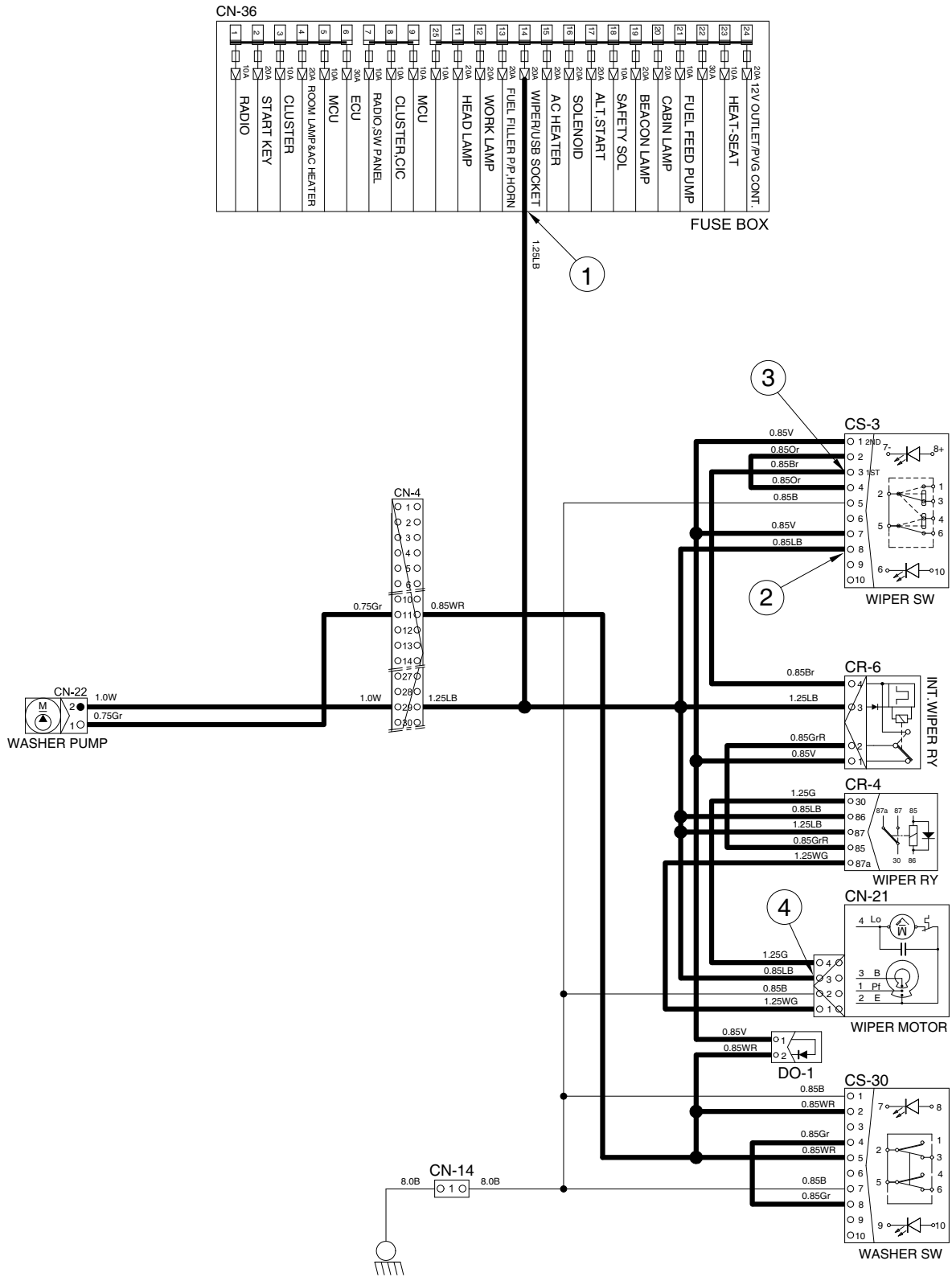

HX65A4EL10

MONITORING CIRCUIT

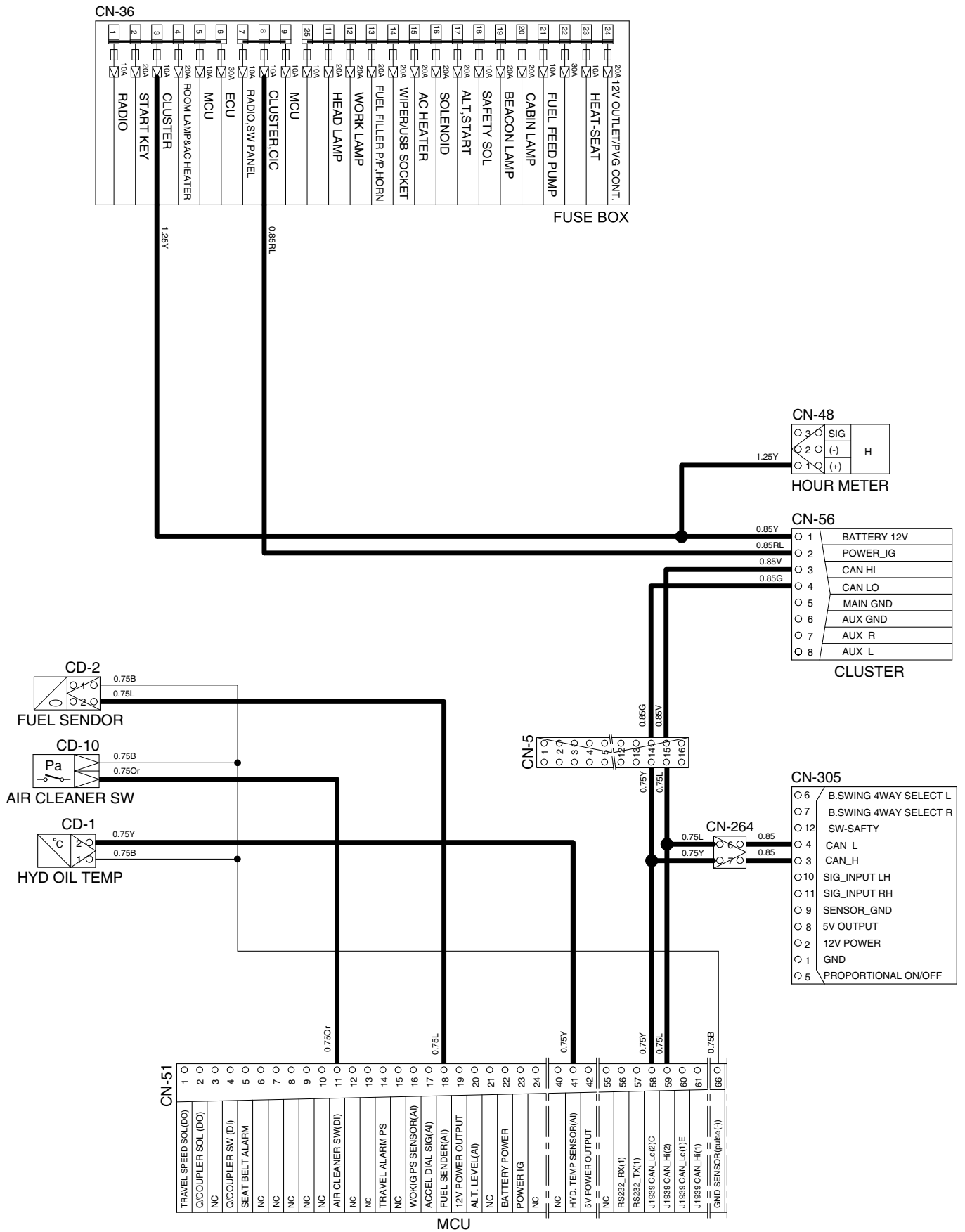

HX65A4EL11

ELECTRIC CIRCUIT FOR HYDRAULIC (1/2)

See electric circuit for hydraulic (2/2)

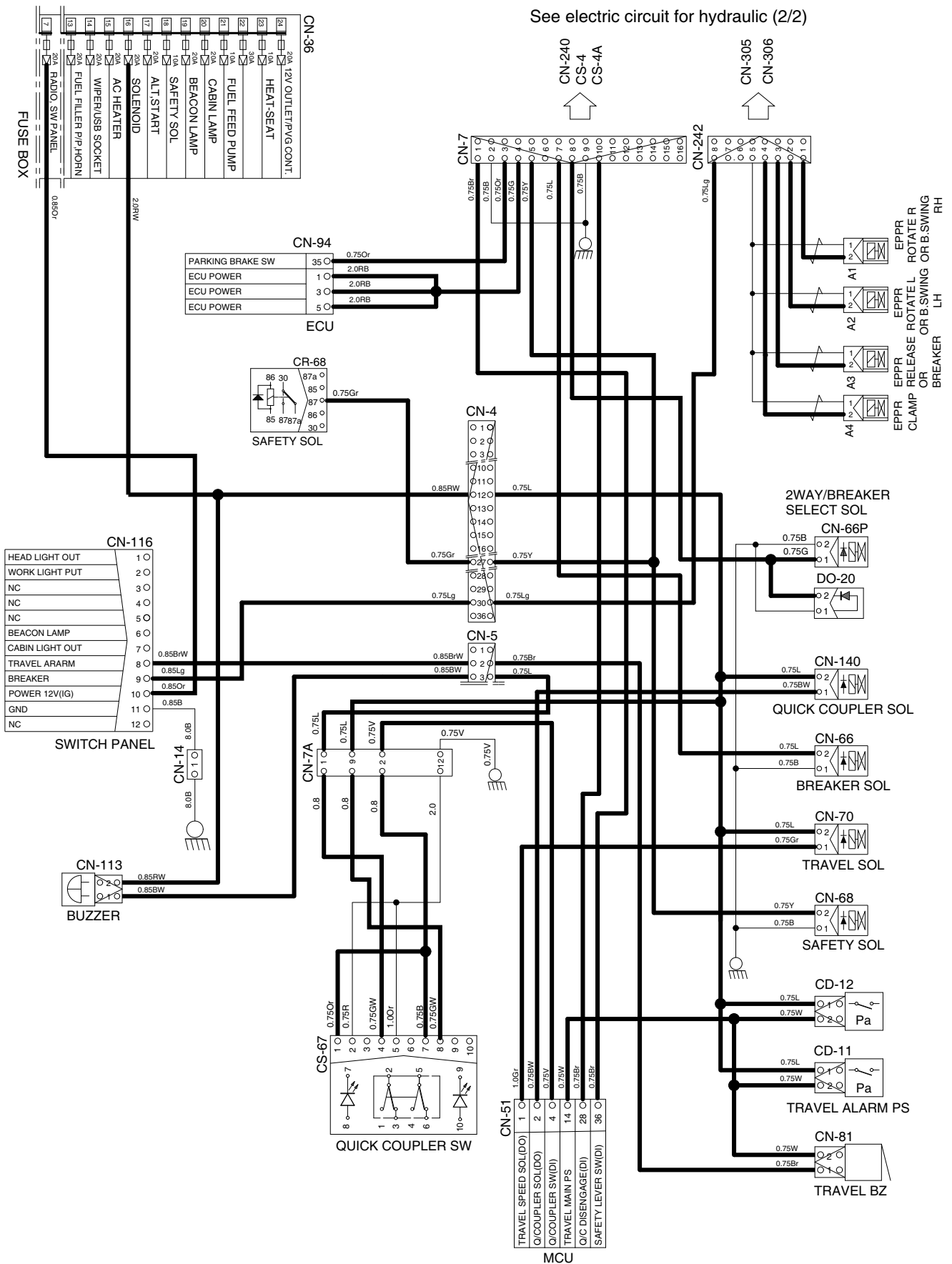

HX65A4EL12

ELECTRIC CIRCUIT FOR HYDRAULIC (2/2)

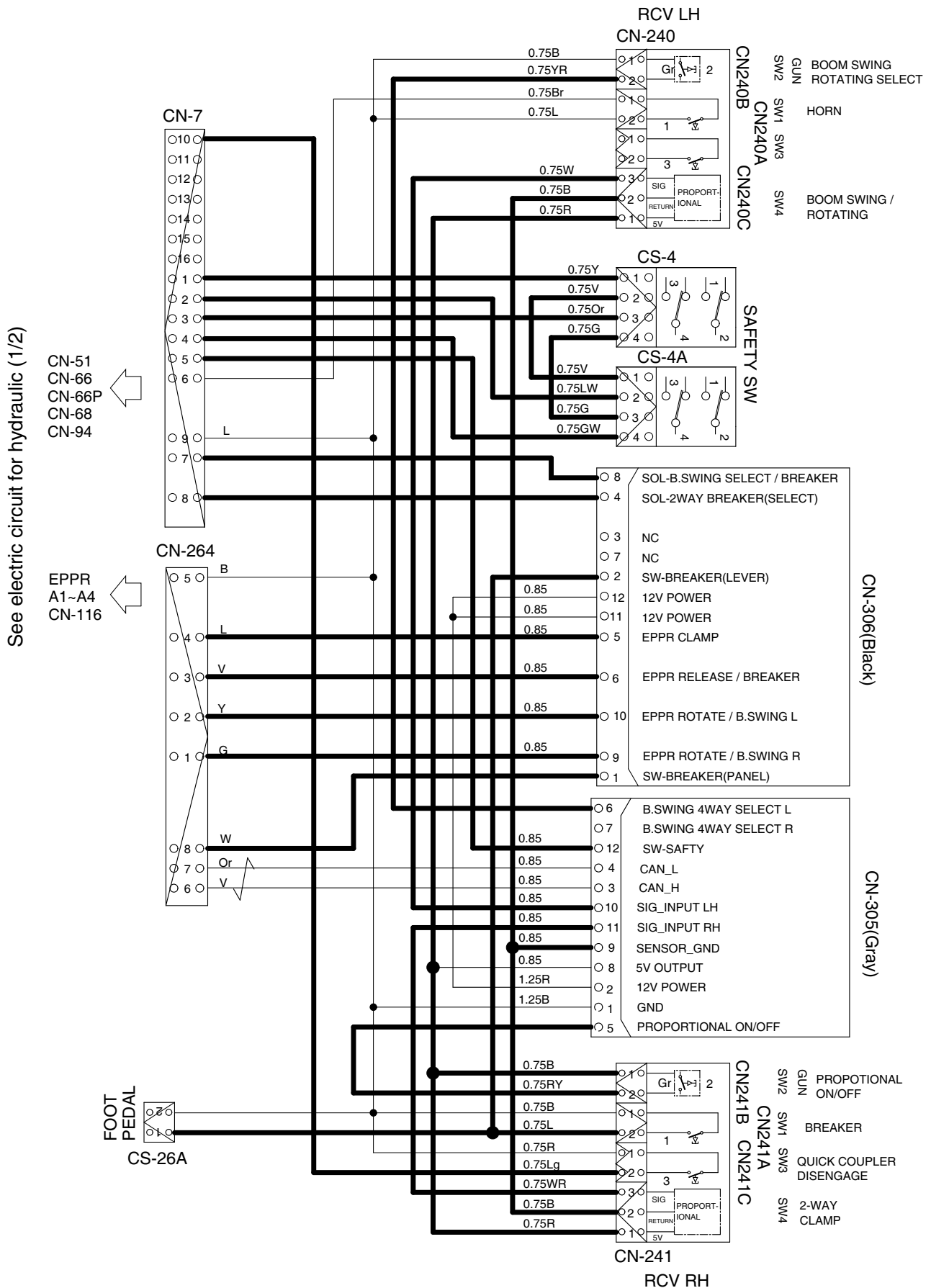

See electric circuit for hydraulic (1/2)

CN-51
CN-66
CN-66P
CN-68
CN-94

EPPR
A1~A4
CN-116

FOOT
PEDAL

CS-26A

GROUP 4 ELECTRICAL COMPONENT SPECIFICATION

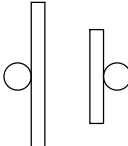
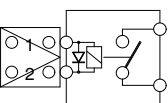
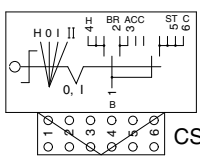
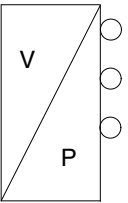
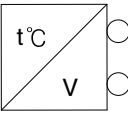
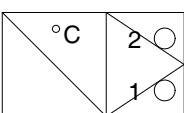
Part name	Symbol	Specification	Check
Battery		12V × 100Ah	※ Check specific gravity 1.280 over : over charged 1.280 ~ 1.250 : normal 1.250 below : recharging
Battery relay	 CR-1	Rated load : 12V 100A (continuity) 1000A (30 second)	※ Check coil resistance Normal : about 12Ω ※ Check contact Normal : ∞Ω
Start switch	 CS-2	12V	※ Check contact OFF : ∞Ω (for each terminal) ON : 0Ω (for terminal 1-3 and 1-2) START : 0Ω (for terminal 1-6)
Pressure switch (for engine oil)		-	※ Check resistance Normal : 0Ω (CLOSE)
Coolant temperature sensor		-	※ Check resistance 50°C : 804Ω 80°C : 310Ω 100°C : 180Ω
Hydraulic temperature sensor		-	※ Check resistance 50°C : 804Ω 80°C : 310Ω 100°C : 180Ω

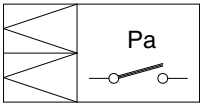
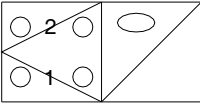
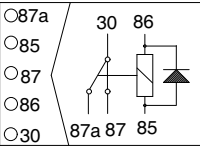
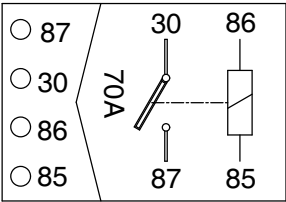
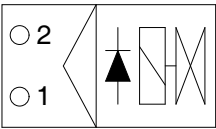
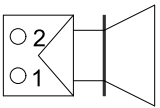
Part name	Symbol	Specification	Check
Air cleaner pressure switch	 <p>CD-10</p>	Pressure: 635mmH ₂ O (N.O TYPE)	※ Check contact Normal : ∞ Ω
Fuel sender	 <p>CD-2</p>	-	※ Check resistance Full : 100 Ω Low : 500 Ω Empty warning : 700 Ω
Relay	 <p>CR-2 CR-3 CR-4 CR-5 CR-7 CR-9 CR-13 CR-45 CR-68 CR-85 CR-385</p>	12V 20A	※ Check resistance Normal : about 200 Ω (for terminal 85-86) : 0 Ω (for terminal 30-87a) : ∞ Ω (for terminal 30-87)
Relay (Start, Air heater)	 <p>70A</p>	12V 70A	※ Rated coil current 1.2 ± 0.3A
Solenoid valve	 <p>CN-66 CN-66P CN-68 CN-70 CN-140</p>	12V 1A	※ Check resistance Normal : 15~25 Ω (for terminal 1-2)
Speaker	 <p>CN-23(LH) CN-24(RH)</p>	4 Ω 20W	※ Check resistance Normal : 4 Ω

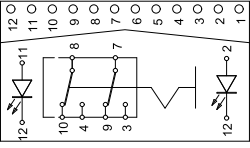
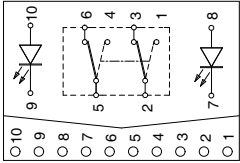
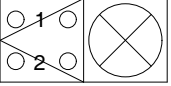
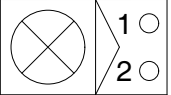
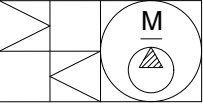
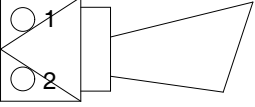
Part name	Symbol	Specification	Check
Overload switch	 <p>CS-50</p>	12V 16A	※ Check contact Normal OFF - $\infty \Omega$ (for terminal 1-5,2-6) - 0Ω (for terminal 5-7,6-8)
Quick clamp switch	 <p>CS-67</p>	12V 16A	※ Check contact Normal OFF - $\infty \Omega$ (for terminal 1-5,2-6) - 0Ω (for terminal 5-7,6-8)
Lamp	 <p>CL-3 CL-4 CL-5 CL-9</p>	12V 55W (H3 TYPE)	※ Check disconnection Normal : 1.2Ω
Room lamp	 <p>CL-1</p>	12V 10W	※ Check disconnection Normal : a few Ω
Fuel filler pump	 <p>CN-61</p>	12V 35 l / min	※ Check operation Supply power (for terminal 1) : 12V
Horn	 <p>CN-20 CN-25</p>	12V	100±5dB

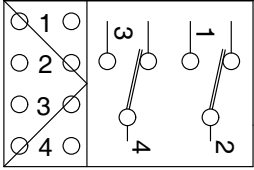
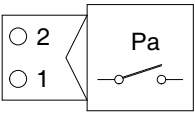
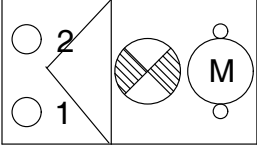
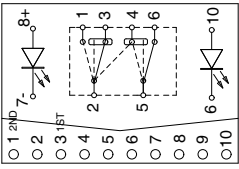
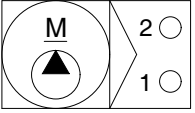
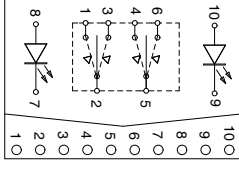
Part name	Symbol	Specification	Check
Safety switch	 <p>CS-4 CS-4A</p>	-	-
Pressure switch	 <p>CD-11 CD-12</p>	10bar (N.C type)	※ Check contact Normal : 0.1Ω
Beacon lamp	 <p>CL-7</p>	12V (Strobe type)	※ Check disconnection Normal : a fewΩ
Wiper switch		12V 16A	※ Check contact Normal : ∞Ω
Washer pump	 <p>CN-22</p>	12V 3.8A	※ Check contact Normal : 3Ω (for terminal 1-2)
DPF switch	 <p>CS-100</p>	12V 16A	※ Check contact Normal : ∞Ω (for terminal 1-2, 4-5)

Part name	Symbol	Specification	Check
Wiper motor	<p>CN-21</p>	12V 3A	-
New cassette radio	<p>CN-27</p>	24V 2A	※ Check voltage 20 ~ 25V (for terminal 1-3, 3-8)
Receiver dryer	<p>CN-29</p>	12V (N.O type)	※ Check contact Normal : $\infty \Omega$ (for terminal 1-2)
Starter	<p>CN-45</p>	12V 2.5kW	※ Check contact Normal : 0.1Ω
Alternator	<p>CN-74</p>	12V 90A	※ Check contact Normal : 0Ω (for terminal B-L)
Travel buzzer	<p>CN-81</p>	12V	-

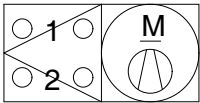
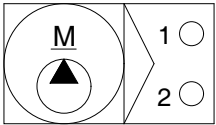
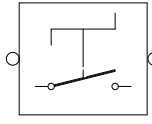
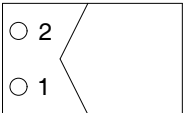
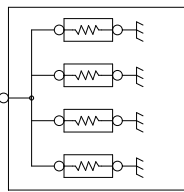
Part name	Symbol	Specification	Check
Hour meter	 <p>CN-48</p>	12V	-
Air con blower		12V 8.5A	-
Fuel feed pump	 <p>CN-145</p>	12V	-
Master switch	 <p>CS-74A</p>	12V 1000A	-
Fuel heater	 <p>CN-41A CN-41B</p>	12V 38W	-
Glow plug		-	-

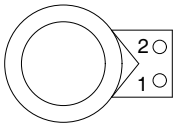
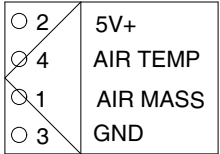
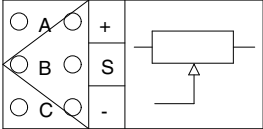
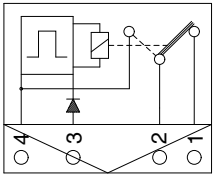
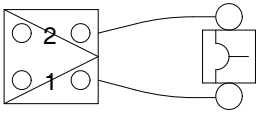
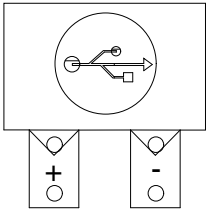
Part name	Symbol	Specification	Check
12V socket	 CN-139	12V 120W	-
MAF sensor	 CD-158A	5V	-
Accel dial	 CN-142	-	※ Check resistance Normal : about 5k Ω (for terminal A-C) ※ Check voltage Normal : about 5V (for terminal A-C) : 2~4.5V (for terminal C-B)
Int wiper relay	 CR-6	12V 12A	-
Maxi fuse	 CN-60 CN-62 CN-95 CN-96	12V, 50A (CN-96) 12V, 60A (CN-60, 62) 12V, 80A (CN-95)	-
USB charger	 CN-247	-	-

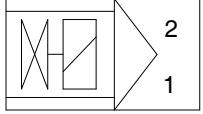
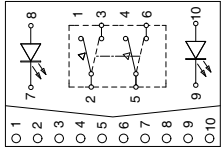
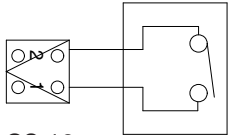
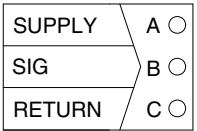
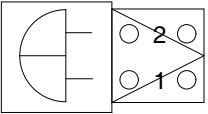
Part name	Symbol	Specification	Check
EPPR valve	 <p>A1, A2, A3, A4</p>	-	-
Washer switch	 <p>CS-30</p>	12V 16A	※ Check resistance Normal OFF $-\infty \Omega$ (for terminal 2-3, 5-6)
Fuel pump switch	 <p>CS-16</p>	-	-
Pressure sensor	 <p>CD-7 CD-31 CD-32</p>	8~30A	※ Check contact Normal -0.1Ω
Buzzer	 <p>CN-113</p>	12V	-

GROUP 5 CONNECTORS

1. CONNECTOR DESTINATION

Connector number	Type	No. of pin	Destination	Connector part No.	
				Female	Male
CN-4	AMP	36	Cabin room harness - Main harness	1743059-2	1743062-3
CN-5	AMP	16	Cabin room harness - Main harness	368047-1	368050-1
CN-6	AMP	16	Cabin harness - Cabin room lamp harness	368047-1	368050
CN-7	AMP	16	Main harness-console harness	368047-1	368050-1
CN-7A	AMP	12	Main harness-console harness	174661-2	368537-1
CN-8	-	15	Cabin room harness-Main harness	2-85262-1	368301-1
CN-9	AMP	10	AAVM harness	174655-2	174657-2
CN-11	DEUTSCH	8	Air-con harness	DT06-8S-EP06	-
CN-12	AMP	2	Main harness - Boom lamp harness	S816-002002	S816-102002
CN-13	KET	2	Earth	MG620557-5	MG620558-5
CN-14	-	2	Earth	S813-030201	-
CN-16	AMP	6	Power connector	174264-2	-
CN-16A	AMP	6	Power connector	-	174262-2
CN-19	AMP	10	AAVM-RH camera harness	174655-2	174657-2
CN-20	DEUTSCH	2	Horn	DT06-2S-EP06	-
CN-21	AMP	4	Wiper harness	180900-0	-
CN-22	KET	2	Washer tank	MG640605	-
CN-23	KET	2	Speaker LH	MG610070	-
CN-24	KET	2	Speaker RH	MG610070	-
CN-25	DEUTSCH	2	Horn	DT06-2S-EP06	-
CN-27	KUM	16	Cassette & radio	PK145-16017	-
CN-27A	-	8	Cassette & radio	-	S816-108002
CN-29	KET	2	Receiver dryer	MG640795	-
CN-36	-	-	Fuse box	21MN-55100	-
CN-41A	DELPHI	2	Fuel heater 1	15300027	-
CN-41B	DELPHI	2	Fuel heater 2	15300027	-
CN-45	TERM	-	Starter	-	-
CN-48	TERM	4	Hour meter	2-520193-2	-
CN-51	AMP	70	MCU	1-968879-1	-
CN-56	AMP	8	Cluster	-	S816-106002
CN-56A	AMP	8	Cluster	174982	-
CN-60	AMP	8	Maxi fuse	21K6-03270	03.01060
CN-61	DEUTSCH	2	Fuel filler pump	DT06-2S-EP06	DT04-2P-E005
CN-62	-	-	Maxi fuse	21K6-03270	03.01060

Connector number	Type	No. of pin	Destination	Connector part No.	
				Female	Male
CN-66	DEUTSCH	2	Breaker solenoid	DT06-2S-EP06	-
CN-66P	DEUTSCH	2	2way / breaker select sol	DT06-2S-EP06	DT04-2P-E005
CN-68	DEUTSCH	2	Safety solenoid	DT06-2S-EP06	-
CN-70	DEUTSCH	2	Travel HI-LO solenoid	DT06-2S-EP06	-
CN-74	DONGA	1	Alternator	S820-408000	-
CN-81	DEUTSCH	2	Travel buzzer	DT06-2S-EP06	DT04-2P-E005
CN-94	BOSCH	91	ECU	1 928 405 452	-
CN-95	-	-	Maxi fuse	21K6-03270	03.01080
CN-96	-	-	Maxi fuse	21K6-03270	03.01050
CN-100	KET	1	ECU ground	MG640944-5	-
CN-113	AMP	2	Buzzer	S810-002202	-
CN-116	AMP	12	Switch panel	368542-1	-
CN-125A	DEUTSCH	12	RMS	DT06-126-P021	DT04-12PA-P021
CN-126	DEUTSCH	4	RS232	DT06-4S-EP06	DT04-4P-E005
CN-139	AMP	2	12V socket (opt)	172434-2	-
CN-139	AMP	2	12V socket (std)	174198-1	-
CN-140	DEUTSCH	2	Quick coupler	DT06-2S-EP06	DT04-2P-E005
CN-142	DEUTSCH	3	Accel dial	DT06-3S-EP06	-
CN-142	AMP	2	Accel dial lamp	174352-2	-
CN-145	DEUTSCH	2	Fuel feed pump	DT06-2S-EP06	-
CN-148	DEUTSCH	6	Service tool	DT06-6S-EP06	DT04-6P-E005
CN-157	-	1	Antena power	S822-014000	-
CN-170	AMP	2	Seat heat switch	12162017	-
CN-170	-	2	Seat belt switch	12052641	-
CN-240	DEUTSCH	3	Boom swing/rotating	DT06-3S-EP06	-
CN-240A	DEUTSCH	2	Horn	-	DT04-2P-E005
CN-240B	DEUTSCH	3	Boom swing/rotating sel	DT06-2S-EP06	-
CN-240C	-	1	-	-	S822-114000
CN-241	DEUTSCH	3	2 way clamp	DT06-3S-EP06	-
CN-241A	DEUTSCH	2	Breaker	-	DT04-2P-E005
CN-241B	DEUTSCH	3	Proportional ON/OFF	DT06-2S-EP06	-
CN-241C	-	1	Q/C disengage	-	S822-114000
CN-247	AMP	1	USB socket	171809	-
CN-249A	DEUTSCH	6	Rear camera	DT06-6S-EP06	DT04-6P-E005
CN-264	DEUTSCH	8	PVG EPPR	DT06-8S	DT04-8P
CN-264	DEUTSCH	8	Console harness-Main harness	DT06-8S	-
CN-305	DEUTSCH	12	AVCU	DTM06-06-12SA	-
CN-306	DEUTSCH	12	AVCU	DTM06-06-12SB	-

Connector number	Type	No. of pin	Destination	Connector part No.	
				Female	Male
CN-307	DEUTSCH	3	Service tool	DT06-3S-EP06	DT04-3P-E005
CN-402	DEUTSCH	6	Front view camera	DT06-6S-EP06	DT04-6P-E005
CN-404	DEUTSCH	6	LH view camera	DT06-6S-EP06	DT04-6P-E005
CN-427	-	12	Smart key reader	5557-12R	5559-12P
CN-542	DEUTSCH	6	Service tool (ECU)	DT06-6S-EP06	DT04-6P-E005
CN-641	KET	3	Button key (opt)	MG641035	-
CN-641A	KET	3	BKCU	MG651032	-
CN-A1	DEUTSCH	2	EPPR- Rotate or boom swing RH	DT06-2S-EP06	-
CN-A2	DEUTSCH	2	EPPR- Rotate or boom swing LH	DT06-2S-EP06	-
CN-A3	DEUTSCH	2	EPPR- Release or breaker	DT06-2S-EP06	-
CN-A4	DEUTSCH	2	EPPR- Clamp	DT06-2S-EP06	-
CN-INTER 1	KET	1	Inter connection 1	-	MG643800
CN-INTER 2	KET	6	Inter connection 2	-	MG610513
CN-INTER 3	DEUTSCH	12	Inter connection 3	-	DT04-12P-E005
· LAMP					
CL-1	KET	2	Room lamp	MG610392	-
CL-3	DEUTSCH	2	Head lamp	DT06-2S-EP06	DT04-2P-E005
CL-4	DEUTSCH	2	Head lamp	DT06-2S-EP06	DT04-2P-E005
CL-5	DEUTSCH	2	Work lamp	DT06-2S-EP06	DT04-2P-E005
CL-7	DEUTSCH	2	Beacon lamp	DT06-2S-EP06	DT04-2P-E005
CL-9	DEUTSCH	2	Cabin lamp	DT06-2S-EP06	DT04-2P-E005
CL-10	DEUTSCH	2	Cabin lamp	DT06-2S-EP06	DT04-2P-E005
· RELAY					
CR-1	AMP	2/-	Battery relay	S816-002002	S816-100002
CR-1	DONGA	-	Battery relay contact (IG)	S820-408000	-
CR-1	DONGA	-	Battery relay contact (B ⁺)	S820-408000	-
CR-2	-	5	Horn relay	SJA003526-001	-
CR-3	-	5	Work lamp relay	SJA003526-001	-
CR-4	-	5	Wiper relay	SJA003526-001	-
CR-5	-	5	Anti-restart relay	SJA003526-001	-
CR-6	KET	4	Int wiper relay	MG652999	-
CR-7	-	5	AC comp relay	SJA003526-001	-
CR-9	-	5	Cabin lamp relay	SJA003526-001	-
CR-13	-	5	Head lamp relay	SJA003526-001	-
CR-23	KET	4	Start relay	MG612017-5	-
CR-24	KET	4	Air heater relay	MG612017-5	-
CR-45	-	5	ECU power relay	SJA003526-001	-
CR-68	-	5	Safety solenoid relay	SJA003526-001	-

Connector number	Type	No. of pin	Destination	Connector part No.	
				Female	Male
CR-85	-	5	Beacon lamp relay	SJA003526-001	-
CR-385	-	5	Start limit relay	SJA003526-001	-
· SENDER					
CD-1	AMP	2	Hydraulic temp sender	85202-1	-
CD-2	AMP	2	Fuel sender	-	S816-102002
CD-7	DEUTSCH	3	Auto idle pressure switch	DT06-3S-EP06	-
CD-10	AMP	2	Air cleaner switch	85202-1	-
CD-11	KET	2	Travel pressure switch	MG640795	-
CD-12	KET	2	Travel pressure switch	MG640795	-
CD-31	DEUTSCH	3	Overload pressure	DT06-3S-EP06	DT04-3P-E005
CD-32	DEUTSCH	3	Boom up pressure	DT06-3S-EP06	-
CD-45	DEUTSCH	2	WIF sensor	DT06-2S-EP06	-
CD-158	AMP	4	MAF connector	-	1-1564559-1
CD-158A	AMP	4	MAF sensor	1-178645-1	-
DO-1	AMP	2	Diode	174352-2	21EA-50570
DO-2	AMP	2	Diode	174352-2	21EA-50550
DO-3	-	2	Diode	S816-002002	21EA-50550
DO-20	AMP	2	Diode	S816-002002	21EA-50550
· SWITCH					
CS-2	KET	6	Start key switch	S814-006000	-
CS-2A	-	6	Start key	S814-006000	-
CS-2B	DEUTSCH	3	BKCU	DT06-3S-EP06	DT04-3P-E005
CS-3	CARLING	10	Wiper switch	VC2-01	-
CS-4	AMP	3	Safety switch	174257-2	-
CS-4A	AMP	4	Safety switch	-	174259-2
CS-16	AMP	2	Fuel filler pump switch	174352-2	174354-2
CS-26	DEUTSCH	2	Fool pedal	DT06-2S-EP06	-
CS-26A	AMP	2	Foot pedal	174352-2	174359-2
CS-30	CARLING	10	Wiper/washer switch	VC2-01	-
CS-50	CARLING	10	Overload switch	VC2-01	-
CS-67	CARLING	10	Quick coupler switch	VC2-01	-
CS-74A	YAZAKI	2	Master switch	S813-030201	S813-130201
CS-100	CARLING	10	DPF switch	VC2-01	-
CS-250	DEUTSCH	2	Seat belt alarm	DT06-2S-EP06	DT04-2P-E005

2. CONNECTION TABLE FOR CONNECTORS

1) PA TYPE CONNECTOR

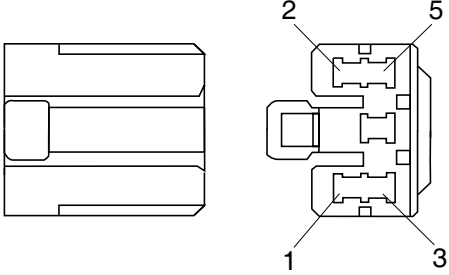
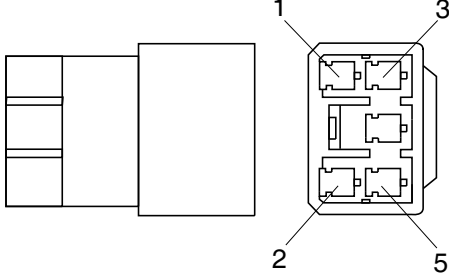
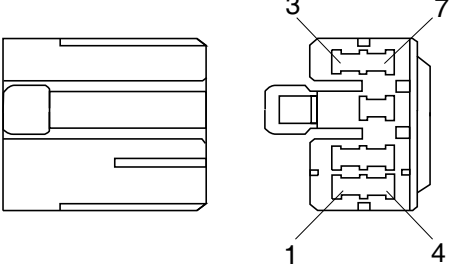
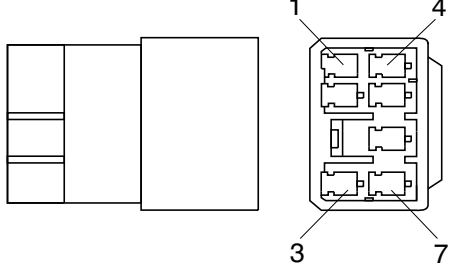
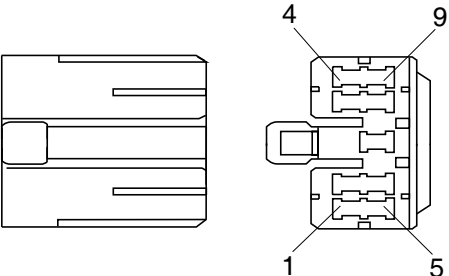
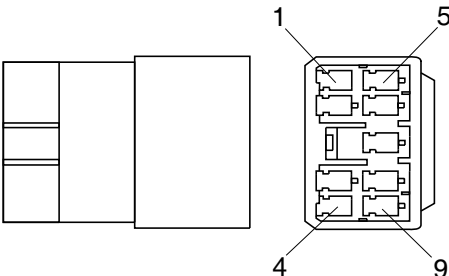
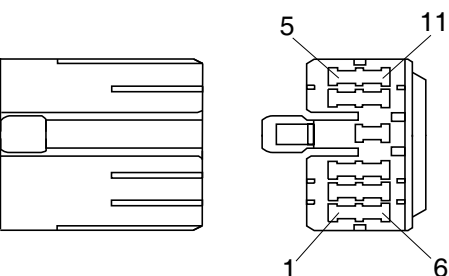
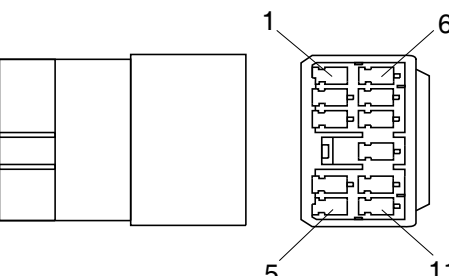
No. of pin	Receptacle connector (female)	Plug connector (male)
5	 <p data-bbox="687 741 836 770">S811-005002</p>	 <p data-bbox="1240 741 1388 770">S811-105002</p>
7	 <p data-bbox="687 1144 836 1173">S811-007002</p>	 <p data-bbox="1240 1144 1388 1173">S811-107002</p>
9	 <p data-bbox="687 1552 836 1581">S811-009002</p>	 <p data-bbox="1240 1552 1388 1581">S811-109002</p>
11	 <p data-bbox="687 1955 836 1984">S811-011002</p>	 <p data-bbox="1240 1955 1388 1984">S811-111002</p>

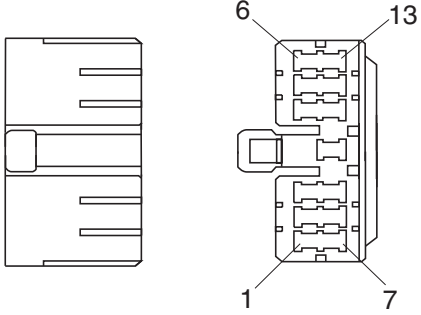
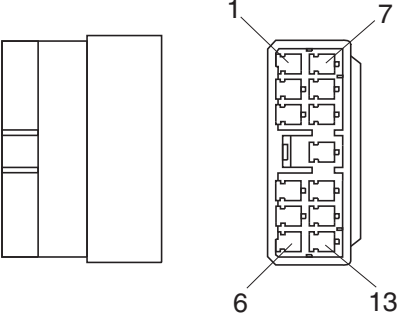
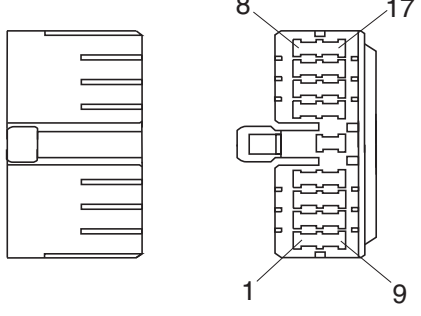
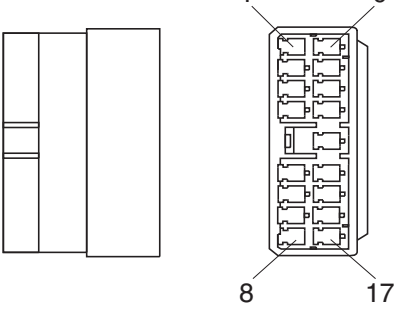
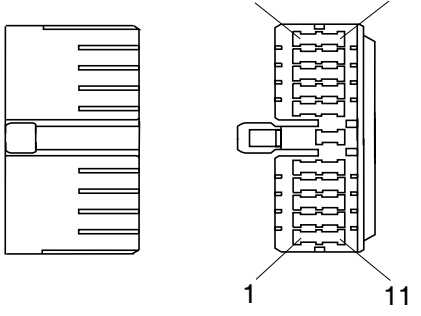
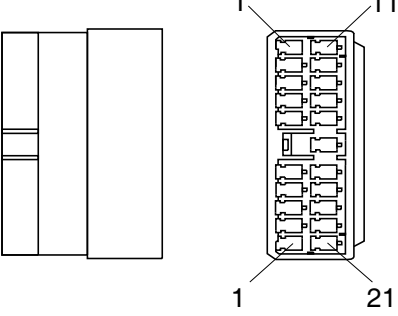
No. of pin	Receptacle connector (female)	Plug connector (male)
13	 <p data-bbox="689 638 837 672">S811-013002</p>	 <p data-bbox="1241 638 1390 672">S811-113002</p>
17	 <p data-bbox="689 1048 837 1081">S811-017002</p>	 <p data-bbox="1241 1048 1390 1081">S811-117002</p>
21	 <p data-bbox="689 1451 837 1485">S811-021002</p>	 <p data-bbox="1241 1451 1390 1485">S811-121002</p>

2) J TYPE CONNECTOR

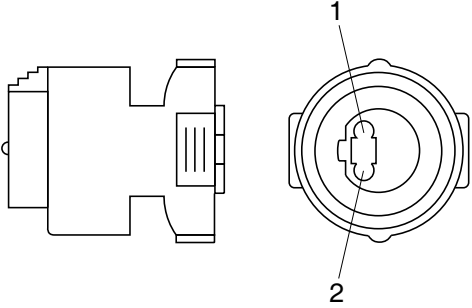
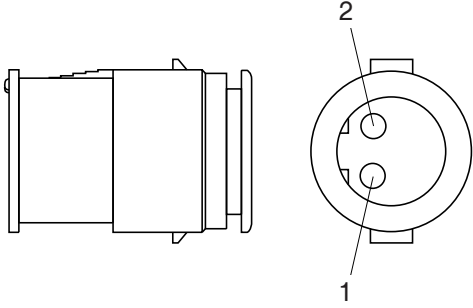
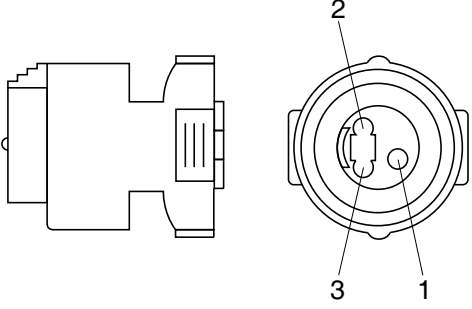
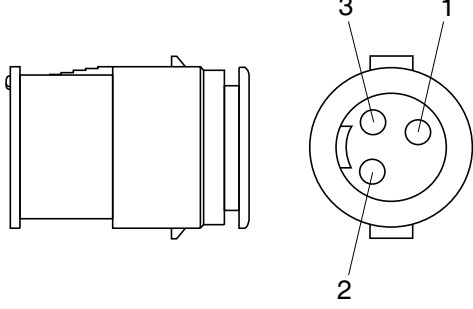
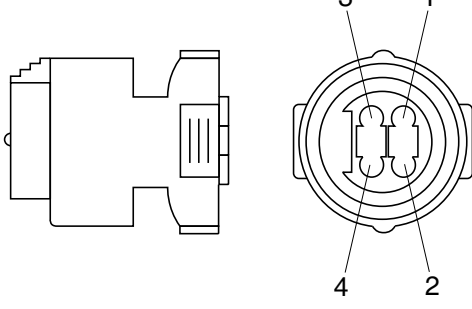
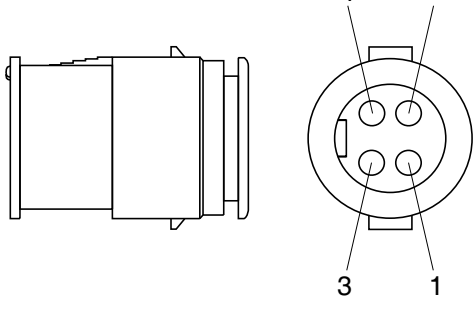
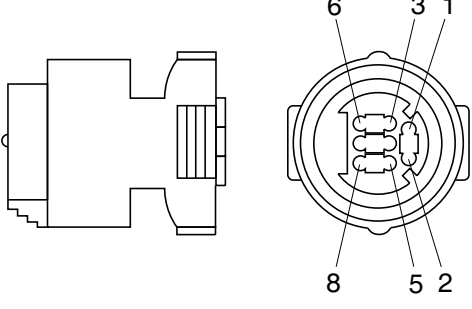
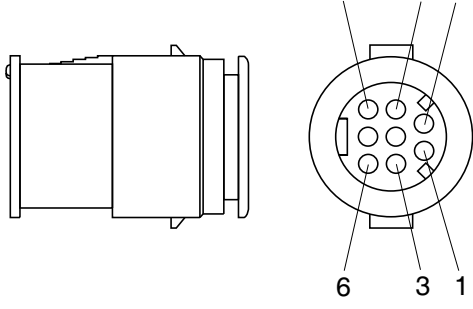
No. of pin	Receptacle connector (female)	Plug connector (male)
2	 <p style="text-align: center;">S816-002001</p>	 <p style="text-align: center;">S816-102001</p>
3	 <p style="text-align: center;">S816-003001</p>	 <p style="text-align: center;">S816-103001</p>
4	 <p style="text-align: center;">S816-004001</p>	 <p style="text-align: center;">S816-104001</p>
8	 <p style="text-align: center;">S816-008001</p>	 <p style="text-align: center;">S816-108001</p>

3) SWP TYPE CONNECTOR

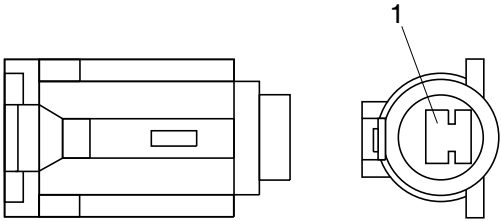
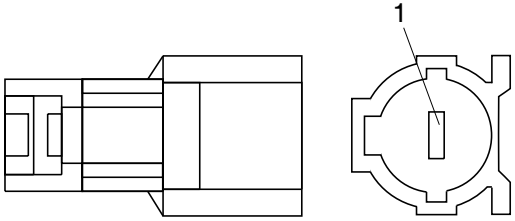
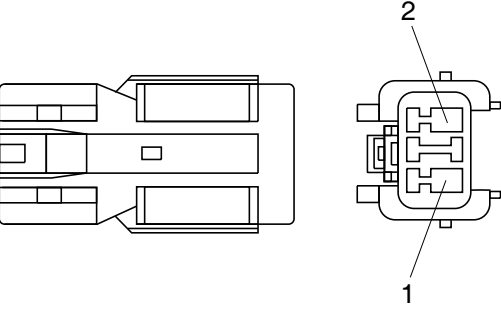
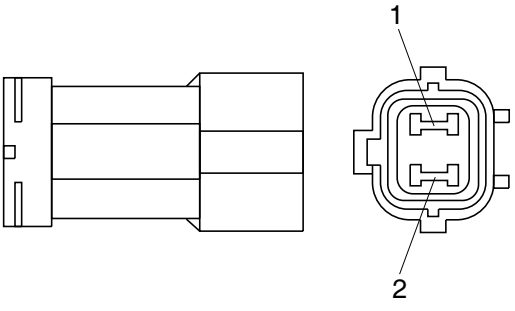
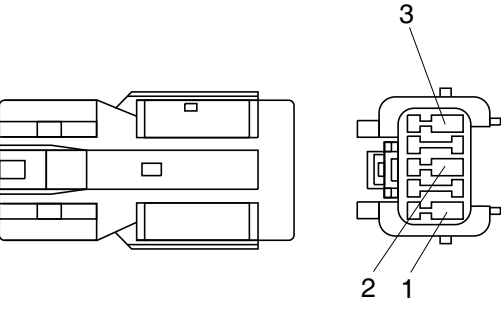
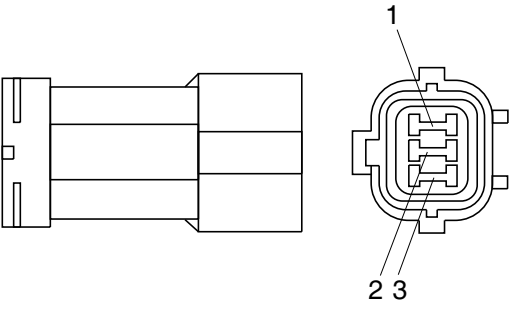
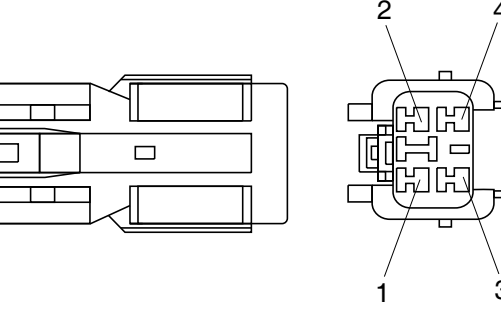
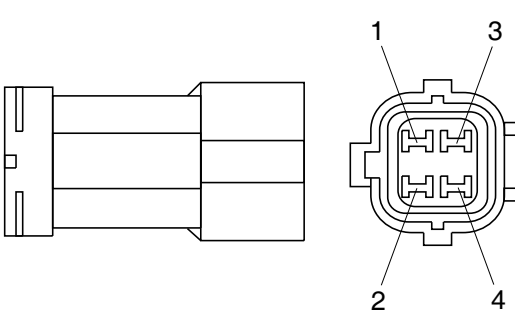
No. of pin	Receptacle connector (female)	Plug connector (male)
1	 <p data-bbox="687 680 836 707">S814-001000</p>	 <p data-bbox="1241 680 1390 707">S814-101000</p>
2	 <p data-bbox="687 1084 836 1111">S814-002000</p>	 <p data-bbox="1241 1084 1390 1111">S814-102000</p>
3	 <p data-bbox="687 1487 836 1514">S814-003000</p>	 <p data-bbox="1241 1487 1390 1514">S814-103000</p>
4	 <p data-bbox="687 1890 836 1917">S814-004000</p>	 <p data-bbox="1241 1890 1390 1917">S814-104000</p>

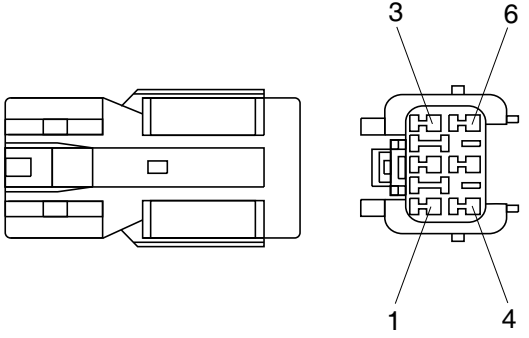
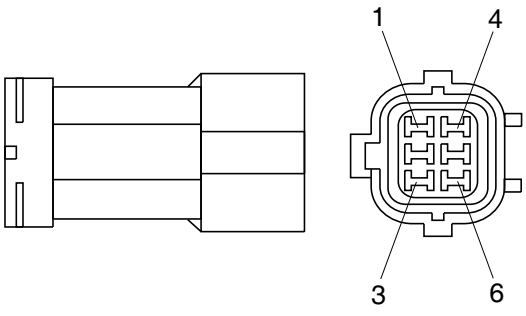
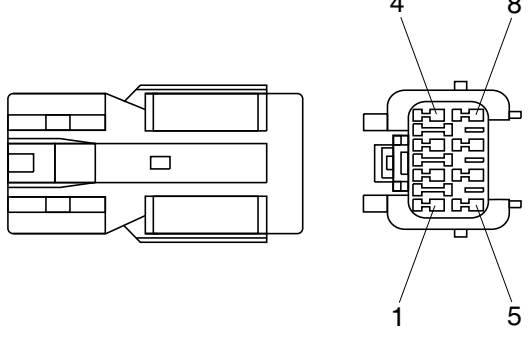
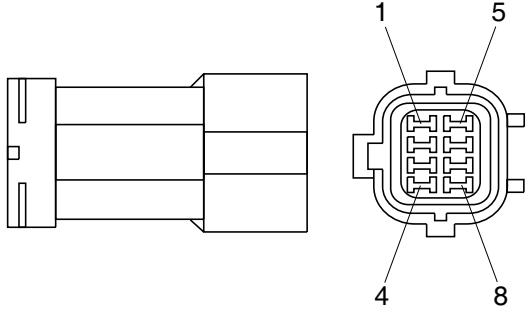
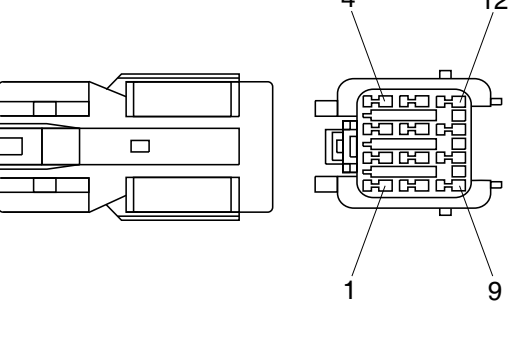
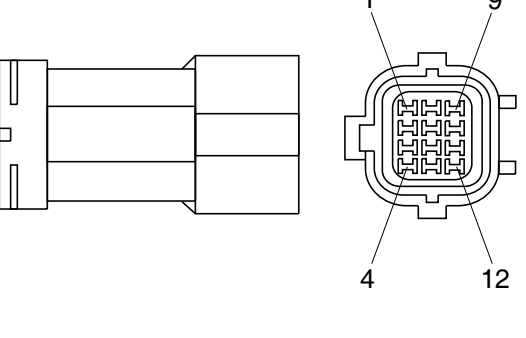
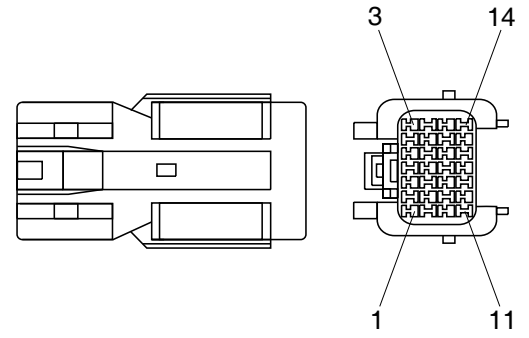
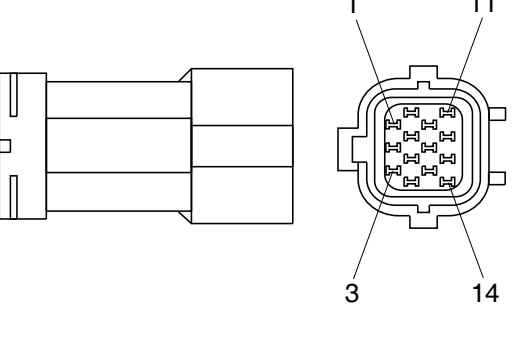
No. of pin	Receptacle connector (female)	Plug connector (male)
6	 <p data-bbox="686 638 837 672">S814-006000</p>	 <p data-bbox="1236 638 1388 672">S814-106000</p>
8	 <p data-bbox="686 1041 837 1075">S814-008000</p>	 <p data-bbox="1236 1041 1388 1075">S814-108000</p>
12	 <p data-bbox="686 1444 837 1478">S814-012000</p>	 <p data-bbox="1236 1444 1388 1478">S814-112000</p>
14	 <p data-bbox="686 1848 837 1881">S814-014000</p>	 <p data-bbox="1236 1848 1388 1881">S814-114000</p>

4) CN TYPE CONNECTOR

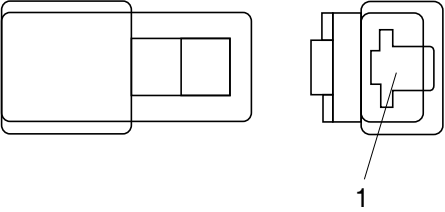
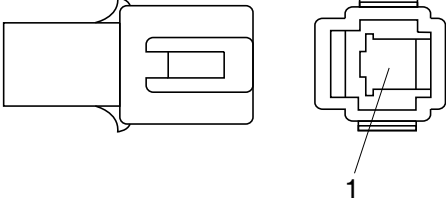
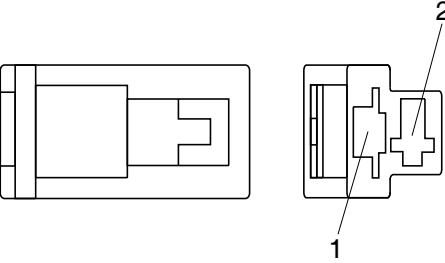
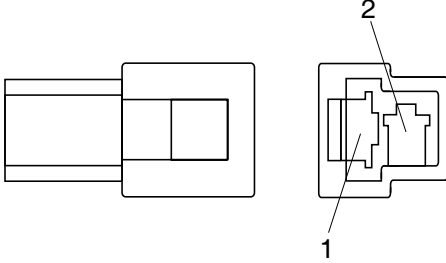
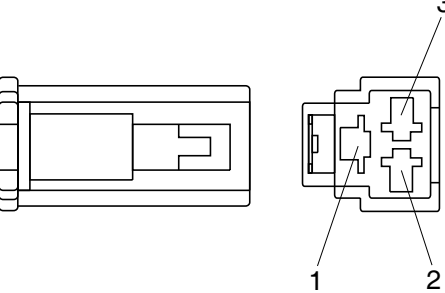
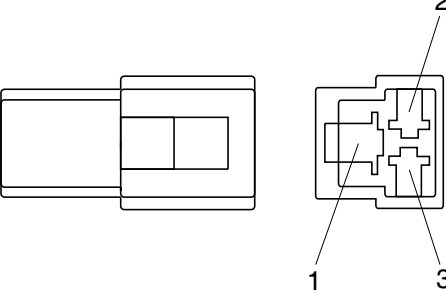
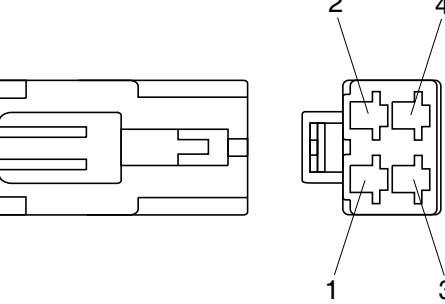
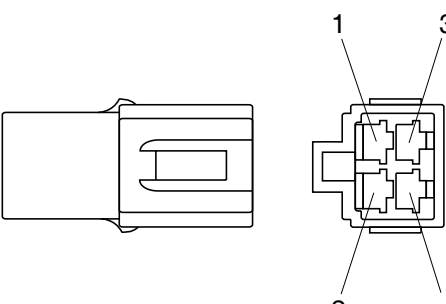
No. of pin	Receptacle connector (female)	Plug connector (male)
1	 <p data-bbox="687 680 836 707">S810-001202</p>	 <p data-bbox="1241 680 1390 707">S810-101202</p>
2	 <p data-bbox="687 1088 836 1115">S810-002202</p>	 <p data-bbox="1241 1088 1390 1115">S810-102202</p>
3	 <p data-bbox="687 1496 836 1523">S810-003202</p>	 <p data-bbox="1241 1496 1390 1523">S810-103202</p>
4	 <p data-bbox="687 1901 836 1928">S810-004202</p>	 <p data-bbox="1241 1901 1390 1928">S810-104202</p>

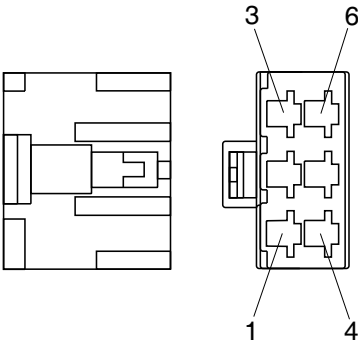
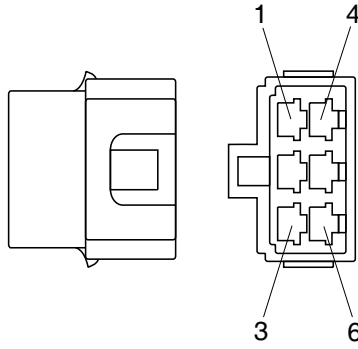
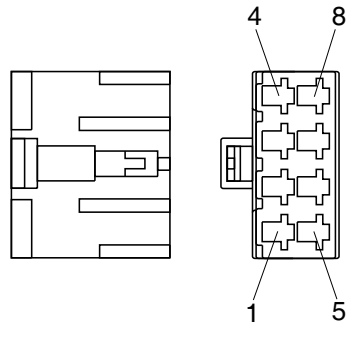
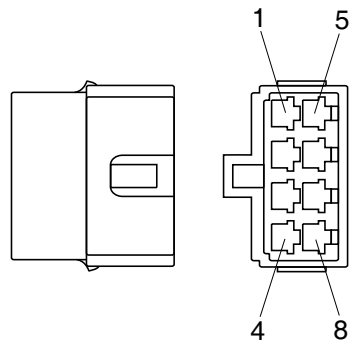
No. of pin	Receptacle connector (female)	Plug connector (male)
6	 <p data-bbox="686 638 837 672">S810-006202</p>	 <p data-bbox="1244 638 1396 672">S810-106202</p>
8	 <p data-bbox="686 1041 837 1075">S810-008202</p>	 <p data-bbox="1244 1041 1396 1075">S810-108202</p>

5) 375 FASTEN TYPE CONNECTOR

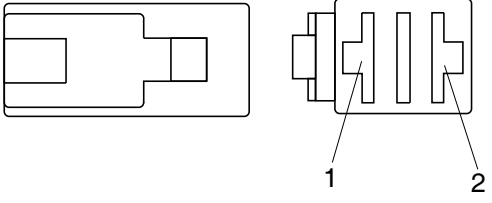
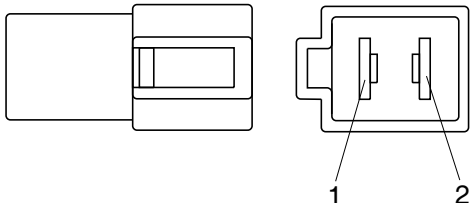
No. of pin	Receptacle connector (female)	Plug connector (male)
2	 <p style="text-align: center;">S810-002402</p>	 <p style="text-align: center;">S810-102402</p>

6) AMP ECONOSEAL CONNECTOR

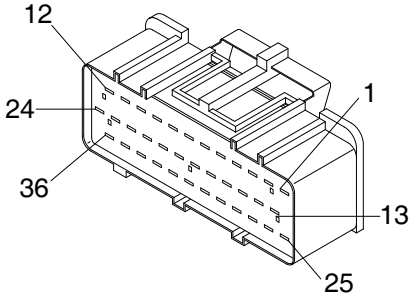
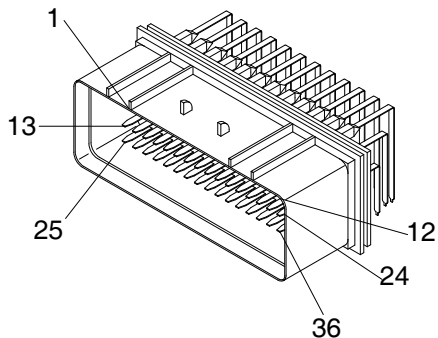
No. of pin	Receptacle connector (female)	Plug connector (male)
36	 <p style="text-align: center;">344111-1</p>	 <p style="text-align: center;">344108-1</p>

7) AMP TIMER CONNECTOR

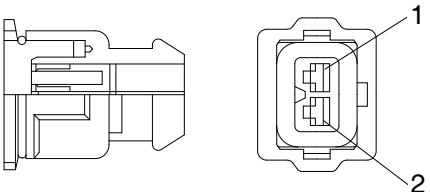
No. of pin	Receptacle connector (female)	Plug connector (male)
2	 <p style="text-align: center;">85202-1</p>	

8) AMP 040 MULTILOCK CONNECTOR

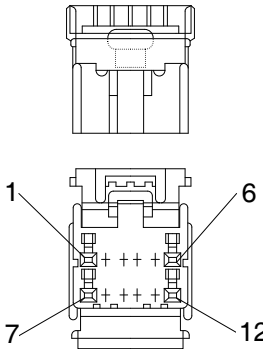
No. of pin	Receptacle connector (female)	Plug connector (male)
12	 <p style="text-align: right;">174045-2</p>	

9) AMP 070 MULTILOCK CONNECTOR

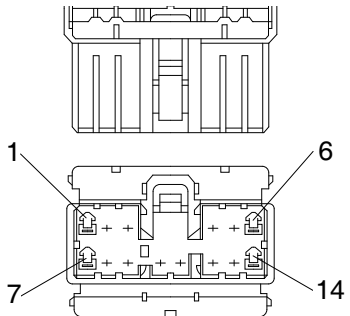
No. of pin	Receptacle connector (female)	Plug connector (male)
14	 <p style="text-align: right;">173852</p>	

10) AMP FASTIN - FASTON CONNECTOR

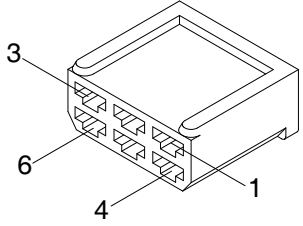
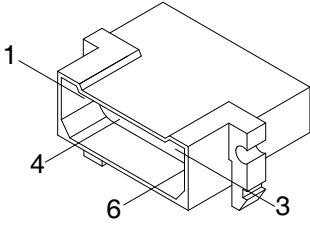
No. of pin	Receptacle connector (female)	Plug connector (male)
6	 <p style="text-align: right;">925276-0</p>	 <p style="text-align: right;">480003-9</p>

11) KET 090 CONNECTOR

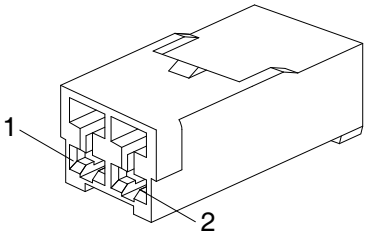
No. of pin	Receptacle connector (female)	Plug connector (male)
6	 <p style="text-align: right;">MG610070</p>	

12) KET 090 WP CONNECTORS

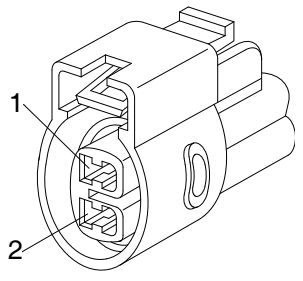
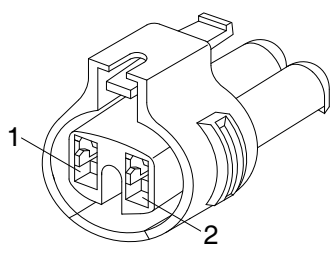
No. of pin	Receptacle connector (female)	Plug connector (male)
2	 <p style="text-align: right;">MG640605</p>	
2	 <p style="text-align: right;">MG640795</p>	

13) KET SDL CONNECTOR

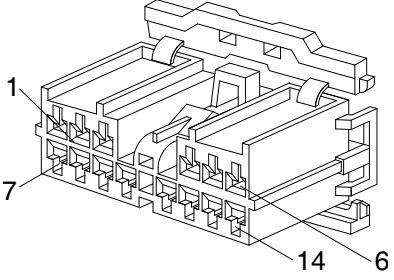
No. of pin	Receptacle connector (female)	Plug connector (male)
14	 <p data-bbox="715 680 837 707">MG610406</p>	

14) DEUTSCH DT CONNECTORS

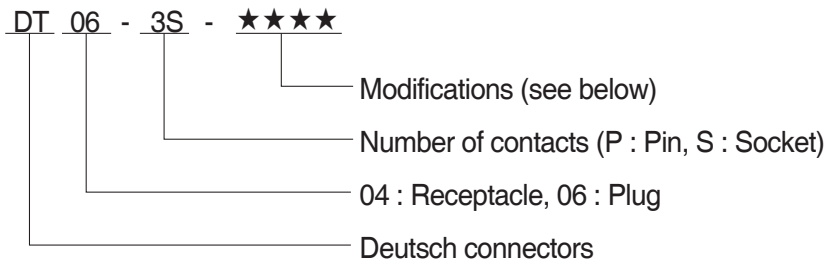

※ Modification

E003 : Standard end cap - gray

E004 : Color of connector to be black

E005 : Combination - E004 & E003

EP04 : End cap

EP06 : Combination P012 & EP04

P012 : Front seal enhancement - connectors color to black for 2, 3, 4 & 6pin

No. of pin	Receptacle connector (female)	Plug connector (male)
2	<p>DT06-2S</p>	<p>DT06-2P</p>
3	<p>DT06-3S</p>	<p>DT06-3P</p>
4	<p>DT06-4S</p>	<p>DT06-4P</p>

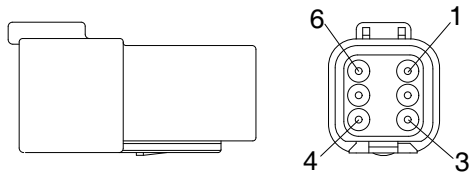
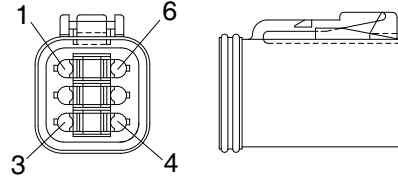
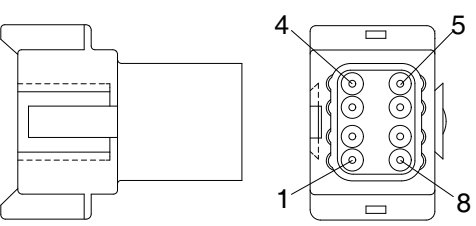
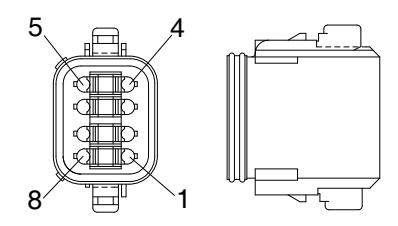
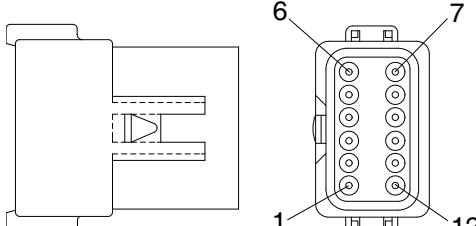
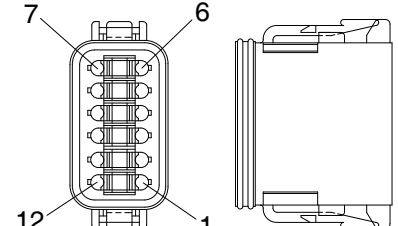
No. of pin	Receptacle connector (female)	Plug connector (male)
6	 <p style="text-align: right;">DT06-6S</p>	 <p style="text-align: right;">DT06-6P</p>
8	 <p style="text-align: right;">DT06-8S</p>	 <p style="text-align: right;">DT06-8P</p>
12	 <p style="text-align: right;">DT06-12S</p>	 <p style="text-align: right;">DT06-12P</p>

15) MOLEX 2CKTS CONNECTOR

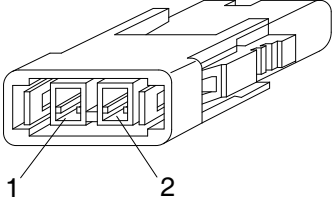
No. of pin	Receptacle connector (female)	Plug connector (male)
2	 <p style="text-align: right;">35215-0200</p>	

16) ITT SWF CONNECTOR

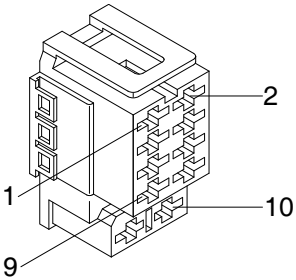
No. of pin	Receptacle connector (female)	Plug connector (male)
10	 <p style="text-align: right;">SWF593757</p>	

17) MWP NMWP CONNECTOR

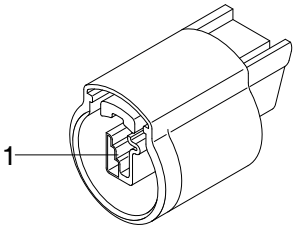
No. of pin	Receptacle connector (female)	Plug connector (male)
1	 <p style="text-align: right;">NMWP01F-B</p>	

GROUP 6 FAULT CODES

1. MACHINE FAULT CODE

Fault code		Description
HCESPN	FMI	
101	3	Hydraulic oil temperature sensor circuit - voltage above normal or shorted to high source (or open circuit)
	4	Hydraulic oil temperature sensor circuit - voltage below normal or shorted to low source
105	0	Working pressure sensor data above normal range (or open circuit)
	1	Working pressure sensor data below normal range
	2	Working pressure sensor data error
	4	Working pressure sensor circuit - voltage below normal, or shorted to low source
108	0	Travel oil pressure sensor data above normal range (or open circuit)
	1	Travel oil pressure sensor data below normal range
	2	Travel oil pressure sensor data error
	4	Travel oil pressure sensor circuit - voltage below normal or shorted to low source
122	0	Overload pressure sensor data above normal range (or open circuit)
	1	Overload pressure sensor data below normal range
	2	Overload pressure sensor data error
	3	Overload pressure sensor circuit - voltage below normal or shorted to low source
301	3	Fuel level sensor circuit - voltage above normal or shorted to high source (or open circuit)
	4	Fuel level sensor circuit - voltage below normal or shorted to low source
503	0	Brake pressure sensor data above normal range (or open circuit)
	1	Brake pressure sensor data below normal range
	2	Brake pressure sensor data error
	4	Brake pressure sensor data - voltage below normal or shorted to low source
505	0	Working brake pressure sensor data above normal range (or open circuit)
	1	Working brake pressure sensor data below normal range
	2	Working brake pressure sensor data error
	4	Working brake pressure sensor circuit - voltage below normal, or shorted to low source
530	0	Travel fwd pilot pressure sensor data above normal range (or open circuit)
	1	Travel fwd pilot pressure sensor data below normal range
	2	Travel fwd pilot pressure sensor data error
	4	Travel fwd pilot pressure sensor circuit - voltage below normal, or shorted to low source
	14	Travel fwd pilot pressure sensor circuit - special instructions
	16	Travel fwd pilot pressure sensor circuit - voltage valid but above normal operational range
701	4	Hour meter circuit - voltage below normal, or shorted to low source
705	0	MCU input voltage high
	1	MCU input voltage low
707	1	Alternator node I voltage low (or open circuit)
714	3	Acc. dial circuit - voltage above normal, or shorted to high source (or open circuit)
	4	Acc. dial circuit - voltage below normal, or shorted to low source

Fault code		Description
HCESPN	FMI	
840	2	Cluster communication data error
841	2	ECM communication data error
ISDP	2	Water in fuel warning
Lo bat	2	Low battery warning